



7450 Ethernet Service Switch
7750 Service Router
7950 Extensible Routing System
Virtualized Service Router
Releases up to 24.7.R2

Interface Configuration Advanced Configuration Guide for MD CLI

3HE 20791 AAAB TQZZA
Edition: 01
October 2024

Nokia is committed to diversity and inclusion. We are continuously reviewing our customer documentation and consulting with standards bodies to ensure that terminology is inclusive and aligned with the industry. Our future customer documentation will be updated accordingly.

This document includes Nokia proprietary and confidential information, which may not be distributed or disclosed to any third parties without the prior written consent of Nokia.

This document is intended for use by Nokia's customers ("You"/"Your") in connection with a product purchased or licensed from any company within Nokia Group of Companies. Use this document as agreed. You agree to notify Nokia of any errors you may find in this document; however, should you elect to use this document for any purpose(s) for which it is not intended, You understand and warrant that any determinations You may make or actions You may take will be based upon Your independent judgment and analysis of the content of this document.

Nokia reserves the right to make changes to this document without notice. At all times, the controlling version is the one available on Nokia's site.

No part of this document may be modified.

NO WARRANTY OF ANY KIND, EITHER EXPRESS OR IMPLIED, INCLUDING BUT NOT LIMITED TO ANY WARRANTY OF AVAILABILITY, ACCURACY, RELIABILITY, TITLE, NON-INFRINGEMENT, MERCHANTABILITY OR FITNESS FOR A PARTICULAR PURPOSE, IS MADE IN RELATION TO THE CONTENT OF THIS DOCUMENT. IN NO EVENT WILL NOKIA BE LIABLE FOR ANY DAMAGES, INCLUDING BUT NOT LIMITED TO SPECIAL, DIRECT, INDIRECT, INCIDENTAL OR CONSEQUENTIAL OR ANY LOSSES, SUCH AS BUT NOT LIMITED TO LOSS OF PROFIT, REVENUE, BUSINESS INTERRUPTION, BUSINESS OPPORTUNITY OR DATA THAT MAY ARISE FROM THE USE OF THIS DOCUMENT OR THE INFORMATION IN IT, EVEN IN THE CASE OF ERRORS IN OR OMISSIONS FROM THIS DOCUMENT OR ITS CONTENT.

Copyright and trademark: Nokia is a registered trademark of Nokia Corporation. Other product names mentioned in this document may be trademarks of their respective owners.

© 2024 Nokia.

Table of contents

List of figures.....	4
Preface.....	5
Port Cross-Connect (PXC).....	6

List of figures

Figure 1: Example topology.....	7
Figure 2: Non-redundant PXC.....	9
Figure 3: PXC redundant mode with LAG.....	12
Figure 4: AS mode with redundant FPE.....	24

Preface

About This Guide

Each Advanced Configuration Guide is organized alphabetically and provides feature and configuration explanations, CLI descriptions, and overall solutions. The Advanced Configuration Guide chapters are written for and based on several Releases, up to 24.7.R2. The Applicability section in each chapter specifies on which release the configuration is based.

The Advanced Configuration Guides supplement the user configuration guides listed in the 7450 ESS, 7750 SR, and 7950 XRS Guide to Documentation.

Audience

This manual is intended for network administrators who are responsible for configuring the routers. It is assumed that the network administrators have a detailed understanding of networking principles and configurations.

Port Cross-Connect (PXC)

This chapter provides information about Port Cross-Connect (PXC).

Topics in this chapter include:

- [Applicability](#)
- [Overview](#)
- [Configuration](#)
- [Conclusion](#)

Applicability

The chapter was initially written for SR OS Release 14.0.R5, but the MD-CLI in the current edition is based on SR OS Release 21.5.R1.

Overview

The Port Cross-Connect (PXC) feature allows for a port, or number of ports, to be logically looped to themselves. The purpose of looping a port in this manner is to provide an "anchor point" function, such that traffic may ingress the node through any interface/port and be redirected to that anchor point.

When traffic is passed through the egress data path of the PXC, it can be used for additional packet processing that cannot be supported on the ingress data path, such as the removal of an encapsulation header. When traffic is looped back to the ingress data path of the PXC, it is processed as if it were the conventional service termination point. This essentially decouples the Input/Output (I/O) port through which packets ingress the node from the I/O port that implements the service termination. This decoupling removes the previous constraint for pseudowire-port (pw-port) whereby the I/O port through which packets ingress and egress the node was bound and could not be changed during, for example, a reconvergence event.

PXC provides two modes of operation: Distributed Versatile Service Module (DVSM) mode and Application Specific (AS) mode.

- The DVSM mode provides functionality like that of the VSM2 card, enabling the user to create an internal loopback through the card. This allows for back-to-back configurations similar to a VLAN cross-connect.
- The AS mode creates a Forwarding Path Extension (FPE) context through which the system can automatically create cross-connects to simplify user provisioning. Use-case examples for AS mode include PW port for business VPN services, VXLAN termination on a non-system interface, ESM over Pseudowire, and GRE tunnel termination.

This chapter describes the generic principles of PXC, combined with examples of both DVSM mode and AS mode.

Example topology

The topology shown in [Figure 1: Example topology](#) is used within this chapter to illustrate the use of PXC. PE-2, PE-3, and PE-5 form part of Autonomous System 64496 and run IS-IS level 2 together with LDP for the MPLS control plane. PE-2, PE-3, and PE-5 also peer in IBGP for the VPN-IPv4 address family. Test ports are connected to all PEs (in the case of PE-2 and PE-3, via CE routers) for the purpose of validating IP connectivity.

Figure 1: Example topology

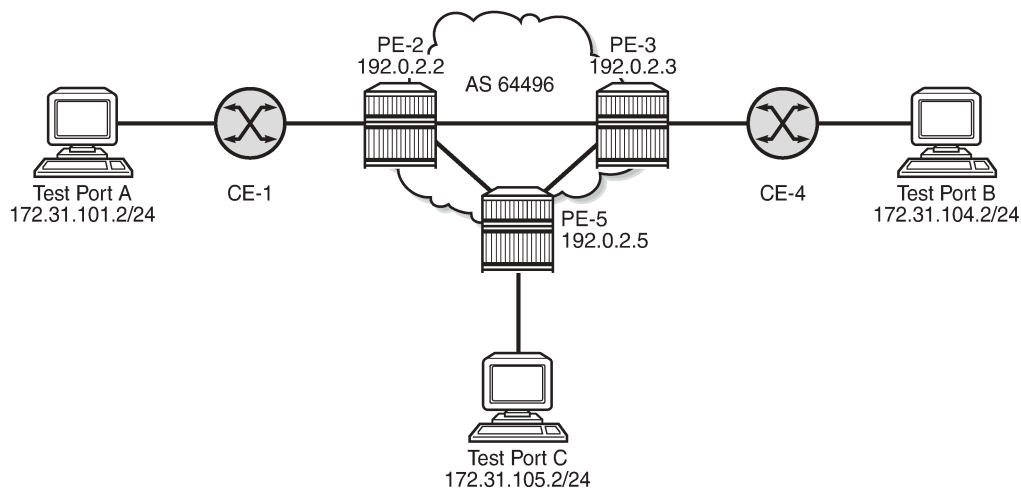

26223

PE-5 will host the PXC.

Configuration

PXC configuration

A PXC can consist of a single non-redundant port, or for redundancy and increased capacity, can consist of multiple ports that form member links of a Link Aggregation Group (LAG). Both options are described here.

Non-redundant PXC

The non-redundant PXC is created within the **port-xc** context and can be numbered from 1 to 64. The PXC sub-ports are identified by *a* and *b* suffixes of the parent PXC (in this example, pxc-1) and need to be enabled. The port assigned to the PXC also needs to be enabled. The configuration of PXC 1 on PE-5 is as follows:

```
# on PE-5:
configure {
  port-xc {
```

```

    pxc 1 {
        admin-state enable
        description "PXC non-redundant"
        port-id 1/2/1
    }
}
port pxc-1.a {
    admin-state enable
}
port pxc-1.b {
    admin-state enable
}
port 1/2/1 {
    admin-state enable
    ethernet {
        mode hybrid
        dot1x {
            tunneling true
        }
    }
}

```

There is no requirement for any kind of optical transceiver to be inserted in the port assigned to the PXC; it is only a logical loopback. When the port is assigned to the PXC, it cannot be used for any other purpose besides a PXC-based service assignment (for example, a regular SAP could not be configured on this port).

The PXC sub-ports are created in hybrid mode with an MTU of 8700 bytes, both of which are non-configurable. The 8700-byte MTU represents the default port MTU (in this example, 8704 bytes) minus four bytes to allow for an internal VLAN tag that is used to identify each back-to-back sub-port. Finally, the encapsulation is set to dot1q, which is the default for hybrid ports. The following command shows the details for both PXC sub-ports of PXC 1:

```

[/]
A:admin@PE-5# show port pxc 1
=====
Ports on Port Cross Connect 1
=====
Port      Admin Link Port   Cfg Oper LAG/ Port Port Port  C/QS/S/XFP/
Id        State State  State MTU MTU  Bndl Mode Encp Type  MDIMDX
-----
pxc-1.a   Up    Yes  Up    8700 8700  -  hybr dotq xgige
pxc-1.b   Up    Yes  Up    8700 8700  -  hybr dotq xgige
=====

```

Q-in-Q encapsulation is also supported. It is also possible to configure dot1q encapsulation on one PXC sub-port and Q-in-Q encapsulation on the opposing PXC sub-port if, for example, there is a requirement to expose more VLAN tags on one side of the loop than the other side of the loop.

The command in the following output can be used to verify the operational state of the PXC:

```

[/]
A:admin@PE-5# show port-xc pxc 1
=====
Port Cross-Connect Information
=====
PXC   Admin   Oper   Port   Description
Id    State  State  Id
-----
1     Up      Up     1/2/1  PXC non-redundant

```

Similarly, the operational state of each of the sub-ports can be verified as follows. The physical link is indicated as being present even though there is no transceiver installed in this port.

```
*A:PE-5# show port pxc-1.a
=====
Ethernet Interface
=====
Description      : Port cross-connect
Interface        : pxc-1.a           Oper Speed      : 10 Gbps
Link-level       : Ethernet          Config Speed    : N/A
Admin State      : up                Oper Duplex     : full
Oper State       : up
Config Duplex    : N/A
Physical Link  : Yes              MTU             : 8700
Single Fiber Mode : No               Min Frame Length : 64 Bytes
IfIndex          : 1090523137        Hold time up    : 0 seconds
Last State Change : 05/25/2021 10:24:01 Hold time down  : 0 seconds
Last Cleared Time : N/A
Phys State Chng Cnt: 0
---snip---
```

Figure 2: Non-redundant PXC shows a representation of the non-redundant PXC configuration. Both upstream and downstream traffic will pass twice through the FP data-path and port. For example, downstream traffic passes through the FP complex and PXC-1.b. The traffic is then looped back to PXC-1.a, and back into the FP complex. Similarly, upstream traffic passes through the FP complex to PXC-1.a. It is then looped back to PXC-1.b and back into the FP complex.

Figure 2: Non-redundant PXC

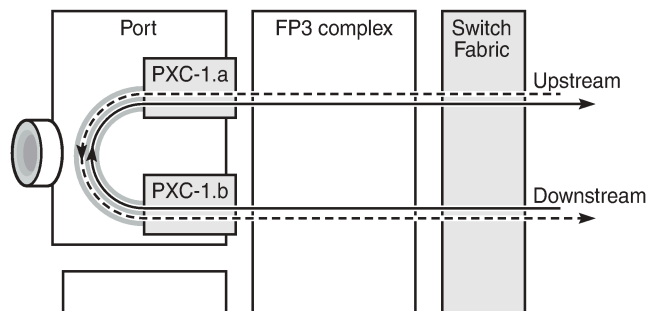

26224

When using a PXC, the physical port effectively simulates two (sub-)ports, which creates two egress traffic paths: one upstream and one downstream. When the receive side of the PXC port receives those paths, it needs to distinguish between them, and this is where the internal additional VLAN tag is used.

The difference between this PXC configuration and a conventional port not looped or configured as PXC is as follows. With a conventional port, ingress traffic passes through the port and ingress data-path of the FP complex only once, and egress traffic passes through the egress data-path of the FP complex and port only once.

Redundant PXC

For a redundant PXC, the fundamental building blocks are identical to those of the non-redundant PXC, but there are a few additional configuration steps required to construct the LAGs to which the redundant PXC ports belong.

The redundant PXC example consists of two ports: 1/2/2 and 1/2/3 in the following output. In this case, the redundant PXC ports belong to the same IMM, but different IMM can be used for increased redundancy. Two PXC are created and each one is assigned one of the redundant PXC ports. Both PXC are enabled, as well as their sub-ports and the associated physical ports. The configuration of PXC 2 and PXC 3 on PE-5 is as follows:

```
# on PE-5:
configure {
  port-xc {
    pxc 2 {
      admin-state enable
      description "PXC redundant"
      port-id 1/2/2
    }
    pxc 3 {
      admin-state enable
      description "PXC redundant"
      port-id 1/2/3
    }
  }
  port pxc-2.a {
    admin-state enable
  }
  port pxc-2.b {
    admin-state enable
  }
  port pxc-3.a {
    admin-state enable
  }
  port pxc-3.b {
    admin-state enable
  }
  port 1/2/2 {
    admin-state enable
    ethernet {
      mode hybrid
      dot1x {
        tunneling true
      }
    }
  }
  port 1/2/3 {
    admin-state enable
    ethernet {
      mode hybrid
      dot1x {
        tunneling true
      }
    }
  }
}
```

The details of the sub-ports of the PXC can be verified as follows:

```
[/]
```

```
A:admin@PE-5# show port pxc 2

=====
Ports on Port Cross Connect 2
=====
Port      Admin Link Port   Cfg  Oper LAG/ Port Port Port  C/QS/S/XFP/
Id        State  State State MTU  MTU  Bndl Mode Encp Type  MDIMDX
-----
pxc-2.a   Up     Yes  Up    8700 8700  - hybr dotq xgige
pxc-2.b   Up     Yes  Up    8700 8700  - hybr dotq xgige
=====
```

```
[/]
A:admin@PE-5# show port pxc 3

=====
Ports on Port Cross Connect 3
=====
Port      Admin Link Port   Cfg  Oper LAG/ Port Port Port  C/QS/S/XFP/
Id        State  State State MTU  MTU  Bndl Mode Encp Type  MDIMDX
-----
pxc-3.a   Up     Yes  Up    8700 8700  - hybr dotq xgige
pxc-3.b   Up     Yes  Up    8700 8700  - hybr dotq xgige
=====
```

The operational state of the PXC's can be verified as follows:

```
[/]
A:admin@PE-5# show port-xc pxc 2

=====
Port Cross-Connect Information
=====
PXC      Admin  Oper   Port   Description
Id       State State   Id
-----
2        Up     Up     1/2/2  PXC redundant
=====
```

```
[/]
A:admin@PE-5# show port-xc pxc 3

=====
Port Cross-Connect Information
=====
PXC      Admin  Oper   Port   Description
Id       State State   Id
-----
3        Up     Up     1/2/3  PXC redundant
=====
```

The PXC sub-ports are then associated with two LAGs to essentially form an internal back-to-back LAG. To do this, both sub-ports with the .a suffix belong to one LAG instance, and both sub-ports with the .b suffix belong to the other LAG instance. Like any other LAG member links, PXC sub-ports in a LAG must be configured with the same physical attributes, such as speed and duplex. Both LAG instances are configured with **mode hybrid** to match the mode of the physical ports. Setting the mode to **hybrid** automatically sets the **encap-type** to **dot1q**.

```
# on PE-5:
configure {
```

```

lag "lag-1" {
  admin-state enable
  mode hybrid
  max-ports 64
  port pxc-2.a {
  }
  port pxc-3.a {
  }
}
lag "lag-2" {
  admin-state enable
  mode hybrid
  max-ports 64
  port pxc-2.b {
  }
  port pxc-3.b {
  }
}
    
```

Figure 3: PXC redundant mode with LAG shows a representation of the redundant PXC with LAG. Both upstream and downstream traffic will pass twice through the FP data-path and port.

Figure 3: PXC redundant mode with LAG

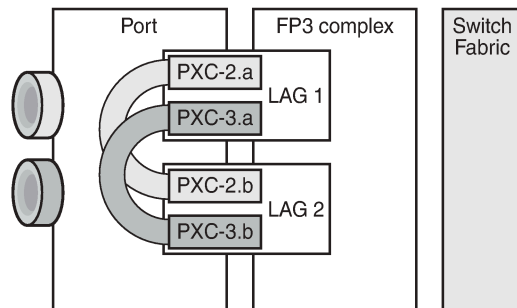

26225

When the LAGs are configured and the associated PXC sub-ports assigned as member links, the operational status can be verified. Note that at the LAG level, each of the configured LAG instances is not aware that it is internally connected to another LAG instance, even though the member sub-ports are logically looped. It would be possible, for example, to configure LAG 1 with **admin-state disable** and not affect the operational state of LAG 2. LACP is not supported for PXC LAG; however, it is possible to run the 802.3ah Ethernet in the First Mile (EFM) at PXC sub-port level, if required.

```

[/]
A:admin@PE-5# show lag "lag-1" detail

=====
LAG Details
=====
Description      : N/A
-----
Details
-----
Lag-id           : 1                Mode           : hybrid
Lag-name         : lag-1
Adm              : up                Opr            : up
Thres. Last Cleared : 05/25/2021 10:00:34  Thres. Exceeded Cnt : 0
Dynamic Cost     : false            Encap Type     : dot1q
    
```

```

Configured Address : 02:1f:ff:00:01:41   Lag-IfIndex       : 1342177281
Hardware Address   : 02:1f:ff:00:01:41   Adapt Qos (access) : distribute
Hold-time Down    : 0.0 sec              Port Type         : standard
Per-Link-Hash     : disabled
Include-Egr-Hash-Cfg: disabled
Per FP Ing Queuing : disabled           Per FP Egr Queuing  : disabled
Per FP SAP Instance : disabled
Access Bandwidth   : N/A                 Access Booking Factor: 100
Access Available BW : 0
Access Booked BW   : 0
LACP               : disabled
Standby Signaling  : lacp
Port hashing       : port-speed          Port weight speed   : 0 gbps
Ports Up           : 2
Weights Up         : 2                   Hash-Weights Up     : 20
Monitor oper group : N/A
Adaptive loadbal.  : disabled            Tolerance           : N/A
    
```

Port-id	Adm	Act/Stdby	Opr	Primary	Sub-group	Forced	Prio
pxc-2.a	up	active	up	yes	1	-	32768
pxc-3.a	up	active	up		1	-	32768

DVSM mode

DVSM mode enables the creation of a back-to-back cross-connect. This back-to-back connection can be network-to-network, access-to-access, or a combination such as network-to-access. To provide an example of using DVSM mode, PE-3 in [Figure 1: Example topology](#) functions as a Layer 2 backhaul device, and PE-5 housing the PXC functions as the Layer 3 service edge. A pseudowire is extended from PE-3 to PE-5, where it is terminated in a VPRN, providing point-to-point connectivity between CE-4 and PE-5.

VLAN 100 is extended from CE-4 to PE-3, where it is indexed into an Epipe service. The SAP is service-delimiting; therefore, the VLAN is removed before frames are encapsulated into the pseudowire. The Epipe then has a single non-redundant spoke-SDP to PE-5 with VC-ID 11. The service configuration on PE-3 is as follows:

```

# on PE-3:
configure {
  service {
    epipe "Epipe 11" {
      admin-state enable
      service-id 11
      customer "1"
      spoke-sdp 35:11 {
      }
      sap 1/1/3:100 {
      }
    }
    sdp 35 {
      admin-state enable
      delivery-type mpls
      ldp true
      far-end {
        ip-address 192.0.2.5
      }
    }
  }
}
    
```

At PE-5, the configuration of the corresponding end of the Epipe service is shown in the following output. This service consists of a single spoke-SDP toward PE-3 with VC-ID 11 to match the VC-ID advertised by PE-3, and a single SAP toward the PXC port. The syntax takes the form "pxc-n.l:vlan" where "n" is the PXC identifier, "l" is the sub-port letter (in this case .a), and "vlan" represents the VLAN identifier of the SAP.

As shown in the following output, the Epipe service uses PXC 1, which is the non-redundant PXC port. This is only an example; it could similarly use the redundant PXC port, in which case the SAP syntax would be the conventional LAG syntax (for example, lag-1:100, lag-2:100). Also note that although VLAN 100 is used both at PE-3's Epipe SAP and PE-5's Epipe PXC SAP, there is no correlation or dependence between the two. Both VLAN tags are service-delimiting and are subsequently stripped before the Ethernet frame is encapsulated into the pseudowire payload, so any valid VLAN value could be used at either point. The service configuration on PE-5 is as follows:

```
# on PE-5:
configure {
  service {
    epipe "Epipe 11" {
      admin-state enable
      service-id 11
      customer "1"
      spoke-sdp 53:11 {
      }
      sap pxc-1.a:100 {
      }
    }
    sdp 53 {
      admin-state enable
      delivery-type mpls
      ldp true
      far-end {
        ip-address 192.0.2.3
      }
    }
  }
}
```

The VPRN configuration at the corresponding side of the PXC port is shown in the following output. The VPRN has two interfaces: the first is toward a directly connected test port used to verify IP connectivity, and the second ("to-CE-4") is toward CE-4 and has a SAP with a PXC syntax. The PXC syntax represents the same PXC and VLAN identifiers as the preceding Epipe configuration, but the PXC sub-port is .b, to represent the "other side" of the PXC logical loopback. Therefore, the VLAN values must match to create the back-to-back connection. A BGP session is configured between PE-5 and CE-4 for route exchange. VPRN 10 is configured as follows:

```
# on PE-5:
configure {
  service {
    vprn "VPRN 10" {
      description "VPRN 10 using PXC DVSM"
      admin-state enable
      service-id 10
      customer "1"
      autonomous-system 64496
      bgp-ipvprn {
        mpls {
          admin-state enable
          route-distinguisher "64496:10"
          vrf-import {
            policy ["vrf10-import"]
          }
          vrf-export {

```

```
        policy ["vrf10-export"]
        }
        auto-bind-tunnel {
            resolution any
        }
    }
}
bgp {
    ebgp-default-reject-policy {
        import false
    }
    group "EBGP" {
        peer-as 64511
        family {
            ipv4 true
        }
    }
    neighbor "192.168.45.1" {
        split-horizon true
        group "EBGP"
        as-override true
        export {
            policy ["vrf-ebgp-export"]
        }
    }
}
interface "Test-Port-C" {
    ipv4 {
        primary {
            address 172.31.105.1
            prefix-length 24
        }
    }
    sap 1/1/3:100 {
    }
}
interface "to-CE-4" {
    ipv4 {
        primary {
            address 192.168.45.2
            prefix-length 30
        }
    }
    sap pxc-1.b:100 {
    }
}
```

PXC port dimensioning

When the VPRN service at PE-5 is in **admin-state enable**, the EBGP session to CE-4 is established. The relevant routes are exchanged between CE-4 and PE-5 and traffic can be exchanged between test ports B (connected to CE-4) and C (connected to PE-5). Initially, traffic is sent from test port B toward port C at a rate of 100 packets/s. Traffic is intentionally sent in only one direction (in this example) to emphasize a point regarding PXC port dimensioning and capacity planning, as follows.

The PXC in use by the Epipe/VPRN service is PXC 1, which uses physical port 1/2/1. The following output—in classic CLI—shows a snapshot of a monitor command against the physical port. Although traffic is only being sent in a single direction (test port B behind CE-4 toward test port C connected to PE-5), the

input/output rate of packets per second is the same at 100 packets/s. This is because the physical port consists of two PXC sub-ports that are looped.

```
*A:PE-5# monitor port 1/2/1 rate interval 3

=====
Monitor statistics for Port 1/2/1
=====
-----
Input                               Output
-----
---snip---
-----
At time t = 3 sec (Mode: Rate)
-----
Octets                               51600                               51600
Packets                              100                                100
Errors                                0                                  0
Bits                                 412800                             412800
Utilization (% of port capacity)    ~0.00                              ~0.00
```

In this example, traffic is output from pxc-1.a when traffic is sent from the Epipe SAP into the PXC port, and traffic is input at pxc-1.b when traffic is received by the VPRN SAP from the PXC port. Because both upstream/ingress traffic and downstream/egress traffic will be seen as output packets using the available capacity of the physical port, this needs to be considered when capacity is being planned.

QoS continuity

The application of ingress/egress SAP QoS policies is fundamentally the same for a PXC-based SAP as it is for a conventional SAP. However, there is a difference with regard to how ingress Forwarding Class (FC) mappings are maintained throughout the PXC in DVSM mode. On a conventional SAP, ingress packets are classified and mapped to an FC. That FC mapping is maintained (as part of the fabric header) when the packet transits through the system and is ultimately used to define the egress queue and egress marking, such as MPLS EXP bits or dot1p bits.

However, the PXC sub-ports are subtly different. Consider SAP ingress traffic entering the VPRN at PE-5 from the locally connected test port C destined toward test port B at CE-4. At the ingress to PE-5, this traffic is mapped to FC Expedited Forwarding (EF) and forwarded into the PXC port through SAP pxc-1.b:100. When the traffic is forwarded out of the (PXC) SAP, the fabric header is removed as if it were a conventional SAP, and therefore, the information conveying the FC mapping is lost. When the traffic arrives at the opposing PXC sub-port SAP (in this case, pxc-1.a:100), a further FC classification is undertaken, and without some non-default configuration, traffic will be classified as FC Best Effort (BE). Therefore, it is a requirement to use non-default ingress/egress QoS policies through the PXC port in order to maintain FC continuity. A relatively simple way to do to this is through the use of dot1p markings.

To illustrate how this FC continuity is achieved, and in general how QoS is applied to PXC ports, an example of the relevant policies applied to PE-5's egress traffic toward CE-4 is used.

The first of the following outputs provides an example of the SAP-egress QoS policy applied at the VPRN PXC SAP (pxc-1.b:100). There are three classes in use: BE, Assured-Forwarding (AF), and EF. These FCs are remapped to queues 1, 2, and 3, respectively, and each queue is mapped to a parent H-QoS scheduler. Because the FCs must be maintained through the PXC loop, dot1p markings are used to distinguish between them. FC EF uses dot1p 5, FC AF uses dot1p 3, and FC BE uses dot1p 1. The SAP egress QoS policy is configured on PE-5 as follows:

```
# on PE-5:
configure {
```



```
qos {
  sap-egress "SAP egress 2" {
    policy-id 2
    queue 1 {
      scheduler-parent {
        scheduler-name "aggregate-rate"
        level 2
        weight 10
      }
    }
    queue 2 {
      queue-type best-effort
      rate {
        pir 5000
        cir max
      }
      scheduler-parent {
        scheduler-name "aggregate-rate"
        level 2
        weight 40
        cir-level 2
      }
    }
    queue 3 {
      queue-type expedited
      rate {
        pir 2000
        cir 2000
      }
      scheduler-parent {
        scheduler-name "aggregate-rate"
        cir-level 3
      }
    }
  }
  fc be {
    queue 1
    dot1p {
      in-profile 1
      out-profile 1
      exceed-profile 1
    }
  }
  fc af {
    queue 2
    dot1p {
      in-profile 3
      out-profile 3
      exceed-profile 3
    }
  }
  fc ef {
    queue 3
    dot1p {
      in-profile 5
      out-profile 5
      exceed-profile 5
    }
  }
}
```

The configuration of the Tier 1 scheduler "aggregate-rate" referenced by the child queues in the preceding SAP-egress QoS policy is shown in the following output. The scheduler in turn references a **port-scheduler-policy** using the command **port-parent**. Parenting to a port-scheduler is optional, but allows

for inclusion of Preamble and Inter-Frame Gap (IFG) in the QoS scheduling algorithm, which is otherwise not included by a conventional H-QoS scheduler. The **port-scheduler-policy** "port-scheduler" is not referenced directly by the Tier 1 scheduler, but rather the port-scheduler is inherited by any child queues on the port to which the port-scheduler is applied. In this case, the **port-scheduler-policy** "port-scheduler" is applied to the PXC sub-port pxc-1.b as follows:

```
# on PE-5:
configure {
  qos {
    scheduler-policy "egress-hqos-scheduler" {
      tier 1 {
        scheduler "aggregate-rate" {
          rate {
            pir 1
          }
          port-parent {
          }
        }
      }
    }
    port-scheduler-policy "port-scheduler" {
    }
  }
  port pxc-1.b {
    admin-state enable
    ethernet {
      egress {
        port-scheduler-policy {
          policy-name "port-scheduler"
        }
      }
    }
  }
}
```

Finally, the SAP-egress QoS policy is applied to the PXC sub-port SAP within the VPRN interface context. The H-QoS scheduler is also attached and an override of the rate configured. In summary, the SAP-egress QoS policy configuration looks exactly like that used on a conventional SAP, other than the dot1p markings used for FC continuity, which may not always be used or required.

```
# on PE-5:
configure {
  service {
    vprn "VPRN 10" {
      interface "to-CE-4" {
        admin-state disable
        ipv4 {
          primary {
            address 192.168.45.2
            prefix-length 30
          }
        }
      }
      sap pxc-1.b:100 {
        admin-state disable
        egress {
          qos {
            sap-egress {
              policy-name "SAP egress 2"
            }
            scheduler-policy {
              policy-name "egress-hqos-scheduler"
              overrides {
                scheduler "aggregate-rate" {

```



```

spoke-sdp 53:11 {
}
sap pxc-1.a:100 {
  ingress {
    qos {
      sap-ingress {
        policy-name "SAP ingress 11"
      }
    }
  }
}

```

The preceding configuration shows the required QoS policies for downstream traffic (VPRN egress to Epipe ingress). Corresponding QoS policies must also be configured for upstream traffic (Epipe egress to VPRN ingress). For brevity, they are not shown here.

AS mode

AS mode creates an FPE context that is used to provide information to the system about which PXC ports or LAGs are paired, so that the configuration process can be simplified by automatic provisioning of cross-connects. To illustrate the use of AS mode, the redundant PXC (formed of LAG 1 and 2) configured earlier in this chapter is used. However, redundancy is not a requirement. Non-redundant PXC ports can also be used with AS mode.

For AS mode, a similar setup to the DVSM example is used, with Epipe termination into a VPRN. This provides a generic view of the applicability of AS mode, but also allows a direct comparison between the DVSM and AS mode approaches. Again, PE-3 in [Figure 1: Example topology](#) functions as a Layer 2 backhaul device and PE-5 hosts the PXC functions as the Layer 3 service edge. A pseudowire is extended from PE-3 to PE-5 where it will be terminated in a VPRN, providing point-to-point connectivity between CE-4 and PE-5.

The following output illustrates the configuration of the Epipe service at PE-3. CE-4 uses Q-in-Q encapsulation on the PE-CE link to PE-3 with SVLAN tag 100 and CVLAN tag 1024. At PE-3, it is indexed into an Epipe service using a q.* SAP to make the CVLAN tag transparent (part of the payload). As the spoke-SDP toward PE-5 is also configured with **force-vc-forwarding vlan**, both SVLAN and CVLAN tags will be encapsulated in the pseudowire payload.

```

# on PE-3:
configure {
  service {
    epipe "Epipe 13" {
      admin-state enable
      service-id 13
      customer "1"
      spoke-sdp 35:13 {
        force-vc-forwarding vlan
      }
      sap 1/1/3:100.* {      # SAP to VPRN 12 on CE-4
      }
    }
  }
}

```

As in the previous configuration example, LAG 1 and LAG 2 are used for PXC redundancy. LAG 1 has the PXC sub-ports pxc-2.a and pxc-3.a as member links, while LAG 2 has the PXC sub-ports pxc-2.b and pxc-3.b as member links. For AS mode, the next requirement is to configure the FPE construct and assign the paired LAG instances to that FPE. When entering the **fwd-path-ext** context, the **sdp-id-range** must be configured before any **fpe** instances can be created. The **sdp-id-range** allocates a block of SDP identifiers

to be used for the automatic cross-connects between service applications and the FPE. Up to 128 SDP identifiers can be allocated in the range 1 to 17407.

After the **sdp-id-range** is configured, the **fpe** instance is created and the user enters the **fpe** context. The **path** command is used to assign redundant or non-redundant PXC objects to the FPE. In the case of a non-redundant FPE, the **path** command would refer to a **pxc** instance. In the case of a redundant FPE, the **path** syntax requires that each of the paired LAG instances is assigned to cross-connect "a" or cross-connect "b".

Each FPE has two fundamental components, known as the transit side and the terminating side. The transit side is the side where additional traffic preprocessing is carried out, such as header removal or manipulation. It can be considered as the side closest to the network. The terminating side is the side where the preprocessed traffic is terminated in a service. When an FPE is used, the system automatically assigns cross-connect "a" to the transit side, and cross-connect "b" to the terminating side.

In the following example, the command **path>xc-lag-a "lag-1"** assigns LAG 1 to cross-connect "a" and the command **path>xc-lag-b "lag-2"** assigns LAG 2 to cross-connect "b". This means that LAG 1 is the transit side while LAG 2 is the terminating side.

The application of the FPE also needs to be configured. In this example, **pw-port true** is configured to allow for support of pseudowire-SAP (including Enhanced Subscriber Management (ESM) over pseudowire). The other available options (for example, **vlan-termination**) are beyond the scope of this chapter.

```
# on PE-5:
configure {
  fwd-path-ext {
    sdp-id-range {
      start 17280
      end 17407
    }
  }
  fpe 1 {
    path {
      xc-lag-a "lag-1"
      xc-lag-b "lag-2"
    }
    application {
      pw-port true
    }
  }
}
```

After the LAG instance is assigned to the FPE, it can no longer be used for other general purposes, such as IP interfaces and/or SAPs. Any attempt to do so is blocked in MD-CLI. The operational state of the FPE can be verified as shown in the following output. It is also useful to be able to identify the services and pw-ports that are mapped to an FPE. This can be obtained using the **show fwd-path-ext fpe <number> associations** command.

```
[/]
A:admin@PE-5# show fwd-path-ext fpe 1

=====
FPE Id: 1
=====
Description      : (Not Specified)
Path             : lag-1, lag-2
Pw Port          : Enabled           Oper    : up
Sub Mgmt Extension : Disabled       Oper    : N/A
Vxlan Termination : Disabled       Oper    : down
Segment-Routing V6 : Disabled
```

The next step is to configure a pseudowire-port (pw-port) that will be used for terminating services. The creation of the **pw-port** creates a new context in which the only required configuration is to define the encapsulation type as dot1q or qinq. In this instance, the **pw-port** will support **encap-type qinq**.

```
# on PE-5:
configure {
  pw-port 1 {
    encap-type qinq
  }
}
```

The operational state of the pw-port is captured as a reference at this point, so that a comparison can be made later in the configuration process.

```
[/]
A:admin@PE-5# show pw-port 1

=====
PW Port Information
=====
PW Port   Encap          SDP:VC-Id      IfIndex
-----
1         qinq          N/A            1526726657
=====
```

At PE-5, the requirement now is to link the spoke-SDP from PE-3 to the configured pw-port (pw-port 1) via the FPE. To do this, an Epipe service must be used that is configured for multi-segment pseudowire working, configured with the option **vc-switching true**. The Epipe service consists of a single spoke-SDP toward PE-3 with a VC-ID matching that signaled by PE-3 (VC-ID 13). The pw-port 1 refers to **fpe-id 1** in "Epipe 13". This command essentially creates an internal cross-connect between the Epipe service and the pw-port via the configured FPE object. The configuration is as follows:

```
# on PE-5:
configure {
  pw-port 1 {
    encap-type qinq
    epipe "Epipe 13" {
      fpe-id 1
    }
  }
  service {
    epipe "Epipe 13" {
      admin-state enable
      service-id 13
      customer "1"
      vc-switching true
      spoke-sdp 53:13 {
      }
    }
  }
}
```

The following output shows the SDPs belonging to the preceding vc-switched Epipe service configured. The first SDP with identifier 53:13 is the pseudowire toward PE-3 with VC-ID 13. The second SDP has identifier 17280:1 allocated from the preconfigured **sdp-id-range**, and has a type of Fpe. In the configuration of **fpe 1**, the **path** command assigned LAG 1 to cross-connect "a" (**xc-lag-a**) and LAG 2 to cross-connect "b" (**xc-lag-b**). Also, cross-connect "b" is always automatically assigned to the terminate side of the FPE. Therefore, the Far End address is shown as fpe_1.b, in order to terminate the service.

```
[/]
A:admin@PE-5# show service id 13 sdp
```

```

=====
Services: Service Destination Points
=====
SdpId          Type      Far End addr  Adm   Opr      I.Lbl      E.Lbl
-----
53:13         Spok     192.0.2.3    Up    Up       524279     524283
17280:1       Fpe     fpe_1.b      Up    Up       524281     524280
-----
Number of SDPs : 2
=====

```

With the vc-switching Epipe service configured and operational, the state of the pw-port can again be shown in the following output. Before the configuration of the vc-switching Epipe, the pw-port had no SDP identifier or VC-ID. Now both entries exist; automatically created by the system when **pw-port 1>epipe "Epipe 13">fpe-id 1** was configured. The SDP identifier of 17281 is allocated from the preconfigured **sdp-id-range**.

```

[/]
A:admin@PE-5# show pw-port 1

=====
PW Port Information
=====
PW Port  Encap      SDP:VC-Id      IfIndex
-----
1         qinq       17281:100001   1526726657
=====

```

The output for SDP 17281 shows that the Far End is fpe_1.a (transit), the Delivery (Del) is MPLS, the LSP type is FPE (F), and that no signaling (Sig) is used for this internal SDP, as follows:

```

[/]
A:admin@PE-5# show service sdp 17281

=====
Service Destination Point (Sdp Id : 17281)
=====
SdpId  AdmMTU  OprMTU  Far End      Adm  Opr      Del   LSP  Sig
-----
17281  0       8678   fpe_1.a      Up   Up       MPLS  F    None
=====

```

In SR OS, the combination of SDP ID and VC-ID is always associated with a service. When using AS mode, the system automatically creates an internal VPLS service with ID 2147383649 and a name of `_tmns_InternalVplsService`. This VPLS includes all internal SDPs dynamically created for binding pw-ports to the transit side of the corresponding FPE. The VPLS is an internal construct that does not affect forwarding.

Figure 4: AS mode with redundant FPE shows the components of the FPE from vc-switching Epipe to pw-port.

Figure 4: AS mode with redundant FPE

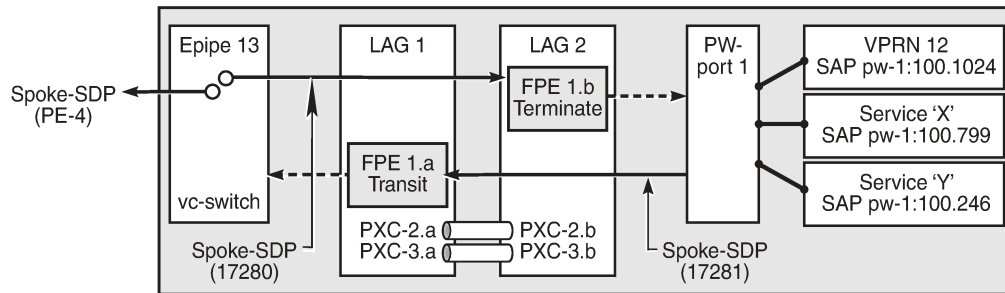

26266

Next, bind the VPRN service to the pw-port with the relevant VLAN delimiters. CE-4 is using SVLAN tag 100 and CVLAN tag 1024 and both VLANs are encapsulated inside the pseudowire as payload. The following VPRN configuration has two interfaces: the first is toward a directly connected test port used to verify IP connectivity, and the second is toward CE-4 and has a SAP with a pw-port syntax. The SAP pw-1:100.1024 represents pw-port 1 with Q-in-Q encapsulation using SVLAN tag 100 and CVLAN tag 1024 as service delimiters. A BGP session is configured between PE-5 and CE-4 for route exchange. The remainder of the VPRN parameters are generic and are not explained here.

```
# on PE-5:
configure {
  service {
    vprn "VPRN 12 using PXC AS" {
      admin-state enable
      service-id 12
      customer "1"
      autonomous-system 64496
      bgp-ipvpn {
        mpls {
          admin-state enable
          route-distinguisher "64496:12"
          vrf-target {
            community "target:64496:12"
          }
          auto-bind-tunnel {
            resolution any
          }
        }
      }
    }
  }
  bgp {
    group "EBGP" {
      peer-as 64511
      family {
        ipv4 true
      }
    }
    neighbor "192.168.45.1" {
      split-horizon true
      group "EBGP"
      as-override true
      ebgp-default-reject-policy {
        import false
      }
      export {
        policy ["vrf-ebgp-export"]
      }
    }
  }
}
```



```

    }
  }
  interface "Test-Port-C" {
    ipv4 {
      primary {
        address 172.31.105.1
        prefix-length 24
      }
    }
    sap 1/1/3:100 {
    }
  }
  interface "to-CE-4" {
    ipv4 {
      primary {
        address 192.168.45.2
        prefix-length 30
      }
    }
    sap pw-1:100.1024 {
    }
  }
}

```

FPE port dimensioning

After the VPRN service at PE-5 is configured with **admin-state enable**, the EBGP session to CE-4 is established. The relevant routes are exchanged between CE-4 and PE-5 and traffic can be exchanged between test ports B (behind CE-4) and C (connected to PE-5). Initially, traffic is sent unidirectionally from test port C (connected to PE-5) toward port B (connected to CE-4) at a rate of 100 packets/s. To provide a level of entropy for the generated traffic, 100 destination IP addresses are used in the range 172.31.104.2 through 172.31.104.101, and 100 source IP addresses are used in the range 172.31.105.2 through 172.31.105.101.

The following output—in classic CLI—shows a snapshot of a monitor command against LAG 2 (xc-lag-b, or terminating side) incorporating both physical ports. First, note that the input and output rate of packets per second are equal at 100 packets/s, which is not intuitive for a unidirectional traffic flow. This is because the LAG statistics are essentially a copy of the physical port statistics and the physical port consists of two PXC sub-ports that are looped. Logically, this unidirectional traffic flow is forwarded in a single upstream direction from pxc-2.a/pxc-3.a to pxc-2.b/pxc-3.b. Physically, the unidirectional traffic is transmitted by ports 1/2/2 and 1/2/3, then received by the same ports through the loop. Second, note that traffic is load-balanced over both member links (PXC sub-ports) of the LAG. This is because conventional LAG load-balancing mechanisms are used for the FPE LAG, which in the case of a VPRN SAP-to-network relies on source/destination IP address (with optional Layer 4, which is not currently configured).

```
*A:PE-5# monitor lag 2 rate interval 3
```

```
=====
Monitor statistics for LAG ID 2
=====
```

Port-id	Input packets Input bytes Input errors [Input util %]	Output packets Output bytes Output errors [Output util %]
-----snip-----		

```
At time t = 9 sec (Mode: Rate)
```

```
-----
1/2/2!      41                                41

```

	22041		22041	
1/2/3!	0	0.00	0	0.00
	59		59	
	32159		32159	
	0	0.00	0	0.00

Totals	100		100	
	54200		54200	
	0	0.00	0	0.00

! indicates that the port is assigned to a port-xc.

Traffic is then generated unidirectionally upstream from test port B (connected to CE-4) toward port C (connected to PE-5) at a rate of 100 packets/s. Again, to provide a level of entropy for the generated traffic, 100 destination IP addresses are used in the range 172.31.105.2 through 172.31.105.101, and 100 source IP addresses are used in the range 172.31.104.2 through 172.31.104.101. The input/output rates of packets per second are the same, as previously explained. Again, traffic is load-balanced over both member links (PXC sub-ports). This is because hashing of traffic through a vc-switched Epipe service uses source/destination IP information (and optional Layer 4 information, which is not currently configured).

```
*A:PE-5# monitor lag 2 rate interval 3
```

```
=====
```

```
Monitor statistics for LAG ID 2
```

```
=====
```

Port-id	Input packets		Output packets	
	Input bytes		Output bytes	
	Input errors [Input util %]		Output errors [Output util %]	

---snip---				

At time t = 9 sec (Mode: Rate)				

1/2/2!	44		44	
	23848		23848	
	0	0.00	0	0.00
1/2/3!	56		56	
	30352		30352	
	0	0.00	0	0.00

Totals	100		100	
	54200		54200	
	0	0.00	0	0.00

! indicates that the port is assigned to a port-xc.

QoS continuity

When using AS mode, the FPE construct creates internal cross-connects between the vc-switching Epipe and the pw-port. These internal cross-connects function as MPLS tunnels that transit through internal network interfaces on the PXC sub-ports. The internal network interfaces use the default network policy 1 for egress marking and ingress classification/FC mapping. Like all default QoS policies, this network policy cannot be modified (or deleted). Also, it is not possible to use a non-default network policy, because there is no router interface to which the non-default policy can be attached.

The internal cross-connects also use the default network-queue policy named "default". While this policy also cannot be modified, it is possible to configure and apply a non-default network-queue policy (including a port-scheduler-policy, if required) at PXC sub-port level. An example of how this would be applied is

shown in the following output. Where redundant PXC ports are used in an LAG instance, the queue-policy is applied to all member links of the LAG, for consistency.

```
# on PE-5:
configure
  port pxc-2.a {
    admin-state enable
    ethernet {
      network {
        egress {
          queue-policy "non-default"
        }
      }
    }
  }
  port pxc-3.a {
    admin-state enable
    ethernet {
      network {
        egress {
          queue-policy "non-default"
        }
      }
    }
  }
}
```

To demonstrate QoS continuity through the FPE, the following is established:

- **Downstream:** Traffic is generated from test port C (connected to PE-5) toward test port B (connected to CE-4) with DiffServ marking EF at a rate of 100 packets/s. At PE-5 SAP ingress, this traffic is mapped into FC EF.
- **Upstream:** Traffic is generated from test port B (connected to CE-4) toward test port C (connected to PE-5) with DiffServ marking EF at a rate of 100 packets/s. At PE-3, a SAP-ingress QoS policy is used to map the traffic into FC EF.
- The default network QoS policy 1 is used on all network interfaces at PE-3 and PE-5. On egress, this policy marks FC EF as MPLS EXP 5. On ingress, MPLS EXP 5 is mapped to FC EF.
- The default network queue-policy "default" is used on all network interfaces at PE-3 and PE-5. This maps FC EF traffic to queue 6 at ingress and egress.

First, QoS continuity for downstream traffic is validated. The following output shows the relatively simple SAP-egress QoS policy that is applied to the egress of the VPRN interface (pw-port) toward CE-4. No classification of traffic and mapping to FCs are present in the policy, because the classification and mapping have already taken place on the SAP ingress at PE-5 (the SAP facing the test port C).

```
# on PE-5:
configure {
  qos {
    sap-egress "SAP egress 12" {
      policy-id 12
      queue 1 {
        scheduler-parent {
          scheduler-name "aggregate-rate"
          level 2
          weight 10
        }
      }
    }
    queue 2 {
      queue-type best-effort
      rate {
        pir 5000
      }
    }
  }
}
```

```
        cir max
      }
      scheduler-parent {
        scheduler-name "aggregate-rate"
        level 2
        weight 40
        cir-level 2
      }
    }
    queue 3 {
      queue-type expedited
      rate {
        pir 2000
        cir 2000
      }
      scheduler-parent {
        scheduler-name "aggregate-rate"
        cir-level 3
      }
    }
  }
  fc be {
    queue 1
  }
  fc af {
    queue 2
  }
  fc ef {
    queue 3
  }
}
```

The configuration of the Tier 1 scheduler "aggregate-rate" referenced by the child queues in the preceding SAP-egress QoS policy is as follows. The Tier 1 scheduler references a **port-scheduler-policy** using the command **port-parent**. Parenting to a port-scheduler is optional, but allows for inclusion of Preamble and IFG in the QoS scheduling algorithm, which otherwise are not included. The Tier 1 scheduler does not directly reference the port-scheduler-policy by name, but rather inherits any port-scheduler configured on the port to which the child queues are mapped. In this example, the port-scheduler-policy "port-scheduler" is applied to PXC sub-ports pxc-2.b and pxc-3.b (terminating side).

```
# on PE-5:
configure {
  qos {
    scheduler-policy "egress-hqos-scheduler" {
      tier 1 {
        scheduler "aggregate-rate" {
          rate {
            pir 1
          }
          port-parent {
          }
        }
      }
    }
    port-scheduler-policy "port-scheduler" {
    }
  }
  port pxc-2.b {
    admin-state enable
    ethernet {
      egress {
        port-scheduler-policy {
          policy-name "port-scheduler"
        }
      }
    }
  }
}
```

```

    }
  }
}
port pxc-3.b {
  admin-state enable
  ethernet {
    egress {
      port-scheduler-policy {
        policy-name "port-scheduler"
      }
    }
  }
}

```

Finally, the SAP-egress QoS policy is applied to the pw-port SAP within the VPRN. The egress H-QoS scheduler is also attached and an override of the rate is configured.

```

# on PE-5:
configure {
  service {
    vprn "VPRN 12 using PXC AS" {
      interface "to-CE-4" {
        sap pw-1:100.1024 {
          egress {
            qos {
              sap-egress {
                policy-name "SAP egress 12"
              }
              scheduler-policy {
                policy-name "egress-hqos-scheduler"
                overrides {
                  scheduler "aggregate-rate" {
                    rate {
                      pir 25000
                    }
                  }
                }
              }
            }
          }
        }
      }
    }
  }
}

```

When traffic is generated downstream from test port C toward CE-4 in FC EF at a rate of 100 packets/s, the first point of verification is the VPRN pw-port SAP egress. The following output—in classic CLI—is a **monitor** of the SAP showing that traffic is correctly mapped to queue 3.

```

*A:PE-5# monitor service id 12 sap pw-1:100.1024 rate
=====
Monitor statistics for Service 12 SAP pw-1:100.1024
=====
---snip---
-----
At time t = 11 sec (Mode: Rate)
-----
---snip---
-----
Sap per Queue Stats
-----
                Packets                Octets                % Port
                Util.
-----
---snip---

```

```
Egress Queue 3
For. In/InplusProf : 0          0          0.00
For. Out/ExcProf   : 100       51600     0.04
Dro. In/InplusProf : 0          0          0.00
Dro. Out/ExcProf   : 0          0          0.00
```

Monitoring of network interfaces does not show queue statistics (and is not supported on PXC sub-ports), but a verification of the sub-port statistics on the transit side (LAG 1) shows that packets are incrementing in ingress queue 6 on both sub-ports, as follows:

```
[/]
A:admin@PE-5# show port pxc-2.a detail | match "Ingress Queue 6" post-lines 4
Ingress Queue 6      Packets      Octets
  In Profile forwarded :    711      382518
  In Profile dropped   :     0         0
  Out Profile forwarded :     0         0
  Out Profile dropped   :     0         0
```

```
[/]
A:admin@PE-5# show port pxc-3.a detail | match "Ingress Queue 6" post-lines 4
Ingress Queue 6      Packets      Octets
  In Profile forwarded :   404      217352
  In Profile dropped   :     0         0
  Out Profile forwarded :     0         0
  Out Profile dropped   :     0         0
```

The last point of verification is the network egress interface toward PE-3. Again, a check at the physical port level shows that packets are incrementing in egress queue 6. Therefore, we can conclude that QoS/FC continuity is maintained in the downstream direction.

```
[/]
A:admin@PE-5# show port 1/1/2 detail | match "Egress Queue 6" post-lines 4
Egress Queue 6      Packets      Octets
  In/Inplus Prof fwded :  2394     1297548
  In/Inplus Prof dropped:    0         0
  Out/Exc Prof fwded   :    0         0
  Out/Exc Prof dropped :    0         0
```

Next, the upstream QoS continuity is verified. PE-3 is marking traffic generated by test port B to FC EF, which in turn is marked as MPLS EXP 5 by PE-3's default network QoS policy. The following output taken at PE-5 shows that packets are incrementing in ingress queue 6 of the network interface toward PE-3 and confirms that traffic is correctly marked as FC EF at ingress.

```
[/]
A:admin@PE-5# show port 1/1/2 detail | match "Ingress Queue 6" post-lines 4
Ingress Queue 6      Packets      Octets
  In Profile forwarded :   3458     1874236
  In Profile dropped   :     0         0
  Out Profile forwarded :     0         0
  Out Profile dropped   :     0         0
```

The next point of verification is the egress side of the PXC sub-ports (pxc-2.a and pxc-3.a) forming the transit side (LAG 1). The sub-port statistics verify that packets are incrementing in egress queue 6 of both sub-ports (as traffic is being load-balanced).

```
[/]
A:admin@PE-5# show port pxc-2.a detail | match "Egress Queue 6" post-lines 4
Egress Queue 6      Packets      Octets
```

```

In/Inplus Prof fwded : 12441          6693258
In/Inplus Prof dropped: 0              0
Out/Exc Prof fwded   : 0              0
Out/Exc Prof dropped : 0              0

```

```

[/]
A:admin@PE-5# show port pxc-3.a detail | match "Egress Queue 6" post-lines 4
Egress Queue 6          Packets          Octets
In/Inplus Prof fwded   : 12893          6936434
In/Inplus Prof dropped: 0              0
Out/Exc Prof fwded    : 0              0
Out/Exc Prof dropped  : 0              0

```

PXC sub-ports operate in hybrid mode. When the upstream traffic arrives on the PXC sub-ports that form the terminating side of the FPE (pxc-2.b and pxc-3.b), it is mapped to the pw-port SAP-ingress queues, bypassing the ingress network QoS policy and associated ingress network queues. As a result, the MPLS EXP-to-FC mapping cannot be fulfilled and traffic requires reclassification and remapping to the correct FC by the SAP-ingress QoS policy. The following output shows the SAP-ingress QoS policy applied to the pw-port SAP within the VPRN. Because the EXP-to-FC mapping could not be completed, FC reclassification is required in order to map traffic to its original FC before transiting the FPE. In this example, DSCP is used. Also, FC EF is mapped to queue 3.

```

#on PE-5:
configure {
  qos {
    sap-ingress "SAP ingress 12" {
      policy-id 12
      queue 1 {
        scheduler-parent {
          scheduler-name "aggregate-rate"
          level 2
          weight 10
        }
      }
      queue 2 {
        queue-type best-effort
        scheduler-parent {
          scheduler-name "aggregate-rate"
          level 2
          weight 40
          cir-level 2
        }
        rate {
          pir 5000
          cir max
        }
      }
      queue 3 {
        queue-type expedited
        scheduler-parent {
          scheduler-name "aggregate-rate"
          cir-level 3
        }
        rate {
          pir 2000
          cir 2000
        }
      }
      queue 11 {
        rate {
          cir max

```

```

    }
  }
  dscp be {
    fc "be"
  }
  dscp af31 {
    fc "af"
  }
  dscp ef {
    fc "ef"
  }
  fc "af" {
    queue 2
  }
  fc "be" {
    queue 1
  }
  fc "ef" {
    queue 3
  }
}

```

For completeness, the configuration of the Tier 1 scheduler "aggregate-rate" referenced by the child queues in the preceding SAP-ingress QoS policy is as follows. Unlike the egress counterpart, there is no parenting to a port-scheduler because this is an egress function only.

```

# on PE-5:
configure {
  qos {
    scheduler-policy "ingress-hqos-scheduler" {
      tier 1 {
        scheduler "aggregate-rate" {
          rate {
            pir 1
          }
        }
      }
    }
  }
}

```

The SAP-ingress QoS policy is applied to the pw-port SAP within the VPRN, together with the ingress H-QoS scheduler. An override of the scheduler rate is also applied.

```

# on PE-5:
configure {
  service {
    vprn "VPRN 12 using PXC AS" {
      interface "to-CE-4" {
        sap pw-1:100.1024 {
          ingress {
            qos {
              sap-ingress {
                policy-name "SAP ingress 12"
              }
              scheduler-policy {
                policy-name "ingress-hqos-scheduler"
                overrides {
                  scheduler "aggregate-rate" {
                    rate {
                      pir 25000
                    }
                  }
                }
              }
            }
          }
        }
      }
    }
  }
}

```

}

With the SAP-ingress policy applied, a monitor output of the SAP in the following output—in classic CLI—verifies that the packets are being received in queue 3 at a rate of 100 packets/s. This verifies the FC continuity in the upstream direction, noting that reclassification and remapping of FC is required at SAP ingress.

```
*A:PE-5# monitor service id 12 sap pw-1:100.1024 rate
=====
Monitor statistics for Service 12 SAP pw-1:100.1024
=====
---snip---
-----
Sap Statistics
-----
---snip---
---snip---
Packets
Octets
---snip---
Ingress Queue 3 (Unicast) (Priority)
Off. HiPrio      : 0           0           0.00
Off. LowPrio     : 100        51647      0.04
Dro. HiPrio     : 0           0           0.00
Dro. LowPrio    : 0           0           0.00
For. InProf     : 0           0           0.00
For. OutProf    : 100        51647      0.04
```

OAM continuity

The FPE pw-port functionality may be used by redundant routers to provide resilient service termination for a Layer 2 backhaul node implementing a mechanism such as active/standby pseudowire. In SR OS, an active/standby pseudowire is modeled as an Epipe or VPLS service with an endpoint object containing two spoke-SDPs. This form of redundancy relies on the propagation of the Pseudowire Status TLV within an LDP Notification message to convey the operational status of the pseudowires and thereby indicate which one of the pseudowires is active and which one is standby.

The FPE construct uses the concept of a multi-segment pseudowire, implementing Switching-PE (S-PE) functionality to instantiate dynamic cross-connects through the FPE. To verify that LDP status signaling is maintained through this S-PE function, the following is established:

- The Epipe service at PE-3 used for Layer 2 backhaul to the FPE is modified to include an **endpoint** object referenced by two spoke-SDPs.
- The first spoke-SDP has a far end of PE-2 and is configured as **precedence primary**, so becomes the active pseudowire.
- The second spoke-SDP has a far end of PE-5 and is configured with the default precedence 4, so becomes the standby pseudowire.
- Because the endpoint object is configured for **standby-signaling-master**, PE-3 will signal a status of standby toward PE-5.

For completeness, the configuration of the Epipe service at PE-3 is as follows:

```
# on PE-3:
configure {
  service {
```

```

epipe "Epipe 13" {
  admin-state enable
  service-id 13
  customer "1"
  endpoint "redundant-Layer3" {
    standby-signaling master
  }
  spoke-sdp 32:13 {
    endpoint {
      name "redundant-Layer3"
      precedence primary
    }
  }
  spoke-sdp 35:13 {
    endpoint {
      name "redundant-Layer3"
    }
  }
  sap 1/1/3:100.* {
  }
}

```

As shown in the following output, PE-3 has the spoke-SDP to PE-5 (sdp 35:13) as administratively and operationally up, but is signaling a status of standby (pwFwdingStandby).

```

[/]
A:admin@PE-3# show service id 13 sdp 35:13 detail
Admin State      : Up                Oper State      : Up
Local Pw Bits    : pwFwdingStandby
Peer Pw Bits     : None
Admin State      : Disabled          Oper State      : Disabled

```

At PE-5, the signaled status is acknowledged at the far end of the pseudowire in the Peer Pw Bits field.

```

[/]
A:admin@PE-5# show service id 13 sdp 53:13 detail
Admin State      : Up                Oper State      : Up
Local Pw Bits    : None
Peer Pw Bits     : pwFwdingStandby
Admin State      : Disabled          Oper State      : Disabled

```

Typically, an S-PE would propagate the status TLV received from one pseudowire segment into the opposing pseudowire segment in order to provide end-to-end status signaling. However, when using FPE, the SR OS Service Manager process correlates between a pseudowire and its corresponding pw-port SAPs, so can take the necessary actions based upon the operational state of each. Therefore, it is not necessary for the S-PE to propagate the status TLV from one segment to another. This is illustrated in the following output at PE-5, which shows the second segment of the multi-segment pseudowire toward the terminating side fpe_1.b. As described, the status bits are not copied between single segments and all local/peer pseudowire bits remain unset.

```

[/]
A:admin@PE-5# show service id 13 sdp 17280:1 detail
Admin State      : Up                Oper State      : Up
Local Pw Bits    : None
Peer Pw Bits     : None
Admin State      : Disabled          Oper State      : Disabled

```

The pw-port 1 used throughout in this example is internally bound to SDP 17281:

```
[/]
A:admin@PE-5# show pw-port 1

=====
PW Port Information
=====
PW Port   Encap          SDP:VC-Id          IfIndex
-----
1         qinq           17281:100001      1526726657
=====
```

The following output shows that SDP 17281 is operationally down with the flag "stitchingSvcTxDown":

```
[/]
A:admin@PE-5# show service sdp 17281 detail | match "SDP: 17281 Pw-port: 1" post-lines 10
SDP: 17281 Pw-port: 1
-----
VC-Id           : 100001           Admin Status      : up
Encap           : qinq             Oper Status       : down
VC Type         : ether
Dot1Q Ethertype : 0x8100           QinQ Ethertype    : 0x8100
Control Word    : Not Preferred
Entropy Label   : Disabled

Admin Ingress label : 524280           Admin Egress label : 524281
Oper Flags        : stitchingSvcTxDown
```

At service level, the first of the following two outputs shows the state of the SAP bound to pw-port 1. As shown, the operational state is down with an indication that this is due to the port being operationally down. The second output shows that this SAP status is propagated to IP interface level because the interface "to-CE-4" is also shown as operationally down.

```
[/]
A:admin@PE-5# show service id 12 sap pw-1:100.1024 detail | match 'Admin State|Flags'
Admin State      : Up           Oper State        : Down
Flags           : PortOperDown
```

```
[/]
A:admin@PE-5# show router 12 interface "to-CE-4"

=====
Interface Table (Service: 12)
=====
Interface-Name      Adm    Opr(v4/v6)  Mode    Port/SapId
IP-Address          PfxState
-----
to-CE-4             Up     Down/Down   VPRN    pw-1:100.1024
192.168.45.2/30    n/a
-----
Interfaces : 1
=====
```

To verify a failover, the state of the active/standby pseudowire is transitioned by failing the active pseudowire between PE-3 and PE-2. This causes PE-3 to declare the pseudowire to PE-5 active, which clears the standby status bits. This action causes the SDP (17281) bound to pw-port 1 to become

operationally up, followed by pw-port 1 and its associated SAPs, followed by the VPRN IP interface "to-CE-4".

```
208 2021/05/25 11:34:33.485 CEST MINOR: SVCMGR #2103 Base
"Status of service 2147483649 (customer 1) changed to administrative state: up, operational
state: up"

209 2021/05/25 11:34:33.485 CEST MINOR: SVCMGR #2313 Base
"Status of SDP Bind 53:13 in service 13 (customer 1) peer PW status bits changed to none"

210 2021/05/25 11:34:33.486 CEST MAJOR: SVCMGR #2210 Base
"Processing of an access port state change event is finished and the status of all affected
SAPs on port pw-1 has been updated."

211 2021/05/25 11:34:33.486 CEST WARNING: SNMP #2005 vprn12 to-CE-4
"Interface to-CE-4 is operational"
```

This example in the AS mode section illustrated how notification of a downstream failure is propagated through the components of the PXC in AS mode and reflected in the status of the pw-port (and its associated services). Also, if a pw-port fails due to a PXC failure (for example, the physical port fails), it is just as important that the operational state is propagated externally. In the case of pseudowire backhaul (as in the example), this would be achieved by setting the LDP pseudowire status bits to psnIngressFault and psnEgressFault toward the far end.

Conclusion

This chapter demonstrates the principles of PXC configuration. The PXC can be used to provide a relatively simple back-to-back cross-connect operation in DVSM mode, or it can be used in AS mode to provide an integrated path through the FPE with automated cross-connects used to simplify the provisioning process. In both DVSM mode and AS mode, the PXC can be configured as redundant or non-redundant. A relatively simple use-case of terminating an Epipe into a VPRN has been demonstrated for both modes.

There are a large number of use-cases where frame/packet preprocessing is required before service termination. The workaround for these use-cases has previously been a physical external loop, but can now be resolved logically and internally through use of the PXC.

Customer document and product support



Customer documentation

[Customer documentation welcome page](#)



Technical support

[Product support portal](#)



Documentation feedback

[Customer documentation feedback](#)