



7450 Ethernet Service Switch  
7750 Service Router  
7950 Extensible Routing System  
Virtualized Service Router  
Releases up to 24.7.R2

## Services Overview Advanced Configuration Guide for MD CLI

---

3HE 20807 AAAB TQZZA  
Edition: 01  
October 2024

Nokia is committed to diversity and inclusion. We are continuously reviewing our customer documentation and consulting with standards bodies to ensure that terminology is inclusive and aligned with the industry. Our future customer documentation will be updated accordingly.

---

This document includes Nokia proprietary and confidential information, which may not be distributed or disclosed to any third parties without the prior written consent of Nokia.

This document is intended for use by Nokia's customers ("You"/"Your") in connection with a product purchased or licensed from any company within Nokia Group of Companies. Use this document as agreed. You agree to notify Nokia of any errors you may find in this document; however, should you elect to use this document for any purpose(s) for which it is not intended, You understand and warrant that any determinations You may make or actions You may take will be based upon Your independent judgment and analysis of the content of this document.

Nokia reserves the right to make changes to this document without notice. At all times, the controlling version is the one available on Nokia's site.

No part of this document may be modified.

NO WARRANTY OF ANY KIND, EITHER EXPRESS OR IMPLIED, INCLUDING BUT NOT LIMITED TO ANY WARRANTY OF AVAILABILITY, ACCURACY, RELIABILITY, TITLE, NON-INFRINGEMENT, MERCHANTABILITY OR FITNESS FOR A PARTICULAR PURPOSE, IS MADE IN RELATION TO THE CONTENT OF THIS DOCUMENT. IN NO EVENT WILL NOKIA BE LIABLE FOR ANY DAMAGES, INCLUDING BUT NOT LIMITED TO SPECIAL, DIRECT, INDIRECT, INCIDENTAL OR CONSEQUENTIAL OR ANY LOSSES, SUCH AS BUT NOT LIMITED TO LOSS OF PROFIT, REVENUE, BUSINESS INTERRUPTION, BUSINESS OPPORTUNITY OR DATA THAT MAY ARISE FROM THE USE OF THIS DOCUMENT OR THE INFORMATION IN IT, EVEN IN THE CASE OF ERRORS IN OR OMISSIONS FROM THIS DOCUMENT OR ITS CONTENT.

Copyright and trademark: Nokia is a registered trademark of Nokia Corporation. Other product names mentioned in this document may be trademarks of their respective owners.

© 2024 Nokia.

---

# Table of contents

List of tables.....	4
List of figures.....	5
Preface.....	7
BGP Selective Label-IPv4 Route Installation.....	8
G.8032 Ethernet Ring Protection Multiple Ring Topology.....	24
G.8032 Ethernet Ring Protection Single Ring Topology.....	63
GRE Tunnel Origination and Termination Using Non-system IP Addresses.....	83
Inter-AS Option B Label Security for IP-VPN and EVPN Routes.....	100
Network Group Encryption Helper.....	122
Seamless BFD Application — Auto-bind tunnel.....	134

---

# List of tables

Table 1: Selective BGP-LU installation logic by service type.....	9
Table 2: Terminology comparison.....	26
Table 3: Untrusted interfaces with default-forwarding forward option allow all IP-VPN and EVPN routes...	101
Table 4: BGP neighbor-trust defines what traffic is allowed on untrusted interfaces with default-forwarding drop option.....	102

# List of figures

Figure 1: Example topology.....	10
Figure 2: VPRN 1 uses a BGP transport tunnel with endpoint 192.0.1.21 on PE-2.....	14
Figure 3: VPRN 2, VPLS 3, and Epipe 4 use user-provisioned SDP 1 with BGP tunnel.....	18
Figure 4: PE-1 receives BGP-VPLS and BGP-AD routes with next-hop 192.0.1.23.....	20
Figure 5: G.8032 major ring and subring.....	27
Figure 6: G.8032 ring components.....	28
Figure 7: G.8032 subring interconnection components.....	29
Figure 8: Ethernet example topology.....	33
Figure 9: ETH-CFM MEP associations.....	35
Figure 10: Subring to VPLS topology.....	57
Figure 11: G.8032 operation and topologies.....	65
Figure 12: Example topology.....	66
Figure 13: Ethernet CFM configuration.....	70
Figure 14: Example topology.....	86
Figure 15: Mismatched T-LDP transport addresses.....	88
Figure 16: Matching T-LDP transport addresses.....	89
Figure 17: L2 services on PE-1 and PE-2.....	91
Figure 18: L3 services on PE-1 and PE-2.....	96
Figure 19: Example topology with services on PEs.....	103
Figure 20: Example topology with services on PEs and on ASBR-2.....	119
Figure 21: General architecture using an NGE helper.....	123

---

Figure 22: BGP topology for learning BGP label routes.....	126
Figure 23: NGE helper for BGP VPLS or BGP VPWS using GRE SDPs with auto-GRE SDP.....	128
Figure 24: S-BFD session establishment – continuity check.....	135
Figure 25: Example topology.....	136
Figure 26: Primary path of SR-TE LSP via PE-4.....	143
Figure 27: Remote failure in the primary path of the SR-TE LSP.....	144
Figure 28: SR-TE LSP reconnects after retry timer expires.....	146

# Preface

## About This Guide

Each Advanced Configuration Guide is organized alphabetically and provides feature and configuration explanations, CLI descriptions, and overall solutions. The Advanced Configuration Guide chapters are written for and based on several Releases, up to 24.7.R2. The Applicability section in each chapter specifies on which release the configuration is based.

The Advanced Configuration Guides supplement the user configuration guides listed in the 7450 ESS, 7750 SR, and 7950 XRS Guide to Documentation.

## Audience

This manual is intended for network administrators who are responsible for configuring the routers. It is assumed that the network administrators have a detailed understanding of networking principles and configurations.

# BGP Selective Label-IPv4 Route Installation

This chapter provides information about BGP selective label-IPv4 route installation.

Topics in this chapter include:

- [Applicability](#)
- [Overview](#)
- [Configuration](#)
- [Conclusion](#)

## Applicability

The information and configuration in this chapter are based on SR OS Release 23.3.R1. BGP selective label-IPv4 route installation is supported in SR OS Release 19.10.R2, and later.

## Overview

Many service providers use BGP label-unicast (BGP-LU) to build network designs that connect multiple domains into unified and scalable network fabrics. However, the number of BGP-LU IPv4 routes that are distributed in the control plane can exceed the capacity of the Forwarding Information Base (FIB) and Label Forwarding Information Base (LFIB) of small access routers.

One solution is to apply import policies on the access router to limit the number of BGP-LU IPv4 routes accepted in the RIB-IN, but this is labor-intensive and prone to errors. A better solution is selective BGP-LU IPv4 route installation in the base routing instance, which addresses these issues.

When the **selective-label-ipv4-install** command is configured in the **bgp** context of the base router, BGP-LU IPv4 routes in the RIB-IN are made invalid if they are received from a base router BGP peer and not needed by any eligible service. When a BGP-LU IPv4 route is invalid in the RIB-IN, the BGP decision process prefers any valid route over this route, and the invalid BGP-LU IPv4 route is not programmed as a next-hop (primary next-hop, ECMP next-hop, or backup next-hop) of any IP route or tunnel.

The **selective-label-ipv4-install** command can be configured in the **bgp** context of the base router: in the global **bgp** context, the group context, or the neighbor context, as follows:

```
[/]  
A:admin@PE-1# tree flat detail | match selective-label-ipv4-install  
configure groups group <string> router <string> bgp group <string> selective-label-ipv4-install  
<boolean>  
configure groups group <string> router <string> bgp neighbor <string | ipv4-address-with-zone  
| ipv4-address | ipv6-address-linklocal-with-zone | ipv6-address | ipv6-address-with-zone>  
selective-label-ipv4-install <boolean>  
configure groups group <string> router <string> bgp selective-label-ipv4-install <boolean>  
configure router <string> bgp group <string> selective-label-ipv4-install <boolean>  
configure router <string> bgp neighbor <ipv4-address-with-zone | ipv4-address | ipv6-address-  
linklocal-with-zone | ipv6-address | ipv6-address-with-zone> selective-label-ipv4-install  
<boolean>
```



```
configure router <string> bgp selective-label-ipv4-install <boolean>
```

When a BGP-LU IPv4 route is invalid in the RIB-IN, it is marked with the flag Label-Unicast-No-Svc and the invalid route is handled as follows:

- No route for the IPv4 prefix is added to the route table from the BGP-LU RIB.
- No BGP tunnel for the /32 IPv4 prefix is added to the tunnel table.
- No RIB-OUT is generated for the invalid BGP-LU route, so this invalid route does not trigger a label-swap (incoming label map - ILM) entry to be programmed.



**Note:**

Configuring the **selective-label-ipv4-install** command on a BGP session unconditionally invalidates all non-/32 BGP-LU IPv4 routes received on that session, because those non-/32 routes are never used to resolve service endpoints.

[Table 1: Selective BGP-LU installation logic by service type](#) shows how BGP-LU IPv4 routes are handled when the selective-label-ipv4-install command is configured.

*Table 1: Selective BGP-LU installation logic by service type*

Service type	Logic marks BGP label-IPv4 routes as invalid except
<b>L2 services with user-provisioned SDPs</b>	When the user-provisioned SDP has a BGP tunnel as transport and the far end matches a /32 BGP-LU IPv4 route, that route is not marked as invalid, regardless of the operational state of the SDP.
<b>L2 services with auto-created SDPs (BGP-AD, BGP-VPLS, BGP-EVPN)</b>	If an L2 service imports a BGP-AD, BGP-VPLS, or BGP-EVPN route, /32 BGP-LU IPv4 routes matching the BGP next-hop address of this BGP route are not marked as invalid.
<b>EVPN next-hop-self route reflector or model-B ASBR</b>	If the base router BGP instance is configured as a next-hop-self RR or a model-B ASBR, BGP-LU IPv4 routes matching any IPv4 address in the BGP next-hop field of a received EVPN route are not marked as invalid, regardless of whether the transport-tunnel resolution filter allows BGP tunnels.
<b>VPRN with explicitly configured SDP</b>	BGP-LU IPv4 routes matching the SDP far-end address are not marked as invalid, regardless of the operational state of the SDP.
<b>VPRN with auto-bind-tunnel</b>	If the auto-bind VPRN service imports VPN-IPv4 or VPN-IPv6 routes where the BGP next-hop matches a BGP-LU IPv4 route, that route is not marked as invalid, regardless of whether the auto-bind-tunnel resolution filter allows BGP tunnels.
<b>VPN-IP next-hop-self RR or model-B ASBR</b>	If the base router BGP instance is configured as a next-hop-self RR or a model-B ASBR, BGP-LU IPv4 routes matching any IPv4 address in the BGP next-hop field of a received VPN-IP route are not marked as invalid, regardless

Service type	Logic marks BGP label-IPv4 routes as invalid except
	of whether the transport-tunnel resolution filter allows BGP tunnels.

## Configuration

Figure 1: Example topology shows the example topology with two PEs with the services that are configured.

Figure 1: Example topology

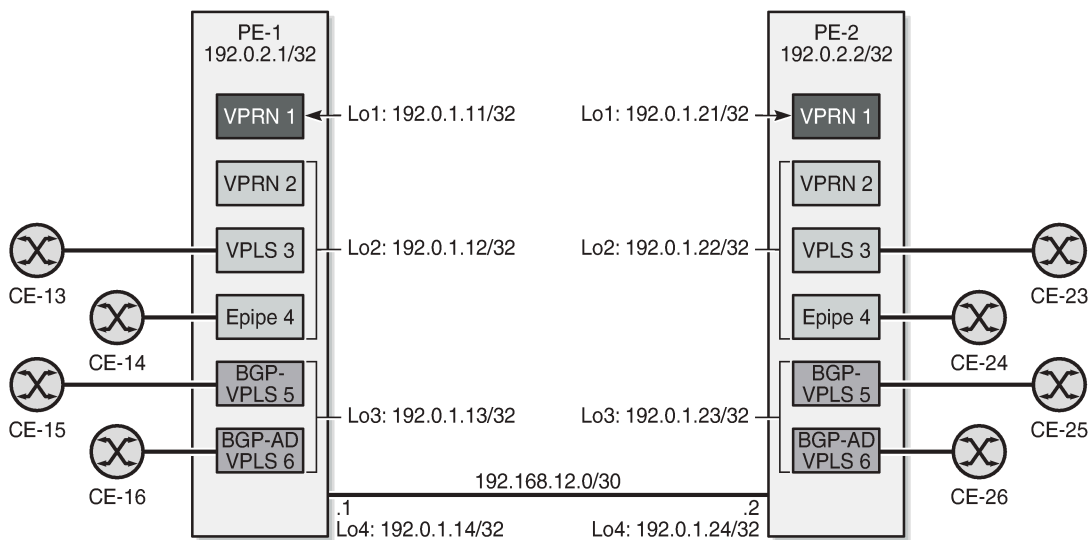

35965

## Initial configuration

The initial configuration on the PEs includes:

- Cards, MDAs, ports
- Router interfaces
- SR-ISIS

On PE-2, four loopback interfaces are configured in the base router context with /32 IPv4 addresses: 192.0.1.21/32, 192.0.1.22/32, 192.0.1.23/32, and 192.0.1.24/32. The list of router interfaces on PE-2 is as follows:

```
[/]
A:admin@PE-2# show router interface
```

```
=====
Interface Table (Router: Base)
=====
```

Interface-Name IP-Address	Adm	Opr(v4/v6)	Mode	Port/SapId PfxState
int-PE-2-PE-1 192.168.12.2/30	Up	Up/Down	Network	1/1/c1/2:100 n/a
lo1 192.0.1.21/32	Up	Up/Down	Network	loopback n/a
lo2 192.0.1.22/32	Up	Up/Down	Network	loopback n/a
lo3 192.0.1.23/32	Up	Up/Down	Network	loopback n/a
lo4 192.0.1.24/32	Up	Up/Down	Network	loopback n/a
system 192.0.2.2/32	Up	Up/Down	Network	system n/a

-----  
 Interfaces : 6  
 =====

These prefixes are exported as BGP-LU routes and the next-hop resolution filter for label-IPv4 routes is configured with SR-ISIS. The configuration on PE-2 is as follows:

```
# on PE-2:
configure {
  policy-options {
    prefix-list "192.0.1.0/24" {
      prefix 192.0.1.0/24 type range {
        start-length 32
        end-length 32
      }
    }
  }
  policy-statement "export-svc-lu-bgp" {
    entry 10 {
      from {
        prefix-list ["192.0.1.0/24"]
      }
      action {
        action-type accept
      }
    }
  }
}
router "Base" {
  bgp {
    split-horizon true
    ebgp-default-reject-policy {
      import false
      export false
    }
    next-hop-resolution {
      labeled-routes {
        transport-tunnel {
          family label-ipv4 {
            resolution-filter {
              ldp false
              sr-isis true
            }
          }
        }
      }
    }
  }
}
group "iBGPv4" {
  peer-as 64500
}
```

```

    family {
      vpn-ipv4 true
      label-ipv4 true
    }
  }
  neighbor "192.0.2.1" {
    group "iBGPv4"
    export {
      policy ["export-svc-lu-bgp"]
    }
  }
}

```

PE-1 receives four valid label-IPv4 routes, as follows:

```

[/]
A:admin@PE-1# show router bgp routes label-ipv4
=====
BGP Router ID:192.0.2.1      AS:64500      Local AS:64500
=====
Legend -
Status codes : u - used, s - suppressed, h - history, d - decayed, * - valid
               l - leaked, x - stale, > - best, b - backup, p - purge
Origin codes  : i - IGP, e - EGP, ? - incomplete
=====
BGP LABEL-IPV4 Routes
=====
Flag  Network                               LocalPref  MED
      Nexthop (Router)                     Path-Id    IGP Cost
      As-Path                               Label
-----
u*>i  192.0.1.21/32                          100        None
      192.0.2.2                             None       10
      No As-Path                             524286
u*>i  192.0.1.22/32                          100        None
      192.0.2.2                             None       10
      No As-Path                             524286
u*>i  192.0.1.23/32                          100        None
      192.0.2.2                             None       10
      No As-Path                             524286
u*>i  192.0.1.24/32                          100        None
      192.0.2.2                             None       10
      No As-Path                             524286
-----
Routes : 4
=====

```

The tunnel table on PE-1 includes four BGP tunnels toward the loopback interfaces on PE-2:

```

[/]
A:admin@PE-1# show router tunnel-table protocol bgp
=====
IPv4 Tunnel Table (Router: Base)
=====
Destination      Owner    Encap TunnelId  Pref  Nexthop      Metric
  Color
-----
192.0.1.21/32    bgp     MPLS  262148   12   192.0.2.2    1000
192.0.1.22/32    bgp     MPLS  262147   12   192.0.2.2    1000
192.0.1.23/32    bgp     MPLS  262146   12   192.0.2.2    1000

```

```

192.0.1.24/32      bgp      MPLS 262145  12    192.0.2.2    1000
-----
Flags: B = BGP or MPLS backup hop available
      L = Loop-Free Alternate (LFA) hop available
      E = Inactive best-external BGP route
      k = RIB-API or Forwarding Policy backup hop
=====
  
```

The route table on PE-1 shows four BGP-LU IPv4 routes toward the loopback interfaces on PE-2, with next-hop resolved via an SR-ISIS tunnel:

```

[/]
A:admin@PE-1# show router route-table protocol bgp-label

=====
Route Table (Router: Base)
=====
Dest Prefix[Flags]                Type  Proto  Age           Pref
Next Hop[Interface Name]          Metric
-----
192.0.1.21/32                     Remote BGP_LABEL 00h01m12s 170
192.0.2.2 (tunneled:SR-ISIS:524290) 10
192.0.1.22/32                     Remote BGP_LABEL 00h01m12s 170
192.0.2.2 (tunneled:SR-ISIS:524290) 10
192.0.1.23/32                     Remote BGP_LABEL 00h01m12s 170
192.0.2.2 (tunneled:SR-ISIS:524290) 10
192.0.1.24/32                     Remote BGP_LABEL 00h01m12s 170
192.0.2.2 (tunneled:SR-ISIS:524290) 10
-----
No. of Routes: 4
Flags: n = Number of times nexthop is repeated
      B = BGP backup route available
      L = LFA nexthop available
      S = Sticky ECMP requested
=====
  
```

The tunnel toward destination 192.0.2.2 is the following SR-ISIS tunnel:

```

[/]
A:admin@PE-1# show router tunnel-table 192.0.2.2

=====
IPv4 Tunnel Table (Router: Base)
=====
Destination      Owner      Encap TunnelId  Pref  Nexthop      Metric
Color
-----
192.0.2.2/32    isis (0)  MPLS  524290   11    192.168.12.2  10
-----
Flags: B = BGP or MPLS backup hop available
      L = Loop-Free Alternate (LFA) hop available
      E = Inactive best-external BGP route
      k = RIB-API or Forwarding Policy backup hop
=====
  
```

In the following examples, services that use these BGP tunnels are configured .

## VPRN 1 with auto-bind-tunnel

VPRN 1 in [Figure 2: VPRN 1](#) uses a BGP transport tunnel with endpoint 192.0.1.21 on PE-2 uses the BGP transport tunnel between loopback interfaces "lo1" with IP address 192.0.1.11/32 on PE-1 and 192.0.1.21/32 on PE-2.

Figure 2: VPRN 1 uses a BGP transport tunnel with endpoint 192.0.1.21 on PE-2

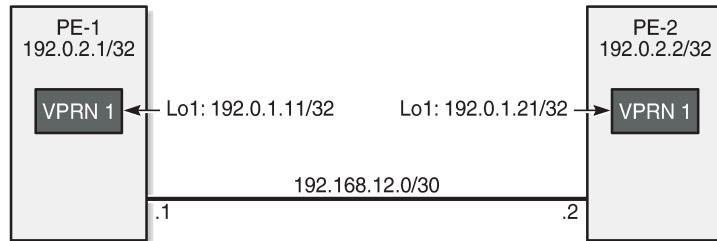

35966

VPRN 1 is configured with an auto-bind-tunnel and the next-hop must be resolved using a BGP tunnel. On PE-2, the policy "export-VPRN1" sets the next-hop to 192.0.1.21 and adds the community "target:64500:1", which matches the vrf-target of VPRN 1.

```
# on PE-2:
configure {
  policy-options {
    community "target:64500:1" {
      member "target:64500:1" { }
    }
    policy-statement "export-VPRN1" {
      entry 10 {
        action {
          action-type accept
          next-hop 192.0.1.21
          community {
            add ["target:64500:1"]
          }
        }
      }
    }
  }
  service {
    vprn "VPRN 1" {
      admin-state enable
      service-id 1
      customer "1"
      bgp-ipvpn {
        mpls {
          admin-state enable
          route-distinguisher "64500:1"
          vrf-target {
            community "target:64500:1"
          }
        }
        vrf-export {
          policy ["export-VPRN1"]
        }
        auto-bind-tunnel {
          resolution filter
        }
      }
    }
  }
}
```

```

    }
  }
  interface "lo1" {
    loopback true
    ipv4 {
      primary {
        address 172.31.1.2
        prefix-length 32
      }
    }
  }
}

```

The configuration is similar on PE-1, but the IP addresses are different.

VRPN 1 on PE-1 receives a BGP VPN-IPv4 route for prefix 172.31.1.2/32 from PE-2. The next-hop of this BGP-VPN route is 192.0.1.21:

```

[/]
A:admin@PE-1# show router bgp routes vpn-ipv4
=====
BGP Router ID:192.0.2.1      AS:64500      Local AS:64500
=====
Legend -
Status codes  : u - used, s - suppressed, h - history, d - decayed, * - valid
                l - leaked, x - stale, > - best, b - backup, p - purge
Origin codes  : i - IGP, e - EGP, ? - incomplete
=====
BGP VPN-IPv4 Routes
=====
Flag  Network                               LocalPref  MED
      Nexthop (Router)                     Path-Id    IGP Cost
      As-Path                               Label
-----
u*>i  64500:1:172.31.1.2/32                  100        None
      192.0.1.21                             None        0
      No As-Path                               524285
-----
Routes : 1
=====

```

VRPN 1 on PE-1 uses the BGP tunnel toward 192.0.1.21/32 while the other BGP tunnels are not required on PE-1. When BGP is configured with the **selective-label-ipv4-install** command, only the BGP-LU IPv4 route for 192.0.1.21/32 remains valid. The command can be configured in the global BGP context (as in the following configuration), per **group**, or per **neighbor**:

```

# on PE-1:
configure {
  router "Base" {
    bgp {
      selective-label-ipv4-install true
    }
  }
}

```

From the four BGP transport tunnels on PE-1, only the BGP tunnel with endpoint 192.0.1.21/32 is used by a service, so it remains valid, as follows:

```

[/]
A:admin@PE-1# show router bgp routes label-ipv4
=====

```

```

BGP Router ID:192.0.2.1      AS:64500      Local AS:64500
=====
Legend -
Status codes  : u - used, s - suppressed, h - history, d - decayed, * - valid
                l - leaked, x - stale, > - best, b - backup, p - purge
Origin codes  : i - IGP, e - EGP, ? - incomplete
=====
BGP LABEL-IPV4 Routes
=====
Flag  Network                               LocalPref  MED
      Nexthop (Router)                     Path-Id    IGP Cost
      As-Path                               Label
-----
u*>i 192.0.1.21/32                          100        None
      192.0.2.2                             None       10
      No As-Path                             524286
i     192.0.1.22/32                          100        None
      192.0.2.2                             None       10
      No As-Path                             524286
i     192.0.1.23/32                          100        None
      192.0.2.2                             None       10
      No As-Path                             524286
i     192.0.1.24/32                          100        None
      192.0.2.2                             None       10
      No As-Path                             524286
-----
Routes : 4
=====
  
```

The first label-IPv4 route is valid; the other three label-IPv4 routes are marked invalid with flag Label-Unicast-No-Svc:

```

[/]
A:admin@PE-1# show router bgp routes label-ipv4 hunt | match Flags
Flags      : Used Valid Best IGP In-TTM In-RTM
Flags      : Invalid IGP Label-Unicast-No-Svc
Flags      : Invalid IGP Label-Unicast-No-Svc
Flags      : Invalid IGP Label-Unicast-No-Svc
  
```

In the route table on PE-1, only one BGP-LU IPv4 route remains:

```

[/]
A:admin@PE-1# show router route-table protocol bgp-label

Route Table (Router: Base)
=====
Dest Prefix[Flags]                Type  Proto  Age      Pref
  Next Hop[Interface Name]                               Metric
-----
192.0.1.21/32                      Remote BGP_LABEL 00h02m05s 170
  192.0.2.2 (tunneled:SR-ISIS:524290) 10
-----
No. of Routes: 1
Flags: n = Number of times nexthop is repeated
      B = BGP backup route available
      L = LFA nexthop available
      S = Sticky ECMP requested
=====
  
```



## L2 and L3 services with user-provisioned SDP

When SDPs are configured to use a BGP transport tunnel, the corresponding BGP label-IPv4 route is not marked as invalid. The following TLDP-signaled SDP is configured with a BGP transport tunnel between the loopback interfaces "lo2" with IP address 192.0.1.12 on PE-1 and 192.0.1.22 on PE-2:

```
# on PE-2:
configure {
  router "Base" {
    ldp {
      targeted-session {
        peer 192.0.1.12 {
          local-lsr-id {
            interface-name "lo2"
          }
        }
      }
    }
  }
}
service {
  sdp 1 {
    admin-state enable
    delivery-type mpls
    bgp-tunnel true
    far-end {
      ip-address 192.0.1.12
    }
  }
}
```

The configuration is similar on PE-1; only the far-end and peer address is now 192.0.1.22:

```
[/]
A:admin@PE-1# show service sdp

=====
Services: Service Destination Points
=====
SdpId  AdmMTU  OprMTU  Far End           Adm  Opr           Del  LSP  Sig
-----
1      0       8970    192.0.1.22      Up   Up            MPLS B    TLDP
-----
Number of SDPs : 1
-----
Legend: R = RSVP, L = LDP, B = BGP, M = MPLS-TP, n/a = Not Applicable
        I = SR-ISIS, O = SR-OSPF, T = SR-TE, F = FPE
=====
```

When an SDP uses a BGP transport tunnel, the corresponding BGP label-IPv4 route is not marked as invalid, regardless of the operational state of the SDP. The following command shows that the second BGP label-IPv4 route is now valid:

```
[/]
A:admin@PE-1# show router bgp routes label-ipv4

=====
BGP Router ID:192.0.2.1      AS:64500      Local AS:64500
=====
Legend -
Status codes : u - used, s - suppressed, h - history, d - decayed, * - valid
```

```

l - leaked, x - stale, > - best, b - backup, p - purge
Origin codes : i - IGP, e - EGP, ? - incomplete
=====
BGP LABEL-IPV4 Routes
=====
Flag Network                               LocalPref MED
  Nexthop (Router)                        Path-Id  IGP Cost
  As-Path                                  Label
-----
u*>i 192.0.1.21/32                          100      None
      192.0.2.2                             None     10
      No As-Path                             524286
u*>i 192.0.1.22/32                          100      None
      192.0.2.2                             None     10
      No As-Path                             524286
i     192.0.1.23/32                          100      None
      192.0.2.2                             None     10
      No As-Path                             524286
i     192.0.1.24/32                          100      None
      192.0.2.2                             None     10
      No As-Path                             524286
-----
Routes : 4
=====
  
```

This SDP can be used by L2 and L3 services. [Figure 3: VPRN 2, VPLS 3, and Epipe 4 use user-provisioned SDP 1 with BGP tunnel](#) shows three services that use SDP 1: VPRN 2, VPLS 3, and Epipe 4.

Figure 3: VPRN 2, VPLS 3, and Epipe 4 use user-provisioned SDP 1 with BGP tunnel

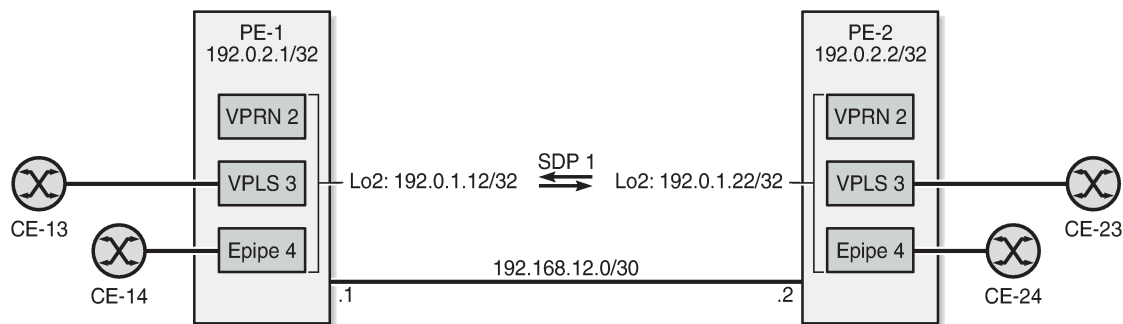

35967

VPRN 2 is similar to VPRN 1, but a spoke-SDP is configured instead of the auto-bind-tunnel. The configuration is as follows:

```

# on PE-1:
configure {
  policy-options {
    community "target:64500:2" {
      member "target:64500:2" { }
    }
  }
  policy-statement "export-VPRN2" {
    entry 10 {
      action {
        action-type accept
        next-hop 192.0.1.12
        community {
          add ["target:64500:2"]
        }
      }
    }
  }
}
  
```

```

    }
  }
}
service {
  vprn "VPRN 2" {
    admin-state enable
    service-id 2
    customer "1"
    bgp-ipvpn {
      mpls {
        admin-state enable
        route-distinguisher "64500:2"
        vrf-target {
          community "target:64500:2"
        }
        vrf-export {
          policy ["export-VPRN2"]
        }
      }
    }
    interface "lo1" {
      loopback true
      ipv4 {
        primary {
          address 172.31.2.1
          prefix-length 32
        }
      }
    }
    spoke-sdp 1:2 {
    }
  }
}

```

VPLS 3 and Epipe 4 only have a spoke-SDP and a SAP, as follows:

```

# on PE-1:
configure {
  service {
    vpls "VPLS 3" {
      admin-state enable
      service-id 3
      customer "1"
      spoke-sdp 1:3 {
      }
      sap 1/1/c2/1:3 {
      }
    }
    epipe "Epipe 4" {
      admin-state enable
      service-id 4
      customer "1"
      spoke-sdp 1:4 {
      }
      sap 1/1/c2/1:4 {
      }
    }
  }
}

```

## L2 services with auto-created SDPs

Figure 4: PE-1 receives BGP-VPLS and BGP-AD routes with next-hop 192.0.1.23 shows two VPLS services where the SDPs are auto-created between the loopback interfaces "lo3" on the PEs: BGP-VPLS 5 and BGP-AD VPLS 6.

Figure 4: PE-1 receives BGP-VPLS and BGP-AD routes with next-hop 192.0.1.23

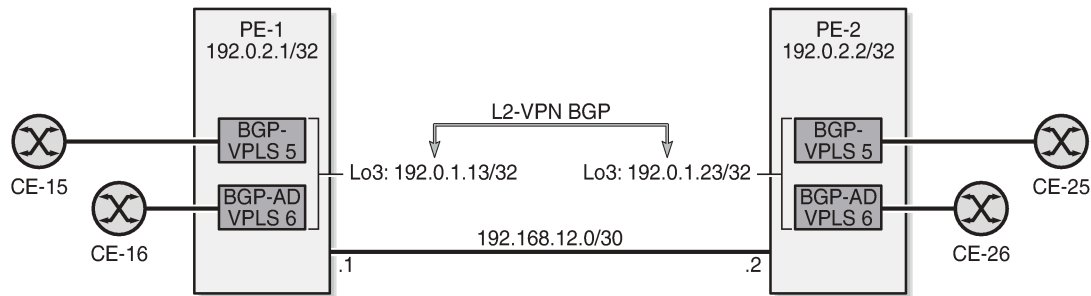

35968

For BGP-VPLS and BGP-AD, a BGP session is established for the L2-VPN address family between the loopback interfaces "lo3" on both PEs:

```
# on PE-2:
configure {
  router "Base" {
    bgp {
      group "iBGP-L2" {
        type internal
        local-address 192.0.1.23
        family {
          l2-vpn true
        }
      }
      neighbor "192.0.1.13" {
        group "iBGP-L2"
      }
    }
  }
}
```

For BGP-AD, T-LDP signaling is used, so the following T-LDP session is established:

```
# on PE-2:
configure {
  router "Base" {
    ldp {
      targeted-session {
        peer 192.0.1.13 {
          local-lsr-id {
            interface-name "lo3"
          }
        }
      }
    }
  }
}
```

The service configuration is as follows:

```
# on PE-2:
configure {
  service {
    vpls "BGP-VPLS 5" {
```

```

admin-state enable
service-id 5
customer "1"
bgp 1 {
  route-distinguisher "64500:5"
  route-target {
    export "target:64500:5"
    import "target:64500:5"
  }
  pw-template-binding "PW1" {
    import-rt ["target:64500:5"]
  }
}
bgp-vpls {
  admin-state enable
  maximum-ve-id 100
  ve {
    name "PE-2"
    id 2
  }
}
sap 1/1/c2/1:5 {
}
}
vpls "BGP-AD VPLS 6" {
  admin-state enable
  service-id 6
  customer "1"
  bgp 1 {
    route-distinguisher "64500:6"
    route-target {
      export "target:64500:6"
      import "target:64500:6"
    }
    pw-template-binding "PW1" {
    }
  }
  bgp-ad {
    admin-state enable
    vpls-id "64500:6"
    vsi-id-prefix 192.0.1.23
  }
  sap 1/1/c2/1:6 {
  }
}
}

```

On PE-1, the received L2-VPN BGP routes have next-hop 192.0.1.23:

```

[/]
A:admin@PE-1# show router bgp routes l2-vpn
=====
BGP Router ID:192.0.2.1      AS:64500      Local AS:64500
=====
Legend -
Status codes  : u - used, s - suppressed, h - history, d - decayed, * - valid
                l - leaked, x - stale, > - best, b - backup, p - purge
Origin codes  : i - IGP, e - EGP, ? - incomplete
=====
BGP L2VPN Routes
=====
Flag  RouteType      Prefix      MED
     RD              SiteId      Label

```

	NextHop As-Path	VeId BaseOffset	BlockSize vplsLabelBase	LocalPref
u*>i	VPLS	-	-	0
	64500:5	-	-	-
	<b>192.0.1.23</b>	2	8	100
	No As-Path	1	524276	
u*>i	AutoDiscovery	192.0.1.23	-	0
	64500:6	-	-	-
	<b>192.0.1.23</b>	-	-	100
	No As-Path	-	-	

-----  
 Routes : 2  
 =====

On PE-1, the following SDPs with far-end address 192.0.1.23 are auto-created in BGP-VPLS 5 and BGP-AD VPLS 6:

```
[/]
A:admin@PE-1# show service id 5 sdp

=====
Services: Service Destination Points
=====
SdpId          Type      Far End addr  Adm   Opr      I.Lbl  E.Lbl
-----
32766:4294967294 BgpVpls  192.0.1.23   Up    Up       524277 524276
-----
Number of SDPs : 1
-----
=====
```

```
[/]
A:admin@PE-1# show service id 6 sdp

=====
Services: Service Destination Points
=====
SdpId          Type      Far End addr  Adm   Opr      I.Lbl  E.Lbl
-----
32767:4294967295 BgpAd     192.0.1.23   Up    Up       524273 524263
-----
Number of SDPs : 1
-----
=====
```

BGP-VPLS 5 and BGP-AD VPLS 6 use a BGP transport tunnel between the "lo3" interfaces, so the corresponding BGP label-IPv4 route is valid, as follows:

```
[/]
A:admin@PE-1# show router bgp routes label-ipv4

=====
BGP Router ID:192.0.2.1      AS:64500      Local AS:64500
=====
Legend -
Status codes : u - used, s - suppressed, h - history, d - decayed, * - valid
               l - leaked, x - stale, > - best, b - backup, p - purge
Origin codes  : i - IGP, e - EGP, ? - incomplete
=====
```

```

BGP LABEL-IPV4 Routes
=====
Flag  Network                               LocalPref  MED
      Nexthop (Router)                 Path-Id    IGP Cost
      As-Path                           Label
-----
u*>i  192.0.1.21/32                         100        None
      192.0.2.2                          None       10
      No As-Path                          524286
u*>i  192.0.1.22/32                         100        None
      192.0.2.2                          None       10
      No As-Path                          524286
u*>i  192.0.1.23/32                       100        None
      192.0.2.2                          None       10
      No As-Path                          524286
i     192.0.1.24/32                       100        None
      192.0.2.2                          None       10
      No As-Path                          524286
-----
Routes : 4
=====
  
```

Only the BGP tunnel between the "lo4" interfaces is not used by any service, so the last BGP label-IPv4 route is marked invalid in the RIB-IN when **selective-label-ipv4-install** is configured on PE-1, as follows:

```

[/]
A:admin@PE-1# show router bgp routes label-ipv4 hunt | match "Invalid" pre-lines 16

Network       : 192.0.1.24/32
Nexthop       : 192.0.2.2
Path Id       : None
From          : 192.0.2.2
Res. Nexthop  : 192.0.2.2 (ISIS Tunnel)
Local Pref.   : 100
Aggregator AS : None
Atomic Aggr.  : Not Atomic
AIGP Metric   : None
Connector     : None
Community     : No Community Members
Cluster       : No Cluster Members
Originator Id : None
Fwd Class     : None
IPv4 Label    : 524286
Flags       : Invalid IGP Label-Unicast-No-Svc
Interface Name : NotAvailable
Aggregator     : None
MED            : None
IGP Cost       : 10
Peer Router Id : 192.0.2.2
Priority       : None
  
```

## Conclusion

The **selective-label-ipv4-install** command allows BGP-LU IPv4 routes to be marked as invalid in the RIB-IN when these routes are received from a base router BGP peer and not needed by any eligible service. This is a technique to reduce the number of routes in the FIB/LFIB, which is mainly useful for small access routers having small FIB/LFIB sizes.

# G.8032 Ethernet Ring Protection Multiple Ring Topology

This chapter provides information about G.8032 Ethernet ring protection multiple ring topologies.

Topics in this chapter include:

- [Applicability](#)
- [Overview](#)
- [Configuration](#)
- [Conclusion](#)

## Applicability

Initially, this chapter was written for SR OS Release 12.0.R5, but the MD-CLI in this edition is based on Release 23.3.R2.

## Overview

G.8032 Ethernet ring protection is supported for data service SAPs within a regular VPLS service, a PBB VPLS (I/B-component), or a routed VPLS (R-VPLS). G.8032 is one of the fastest protection schemes for Ethernet networks. This chapter describes the advanced topic of multiple ring control, sometimes referred to as multi-chassis protection, with access rings being the most common form of multiple ring topologies. Single rings are covered in the [G.8032 Ethernet Ring Protection Single Ring Topology](#) chapter. This chapter will use a VPLS service to illustrate the configuration of G.8032. For very large ring topologies, provider backbone bridging (PBB) can also be used, but that is not configured in this chapter.

ITU-T G.8032v2 specifies protection switching mechanisms and a protocol for Ethernet layer network (ETH) Ethernet rings. Ethernet rings can provide wide-area multipoint connectivity more economically due to their reduced number of links. The mechanisms and protocol defined in ITU-T G.8032v2 are highly reliable with stable protection and never form loops, which would negatively affect network operation and service availability. Each ring node is connected to adjacent nodes participating in the same ring using two independent paths, which use ring links (configured on ports or link aggregation groups (LAGs)). A ring link is bounded by two adjacent nodes and a port for a ring link is called a ring port. The minimum number of nodes on a ring is two.

The fundamentals of this ring protection switching architecture are:

- the principle of loop avoidance and
- the utilization of learning, forwarding, and address table mechanisms defined in the ITU-T G.8032v2 Ethernet flow forwarding function (ETH\_FF) (control plane).

Loop avoidance in the ring is achieved by guaranteeing that, at any time, traffic may flow on all but one of the ring links. This particular link is called the ring protection link (RPL) and under normal conditions this link is blocked, so it is not used for traffic. One designated node, the RPL owner, is responsible to



block traffic over the one designated RPL. Under a ring failure condition, the RPL owner is responsible for unblocking the RPL, allowing the RPL to be used for traffic. The protocol ensures that even without an RPL owner defined, one link will be blocked and it operates as a *break before make* protocol, specifically the protocol guarantees that no link is restored until a different link in the ring is blocked. The other side of the RPL is configured as an RPL neighbor. An RPL neighbor blocks traffic on the RPL.

The event of a ring link or ring node failure results in protection switching of the traffic. This is achieved under the control of the ETH\_FF functions on all ring nodes. A ring automatic protection switching (R-APS) protocol is used to coordinate the protection actions over the ring. The protection switching mechanisms and protocol supports a multi-ring/ladder network that consists of connected Ethernet rings.

## Ring protection mechanism

The ring protection protocol is based on the following building blocks:

- ring status change on failure
  - idle → link failure → protection → recovery → idle
- ring control state changes
  - idle → protection → manual switch → forced switch → pending
- re-use existing ETH OAM
  - monitoring: ETH continuity check messages (CCM)
  - failure notification: Y.1731 signal failure
- forwarding database MAC flush on ring status change
- ring protection link (RPL)
  - defines blocked link in idle status

When subrings are used, they can either connect to a major ring (which is configured in the exact same way as a single ring) or another subring, or to a VPLS service. When connected to a major ring or to a subring, there is the option to extend the subring control service through the major ring or not. This gives the following three options for subring connectivity:

- 1. subring to a major ring or to a subring with a virtual channel** — In this case, a data service on the major ring or subring is created which is used to forward the R-APS messages for the subring over the major ring or subring, between the interconnection points of the subring to the major ring or subring. This allows the subring to operate as a fully connected ring and is mandatory if the subring connects two major rings or subrings because the virtual channel is the only mechanism that the subrings can use to exchange control messages. It also could improve failover times if the subring was large as it provides two paths on the subring interconnection nodes to propagate the fault indication around the subring, whereas without a virtual channel the fault indication may need to traverse the entire subring. Each subring requires its own data service on the major ring or subring for the virtual channel.
- 2. subring to a major ring or to a subring without a virtual channel** — In this case the subring is not fully connected and does not require any resources on the major ring or subring. This option requires that the R-APS messages are not blocked on the subring over its RPL.
- 3. subring to a VPLS service** — This is similar to the preceding option, but it uses a VPLS service instead of a major ring or subring. In this option, subring failures can initiate the sending of an LDP MAC flush message into the VPLS service when spoke or MPLS mesh SDPs are used in the VPLS service.

## Ethernet ring terminology

The implementation of Ethernet ring on SR OS uses a VPLS as the construct for a ring flow function (one for ETH\_FF (solely for control) and one for each service\_FF) and SAPs (on ports or LAGs) as ring links. The control VPLS must be a regular VPLS, but the data VPLS can be a regular VPLS, a PBB (B/I-) VPLS or a routed VPLS. The state of the data service SAPs is inherited from the state of the control service SAPs. [Table 2: Terminology comparison](#) displays a comparison between the ITU-T and SR OS terminologies.

Table 2: Terminology comparison

ITU-T G.8032v2 terminology	SR OS terminology
ETH_FF	control vpls
service_FF	data vpls
east ring link	path a
west ring link	path b
RPL owner	rpl-node owner
RPL link	path {a b} rpl-end
MEP	control-mep
ERP control process	eth-ring instance or ring-id
major ring	eth-ring
sub-ring	eth-ring sub-ring
ring node	ring node PE
ring-ID	not used; fixed at 1 per G.8032v2

There are various ways that multiple rings can be interconnected and the possible topologies may be large. Customers typically have two forms of networks: access ring edge networks or larger multiple ring networks. Both topologies require ring interconnection.

[Figure 5: G.8032 major ring and subring](#) shows a ring of six nodes, with a major ring (regular Ethernet ring) on the top four nodes and a subring on the bottom.

Figure 5: G.8032 major ring and subring

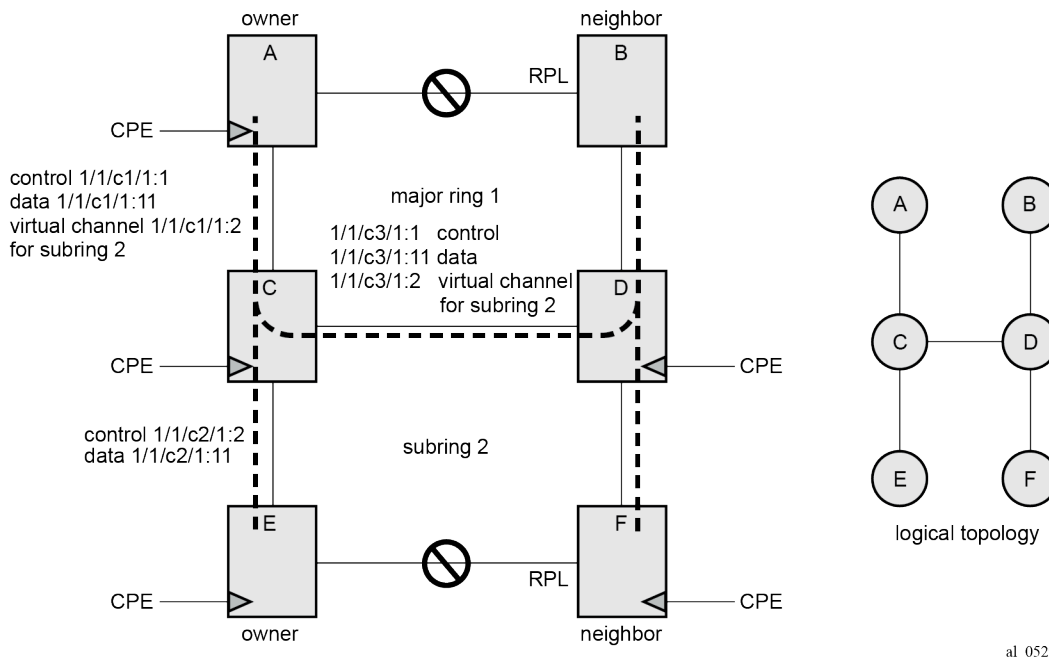

A major ring is a fully connected ring. A subring is a partial ring that depends on a major ring or a VPLS topology for part of the ring interconnect. Two major rings can be connected by a single subring. A subring can support other subrings.

In the major ring (on nodes A, B, C, and D), one path of the RPL owner is designated to be the RPL and the respective SAPs will be blocked in order to prevent a loop. The choice of where to put the RPL is up to the network administrator and can be different for different control instances of the ring allowing an RPL to be used for some other ring's traffic. In the subring, one path is designated as the RPL and will be blocked. Both the major ring and the subring have their own RPL. The subring interconnects to the major ring on nodes C and D and has a virtual channel on the major ring. SR OS supports both virtual channel and non-virtual channel rings. Schematics of the physical and logical topologies are also shown in [Figure 5: G.8032 major ring and subring](#).

The G.8032 protocol defines a ring ID (1-255). The SR OS implementation only uses ring ID 1, which complies with G.8032v2. The configuration on a node uses a ring instance with a number but all rings use ring ID 1. This ring instance number is purely local and does not have to match on other ring nodes. Only the VLAN ID must match between SR OS ring nodes. For consistency in this example, VPLS instances and Ethernet ring instances are shown as matching for the same ring.

An RPL owner and RPL neighbor are configured for both the major ring and subring. The path and associated link will be the RPL when the ring is fully operational and will be blocked by the RPL owner whenever there is no fault on other ring links. Each ring RPL is independent. If a different ring link fails, then the RPL will be unblocked by the RPL owner. The link shared between a subring and the major ring is completely controlled by the major ring as if the subring were not there. Each ring can completely protect one fault within its ring. When the failed link recovers, it will initially be blocked by one of its adjacent nodes. The adjacent node sends an R-APS message across the ring to indicate the error is cleared and after a configurable time, if reversion is enabled, the RPL will revert to being blocked with all other links unblocked. This ensures that the ring topology when fully operational is predictable.

If a specific RPL owner is not configured (not recommended by G.8032 specification), then the last link to become active will be blocked and the ring will remain in this state until another link fails. This operation makes the selection of the blocked link non-deterministic.

The protection protocol uses a specific control VLAN, with the associated data VLANs taking their forwarding state from the control VLAN. The control VLAN cannot carry data.

### Load balancing with multiple ring instances

Each control ring is independent of the other control rings on the same topology. Therefore, because the RPL is used by one control ring, it is often desirable to set up a second control ring that uses a different link as RPL. This spreads out traffic in the topology, but if there is a link failure in the ring, all traffic will be on the remaining links. In the following examples, only a single control ring instance is configured. Other control and data rings could be configured if desired.

### Provider backbone bridging (PBB)

PBB services also support G.8032 as data services (the services used for the control VPLS must be a regular VPLS). B/I-VPLS rings support both major rings and subrings. B-VPLS rings support multi-chassis link aggregation group (MC-LAG) as a dual homing option when aggregating I-VPLS traffic onto a B-VPLS ring. In other words, I-VPLS rings should not be dual-homed into two backbone edge bridge (BEB) nodes where the B-VPLS uses G.8032 to get connected to the rest of the B-VPLS network because the only mechanism that can propagate MAC flushes between an I-VPLS and B-VPLS is an LDP MAC flush.

### SR OS implementation

G.8032 is built from VPLS components and each ring consists of the configuration components illustrated in [Figure 6: G.8032 ring components](#).

Figure 6: G.8032 ring components

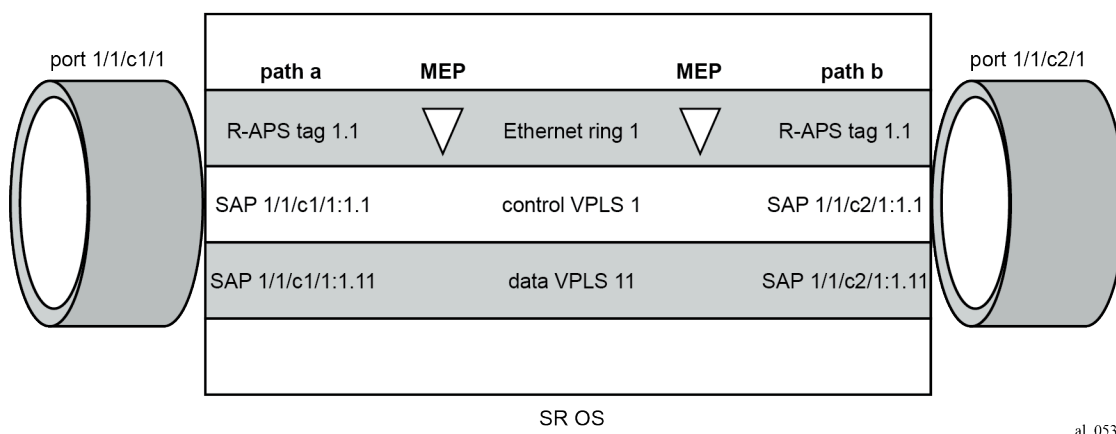

These components consist of:

- the Ethernet ring instance which defines the R-APS tags, the MEPs, and the ring behavior.
- the control VPLS which has SAPs with an encapsulation that matches the R-APS tags.

- the data VPLS which is linked to the ring. All of the data VPLS SAPs follow the operational state of the control VPLS SAPs in that each blocked SAP controlled by the ring is blocked for all control and data instances.

Figure 7: G.8032 subring interconnection components shows the major ring and subring interconnection components:

Figure 7: G.8032 subring interconnection components

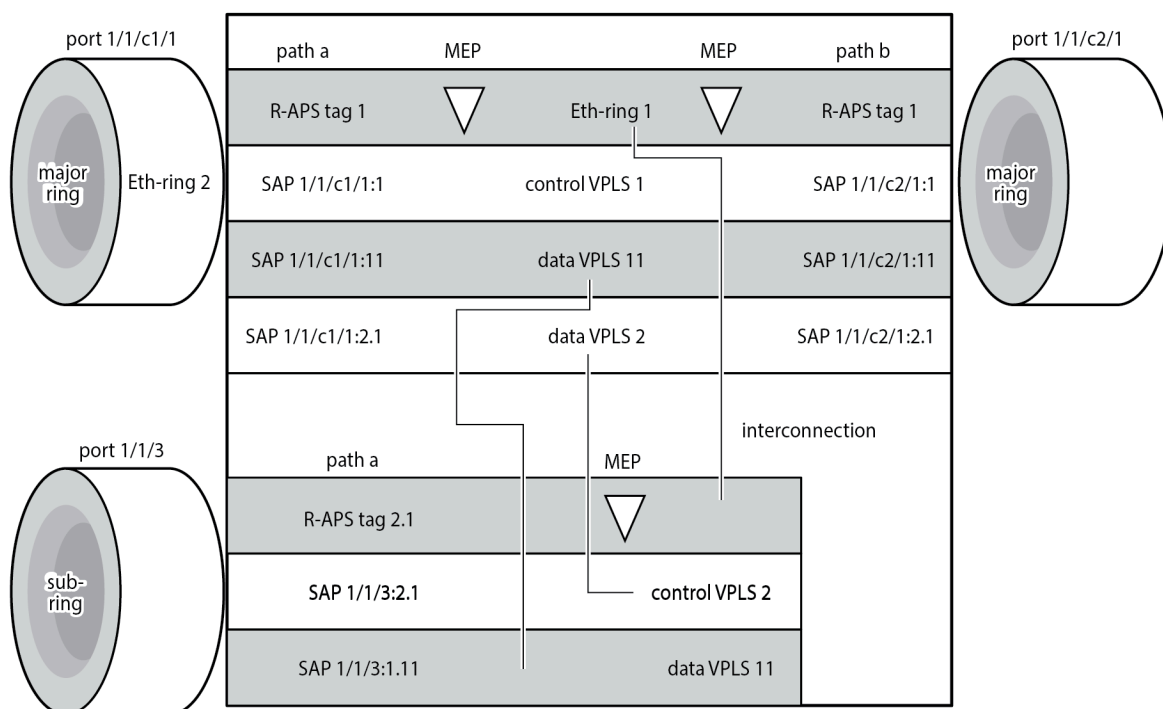

26167

For a subring, the configuration is the same as a single ring except at the junction of the major ring and the subring. The interconnection of a subring and a major ring links the control VPLS of the subring to a data VPLS of the major ring when a virtual link is used. Similarly, the data VPLS of the subring is linked to a data VPLS of the major ring. Figure 7: G.8032 subring interconnection components illustrates the relationship of a subring and a major ring. Because this subring has a virtual channel, the data VPLS 2 has both data SAPs from the subring and data SAPs from the major ring. The virtual channel is also optional and in non-virtual-link cases, no VPLS instance is required (see non-virtual-link in the section Configuration of a subring to a VPLS service).

In Figure 7: G.8032 subring interconnection components, the inner tag values are kept the same for clarity, but in fact any encapsulation that is consistent with the next ring link will work. In other words, ring SAPs can perform VLAN ID translation and even when connecting a subring to a major ring. This also means that other ports may reuse the same tags when connecting independent services.

The R-APS tags and SAPs on the rings can either be dot1Q or QinQ encapsulated. It is also possible to have the control VPLS using single tagged frames with the data VPLSs using double tagged frames; this requires the system to be configured with the **extended-default-qinq-sap-lookup** parameter (**configure service system extended-default-qinq-sap-lookup true**), with the ring path R-APS tags and control VPLS SAPs configured as qtag.0, and the data VPLSs configured as QinQ SAP: qtag1.qtag2. Spanning tree protocol (STP) cannot be enabled on SAPs connected to Ethernet rings.

R-APS messages received from other nodes are normally blocked on the RPL interface but the subring case with non-virtual channel recommends that R-APS messages be propagated over the RPL. Configuring **sub-ring type non-virtual-link** on all nodes on the subring is required to ensure propagation of R-APS messages around the subring.

R-APS messages are forwarded out of the egress using forwarding class network control (NC) and should be prioritized accordingly in the SAP egress QoS policy to ensure that congestion does not cause R-APS messages to be dropped which could cause the ring to switch to another path.

## Configuration

This section describes the configuration of multiple rings. The Ethernet ring configuration commands are as follows.

```
configure {
  eth-ring <ring-index [1..128]> {
    ccm-hold-time {
      down <number> # Hold timer for down event dampening in centiseconds
      up <number> # Hold timer for recovery reporting in deciseconds
    }
    compatible-version <number> # [1..2] - Default: 2
    description <string>
    guard-time <number> # [1..20] in deciseconds - Default: 5
    node-id <mac-address> # MAC address of the RPL <xx:xx:xx:xx:xx:xx>
    path <string> # path ID: string of 1 character
    admin-state <keyword> # default: disable
    description <string>
    port-and-raps-tag <port-and-encap> # Port ID and ring APS tag ID
    eth-cfm {
      mep md-admin-name <reference> ma-admin-name <reference> mep-id <number> {
        admin-state <keyword> # default: disable
        ccm <boolean> # default: false
        control-mep <boolean> # default: false
      }
    }
    rpl-end <boolean> # default: false
  }
  revert-time <number> # <0,60..720> in seconds - Default: 300
  rpl-node <keyword> # owner | neighbor
  sub-ring
    interconnect {
      propagate-topology-change <boolean> # default: false
      ring-id # Ring instance of the connection ring for the subring
      vpls # Connect subring to VPLS ID that contains subring SAP
    }
    type # Subring type (virtual-link|non-virtual-link)
  }
}
```

Parameters:

- **<ring-index>** — The ring index is the number by which the ring is referenced; values: 1 to128.
- **ccm-hold-time { [down <down-timeout>] [up <up-timeout>] }**
  - **down** — This command specifies the timer which controls the delay between detecting that ring path is down and reporting it to the G.8032 protection module. If a non-zero value is configured, the system will wait for the time specified in the value parameter before reporting it to the G.8032 protection module. This parameter applies only to ring path CCM. It does not apply to the ring port

link state. To dampen ring port link state transitions, use the hold-time parameter from the physical member port. This is useful if the underlying path between two nodes is going across an optical system which implements its own protection.

- **up** — This command specifies the timer which controls the delay between detecting that ring path is up and reporting it to the G.8032 protection module. If a non-zero value is configured, the system will wait for the time specified in the value parameter before reporting it to the G.8032 protection module. This parameter applies only to ring path CCM. It does not apply to the member port link state. To dampen member port link state transitions, use the hold-time parameter from the physical member port.

Values:

```
*[ex:/configure eth-ring 1 ccm-hold-time]
A:admin@PE-1# down ?

down <number>
<number> - <1..5000> - centiseconds

    Hold timer for down event dampening

*[ex:/configure eth-ring 1 ccm-hold-time]
A:admin@PE-1# up ?

up <number>
<number> - <0..5000> - deciseconds
Default - 20

    Hold timer for recovery reporting
```

- The **admin-state** command allows to enable or disable the Ethernet ring.
- The **compatible-version** command configures the Ethernet ring compatibility version for the G.8032 state machine and messages. The default is version 2 (ITU G.8032v2) and all SR OS systems use version 2. If there is a need to interwork with third party devices that only support version 1, this can be set to version 1 allowing the reception of version 1 PDUs. Version 2 is encoded as 1 in the R-APS messages. Compatibility allows the reception of version 1 (encoded as 0) R-APS PDUs but, as per the G.8032 specification, higher versions are ignored on reception. For SR OS, messages are always originated with version 2. Therefore, if a third party switch supports version 3 (encoded as 2) or higher, interworking is also supported provided the other switch is compatible with version 2.
- The **description** includes a text string of maximum 80 characters to describe the use of the Ethernet ring.
- **guard-time <time>** — The forwarding method, in which R-APS messages are copied and forwarded at every Ethernet ring node, can result in a message corresponding to an old request, that is no longer relevant, being received by Ethernet ring nodes. Reception of an old R-APS message may result in erroneous ring state interpretation by some Ethernet ring nodes. The guard timer is used to prevent Ethernet ring nodes from acting upon outdated R-APS messages and prevents the possibility of forming a closed loop. Messages are not forwarded when the guard-timer is running.

Values:

```
*[ex:/configure eth-ring 1]
A:admin@PE-1# guard-time ?

guard-time <number>
<number> - <1..20> - deciseconds
Default - 5
```



- The **node-id** `<xx-xx-xx-xx-xx-xx>` allows the node identifier to be explicitly configured. By default, the chassis MAC is used. The node ID is not required in typical configurations.
- The **path** parameter defines the paths around the ring, of which there are two in different directions on the ring: an "a" path and a "b" path, except on the interconnection node where a subring connects to another major ring or subring in which case there is one path (either a or b) configured together with the **sub-ring** command. The paths are configured on a dot1Q or QinQ encapsulated access or hybrid port or a LAG with the encapsulation used for the R-APS messages on the ring. These can be either single tagged or double tagged.
  - The **admin-state** command allows to enable or disable the path.
  - The **port-and-raps-tag** specifies the port ID and the R-APS tag.
  - The **description** includes a text string of maximum 80 characters to describe the use of the path.
  - The **eth-cfm** context includes the associated Ethernet CFM parameters.
    - **mep md-domain-name** `<reference>` **ma-domain-name** `<reference>` **mep-id** `<number>` — The MEP defined under the path is used for the G.8032 protocol messages, which are based on IEEE 802.1ag/Y.1731 CFM frames.
  - **rpl-end** — When configured, this path is expected to be one end of the RPL. This parameter must be configured in conjunction with the **rpl-node** parameter.
- The **revert-time** command configures the revert time for an Ethernet ring. The revert time is the time that the RPL will wait before returning to the blocked state, after a failure condition has been fixed. Values: [0, 60..720] in seconds - Default: 300.
- When the **rpl-node** parameter is configured, a node can be designated as either the **owner** of the RPL, in which case this node is responsible for the RPL, or the **neighbor**, in which case the node is expected to be the neighbor to the RPL owner across the RPL. The **neighbor** parameter is optional and is included to be compliant with the specification. The **rpl-node** parameter must be configured in conjunction with the **rpl-end** command. On a subring without virtual channel it is mandatory to configure **sub-ring type non-virtual-link** on all nodes on the subring to ensure propagation of the R-APS messages around the subring.
- The **sub-ring** command is configured on the interconnection node between the subring and its major ring or subring to indicate that this ring is a subring. A ring configured as a subring can only be configured with a single path.
  - The **type** `{virtual-link|non-virtual-link}` parameter specifies whether it uses a virtual link through the major ring or subring for the R-APS messages or not.
  - **interconnect** `[ring-id <ring-index> | vpls]` — A subring connects to either another ring or to a VPLS service. If it connects to another ring (either a major ring or another subring), the ring identifier must be specified and the ring to which it connects must be configured with both a path "a" and a path "b", meaning that it is not possible to connect a subring to another subring on an interconnection node. Alternatively, the **vpls** parameter is used to indicate the subring connects to a VPLS service. Interconnection using a VPLS service requires the subring to be configured with **type non-virtual-link**.
    - **propagate-topology-change** — If a topology change event happens in the subring, it can be optionally propagated with the use of this parameter to either the major ring or subring it is connected to, using R-APS messages, or to the LDP VPLS SDP peers using an LDP "flush-all-from-me" message if the subring is connected to a VPLS service.

The example topology is shown in [Figure 8: Ethernet example topology](#).



Figure 8: Ethernet example topology

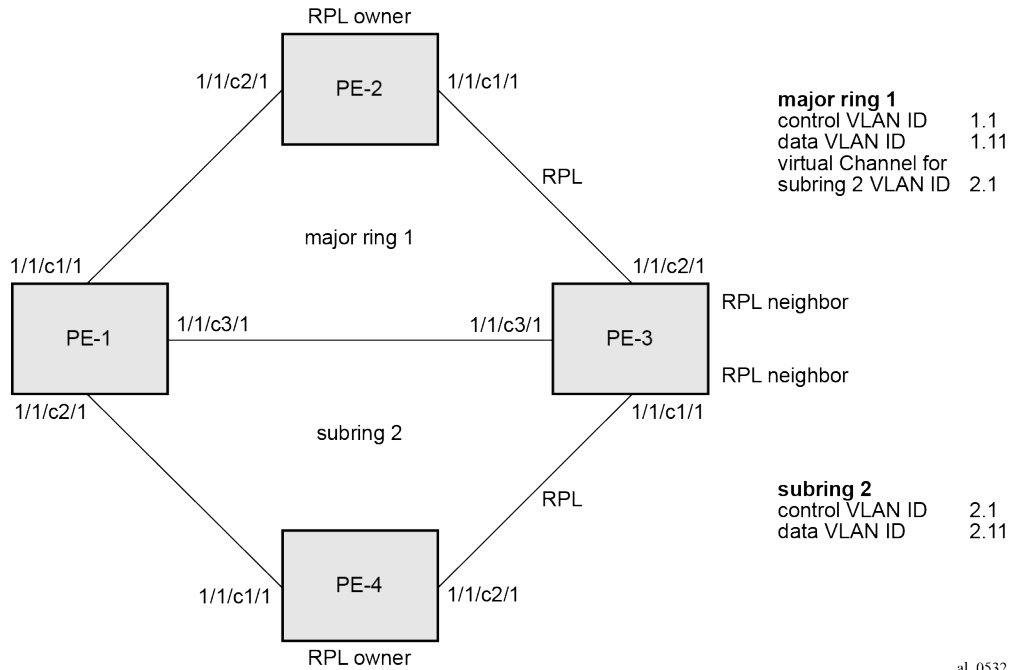

The configuration is divided into the following sections:

- a subring connected to a major ring using a virtual link through the major ring
- a subring connected to a major ring without a virtual link
- a subring connected to a VPLS service (without a virtual link)

### Configure a subring to a major ring with a virtual link

To configure an Ethernet ring using R-APS, there will be at least two VPLS services required for one Ethernet ring instance, one for the control channel and the others for data channels. The control channel is used for R-APS signaling while the data channel is for user data traffic. The state of the data channels is inherited from the state of the control channel.

The following needs to be configured:

- encapsulation type for each ring port
- Ethernet CFM
- Ethernet ring for major ring 1
- Ethernet ring for subring 2
- control channel service and Ethernet ring SAPs
- user data channel services

## Configure the encapsulation for the ring ports.

An Ethernet ring needs an R-APS tag to send and receive G.8032 signaling messages. To configure a control channel, an access SAP configuration is required on each path (a or b) port. The SAP configuration follows that of the port and must be either dot1Q or QinQ, consequently the control and data packets are either single tagged or double tagged.



### Note:

Single tagged control frames are supported on a QinQ port by configuring the system with the **extended-default-qinq-sap-lookup** parameter (**configure service system extended-default-qinq-sap-lookup true**), and the ring path R-APS tags and control VPLS SAPs configured as qtag.0.

In this example, QinQ tags are used. For example, the port configuration on PE-1 is as follows:

```
# on PE-1:
configure {
  port 1/1/c1/1 {
    admin-state enable
    ethernet {
      mode access
      encap-type qinq
    }
  }
  port 1/1/c2/1 {
    admin-state enable
    ethernet {
      mode access
      encap-type qinq
    }
  }
  port 1/1/c3/1 {
    admin-state enable
    ethernet {
      mode access
      encap-type qinq
    }
  }
}
```

## Configure Ethernet CFM

Configuring the Ethernet CFM domain, association, and MEP is required before configuring an Ethernet ring. The standard domain format is **none** and the association name must be ITU carrier code-based (ICC-based - Y.1731); however, the SR OS implementation is flexible in that it supports both IEEE and ICC formats. The Ethernet ring MEP requires a CCM interval with values such as 1s, 100ms, or 10ms to be configured.

The MEPs used for R-APS control normally will have CCM configured on the control channel path MEPs for failure detection. Alternatively, detecting a failure of the ring may be achieved by running Ethernet in the first mile (EFM) at the port level if CCM is not possible at 1s, 100ms, or 10ms. Also rings can be run without CFM although the Ethernet CFM association must be configured for R-APS messages to be exchanged. To omit the failure detecting CCMs, it is necessary to remove the **ccm true** from under the path MEPs and to remove the **remote-mep** on the corresponding ETH CFM configuration.

Loss-of-signal, in conjunction with other OAM mechanisms, is applicable only when the nodes are directly connected.

**Figure 9: ETH-CFM MEP associations** shows the details of the MEPs and their associations configured when both the major rings and subrings are used. The associations only need to be pairwise unique but for clarity five unique associations are used. Any name format can be used, but it must be consistent on both adjacent nodes.

Figure 9: ETH-CFM MEP associations

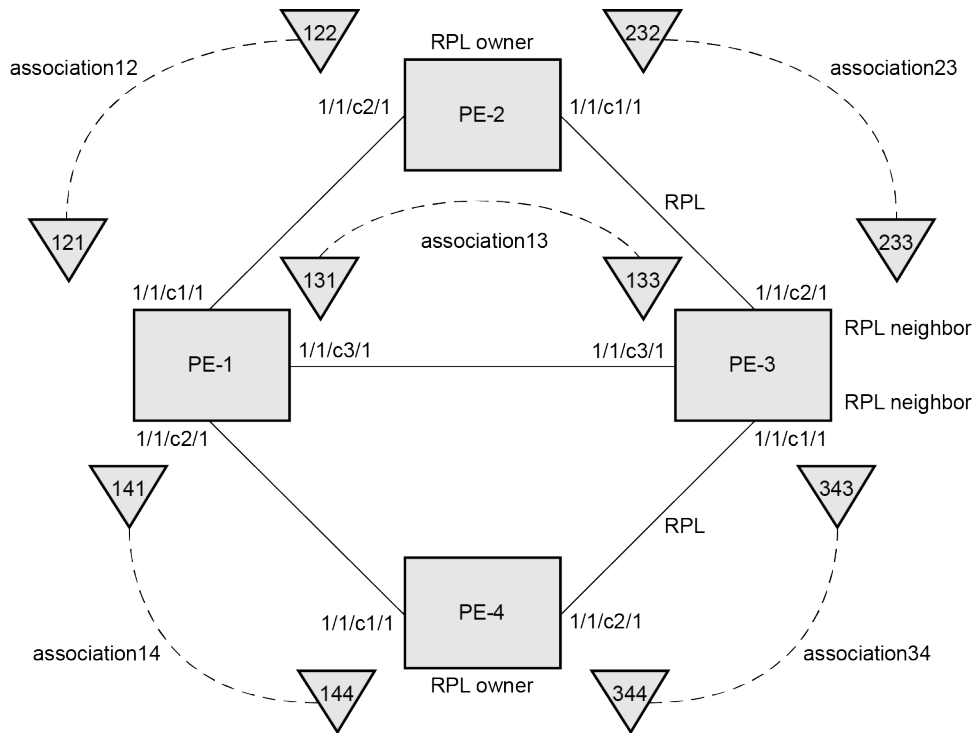

al\_0533

The configuration of Ethernet CFM for the major and subrings on each node is as follows. The CCMs for failure detection are configured for 1 second intervals.

On ring node PE-1, the associations "association-12" and "association-13" are used for the major ring and association "association-14" is used for the subring.

```
# on PE-1:
configure {
  eth-cfm {
    domain "domain-1" {
      level 2
      format none
      md-index 1
      association "association-12" {
        icc-based "Association12"
        ma-index 12
        ccm-interval 1s
        remote-mep 122 {
        }
      }
    }
    association "association-13" {
      icc-based "Association13"
    }
  }
}
```

```
        ma-index 13
        ccm-interval 1s
        remote-mep 133 {
        }
    }
    association "association-14" {
        icc-based "Association14"
        ma-index 14
        ccm-interval 1s
        remote-mep 144 {
        }
    }
}
```

On ring node PE-2, the associations "association-12" and "association-23" are used for the major ring.

```
# on PE-2:
configure {
    eth-cfm {
        domain "domain-1" {
            level 2
            format none
            md-index 1
            association "association-12" {
                icc-based "Association12"
                ma-index 12
                ccm-interval 1s
                remote-mep 121 {
                }
            }
            association "association-23" {
                icc-based "Association23"
                ma-index 23
                ccm-interval 1s
                remote-mep 233 {
                }
            }
        }
    }
}
```

On ring node PE-3, the associations "association-13" and "association-23" are used for the major ring and association "association-34" is used for the subring.

```
# on PE-3:
configure {
    eth-cfm {
        domain "domain-1" {
            level 2
            format none
            md-index 1
            association "association-13" {
                icc-based "Association13"
                ma-index 13
                ccm-interval 1s
                remote-mep 131 {
                }
            }
            association "association-23" {
                icc-based "Association23"
                ma-index 23
                ccm-interval 1s
                remote-mep 232 {
                }
            }
        }
    }
}
```

```

    }
    association "association-34" {
      icc-based "Association34"
      ma-index 34
      ccm-interval 1s
      remote-mep 344 {
      }
    }
  }
}

```

On ring node PE-4, the associations 14 and 34 are used for the subring.

```

# on PE-4
configure {
  eth-cfm {
    domain "domain-1" {
      level 2
      format none
      md-index 1
      association "association-14" {
        icc-based "Association14"
        ma-index 14
        ccm-interval 1s
        remote-mep 141 {
        }
      }
      association "association-34" {
        icc-based "Association34"
        ma-index 34
        ccm-interval 1s
        remote-mep 343 {
        }
      }
    }
  }
}

```

## Configuring Ethernet ring – major ring 1

Two paths must be configured to form a ring. In this example, VLAN tag 1.1 is used as control channel for R-APS signaling for the major ring (Ethernet ring 1) on the ports shown in [Figure 8: Ethernet example topology](#) using the Ethernet CFM information shown in [Figure 9: ETH-CFM MEP associations](#). The revert time is set to the value of 60 seconds and CCM messages are enabled on the MEP. The **control-mep true** command indicates that this MEP is used for ring R-APS messages.

The configuration of Ethernet ring 1 on ring node PE-1 is as follows:

```

# on PE-1:
configure {
  eth-ring 1 {
    admin-state enable
    description "Ethernet ring 1_major ring"
    revert-time 60
    path "a" {
      admin-state enable
      description "Ethernet ring 1_path a"
      port-and-raps-tag 1/1/c1/1:1.1
      eth-cfm {
        mep md-admin-name "domain-1" ma-admin-name "association-12" mep-id 121 {
          admin-state enable
          ccm true
          control-mep true
        }
      }
    }
  }
}

```

```

    }
  }
}
path "b" {
  admin-state enable
  description "Ethernet ring 1_path b"
  port-and-raps-tag 1/1/c3/1:1.1
  eth-cfm {
    mep md-admin-name "domain-1" ma-admin-name "association-13" mep-id 131 {
      admin-state enable
      ccm true
      control-mep true
    }
  }
}
}

```

It is mandatory to configure a MEP in the path context, otherwise the following error is displayed:

```

*[ex:/configure eth-ring 1 path "a"]
A:admin@PE-1# commit
MINOR: MGMT_CORE #4001: configure eth-ring 1 path "a" admin-state - Cannot enable path
without eth-cfm mep configured - configure eth-ring 1 path "a" admin-state

```

While MEPs are mandatory, enabling CCMs on the MEPs under the paths as a failure detection mechanism is optional as explained earlier.

Ring node PE-2 is configured as the RPL owner with the RPL being on path "a" as indicated by the **rpl-end** parameter. The revert time is 60 seconds.

```

# on PE-2:
configure {
  eth-ring 1 {
    admin-state enable
    description "Ethernet ring 1_major ring"
    revert-time 60
    rpl-node owner
    path "a" {
      admin-state enable
      description "Ethernet ring 1_path a"
      port-and-raps-tag 1/1/c1/1:1.1
      rpl-end true
      eth-cfm {
        mep md-admin-name "domain-1" ma-admin-name "association-23" mep-id 232 {
          admin-state enable
          ccm true
          control-mep true
        }
      }
    }
  }
}
path "b" {
  admin-state enable
  description "Ethernet ring 1_path b"
  port-and-raps-tag 1/1/c2/1:1.1
  eth-cfm {
    mep md-admin-name "domain-1" ma-admin-name "association-12" mep-id 122 {
      admin-state enable
      ccm true
      control-mep true
    }
  }
}
}

```

It is not permitted to configure a path as an RPL end without having configured the node on this ring to be either the RPL owner or RPL neighbor, otherwise the following error message is reported.

```
*[ex:/configure eth-ring 1 path "a"]
A:admin@PE-2# commit
MINOR: MGMT_CORE #4001: configure eth-ring 1 path "a" rpl-end - rpl-node must be set -
configure eth-ring 1 rpl-node
```

Ring node PE-3 is configured as the RPL neighbor with the RPL being on path "b" as indicated by the **rpl-end** parameter. The revert time is 60 seconds.

```
# on PE-3:
configure {
  eth-ring 1 {
    admin-state enable
    description "Ethernet ring 1_major ring"
    revert-time 60
    rpl-node neighbor
    path "a" {
      admin-state enable
      description "Ethernet ring 1_path a"
      port-and-raps-tag 1/1/c3/1:1.1
      eth-cfm {
        mep md-admin-name "domain-1" ma-admin-name "association-13" mep-id 133 {
          admin-state enable
          ccm true
          control-mep true
        }
      }
    }
  }
  path "b" {
    admin-state enable
    description "Ethernet ring 1_path b"
    port-and-raps-tag 1/1/c2/1:1.1
    rpl-end true
    eth-cfm {
      mep md-admin-name "domain-1" ma-admin-name "association-23" mep-id 233 {
        admin-state enable
        ccm true
        control-mep true
      }
    }
  }
}
```

The link between PE-2 and PE-3 will be the RPL with PE-2 and PE-3 blocking that link when the ring is fully operational. In this example, the RPL is using path "a" on PE-2 and path "b" on PE-3.

## Configuring Ethernet ring – subring 2

Ring nodes PE-1, PE-3, and PE-4 form a subring. The subring attaches to the major ring (Ethernet ring 1). The subring in this case uses a virtual link. The interconnection ring instance identifier (**ring-id 1**) is specified and **propagate-topology-change true** indicates that subring flushing will be propagated to the major ring. Only one path (path a) is specified because the other path (path b) is not required at an interconnection node. Subrings are almost identical to major rings in operation except that subrings send MAC flushes towards their connected ring (either a major ring or a subring). Major rings or subrings never send MAC flushes to their subrings. Therefore a couple of subrings connected to a major ring can

cause MACs to flush on the major ring but the major ring will not propagate a subring MAC flush to other subrings.

Ring node PE-1 provides an interconnection between the major ring (ring 1) and the subring (ring 2). Ring 2 is configured to be a subring which interconnects to ring 1. It will use a virtual link on ring 1 to send R-APS messages to the other interconnection node and topology changes will be propagated from subring 2 to the major ring 1.

```
# on PE-1:
configure {
  eth-ring 2 {
    admin-state enable
    description "Ethernet subring 2 on major ring 1"
    revert-time 60
    sub-ring {
      type virtual-link
      interconnect {
        ring-id 1
        propagate-topology-change true
      }
    }
  }
  path "a" {
    admin-state enable
    description "Ethernet subring 2_path a"
    port-and-raps-tag 1/1/c2/1:2.1
    eth-cfm {
      mep md-admin-name "domain-1" ma-admin-name "association-14" mep-id 141 {
        admin-state enable
        ccm true
        control-mep true
      }
    }
  }
}
```

Subring 2 is not configured on PE-2.

The configuration of subring 2 on PE-3 is similar to PE-1, but PE-3 is the RPL neighbor, with the RPL end on path "a", for the RPL between PE-3 and PE-4.

```
# on PE-3:
configure {
  eth-ring 2
    admin-state enable
    description "Ethernet subring 2 on major ring 1"
    revert-time 60
    rpl-node neighbor
    sub-ring {
      type virtual-link
      interconnect {
        ring-id 1
        propagate-topology-change true
      }
    }
  }
  path "a" {
    admin-state enable
    description "Ethernet subring 2_path a"
    port-and-raps-tag 1/1/c1/1:2.1
    rpl-end true
    eth-cfm {
      mep md-admin-name "domain-1" ma-admin-name "association-34" mep-id 343 {
        admin-state enable
        ccm true
      }
    }
  }
}
```



```

        control-mep true
    }
}

```

Ring node PE-4 only has configuration for the subring 2, not for major ring 1. PE-4 is the RPL owner, with path "b" being the RPL end, for the RPL between PE-3 and PE-4.

```

# on PE-4:
configure {
  eth-ring 2
    admin-state enable
    description "Ethernet subring 2"
    revert-time 60
    rpl-node owner
    path "a" {
      admin-state enable
      description "Ethernet subring 2_path a"
      port-and-raps-tag 1/1/c1/1:2.1
      eth-cfm {
        mep md-admin-name "domain-1" ma-admin-name "association-14" mep-id 144 {
          admin-state enable
          ccm true
          control-mep true
        }
      }
    }
    path "b" {
      admin-state enable
      description "Ethernet subring 2_path b"
      port-and-raps-tag 1/1/c2/1:2.1
      rpl-end true
      eth-cfm {
        mep md-admin-name "domain-1" ma-admin-name "association-34" mep-id 344 {
          admin-state enable
          ccm true
          control-mep true
        }
      }
    }
  }
}

```

Until the Ethernet ring instance is attached to a VPLS service, the ring operational status is down and the forwarding status of each port is blocked. This prevents the operator from creating a loop by misconfiguration. This state can be seen on ring node PE-1 as follows:

```

[/]
A:admin@PE-1# show eth-ring 1

=====
Ethernet Ring 1 Information
=====
Description      : Ethernet ring 1_major ring
Admin State      : Up          Oper State      : Down
Node ID          : 02:09:ff:00:00:00
Guard Time      : 5 deciseconds  RPL Node      : rplNone
Max Revert Time  : 60 seconds    Time to Revert : N/A
CCM Hold Down Time : 0 centiseconds CCM Hold Up Time : 20 deciseconds
Compatible Version : 2
APS Tx PDU       : Request State: 0xB
                  Sub-Code      : 0x0
                  Status         : 0x20 ( BPR )
                  Node ID        : 02:09:ff:00:00:00

```

```

Defect Status      :
Sub-Ring Type      : none
-----
Ethernet Ring Path Summary
-----
Path Port          Raps-Tag   Admin/Oper   Type         Fwd State
-----
a 1/1/c1/1         1.1          Up/Down     normal       blocked
b 1/1/c3/1         1.1          Up/Down     normal       blocked
=====
  
```

### Configure the control channel VPLS service

Path "a" and "b" configured in the Ethernet ring must be added as SAPs into a VPLS service (standard VPLS) using the **eth-ring** parameter. The SAP encapsulation values must match the values of the R-APS tag configured for the associated path.

G.8032 uses the same R-APS tag value on all nodes on the ring, as configured in this example. However, the SR OS implementation relaxes this constraint by requiring the tag to match only on adjacent nodes.

In this example VPLS "control-VPLS-1" is configured on PE-1, PE-2, and PE-3 for the control channel for the major ring (ring 1), and VPLS "control-VPLS-2" is used on PE-1, PE-3, and PE-4 for the subring (ring 2).

VPLS "control-VPLS-1" is the control service for the major ring and is defined for PE-1, PE-2, and PE-3, as follows:

```

# on PE-1:
configure {
  service {
    vpls "control-VPLS-1" {
      admin-state enable
      description "Control channel VID 1.1 for ring 1 - major ring"
      service-id 1
      customer "1"
      sap 1/1/c1/1:1.1 {
        eth-ring 1
      }
      sap 1/1/c3/1:1.1 {
        eth-ring 1
      }
    }
  }
}
  
```

```

# on PE-2:
configure {
  service {
    vpls "control-VPLS-1" {
      admin-state enable
      description "Control channel VID 1.1 for ring 1 - major ring"
      service-id 1
      customer "1"
      sap 1/1/c1/1:1.1 {
        eth-ring 1
      }
      sap 1/1/c2/1:1.1 {
        eth-ring 1
      }
    }
  }
}
  
```

```

}

# on PE-3:
configure {
  service {
    vpls "control-VPLS-1" {
      admin-state enable
      description "Control channel VID 1.1 for ring 1 - major ring"
      service-id 1
      customer "1"
      sap 1/1/c2/1:1.1 {
        eth-ring 1
      }
      sap 1/1/c3/1:1.1 {
        eth-ring 1
      }
    }
  }
}

```

SAPs or SDPs can be added to a control channel VPLS on condition the **eth-ring** parameter is present. Any attempt to add a SAP without the **eth-ring** parameter to a control channel VPLS results in the following messages being displayed.

```

*[ex:/configure service vpls "control-VPLS-1" sap 1/1/c4/1:1]
A:admin@PE-1# commit
MINOR: SVCMgr #2590: configure service vpls "control-VPLS-1" sap 1/1/c3/1:1.1 - Invalid
Ethernet ring configuration - Ring control SAP cannot be added to service that contains non-
ring SAPs or SDP bindings - configure service vpls "control-VPLS-1" sap 1/1/c3/1:1.1 eth-ring
MINOR: SVCMgr #2590: configure service vpls "control-VPLS-1" sap 1/1/c3/1:1.1 - Invalid
Ethernet ring configuration - Ethernet Ring Control service should only have controls saps
from same ring - configure service vpls "control-VPLS-1" sap 1/1/c3/1:1.1 eth-ring
MINOR: SVCMgr #2590: configure service vpls "control-VPLS-1" sap 1/1/c1/1:1.1 - Invalid
Ethernet ring configuration - Ring control SAP cannot be added to service that contains non-
ring SAPs or SDP bindings - configure service vpls "control-VPLS-1" sap 1/1/c1/1:1.1 eth-ring
MINOR: SVCMgr #2590: configure service vpls "control-VPLS-1" sap 1/1/c1/1:1.1 - Invalid
Ethernet ring configuration - Ethernet Ring Control service should only have controls saps
from same ring - configure service vpls "control-VPLS-1" sap 1/1/c1/1:1.1 eth-ring

```

For the subring, the configuration of a split horizon group for the virtual channel on the major ring on the interconnection nodes is recommended. This avoids the looping of control R-APS messages in the case there is a misconfiguration in the major ring.

On ring node PE-1, the control service for the subring "control-VPLS-2" is configured as follows. SAP 1/1/c1/1:2.1 and SAP 1/1/c3/1:2.1 connect to the major ring (ring 1) for the virtual channel, whereas SAP 1/1/c2/1:2.1 connects to the subring (ring 2).

```

# on PE-1:
configure {
  service {
    vpls "control-VPLS-2" {
      admin-state enable
      description "Control/virtual channel VID 2.1 for ring 2"
      service-id 2
      customer "1"
      split-horizon-group "shg-ring2" {
      }
      sap 1/1/c1/1:2.1 {
        description "ring 2 interconnection using ring 1"
        eth-ring 1
        split-horizon-group "shg-ring2"
      }
    }
  }
}

```

```

    sap 1/1/c2/1:2.1 {
      eth-ring 2
    }
    sap 1/1/c3/1:2.1 {
      description "ring 2 interconnection using ring 1"
      eth-ring 1
      split-horizon-group "shg-ring2"
    }
  }

```

On ring node PE-2, subring 2 is not present. However, the control service "control-VPLS-2" for the subring must be configured on PE-2, because the virtual channel for subring 2 needs to exist throughout major ring 1.

```

# on PE-2:
configure {
  service {
    vpls "control-VPLS-2" {
      admin-state enable
      description "virtual channel VID 2.1 for ring 2"
      service-id 2
      customer "1"
      sap 1/1/c1/1:2.1 {
        eth-ring 1
      }
      sap 1/1/c2/1:2.1 {
        eth-ring 1
      }
    }
  }
}

```

If multiple virtual channels are used (due to the aggregation of multiple subrings into the same major ring), their configuration could be simplified on non-interconnection nodes on the major ring. To achieve this on a ring node such as PE-2, a default SAP could be used rather than configuring a VPLS per virtual channel. If QinQ SAPs are used then default SAPs 1/1/c1/1:qtag.\* and 1/1/c2/1:qtag.\* could be used but this requires all control channels for subrings to be using qtag as the outer VLAN ID, or 1/1/c1/1:\* and 1/1/c2/1:\* if dot1Q SAPs were used. This is because the SAPs match explicit SAP definitions first and the default SAP will handle any other traffic.

The following configuration for control service "control-VPLS-2" for the subring on ring node PE-3 is similar to the configuration of PE-1.

```

# on PE-3:
configure {
  service {
    vpls "control-VPLS-2" {
      admin-state enable
      description "control/virtual channel VID 2.1 for ring 2"
      service-id 2
      customer "1"
      split-horizon-group "shg-ring2" {
      }
      sap 1/1/c1/1:2.1 {
        eth-ring 2
      }
      sap 1/1/c2/1:2.1 {
        description "ring 2 interconnection using ring 1"
        eth-ring 1
        split-horizon-group "shg-ring2"
      }
      sap 1/1/c3/1:2.1 {
        description "ring 2 interconnection using ring 1"
      }
    }
  }
}

```

```

    eth-ring 1
      split-horizon-group "shg-ring2"
    }
  }

```

On ring node PE-4, control service "control-VPLS-2" for the subring is configured as follows. Both SAPs are configured on the subring (ring 2).

```

# on PE-4:
configure {
  service {
    vpls "control-VPLS-2" {
      admin-state enable
      description "control VID 2.1 for subring 2"
      service-id 2
      customer "1"
      sap 1/1/c1/1:2.1 {
        eth-ring 2
      }
      sap 1/1/c2/1:2.1 {
        eth-ring 2
      }
    }
  }
}

```

At this point, the Ethernet ring 1 is operationally up and the RPL is blocking successfully RPL end port 1/1/c1/1 on RPL owner PE-2 and RPL end port 1/1/c2/1 on RPL neighbor PE-3.

## Show output

An overview of all of the rings can be shown using the following commands, in this case on PE-1.

The following command shows the Ethernet ring status on PE-1.

```

[/]
A:admin@PE-1# show eth-ring status
=====
Ethernet Ring (Status information)
=====
Ring  Admin  Oper   Path Information          MEP Information
ID    State  State Path          Tag      State    Ctrl-MEP CC-Intvl Defects
-----
1     Up     Up     a - 1/1/c1/1    1.1    Up      Yes     1     -----
      b - 1/1/c3/1    1.1    Up      Yes     1     -----
2     Up     Up     a - 1/1/c2/1    2.1    Up      Yes     1     -----
      b - N/A          -      -       -       -     -----
=====
Ethernet Tunnel MEP Defect Legend:
R = Rdi, M = MacStatus, C = RemoteCCM, E = ErrorCCM, X = XconCCM

```

It is expected that the state is "up", even on ring paths which are blocked. The "Defects" column refers to the CFM defects of the MEPs. If there is a problem, these will be flagged.

The following command shows the ring and path forwarding states on PE-1.

```

[/]
A:admin@PE-1# show eth-ring
=====

```

```

Ethernet Rings (summary)
=====
Ring Int  Admin Oper          Paths Summary          Path States
ID  ID  State State                a - b -                a      b
-----
1   -   Up   Up   a - 1/1/c1/1   1.1 b - 1/1/c3/1   1.1  U   U
2   1   Up   Up   a - 1/1/c2/1   2.1 b - Not configured  U   -
=====
Ethernet Ring Summary Legend:  B - Blocked    U - Unblocked
  
```

The following command shows specific information for major ring 1 on ring node PE-1:

```

[/]
A:admin@PE-1# show eth-ring 1

=====
Ethernet Ring 1 Information
=====
Description          : Ethernet ring 1_major ring
Admin State          : Up                Oper State          : Up
Node ID              : 02:09:ff:00:00:00
Guard Time           : 5 deciseconds   RPL Node            : rplNone
Max Revert Time      : 60 seconds       Time to Revert      : N/A
CCM Hold Down Time   : 0 centiseconds  CCM Hold Up Time    : 20 deciseconds
Compatible Version    : 2
APS Tx PDU           : N/A
Defect Status         :

Sub-Ring Type        : none

-----
Ethernet Ring Path Summary
-----
Path Port           Raps-Tag   Admin/Oper      Type           Fwd State
-----
a 1/1/c1/1          1.1        Up/Up           normal         unblocked
b 1/1/c3/1          1.1        Up/Up           normal         unblocked
=====
  
```

The status around the major ring can also be checked.

The following command shows specific information for major ring 1 on RPL owner PE-2:

```

[/]
A:admin@PE-2# show eth-ring 1

=====
Ethernet Ring 1 Information
=====
Description          : Ethernet ring 1_major ring
Admin State          : Up                Oper State          : Up
Node ID              : 02:0b:ff:00:00:00
Guard Time           : 5 deciseconds   RPL Node            : rplOwner
Max Revert Time      : 60 seconds       Time to Revert      : N/A
CCM Hold Down Time   : 0 centiseconds  CCM Hold Up Time    : 20 deciseconds
Compatible Version    : 2
APS Tx PDU           : Request State: 0x0
                       Sub-Code          : 0x0
                       Status           : 0x80 ( RB )
                       Node ID          : 02:0b:ff:00:00:00
Defect Status         :

Sub-Ring Type        : none
  
```

```
-----
Ethernet Ring Path Summary
-----
Path Port          Raps-Tag    Admin/Oper  Type        Fwd State
-----
a 1/1/c1/1         1.1        Up/Up       rplEnd     blocked
b 1/1/c2/1         1.1        Up/Up       normal      unblocked
=====
```

PE-2 is the RPL owner with port 1/1/c1/1 as an RPL end, which is blocked as expected. The revert time is also shown to be the configured value of 60 seconds. Detailed information is shown relating to the R-APS PDUs being transmitted on this ring because PE-2 is the RPL owner.

When a revert is pending after a link failure has been removed, the "Time to Revert" will show the number of seconds remaining before the revert occurs.

The following command shows specific information for major ring 1 on RPL neighbor PE-3:

```
[/]
A:admin@PE-3# show eth-ring 1

=====
Ethernet Ring 1 Information
=====
Description      : Ethernet ring 1_major ring
Admin State      : Up
Oper State       : Up
Node ID          : 02:0d:ff:00:00:00
Guard Time      : 5 deciseconds
Max Revert Time  : 60 seconds
CCM Hold Down Time : 0 centiseconds
Compatible Version : 2
APS Tx PDU       : N/A
Defect Status    :

Sub-Ring Type    : none

-----
Ethernet Ring Path Summary
-----
Path Port          Raps-Tag    Admin/Oper  Type        Fwd State
-----
a 1/1/c3/1         1.1        Up/Up       normal      unblocked
b 1/1/c2/1         1.1        Up/Up       rplEnd     blocked
=====
```

PE-3 is the RPL neighbor with port 1/1/c2/1 as an RPL end which is blocked as expected.

The information for the subring can also be shown using a similar command. The following command shows specific information for subring 2 on ring node PE-1:

```
[/]
A:admin@PE-1# show eth-ring 2

=====
Ethernet Ring 2 Information
=====
Description      : Ethernet subring 2 on major ring 1
Admin State      : Up
Oper State       : Up
Node ID          : 02:09:ff:00:00:00
Guard Time      : 5 deciseconds
Max Revert Time  : 60 seconds
RPL Node        : rplNone
Time to Revert   : N/A
```

```
CCM Hold Down Time : 0 centiseconds CCM Hold Up Time : 20 deciseconds
Compatible Version : 2
APS Tx PDU : N/A
Defect Status :

Sub-Ring Type : virtualLink Interconnect-ID : 1
Topology Change : Propagate
```

-----  
 Ethernet Ring Path Summary  
 -----

Path	Port	Raps-Tag	Admin/Oper	Type	Fwd State
a	1/1/c2/1	2.1	Up/Up	normal	unblocked
b	-	-	-/-	-	-

=====

Only path "a" is active and unblocked. Path "b" is not configured because only one path is required on an interconnection node. The "Sub-Ring Type" is shown to be a virtual link interconnecting to ring 1, with topology propagation enabled.

The following command shows specific information for subring 2 on ring node PE-3:

```
[/]
A:admin@PE-3# show eth-ring 2

=====
Ethernet Ring 2 Information
=====
Description      : Ethernet subring 2 on major ring 1
Admin State     : Up
Oper State      : Up
Node ID         : 02:0d:ff:00:00:00
Guard Time      : 5 deciseconds
Max Revert Time : 60 seconds
CCM Hold Down Time : 0 centiseconds CCM Hold Up Time : 20 deciseconds
Compatible Version : 2
APS Tx PDU      : N/A
Defect Status    :

Sub-Ring Type : virtualLink Interconnect-ID : 1
Topology Change : Propagate
```

-----  
 Ethernet Ring Path Summary  
 -----

Path	Port	Raps-Tag	Admin/Oper	Type	Fwd State
a	1/1/c1/1	2.1	Up/Up	rplEnd	blocked
b	-	-	-/-	-	-

=====

PE-3 is the RPL neighbor with port 1/1/c1/1 as an RPL end, which is blocked as expected.

The following command shows specific information for subring 2 on ring node PE-4:

```
[/]
A:admin@PE-4# show eth-ring 2

=====
Ethernet Ring 2 Information
=====
Description      : Ethernet subring 2
Admin State     : Up
Oper State      : Up
```



```

Node ID       : 02:0f:ff:00:00:00
Guard Time   : 5 deciseconds   RPL Node       : rplOwner
Max Revert Time : 60 seconds     Time to Revert  : N/A
CCM Hold Down Time : 0 centiseconds CCM Hold Up Time : 20 deciseconds
Compatible Version : 2
APS Tx PDU    : Request State: 0x0
                Sub-Code       : 0x0
                Status         : 0xE0 ( RB DNF BPR )
                Node ID        : 02:0f:ff:00:00:00

Defect Status :

Sub-Ring Type : none
  
```

-----  
 Ethernet Ring Path Summary  
 -----

Path	Port	Raps-Tag	Admin/Oper	Type	Fwd State
a	1/1/c1/1	2.1	Up/Up	normal	unblocked
b	1/1/c2/1	2.1	Up/Up	<b>rplEnd</b>	<b>blocked</b>

=====

PE-4 is the RPL owner with port 1/1/c2/1 as an RPL end, which is blocked as expected.  
 The following command shows the details of an individual path.

```

[/]
A:admin@PE-1# show eth-ring 1 path a

=====
Ethernet Ring 1 Path Information
=====
Description       : Ethernet ring 1_path a
Port              : 1/1/c1/1           Raps-Tag         : 1.1
Admin State      : Up                 Oper State       : Up
Path Type        : normal              Fwd State        : unblocked
                                           Fwd State Change : 05/16/2023 08:14:44

Last Switch Command: noCmd
APS Rx PDU       : Request State: 0x0
                  Sub-Code       : 0x0
                  Status         : 0x80 ( RB )
                  Node ID        : 02:0b:ff:00:00:00

=====
  
```

The ring hierarchy created can be shown, either for all rings, or as follows for a specific ring.

```

[/]
A:admin@PE-1# show eth-ring 1 hierarchy

=====
Ethernet Ring 1 (hierarchy)
=====
Ring Int  Admin Oper          Paths Summary          Path States
ID  ID    State State                a      b
-----
1    -    Up    Up    a - 1/1/c1/1    1.1  b - 1/1/c3/1    1.1  U    U
2    1    Up    Up    a - 1/1/c2/1    2.1  b - Not configured  U    -

Ethernet Ring Summary Legend:  B - Blocked  U - Unblocked
  
```

## Configure the user data channel VPLS service

The user data channels are created on a separate VPLS, "VPLS-11" in this example, using VLAN tag 1.11. The ring data channels must be on the same ports as the corresponding control channels configured above. The access into the data services can use normal SAPs or SDPs, for example the SAP on port 1/1/c4/1 in the following output. Customer data traverses the ring on a data SAP. Multiple parallel data SAPs in different data services can be controlled by one control ring instance, Ethernet ring 1 in the example.

Data VPLS "VPLS-11" on ring node PE-1 has data SAPs 1/1/c1/1:1.11 and 1/1/c3/1:1.11 on major ring 1, while SAP 1/1/c2/1:1.11 is the data SAP on subring 2.

```
# on PE-1:
configure {
  service {
    vpls "VPLS-11" {
      admin-state enable
      description "data VPLS"
      service-id 11
      customer "1"
      sap 1/1/c1/1:1.11 {
        eth-ring 1
      }
      sap 1/1/c2/1:1.11 {
        eth-ring 2
      }
      sap 1/1/c3/1:1.11 {
        eth-ring 1
      }
      sap 1/1/c4/1:11 {
        description "sample customer service SAP"
      }
    }
  }
}
```

The configuration of data VPLS "VPLS-11" on ring node PE-3 (not shown) is similar to ring node PE-1.

The configuration of data VPLS "VPLS-11" on ring node PE-2 has data SAPs 1/1/c1/1:1.11 and 1/1/c3/1:1.11 on major ring 1.

```
# on PE-2:
configure {
  service {
    vpls "VPLS-11" {
      admin-state enable
      description "data VPLS"
      service-id 11
      customer "1"
      sap 1/1/c1/1:1.11 {
        eth-ring 1
      }
      sap 1/1/c2/1:1.11 {
        eth-ring 1
      }
      sap 1/1/c4/1:11 {
        description "sample customer service SAP"
      }
    }
  }
}
```

The configuration of data VPLS "VPLS-11" on ring node PE-4 has data SAPs 1/1/c1/1:1.11 and 1/1/c3/1:1.11 on subring 2.

```
# on PE-4:
configure {
  service {
    vpls "VPLS-11" {
      admin-state enable
      description "data VPLS"
      service-id 11
      customer "1"
      sap 1/1/c1/1:1.11 {
        eth-ring 2
      }
      sap 1/1/c2/1:1.11 {
        eth-ring 2
      }
      sap 1/1/c4/1:11 {
        description "sample customer service SAP"
      }
    }
  }
}
```

All the SAPs which are configured to use Ethernet rings can be displayed. The following output is taken from PE-1, where there are:

- two SAPs in VPLS 1 for the control channel of ring 1 (VLAN ID 1.1)
- two SAPs in VPLS 2 on ring 1 for the virtual channel for ring 2 (VLAN ID 2.1)
- one SAP in VPLS 2 on ring 2 for the control channel for ring 2 (VLAN ID 2.1)
- three SAPs in VPLS 11, two on ring 1 and one on ring 2, for the data service (VLAN ID 1.11). This matches the information in [Figure 7: G.8032 subring interconnection components](#).

```
[/]
A:admin@PE-1# show service sap-using eth-ring

=====
Service Access Points (Ethernet Ring)
=====
```

SapId	SvcId	Eth-Ring	Path	Admin State	Oper State	Blocked	Control/Data
1/1/c1/1:1.1	1	1	a	Up	Up	No	Ctrl
1/1/c3/1:1.1	1	1	b	Up	Up	No	Ctrl
1/1/c1/1:2.1	2	1	a	Up	Up	No	Ctrl
1/1/c2/1:2.1	2	2	a	Up	Up	No	Ctrl
1/1/c3/1:2.1	2	1	b	Up	Up	No	Ctrl
1/1/c1/1:1.11	11	1	a	Up	Up	No	Data
1/1/c2/1:1.11	11	2	a	Up	Up	No	Data
1/1/c3/1:1.11	11	1	b	Up	Up	No	Data

```
-----
Number of SAPs : 8
=====
```

Statistics are available showing both the CCM and R-APS messages sent and received on a node. An associated **clear** command is available.

```
[/]
A:admin@PE-1# show eth-cfm statistics

=====
```



"Eth-Ring 1 path b changed fwd state to blocked"

70 2023/05/16 08:43:36.640 CEST WARNING: SNMP #2004 Base 1/1/c2/1  
 "Interface 1/1/c2/1 is not operational"

For troubleshooting, the **tools dump eth-ring <ring-index>** command displays path information, the internal state of the control protocol, related statistics information, and up to the last 16 protocol events (including messages sent and received, and the expiration of timers). An associated **clear** parameter exists, which clears the event information in this output when the command is entered. The following is an example of the output on PE-2 after port 1/1/c2/1 has been enabled.

```
[/]
A:admin@PE-2# tools dump eth-ring 1

ringId 1 (Up/Up): numPaths 2 nodeId 02:0b:ff:00:00:00
SubRing: none (interconnect ring 0, propagateTc No), Cnt 0
path-a, port 1/1/c1/1 (Up), tag 1.1(Up) status (Up/Up/Blk)
  cc (Dn/Up): Cnt 1/1 tm 000 00:25:53.470/000 00:36:36.970
  state: Cnt 7 B/F 000 01:10:19.470/000 01:05:31.920, flag: 0x0
path-b, port 1/1/c2/1 (Up), tag 1.1(Up) status (Up/Up/Fwd)
  cc (Dn/Up): Cnt 2/2 tm 000 01:05:35.480/000 01:09:02.180
  state: Cnt 4 B/F 000 01:05:31.920/000 01:10:19.470, flag: 0x0
FsmState= IDLE, Rpl = Owner, revert = 60 s, guard = 5 ds
Defects =
Running Timers = PduReTx
lastTxPdu = 0x0080 Nr(RB )
path-a Rpl, RxId(I)= 02:09:ff:00:00:00, rx(F)= v1-0x0000 Nr, cmd= None
path-b Normal, RxId(I)= 02:09:ff:00:00:00, rx(F)= v1-0x0000 Nr, cmd= None
DebugInfo: aPathSts 3, bPathSts 3, pm (set/c1r) 0/0, txFlush 0
RxRaps: ok 9 nok 0 self 36, TmrExp - wtr 2(1), grd 2, wtb 0
Flush: cnt 8 (6/1/1) tm 000 01:10:19.470-000 01:10:19.470 Out/Ack 0/1
RxRawRaps: aPath 85 bPath 45 vPath 0
Now: 000 01:20:37.210 , softReset: No - noTx 0

Seq Event      RxInfo(Path: NodeId-Bytes)
state:TxInfo (Bytes)      Dir  pA  pB      Time
==== =====
001 bAdd
002 aUp          PROT : 0xb020 Sf          TxF-> Blk Blk 000 00:25:49.470
003 aDn          PROT : 0xb060 Sf(DNF)    Tx--> Fwd Blk 000 00:25:49.470
004 pdu B: 02:09:ff:00:00:00-0xb040 Sf(DNF)
PROT : 0xb000 Sf          TxF-> Blk Blk 000 00:25:53.470
005 pdu B: 02:09:ff:00:00:00-0x0000 Nr
PROT : 0xb000 Sf          Rx<-- Blk Blk 000 00:36:38.180
006 pdu A: 02:0d:ff:00:00:00-0x0020 Nr
PROT : 0xb000 Sf          Rx<-- Blk Blk 000 00:36:38.960
007 pdu B: 02:0d:ff:00:00:00-0x0020 Nr
PROT : 0xb000 Sf          Rx<-- Blk Blk 000 00:36:39.160
008 bUp          PROT : 0xb040 Sf(DNF)    Tx--> Blk Fwd 000 00:36:39.170
009 aUp          PEND-G: 0x0000 Nr        Tx--> Blk Fwd 000 00:36:39.470
010 pdu B: 02:09:ff:00:00:00-0xe000 Ev
PEND : 0x0000 Nr          Frx<- Blk Fwd 000 00:36:40.430
011 pdu A: 02:0d:ff:00:00:00-0x0020 Nr
PEND : 0x0000 Nr          Rx<-- Blk Fwd 000 00:36:40.440
012 pdu          PEND :
----- Fwd Fwd 000 00:36:40.440
013 pdu B: 02:0d:ff:00:00:00-0x0020 Nr
```

```

014 xWtr      PEND :                               Rx<-- Fwd Fwd 000 00:36:40.440
              IDLE : 0x0080 Nr(RB )              TxF-> Blk Fwd 000 00:37:40.470
015 bDn      PROT : 0xb020 Sf                    TxF-> Fwd Blk 000 01:05:31.920
016 pdu A: 02:09:ff:00:00:00-0xb000 Sf          RxF<- Fwd Blk 000 01:05:35.190
              PROT : 0xb020 Sf
017 pdu B: 02:09:ff:00:00:00-0x0000 Nr          Rx<-- Fwd Blk 000 01:09:03.480
              PROT : 0xb020 Sf
018 pdu A: 02:09:ff:00:00:00-0x0000 Nr          Rx<-- Fwd Blk 000 01:09:03.490
              PROT : 0xb020 Sf
019 bUp      PEND-G: 0x0020 Nr                   Tx--> Fwd Blk 000 01:09:04.170
000 xWtr      IDLE : 0x0080 Nr(RB )              TxF-> Blk Fwd 000 01:10:19.470
  
```

### Configuration of a subring to a major ring with a non-virtual link

The differences from the preceding virtual link configuration with a non-virtual link for the subring are:

- The subring configuration on the interconnection nodes, PE-1 and PE-3, is modified to indicate that the subring is not using a virtual link, otherwise it remains the same.
- The subring configuration on the subring node PE-4 is also modified to indicate that this is part of a subring that is not using a virtual link. This is mandatory on all non-interconnection nodes on the subring in order to ensure the propagation of R-APS messages around the subring.
- The virtual link services and SAPs must be removed from PE-1, PE-2, and PE3, that is:
  - On PE-1 and PE-3, the SAPs in VPLS 2 around the major ring (configured with the parameter **eth-ring 1**) are removed.
  - The service "control-VPLS-2" is removed completely from PE-2.

The new configuration of subring 2 on PE-1 is as follows, the configuration on PE-3 is similar.

```

# on PE-1:
configure {
  eth-ring 2 {
    admin-state enable
    description "Ethernet subring 2 on major ring 1"
    revert-time 60
    sub-ring {
      type non-virtual-link
      interconnect {
        ring-id 1
        propagate-topology-change true
      }
    }
    path "a" {
      admin-state enable
      description "Ethernet subring 2_path a"
      port-and-raps-tag 1/1/c2/1:2.1
      eth-cfm {
        mep md-admin-name "domain-1" ma-admin-name "association-14" mep-id 141 {
          admin-state enable
          ccm true
          control-mep true
        }
      }
    }
  }
}
  
```

The configuration of subring 2 on non-interconnection node PE-4 must include the **type non-virtual-link** parameter, as follows:

```
# on PE-4:
configure {
  eth-ring 2 {
    admin-state enable
    description "Ethernet subring 2"
    revert-time 60
    rpl-node owner
    sub-ring {
      type non-virtual-link
    }
    path "a" {
      admin-state enable
      description "Ethernet subring 2_path a"
      port-and-raps-tag 1/1/c1/1:2.1
      eth-cfm {
        mep md-admin-name "domain-1" ma-admin-name "association-14" mep-id 144 {
          admin-state enable
          ccm true
          control-mep true
        }
      }
    }
    path "b" {
      admin-state enable
      description "Ethernet subring 2_path b"
      port-and-raps-tag 1/1/c2/1:2.1
      rpl-end true
      eth-cfm {
        mep md-admin-name "domain-1" ma-admin-name "association-34" mep-id 344 {
          admin-state enable
          ccm true
          control-mep true
        }
      }
    }
  }
}
```

The SAP usage on PE-1 is as follows with only the control and data SAPs to PE-4 now using subring 2.

```
[/]
A:admin@PE-1# show service sap-using eth-ring

=====
Service Access Points (Ethernet Ring)
=====
```

SapId	SvcId	Eth-Ring	Path	Admin State	Oper State	Blocked	Control/Data
1/1/c1/1:1.1	1	1	a	Up	Up	No	Ctrl
1/1/c3/1:1.1	1	1	b	Up	Up	No	Ctrl
1/1/c2/1:2.1	2	2	a	Up	Up	No	Ctrl
1/1/c1/1:1.11	11	1	a	Up	Up	No	Data
1/1/c2/1:1.11	11	2	a	Up	Up	No	Data
1/1/c3/1:1.11	11	1	b	Up	Up	No	Data

```
-----
Number of SAPs : 6
=====
```

The information relating to subring 2 is as follows and it can be seen that this is now not using a virtual link, but subring 2 is still connected to major ring 1 and propagation is still enabled from the subring to the major ring. The single ring path "a" is unblocked because the RPL is configured between PE-3 and PE-4.

```
[/]
A:admin@PE-1# show eth-ring 2

=====
Ethernet Ring 2 Information
=====
Description      : Ethernet subring 2 on major ring 1
Admin State      : Up                               Oper State      : Up
Node ID          : 02:09:ff:00:00:00
Guard Time       : 5 deciseconds                    RPL Node        : rplNone
Max Revert Time  : 60 seconds                        Time to Revert   : N/A
CCM Hold Down Time : 0 centiseconds                  CCM Hold Up Time : 20 deciseconds
Compatible Version : 2
APS Tx PDU       : N/A
Defect Status     :

Sub-Ring Type    : nonVirtualLink                    Interconnect-ID : 1
Topology Change  : Propagate

-----
Ethernet Ring Path Summary
-----
Path Port      Raps-Tag   Admin/Oper   Type        Fwd State
-----
a 1/1/c2/1     2.1         Up/Up        normal      unblocked
b -            -           -/-         -           -
=====
```

### Configuration of a subring to a VPLS service

Subrings can be connected to VPLS services, in which case a virtual link is not used and is not configurable. While similar to the ring interconnect, there are a few differences.

Flush propagation is from the subring to the VPLS, in the same way as it was for the subring to the major ring. The same configuration parameter is used to propagate topology changes. In this case, LDP "flush-all-from-me" messages are sent into the LDP portion of the network to account for ring changes without the need to configure anything in the VPLS service.

As with other rings, until an Ethernet ring instance is attached to the VPLS service, the ring operational status is down and the forwarding status of each port is blocked. This prevents operators from creating a loop by misconfiguration.

The topology for this case is shown in [Figure 10: Subring to VPLS topology](#). The configuration is very similar to the subring with a non-virtual link described earlier, but ring 1 is replaced by a VPLS service using LDP-signaled mesh SDPs between PE-1, PE-2, and PE-3 to create a fully meshed VPLS service. Both spoke and mesh SDPs using LDP can be used for the VPLS; however, only mesh SDPs have been used in this example.



Figure 10: Subring to VPLS topology

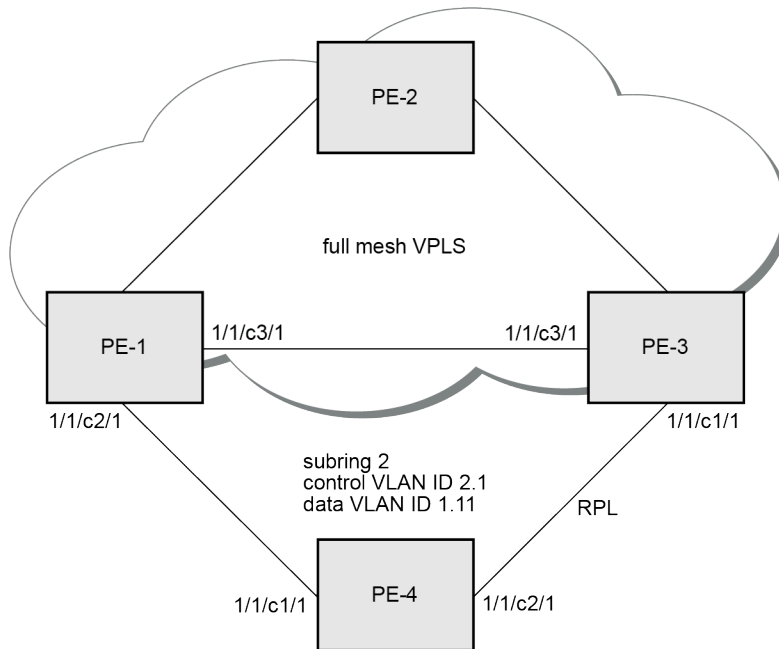

al\_0534

The differences for the VPLS service connection to the configuration when the subring is connected to a major ring without a virtual link are:

- The subring configuration on the interconnection nodes, PE-1 and PE-3, is modified to indicate that the subring is connected to a VPLS service.
- The subring configuration on the non-interconnection node PE-4 indicates that this is part of a subring that is not using a virtual link (same configuration as in the scenario when a subring is connected to a major ring without a virtual link). This is mandatory on all non-interconnection nodes on the subring in order to ensure the propagation of R-APS messages around the subring.
- The control VPLS "control-VPLS-1" and SAPs relating to the major ring 1 on PE-1, PE-2, and PE-3 are removed. These are replaced by routed IP interfaces configured with a routing protocol and LDP in order to signal the required MPLS labels, together with the necessary SDPs to provide interconnection at a service level.
- The data service "VPLS-11" is configured with mesh SDPs between PE-1, PE-2, and PE-3.

The configuration on PE-1 of the subring 2 is as follows with the interconnect indicating a VPLS service. The configuration on PE-3 is similar.

```
# on PE-1:
configure {
  eth-ring 2 {
    admin-state enable
    description "Ethernet subring 2 on VPLS"
    revert-time 60
    sub-ring {
      type non-virtual-link
      interconnect {
        vpls
        propagate-topology-change true
      }
    }
  }
}
```

```

}
path "a" {
  admin-state enable
  description "Ethernet subring 2_path a"
  port-and-raps-tag 1/1/c2/1:2.1
  eth-cfm {
    mep md-admin-name "domain-1" ma-admin-name "association-14" mep-id 141 {
      admin-state enable
      ccm true
      control-mep true
    }
  }
}
}

```

The following configuration of subring 2 on non-interconnection node PE-4 includes the **type non-virtual-link** parameter:

```

# on PE-4:
configure {
  eth-ring 2 {
    admin-state enable
    description "Ethernet subring 2"
    revert-time 60
    rpl-node owner
    sub-ring {
      type non-virtual-link
    }
    path "a" {
      admin-state enable
      description "Ethernet subring 2_path a"
      port-and-raps-tag 1/1/c1/1:2.1
      eth-cfm {
        mep md-admin-name "domain-1" ma-admin-name "association-14" mep-id 144 {
          admin-state enable
          ccm true
          control-mep true
        }
      }
    }
    path "b" {
      admin-state enable
      description "Ethernet subring 2_path b"
      port-and-raps-tag 1/1/c2/1:2.1
      rpl-end true
      eth-cfm {
        mep md-admin-name "domain-1" ma-admin-name "association-34" mep-id 344 {
          admin-state enable
          ccm true
          control-mep true
        }
      }
    }
  }
}
}

```

The data service on PE-1 is as follows. The configuration on PE-3 is similar.

```

# on PE-1:
configure {
  service {
    vpls "VPLS-11" {
      admin-state enable
      description "data VPLS"
      service-id 11
    }
  }
}

```

```

customer "1"
mesh-sdp 12:11 {
}
mesh-sdp 13:11 {
}
sap 1/1/c2/1:1.11 {
  eth-ring 2
}
sap 1/1/c4/1:11 {
  description "sample customer service SAP"
}
  
```

The state of the subring is as follows and shows the subring is not using a virtual link, is connected to a VPLS service, and has propagation of topology change events enabled. As earlier, the single ring path "a" is unblocked because the RPL is configured between PE-3 and PE-4.

```

[/]
A:admin@PE-1# show eth-ring 2
=====
Ethernet Ring 2 Information
=====
Description      : Ethernet subring 2 on VPLS
Admin State      : Up
Oper State       : Up
Node ID          : 02:09:ff:00:00:00
Guard Time       : 5 deciseconds
RPL Node         : rplNone
Max Revert Time  : 60 seconds
Time to Revert   : N/A
CCM Hold Down Time : 0 centiseconds
CCM Hold Up Time : 20 deciseconds
Compatible Version : 2
APS Tx PDU       : N/A
Defect Status    :

Sub-Ring Type      : nonVirtualLink
Interconnect-ID   : VPLS
Topology Change   : Propagate

-----
Ethernet Ring Path Summary
-----
Path Port      Raps-Tag  Admin/Oper  Type      Fwd State
-----
a 1/1/c2/1     2.1       Up/Up       normal    unblocked
b -            -         -/-        -         -
=====
  
```

In this case, if a topology change event occurs in the subring, an LDP "flush-all-from-me" message is sent by PE-1 and PE-3 to their LDP peers. This can be seen by enabling the following debugging for PE-1:

```

# on PE-1:
debug {
  router "Base" {
    ldp {
      peer 192.0.2.2 {
        packet {
          init {
          }
        }
      }
      peer 192.0.2.3 {
        packet {
          init {
          }
        }
      }
    }
  }
}
  
```

```
}

```

The topology change is forced by disabling port 1/1/c2/1 on PE-1.

```
# on PE-1:
configure {
  port 1/1/c2/1
    admin-state disable

```

The log shows the following messages on the console (combination of log 1 for debug-trace and log 2 for main), where packets 1 and 2 are the LDP flush messages.

```
88 2023/05/16 09:39:27.293 CEST WARNING: SNMP #2004 Base 1/1/c2/1
"Interface 1/1/c2/1 is not operational"

89 2023/05/16 09:39:27.293 CEST MINOR: ERING #2001 Base eth-ring-2
"Eth-Ring 2 path a changed fwd state to blocked"

1 2023/05/16 09:39:27.294 CEST MINOR: DEBUG #2001 Base LDP
"LDP: LDP
Send Address Withdraw packet (msgId 191) to 192.0.2.2:0
MAC Flush (All MACs learned from me)
Service FEC PWE3: ENET(5)/11 Group ID = 0 cBit = 0
"

2 2023/05/16 09:39:27.294 CEST MINOR: DEBUG #2001 Base LDP
"LDP: LDP
Send Address Withdraw packet (msgId 190) to 192.0.2.3:0
MAC Flush (All MACs learned from me)
Service FEC PWE3: ENET(5)/11 Group ID = 0 cBit = 0
"

90 2023/05/16 09:39:27.299 CEST MAJOR: SVCMGR #2210 Base
"Processing of an access port state change event is finished and the status of a
ll affected SAPs on port 1/1/c2/1 has been updated."

91 2023/05/16 09:39:30.909 CEST MINOR: ETH_CFM #2001 Base
"MEP 1/14/141 highest defect is now defRemoteCCM"

```

## Operational procedures

Operators may wish to configure rings with or without control over reversion. Reversion can be controlled by timers or the ring can be run without reversion allowing the operator to choose when the ring reverts. To change a ring topology, the **manual** or **force** switch command may be used to block a specified ring path. A ring will still address failures when run without reversion but will not automatically revert to the RPL when resources are restored. A **clear** command can be used to clear the manual or force state of a ring.

The following **tools** commands are available to control the state of paths on a ring.

```
tools perform eth-ring clear <ring-index>
tools perform eth-ring force <ring-index> path {a|b}
tools perform eth-ring manual <ring-index> path {a|b}

```

In the following output, both ports of Ethernet ring 1 are unblocked.

```
[/]
A:admin@PE-1# show eth-ring 1

```

```

=====
Ethernet Ring 1 Information
=====
Description      : Ethernet ring 1_major ring
Admin State     : Up                Oper State      : Up
Node ID        : 02:09:ff:00:00:00
Guard Time     : 5 deciseconds    RPL Node       : rplNone
Max Revert Time : 60 seconds        Time to Revert  : N/A
CCM Hold Down Time : 0 centiseconds  CCM Hold Up Time : 20 deciseconds
Compatible Version : 2
APS Tx PDU     : N/A
Defect Status   :

Sub-Ring Type   : none

-----
Ethernet Ring Path Summary
-----
Path Port      Raps-Tag   Admin/Oper   Type        Fwd State
-----
a 1/1/c1/1    1.1        Up/Up        normal      unblocked
b 1/1/c3/1    1.1        Up/Up        normal      unblocked
=====
  
```

The following command blocks path "b" of Ethernet ring 1 manually:

```
*A:PE-1# tools perform eth-ring manual 1 path b
```

In the following output, path "b" of Ethernet ring 1 is blocked:

```

[/]
A:admin@PE-1# show eth-ring 1

=====
Ethernet Ring 1 Information
=====
Description      : Ethernet ring 1_major ring
Admin State     : Up                Oper State      : Up
Node ID        : 02:09:ff:00:00:00
Guard Time     : 5 deciseconds    RPL Node       : rplNone
Max Revert Time : 60 seconds        Time to Revert  : N/A
CCM Hold Down Time : 0 centiseconds  CCM Hold Up Time : 20 deciseconds
Compatible Version : 2
APS Tx PDU     : Request State: 0x7
                  Sub-Code   : 0x0
                  Status    : 0x20 ( BPR )
                  Node ID   : 02:09:ff:00:00:00
Defect Status   :

Sub-Ring Type   : none

-----
Ethernet Ring Path Summary
-----
Path Port      Raps-Tag   Admin/Oper   Type        Fwd State
-----
a 1/1/c1/1    1.1        Up/Up        normal      unblocked
b 1/1/c3/1    1.1        Up/Up        normal      blocked
=====
  
```

The following command on PE-1 clears Ethernet ring 1:

```
[/]
A:admin@PE-1# tools perform eth-ring clear 1
```

After Ethernet ring 1 is cleared on PE-1, both paths are unblocked again.

```
[/]
A:admin@PE-1# show eth-ring 1

=====
Ethernet Ring 1 Information
=====
Description      : Ethernet ring 1_major ring
Admin State      : Up                Oper State       : Up
Node ID          : 02:09:ff:00:00:00
Guard Time       : 5 deciseconds   RPL Node         : rplNone
Max Revert Time  : 60 seconds        Time to Revert   : N/A
CCM Hold Down Time : 0 centiseconds  CCM Hold Up Time : 20 deciseconds
Compatible Version : 2
APS Tx PDU       : N/A
Defect Status     :

Sub-Ring Type    : none

-----
Ethernet Ring Path Summary
-----
Path Port          Raps-Tag   Admin/Oper    Type          Fwd State
-----
a 1/1/c1/1         1.1        Up/Up         normal        unblocked
b 1/1/c3/1         1.1        Up/Up         normal        unblocked
=====
```

Both the **manual** and **force** command block the path specified, however, the **manual** command fails if there is an existing forced switch or signal fail event in the ring, as seen in the following output. The **force** command will block the port regardless of any existing ring state and there can be multiple force states simultaneously on a ring on different nodes.

```
[/]
A:admin@PE-1# tools perform eth-ring force 1 path b

[/]
A:admin@PE-1# tools perform eth-ring manual 1 path b
INFO: ERMGR #1001: Not permitted - The switch command is not compatible to the current state
(FS), effective priority (FS) or rpl-node type (None)
```

## Conclusion

Ethernet ring APS provides an optimal solution for designing native Ethernet services with ring topology. With subrings, both multiple rings and access rings increase the versatility of G.8032. G.8032 has been expanded to more of the SR platforms by allowing R-APS with slower MEPs (including CCMs intervals of 1 second). This protocol provides simple configuration, operation, and guaranteed fast protection time. The implementation also has a flexible encapsulation that allows dot1Q, QinQ, or PBB for the ring traffic. It can be utilized on various services such as mobile backhaul, business VPN access, aggregation, and core.

# G.8032 Ethernet Ring Protection Single Ring Topology

This chapter provides information about G.8032 Ethernet ring protection single ring topology.

Topics in this chapter include:

- [Applicability](#)
- [Overview](#)
- [Configuration](#)
- [Conclusion](#)

## Applicability

The chapter was initially written for SR OS Release 8.0.R7, but the MD-CLI in the current edition corresponds to SR OS Release 23.3.R2. This chapter describes ring protection for a single ring topology. Protection for multiple ring topologies is covered in [G.8032 Ethernet Ring Protection Multiple Ring Topology](#).

## Overview

G.8032 Ethernet ring protection is supported for data service SAPs within a regular VPLS service, a provider backbone bridging (PBB) VPLS (I/B-component), or a routed VPLS (R-VPLS). G.8032 is one of the fastest protection schemes for Ethernet networks.

ITU-T G.8032v2 specifies protection switching mechanisms and a protocol for Ethernet layer network (ETH) Ethernet rings. Ethernet rings can provide wide-area multi-point connectivity more economically due to their reduced number of links. The mechanisms and protocol defined in ITU-T G.8032v2 achieve highly reliable and stable protection and never form loops, which would negatively affect network operation and service availability. Each ring node is connected to adjacent nodes participating in the same ring using two independent paths, which use ring links that are configured on ports or link aggregation groups (LAGs). A ring link is bounded by two adjacent nodes and a port for a ring link is called a ring port. The minimum number of nodes on a ring is two.

The fundamentals of this ring protection switching architecture are:

- the principle of loop avoidance and
- the utilization of learning, forwarding, and address table mechanisms defined in the ITU-T G.8032v2 Ethernet flow forwarding function (ETH\_FF) (control plane).

Loop avoidance in the ring is achieved by guaranteeing that, at any time, traffic may flow on all but one of the ring links. This particular link is called the ring protection link (RPL) and under normal conditions this link is blocked, so it is not used for traffic. One designated node, the RPL owner, is responsible to block traffic over the one designated RPL. Under a ring failure condition, the RPL owner is responsible for unblocking the RPL, allowing the RPL to be used for traffic. The protocol ensures that even without an RPL owner defined, one link will be blocked and it operates as a *break before make protocol*, specifically the

protocol guarantees that no link is restored until a different link in the ring is blocked. The other side of the RPL is configured as an RPL neighbor. An RPL neighbor blocks traffic on the link.

The event of a ring link or ring node failure results in protection switching of the traffic. This is achieved under the control of the ETH\_FF functions on all ring nodes. A ring automatic protection switching (R-APS) protocol is used to coordinate the protection actions over the ring. The protection switching mechanisms and protocol supports a multi-ring/ladder network that consists of connected Ethernet rings, however, that is not covered in this chapter.

## Ring protection mechanism

The ring protection protocol is based on the following building blocks:

- ring status change on failure
  - idle → link failure → protection → recovery → idle
- ring control state changes
  - idle → protection → manual switch → forced switch → pending
- re-use existing ETH OAM
  - monitoring: Ethernet continuity check messages
  - failure notification: Y.1731 signal failure
- forwarding database MAC flush on ring status change
- ring protection link (RPL) defines blocked link in idle status

[Figure 11: G.8032 operation and topologies](#) shows a ring of six nodes, with the RPL owner on the top right. One link of the RPL owner is designated to be the RPL and will be blocked in order to prevent a loop. Schematics of the physical and logical topologies are also shown.

When an RPL owner and RPL end are configured, the associated link will be the RPL when the ring is fully operational and so be blocked by the RPL owner. If a different ring link fails, then the RPL will be unblocked by the RPL owner. When the failed link recovers, it will initially be blocked by one of its adjacent nodes. The adjacent node sends an R-APS message across the ring to indicate the error is cleared and after a configurable time, if reversion is enabled, the RPL will revert to being blocked with all other links unblocked. This ensures that the ring topology is predictable when fully operational.

If a specific RPL owner is not configured, then the last link to become active will be blocked and the ring will remain in this state until another link fails. However, this operation makes the selection of the blocked link non-deterministic.



Figure 11: G.8032 operation and topologies

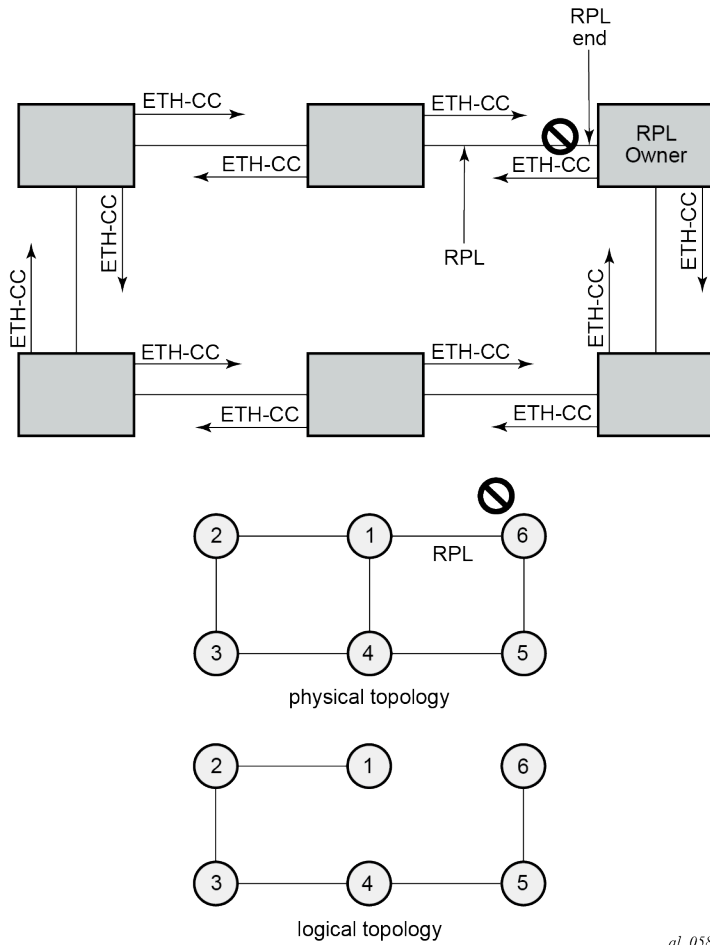

ai\_0588

The protection protocol uses a specific control VLAN, with the associated data VLANs taking their forwarding state from the control VLAN.

## Configuration

The example topology is shown in [Figure 12: Example topology](#).

Figure 12: Example topology

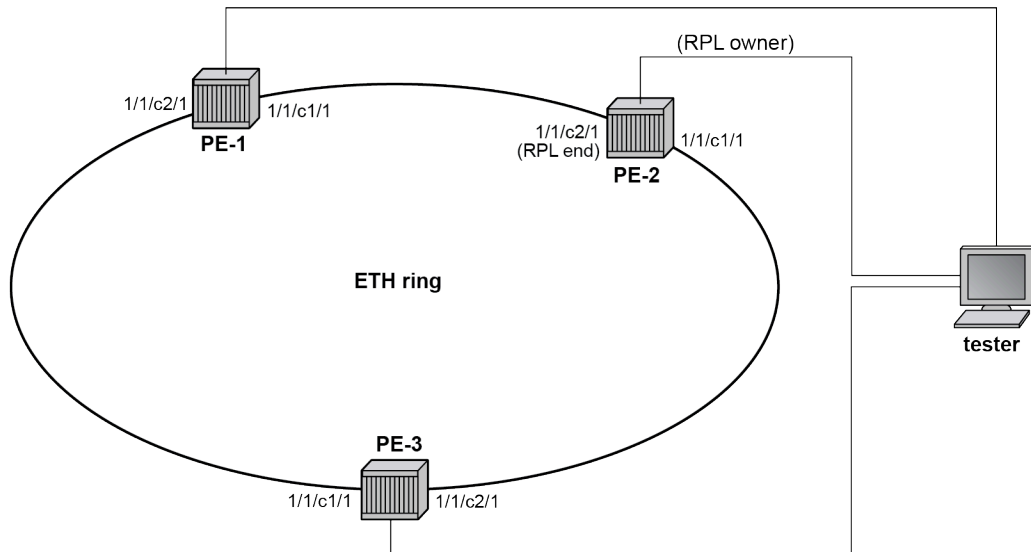

\*\* control channel: VPLS 1, tag 1  
 \*\* data channel: VPLS 100, tag 100

al\_0589

The Ethernet ring configuration commands are as follows:

```
configure {
  eth-ring <ring-index [1..128]> {
    ccm-hold-time {
      down <number> # Hold timer for down event dampening
      up <number> # Hold timer for recovery reporting
    }
    compatible-version <number> # [1..2] - Default: 2
    description <string>
    guard-time <number> # [1..20] in deciseconds - Default: 5
    node-id <mac-address> # MAC address of the RPL <xx:xx:xx:xx:xx:xx>
    path <string> # path ID: string of 1 character
    admin-state <keyword> # default: disable
    description <string>
    port-and-raps-tag <port-and-encap> # Port ID and Ring APS tag ID
    eth-cfm {
      mep md-admin-name <reference> ma-admin-name <reference> mep-id <number> {
        admin-state <keyword> # default: disable
        ccm <boolean> # default: false
        control-mep <boolean> # default: false
      }
    }
    rpl-end <boolean> # default: false
  }
  revert-time <number> # <0,60..720> in seconds - Default: 300
  rpl-node <keyword> # owner | neighbor
  sub-ring # beyond the scope
}
```

Parameters:

- *ring-index* — This is the number by which the ring is referenced, values: 1 to 128.

- **ccm-hold-time** **{[down <hold timer for down event dampening>] [up <hold timer for recovery reporting>]}**
  - **down** — This command specifies the timer that controls the delay between detecting that ring path is down and reporting it to the G.8032 protection module. If a non-zero value is configured, the system will wait for the time specified in the value parameter before reporting it to the G.8032 protection module. This parameter applies only to the ring path continuity check message (CCM); it does not apply to the ring port link state. To dampen ring port link state transitions, use the **hold-time** parameter from the physical member port. This is useful if the underlying path between two nodes is going across an optical system which implements its own protection.
  - **up** — This command specifies the timer which controls the delay between detecting that the ring path is up and reporting it to the G.8032 protection module. If a non-zero value is configured, the system will wait for the time specified in the value parameter before reporting it to the G.8032 protection module. This parameter applies only to ring path CCM; it does not apply to the member port link state. To dampen member port link state transitions, use the **hold-time** parameter from the physical member port.
  - hold timer values:

```
*[ex:/configure eth-ring 1 ccm-hold-time]
A:admin@PE-1# down ?

down <number>
<number> - <1..5000> - centiseconds

    Hold timer for down event dampening

*[ex:/configure eth-ring 1 ccm-hold-time]
A:admin@PE-1# up ?

up <number>
<number> - <0..5000> - deciseconds
Default - 20

    Hold timer for recovery reporting
```

- **compatible version** — This command configures the Ethernet ring compatibility version for the G.8032 state machine and messages. The default is version 2 (ITU G.8032v2) and all SR OS nodes use version 2. If there is a need to interwork with third party devices that only support version 1, this can be set to version 1 allowing the reception of version 1 PDUs. Version 2 is encoded as 1 in the R-APS messages. Compatibility allows the reception of version 1 (encoded as 0) R-APS PDUs but, as per the G.8032 specification, higher versions are ignored on reception. For SR OS nodes, messages are always originated with version 2. Therefore, if a third party switch supported version 3 (encoded as 2) or higher, interworking is also supported provided the other switch is compatible with version 2 (encoded as 1).
- **description <string>** — This configures a text string, up to 80 characters, which can be used to describe the use of the Ethernet ring.
- **guard-time <number>** — The forwarding method, in which R-APS messages are copied and forwarded at every Ethernet ring node, can result in a message corresponding to an old request, that is no longer relevant, being received by Ethernet ring nodes. Reception of an old R-APS message may result in erroneous ring state interpretation by some Ethernet ring nodes. The guard timer is used to prevent Ethernet ring nodes from acting upon outdated R-APS messages and prevents the possibility of forming a closed loop. Messages are not forwarded when the guard-timer is running.

The guard time is configured in 10ths of seconds and the default guard time is 0.5 s:

```
*[ex:/configure eth-ring 1]
A:admin@PE-1# guard-time ?

guard-time <number>
<number> - <1..20> - deciseconds
Default   - 5

Ethernet ring guard time
```

- **node-id <mac-address>** — The node identifier can be explicitly configured. In typical configurations, the node ID is not configured; by default, the chassis MAC address is used as node ID.
- **path [path-index] <1-character string> [port-and-raps-tag]** — The **path** parameter defines the paths around the ring, of which there are two in different directions on the ring: an "a" path and a "b" path. In addition, the path command configures the encapsulation used for the R-APS messages on the ring. These can be either single or double tagged.
  - **description <string>** — The description is a text string with up to 80 characters, that can be used to describe the use of the path.
  - **eth-cfm** — Configures the associated Ethernet connectivity fault management (CFM) parameters.
    - **mep md-admin-name <reference> ma-admin-name <reference> <mep-id>** — The maintenance endpoint (MEP) defined under the path is used for the G.8032 protocol messages, which are based on IEEE 802.1ag/Y.1731 CFM frames.
  - **rpl-end** — When configured, this path is expected to be one end of the RPL. This parameter must be configured in conjunction with the **rpl-node**.
  - **admin-state <keyword>** — This command enables or disables the path.
- **revert-time <number>** — This command configures the revert time for an Ethernet ring. The revert time is the time that the RPL will wait before returning to the blocked state.

Values:

```
*[ex:/configure eth-ring 1]
A:admin@PE-1# revert-time ?

revert-time <number>
<number> - <0,60..720> - seconds
Default   - 300
```

- **rpl-node <keyword{owner|neighbor}>** — A node can be designated as either the **owner** of the RPL, in which case this node is responsible for the RPL, or the **neighbor**, in which case this node is expected to be the neighbor to the RPL owner across the RPL. The neighbor is optional and is included to be compliant with the specification. This parameter must be configured in conjunction with the **rpl-end** parameter.
- **admin-state <keyword>** — This command enables or disables the Ethernet ring.
- **sub-ring** — The **sub-ring** command is beyond the scope of this chapter because it is only required for multiple ring topologies.

## Logging

Create following log-id on PE-2 to see major events logged to the console on PE-2. This is an optional step; alternatively, log 99 can be consulted.

```
# on PE-2:
configure {
  log {
    log-id "log1" {
      source {
        main true
      }
      destination {
        console
      }
    }
  }
}
```

## Configure encapsulation for ring ports

To configure R-APS, there should be at least two VPLS services for one Ethernet ring instance, one VPLS for the control channel and the other VPLSs for data channels. The control channel is used for R-APS signaling while the data channel is for user data traffic. The state of the data channels is inherited from the state of the control channel.

- An Ethernet ring needs R-APS tags to send and receive G.8032 signaling messages. To configure a control channel, an access SAP configuration is required on each path a port and path b port. The SAP configuration follows that of the port and must be either dot1Q or QinQ, so the control and data packets are either single tagged or double tagged. It is also possible to have the control VPLS using single tagged frames with the data VPLSs using double tagged frames; this requires the system to be configured with the **extended-default-qinq-sap-lookup** parameter (**configure service system extended-default-qinq-sap-lookup true**), with the ring path R-APS tags and control VPLS SAPs configured as qtag.0, and the data VPLS SAPs configured as qtag1.qtag2.

In the example in this chapter, single tags are used so the ports on the ring nodes are configured as follows:

```
# on PE-1, PE-2, PE-3:
configure {
  port 1/1/c1/1 {
    admin-state enable
    ethernet {
      mode access
      encap-type dot1q
    }
  }
  port 1/1/c2/1 {
    admin-state enable
    ethernet {
      mode access
      encap-type dot1q
    }
  }
}
```

## Configure Ethernet CFM

Ethernet ring requires Ethernet CFM domains, associations, and MEPs being configured. The domain format must be none and association name must be ITU-T carrier code-based (ICC-based - Y.1731). The minimum CCM interval for the SR OS nodes is 10ms. The Ethernet ring MEP requires a CCM interval, such as 10ms, 100ms, or 1s, to be configured.

The MEPs used for R-APS control normally have CCM configured on the control channel path MEPs for failure detection. Alternatively, detecting a failure of the ring may be achieved by running Ethernet in the first mile (EFM) at the port level if CCM is not possible at 10ms, 100ms, or 1s. Loss-of-signal, in conjunction with other OAM, is applicable only when the nodes are directly connected.

To omit the failure detecting CCMs, remove the **ccm true** from under the path MEPs and remove the **remote-mep** from under the **eth-cfm>domain>association** on all nodes.

Figure 13: Ethernet CFM configuration shows the Ethernet CFM configuration used here.

Figure 13: Ethernet CFM configuration

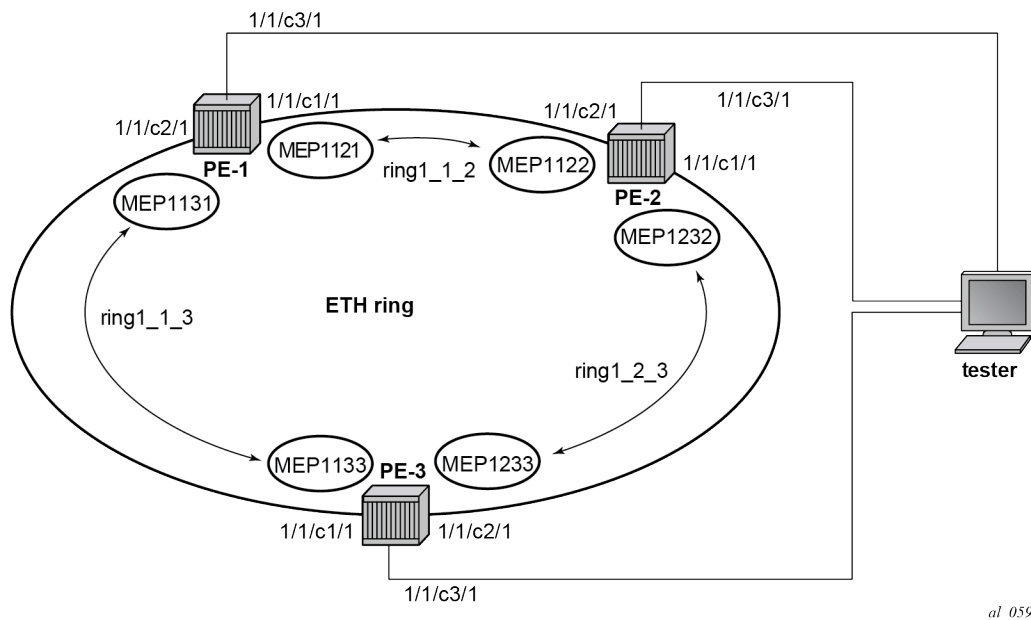

The Ethernet CFM configuration of the nodes is as follows.

```
# on PE-1:
configure {
  eth-cfm {
    domain "domain-1" {
      level 3
      format none
      md-index 1
      association "association-1" {
        icc-based "ring1_1_2"
        ma-index 1
        ccm-interval 1s
        remote-mep 1122 {
        }
      }
    }
  }
}
```

```
        association "association-2" {
            icc-based "ring1_1_3"
            ma-index 2
            ccm-interval 1s
            remote-mep 1133 {
            }
        }
    }
```

```
# on PE-2:
configure {
    eth-cfm {
        domain "domain-1" {
            level 3
            format none
            md-index 1
            association "association-1" {
                icc-based "ring1_2_3"
                ma-index 1
                ccm-interval 1s
                remote-mep 1233 {
                }
            }
            association "association-2" {
                icc-based "ring1_1_2"
                ma-index 2
                ccm-interval 1s
                remote-mep 1121 {
                }
            }
        }
    }
}
```

```
# on PE-3:
configure {
    eth-cfm {
        domain "domain-1" {
            level 3
            format none
            md-index 1
            association "association-1" {
                icc-based "ring1_1_3"
                ma-index 1
                ccm-interval 1s
                remote-mep 1131 {
                }
            }
            association "association-2" {
                icc-based "ring1_2_3"
                ma-index 2
                ccm-interval 1s
                remote-mep 1232 {
                }
            }
        }
    }
}
```

## Configure Ethernet ring

Two paths need to be configured to form a ring: path a and path b. In this example, VLAN tag 1 is used as control channel for R-APS signaling in the ring.

```
# on PE-1:
configure {
  eth-ring 1 {
    admin-state enable
    path "a" {
      admin-state enable
      port-and-raps-tag 1/1/c1/1:1
      eth-cfm {
        mep md-admin-name "domain-1" ma-admin-name "association-1" mep-id 1121 {
          admin-state enable
          ccm true
          control-mep true
        }
      }
    }
    path "b" {
      admin-state enable
      port-and-raps-tag 1/1/c2/1:1
      eth-cfm {
        mep md-admin-name "domain-1" ma-admin-name "association-2" mep-id 1131 {
          admin-state enable
          ccm true
          control-mep true
        }
      }
    }
  }
}
```

It is mandatory to configure a MEP in the path context, otherwise the following error is displayed:

```
*[ex:/configure eth-ring 1]
A:admin@PE-1# commit
MINOR: MGMT_CORE #4001: configure eth-ring 1 path "a" admin-state - Cannot enable path
without eth-cfm mep configured - configure eth-ring 1 path "a" admin-state
MINOR: MGMT_CORE #4001: configure eth-ring 1 path "b" admin-state - Cannot enable path
without eth-cfm mep configured - configure eth-ring 1 path "b" admin-state
```

While MEPs are mandatory, enabling CCM on the MEP in the path context as a failure detection mechanism is optional.

In order to define the RPL, node PE-2 is configured as the RPL owner and path b as the RPL end. The link between nodes PE-1 and PE-2 will be the RPL with node PE-2 blocking that link when the ring is fully operational.

```
# on PE-2:
configure {
  eth-ring 1 {
    admin-state enable
    revert-time 60
    rpl-node owner
    path "a" {
      admin-state enable
      port-and-raps-tag 1/1/c1/1:1
      eth-cfm {
        mep md-admin-name "domain-1" ma-admin-name "association-1" mep-id 1232 {
```



```

        admin-state enable
        ccm true
        control-mep true
    }
}
path "b" {
    admin-state enable
    port-and-raps-tag 1/1/c2/1:1
    rpl-end true
    eth-cfm {
        mep md-admin-name "domain-1" ma-admin-name "association-2" mep-id 1122 {
            admin-state enable
            ccm true
            control-mep true
        }
    }
}
}

```

It is not allowed to configure a path as an RPL end without having configured the node on this ring to be either the RPL **owner** or **neighbor** otherwise the following error message is reported.

```

*[ex:/configure eth-ring 1]
A:admin@PE-2# commit
MINOR: MGMT_CORE #4001: configure eth-ring 1 path "b" rpl-end - rpl-node must be set -
configure eth-ring 1 rpl-node

```

```

# on PE-3:
configure {
    eth-ring 1 {
        admin-state enable
        path "a" {
            admin-state enable
            port-and-raps-tag 1/1/c1/1:1
            eth-cfm {
                mep md-admin-name "domain-1" ma-admin-name "association-1" mep-id 1133 {
                    admin-state enable
                    ccm true
                    control-mep true
                }
            }
        }
    }
    path "b" {
        admin-state enable
        port-and-raps-tag 1/1/c2/1:1
        eth-cfm {
            mep md-admin-name "domain-1" ma-admin-name "association-2" mep-id 1233 {
                admin-state enable
                ccm true
                control-mep true
            }
        }
    }
}
}

```

Until the Ethernet ring instance is attached to the service (VPLS in this case), the ring operational status is down and the forwarding status of each port is blocked. This prevents operators from creating a loop by misconfiguration. This state can be seen on ring node PE-1 as follows:

```

[/]
A:admin@PE-1# show eth-ring 1

```

```

=====
Ethernet Ring 1 Information
=====
Description      : (Not Specified)
Admin State      : Up                Oper State       : Down
Node ID          : 02:09:ff:00:00:00
Guard Time      : 5 deciseconds    RPL Node         : rplNone
Max Revert Time  : 300 seconds       Time to Revert   : N/A
CCM Hold Down Time : 0 centiseconds  CCM Hold Up Time : 20 deciseconds
Compatible Version : 2
APS Tx PDU       : Request State: 0xB
                  Sub-Code       : 0x0
                  Status          : 0x20 ( BPR )
                  Node ID         : 02:09:ff:00:00:00

Defect Status    :

Sub-Ring Type    : none

-----
Ethernet Ring Path Summary
-----
Path Port        Raps-Tag   Admin/Oper     Type           Fwd State
-----
a 1/1/c1/1       1           Up/Down        normal          blocked
b 1/1/c2/1       1           Up/Down        normal          blocked
=====
  
```

## Configure control channel VPLS service

Paths a and b defined in the Ethernet ring must be added as SAPs into a VPLS service (standard VPLS in this example) using the **eth-ring** parameter. The SAP encapsulation values must match the values of the **port-and-raps-tag** configured for the associated path.

G.8032 uses the same R-APS tag value on all nodes on the ring, as configured in this example. However, the SR OS implementation relaxes this constraint by requiring the tag to match only on adjacent nodes.

```

# on PE-1:
configure {
  service {
    vpls "VPLS-1" {
      admin-state enable
      description "control channel VPLS 1 tag 1"
      service-id 1
      customer "1"
      sap 1/1/c1/1:1 {
        eth-ring 1
      }
      sap 1/1/c2/1:1 {
        eth-ring 1
      }
    }
  }
}
  
```

```

# on PE-2:
configure {
  service {
    vpls "VPLS-1" {
      admin-state enable
      description "control channel VPLS 1 tag 1"
      service-id 1
      customer "1"
      sap 1/1/c1/1:1 {
  
```

```

    eth-ring 1
  }
  sap 1/1/c2/1:1 {
    eth-ring 1
  }
}

# on PE-3:
configure {
  service {
    vpls "VPLS-1" {
      admin-state enable
      description "control channel VPLS 1 tag 1"
      service-id 1
      customer "1"
      sap 1/1/c1/1:1 {
        eth-ring 1
      }
      sap 1/1/c2/1:1 {
        eth-ring 1
      }
    }
  }
}

```

A normal SAP or SDP can be added in a control channel VPLS on condition the **eth-ring** parameter is present. Any attempt to add a SAP or SDP without this parameter into a control channel VPLS results in error messages being displayed. To trigger the following error messages, SAP 1/1/c3/1:1 is added without the eth-ring parameter.

```

*[ex:/configure service vpls "VPLS-1" sap 1/1/c3/1:1]
A:admin@PE-1# commit
MINOR: SVCMGR #2590: configure service vpls "VPLS-1" sap 1/1/c1/1:1 - Invalid Ethernet ring
configuration - Ring control SAP cannot be added to service that contains non-ring SAPs or SDP
bindings - configure service vpls "VPLS-1" sap 1/1/c1/1:1 eth-ring
MINOR: SVCMGR #2590: configure service vpls "VPLS-1" sap 1/1/c1/1:1 - Invalid Ethernet ring
configuration - Ethernet Ring Control service should only have controls saps from same ring -
configure service vpls "VPLS-1" sap 1/1/c1/1:1 eth-ring
MINOR: SVCMGR #2590: configure service vpls "VPLS-1" sap 1/1/c2/1:1 - Invalid Ethernet ring
configuration - Ring control SAP cannot be added to service that contains non-ring SAPs or SDP
bindings - configure service vpls "VPLS-1" sap 1/1/c2/1:1 eth-ring
MINOR: SVCMGR #2590: configure service vpls "VPLS-1" sap 1/1/c2/1:1 - Invalid Ethernet ring
configuration - Ethernet Ring Control service should only have controls saps from same ring -
configure service vpls "VPLS-1" sap 1/1/c2/1:1 eth-ring

```

In non-failure conditions, the Ethernet ring is operationally up and the RPL is blocking successfully on ring node PE-2 port 1/1/c2/1, as expected from the RPL owner and RPL end configuration.

An overview of all of the rings can be shown using the following commands, in this case on node PE-2.

The following command on PE-2 shows the Ethernet ring status.

```

[/]
A:admin@PE-2# show eth-ring status

=====
Ethernet Ring (Status information)
=====
Ring   Admin Oper   Path Information          State      MEP Information
ID     State State  Path      Tag           State      Ctrl-MEP CC-Intvl Defects
-----
1      Up    Up     a - 1/1/c1/1  1           Up         Yes      1      -----
                b - 1/1/c2/1  1           Up         Yes      1      -----
=====
Ethernet Tunnel MEP Defect Legend:

```

R = Rdi, M = MacStatus, C = RemoteCCM, E = ErrorCCM, X = XconCCM

The following command on PE-2 shows the ring and path forwarding states.

```
[/]
A:admin@PE-2# show eth-ring

=====
Ethernet Rings (summary)
=====
Ring Int  Admin Oper          Paths Summary          Path States
ID  ID  State State          a - 1/1/c1/1    1    b - 1/1/c2/1    1    U    B
-----
Ethernet Ring Summary Legend:  B - Blocked    U - Unblocked
```

The **show eth-ring 1** command on the different nodes shows specific information for Ethernet ring 1:

```
[/]
A:admin@PE-1# show eth-ring 1

=====
Ethernet Ring 1 Information
=====
Description          : (Not Specified)
Admin State          : Up                Oper State           : Up
Node ID              : 02:09:ff:00:00:00
Guard Time           : 5 deciseconds    RPL Node             : rplNone
Max Revert Time      : 300 seconds      Time to Revert       : N/A
CCM Hold Down Time   : 0 centiseconds  CCM Hold Up Time     : 20 deciseconds
Compatible Version    : 2
APS Tx PDU           : N/A
Defect Status        :

Sub-Ring Type        : none

-----
Ethernet Ring Path Summary
-----
Path Port          Raps-Tag    Admin/Oper      Type            Fwd State
-----
a 1/1/c1/1         1           Up/Up           normal          unblocked
b 1/1/c2/1         1           Up/Up           normal          unblocked
=====
```

```
[/]
A:admin@PE-2# show eth-ring 1

=====
Ethernet Ring 1 Information
=====
Description          : (Not Specified)
Admin State          : Up                Oper State           : Up
Node ID              : 02:0b:ff:00:00:00
Guard Time           : 5 deciseconds    RPL Node             : rp1owner
Max Revert Time      : 60 seconds      Time to Revert       : N/A
CCM Hold Down Time   : 0 centiseconds  CCM Hold Up Time     : 20 deciseconds
Compatible Version    : 2
APS Tx PDU           : Request State: 0x0
                   : Sub-Code          : 0x0
                   : Status           : 0xE0 ( RB DNF BPR )
```

```

Node ID      : 02:0b:ff:00:00:00
Defect Status :
Sub-Ring Type : none

-----
Ethernet Ring Path Summary
-----
Path Port      Raps-Tag  Admin/Oper  Type      Fwd State
-----
a 1/1/c1/1     1          Up/Up      normal    unblocked
b 1/1/c2/1     1          Up/Up      rplEnd    blocked
=====
  
```

Node PE-2 is the RPL owner and port 1/1/c2/1 is the RPL end. The **Max Revert Time** shows the configured value.

When a revert is pending after a failure restoration, the **Time to Revert** shows the number of seconds remaining before the revert occurs, as follows:

```

[/]
A:admin@PE-2# show eth-ring 1

=====
Ethernet Ring 1 Information
=====
Description      : (Not Specified)
Admin State      : Up
Oper State       : Up
Node ID          : 02:0b:ff:00:00:00
Guard Time      : 5 deciseconds
RPL Node        : rplowner
Max Revert Time  : 60 seconds
Time to Revert   : 49 seconds
CCM Hold Down Time : 0 centiseconds
CCM Hold Up Time : 20 deciseconds
Compatible Version : 2
APS Tx PDU       : N/A
Defect Status    :

Sub-Ring Type    : none

-----
Ethernet Ring Path Summary
-----
Path Port      Raps-Tag  Admin/Oper  Type      Fwd State
-----
a 1/1/c1/1     1          Up/Up      normal    unblocked
b 1/1/c2/1     1          Up/Up      rplEnd    unblocked
=====
  
```

On reversion, the following message is logged in log 99.

```

78 2023/05/05 16:12:16.588 CEST MINOR: ERING #2001 Base eth-ring-1
"Eth-Ring 1 path b changed fwd state to blocked"
  
```

The status of Ethernet ring 1 on PE-3 is as follows:

```

[/]
A:admin@PE-3# show eth-ring 1

=====
Ethernet Ring 1 Information
=====
Description      : (Not Specified)
Admin State      : Up
Oper State       : Up
  
```

```

Node ID       : 02:0d:ff:00:00:00
Guard Time   : 5 deciseconds   RPL Node      : rplNone
Max Revert Time : 300 seconds   Time to Revert : N/A
CCM Hold Down Time : 0 centiseconds CCM Hold Up Time : 20 deciseconds
Compatible Version : 2
APS Tx PDU    : N/A
Defect Status :
  
```

```
Sub-Ring Type : none
```

-----  
 Ethernet Ring Path Summary  
 -----

Path	Port	Raps-Tag	Admin/Oper	Type	Fwd State
a	1/1/c1/1	1	Up/Up	normal	unblocked
b	1/1/c2/1	1	Up/Up	normal	unblocked

=====

Finally, the following commands on PE-2 show the details of the individual paths:

```

[/]
A:admin@PE-2# show eth-ring 1 path a

=====
Ethernet Ring 1 Path Information
=====
Description      : (Not Specified)
Port             : 1/1/c1/1           Raps-Tag        : 1
Admin State      : Up                Oper State       : Up
Path Type       : normal           Fwd State       : unblocked
                                           Fwd State Change : 05/05/2023 16:11:17

Last Switch Command: noCmd
APS Rx PDU       : Request State: 0x0
                  Sub-Code       : 0x0
                  Status         : 0x20 ( BPR )
                  Node ID        : 02:0d:ff:00:00:00
  
```

```

[/]
A:admin@PE-2# show eth-ring 1 path b

=====
Ethernet Ring 1 Path Information
=====
Description      : (Not Specified)
Port             : 1/1/c2/1           Raps-Tag        : 1
Admin State      : Up                Oper State       : Up
Path Type       : rplEnd          Fwd State       : blocked
                                           Fwd State Change : 05/05/2023 16:12:17

Last Switch Command: noCmd
APS Rx PDU       : Request State: 0x0
                  Sub-Code       : 0x0
                  Status         : 0x20 ( BPR )
                  Node ID        : 02:0d:ff:00:00:00
  
```

## Configure user data channel VPLS service

The user data channels are created on a separate VPLS, "VPLS-100" in the example. The ring data channels must be on the same ports as the corresponding control channels configured above. The access into the data services can use SAPs or SDPs.

```
# on PE-1:
configure {
  service {
    vpls "VPLS-100" {
      admin-state enable
      description "data channel VPLS 100"
      service-id 100
      customer "1"
      sap 1/1/c1/1:100 {
        eth-ring 1
      }
      sap 1/1/c2/1:100 {
        eth-ring 1
      }
      sap 1/1/c3/1:100 {
      }
    }
  }
}
```

```
# on PE-2:
configure {
  service {
    vpls "VPLS-100" {
      admin-state enable
      description "data channel VPLS 100"
      service-id 100
      customer "1"
      sap 1/1/c1/1:100 {
        eth-ring 1
      }
      sap 1/1/c2/1:100 {
        eth-ring 1
      }
      sap 1/1/c3/1:100 {
      }
    }
  }
}
```

```
# on PE-3:
configure {
  service {
    vpls "VPLS-100" {
      admin-state enable
      description "data channel VPLS 100"
      service-id 100
      customer "1"
      sap 1/1/c1/1:100 {
        eth-ring 1
      }
      sap 1/1/c2/1:100 {
        eth-ring 1
      }
      sap 1/1/c3/1:100 {
      }
    }
  }
}
```

The following command on PE-1 shows all the SAPs that are configured to use Ethernet rings.

```
[/]
A:admin@PE-1# show service sap-using eth-ring

=====
Service Access Points (Ethernet Ring)
=====
SapId                SvcId      Eth-Ring Path  Admin Oper  Blocked Control/
                   State     State                               Data
-----
1/1/c1/1:1           1          1      a    Up    Up    No    Ctrl
1/1/c2/1:1           1          1      b    Up    Up    No    Ctrl
1/1/c1/1:100        100        1      a    Up    Up    No    Data
1/1/c2/1:100        100        1      b    Up    Up    No    Data
-----
Number of SAPs : 4
=====
```

## Debug

To emulate a failure on Ethernet ring 1, the unblocked port 1/1/c1/1 on node PE-2 is disabled, as follows.

```
# on PE-2:
configure {
  port 1/1/c1/1 {
    admin-state disable
```

The following messages are logged in log 99 when the failure occurs:

```
88 2023/05/05 16:15:44.598 CEST MINOR: ETH_CFM #2001 Base
"MEP 1/1/1232 highest defect is now defRemoteCCM"

87 2023/05/05 16:15:40.798 CEST MAJOR: SVC_MGR #2210 Base
"Processing of an access port state change event is finished and the status of all affected
SAPs on port 1/1/c1/1 has been updated."

86 2023/05/05 16:15:40.783 CEST MINOR: ERING #2001 Base eth-ring-1
"Eth-Ring 1 path b changed fwd state to unblocked"

85 2023/05/05 16:15:40.783 CEST MINOR: ERING #2001 Base eth-ring-1
"Eth-Ring 1 path a changed fwd state to blocked"

84 2023/05/05 16:15:40.782 CEST WARNING: SNMP #2004 Base 1/1/c1/1
"Interface 1/1/c1/1 is not operational"
```

For troubleshooting, the **tools dump eth-ring <ring-index>** command displays path information, the internal state of the control protocol, related statistics information and up to the last 20 protocol events (including messages sent and received, and the expiration of timers). An associated parameter **clear** exists, clearing the event information in this output when the command is entered. The following is an example of the output on node PE-2 with port 1/1/c1/1 disabled.

```
[/]
A:admin@PE-2# tools dump eth-ring 1

ringId 1 (Up/Up): numPaths 2 nodeId 02:0b:ff:00:00:00
SubRing: none (interconnect ring 0, propagateTc No), Cnt 0
path-a, port 1/1/c1/1 (Down), tag 1.0(Dn) status (Up/Dn/Blk)
```



```

cc (Dn/Up): Cnt 3/2 tm 000 00:18:38.370/000 00:14:03.350
state: Cnt 7 B/F 000 00:18:34.550/000 00:14:10.340, flag: 0x0
path-b, port 1/1/c2/1 (Up), tag 1.0(Up) status (Up/Up/Fwd)
cc (Dn/Up): Cnt 2/2 tm 000 00:08:53.380/000 00:08:56.620
state: Cnt 10 B/F 000 00:15:10.360/000 00:18:34.550, flag: 0x0
FsmState= PROT, Rpl = Owner, revert = 60 s, guard = 5 ds
Defects =
Running Timers = PduReTx
lastTxPdu = 0xb000 Sf
path-a Normal, RxId(I)= 02:0d:ff:00:00:00, rx= v1-0x0020 Nr, cmd= None
path-b Rpl, RxId= 02:0d:ff:00:00:00, rx= v1-0xb020 Sf, cmd= None
DebugInfo: aPathSts 6, bPathSts 5, pm (set/cclr) 0/0, txFlush 0
RxRaps: ok 28 nok 0 self 218, TmrExp - wtr 3(1), grd 4, wtb 0
Flush: cnt 15 (9/6/0) tm 000 00:18:38.340-000 00:18:38.340 Out/Ack 0/1
RxRawRaps: aPath 156 bPath 169 vPath 0
Now: 000 00:19:09.390 , softReset: No - noTx 0
  
```

Seq	Event	RxInfo(Path: NodeId-Bytes)	Dir	pA	pB	Time
====	=====	state:TxInfo (Bytes)	=====	====	====	=====
007	pdu B:	02:09:ff:00:00:00-0xb040 Sf(DNF)				
		PEND-G: 0x0020 Nr	Rx<--	Fwd	Blk	000 00:08:59.410
008	pdu B:	02:09:ff:00:00:00-0x0000 Nr				
		PEND-G: 0x0020 Nr	Rx<--	Fwd	Blk	000 00:08:59.410
009	pdu A:	02:09:ff:00:00:00-0xb040 Sf(DNF)				
		PEND-G: 0x0020 Nr	Rx<--	Fwd	Blk	000 00:08:59.420
010	pdu A:	02:09:ff:00:00:00-0x0000 Nr				
		PEND-G: 0x0020 Nr	Rx<--	Fwd	Blk	000 00:08:59.420
011	pdu B:	02:09:ff:00:00:00-0x0000 Nr				
		PEND-G: 0x0020 Nr	Rx<--	Fwd	Blk	000 00:08:59.510
012	pdu A:	02:09:ff:00:00:00-0x0000 Nr				
		PEND-G: 0x0020 Nr	Rx<--	Fwd	Blk	000 00:08:59.510
013	pdu B:	02:09:ff:00:00:00-0x0000 Nr				
		PEND : 0x0020 Nr	Rx<--	Fwd	Blk	000 00:08:59.610
014	pdu A:	02:09:ff:00:00:00-0x0000 Nr				
		PEND : 0x0020 Nr	Rx<--	Fwd	Blk	000 00:08:59.610
015	xWtr	IDLE : 0x00e0 Nr(RB DNF)	Tx-->	Fwd	Blk	000 00:10:14.360
016	aDn	PROT : 0xb000 Sf	TxF-->	Blk	Fwd	000 00:13:17.200
017	pdu B:	02:0d:ff:00:00:00-0xb020 Sf				
		PROT : 0xb000 Sf	RxF<--	Blk	Fwd	000 00:13:20.350
018	pdu A:	02:0d:ff:00:00:00-0x0020 Nr				
		PROT : 0xb000 Sf	Rx<--	Blk	Fwd	000 00:14:04.440
019	pdu B:	02:0d:ff:00:00:00-0x0020 Nr				
		PROT : 0xb000 Sf	Rx<--	Blk	Fwd	000 00:14:04.440
000	aUp	PEND-G: 0x0000 Nr	Tx-->	Blk	Fwd	000 00:14:05.360
001	pdu A:	02:0d:ff:00:00:00-0x0020 Nr				
		PEND : 0x0000 Nr	Rx<--	Blk	Fwd	000 00:14:10.340
002	pdu	PEND :	-----	Fwd	Fwd	000 00:14:10.340
003	pdu B:	02:0d:ff:00:00:00-0x0020 Nr				
		PEND :	Rx<--	Fwd	Fwd	000 00:14:10.340
004	xWtr	IDLE : 0x00a0 Nr(RB )	TxF-->	Fwd	Blk	000 00:15:10.360
005	aDn	PROT : 0xb000 Sf	TxF-->	Blk	Fwd	000 00:18:34.550
006	pdu B:	02:0d:ff:00:00:00-0xb020 Sf				
		PROT : 0xb000 Sf	RxF<--	Blk	Fwd	000 00:18:38.340

## Conclusion

Ethernet ring APS provides an optimal solution for designing native Ethernet services with ring topology. This protocol provides simple configuration, operation, and guaranteed fast protection time. SR OS also has a flexible encapsulation that allows dot1Q, QinQ, or PBB for the ring traffic. Ethernet ring APS can be utilized for various services such as mobile backhaul, business VPN access, aggregation, and core.

# GRE Tunnel Origination and Termination Using Non-system IP Addresses

This chapter provides information about GRE tunnel origination and termination using non-system IP addresses.

Topics in this chapter include:

- [Applicability](#)
- [Overview](#)
- [Configuration](#)
- [Conclusion](#)

## Applicability

This chapter was initially written based on SR OS Release 16.0.R5, but the MD-CLI in the current edition corresponds to SR OS Release 23.3.R2. GRE SDPs and auto-bind GRE tunnels can originate and terminate on a non-system IP address in SR OS Release 16.0.R4 or later.

## Overview

For scaling purposes, service providers typically deploy seamless MPLS or inter-AS scenarios. In many cases, the system IP address cannot be leaked between domains and a separate loopback address is used to terminate tunnels. GRE termination on a non-system IP address is supported in the following services:

- VPLS with manually configured GRE spoke-SDPs
- VPLS with BGP-AD using provisioned GRE SDPs (**provisioned-sdp use** or **provisioned-sdp prefer** commands)
- BGP-VPLS using provisioned GRE SDPs
- Epipe with manually configured GRE spoke-SDPs
- Epipe with BGP-VPWS using provisioned GRE SDPs
- VPRN with manually configured GRE spoke-SDPs
- VPRN with auto-bind GRE tunnel
- IES with manually configured GRE spoke-SDPs

This chapter focuses on MPLS-over-GRE termination, but IP-over-GRE termination is also supported.

## MPLS-over-GRE termination

GRE termination applies to GRE SDPs and auto-bind GRE tunnels concurrently on a system interface and on non-system interfaces with a subnet that is up to and including /16. In the following example, the non-system loopback address 10.0.1.1 with a subnet of /24 is configured as GRE termination on PE-1:

```
# on PE-1:
configure {
  router "Base" {
    interface "lo1" {
      loopback
      gre-termination true
      ipv4 {
        primary {
          address 10.0.1.1
          prefix-length 24
        }
      }
    }
  }
}
```

Only one interface can be configured as GRE termination. The following error is raised when attempting to configure a second loopback interface "lo2" as GRE termination on PE-1:

```
*[ex:/configure router "Base" interface "lo2"]
A:admin@Dut-A# commit
MINOR: COMMON #238: configure router "Base" interface "lo2" - Configuration change failed
validation - Multiple interfaces with gre-termination set in the router
```

Although the preceding examples are for loopback interfaces, GRE termination can also be configured on other router interfaces, but only one per node. The following shows an attempt to configure interface "int-PE-1-PE-2" on PE-1 as GRE termination. The same error message is raised. However, if it were the first interface on the node to be configured as GRE termination, the configuration would be accepted.

```
*[ex:/configure router "Base" interface "int-PE-1-PE-2"]
A:admin@Dut-A# commit
MINOR: COMMON #238: configure router "Base" interface "int-PE-1-PE-2" - Configuration change
failed validation - Multiple interfaces with gre-termination set in the router
```

The maximum size of the GRE termination subnet is /16.

GRE termination cannot be applied on the following interface types:

- Unnumbered network IP interfaces
- IES interfaces
- VPRN interfaces
- CSC VPRN interfaces

## MPLS-over-GRE origination

GRE SDPs and auto-bind GRE tunnels can originate and terminate on a non-system IP address. Manually configured SDPs can be configured with a non-system IP address as the far-end address. Optionally, a non-system local-end address can be configured for generating GRE from an interface other than the

system interface. In the following example on PE-1, GRE SDP 120 uses loopback address 10.0.1.1 as the local-end address and 10.0.2.1 on PE-2 as the far-end address.

```
# on PE-1:
configure {
  service {
    sdp 120 {
      admin-state enable
      local-end 10.0.1.1
      far-end {
        ip-address 10.0.2.1
      }
    }
  }
}
```

The local-end IP address can only be configured for GRE SDPs; the following error message is raised when attempting to configure an MPLS SDP with a local-end address:

```
*[ex:/configure service sdp 122]
A:admin@PE-1# commit
MINOR: SVCMGR #7720: configure service sdp 122 local-end - Invalid SDP configuration -
local-end is not supported for this sdp delivery-type.
```

The **local-end** parameter value complies with the following rules:

- A maximum of 15 distinct address values can be configured for all GRE SDPs in the **configure service sdp local-end** context, and all L2oGRE SDPs under the **configure service system gre-eth-bridged tunnel-termination** context.
- The same source address cannot be used in both contexts because an address configured for an L2oGRE SDP matches an internally created interface that is not available to other applications.
- The local-end address of a GRE SDP, when different from the system address, need not match the primary address of an interface that has the MPLS-over-GRE termination subnet configured, unless a GRE SDP or tunnel from the far-end router terminates on this address.

The primary IPv4 address of any local network IP interface, loopback or not, may be used. The following shows that IP address 192.168.12.1, as the IP address of the previously mentioned interface "int-PE-1-PE-2" toward PE-2, can be used as the local-end address:

```
# on PE-1:
configure {
  service {
    sdp 123 {
      admin-state enable
      local-end 192.168.12.1
      far-end {
        ip-address 10.0.2.1
      }
    }
  }
}
```

The following shows that an error message is raised when attempting to configure an invalid local-end IP address, that is, an IP address that is not primary on a local router interface. In this case, local-end IP address 10.99.1.1 does not exist on PE-1.

```
*[ex:/configure service sdp 120]
A:admin@PE-1# commit
MINOR: MGMT_CORE #4001: configure service sdp 120 - sdp 120: router interface with address
10.99.1.1 does not exist, or is not primary IPv4 address - configure router "Base" description
```

For services that support auto-binding to a GRE tunnel, the following command configures a single alternate source address (in this case, 10.0.1.1) per system:

```
# on PE-1:
configure {
  service {
    system {
      vpn-gre-source-ip 10.0.1.1
    }
  }
}
```

The default value of the single source address is the primary IPv4 address of the system interface. The value of the **vpn-gre-source-ip** parameter can be changed at any time. After a new value is configured, the system address will not be used in services that bind to the GRE tunnel.

The **vpn-gre-source-ip** parameter value complies with the following rules:

- This single source address counts toward the maximum of 15 distinct address values per system used by all GRE SDPs under the **configure service sdp local-end** context and all L2oGRE SDPs under the **configure service system gre-eth-bridged tunnel-termination** context.
- The same source address can be used in both **vpn-gre-source-ip** and **configure service sdp local-end** contexts.
- The same source address cannot be used in both **vpn-gre-source-ip** and **configure service system gre-eth-bridged tunnel-termination** contexts because an address configured for an L2oGRE SDP matches an internally created interface that is not available to other applications.
- The **vpn-gre-source-ip** address, when different from the system IP address, need not match the primary address of an interface that has the MPLS-over-GRE termination subnet configured, unless a GRE SDP or tunnel from the far-end router terminates on this address.

## Configuration

Figure 14: Example topology shows the example topology with three SR OS nodes in AS 64500. Services will be configured on PE-1 and PE-2, while RR-3 is a route reflector (RR).

Figure 14: Example topology

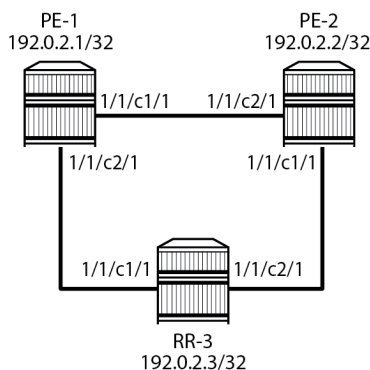

28868

The initial configuration on the three PEs includes:

- cards, MDAs, ports

- router interfaces. The IP addresses shown on the figure are the system IP addresses 192.0.2.x/32.
- IS-IS as IGP (alternatively, OSPF can be used)

GRE SDP termination on non-system IP addresses will be configured in the following use cases:

- VPLS with manually configured T-LDP signaled SDP
- Epipe with manually configured T-LDP signaled SDP
- BGP-VPLS using a provisioned BGP-signaled SDP
- BGP-AD in VPLS using a provisioned T-LDP signaled SDP
- BGP-VPWS using a provisioned BGP-signaled SDP
- VPRN with manually configured T-LDP signaled SDP
- VPRN with auto-bind to GRE tunnel
- IES with manually configured T-LDP signaled SDP

## MPLS-over-GRE termination

On PE-1, PE-2, and RR-3, loopback interface "lo1" is configured as GRE termination with IPv4 address 10.0.x.1/24 for PE-x. The configuration on PE-1 is as follows:

```
# on PE-1:
configure {
  router "Base" {
    interface "lo1" {
      loopback
      gre-termination true
      ipv4 {
        primary {
          address 10.0.1.1
          prefix-length 24
        }
      }
    }
  }
}
```

This loopback interface will be used in the SDP configuration. With a /24 subnet, the SDP origination can be any address in the subnet. This is useful for providing entropy in the outer IPv4 header for load-balancing over the IP network.

## MPLS-over-GRE origination: SDP local end

The local-end address must be reachable from the far-end router that terminates the GRE SDP. Therefore, the interface for this address can be added to IGP or BGP. Alternatively, a static route can be configured on the far-end router. In this example, IS-IS is enabled on the loopback interface with GRE termination, as follows:

```
# on PE-1, PE-2, RR-3:
configure {
  router "Base" {
    isis 0 {
      interface "lo1" {
      }
    }
  }
}
```

On PE-1, the following SDPs are configured with far-end 10.0.2.1 on PE-2 and local-end 10.0.1.1: SDP 120 with T-LDP signaling (default) and SDP 121 with BGP signaling.

```
# on PE-1:
configure exclusive
service {
  sdp 120 {
    admin-state enable
    local-end 10.0.1.1
    far-end {
      ip-address 10.0.2.1
    }
  }
  sdp 121 {
    admin-state enable
    local-end 10.0.1.1
    signaling bgp
    far-end {
      ip-address 10.0.2.1
    }
  }
}
```

### T-LDP signaled GRE SDPs

When T-LDP signaled SDPs, such as SDP 120 in the preceding example, are configured, T-LDP sessions are auto-created toward the far end of the SDPs. By default, LDP uses the system IP address as source address. However, if the source address for the T-LDP session does not match the destination transport address set by the remote PE, the T-LDP session will not come up and the GRE SDP will remain down. [Figure 15: Mismatched T-LDP transport addresses](#) shows an example where SDP auto-created T-LDP sessions use the local system addresses 192.0.2.x and far-end addresses 10.0.0.x, so the GRE SDPs will not come up.

Figure 15: Mismatched T-LDP transport addresses

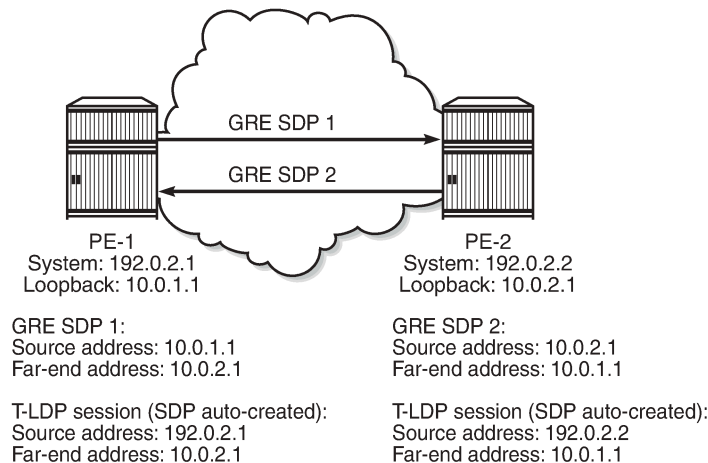

28869



Therefore, the local transport address of the T-LDP session must match the local-end address of the GRE SDP in the PE. These T-LDP sessions can be manually provisioned or auto-created via peer templates. The following configures T-LDP sessions between the non-system IP addresses on PE-1 and PE-2.

```
# on PE-1:
configure {
  router "Base" {
    ldp {
      targeted-session {
        peer 10.0.2.1 {
          local-lsr-id {
            interface-name "lo1"
          }
        }
      }
    }
  }
}

# on PE-2:
configure {
  router "Base" {
    ldp {
      targeted-session {
        peer 10.0.1.1 {
          local-lsr-id {
            interface-name "lo1"
          }
        }
      }
    }
  }
}
```

Figure 16: Matching T-LDP transport addresses shows the GRE T-LDP signaled SDPs with matching addresses for the T-LDP sessions.

Figure 16: Matching T-LDP transport addresses

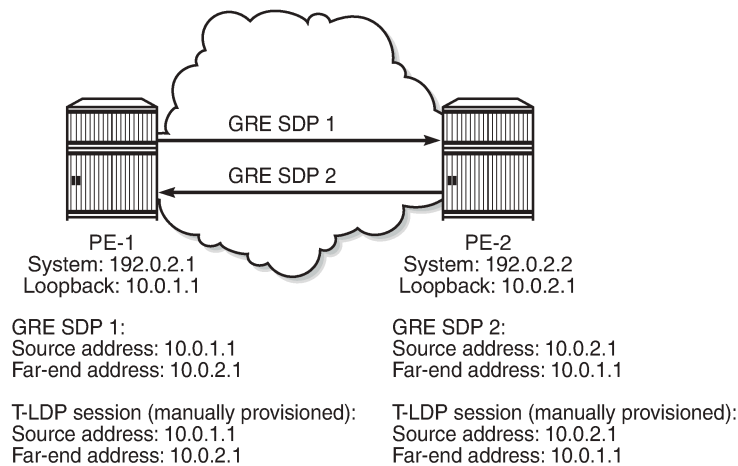

28870

## BGP configuration

In this example, the L2 and L3 services are configured on PE-1 and PE-2, while RR-3 acts as the RR. On PE-1, BGP is configured with neighbor 10.0.3.1 and local address 10.0.1.1, as follows. Address family L2-

VPN is required for L2 services using BGP-VPLS, BGP-AD, and BGP-VPWS; address family VPN-IPv4 is used for VPRN services.

```
# on PE-1:
configure {
  router "Base" {
    autonomous-system 64500
    bgp {
      rapid-withdrawal true
      split-horizon true
      group "internal" {
        type internal
        local-address 10.0.1.1
        family {
          vpn-ipv4 true
          l2-vpn true
        }
      }
      neighbor "10.0.3.1" {
        group "internal"
      }
    }
  }
}
```

The BGP configuration on PE-2 is similar with neighbor 10.0.3.1 and local address 10.0.2.1.

On RR-3, the BGP configuration is as follows.

```
# on RR-3:
configure {
  router "Base" {
    autonomous-system 64500
    bgp {
      rapid-withdrawal true
      split-horizon true
      group "internal" {
        type internal
        local-address 10.0.3.1
        family {
          vpn-ipv4 true
          l2-vpn true
        }
      }
      cluster {
        cluster-id 10.0.3.1
      }
    }
    neighbor "10.0.1.1" {
      group "internal"
    }
    neighbor "10.0.2.1" {
      group "internal"
    }
  }
}
```

The loopback addresses 10.0.x.1 are configured for the local and neighbor addresses.



**Note:**

When the local address 10.0.x.1 is not configured, the system address 192.0.2.x will be used instead. However, in that case, no BGP sessions will be established and, therefore, no BGP routes will be exchanged between 192.0.2.x and 10.0.y.1, and no spoke-SDPs will be auto-

created in L2 services using BGP-VPLS, BGP-AD, or BGP-VWPS. Likewise, no BGP-VPN routes will be exchanged between VPRNs on PE-1 and PE-2.

## L2 services

Figure 17: L2 services on PE-1 and PE-2 shows the example topology with the following L2 services configured on PE-1 and PE-2:

- VPLS 1 with manually configured spoke-SDP 120:1
- Epipe 2 with manually configured spoke-SDP 120:2
- BGP-VPLS 3 using PW template 1 (BGP-signaled SDP 121 is used)
- LDP VPLS 4 with BGP-AD using PW template 1 (T-LDP signaled SDP 120 is used)
- BGP-VPWS Epipe 5 using PW template 1 (BGP-signaled SDP 121 is used)

The CEs are VPRNs configured on the PEs and connected to the VPLSs via port cross-connect (PXC).

Figure 17: L2 services on PE-1 and PE-2

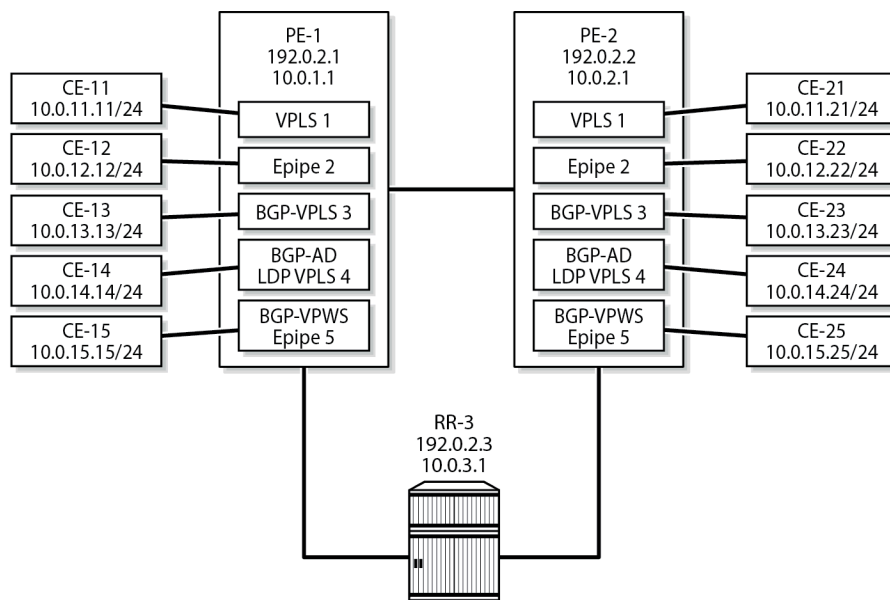

28871

For a description of the BGP-VPLS parameters, see the "BP VPLS" chapter; for BGP-AD, see the "LDP VPLS Using BGP Auto-Discovery" chapter; for BGP-VPWS, see the "BGP Virtual Private Wire Services" chapter in the *7450 ESS, 7750 SR, and 7950 XRS Layer 2 Services and EVPN Advanced Configuration Guide for MD CLI*. For BGP-VPLS, BGP-AD, and BGP-VPWS, PW template 1 is configured with the **provisioned-sdp use** command. The service configuration on PE-1 is as follows; the service configuration on PE-2 is similar.

```
# on PE-1:
configure {
  service {
    sdp 120 {
      admin-state enable
    }
  }
}
```

```
        local-end 10.0.1.1
        far-end {
            ip-address 10.0.2.1
        }
    }
    sdp 121 {
        admin-state enable
        local-end 10.0.1.1
        signaling bgp
        far-end {
            ip-address 10.0.2.1
        }
    }
    pw-template "PW1-use-prov-SDP" {
        pw-template-id 1
        provisioned-sdp use
    }
    vpls "VPLS-1" {
        admin-state enable
        description "VPLS 1 with manually configured spoke-SDP"
        service-id 1
        customer "1"
        spoke-sdp 120:1 {
        }
        sap pxc-10.a:1 {
        }
    }
    epipe "Epipe-2" {
        admin-state enable
        description "Epipe 2 with manually configured spoke-SDP"
        service-id 2
        customer "1"
        spoke-sdp 120:2 {
        }
        sap pxc-10.a:2 {
        }
    }
    vpls "BGP-VPLS-3" {
        admin-state enable
        description "BGP-VPLS with use provisioned SDP"
        service-id 3
        customer "1"
        bgp 1 {
            route-distinguisher "64500:3"
            route-target {
                export "target:64500:3"
                import "target:64500:3"
            }
            pw-template-binding "PW1-use-prov-SDP" {
            }
        }
    }
    bgp-vpls {
        admin-state enable
        maximum-ve-id 100
        ve {
            name "PE-1"
            id 1
        }
    }
    sap pxc-10.a:3 {
    }
}
vpls "BGP-AD VPLS-4" {
    admin-state enable
```

```

description "BGP-AD for LDP VPLS with use provisioned SDP"
service-id 4
customer "1"
bgp 1 {
  route-distinguisher "64500:4"
  route-target {
    export "target:64500:4"
    import "target:64500:4"
  }
  pw-template-binding "PW1-use-prov-SDP" {
  }
}
bgp-ad {
  admin-state enable
  vpls-id "64500:4"
}
sap pxc-10.a:4 {
}
}
epipe "BGP-VPWS-5" {
  admin-state enable
  description "BGP-VPWS with use provisioned SDP"
  service-id 5
  customer "1"
  bgp 1 {
    route-distinguisher "64500:5"
    route-target {
      export "target:64500:5"
      import "target:64500:5"
    }
    pw-template-binding "PW1-use-prov-SDP" {
    }
  }
  bgp-vpws {
    admin-state enable
    local-ve {
      name "PE-1"
      id 1
    }
    remote-ve "PE-2" {
      id 2
    }
  }
  sap pxc-10.a:5 {
  }
}
}

```

The following BGP sessions are established between PE-1 and RR-3 for the VPN-IPv4 and L2VPN address families:

```

[/]
A:admin@PE-1# show router bgp summary all
=====
BGP Summary
=====
Legend : D - Dynamic Neighbor
=====
Neighbor
Description
ServiceId          AS PktRcvd InQ Up/Down  State|Rcv/Act/Sent (Addr Family)
                  PktSent OutQ
-----

```

```
10.0.3.1
Def. Inst      64500      20      0 00h06m41s 0/0/0 (VpnIPv4)
                23      0                3/3/3 (L2VPN)
-----
```

On PE-1, the following T-LDP session is established to 10.0.2.1 on PE-2:

```
[/]
A:admin@PE-1# show router ldp session ipv4

=====
LDP IPv4 Sessions
=====
Peer LDP Id      Adj Type  State      Msg Sent  Msg Recv  Up Time
-----
10.0.2.1:0      Targeted Established 115       117       0d 00:09:26
-----
No. of IPv4 Sessions: 1
=====
```

On PE-1, the following SDPs are created with far end 10.0.2.1 and GRE delivery. For SDP 120, T-LDP signaling is used; BGP signaling is used for SDP 121.

```
[/]
A:admin@PE-1# show service sdp

=====
Services: Service Destination Points
=====
SdpId  AdmMTU  OprMTU  Far End      Adm  Opr      Del  LSP  Sig
-----
120    0       8954    10.0.2.1     Up  Up       GRE  n/a  TLDP
121    0       8954    10.0.2.1     Up  Up       GRE  n/a  BGP
-----
Number of SDPs : 2
-----
Legend: R = RSVP, L = LDP, B = BGP, M = MPLS-TP, n/a = Not Applicable
        I = SR-ISIS, 0 = SR-OSPF, T = SR-TE, F = FPE
=====
```

On PE-1, the following SDP-bindings are used:

```
[/]
A:admin@PE-1# show service sdp-using

=====
SDP Using
=====
SvcId  SdpId      Type  Far End      Opr  I.Label  E.Label
      State
-----
1      120:1      Spok  10.0.2.1     Up   524278  524278
2      120:2      Spok  10.0.2.1     Up   524276  524276
3      121:4294967294 BgpVp* 10.0.2.1     Up   524280  524279
4      120:4294967295 BgpAd  10.0.2.1     Up   524275  524275
5      121:4294967293 BgpVp* 10.0.2.1     Up   524277  524277
-----
Number of SDPs : 5
=====
```

\* indicates that the corresponding row element may have been truncated.

When the loopback interface "lo1" is configured as GRE termination on PE-1 and PE-2, the CEs can send traffic to each other. The following ping messages verify the connectivity between CE-11 and CE-21, CE-12 and CE-22, and so on:

```
[/]
A:admin@PE-1# ping 10.0.11.21 router-instance "CE-11" interval 0.1 output-format summary
PING 10.0.11.21 56 data bytes
!!!!!
---- 10.0.11.21 PING Statistics ----
5 packets transmitted, 5 packets received, 0.00% packet loss
round-trip min = 3.49ms, avg = 3.70ms, max = 4.11ms, stddev = 0.216ms

[/]
A:admin@PE-1# ping 10.0.12.22 router-instance "CE-12" interval 0.1 output-format summary
PING 10.0.12.22 56 data bytes
!!!!!
---- 10.0.12.22 PING Statistics ----
5 packets transmitted, 5 packets received, 0.00% packet loss
round-trip min = 3.54ms, avg = 4.58ms, max = 8.21ms, stddev = 1.82ms

[/]
A:admin@PE-1# ping 10.0.13.23 router-instance "CE-13" interval 0.1 output-format summary
PING 10.0.13.23 56 data bytes
!!!!!
---- 10.0.13.23 PING Statistics ----
5 packets transmitted, 5 packets received, 0.00% packet loss
round-trip min = 3.65ms, avg = 4.73ms, max = 8.67ms, stddev = 1.97ms

[/]
A:admin@PE-1# ping 10.0.14.24 router-instance "CE-14" interval 0.1 output-format summary
PING 10.0.14.24 56 data bytes
!!!!!
---- 10.0.14.24 PING Statistics ----
5 packets transmitted, 5 packets received, 0.00% packet loss
round-trip min = 3.76ms, avg = 6.67ms, max = 13.3ms, stddev = 3.82ms

[/]
A:admin@PE-1# ping 10.0.15.25 router-instance "CE-15" interval 0.1 output-format summary
PING 10.0.15.25 56 data bytes
!!!!!
---- 10.0.15.25 PING Statistics ----
5 packets transmitted, 5 packets received, 0.00% packet loss
round-trip min = 3.66ms, avg = 4.64ms, max = 7.89ms, stddev = 1.63ms
```

### L3 services

Figure 18: L3 services on PE-1 and PE-2 shows the example topology with the following three L3 services configured on PE-1 and PE-2:

- VPRN 6 with manually configured spoke-SDP 120:6
- VPRN 7 with auto-bind to GRE tunnel
- IES 8 with manually configured spoke-SDP 120:8

Figure 18: L3 services on PE-1 and PE-2

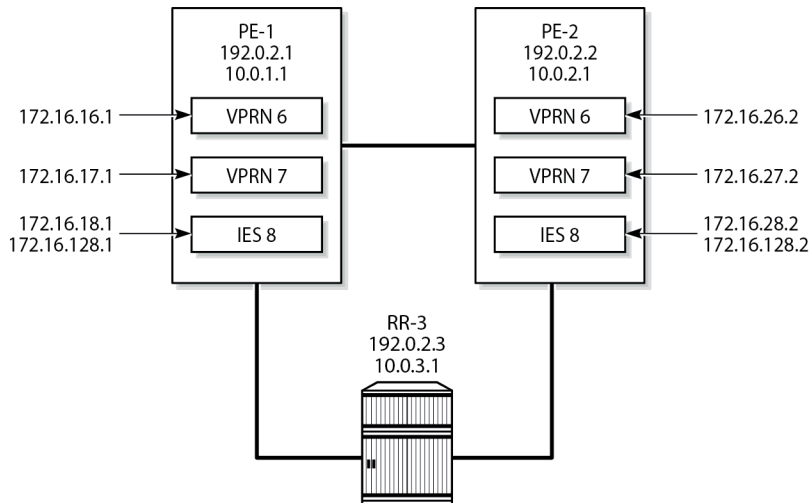

28872

VPRN 6 is configured with a loopback interface and a GRE spoke-SDP, as follows:

```
# on PE-1:
configure {
  service {
    system {
      bgp-auto-rd-range {
        ip-address 10.0.1.1
        community-value {
          start 60000
          end 65000
        }
      }
    }
  }
  vprn "VPRN-6 with GRE spoke-SDP" {
    admin-state enable
    service-id 6
    customer "1"
    bgp-ipvpn {
      mpls {
        admin-state enable
        route-distinguisher auto-rd
        vrf-target {
          community "target:64500:6"
        }
      }
    }
    interface "lo6" {
      loopback true
      ipv4 {
        primary {
          address 172.16.16.1
          prefix-length 32
        }
      }
    }
    spoke-sdp 120:6 {
  }
```



```
}

```

The following forwarding information base (FIB) for VPRN 6 shows that the remote prefix is reachable via a transport tunnel using SDP 120:

```
[/]
A:admin@PE-1# show router 6 fib 1

=====
FIB Display
=====
Prefix [Flags]                                     Protocol
  NextHop
-----
172.16.16.1/32                                     LOCAL
  172.16.16.1 (lo6)
172.16.26.2/32                                     BGP_VPN
  10.0.2.1 (VPRN Label:524273 Transport:SDP:120)
-----
Total Entries : 2
=====
```

VPRN 7 is configured with **auto-bind-tunnel** and the tunnel needs to be resolved using GRE. For services that support auto-binding to a GRE tunnel, the **vpn-gre-source-ip** parameter defines a single alternate source address for all VPRNs on the system. On PE-1, the configuration is as follows:

```
# on PE-1:
configure {
  service {
    system {
      vpn-gre-source-ip 10.0.1.1
    }
    vprn "VPRN-7 with auto-bind GRE" {
      admin-state enable
      service-id 7
      customer "1"
      bgp-ipvpn {
        mpls {
          admin-state enable
          route-distinguisher auto-rd
          vrf-target {
            community "target:64500:7"
          }
          auto-bind-tunnel {
            resolution filter
            resolution-filter {
              gre true
            }
          }
        }
      }
    }
    interface "lo7" {
      loopback true
      ipv4 {
        primary {
          address 172.16.17.1
          prefix-length 24
        }
      }
    }
  }
}
```

```
}

```

The following FIB for VPRN 7 shows that the remote prefix is reachable via a GRE transport tunnel:

```
[/]
A:admin@PE-1# show router 7 fib 1

=====
FIB Display
=====
Prefix [Flags]                                Protocol
NextHop
-----
172.16.17.0/24                                LOCAL
  172.16.17.0 (lo7)
172.16.27.0/24                                BGP_VPN
  10.0.2.1 (VPRN Label:524271 Transport:GRE)
-----
Total Entries : 2
=====
```

IES 8 has an interface with a manually configured GRE spoke-SDP, as follows:

```
# on PE-1:
configure {
  service {
    ies "IES-8" {
      admin-state enable
      service-id 8
      customer "1"
      interface "int-IES8-PE-1-PE-2" {
        spoke-sdp 120:8 {
        }
        ipv4 {
          primary {
            address 172.16.128.1
            prefix-length 30
          }
        }
      }
      interface "lo8" {
        loopback true
        ipv4 {
          primary {
            address 172.16.18.1
            prefix-length 24
          }
        }
      }
    }
  }
}
```

On PE-1, the connectivity over the GRE spoke-SDP is verified as follows:

```
[/]
A:admin@PE-1# ping 172.16.128.2 interval 0.1 output-format summary
PING 172.16.128.2 56 data bytes
!!!!
---- 172.16.128.2 PING Statistics ----
5 packets transmitted, 5 packets received, 0.00% packet loss
```

```
round-trip min = 2.57ms, avg = 2.73ms, max = 3.01ms, stddev = 0.168ms
```

## Conclusion

By default, GRE SDPs and auto-bind GRE tunnels are originated and terminated on the system IP address, but it is possible to use non-system IP addresses. This is useful in cases where the system IP address cannot be leaked between domains and a separate loopback address must be used to terminate tunnels.

# Inter-AS Option B Label Security for IP-VPN and EVPN Routes

This chapter provides information about inter-AS option B label security for IP-VPN and EVPN routes.

Topics in this chapter include:

- [Applicability](#)
- [Overview](#)
- [Configuration](#)
- [Conclusion](#)

## Applicability

The information and the configuration in this chapter are based on SR OS Release 24.3.R1. Inter-AS option B label security for IP-VPN routes is supported in SR OS Release 16.0.R4, and later. Inter-AS option B label security for EVPN routes is supported in SR OS Release 23.3.R2, and later.

## Overview

In inter-AS option B interconnects, the Autonomous System Border Routers (ASBRs) can filter BGP IP-VPN or BGP EVPN routes based on route target (RT). In addition, BGP neighbor trust prevents label spoofing in inter-AS option B for the VPN-IPv4, VPN-IPv6, and EVPN address families. In networks where ASBRs advertise routes to multiple peer ASBRs, an ASBR may drop packets on IP interfaces that are configured as **untrusted** with the **default-forwarding** argument set to the **drop** command option:

```
# on ASBR: configure router interface <.> untrusted default-forwarding drop
```

By default, all IP interfaces between ASBRs are trusted and the datapath allows all packets. It is possible to configure a number of maximum 15 interfaces as **untrusted**. The **default-forwarding** argument can be set to the **forward** option (default behavior) or to the **drop** option.



### Note:

When an IP interface is configured as **untrusted** without the **default-forwarding drop** option or when the untrusted IP interface is configured with the (default) **default-forwarding forward** option, the datapath allows all packets and the behavior is the same as when the **untrusted** command is not configured.

Traffic is only dropped when the IP interface is configured with **untrusted default-forwarding drop**.

[Table 3: Untrusted interfaces with default-forwarding forward option allow all IP-VPN and EVPN routes](#) shows that the datapath allows all IP-VPN and EVPN traffic when the interface is configured as **untrusted**

with **default-forwarding** set to **forward**. There is no need to configure neighbor-trust for VPN-IPv4, VPN-IPv6, or EVPN.

Table 3: Untrusted interfaces with default-forwarding forward option allow all IP-VPN and EVPN routes

untrusted configuration	neighbor-trust configured			traffic allowed		
	VPN-IPv4	VPN-IPv6	EVPN	VPN-IPv4	VPN-IPv6	EVPN
untrusted forward	no	no	no	yes	yes	yes
untrusted forward	no	no	yes	yes	yes	yes
untrusted forward	no	yes	no	yes	yes	yes
untrusted forward	no	yes	yes	yes	yes	yes
untrusted forward	yes	no	no	yes	yes	yes
untrusted forward	yes	no	yes	yes	yes	yes
untrusted forward	yes	yes	no	yes	yes	yes
untrusted forward	yes	yes	yes	yes	yes	yes

In contrast, the datapath drops all labeled packets on untrusted IP interfaces configured with the **default-forwarding drop** option. To allow the datapath to provide an exception to the default forwarding handling for Ingress Label Maps (ILMs), BGP must flag those ILMs to the data path. The following **neighbor-trust** command enables the exceptional ILM forwarding behavior for multiple VPN address families: VPN-IPv4, VPN-IPv6, and EVPN:

```
# on ASBR:
configure {
  router "Base" {
    bgp {
      neighbor-trust {
        vpn-ipv4 true
        vpn-ipv6 true
        evpn true
      }
    }
  }
}
```

Table 4: BGP neighbor-trust defines what traffic is allowed on untrusted interfaces with default-forwarding drop option shows what traffic is allowed on an untrusted interface configured with the default-forwarding drop option when BGP neighbor-trust is configured for VPN-IP or EVPN address families.

Table 4: BGP neighbor-trust defines what traffic is allowed on untrusted interfaces with default-forwarding drop option

untrusted configuration	neighbor-trust configured			traffic allowed		
	VPN-IPv4	VPN-IPv6	EVPN	VPN-IPv4	VPN-IPv6	EVPN
untrusted drop	no	no	no	no	no	no
untrusted drop	no	no	yes	no	no	yes
untrusted drop	no	yes	no	no	yes	no
untrusted drop	no	yes	yes	no	yes	yes
untrusted drop	yes	no	no	yes	no	no
untrusted drop	yes	no	yes	yes	no	yes
untrusted drop	yes	yes	no	yes	yes	no
untrusted drop	yes	yes	yes	yes	yes	yes

## Configuration

The following scenarios are described in this chapter:

- [Inter-AS option B label security with services configured on PEs only](#)
- [Inter-AS option B label security with services configured on PEs and on ASBR](#)

### Inter-AS option B label security with services configured on PEs only

Figure 19: [Example topology with services on PEs](#) shows the example topology with the following services configured on PE-1 and PE-4:

- BGP-IPVPN "VPRN-1"
- BGP-EVPN "VPRN-2"
- EVPN VPLS "VPLS-3"
- EVPN VPWS "Epipe-4"
- EVPN R-VPLS "BD-5" in IES "IES-55"

Figure 19: Example topology with services on PEs

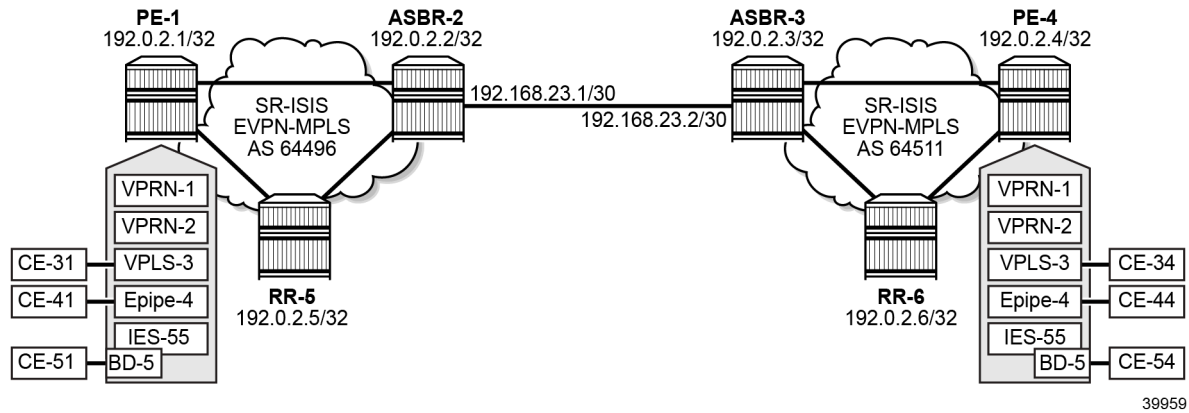

## Initial configuration

The initial configuration on the nodes in the example topology includes the following:

- cards, MDAs, ports
- router interfaces
- IS-IS between PE-1, RR-5, and ASBR-2 in AS 64496 and between PE-4, RR-6, and ASBR-3 in AS 64511, but not between the ASBRs
- SR-ISIS between PE-1 and ASBR-2 in AS 64496 and between PE-4 and ASBR-3 in AS 64511
- BGP for the VPN-IPv4, VPN-IPv6, and EVPN address families:
  - IBGP in AS 64496 with route reflector RR-5 and clients PE-1 and ASBR-2
  - IBGP in AS 64511 with route reflector RR-6 and clients PE-4 and ASBR-3
  - EBGP between ASBR-2 and ASBR-3

The BGP configuration on PE-1 is as follows:

```
# on PE-1:
configure {
  router "Base" {
    autonomous-system 64496
    bgp {
      rapid-withdrawal true
      split-horizon true
      rapid-update {
        vpn-ipv4 true
        vpn-ipv6 true
        evpn true
      }
      group "internal" {
        peer-as 64496
      }
    }
    neighbor "192.0.2.5" {
      group "internal"
      family {
        vpn-ipv4 true
        vpn-ipv6 true
      }
    }
  }
}
```

```

    evpn true
  }
}

```

The BGP configuration on RR-5 is as follows:

```

# on RR-5:
configure {
  router "Base" {
    autonomous-system 64496
    bgp {
      rapid-withdrawal true
      split-horizon true
      rapid-update {
        vpn-ipv4 true
        vpn-ipv6 true
        evpn true
      }
    }
    group "internal" {
      peer-as 64496
      cluster {
        cluster-id 192.0.2.5
      }
    }
    neighbor "192.0.2.1" {
      group "internal"
      family {
        vpn-ipv4 true
        vpn-ipv6 true
        evpn true
      }
    }
    neighbor "192.0.2.2" {
      group "internal"
      family {
        vpn-ipv4 true
        vpn-ipv6 true
        evpn true
      }
    }
  }
}

```

The BGP configuration on ASBR-2 is as follows:

```

# on ASBR-2:
configure exclusive
  router "Base" {
    autonomous-system 64496
    bgp {
      inter-as-vpn true      # required for inter-AS VPRN model B
      rapid-withdrawal true
      split-horizon true
      rapid-update {
        vpn-ipv4 true
        vpn-ipv6 true
        evpn true
      }
    }
    next-hop-resolution {
      labeled-routes {
        transport-tunnel {
          family vpn {
            resolution any
          }
        }
      }
    }
  }
}

```



```

    }
  }
  group "external" {
    ebgp-default-reject-policy {
      import false
      export false
    }
    type external
    peer-as 64511
  }
  group "internal" {
    peer-as 64496
  }
  neighbor "192.0.2.5" {
    group "internal"
    family {
      vpn-ipv4 true
      vpn-ipv6 true
      evpn true
    }
  }
  neighbor "192.168.23.2" {
    group "external"
    family {
      vpn-ipv4 true
      vpn-ipv6 true
      evpn true
    }
  }
}

```

The BGP configuration on the nodes in AS 64511 is similar.

## Services configuration

The following services are configured on PE-1:

```

# on PE-1:
configure {
  service {
    vprn "VPRN-1" {
      admin-state enable
      service-id 1
      customer "1"
      bgp-ipvpn {
        mpls {
          admin-state enable
          route-distinguisher "192.0.2.1:1"
          vrf-target {
            community "target:64496:1"
          }
          auto-bind-tunnel {
            resolution any
          }
        }
      }
    }
  }
  interface "int-test-1" {
    ipv4 {
      primary {
        address 10.1.1.1
        prefix-length 24
      }
    }
  }
}

```

```
    }
    sap 1/1/c10/1:1 {
    }
    ipv6 {
        address 2001:db8::10:1:1:1 {
            prefix-length 120
        }
    }
}
vprn "VPRN-2" {
    admin-state enable
    service-id 2
    customer "1"
    bgp-evpn {
        mpls 1 {
            admin-state enable
            route-distinguisher "192.0.2.1:2"
            vrf-target {
                community "target:64496:2"
            }
            auto-bind-tunnel {
                resolution any
            }
        }
    }
    interface "int-test-2" {
        ipv4 {
            primary {
                address 10.2.1.1
                prefix-length 24
            }
        }
        sap 1/1/c10/1:2 {
        }
        ipv6 {
            address 2001:db8::10:2:1:1 {
                prefix-length 120
            }
        }
    }
}
vpls "VPLS-3" {
    admin-state enable
    service-id 3
    customer "1"
    bgp 1 {
        route-target {
            export "target:64496:3"
            import "target:64496:3"
        }
    }
    bgp-evpn {
        evi 3
        mpls 1 {
            admin-state enable
            auto-bind-tunnel {
                resolution any
            }
        }
    }
    sap 1/1/c10/1:3 {
    }
}
```

```
epipe "Epipe-4" {
  admin-state enable
  service-id 4
  customer "1"
  bgp 1 {
    route-target {
      export "target:64496:4"
      import "target:64496:4"
    }
  }
  sap 1/1/c10/1:4 {
    description "SAP to CE-41"
  }
  bgp-evpn {
    evi 4
    local-attachment-circuit "PE1" {
      eth-tag 1
    }
    remote-attachment-circuit "PE4" {
      eth-tag 4
    }
    mpls 1 {
      admin-state enable
      auto-bind-tunnel {
        resolution any
      }
    }
  }
}
vpls "BD-5" {
  admin-state enable
  service-id 5
  customer "1"
  routed-vpls {
  }
  bgp 1 {
    route-target {
      export "target:64496:5"
      import "target:64496:5"
    }
  }
  bgp-evpn {
    evi 5
    mpls 1 {
      admin-state enable
      auto-bind-tunnel {
        resolution any
      }
    }
  }
  sap 1/1/c10/1:5 {
  }
}
ies "IES-55" {
  admin-state enable
  service-id 55
  customer "1"
  interface "int-BD-5" {
    vpls "BD-5" {
    }
  }
  ipv4 {
    primary {
      address 172.16.5.1
      prefix-length 24
    }
  }
}
```

```

    }
  }
  ipv6 {
    address 2001:db8::16:5:1 {
      prefix-length 120
    }
  }
}

```

The configuration of the services on PE-4 in AS 64511 is similar.

## Inter-AS option B services using trusted interfaces

By default, IP interfaces are trusted. With trusted interfaces between ASBR-2 and ASBR-3, traffic can be sent from the services or the CEs connected to the services on PE-1 to the corresponding services on PE-4.

## Inter-AS option B services using untrusted interfaces with default-forwarding forward option

It is possible to configure the interface from ASBR-3 to ASBR-2 as **untrusted** with the **default-forwarding** argument set to the **forward** option, or even without this **default-forwarding** argument, because the default option is **forward**:

```

# on ASBR-3:
configure {
  router "Base" {
    interface "int-ASBR-3-ASBR-2" {
      port 1/1/c2/1:1000
      ipv4 {
        primary {
          address 192.168.23.2
          prefix-length 30
        }
      }
      untrusted {
        default-forwarding forward
      }
    }
  }
}

```

With this configuration where packets on the untrusted interfaces are forwarded by default, it is possible to send traffic between the services on PE-1 and the services on PE-4:

```

[/]
A:admin@PE-1# ping 10.1.4.4 router-instance "VPRN-1" count 1
PING 10.1.4.4 56 data bytes
64 bytes from 10.1.4.4: icmp_seq=1 ttl=64 time=2.84ms.

---- 10.1.4.4 PING Statistics ----
1 packet transmitted, 1 packet received, 0.00% packet loss
round-trip min = 2.84ms, avg = 2.84ms, max = 2.84ms, stddev = 0.000ms

[/]
A:admin@PE-1# ping 2001:db8::10:1:4:4 router-instance "VPRN-1" count 1
PING 2001:db8::10:1:4:4 56 data bytes
64 bytes from 2001:db8::10:1:4:4 icmp_seq=1 hlim=64 time=2.85ms.

```

```
---- 2001:db8::10:1:4:4 PING Statistics ----
1 packet transmitted, 1 packet received, 0.00% packet loss
round-trip min = 2.85ms, avg = 2.85ms, max = 2.85ms, stddev = 0.000ms

[/]
A:admin@PE-1# ping 10.2.4.4 router-instance "VPRN-2" count 1
PING 10.2.4.4 56 data bytes
64 bytes from 10.2.4.4: icmp_seq=1 ttl=64 time=2.72ms.

---- 10.2.4.4 PING Statistics ----
1 packet transmitted, 1 packet received, 0.00% packet loss
round-trip min = 2.72ms, avg = 2.72ms, max = 2.72ms, stddev = 0.000ms

[/]
A:admin@PE-1# ping 2001:db8::10:2:4:4 router-instance "VPRN-2" count 1
PING 2001:db8::10:2:4:4 56 data bytes
64 bytes from 2001:db8::10:2:4:4 icmp_seq=1 hlim=64 time=2.96ms.

---- 2001:db8::10:2:4:4 PING Statistics ----
1 packet transmitted, 1 packet received, 0.00% packet loss
round-trip min = 2.96ms, avg = 2.96ms, max = 2.96ms, stddev = 0.000ms

[/]
A:admin@PE-1# ping 172.16.3.4 router-instance "CE-31" count 1
PING 172.16.3.4 56 data bytes
64 bytes from 172.16.3.4: icmp_seq=1 ttl=64 time=4.09ms.

---- 172.16.3.4 PING Statistics ----
1 packet transmitted, 1 packet received, 0.00% packet loss
round-trip min = 4.09ms, avg = 4.09ms, max = 4.09ms, stddev = 0.000ms

[/]
A:admin@PE-1# ping 2001:db8::16:3:4 router-instance "CE-31" count 1
PING 2001:db8::16:3:4 56 data bytes
64 bytes from 2001:db8::16:3:4 icmp_seq=1 hlim=64 time=3.81ms.

---- 2001:db8::16:3:4 PING Statistics ----
1 packet transmitted, 1 packet received, 0.00% packet loss
round-trip min = 3.81ms, avg = 3.81ms, max = 3.81ms, stddev = 0.000ms

[/]
A:admin@PE-1# ping 172.16.4.4 router-instance "CE-41" count 1
PING 172.16.4.4 56 data bytes
64 bytes from 172.16.4.4: icmp_seq=1 ttl=64 time=3.67ms.

---- 172.16.4.4 PING Statistics ----
1 packet transmitted, 1 packet received, 0.00% packet loss
round-trip min = 3.67ms, avg = 3.67ms, max = 3.67ms, stddev = 0.000ms

[/]
A:admin@PE-1# ping 2001:db8::16:4:4 router-instance "CE-41" count 1
PING 2001:db8::16:4:4 56 data bytes
64 bytes from 2001:db8::16:4:4 icmp_seq=1 hlim=64 time=3.62ms.

---- 2001:db8::16:4:4 PING Statistics ----
1 packet transmitted, 1 packet received, 0.00% packet loss
round-trip min = 3.62ms, avg = 3.62ms, max = 3.62ms, stddev = 0.000ms

[/]
A:admin@PE-1# ping 172.16.5.54 router-instance "CE-51" count 1
PING 172.16.5.54 56 data bytes
64 bytes from 172.16.5.54: icmp_seq=1 ttl=64 time=4.04ms.

---- 172.16.5.54 PING Statistics ----
```

```

1 packet transmitted, 1 packet received, 0.00% packet loss
round-trip min = 4.04ms, avg = 4.04ms, max = 4.04ms, stddev = 0.000ms

[/]
A:admin@PE-1# ping 2001:db8::16:5:54 router-instance "CE-51" count 1
PING 2001:db8::16:5:54 56 data bytes
64 bytes from 2001:db8::16:5:54 icmp_seq=1 hlim=64 time=3.91ms.

---- 2001:db8::16:5:54 PING Statistics ----
1 packet transmitted, 1 packet received, 0.00% packet loss
round-trip min = 3.91ms, avg = 3.91ms, max = 3.91ms, stddev = 0.000ms
  
```

All traffic is forwarded, so there is no need to configure the **neighbor-trust** command. If the **neighbor-trust** command is configured for VPN-IPv4, VPN-IPv6, EVPN, or any combination of these, this command has no effect. As an example, the **neighbor-trust** command is configured for the VPN-IPv4 and EVPN address families, as follows:

```

# on ASBR-3:
configure {
  router "Base" {
    bgp {
      neighbor-trust {
        vpn-ipv4 true
        vpn-ipv6 false
        evpn true
      }
    }
  }
}
  
```

The datapath forwards all traffic for the corresponding services, regardless of this **neighbor-trust** configuration:

```

[/]
A:admin@PE-1# ping 10.1.4.4 router-instance "VPRN-1" count 1      # VPN-IPv4
PING 10.1.4.4 56 data bytes
64 bytes from 10.1.4.4: icmp_seq=1 ttl=64 time=2.84ms.

---- 10.1.4.4 PING Statistics ----
1 packet transmitted, 1 packet received, 0.00% packet loss
round-trip min = 2.84ms, avg = 2.84ms, max = 2.84ms, stddev = 0.000ms

[/]
A:admin@PE-1# ping 2001:db8::10:1:4:4 router-instance "VPRN-1" count 1
PING 2001:db8::10:1:4:4 56 data bytes
64 bytes from 2001:db8::10:1:4:4 icmp_seq=1 hlim=64 time=3.13ms.

---- 2001:db8::10:1:4:4 PING Statistics ----
1 packet transmitted, 1 packet received, 0.00% packet loss
round-trip min = 3.13ms, avg = 3.13ms, max = 3.13ms, stddev = 0.000ms

[/]
A:admin@PE-1# ping 10.2.4.4 router-instance "VPRN-2" count 1      # EVPN IFL
PING 10.2.4.4 56 data bytes
64 bytes from 10.2.4.4: icmp_seq=1 ttl=64 time=2.54ms.

---- 10.2.4.4 PING Statistics ----
1 packet transmitted, 1 packet received, 0.00% packet loss
round-trip min = 2.54ms, avg = 2.54ms, max = 2.54ms, stddev = 0.000ms

[/]
A:admin@PE-1# ping 2001:db8::10:2:4:4 router-instance "VPRN-2" count 1
PING 2001:db8::10:2:4:4 56 data bytes
64 bytes from 2001:db8::10:2:4:4 icmp_seq=1 hlim=64 time=2.78ms.
  
```

```
---- 2001:db8::10:2:4:4 PING Statistics ----
1 packet transmitted, 1 packet received, 0.00% packet loss
round-trip min = 2.78ms, avg = 2.78ms, max = 2.78ms, stddev = 0.000ms

[/]
A:admin@PE-1# ping 172.16.3.4 router-instance "CE-31" count 1 # EVPN VPLS
PING 172.16.3.4 56 data bytes
64 bytes from 172.16.3.4: icmp_seq=1 ttl=64 time=3.75ms.

---- 172.16.3.4 PING Statistics ----
1 packet transmitted, 1 packet received, 0.00% packet loss
round-trip min = 3.75ms, avg = 3.75ms, max = 3.75ms, stddev = 0.000ms

[/]
A:admin@PE-1# ping 2001:db8::16:3:4 router-instance "CE-31" count 1
PING 2001:db8::16:3:4 56 data bytes
64 bytes from 2001:db8::16:3:4 icmp_seq=1 hlim=64 time=3.68ms.

---- 2001:db8::16:3:4 PING Statistics ----
1 packet transmitted, 1 packet received, 0.00% packet loss
round-trip min = 3.68ms, avg = 3.68ms, max = 3.68ms, stddev = 0.000ms

[/]
A:admin@PE-1# ping 172.16.4.4 router-instance "CE-41" count 1 # EVPN VPWS
PING 172.16.4.4 56 data bytes
64 bytes from 172.16.4.4: icmp_seq=1 ttl=64 time=3.69ms.

---- 172.16.4.4 PING Statistics ----
1 packet transmitted, 1 packet received, 0.00% packet loss
round-trip min = 3.69ms, avg = 3.69ms, max = 3.69ms, stddev = 0.000ms

[/]
A:admin@PE-1# ping 2001:db8::16:4:4 router-instance "CE-41" count 1
PING 2001:db8::16:4:4 56 data bytes
64 bytes from 2001:db8::16:4:4 icmp_seq=1 hlim=64 time=3.50ms.

---- 2001:db8::16:4:4 PING Statistics ----
1 packet transmitted, 1 packet received, 0.00% packet loss
round-trip min = 3.50ms, avg = 3.50ms, max = 3.50ms, stddev = 0.000ms

[/]
A:admin@PE-1# ping 172.16.5.54 router-instance "CE-51" count 1 # EVPN R-VPLS
PING 172.16.5.54 56 data bytes
64 bytes from 172.16.5.54: icmp_seq=1 ttl=64 time=3.63ms.

---- 172.16.5.54 PING Statistics ----
1 packet transmitted, 1 packet received, 0.00% packet loss
round-trip min = 3.63ms, avg = 3.63ms, max = 3.63ms, stddev = 0.000ms

[/]
A:admin@PE-1# ping 2001:db8::16:5:54 router-instance "CE-51" count 1
PING 2001:db8::16:5:54 56 data bytes
64 bytes from 2001:db8::16:5:54 icmp_seq=1 hlim=64 time=3.68ms.

---- 2001:db8::16:5:54 PING Statistics ----
1 packet transmitted, 1 packet received, 0.00% packet loss
round-trip min = 3.68ms, avg = 3.68ms, max = 3.68ms, stddev = 0.000ms
```

When **delete untrusted** is configured on the interface, the interface is trusted and the connectivity remains.

## Inter-AS option B services using untrusted interfaces with default-forwarding drop option

The following command on ASBR-2 configures the IP interface "int-ASBR-2-ASBR-3" as **untrusted** with **default-forwarding** argument set to **drop**:

```
# on ASBR-2:
configure {
  router "Base" {
    interface "int-ASBR-2-ASBR-3" {
      port 1/1/c1/1:1000
      ipv4 {
        primary {
          address 192.168.23.1
          prefix-length 30
        }
      }
      untrusted {
        default-forwarding drop
      }
    }
  }
}
```

When no **neighbor-trust** command is configured, the datapath drops all traffic for the configured services, as follows:

```
[/]
A:admin@PE-1# ping 10.1.4.4 router-instance "VPRN-1" count 1      # VPN-IPv4
PING 10.1.4.4 56 data bytes
Request timed out. icmp_seq=1.

---- 10.1.4.4 PING Statistics ----
1 packet transmitted, 0 packets received, 100% packet loss

[/]
A:admin@PE-1# ping 2001:db8::10:1:4:4 router-instance "VPRN-1" count 1
PING 2001:db8::10:1:4:4 56 data bytes
Request timed out. icmp_seq=1.

---- 2001:db8::10:1:4:4 PING Statistics ----
1 packet transmitted, 0 packets received, 100% packet loss

[/]
A:admin@PE-1# ping 10.2.4.4 router-instance "VPRN-2" count 1      # EVPN IFL
PING 10.2.4.4 56 data bytes
Request timed out. icmp_seq=1.

---- 10.2.4.4 PING Statistics ----
1 packet transmitted, 0 packets received, 100% packet loss

[/]
A:admin@PE-1# ping 2001:db8::10:2:4:4 router-instance "VPRN-2" count 1
PING 2001:db8::10:2:4:4 56 data bytes
Request timed out. icmp_seq=1.

---- 2001:db8::10:2:4:4 PING Statistics ----
1 packet transmitted, 0 packets received, 100% packet loss

[/]
A:admin@PE-1# ping 172.16.3.4 router-instance "CE-31" count 1      # EVPN VPLS
PING 172.16.3.4 56 data bytes
Request timed out. icmp_seq=1.
```



```

---- 172.16.3.4 PING Statistics ----
1 packet transmitted, 0 packets received, 100% packet loss

[/]
A:admin@PE-1# ping 2001:db8::16:3:4 router-instance "CE-31" count 1
PING 2001:db8::16:3:4 56 data bytes
112 bytes from 2001:db8::16:3:1 Address unreachable
VR CLS  LEN NXT HLIM SRC
 6 00   64 58   64 2001:db8::16:3:1
                               DST
                               2001:db8::16:3:4
ICMP6: Echo request

---- 2001:db8::16:3:4 PING Statistics ----
1 packet transmitted, 1 packet bounced, 0 packets received, 100% packet loss

[/]
A:admin@PE-1# ping 172.16.4.4 router-instance "CE-41" count 1 # EVPN VPWS
PING 172.16.4.4 56 data bytes
Request timed out. icmp_seq=1.

---- 172.16.4.4 PING Statistics ----
1 packet transmitted, 0 packets received, 100% packet loss

[/]
A:admin@PE-1# ping 2001:db8::16:4:4 router-instance "CE-41" count 1
PING 2001:db8::16:4:4 56 data bytes
112 bytes from 2001:db8::16:4:1 Address unreachable
VR CLS  LEN NXT HLIM SRC
 6 00   64 58   64 2001:db8::16:4:1
                               DST
                               2001:db8::16:4:4
ICMP6: Echo request

---- 2001:db8::16:4:4 PING Statistics ----
1 packet transmitted, 1 packet bounced, 0 packets received, 100% packet loss

[/]
A:admin@PE-1# ping 172.16.5.54 router-instance "CE-51" count 1 # EVPN R-VPLS
PING 172.16.5.54 56 data bytes
Request timed out. icmp_seq=1.

---- 172.16.5.54 PING Statistics ----
1 packet transmitted, 0 packets received, 100% packet loss

[/]
A:admin@PE-1# ping 2001:db8::16:5:54 router-instance "CE-51" count 1
PING 2001:db8::16:5:54 56 data bytes
112 bytes from 2001:db8::16:5:51 Address unreachable
VR CLS  LEN NXT HLIM SRC
 6 00   64 58   64 2001:db8::16:5:51
                               DST
                               2001:db8::16:5:54
ICMP6: Echo request

---- 2001:db8::16:5:54 PING Statistics ----
1 packet transmitted, 1 packet bounced, 0 packets received, 100% packet loss

```

When **neighbor-trust** is configured for the VPN-IPv4 address family, the datapath allows IPv4 traffic in VPRN-1 between PE-1 and PE-4 (but not traffic for services using the other address families):

```
# on ASBR-2:
```

```
configure {
  router "Base" {
    bgp {
      neighbor-trust {
        vpn-ipv4 true
      }
    }
  }
}
```

```
[/]
A:admin@PE-1# ping 10.1.4.4 router-instance "VPRN-1" count 1      # VPN-IPv4
PING 10.1.4.4 56 data bytes
64 bytes from 10.1.4.4: icmp_seq=1 ttl=64 time=2.77ms.
```

```
---- 10.1.4.4 PING Statistics ----
1 packet transmitted, 1 packet received, 0.00% packet loss
round-trip min = 2.77ms, avg = 2.77ms, max = 2.77ms, stddev = 0.000ms
```

```
[/]
A:admin@PE-1# ping 2001:db8::10:1:4:4 router-instance "VPRN-1" count 1
PING 2001:db8::10:1:4:4 56 data bytes
Request timed out. icmp_seq=1.
```

```
---- 2001:db8::10:1:4:4 PING Statistics ----
1 packet transmitted, 0 packets received, 100% packet loss
```

```
[/]
A:admin@PE-1# ping 10.2.4.4 router-instance "VPRN-2" count 1      # EVPN IFL
PING 10.2.4.4 56 data bytes
Request timed out. icmp_seq=1.
```

```
---- 10.2.4.4 PING Statistics ----
1 packet transmitted, 0 packets received, 100% packet loss
```

```
[/]
A:admin@PE-1# ping 2001:db8::10:2:4:4 router-instance "VPRN-2" count 1
PING 2001:db8::10:2:4:4 56 data bytes
Request timed out. icmp_seq=1.
```

```
---- 2001:db8::10:2:4:4 PING Statistics ----
1 packet transmitted, 0 packets received, 100% packet loss
```

```
[/]
A:admin@PE-1# ping 172.16.3.4 router-instance "CE-31" count 1      # EVPN VPLS
PING 172.16.3.4 56 data bytes
Request timed out. icmp_seq=1.
```

```
---- 172.16.3.4 PING Statistics ----
1 packet transmitted, 0 packets received, 100% packet loss
```

```
[/]
A:admin@PE-1# ping 2001:db8::16:3:4 router-instance "CE-31" count 1
PING 2001:db8::16:3:4 56 data bytes
112 bytes from 2001:db8::16:3:1 Address unreachable
VR CLS  LEN NXT HLIM SRC
 6 00   64 58   64 2001:db8::16:3:1
                               DST
                               2001:db8::16:3:4
```

```
ICMP6: Echo request
```

```
---- 2001:db8::16:3:4 PING Statistics ----
1 packet transmitted, 1 packet bounced, 0 packets received, 100% packet loss
```

```
[/]
A:admin@PE-1# ping 172.16.4.4 router-instance "CE-41" count 1      # EVPN VPWS
```

```

PING 172.16.4.4 56 data bytes
Request timed out. icmp_seq=1.

---- 172.16.4.4 PING Statistics ----
1 packet transmitted, 0 packets received, 100% packet loss

[/]
A:admin@PE-1# ping 172.16.5.54 router-instance "CE-51" count 1 # EVPN R-VPLS
PING 172.16.5.54 56 data bytes
Request timed out. icmp_seq=1.

---- 172.16.5.54 PING Statistics ----
1 packet transmitted, 0 packets received, 100% packet loss

[/]
A:admin@PE-1# ping 2001:db8::16:5:54 router-instance "CE-51" count 1
PING 2001:db8::16:5:54 56 data bytes
112 bytes from 2001:db8::16:5:51 Address unreachable
VR CLS  LEN NXT HLIM SRC
 6 00   64 58   64 2001:db8::16:5:51
                               DST
                               2001:db8::16:5:54
ICMP6: Echo request

---- 2001:db8::16:5:54 PING Statistics ----
1 packet transmitted, 1 packet bounced, 0 packets received, 100% packet loss
  
```

When **neighbor-trust** is configured for the VPN-IPv4 and VPN-IPv6 address families, the datapath allows IPv4 and IPv6 traffic in VPRN-1 between PE-1 and PE-4 (but not traffic for services using the EVPN address family):

```

# on ASBR-2:
configure {
  router "Base" {
    bgp {
      neighbor-trust {
        vpn-ipv4 true
        vpn-ipv6 true
      }
    }
  }
}
  
```

```

[/]
A:admin@PE-1# ping 10.1.4.4 router-instance "VPRN-1" count 1 # VPN-IPv4
PING 10.1.4.4 56 data bytes
64 bytes from 10.1.4.4: icmp_seq=1 ttl=64 time=2.78ms.

---- 10.1.4.4 PING Statistics ----
1 packet transmitted, 1 packet received, 0.00% packet loss
round-trip min = 2.78ms, avg = 2.78ms, max = 2.78ms, stddev = 0.000ms

[/]
A:admin@PE-1# ping 2001:db8::10:1:4:4 router-instance "VPRN-1" count 1
PING 2001:db8::10:1:4:4 56 data bytes
64 bytes from 2001:db8::10:1:4:4 icmp_seq=1 hlím=64 time=2.92ms.

---- 2001:db8::10:1:4:4 PING Statistics ----
1 packet transmitted, 1 packet received, 0.00% packet loss
round-trip min = 2.92ms, avg = 2.92ms, max = 2.92ms, stddev = 0.000ms

[/]
A:admin@PE-1# ping 10.2.4.4 router-instance "VPRN-2" count 1 # EVPN IFL
PING 10.2.4.4 56 data bytes
  
```

```
Request timed out. icmp_seq=1.

---- 10.2.4.4 PING Statistics ----
1 packet transmitted, 0 packets received, 100% packet loss

[/]
A:admin@PE-1# ping 2001:db8::10:2:4:4 router-instance "VPRN-2" count 1
PING 2001:db8::10:2:4:4 56 data bytes
Request timed out. icmp_seq=1.

---- 2001:db8::10:2:4:4 PING Statistics ----
1 packet transmitted, 0 packets received, 100% packet loss

[/]
A:admin@PE-1# ping 172.16.3.4 router-instance "CE-31" count 1 # EVPN VPLS
PING 172.16.3.4 56 data bytes
Request timed out. icmp_seq=1.

---- 172.16.3.4 PING Statistics ----
1 packet transmitted, 0 packets received, 100% packet loss

[/]
A:admin@PE-1# ping 2001:db8::16:3:4 router-instance "CE-31" count 1
PING 2001:db8::16:3:4 56 data bytes
112 bytes from 2001:db8::16:3:1 Address unreachable
VR CLS  LEN NXT HLIM SRC
 6 00   64 58   64 2001:db8::16:3:1
                               DST
                               2001:db8::16:3:4
ICMP6: Echo request

---- 2001:db8::16:3:4 PING Statistics ----
1 packet transmitted, 1 packet bounced, 0 packets received, 100% packet loss

[/]
A:admin@PE-1# ping 172.16.4.4 router-instance "CE-41" count 1 # EVPN VPWS
PING 172.16.4.4 56 data bytes
Request timed out. icmp_seq=1.

---- 172.16.4.4 PING Statistics ----
1 packet transmitted, 0 packets received, 100% packet loss

[/]
A:admin@PE-1# ping 2001:db8::16:4:4 router-instance "CE-41" count 1
PING 2001:db8::16:4:4 56 data bytes
112 bytes from 2001:db8::16:4:1 Address unreachable
VR CLS  LEN NXT HLIM SRC
 6 00   64 58   64 2001:db8::16:4:1
                               DST
                               2001:db8::16:4:4
ICMP6: Echo request

---- 2001:db8::16:4:4 PING Statistics ----
1 packet transmitted, 1 packet bounced, 0 packets received, 100% packet loss

[/]
A:admin@PE-1# ping 172.16.5.54 router-instance "CE-51" count 1 # EVPN R-VPLS
PING 172.16.5.54 56 data bytes
Request timed out. icmp_seq=1.

---- 172.16.5.54 PING Statistics ----
1 packet transmitted, 0 packets received, 100% packet loss

[/]
```

```
A:admin@PE-1# ping 2001:db8::16:5:54 router-instance "CE-51" count 1
PING 2001:db8::16:5:54 56 data bytes
112 bytes from 2001:db8::16:5:51 Address unreachable
VR CLS  LEN NXT HLIM SRC
 6 00   64 58   64 2001:db8::16:5:51
                               DST
                               2001:db8::16:5:54
ICMP6: Echo request

---- 2001:db8::16:5:54 PING Statistics ----
1 packet transmitted, 1 packet bounced, 0 packets received, 100% packet loss
```

When **neighbor-trust** is configured for the EVPN address family only, the datapath allows traffic in VPRN-2, VPLS-3, Epipe-4, and EVPN R-VPLS BD-5 between PE-1 and PE-4, but not in IP-VPN VPRN-1 (which does not use the EVPN address family):

```
# on ASBR-2:
configure {
  router "Base" {
    bgp {
      neighbor-trust {
        vpn-ipv4 false
        vpn-ipv6 false
        evpn true
      }
    }
  }
}
```

```
[/]
A:admin@PE-1# ping 10.1.4.4 router-instance "VPRN-1" count 1      # VPN-IPv4
PING 10.1.4.4 56 data bytes
Request timed out. icmp_seq=1.

---- 10.1.4.4 PING Statistics ----
1 packet transmitted, 0 packets received, 100% packet loss

[/]
A:admin@PE-1# ping 2001:db8::10:1:4:4 router-instance "VPRN-1" count 1
PING 2001:db8::10:1:4:4 56 data bytes
Request timed out. icmp_seq=1.

---- 2001:db8::10:1:4:4 PING Statistics ----
1 packet transmitted, 0 packets received, 100% packet loss

[/]
A:admin@PE-1# ping 10.2.4.4 router-instance "VPRN-2" count 1      # EVPN IFL
PING 10.2.4.4 56 data bytes
64 bytes from 10.2.4.4: icmp_seq=1 ttl=64 time=3.00ms.

---- 10.2.4.4 PING Statistics ----
1 packet transmitted, 1 packet received, 0.00% packet loss
round-trip min = 3.00ms, avg = 3.00ms, max = 3.00ms, stddev = 0.000ms

[/]
A:admin@PE-1# ping 2001:db8::10:2:4:4 router-instance "VPRN-2" count 1
PING 2001:db8::10:2:4:4 56 data bytes
64 bytes from 2001:db8::10:2:4:4 icmp_seq=1 hlim=64 time=2.75ms.

---- 2001:db8::10:2:4:4 PING Statistics ----
1 packet transmitted, 1 packet received, 0.00% packet loss
round-trip min = 2.75ms, avg = 2.75ms, max = 2.75ms, stddev = 0.000ms

[/]
```

```

A:admin@PE-1# ping 172.16.3.4 router-instance "CE-31" count 1 # EVPN VPLS
PING 172.16.3.4 56 data bytes
64 bytes from 172.16.3.4: icmp_seq=1 ttl=64 time=3.89ms.

---- 172.16.3.4 PING Statistics ----
1 packet transmitted, 1 packet received, 0.00% packet loss
round-trip min = 3.89ms, avg = 3.89ms, max = 3.89ms, stddev = 0.000ms

[/]
A:admin@PE-1# ping 2001:db8::16:3:4 router-instance "CE-31" count 1
PING 2001:db8::16:3:4 56 data bytes
64 bytes from 2001:db8::16:3:4 icmp_seq=1 hlim=64 time=3.95ms.

---- 2001:db8::16:3:4 PING Statistics ----
1 packet transmitted, 1 packet received, 0.00% packet loss
round-trip min = 3.95ms, avg = 3.95ms, max = 3.95ms, stddev = 0.000ms

[/]
A:admin@PE-1# ping 172.16.4.4 router-instance "CE-41" count 1 # EVPN VPWS
PING 172.16.4.4 56 data bytes
64 bytes from 172.16.4.4: icmp_seq=1 ttl=64 time=3.87ms.

---- 172.16.4.4 PING Statistics ----
1 packet transmitted, 1 packet received, 0.00% packet loss
round-trip min = 3.87ms, avg = 3.87ms, max = 3.87ms, stddev = 0.000ms

[/]
A:admin@PE-1# ping 2001:db8::16:4:4 router-instance "CE-41" count 1
PING 2001:db8::16:4:4 56 data bytes
64 bytes from 2001:db8::16:4:4 icmp_seq=1 hlim=64 time=3.86ms.

---- 2001:db8::16:4:4 PING Statistics ----
1 packet transmitted, 1 packet received, 0.00% packet loss
round-trip min = 3.86ms, avg = 3.86ms, max = 3.86ms, stddev = 0.000ms

[/]
A:admin@PE-1# ping 172.16.5.54 router-instance "CE-51" count 1 # EVPN R-VPLS
PING 172.16.5.54 56 data bytes
64 bytes from 172.16.5.54: icmp_seq=1 ttl=64 time=3.88ms.

---- 172.16.5.54 PING Statistics ----
1 packet transmitted, 1 packet received, 0.00% packet loss
round-trip min = 3.88ms, avg = 3.88ms, max = 3.88ms, stddev = 0.000ms

[/]
A:admin@PE-1# ping 2001:db8::16:5:54 router-instance "CE-51" count 1
PING 2001:db8::16:5:54 56 data bytes
64 bytes from 2001:db8::16:5:54 icmp_seq=1 hlim=64 time=3.70ms.

---- 2001:db8::16:5:54 PING Statistics ----
1 packet transmitted, 1 packet received, 0.00% packet loss
round-trip min = 3.70ms, avg = 3.70ms, max = 3.70ms, stddev = 0.000ms
  
```

## Inter-AS option B label security with services configured on PEs and on ASBR

BGP neighbor trust is not supported on PE-ASBRs for VPLS or Epipe services, as shown for ASBR-2 in the following example. [Figure 20: Example topology with services on PEs and on ASBR-2](#) shows the topology with services on ASBR-2 as well as on the PEs.

Figure 20: Example topology with services on PEs and on ASBR-2

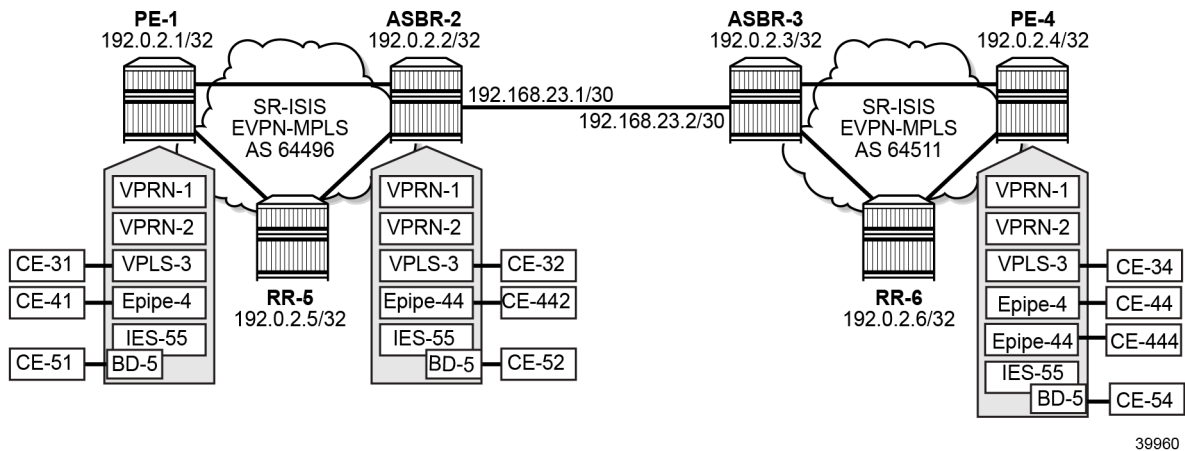

The service configuration on ASBR-2 is similar to the service configuration on PE-1 and PE-4. Epipes-44 is an Epipes between ASBR-2 and PE-4, but the other services are the same as in the PEs. The interface between ASBR-2 and ASBR-3 remains untrusted with **default-forwarding** set to **drop**. The **neighbor-trust** command on ASBR-2 is configured for VPN-IPv4, VPN-IPv6, and EVPN, as follows:

```
# on ASBR-2:
configure {
  router "Base" {
    bgp {
      neighbor-trust {
        vpn-ipv4 true
        vpn-ipv6 true
        evpn true
      }
    }
  }
}
```

The datapath allows traffic for the VPRN services on ASBR-2 and PE-4 (using VPN-IPv4, VPN-IPv6, or EVPN-IFL), but the traffic between the EVPN VPLS and EVPN VPWS services on ASBR-2 and PE-4 is dropped, as follows:

```
[/]
A:admin@ASBR-2# ping 10.1.4.4 router-instance "VPRN-1" count 1 # VPN-IPv4
PING 10.1.4.4 56 data bytes
64 bytes from 10.1.4.4: icmp_seq=1 ttl=64 time=2.66ms.

---- 10.1.4.4 PING Statistics ----
1 packet transmitted, 1 packet received, 0.00% packet loss
round-trip min = 2.66ms, avg = 2.66ms, max = 2.66ms, stddev = 0.000ms

[/]
A:admin@ASBR-2# ping 2001:db8::10:1:4:4 router-instance "VPRN-1" count 1
PING 2001:db8::10:1:4:4 56 data bytes
64 bytes from 2001:db8::10:1:4:4 icmp_seq=1 hlim=64 time=2.27ms.

---- 2001:db8::10:1:4:4 PING Statistics ----
1 packet transmitted, 1 packet received, 0.00% packet loss
round-trip min = 2.27ms, avg = 2.27ms, max = 2.27ms, stddev = 0.000ms

[/]
A:admin@ASBR-2# ping 10.2.4.4 router-instance "VPRN-2" count 1 # EVPN IFL
```

```

PING 10.2.4.4 56 data bytes
64 bytes from 10.2.4.4: icmp_seq=1 ttl=64 time=2.42ms.

---- 10.2.4.4 PING Statistics ----
1 packet transmitted, 1 packet received, 0.00% packet loss
round-trip min = 2.42ms, avg = 2.42ms, max = 2.42ms, stddev = 0.000ms

[/]
A:admin@ASBR-2# ping 2001:db8::10:2:4:4 router-instance "VPRN-2" count 1
PING 2001:db8::10:2:4:4 56 data bytes
64 bytes from 2001:db8::10:2:4:4 icmp_seq=1 hlim=64 time=2.31ms.

---- 2001:db8::10:2:4:4 PING Statistics ----
1 packet transmitted, 1 packet received, 0.00% packet loss
round-trip min = 2.31ms, avg = 2.31ms, max = 2.31ms, stddev = 0.000ms

[/]
A:admin@ASBR-2# ping 172.16.3.4 router-instance "CE-32" count 1      # EVPN VPLS
PING 172.16.3.4 56 data bytes
Request timed out. icmp_seq=1.

---- 172.16.3.4 PING Statistics ----
1 packet transmitted, 0 packets received, 100% packet loss

[/]
A:admin@ASBR-2# ping 2001:db8::16:3:4 router-instance "CE-32" count 1
PING 2001:db8::16:3:4 56 data bytes
112 bytes from 2001:db8::16:3:2 Address unreachable
VR CLS  LEN NXT HLIM SRC
 6 00   64 58   64 2001:db8::16:3:2
                               DST
                               2001:db8::16:3:4
ICMP6: Echo request

---- 2001:db8::16:3:4 PING Statistics ----
1 packet transmitted, 1 packet bounced, 0 packets received, 100% packet loss

[/]
A:admin@ASBR-2# ping 172.16.44.4 router-instance "CE-442" count 1   # EVPN VPWS
PING 172.16.44.4 56 data bytes
Request timed out. icmp_seq=1.

---- 172.16.44.4 PING Statistics ----
1 packet transmitted, 0 packets received, 100% packet loss

[/]
A:admin@ASBR-2# ping 2001:db8::16:44:4 router-instance "CE-442" count 1
PING 2001:db8::16:44:4 56 data bytes
112 bytes from 2001:db8::16:44:2 Address unreachable
VR CLS  LEN NXT HLIM SRC
 6 00   64 58   64 2001:db8::16:44:2
                               DST
                               2001:db8::16:44:4
ICMP6: Echo request

---- 2001:db8::16:44:4 PING Statistics ----
1 packet transmitted, 1 packet bounced, 0 packets received, 100% packet loss

[/]
A:admin@ASBR-2# ping 172.16.5.54 router-instance "CE-52" count 1   # EVPN R-VPLS
PING 172.16.5.54 56 data bytes
Request timed out. icmp_seq=1.

---- 172.16.5.54 PING Statistics ----

```



```
1 packet transmitted, 0 packets received, 100% packet loss

[/]
A:admin@ASBR-2# ping 2001:db8::16:5:54 router-instance "CE-52" count 1
PING 2001:db8::16:5:54 56 data bytes
112 bytes from 2001:db8::16:5:52 Address unreachable
VR CLS  LEN NXT HLIM SRC
 6 00   64 58   64 2001:db8::16:5:52
                               DST
                               2001:db8::16:5:54
ICMP6: Echo request

---- 2001:db8::16:5:54 PING Statistics ----
1 packet transmitted, 1 packet bounced, 0 packets received, 100% packet loss
```

The datapath allows traffic between PE-1 and PE-4 for all services, but drops the traffic to and from the local EVPN VPLS and EVPN VPWS on the ASBR. BGP neighbor trust is not supported for EVPN-IFF routes on a PE-ASBR.

## Conclusion

BGP neighbor trust prevents label spoofing in inter-AS option B for the VPN-IPv4, VPN-IPv6, and EVPN address families.

# Network Group Encryption Helper

This chapter describes the network group encryption (NGE) helper.

Topics in this chapter include:

- [Applicability](#)
- [Overview](#)
- [Configuration](#)
- [Conclusion](#)

## Applicability

The information and configuration in this chapter are based on SR OS Release 23.3.R1. Network group encryption (NGE) helpers require use of the VSR-a or the VSR-I and can be deployed with 7750 SR and 7950 XRS.

## Overview

The NGE helper enables NGE security for services configured on the 7750 SR or 7950 XRS (hereafter referred to as the router) that require additional confidentiality and integrity.

Multiple NGE helpers can be deployed with a router depending on the encrypted services throughput requirements required by the operator. [Figure 21: General architecture using an NGE helper](#) shows the general architecture using an NGE helper.

Figure 21: General architecture using an NGE helper

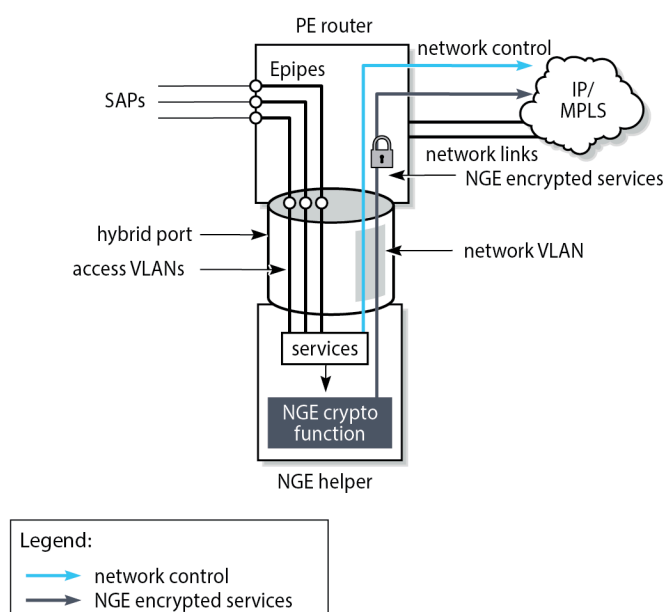

37325

Each NGE helper is connected to the router using an access interface and a network interface, where both interfaces are configured on the NGE helper and on the router. A hybrid port can be used on the router and NGE helper to optimize the deployment, so one physical port is required on the router and NGE helper.

SAPs are configured on the router using an Epipe directed toward the NGE helper access interface. Unencrypted traffic that is received on the SAP interface is sent through the Epipe to the NGE helper which encrypts the traffic before sending it toward the network. The network interface on the NGE helper is enabled with minimal network control plane functions toward the router. The network control plane of the router performs the majority of network level processing and forwarding of NGE encrypted services.

The NGE helper supports services-based encryption, including:

- VPRN encryption
- SDP encryption
- PW-template encryption



**Note:** In SR OS Release 23.3.R1, all services-based encryption can be configured in classic CLI, whereas in MD-CLI, only PW-template encryption can be configured.

Router interface encryption and port-level encryption are not supported by the NGE helper.

## Scenarios for encrypting services

The following main services scenarios are supported:

- **VPRN encryption using auto-bind services for both MPLS (LDP or RSVP-TE signaled tunnels) and GRE transport**

This scenario uses BGP to advertise the NGE helper IP address to remote NGE helpers. Remote NGE helpers can then send VPRN traffic to other NGE helpers to be processed for the associated destination SAP. This scenario uses VPRN-level NGE.

- **NG-MVPN with VPRN encryption using MLDP tunnels from the NGE helper to the router**

This scenario uses a similar setup to VPRN encryption, with the difference that MLDP tunnels are also established between the NGE helper and the router where the point-to-multipoint tree branches from for the NG-MVPN service. This scenario uses VPRN-level NGE.

- **T-LDP signaled Epipe or VPLS services using LDP or RSVP-TE transport tunnels**

T-LDP sessions are established from the NGE helper to the remote PEs to establish Epipe or VPLS services. The transport of these services focuses on LDP or LDP with RSVP-TE. Where GRE is possible, GRE support of VPLS or VPWS mainly uses BGP VPLS or BGP VPWS with auto-GRE SDP, because this use case is prevalent with SAR-Hm/Hmc deployments. This scenario uses SDP-level NGE.

- **L2 services using BGP VPLS or BGP VPWS auto-GRE SDP**

This scenario is similar to the VPRN auto-bind scenario, except that a BGP session is used to advertise L2 routes to and from the NGE helper where remote PEs can send GRE L2 packets encrypted with the associated NGE configuration under the **pw-template** context.

## Configuration

### NGE configuration

NGE configuration is managed by the Network Services Platform Network Functions Manager - Packet (NSP NFM-P). Operators use the NSP NFM-P to configure:

- global encryption labels
- key groups
- VPRN-level encryption – setting the inbound and outbound key groups on VPRN-based services
- SDP-level encryption – setting the inbound and outbound key groups on selected SDPs
- PW-template level encryption – setting the inbound and outbound key groups on selected PW templates



**Note:** In this chapter, the NSP NFM-P is not used. Therefore, the remainder of the chapter focuses on PW-template level encryption, that can be configured in MD-CLI in SR OS Release 23.3.R1.

### Group encryption configuration

In this example, encryption keygroup 1 is configured manually on NGE-1:

```
# on NGE-1:
configure {
  group-encryption {
    group-encryption-label 100
    encryption-keygroup 1 {
```

```

keygroup-name "KG1"
active-outbound-security-association 1
security-association 1 {
  authentication-key
0x1111111100000000111111110000000011111111000000001111111100000000
  encryption-key 0x11111111000000001111111100000000
}
security-association 2 {
  authentication-key
0x2222222200000000222222220000000022222222000000002222222200000000
  encryption-key 0x22222222000000002222222200000000
}
security-association 3 {
  authentication-key
0x3333333300000000333333330000000033333333000000003333333300000000
  encryption-key 0x33333333000000003333333300000000
}
security-association 4 {
  authentication-key
0x4444444400000000444444440000000044444444000000004444444400000000
  encryption-key 0x44444444000000004444444400000000
}
}

```

The authentication key and the encryption key are configured as cleartext. After configuration, they are never displayed in their cleartext form. The security parameter index (SPI) value in the security association is a node-wide unique value.

## PW-template configuration

On NGE-1, PW template 2 is configured with encryption keygroup 1:

```

# on NGE-1:
service {
  pw-template "2" {
    auto-gre-sdp true
    vc-type vlan
    split-horizon-group {
      name "SHG"
    }
    encryption-keygroup {
      inbound 1
      outbound 1
    }
  }
}

```

## BGP configuration

BGP must be enabled on the router and the NGE helper for the L2-VPN address family for the following services:

- BGP VPWS with auto-GRE SDP (where NGE is configured under the **pw-template** context)
- BGP VPLS with auto-GRE SDP (where NGE is configured under the **pw-template** context)

[Figure 22: BGP topology for learning BGP label routes](#) shows the BGP topology for learning BGP label routes for those services.

Figure 22: BGP topology for learning BGP label routes

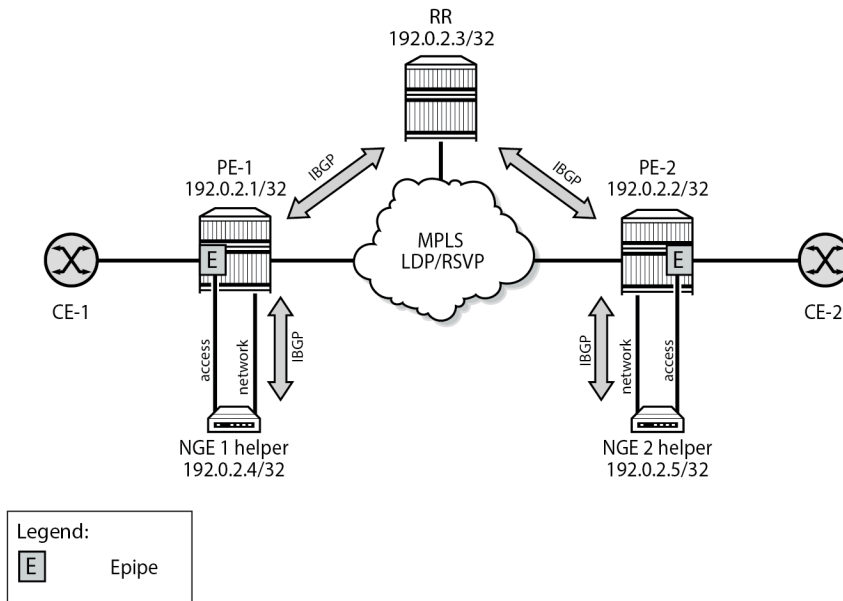

37326

The following configures BGP on PE-1 to support the NGE 1 helper function:

```
# on PE-1:
configure {
  router "Base" {
    bgp {
      rapid-withdrawal true
      group "PE-1-NGE-1-RR" {
        peer-as 64496
        family {
          l2-vpn true
        }
      }
      cluster {
        cluster-id 192.0.2.1
      }
    }
    group "core-RR" {
      peer-as 64496
      family {
        l2-vpn true
      }
    }
    neighbor "192.0.2.3" {
      group "core-RR"
    }
    neighbor "192.0.2.4" {
      group "PE-1-NGE-1-RR"
    }
  }
}
```

The following configures BGP on PE-2 to support the NGE 2 helper function:

```
# on PE-2:
configure {
```

```
router "Base" {
  bgp {
    rapid-withdrawal true
    group "PE-2-NGE-2-RR" {
      peer-as 64496
      family {
        l2-vpn true
      }
      cluster {
        cluster-id 192.0.2.2
      }
    }
    group "core-RR" {
      peer-as 64496
      family {
        l2-vpn true
      }
    }
    neighbor "192.0.2.3" {
      group "core-RR"
    }
    neighbor "192.0.2.5" {
      group "PE-2-NGE-2-RR"
    }
  }
}
```

The BGP configuration on the NGE-1 helper is as follows:

```
# on NGE-1:
configure {
  router "Base" {
    bgp {
      rapid-withdrawal true
      group "RR-PE-1" {
        peer-as 64496
        family {
          l2-vpn true
        }
      }
      neighbor "192.0.2.1" {
        group "RR-PE-1"
      }
    }
  }
}
```

The BGP configuration on the NGE-2 helper is as follows:

```
# on NGE-2:
configure {
  router "Base" {
    bgp {
      rapid-withdrawal true
      group "RR-PE-2" {
        peer-as 64496
        family {
          l2-vpn true
        }
      }
      neighbor "192.0.2.2" {
        group "RR-PE-2"
      }
    }
  }
}
```

## Services configuration

### BGP VPLS or BGP VPWS with auto-GRE SDP

Figure 23: NGE helper for BGP VPLS or BGP VPWS using GRE SDPs with auto-GRE SDP shows the operation of the NGE helper for BGP VPLS and BGP VPWS services that use GRE SDPs when auto-GRE SDP is configured on the associated PW template.

Figure 23: NGE helper for BGP VPLS or BGP VPWS using GRE SDPs with auto-GRE SDP

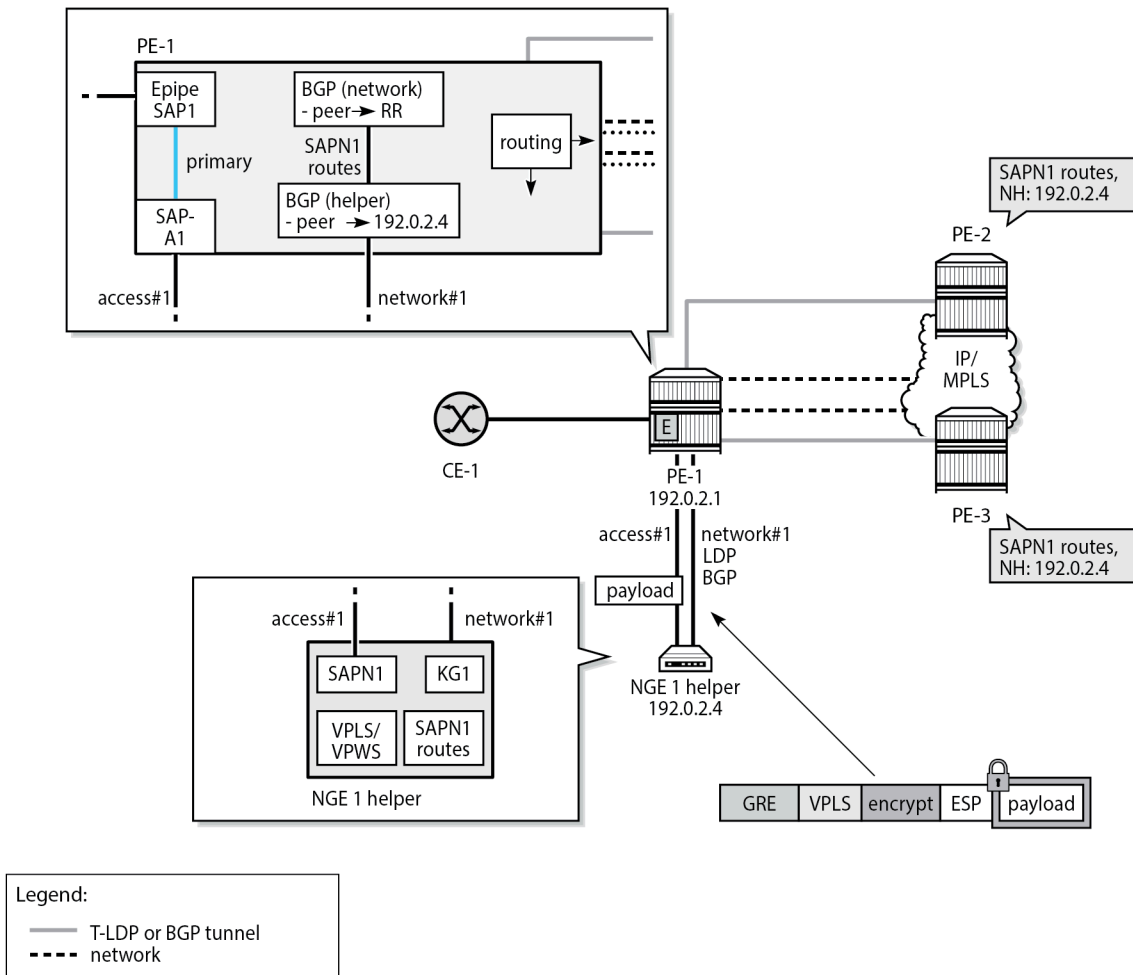

37329

In this scenario, the VPLS or VPWS SAPN1 is configured on the NGE-1 helper. On PE-1, a local Epipe is configured that originates from the customer facing SAP1 and terminates on SAP-A1 connected to the NGE-1 helper. On PE-1, Epipes 100101 and 100201 are configured as follows:

```
# on PE-1:
configure {
```



```

service {
  epipe "Epipe-100101" {
    admin-state enable
    service-id 100101
    customer "1"
    sap lag-1:101 {
      description "toward NGE-1 Epipe 101"
    }
    sap lag-11:101.1 {
      description "toward CE"
    }
  }
  epipe "Epipe-100201" {
    admin-state enable
    service-id 100201
    customer "1"
    sap lag-1:201 {
      description "toward NGE-1 VPLS 201"
    }
    sap lag-11:201.1 {
      description "toward CE"
    }
  }
}

```

On PE-1, the following network configurations are required to support encrypted services from the NGE-1 helper:

- any routing options that allow GRE packets received from the NGE helper to be routed to remote PEs
- BGP sessions for the L2-VPN address family, as described in the [BGP configuration](#) section

On the NGE-1 helper, the configuration includes:

- VPLS or VPWS SAPN1
- BGP session to PE-1 for the L2-VPN address family
- BGP VPLS or BGP VPWS using PW templates with auto-GRE SDP enabled
- NGE enabled on the PW templates for encrypting the VPLS or VPWS services using the PW templates

On NGE-1, Epipe 101 is a BGP VPWS with auto-GRE SDP. PW template 2 is configured with encryption keygroup 1. Epipe 101 is configured as follows:

```

# on NGE-1:
configure {
  service {
    pw-template "2" {
      auto-gre-sdp true
      vc-type vlan
      split-horizon-group {
        name "SHG"
      }
      encryption-keygroup {
        inbound 1
        outbound 1
      }
    }
  }
  epipe "Epipe-101" {
    admin-state enable
    description "BGP VPWS auto-gre SDP_PW template 2"
    service-id 101
    customer "1"
    bgp 1 {
      route-distinguisher "101:1"
    }
  }
}

```

```

    route-target {
        export "target:101:1"
        import "target:101:1"
    }
    pw-template-binding "2" {
    }
}
bgp-vpws {
    admin-state enable
    local-ve {
        name "pe-1"
        id 1
    }
    remote-ve "pe-2" {
        id 2
    }
}
sap lag-1:101 {
}
}

```

In a similar way, VPLS 201 is a BGP VPLS with auto-GRE SDP. PW template 2 is configured with encryption keygroup 1. VPLS 201 is configured as follows:

```

# on NGE-1:
configure {
    service {
        vpls "VPLS-201" {
            admin-state enable
            description "BGP VPLS auto-gre SDP_PW template 2"
            service-id 201
            customer "1"
            bgp 1 {
                route-distinguisher "201:1"
                route-target {
                    export "target:201:1"
                    import "target:201:1"
                }
                pw-template-binding "2" {
                }
            }
        }
        bgp-vpls {
            admin-state enable
            maximum-ve-id 10
            ve {
                name "pe-1"
                id 1
            }
        }
        sap lag-1:201 {
        }
    }
}

```

## Verification

The following base information for the services shows that the services are operationally up, as well as their SAPs and SDP bindings:

```

[/]
A:admin@NGE-1# show service id 101 base

```

```

=====
Service Basic Information
=====
Service Id       : 101                Vpn Id           : 0
Service Type     : Epipe
MACSec enabled   : no
Name             : Epipe-101
Description      : BGP VPWS auto-gre SDP_PW template 2
Customer Id     : 1                  Creation Origin  : manual
Last Status Change: 03/31/2023 15:44:58
Last Mgmt Change : 03/31/2023 15:44:58
Test Service     : No
Admin State      : Up                Oper State       : Up
---snip---
  
```

```

-----
Service Access & Destination Points
-----
Identifier                Type      AdmMTU  OprMTU  Adm  Opr
-----
sap:lag-1:101             q-tag    8936    8936    Up   Up
sdp:32767:4294967295 SB(192.0.2.5) BgpVpws  0       8890    Up   Up
=====
  
```

```

[/]
A:admin@NGE-1# show service id 201 base
  
```

```

=====
Service Basic Information
=====
Service Id       : 201                Vpn Id           : 0
Service Type     : VPLS
MACSec enabled   : no
Name             : VPLS-201
Description      : BGP VPLS auto-gre SDP_PW template 2
Customer Id     : 1                  Creation Origin  : manual
Last Status Change: 03/31/2023 15:42:13
Last Mgmt Change : 03/31/2023 15:44:58
Etree Mode      : Disabled
Admin State      : Up                Oper State       : Up
MTU              : 1514
SAP Count       : 1                  SDP Bind Count   : 1
---snip---
  
```

```

-----
Service Access & Destination Points
-----
Identifier                Type      AdmMTU  OprMTU  Adm  Opr
-----
sap:lag-1:201             q-tag    8936    8936    Up   Up
sdp:32766:4294967294 SB(192.0.2.5) BgpVpls  0       8890    Up   Up
=====
  
```

The following command shows the encryption keygroup 1 with the associated SDPs: SDP 32767 is auto-provisioned by BGP-VPWS in Epipe 101, and SDP 32766 by BGP-VPLS in VPLS 201.

```

[/]
A:admin@NGE-1# show group-encryption encryption-keygroup 1
  
```

```

=====
Encryption Keygroup Configuration Detail
=====
  
```

```

Keygroup Id      : 1
Keygroup Name    : KG1
Description      : None
Authentication Algo: sha256
Encryption Algo  : aes128
Active Outbound SA : 1
Activation Time  : 03/31/2023 15:42:12
  
```

-----  
 Security Associations  
 -----

```

Spi              : 1
Install Time     : 03/31/2023 15:42:12
Key CRC          : 0xf57dcffc

Spi              : 2
Install Time     : 03/31/2023 15:42:12
Key CRC          : 0x26134d07

Spi              : 3
Install Time     : 03/31/2023 15:42:12
Key CRC          : 0xde19ce91

Spi              : 4
Install Time     : 03/31/2023 15:42:12
Key CRC          : 0x5bbf4eb0
  
```

-----  
 Encryption Keygroup Forwarded Statistics  
 -----

```

Encrypted Pkts   : 22           Encrypted Bytes   : 2124
Decrypted Pkts   : 22           Decrypted Bytes   : 2124
  
```

-----  
 Encryption Keygroup Outbound Discarded Statistics (Pkts)  
 -----

```

Total Discard    : 0           Other              : 0
  
```

-----  
 Encryption Keygroup Inbound Discarded Statistics (Pkts)  
 -----

```

Total Discard    : 0           Invalid Spi        : 0
Authentication Failure *: 0       Padding Error      : 0
Other            : 0
  
```

-----  
 SDP Keygroup Association Table  
 -----

SDP ID	Direction	
	Inbound	Outbound
32766	Inbound	Outbound
32767	Inbound	Outbound

```

Inbound Keygroup SDP Association Count: 2
Outbound Keygroup SDP Association Count: 2
  
```

-----  
 VPRN Keygroup Association Table  
 -----

No entries found

-----  
 Network Interface Association Table  
 -----

No entries found

```
-----  
Wlan-GW Keygroup Association Table  
-----
```

```
No entries found
```

```
=====  
* indicates that the corresponding row element may have been truncated.
```

## Conclusion

NGE is a security solution for encrypting traffic flows on a per-service basis. The NGE helper extends the NGE solution to 7750 SR and 7950 XRS platforms where larger core and PE nodes are required to participate with other NGE-capable nodes.

# Seamless BFD Application — Auto-bind tunnel

This chapter provides information about seamless BFD application — auto-bind tunnel.

Topics in this chapter include:

- [Applicability](#)
- [Overview](#)
- [Configuration](#)
- [Conclusion](#)

## Applicability

This chapter was initially written based on SR OS Release 19.10.R3, but the MD-CLI in the current edition corresponds to SR OS Release 23.3.R3.

A prerequisite is to read the "Seamless BFD for SR-TE LSPs" chapter in the *7750 SR and 7950 XRS Segment Routing and PCE Advanced Configuration Guide for MD CLI*.

## Overview

Bidirectional forwarding detection (BFD) is widely deployed in IP/MPLS networks to rapidly detect failures in the forwarding path between network elements.

Seamless BFD (S-BFD) is described in RFC 7880. S-BFD minimizes the time required to establish BFD sessions by removing the discovery of discriminators during the initial handshaking procedure, which contributes to its seamless operation. S-BFD relies on the fact that the discriminators needed to establish the BFD session are already known by the endpoints for each session, either through configuration or advertisement using unicast protocols.

[Figure 24: S-BFD session establishment – continuity check](#) shows the S-BFD session establishment between PE-1 and PE-4. The BFD discriminator used by the initiator is chosen by the system. On PE-1, the BFD (initiator) discriminator equals 123; on PE-4, the S-BFD (reflector) discriminator equals 524288. Through IGP advertisement or configuration, head-end router PE-1 is aware of the S-BFD discriminator of PE-4 (system ID 192.0.2.4; S-BFD discriminator 524288).

Figure 24: S-BFD session establishment – continuity check

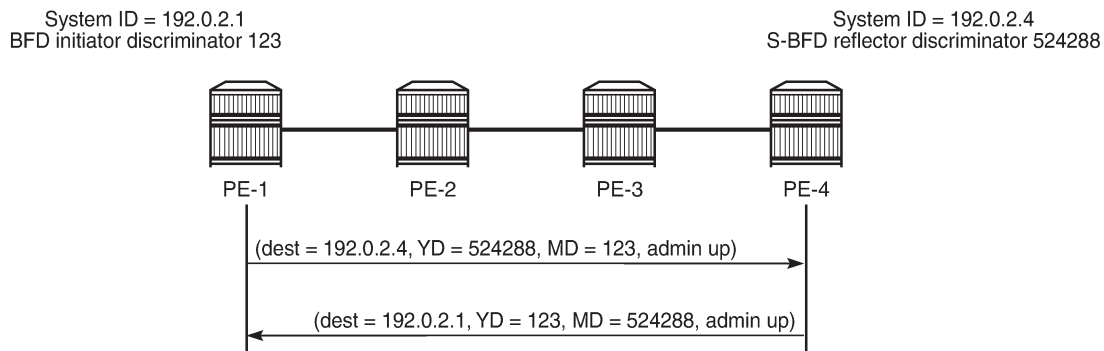

35629

The state of the SR-TE LSP is linked to the state of the S-BFD session when failure action **failover-or-down** is configured. In the "Seamless BFD for SR-TE LSPs" chapter in the *7750 SR and 7950 XRS Segment Routing and PCE Advanced Configuration Guide for MD CLI*, one of the examples illustrates the use of S-BFD with failure action **failover-or-down** in an SR-TE LSP with a primary path and a standby secondary path. When a link or node fails on the primary path, the S-BFD session goes down and the head-end node switches to a standby path that is operationally up.

In this chapter, S-BFD is configured in an SR-TE LSP with primary path only. Services such as VPRNs or EVPNs may have auto-bind tunnel configured with multiple tunnel resolution protocols, such as SR-TE and SR-ISIS. SR-TE tunnels are preferred to SR-ISIS tunnels. When a link or node fails on the primary path, the S-BFD session goes operationally down and the SR-TE LSP goes operationally down, and is removed from the tunnel table. The head-end node reverts to the best preference tunnel that is up; in this case, an SR-ISIS tunnel.

## Configuration

Figure 25: [Example topology](#) shows the example topology. The VPRN and EVPN services will be configured on PE-2 and PE-5.

Figure 25: Example topology

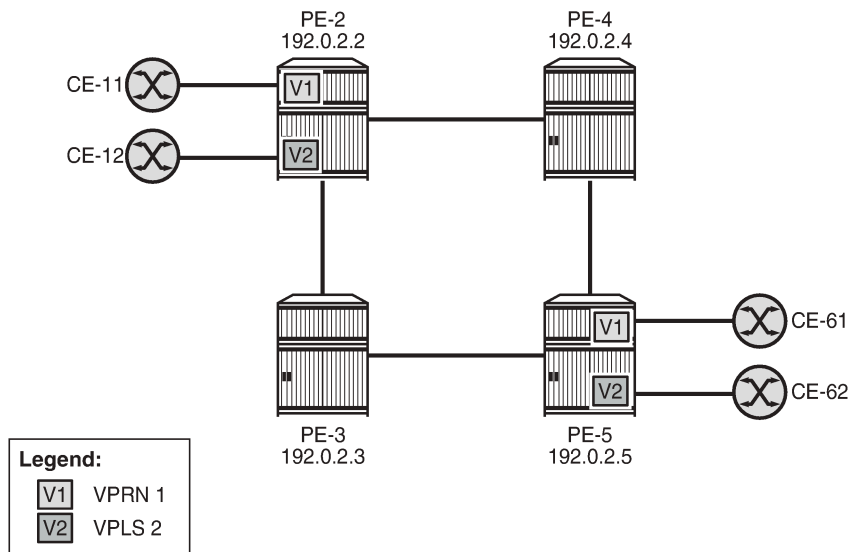

35836

## Initial configuration

The initial configuration on the PEs includes:

- Cards, MDAs, ports
- Router interfaces
- IS-IS as IGP (alternatively, OSPF can be used)
- SR-ISIS enabled
- Traffic engineering enabled on PE-2 and PE-5

The initial configuration on PE-2 is as follows:

```
# on PE-2:
configure {
  router "Base" {
    interface "int-PE-2-PE-3" {
      port 1/1/c2/1:1000
      ipv4 {
        primary {
          address 192.168.23.1
          prefix-length 30
        }
      }
    }
    interface "int-PE-2-PE-4" {
      port 1/1/c1/1:1000
      ipv4 {
        primary {
          address 192.168.24.1
          prefix-length 30
        }
      }
    }
  }
}
```



```

    }
  }
  interface "system" {
    ipv4 {
      primary {
        address 192.0.2.2
        prefix-length 32
      }
    }
  }
  mpls-labels {
    sr-labels {
      start 32000
      end 32999
    }
  }
  isis 0 {
    admin-state enable
    advertise-router-capability area
    traffic-engineering true
    area-address [49.0001]
    segment-routing {
      admin-state enable
      prefix-sid-range {
        global
      }
    }
  }
  interface "int-PE-2-PE-3" {
    interface-type point-to-point
  }
  interface "int-PE-2-PE-4" {
    interface-type point-to-point
  }
  interface "system" {
    ipv4-node-sid {
      index 2
    }
  }
}

```

## S-BFD configuration

For S-BFD, the reflector BFD discriminator values must be configured in the range from 524288 to 526335. On far-end node PE-5, the global S-BFD configuration is as follows. This S-BFD discriminator will be advertised by IGP.

```

# on PE-5:
configure {
  bfd {
    seamless-bfd {
      reflector "PE-5" {
        admin-state enable
        discriminator 524291
      }
    }
  }
}

```

For S-BFD, a BFD template of type CPM-NP must be configured. On PE-2, the following BFD template is configured:

```
# on PE-2:
configure {
  bfd {
    bfd-template "bfd-cpm-np-1s" {
      receive-interval 1000 # minimum value is 10 ms
      transmit-interval 1000 # minimum value is 10 ms
      type cpm-np
    }
  }
}
```



**Note:**

Even though CPM-NP BFD can use intervals of minimum 10 ms, the used example setup has its limitations. The nodes in the used example setup are sims and the simulation for CPM-NP or central BFD sessions has the limitation that intervals that are configured with a value smaller than 1000 ms are always negotiated to intervals of 1000 ms. To avoid confusion when the configured intervals differ from the negotiated intervals on sims, a BFD template with intervals of 1000 ms is configured and used in this chapter.

On PE-2, the preceding BFD template is applied in the following SR-TE LSP to PE-5. For SR-TE LSPs, the only allowed failure action is **failover-or-down**.

```
# on PE-2:
configure {
  router "Base" {
    mpls {
      admin-state enable
      path "empty" {
        admin-state enable
      }
    }
    lsp "LSP-PE-2-PE-5_empty_localCSPF" {
      admin-state enable
      type p2p-sr-te
      to 192.0.2.5
      path-computation-method local-cspf
      bfd {
        bfd-liveness true
        bfd-template "bfd-cpm-np-1s"
        failure-action failover-or-down
      }
      primary "empty" {
      }
    }
  }
}
```

The following tunnel table on PE-2 shows that two tunnels are available toward PE-5: an SR-TE tunnel with tunnel ID 655362 and default preference 8, and an SR-ISIS tunnel with tunnel ID 524293 and default preference 11. The SR-TE tunnel with preference 8 is preferred to the SR-ISIS tunnel with preference 11.

```
[/]
A:admin@PE-2# show router tunnel-table 192.0.2.5/32

=====
IPv4 Tunnel Table (Router: Base)
=====
Destination      Owner      Encap TunnelId  Pref  Nexthop      Metric
  Color
-----
192.0.2.5/32     sr-te     MPLS  655362    8    192.168.24.2  20
```

```

192.0.2.5/32      isis (0) MPLS 524293 11 192.168.23.2 20
-----
Flags: B = BGP or MPLS backup hop available
      L = Loop-Free Alternate (LFA) hop available
      E = Inactive best-external BGP route
      k = RIB-API or Forwarding Policy backup hop
=====
  
```

The SR-TE LSP with tunnel ID 655362 is "LSP-PE-2-PE-5\_empty\_localCSPF":

```

[/]
A:admin@PE-2# show router mpls sr-te-lsp detail

=====
MPLS SR-TE LSPs (Originating) (Detail)
=====
Legend :
+ - Inherited
-----
Type : Originating
-----
LSP Name   : LSP-PE-2-PE-5_empty_localCSPF
LSP Type   : SrTeLsp                LSP Tunnel ID   : 1
LSP Index  : 65536                  TTM Tunnel Id   : 655362
From       : 192.0.2.2
To         : 192.0.2.5
Adm State  : Up                     Oper State       : Up
---snip---
  
```

The S-BFD session for the SR-TE LSP is up, as follows:

```

[/]
A:admin@PE-2# show router bfd seamless-bfd session
                    lsp-name "LSP-PE-2-PE-5_empty_localCSPF"

=====
Legend:
  Session Id = Interface Name | LSP Name | Prefix | RSVP Sess Name | Service Id
  wp = Working path  pp = Protecting path
=====
BFD Session
=====
Session Id          State      Tx Pkts  Rx Pkts
Rem Addr/Info/SdpId:VcId  Multipl  Tx Intvl  Rx Intvl
Protocols           Type      LAG Port  LAG ID
Loc Addr
-----
192.0.2.5/32        Up         N/A       N/A
192.0.2.5           3          1000     1000
mplsLsp             cpm-np     N/A       N/A
192.0.2.2
-----
No. of BFD sessions: 1
=====
  
```

## VPRN and EVPN services with auto-bind tunnel

Both VPRN "VPRN-1" and an EVPN VPLS "VPLS-2" will be configured on PE-2 and PE-5. For advertising VPN-IPv4 and EVPN routes, BGP is configured on PE-2 and PE-5 for the VPN-IPv4 and EVPN address families. Both VPRN "VPRN-1" and EVPN VPLS "VPLS-2" have auto-bind tunnel enabled with resolution filter allowing SR-ISIS and SR-TE.

```
# on PE-2:
configure {
  router "Base" {
    autonomous-system 64496
    bgp {
      vpn-apply-export true
      vpn-apply-import true
      rapid-withdrawal true
      split-horizon true
      rapid-update {
        vpn-ipv4 true
        evpn true
      }
      group "internal" {
        peer-as 64496
        family {
          vpn-ipv4 true
          evpn true
        }
      }
      neighbor "192.0.2.5" {
        group "internal"
      }
    }
  }
}
service {
  vpls "VPLS-2" {
    admin-state enable
    service-id 2
    customer "1"
    bgp 1 {
    }
    bgp-evpn {
      evi 2
      mpls 1 {
        admin-state enable
        auto-bind-tunnel {
          resolution filter
          resolution-filter {
            sr-isis true
            sr-te true
          }
        }
      }
    }
  }
  sap 1/1/c3/1:2 {
  }
}
vprn "VPRN-1" {
  admin-state enable
  service-id 1
  customer "1"
  bgp-ipvpn {
    mpls {

```

```

admin-state enable
route-distinguisher "64496:1"
vrf-target {
  community "target:64496:1"
}
auto-bind-tunnel {
  resolution filter
  resolution-filter {
    sr-isis true
    sr-te true
  }
}
}
}
interface "int-VPRN-1_PE-2_CE-11" {
  mac 00:00:5e:00:53:11
  ipv4 {
    primary {
      address 172.31.2.2
      prefix-length 30
    }
  }
  sap 1/1/c4/1:1 {
  }
}
}
}

```

The following route table for VPRN "VPRN-1" on PE-2 shows that the SR-TE tunnel with tunnel ID 655362 is used toward next-hop 192.0.2.5:

```

[/]
A:admin@PE-2# show router 1 route-table
=====
Route Table (Service: 1)
=====
Dest Prefix[Flags]                Type   Proto   Age           Pref
Next Hop[Interface Name]          Metric
-----
172.31.2.0/30                     Local  Local   00h01m53s    0
int-VPRN-1_PE-2_CE-11            0
172.31.5.4/30                     Remote BGP VPN 00h01m39s    170
192.0.2.5 (tunneled:SR-TE:655362) 20
-----
No. of Routes: 2
Flags: n = Number of times nexthop is repeated
       B = BGP backup route available
       L = LFA nexthop available
       S = Sticky ECMP requested
=====

```

Likewise, for the EVPN service, the SR-TE tunnel with tunnel ID 655362 is used toward 192.0.2.5, as follows:

```

[/]
A:admin@PE-2# show service id 2 fdb detail
=====
Forwarding Database, Service 2
=====
ServId   MAC                Source-Identifier   Type   Last Change
Transport:Tnl-Id
-----

```

```

-----
2          00:00:5e:00:53:12 sap:1/1/c3/1:2          L/0      07/05/23 15:17:23
2          00:00:5e:00:53:62 mpls-1:                Evpn     07/05/23 15:17:23
                        192.0.2.5:524285
          sr-te:655362
-----
No. of MAC Entries: 2
-----
Legend:  L=Learned O=Oam P=Protected-MAC C=Conditional S=Static Lf=Leaf
=====
  
```

```

[/]
A:admin@PE-2# show router bgp next-hop evpn service-id 2
=====
BGP Router ID:192.0.2.2      AS:64496      Local AS:64496
=====

BGP VPN Next Hop
=====
VPN Next Hop
Autobind                      FibProg      Owner
Labels (User-labels)         FlexAlgo     Reason
Admin-tag-policy (strict-tunnel-tagging)  Last Mod.

192.0.2.5
sr-isis sr-te                 Y            SR_TE
-- (3)                        --           20
-- (N)                        --           00h02m02s

Next Hops : 1
=====
  
```

### Failure of the SR-TE LSP

The following command shows that—without any failures—the primary path of the SR-TE LSP goes via PE-4:

```

[/]
A:admin@PE-2# show router mpls sr-te-lsp "LSP-PE-2-PE-5_empty_localCSPF" path detail
| match "Actual Hops" post-lines 3
Actual Hops      :
  192.168.24.2(192.0.2.4) (A-SID)      Record Label      : 524286
-> 192.168.45.2(192.0.2.5) (A-SID)      Record Label      : 524286
  
```

Figure 26: Primary path of SR-TE LSP via PE-4 shows the primary path of the SR-TE LSP.

Figure 26: Primary path of SR-TE LSP via PE-4

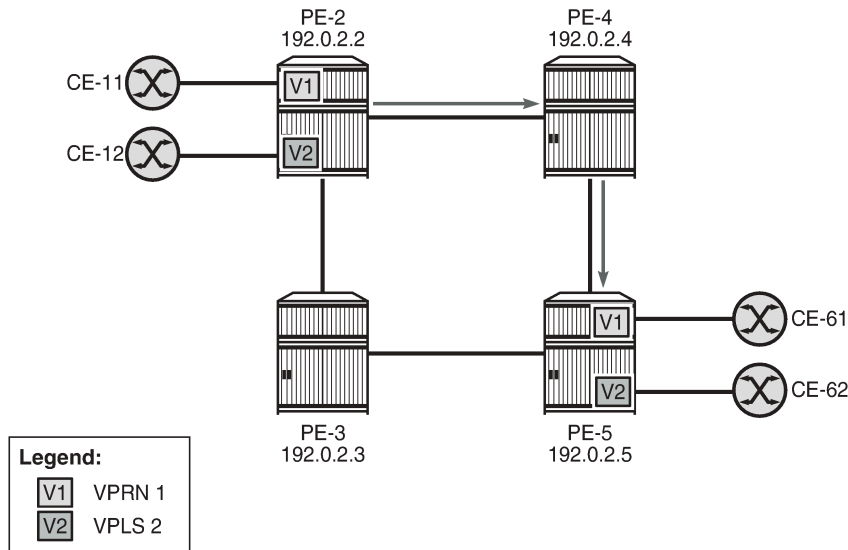

35837

S-BFD is configured in the SR-TE LSP with failure action **failover-or-down**. If the SR-TE LSP fails, the S-BFD session will go down and it will bring the SR-TE tunnel down. The next-hop 192.0.2.5 cannot be resolved using the SR-TE tunnel, so an SR-ISIS tunnel will be used instead.

On PE-4, port 1/1/c1/1 to PE-5 is disabled to emulate a failure in the primary path of the SR-TE LSP, as follows:

```
# on PE-4:
configure {
  port 1/1/c1/1 {      # port to PE-5
    admin-state disable
```

Figure 27: Remote failure in the primary path of the SR-TE LSP shows that a remote failure occurs in the primary path of the SR-TE LSP.

Figure 27: Remote failure in the primary path of the SR-TE LSP

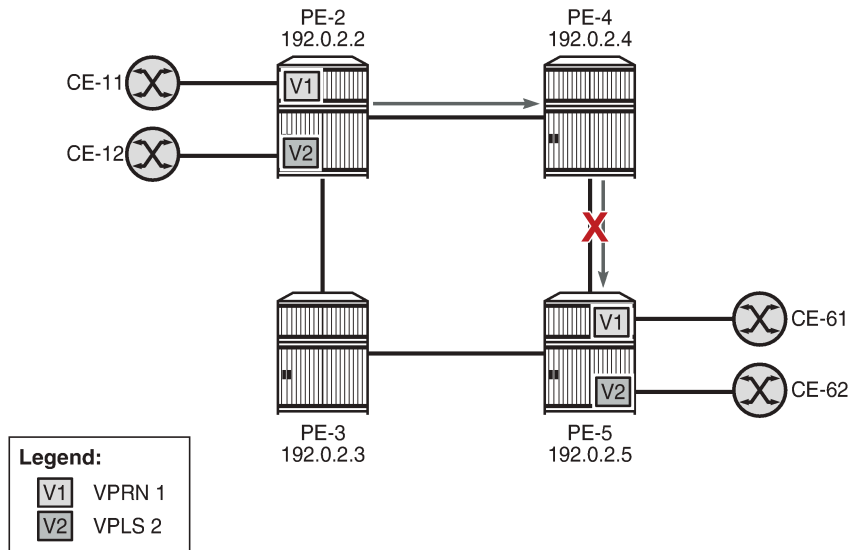

35838

The S-BFD session goes operationally down, as follows:

```
[/]
A:admin@PE-2# show router bfd seamless-bfd session lsp-path detail prefix 192.0.2.5/32

=====
BFD Session
=====
Prefix       : 192.0.2.5/32
Local Address : 192.0.2.2
LSP Name     : LSP-PE-2-PE-5_empty_localCSPF
LSP Index    : 65536
Fec Type     : srTe
Path LSP ID  : 4096
Oper State   : Down
Last Up Time : 0d 00:04:14
Down Time    : 0d 00:00:01
Protocols    : mplsLsp
Up Transitions : 1
Down Transitions : 1
Version Mismatch : 0

Forwarding Information

Local Discr   : 1
Local Diag    : 1 (Detect time expired)
Local Mode    : Demand
Local Min Tx  : 1000
Last Sent (ms) : 0
Type         : cpm-np
Remote       : Unheard
Local State   : Down
Local Mult    : 3
Local Min Rx  : 0
Remote Discr  : 524291
=====
```

When the S-BFD session goes down, the SR-TE LSP goes operationally down, as follows:

```
[/]
A:admin@PE-2# show router mpls sr-te-lsp

=====
```



```
MPLS SR-TE LSPs (Originating)
=====
LSP Name          Tun   Protect  Adm  Opr
  To              Id     Path
-----
LSP-PE-2-PE-5_empty_localCSPF
  192.0.2.5       1     N/A     Up   Dwn
-----
LSPs : 1
=====
```

Because the SR-TE tunnel is operationally down, the only available tunnel to 192.0.2.5 is the SR-ISIS tunnel, as follows:

```
[/]
A:admin@PE-2# show router tunnel-table 192.0.2.5/32
=====
IPv4 Tunnel Table (Router: Base)
=====
Destination      Owner      Encap TunnelId Pref  Nexthop      Metric
  Color
-----
192.0.2.5/32     isis (0)  MPLS  524293   11   192.168.23.2  20
-----
Flags: B = BGP or MPLS backup hop available
       L = Loop-Free Alternate (LFA) hop available
       E = Inactive best-external BGP route
       k = RIB-API or Forwarding Policy backup hop
=====
```

The route table for VPRN "VPRN-1" shows that an SR-ISIS tunnel is used toward next-hop 192.0.2.5:

```
[/]
A:admin@PE-2# show router 1 route-table
=====
Route Table (Service: 1)
=====
Dest Prefix[Flags]      Type  Proto  Age      Pref
  Next Hop[Interface Name]  Metric
-----
172.31.2.0/30           Local  Local  00h03m17s  0
  int-VPRN-1_PE-2_CE-11  0
172.31.5.4/30           Remote BGP VPN 00h00m12s 170
  192.0.2.5 (tunneled:SR-ISIS:524293) 20
-----
No. of Routes: 2
Flags: n = Number of times nexthop is repeated
       B = BGP backup route available
       L = LFA nexthop available
       S = Sticky ECMP requested
=====
```

Likewise, the FDB for the EVPN VPLS "VPLS-2" shows that an SR-ISIS tunnel with tunnel ID 524293 is used toward next-hop 192.0.2.5:

```
[/]
A:admin@PE-2# show service id 2 fdb detail
=====
```

```
Forwarding Database, Service 2
=====
ServId   MAC                               Source-Identifier   Type   Last Change
         Transport:Tnl-Id
-----
2        00:00:5e:00:53:12  sap:1/1/c3/1:2     L/60   07/05/23 15:17:23
2        00:00:5e:00:53:62  mpls-1:           Evpn   07/05/23 15:17:23
         192.0.2.5:524285
         isis:524293
-----
No. of MAC Entries: 2
-----
Legend:  L=Learned O=Oam P=Protected-MAC C=Conditional S=Static Lf=Leaf
=====
```

### SR-TE LSP reconnects after retry timer expires

When the SR-TE LSP retry timer expires, the primary path is recalculated and it will go via PE-3 (192.0.2.3), as follows:

```
[/]
A:admin@PE-2# show router mpls sr-te-lsp "LSP-PE-2-PE-5_empty_localCSPF" path detail
| match "Actual Hops" post-lines 3
Actual Hops      :
  192.168.23.2(192.0.2.3) (A-SID)      Record Label      : 524287
-> 192.168.35.2(192.0.2.5) (A-SID)      Record Label      : 524286
```

Figure 28: SR-TE LSP reconnects after retry timer expires show that the primary path of the SR-TE tunnel goes via PE-3.

Figure 28: SR-TE LSP reconnects after retry timer expires

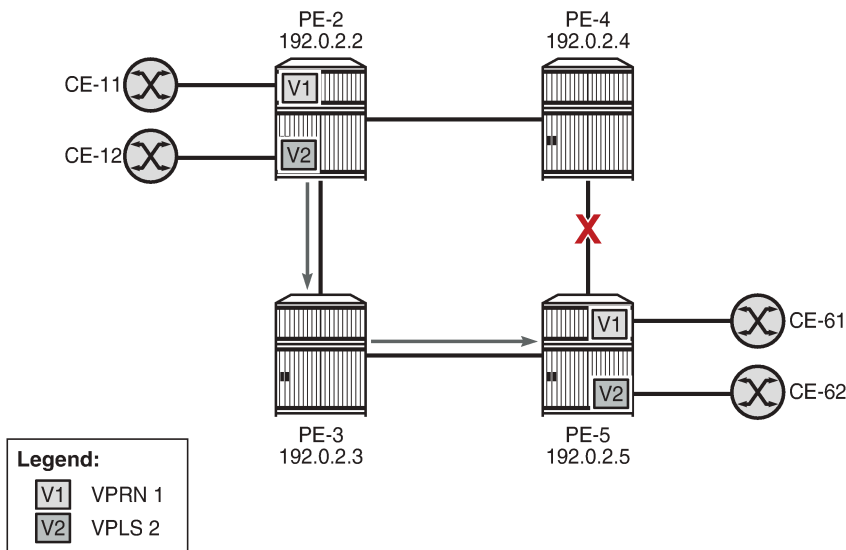

35839

The tunnel table shows two tunnels to 192.0.2.5: one SR-TE tunnel with tunnel ID 655362 and one SR-ISIS tunnel with tunnel ID 524293:

```
[/]
A:admin@PE-2# show router tunnel-table 192.0.2.5/32

=====
IPv4 Tunnel Table (Router: Base)
=====
Destination          Owner      Encap TunnelId  Pref  Nexthop      Metric
  Color
-----
192.0.2.5/32         sr-te     MPLS 655362    8    192.168.23.2  20
192.0.2.5/32         isis (0)  MPLS 524293   11    192.168.23.2  20
-----
Flags: B = BGP or MPLS backup hop available
       L = Loop-Free Alternate (LFA) hop available
       E = Inactive best-external BGP route
       k = RIB-API or Forwarding Policy backup hop
=====
```

Again, the SR-TE LSP will be preferred to the SR-ISIS LSP and both VPRN "VPRN-1" and EVPN VPLS "VPLS-2" will use the SR-TE tunnel to 192.0.2.5.

## Conclusion

S-BFD can be used to determine the state of SR-TE LSPs that only have a primary path. The resiliency is at the service level for VPRN and EVPN services with auto-bind tunnel where several resolution protocols are configured and SR-TE has the lowest preference. When the S-BFD session for the SR-TE tunnel goes operationally down, the SR-TE tunnel goes operationally down. The VPRN and EVPN services will then use the best tunnel that is available; in this example, an SR-ISIS tunnel.

# Customer document and product support

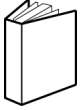

## **Customer documentation**

[Customer documentation welcome page](#)



## **Technical support**

[Product support portal](#)



## **Documentation feedback**

[Customer documentation feedback](#)