



Alcatel-Lucent 5620

SERVICE AWARE MANAGER | RELEASE 10.0 R7
OPTICAL USER GUIDE

3HE 06986 AAAG TQZZA Edition 01

Alcatel-Lucent Proprietary
This document contains proprietary information of Alcatel-Lucent and is not to be disclosed
or used except in accordance with applicable agreements.
Copyright 2012-2013 © Alcatel-Lucent. All rights reserved.

Alcatel-Lucent assumes no responsibility for the accuracy of the information presented, which is subject to change without notice.

Alcatel, Lucent, Alcatel-Lucent, the Alcatel-Lucent logo, lightRadio, and TiMetra are registered trademarks of Alcatel-Lucent. All other trademarks are the property of their respective owners.

Copyright 2012-2013 Alcatel-Lucent.
All rights reserved.

Disclaimers

Alcatel-Lucent products are intended for commercial uses. Without the appropriate network design engineering, they must not be sold, licensed or otherwise distributed for use in any hazardous environments requiring fail-safe performance, such as in the operation of nuclear facilities, aircraft navigation or communication systems, air traffic control, direct life-support machines, or weapons systems, in which the failure of products could lead directly to death, personal injury, or severe physical or environmental damage. The customer hereby agrees that the use, sale, license or other distribution of the products for any such application without the prior written consent of Alcatel-Lucent, shall be at the customer's sole risk. The customer hereby agrees to defend and hold Alcatel-Lucent harmless from any claims for loss, cost, damage, expense or liability that may arise out of or in connection with the use, sale, license or other distribution of the products in such applications.

This document may contain information regarding the use and installation of non-Alcatel-Lucent products. Please note that this information is provided as a courtesy to assist you. While Alcatel-Lucent tries to ensure that this information accurately reflects information provided by the supplier, please refer to the materials provided with any non-Alcatel-Lucent product and contact the supplier for confirmation. Alcatel-Lucent assumes no responsibility or liability for incorrect or incomplete information provided about non-Alcatel-Lucent products.

However, this does not constitute a representation or warranty. The warranties provided for Alcatel-Lucent products, if any, are set forth in contractual documentation entered into by Alcatel-Lucent and its customers.

This document was originally written in English. If there is any conflict or inconsistency between the English version and any other version of a document, the English version shall prevail.

Alcatel-Lucent License Agreement

SAMPLE END USER LICENSE AGREEMENT

1. LICENSE

- 1.1 Subject to the terms and conditions of this Agreement, Alcatel-Lucent grants to Customer and Customer accepts a nonexclusive, nontransferable license to use any software and related documentation provided by Alcatel-Lucent pursuant to this Agreement ("Licensed Program") for Customer's own internal use, solely in conjunction with hardware supplied or approved by Alcatel-Lucent. In case of equipment failure, Customer may use the Licensed Program on a backup system, but only for such limited time as is required to rectify the failure.
- 1.2 Customer acknowledges that Alcatel-Lucent may have encoded within the Licensed Program optional functionality and capacity (including, but not limited to, the number of equivalent nodes, delegate workstations, paths and partitions), which may be increased upon the purchase of the applicable license extensions.
- 1.3 Use of the Licensed Program may be subject to the issuance of an application key, which shall be conveyed to the Customer in the form of a Supplement to this End User License Agreement. The purchase of a license extension may require the issuance of a new application key.

2. PROTECTION AND SECURITY OF LICENSED PROGRAMS

- 2.1 Customer acknowledges and agrees that the Licensed Program contains proprietary and confidential information of Alcatel-Lucent and its third party suppliers, and agrees to keep such information confidential. Customer shall not disclose the Licensed Program except to its employees having a need to know, and only after they have been advised of its confidential and proprietary nature and have agreed to protect same.
- 2.2 All rights, title and interest in and to the Licensed Program, other than those expressly granted to Customer herein, shall remain vested in Alcatel-Lucent or its third party suppliers. Customer shall not, and shall prevent others from copying, translating, modifying, creating derivative works, reverse engineering, decompiling, encumbering or otherwise using the Licensed Program except as specifically authorized under this Agreement. Notwithstanding the foregoing, Customer is authorized to make one copy for its archival purposes only. All appropriate copyright and other proprietary notices and legends shall be placed on all Licensed Programs supplied by Alcatel-Lucent, and Customer shall maintain and reproduce such notices on any full or partial copies made by it.

3. TERM

- 3.1 This Agreement shall become effective for each Licensed Program upon delivery of the Licensed Program to Customer.

-
- 3.2 Alcatel-Lucent may terminate this Agreement: (a) upon notice to Customer if any amount payable to Alcatel-Lucent is not paid within thirty (30) days of the date on which payment is due; (b) if Customer becomes bankrupt, makes an assignment for the benefit of its creditors, or if its assets vest or become subject to the rights of any trustee, receiver or other administrator; (c) if bankruptcy, reorganization or insolvency proceedings are instituted against Customer and not dismissed within 15 days; or (d) if Customer breaches a material provision of this Agreement and such breach is not rectified within 15 days of receipt of notice of the breach from Alcatel-Lucent.
- 3.3 Upon termination of this Agreement, Customer shall return or destroy all copies of the Licensed Program. All obligations of Customer arising prior to termination, and those obligations relating to confidentiality and nonuse, shall survive termination.

4. CHARGES

- 4.1 Upon shipment of the Licensed Program, Alcatel-Lucent will invoice Customer for all fees, and any taxes, duties and other charges. Customer will be invoiced for any license extensions upon delivery of the new software application key or, if a new application key is not required, upon delivery of the extension. All amounts shall be due and payable within thirty (30) days of receipt of invoice, and interest will be charged on any overdue amounts at the rate of 1 1/2% per month (19.6% per annum).

5. SUPPORT AND UPGRADES

- 5.1 Customer shall receive software support and upgrades for the Licensed Program only to the extent provided for in the applicable Alcatel-Lucent software support policy in effect from time to time, and upon payment of any applicable fees. Unless expressly excluded, this Agreement shall be deemed to apply to all updates, upgrades, revisions, enhancements and other software which may be supplied by Alcatel-Lucent to Customer from time to time.

6. WARRANTIES AND INDEMNIFICATION

- 6.1 Alcatel-Lucent warrants that the Licensed Program as originally delivered to Customer will function substantially in accordance with the functional description set out in the associated user documentation for a period of 90 days from the date of shipment, when used in accordance with the user documentation. Alcatel-Lucent's sole liability and Customer's sole remedy for a breach of this warranty shall be Alcatel-Lucent's good faith efforts to rectify the nonconformity or, if after repeated efforts Alcatel-Lucent is unable to rectify the nonconformity, Alcatel-Lucent shall accept return of the Licensed Program and shall refund to Customer all amounts paid in respect thereof. This warranty is available only once in respect of each Licensed Program, and is not renewed by the payment of an extension charge or upgrade fee.

-
- 6.2 ALCATEL-LUCENT EXPRESSLY DISCLAIMS ALL OTHER WARRANTIES, REPRESENTATIONS, COVENANTS OR CONDITIONS OF ANY KIND, WHETHER EXPRESS OR IMPLIED, INCLUDING WITHOUT LIMITATION, WARRANTIES OR REPRESENTATIONS OF WORKMANSHIP, MERCHANTABILITY, FITNESS FOR A PARTICULAR PURPOSE, DURABILITY, OR THAT THE OPERATION OF THE LICENSED PROGRAM WILL BE ERROR FREE OR THAT THE LICENSED PROGRAMS WILL NOT INFRINGE UPON ANY THIRD PARTY RIGHTS.
- 6.3 Alcatel-Lucent shall defend and indemnify Customer in any action to the extent that it is based on a claim that the Licensed Program furnished by Alcatel-Lucent infringes any patent, copyright, trade secret or other intellectual property right, provided that Customer notifies Alcatel-Lucent within ten (10) days of the existence of the claim, gives Alcatel-Lucent sole control of the litigation or settlement of the claim, and provides all such assistance as Alcatel-Lucent may reasonably require. Notwithstanding the foregoing, Alcatel-Lucent shall have no liability if the claim results from any modification or unauthorized use of the Licensed Program by Customer, and Customer shall defend and indemnify Alcatel-Lucent against any such claim.
- 6.4 Alcatel-Lucent Products are intended for standard commercial uses. Without the appropriate network design engineering, they must not be sold, licensed or otherwise distributed for use in any hazardous environments requiring fail safe performance, such as in the operation of nuclear facilities, aircraft navigation or communication systems, air traffic control, direct life-support machines, or weapons systems, in which the failure of products could lead directly to death, personal injury, or severe physical or environmental damage. The Customer hereby agrees that the use, sale, license or other distribution of the Products for any such application without the prior written consent of Alcatel-Lucent, shall be at the Customer's sole risk. The Customer also agrees to defend and hold Alcatel-Lucent harmless from any claims for loss, cost, damage, expense or liability that may arise out of or in connection with the use, sale, license or other distribution of the Products in such applications.

7. LIMITATION OF LIABILITY

- 7.1 IN NO EVENT SHALL THE TOTAL COLLECTIVE LIABILITY OF ALCATEL-LUCENT, ITS EMPLOYEES, DIRECTORS, OFFICERS OR AGENTS FOR ANY CLAIM, REGARDLESS OF VALUE OR NATURE, EXCEED THE AMOUNT PAID UNDER THIS AGREEMENT FOR THE LICENSED PROGRAM THAT IS THE SUBJECT MATTER OF THE CLAIM. IN NO EVENT SHALL THE TOTAL COLLECTIVE LIABILITY OF ALCATEL-LUCENT, ITS EMPLOYEES, DIRECTORS, OFFICERS OR AGENTS FOR ALL CLAIMS EXCEED THE TOTAL AMOUNT PAID BY CUSTOMER TO ALCATEL-LUCENT HEREUNDER. NO PARTY SHALL BE LIABLE FOR ANY INDIRECT, SPECIAL OR CONSEQUENTIAL DAMAGES, WHETHER OR NOT SUCH DAMAGES ARE FORESEEABLE, AND/OR THE PARTY HAD BEEN ADVISED OF THE POSSIBILITY OF SUCH DAMAGES.
- 7.2 The foregoing provision limiting the liability of Alcatel-Lucent's employees, agents, officers and directors shall be deemed to be a trust provision, and shall be enforceable by such employees, agents, officers and directors as trust beneficiaries.

8. GENERAL

- 8.1 Under no circumstances shall either party be liable to the other for any failure to perform its obligations (other than the payment of any monies owing) where such failure results from causes beyond that party's reasonable control.
- 8.2 This Agreement constitutes the entire agreement between Alcatel-Lucent and Customer and supersedes all prior oral and written communications. All amendments shall be in writing and signed by authorized representatives of both parties.
- 8.3 If any provision of this Agreement is held to be invalid, illegal or unenforceable, it shall be severed and the remaining provisions shall continue in full force and effect.
- 8.4 The Licensed Program may contain freeware or shareware obtained by Alcatel-Lucent from a third party source. No license fee has been paid by Alcatel-Lucent for the inclusion of any such freeware or shareware, and no license fee is charged to Customer for its use. The Customer agrees to be bound by any license agreement for such freeware or shareware. CUSTOMER ACKNOWLEDGES AND AGREES THAT THE THIRD PARTY SOURCE PROVIDES NO WARRANTIES AND SHALL HAVE NO LIABILITY WHATSOEVER IN RESPECT OF CUSTOMER'S POSSESSION AND/OR USE OF THE FREWARE OR SHAREWARE.
- 8.5 Alcatel-Lucent shall have the right, at its own expense and upon reasonable written notice to Customer, to periodically inspect Customer's premises and such documents as it may reasonably require, for the exclusive purpose of verifying Customer's compliance with its obligations under this Agreement.
- 8.6 All notices shall be sent to the parties at the addresses listed above, or to any such address as may be specified from time to time. Notices shall be deemed to have been received five days after deposit with a post office when sent by registered or certified mail, postage prepaid and receipt requested.
- 8.7 If the Licensed Program is being acquired by or on behalf of any unit or agency of the United States Government, the following provision shall apply: If the Licensed Program is supplied to the Department of Defense, it shall be classified as "Commercial Computer Software" and the United States Government is acquiring only "restricted rights" in the Licensed Program as defined in DFARS 227-7202-1(a) and 227.7202-3(a), or equivalent. If the Licensed Program is supplied to any other unit or agency of the United States Government, rights will be defined in Clause 52.227-19 or 52.227-14 of the FAR, or if acquired by NASA, Clause 18-52.227-86(d) of the NASA Supplement to the FAR, or equivalent. If the software was acquired under a contract subject to the October 1988 Rights in Technical Data and Computer Software regulations, use, duplication and disclosure by the Government is subject to the restrictions set forth in DFARS 252-227.7013(c)(1)(ii) 1988, or equivalent.
- 8.8 Customer shall comply with all export regulations pertaining to the Licensed Program in effect from time to time. Without limiting the generality of the foregoing, Customer expressly warrants that it will not directly or indirectly export, reexport, or transship the Licensed Program in violation of any export laws, rules or regulations of Canada, the United States or the United Kingdom.

-
- 8.9 No term or provision of this Agreement shall be deemed waived and no breach excused unless such waiver or consent is in writing and signed by the party claimed to have waived or consented. The waiver by either party of any right hereunder, or of the failure to perform or of a breach by the other party, shall not be deemed to be a waiver of any other right hereunder or of any other breach or failure by such other party, whether of a similar nature or otherwise.
- 8.10 This Agreement shall be governed by and construed in accordance with the laws of the Province of Ontario. The application of the United Nations Convention on Contracts for the International Sale of Goods is hereby expressly excluded.

Preface

The Preface provides general information about the 5620 Service Aware Manager documentation suite, including this guide.

Prerequisites

Readers of the 5620 SAM documentation suite are assumed to be familiar with the following:

- 5620 SAM software structure and components
- 5620 SAM GUI operations and tools
- typical 5620 SAM management tasks and procedures
- device and network management concepts

5620 SAM documentation suite

The 5620 SAM documentation suite describes the 5620 SAM and the associated network management of its supported devices. Contact your Alcatel-Lucent support representative for information about specific network or facility considerations.

Table 1 lists the documents in the 5620 SAM customer documentation suite.

Table 1 5620 SAM customer documentation suite

Guide	Description
5620 SAM core documentation	
<i>5620 SAM Release Description</i>	The <i>5620 SAM Release Description</i> provides information about the new features associated with a 5620 SAM software release.

(1 of 4)

Guide	Description
<i>5620 SAM Planning Guide</i>	The <i>5620 SAM Planning Guide</i> provides information about 5620 SAM scalability and recommended hardware configurations.
<i>5620 SAM System Architecture Guide</i>	The <i>5620 SAM System Architecture Guide</i> is intended for technology officers and network planners to increase their knowledge of the 5620 SAM software structure and components. It describes the system structure, software components, and interfaces of the 5620 SAM. In addition, 5620 SAM fault tolerance, security, and network management capabilities are discussed from an architectural perspective.
<i>5620 SAM 5650 CPAM Installation and Upgrade Guide</i>	The <i>5620 SAM 5650 CPAM Installation and Upgrade Guide</i> provides OS considerations, configuration information, and procedures for the following: <ul style="list-style-type: none"> installing, upgrading, and uninstalling 5620 SAM and 5650 CPAM software in standalone and redundant deployments 5620 SAM system migration to a different system conversion from a standalone to a redundant 5620 SAM system
<i>5620 SAM User Guide</i>	The <i>5620 SAM User Guide</i> provides information about using the 5620 SAM to manage the service-aware IP/MPLS network, including GUI basics, commissioning, service configuration, and policy management. The <i>5620 SAM User Guide</i> uses a task-based format. Each chapter contains: <ul style="list-style-type: none"> a workflow that describes the steps for configuring and using the functions detailed procedures that list the configurable parameters on the associated forms 5620 SAM management information specific to LTE network elements is covered in the <i>5620 SAM LTE ePC User Guide</i> and <i>5620 SAM LTE RAN User Guide</i> . 5620 SAM management information specific to 1830 PSS network elements is covered in the <i>5620 SAM Optical User Guide</i> .
<i>5620 SAM Integration Guide</i>	The <i>5620 SAM Integration Guide</i> provides procedures to allow the 5620 SAM to integrate with additional components.
<i>5620 SAM Supervision Module User Guide</i>	The <i>5620 SAM Supervision Module User Guide</i> provides information about how to configure and use the web-based 5620 SAM Supervision Module for fault management and at-a-glance network element monitoring.
<i>5620 SAM Scripts and Templates Developer Guide</i>	The <i>5620 SAM Scripts and Templates Developer Guide</i> provides information that allows users to develop, manage, and execute CLI-based or XML-based scripts or templates. The guide is intended for developers, skilled administrators, and operators who are expected to be familiar with the following: <ul style="list-style-type: none"> CLI scripting, XML, and the Velocity engine basic scripting or programming 5620 SAM functions
<i>5620 SAM Parameter Guide</i>	The <i>5620 SAM Parameter Guide</i> provides: <ul style="list-style-type: none"> parameter descriptions that include value ranges and default values parameter options and option descriptions parameter and option dependencies parameter mappings to the 5620 SAM-O XML equivalent property names There are dynamic links between the procedures in the <i>5620 SAM User Guide</i> and the parameter descriptions in the <i>5620 SAM Parameter Guide</i> . Parameters specific to LTE network elements are covered in the <i>5620 SAM LTE Parameter Reference</i> . Parameters specific to 1830 PSS network elements are covered in the <i>5620 SAM Optical Parameter Reference</i> .
<i>5620 SAM Statistics Management Guide</i>	The <i>5620 SAM Statistics Management Guide</i> provides information about how to configure performance and accounting statistics collection and how to view counters using the 5620 SAM. Network examples are included.

(2 of 4)

Guide	Description
<i>5620 SAM Maintenance Guide</i>	The <i>5620 SAM Maintenance Guide</i> provides procedures for: <ul style="list-style-type: none"> generating baseline information for 5620 SAM applications performing daily, weekly, monthly, and as-required maintenance activities for 5620 SAM-managed networks
<i>5620 SAM Troubleshooting Guide</i>	The <i>5620 SAM Troubleshooting Guide</i> provides task-based procedures and user documentation to: <ul style="list-style-type: none"> help resolve issues in the managed and management networks identify the root cause and plan corrective action for: <ul style="list-style-type: none"> alarm conditions on a network object or customer service problems on customer services with no associated alarms list problem scenarios, possible solutions, and tools to help check: <ul style="list-style-type: none"> network management LANs network management platforms and operating systems 5620 SAM client GUIs and client OSS applications 5620 SAM servers 5620 SAM databases
<i>5620 SAM Alarm Reference</i>	The <i>5620 SAM Alarm Reference</i> provides a description of all alarms supported on the 5620 SAM, including LTE and optical alarms, the raising and clearing conditions of each alarm, and the remedial action to fix the problem. The reference is organized by network element type.
<i>5620 SAM Glossary</i>	The <i>5620 SAM Glossary</i> defines terms and acronyms used in all of the 5620 SAM documentation, including 5620 SAM LTE documentation.
<i>5620 SAM Network Element Compatibility Guide</i>	The <i>5620 SAM Network Element Compatibility Guide</i> provides release-specific information about the compatibility of managed devices in 5620 SAM releases. This document is updated regularly; always consult the latest version on QLCS as described in Documentation and resources on the web .
5620 SAM LTE documentation	
<i>5620 SAM LTE Release Description</i>	The <i>5620 SAM LTE Release Description</i> provides information about the LTE features associated with the release.
<i>5620 SAM LTE ePC User Guide</i>	The <i>5620 SAM LTE ePC User Guide</i> describes how to discover, configure, and manage LTE ePC devices using the 5620 SAM. The guide is intended for LTE ePC network planners, administrators, and operators and is to be used in conjunction with other guides in the 5620 SAM documentation suite where management of ePC devices does not differ from other network elements. Alcatel-Lucent recommends that you review the entire <i>5620 SAM LTE ePC User Guide</i> before you attempt to use the 5620 SAM in your LTE network.
<i>5620 SAM LTE RAN User Guide</i>	The <i>5620 SAM LTE RAN User Guide</i> describes how to discover, configure, and manage the Evolved NodeB, or eNodeB, using the 5620 SAM. The guide is intended for LTE RAN network planners, administrators, and operators and is to be used in conjunction with other guides in the 5620 SAM documentation suite where management of RAN devices does not differ from other network elements. Alcatel-Lucent recommends that you review the entire <i>5620 SAM LTE RAN User Guide</i> before you attempt to use the 5620 SAM in your LTE network.
<i>5620 SAM LTE Parameter Reference</i>	The <i>5620 SAM LTE Parameter Reference</i> provides a list of all LTE ePC and LTE RAN parameters supported in the 5620 SAM.
5620 SAM-O documentation	
<i>5620 SAM XML OSS Interface Developer Guide</i>	The <i>5620 SAM XML OSS Interface Developer Guide</i> provides information that allows you to: <ul style="list-style-type: none"> use the 5620 SAM XML OSS interface to access network management information learn about the information model associated with the managed network develop OSS applications using the packaged methods, classes, data types, and objects necessary to manage 5620 SAM functions

(3 of 4)

Guide	Description
<i>5620 SAM 3GPP OSS Interface Developer Guide</i>	The <i>5620 SAM 3GPP OSS Interface Developer Guide</i> describes the components and architecture of the 3GPP OSS interface to the 5620 SAM. It includes procedures and samples to assist OSS application developers to use the 3GPP interface to manage LTE devices.
<i>5620 SAM 3GPP OSS Interface Compliance Statements</i>	The <i>5620 SAM 3GPP OSS Interface Compliance Statements</i> document describes the compliance of the 5620 SAM 3GPP OSS interface with the 3GPP standard.
5620 SAM optical documentation	
<i>5620 SAM Optical User Guide</i>	The <i>5620 SAM Optical User Guide</i> describes how to discover, configure, and manage optical devices using the 5620 SAM. The guide is intended for optical network planners, administrators, and operators and is to be used in conjunction with other guides in the 5620 SAM documentation suite where management of optical devices does not differ from other network elements. Alcatel-Lucent recommends that you review the entire <i>5620 SAM Optical User Guide</i> before you attempt to use the 5620 SAM in your network.
<i>5620 SAM Optical Parameter Reference</i>	The <i>5620 SAM Optical Parameter Reference</i> provides a list of all optical device parameters supported in the 5620 SAM.
5650 CPAM documentation	
<i>5650 CPAM User Guide</i>	The <i>5650 CPAM User Guide</i> describes how to capture, inspect, visualize, and troubleshoot IGP and BGP topologies using the 5650 CPAM.
<i>7701 CPAA Hardware Revision 1 Setup and Software Installation Instructions</i>	The <i>7701 CPAA Hardware Revision 2 Setup and Software Installation Instructions</i> describes the hardware setup and software installation for the 7701 CPAA Hardware Revision 1, the route analyzer component of the 5650 CPAM.
<i>7701 CPAA Hardware Revision 2 Setup and Software Installation Instructions</i>	The <i>7701 CPAA Hardware Revision 2 Setup and Software Installation Instructions</i> describes the hardware setup and software installation for the 7701 CPAA Hardware Revision 2, the route analyzer component of the 5650 CPAM.

(4 of 4)

Obtaining customer documentation

You can obtain 5620 SAM customer documentation:

- from the product
- on the web

On-product documentation

The 5620 SAM on-product customer documentation is delivered in HTML and PDF. Choose Help→User Documentation from the 5620 SAM client GUI to open the help system in a web browser.

The help system opens to the User Documentation Index, which provides a summary of and links to all 5620 SAM customer documents.

Click on the Using the help system tab on the User Documentation Index page to find usage tips for navigating and searching within the on-product customer documentation.

You can return to the User Documentation Index at any time by clicking on the Home icon, shown in Figure 1.

Figure 1 Home icon



Documentation and resources on the web

The 5620 SAM customer documentation is available for download in PDF format from the Alcatel-Lucent Customer Support Center: <http://www.alcatel-lucent.com/myaccess>. If you are a new user and require access to this service, please contact your Alcatel-Lucent support representative.

In addition to the guides listed in Table 1, Release Notices and other documents not delivered on-product are posted to this site.

5620 SAM product alerts

Product technical alerts are used to communicate important information to customers about released loads. You can view and subscribe to [product alerts for the 5620 SAM](#) from the Alcatel-Lucent Customer Support Center.

Working with PDFs

You can download PDFs of individual guides from the Alcatel-Lucent Customer Support Center, or you can choose to download a zip of all PDFs for a particular release.

You can use the Search function of Acrobat Reader (File→Search) to find a term in a PDF of any 5620 SAM document. To refine your search, use appropriate search options (for example, search for whole words only or enable case-sensitive searching). You can also search for a term in multiple PDFs at once, provided that they are located in the same directory. For more information, see the Help for Acrobat Reader.

Cross-book hotlinks, for example, from a parameter name in the *5620 SAM User Guide* to a description of that parameter in the *5620 SAM Parameter Guide*, work only if both PDF files are in the same directory.



Note — Users of Mozilla browsers may receive an error message when opening the PDF files in the 5620 SAM documentation suite. The offline storage and default cache values used by the browsers are the cause of the error message.

Alcatel-Lucent recommends changing the Mozilla Firefox offline storage or Mozilla 1.7 cache value to 100 Mbytes to eliminate the error message.

Documentation conventions

Table 2 lists the conventions that are used throughout the documentation.

Table 2 Documentation conventions

Convention	Description	Example
Key name	Press a keyboard key	Delete
Italics	Identifies a variable	<i>hostname</i>
Key+Key	Type the appropriate consecutive keystroke sequence	CTRL+G
Key–Key	Type the appropriate simultaneous keystroke sequence	CTRL–G
*	An asterisk is a wildcard character, which means “any character” in a search argument.	log_file*.txt
↵	Press the Return key	↵
—	An em dash indicates there is no information.	—
→	Indicates that a cascading submenu results from selecting a menu item	Policies→Alarm Policies

Procedures with options or substeps

When there are options in a procedure, they are identified by letters. When there are substeps in a procedure, they are identified by Roman numerals.

Example of options in a procedure

At step 1, you can choose option a or b. At step 2, you must do what the step indicates.

- 1 This step offers two options. You must choose one of the following.
 - a This is one option.
 - b This is another option.
- 2 You must perform this step.

Example of substeps in a procedure

At step 1, you must perform a series of substeps within a step. At step 2, you must do what the step indicates.

- 1 This step has a series of substeps that you must perform to complete the step. You must perform the following substeps.
 - i This is the first substep.
 - ii This is the second substep.
 - iii This is the third substep.
- 2 You must perform this step.

Measurement conventions

Measurements in this document are expressed in metric units and follow the *Système international d'unités* (SI) standard for abbreviation of metric units. If imperial measurements are included, they appear in brackets following the metric unit.

Table 3 lists the measurement symbols used in this document.

Table 3 Bits and bytes conventions

Measurement	Symbol
bit	b
byte	byte
kilobits per second	kb/s

Important information

The following conventions are used to indicate important information:



Warning — Warning indicates that the described activity or situation may, or will, cause equipment damage or serious performance problems.



Caution — Caution indicates that the described activity or situation may, or will, cause service interruption.



Note — Notes provide information that is, or may be, of special interest.

Contents

Preface	ix
Prerequisites.....	ix
5620 SAM documentation suite	ix
Obtaining customer documentation	xii
On-product documentation	xii
Documentation and resources on the web	xiii
Documentation conventions.....	xiii
Procedures with options or substeps.....	xiv
Measurement conventions	xv
Important information.....	xv

Getting started

1 — 1830 PSS overview	1-1
1.1 Overview of the 1830 PSS.....	1-2
1830 PSS-32 central office device/1830 PSS-16 end office device	1-2
1830 PSS-4 edge device platform	1-3
1830 PSS-1 GBE edge device.....	1-3
1830 PSS-1 MD4H edge device.....	1-4
1830 PSS-1 AHP amplifier	1-4
1.2 Component configuration	1-5
1.3 About this guide	1-5
1.4 1830 PSS reference documentation	1-6

2 —	5620 SAM optical features	2-1
2.1	1830 PSS features for 5620 SAM Release 10.0	2-2
3 —	1830 PSS map management	3-1
3.1	5620 SAM network topology maps	3-2
	Service topology map.....	3-2
	Physical topology map.....	3-2
3.2	Procedures to view optical and IP interconnections.....	3-2
	Procedure 3-1 To view optical interconnections only	3-2
	Procedure 3-2 To view IP interconnections only	3-3
4 —	1830 PSS user security	4-1
4.1	User security overview	4-2
4.2	5620 SAM user and user group security	4-2
	Span of control	4-2

1830 PSS device management using the 5620 SAM

5 —	1830 PSS device management	5-1
5.1	Device management overview	5-2
	Procedure 5-1 To view an invalid or stale optical link	5-2
5.2	Out-of-band and in-band management	5-2
	Out-of-band management	5-2
	In-band management	5-3
5.3	Switching modes between SONET and SDH	5-5
5.4	Procedure to backup and restore files on the 1830 PSS NEs	5-5
	Encrypted file transfer	5-5
	Procedure 5-2 To create a 1830 PSS backup/restore policy.....	5-6
5.5	Managing NE software upgrades	5-8
5.6	Procedures to manage NE software upgrades	5-8
	Procedure 5-3 To import device software image files to the 5620 SAM database	5-8
	Procedure 5-4 To create a software upgrade policy.....	5-9
	Procedure 5-5 To assign a software upgrade policy to an 1830 PSS.....	5-10
	Procedure 5-6 To perform an immediate software upgrade.....	5-11
	Procedure 5-7 To schedule an automatic software upgrade	5-14
	Procedure 5-8 To view the status of a software upgrade	5-15
5.7	Power Management on the 1830 PSS.....	5-15
	Technology Types	5-16
	Procedure 5-9 To create an unreserved technology type	5-16
	Procedure 5-10 To set the technology type on OCH cross connects on the 1830 PSS.....	5-17
	Procedure 5-11 To view and set target power offsets on the 1830 PSS	5-18

5.8	Policies supported on the 1830 PSS	5-18
	QoS policies	5-19
5.9	Procedures to create local 1830 PSS QoS policies	5-20
	Procedure 5-12 To create a local 1830 PSS access ingress policy.....	5-20
	Procedure 5-13 To create a local 1830 PSS network policy.....	5-22
	Procedure 5-14 To create a local 1830 PSS port access egress policy	5-23
	Procedure 5-15 To create a local 1830 PSS port scheduler policy	5-24
	Procedure 5-16 To create a local 1830 PSS network queue policy	5-25
6	1830 PSS discovery	6-1
6.1	1830 PSS device discovery	6-2
6.2	SNMP management.....	6-2
7	1830 PSS CLI sessions	7-1
7.1	1830 PSS device CLI sessions	7-2
7.2	Workflow to configure and manage CLI scripts on the 1830 PSS.....	7-2
7.3	1830 PSS CLI scripts.....	7-2
	Procedure 7-1 To create, run and schedule an 1830 PSS CLI script	7-3
8	1830 PSS equipment management	8-1
8.1	Equipment management overview	8-3
8.2	Workflow to manage the 1830 PSS equipment using the navigation tree	8-3
8.3	Workflow to manage the 1830 PSS equipment	8-4
8.4	Working with objects	8-4
	Resynchronization of objects.....	8-5
8.5	Managing ROADM OADM and Mesh connections (Degree 2+).....	8-5
8.6	Managing One-device Anydirection and Two-device Anydirection configuration connections	8-7
	One-device Anydirection configuration.....	8-7
	Two-device Anydirection configuration.....	8-8
8.7	Procedures to manage shelves	8-10
	1830 PSS-32 shelves.....	8-10
	1830 PSS-16 shelves.....	8-11
	1830 PSS-4 shelves	8-11
	1830 PSS-1 AHP shelves	8-11
	Working with shelves on the 1830 PSS	8-11
	Procedure 8-1 To view/edit a shelf	8-12
	Procedure 8-2 To configure a shelf	8-12
	Procedure 8-3 To remove a shelf	8-13
8.8	Procedures to manage card slots	8-13
	Procedure 8-4 To configure a card	8-13
	Procedure 8-5 To view or modify a card.....	8-15
	Procedure 8-6 To remove a card.....	8-15
	Dry contacts.....	8-16
	Procedure 8-7 To configure 1830 PSS dry contact sensors.....	8-16
8.9	Procedures to manage ports.....	8-16
	Procedure 8-8 To create an optical link between ports.....	8-17
	Procedure 8-9 To delete an optical link	8-18
	Port properties	8-18

	Procedure 8-10 To configure a port	8-18
	Procedure 8-11 To auto-disable a CIT port on an EC card	8-19
8.10	Performance monitoring overview	8-19
	PM process	8-20
8.11	Performance statistics	8-20
	Bins and intervals	8-20
	Statistics collection	8-21
8.12	Workflow for performance statistics collection	8-21
8.13	1830 PSS statistics procedures	8-22
	Procedure 8-12 To modify a 1830 PSS Performance Management Policy.....	8-22
	Procedure 8-13 To configure retention time for file-based statistics.....	8-23
	Procedure 8-14 To clear the 1830 PSS bins.....	8-24
8.14	PM profile types supported for line ports on amplifier cards	8-24
8.15	Procedures for TCA profiles	8-24
	TCA profiles	8-25
	Procedure 8-15 To configure thresholds for TCA profiles	8-25
	Procedure 8-16 To assign TCA profiles to an EC card or port	8-26
	Configuring PM.....	8-26
	Viewing PM data	8-26
	Cards and ports that support PM data	8-27
	Displaying PM data for an EC card	8-29
	Procedure 8-17 To enable PM TCA alerts	8-29
8.16	Procedures to configure LAGs	8-29
	Procedure 8-18 To create a LAG on an 11DPE12A card.....	8-29
	Procedure 8-19 To create a LAG on an 11QPE24 card	8-31

9 — 1830 PSS equipment navigation tree 9-1

9.1	Equipment navigation tree overview.....	9-2
	Using the 1830 PSS external element manager.....	9-2
	Procedure 9-1 To launch the 1830 PSS external EMS browser	9-2

1830 PSS network management

10 — 1830 PSS routing and forwarding 10-1

10.1	Routing and forwarding overview	10-2
	OSPFv2	10-2
	IGMPv2	10-2
10.2	Workflow to configure protocols	10-2
10.3	Routing and forwarding procedures	10-3
	Procedure 10-1 To create a Multi-area OSPFv2.....	10-3
	Procedure 10-2 To modify a Multi-area OSPFv2	10-4
	Procedure 10-3 To delete a Multi-area OSPFv2.....	10-4

11 – 1830 PSS service tunnels	11-1
11.1 Service tunnel overview.....	11-2
11.2 Ethernet (G.8032) ring protection.....	11-2
ERP	11-2
Service provisioning on Ethernet (G.8032) rings	11-3

1830 PSS optical transport service management

12 – 1830 PSS optical transport service management	12-1
12.1 Optical transport services overview.....	12-2
12.2 Y-cable protection	12-3
Y-cable support on working and protection OTs	12-3
12.3 Dual stage multiplexing	12-4
12.4 Regeneration services on the 1830 PSS	12-4
DWDM-DWDM.....	12-5
DWDM-CWDM.....	12-5
CWDM-Black & White	12-6
CWDM-FOADM.....	12-6
DWDM-Black & White	12-6
12.5 Ethernet service management	12-7
VPLS management on the 1830 PSS	12-7
Mirroring.....	12-7
12.6 Workflow to configure optical transport services.....	12-8
12.7 Procedures to configure optical transport services.....	12-8
Procedure 12-1 To create an optical transport service using configuration forms	12-8
Procedure 12-2 To create a multipoint transport service.....	12-16
Procedure 12-3 To add a drop site on an unprotected multipoint service in a 11DPM12 card	12-18
Procedure 12-4 To delete a drop site on an unprotected multipoint service in a 11DPM12 card	12-19
Procedure 12-5 To create dual stage multiplexing services on the 1830 PSS for keyed and unkeyed services	12-19
Procedure 12-6 To create single fiber bidirectional support on the 1830 PSS-4/16/32 for unkeyed services	12-20
Administrative State	12-21
Operational State	12-21
Procedure 12-7 To create an APS group	12-22
Procedure 12-8 To change the protection switch for an APS group member	12-23
Procedure 12-9 To configure a port-timeslot assignment on channelized cards	12-24
Procedure 12-10 To manually configure an ODU timeslot assignment for 11DPM12 cards	12-24
Procedure 12-11 To discover the optical transport services.....	12-26

	Procedure 12-12 To unmanage an optical transport service	12-27
	Procedure 12-13 To display services riding on external or internal optical links	12-27
12.8	Managing optical power levels using the Wavelength Tracker	12-28
	Service power graph	12-33
	Port power graph.....	12-35
12.9	Procedures to manage optical power levels	12-36
	Procedure 12-14 To display optical power levels along a service path	12-36
	Procedure 12-15 To refresh the optical power graph display	12-37
	Procedure 12-16 To configure auto power adjustment rules.....	12-37
	Procedure 12-17 To manage expected power level and deviation at a Wavelength Tracker detection point.....	12-38
	Procedure 12-18 To export optical power graph data to a CSV file	12-40
12.10	OTN Trails	12-41
	Procedure 12-19 To create an ODU trail.....	12-41
	Procedure 12-20 To delete an ODU trail.....	12-43
	Procedure 12-21 To configure an ODU trail	12-43
	Procedure 12-22 To view the optical channel usage.....	12-44
	Procedure 12-23 To create an ODUK XC on the 11DPM12 card	12-44
	Procedure 12-24 To delete an ODUK XC on the 11DPM12 card	12-45

1830 PSS maintenance using the 5620 SAM

13	—	1830 PSS troubleshooting	13-1
13.1		Troubleshooting overview	13-2
13.2		Fault management	13-2
		User activity logging	13-2
13.3		Ethernet OAM	13-3
		Ethernet CFM	13-3
13.4		Alarm management	13-4
		Alarm status, severity, and aggregation.....	13-5
		Alarm suppression.....	13-5

Getting started

- 1 – 1830 PSS overview
- 2 – 5620 SAM optical features
- 3 – 1830 PSS map management
- 4 – 1830 PSS user security

1 — 1830 PSS overview

- 1.1 Overview of the 1830 PSS 1-2**
- 1.2 Component configuration 1-5**
- 1.3 About this guide 1-5**
- 1.4 1830 PSS reference documentation 1-6**

1.1 Overview of the 1830 PSS

The 5620 SAM supports the 1830 PSS product family of devices which includes:

- 1830 PSS-32—central office device
- 1830 PSS-16—end office device
- 1830 PSS-4—edge device platform
- 1830 PSS-1—edge aggregation devices that collect lower rate signals for input to the 1830 PSS network. These include:
 - 1830 PSS-1 GBE edge device
 - 1830 PSS-1 MD4H edge device
 - 1830 PSS-1 AHP amplifier

See the chapter 5620 SAM 10.0 compatibility with 1830 PSS in the *5620 SAM Network Element Compatibility Guide* for more information on supported releases for the 1830 PSS devices.

The 1830 Photonic Service Switch (PSS) product family provides increased network flexibility and operational automation using zero-touch, transparent photonic networking. Photonic networks use simplified and accelerated operations to transform WDM into true transport networking with advanced flexibility, performance, automation, and integration.

1830 PSS-32 central office device/1830 PSS-16 end office device

The 1830 PSS-32 and 1830 PSS-16 are closely related shelves that provide multi-service and multi-reach solutions. The shelves are referred to collectively as the 1830 PSS-32/1830 PSS-16. They are scalable optical transport platforms for regional and metropolitan network transport and services delivery.

- The 1830 PSS-32 central office device provides a 32-slot platform for core, central office applications.
- The 1830 PSS-16 end office device provides a 16-slot platform that can be used for end office or smaller core office applications.

For specific information about the hardware and capabilities supported by the shelves, see the *Alcatel-Lucent 1830 Photonic Service Switch 32/16 Product Information and Planning Guide* for more information.

The 1830 PSS-32 is designed as a highly modular metropolitan WDM platform to cost-effectively meet the requirements of initial network demands while simultaneously ready for upgrade to meet future demands. At the same time, it employs advanced “Zero Touch Photonics” management and control features, simplifying WDM system management so that it approaches the ease-of-use associated only with SDH/SONET technology.

The 1830 PSS-32 network consists of single, standalone NE, or two or more interconnected NEs that provide SDH/SONET/GigE aggregation and transport, 10G, FC (R1.1), or transponderless wavelength services in a metropolitan or regional networking environment.

The 1830 PSS-32 and 1830 PSS-16 support bidirectional transmission over a single fiber. These devices can be configured to support applications using CWDM filters. Each bidirectional transmission requires different CWDM wavelengths in each direction. Bidirectional transmissions over a single fiber is supported with the following filters and OTs:

- SFC-2
- SFC-4
- SFC-8
- 4DPA4
- 11STAR1
- 11STAR1A
- 11STMM10
- 11DPE12(E)

See the *Alcatel-Lucent 1830 Photonic Service Switch 36/32/16 Product Information and Planning Guide* and the *Alcatel-Lucent 1830 Photonic Service Switch 36/32/16 (PSS-36/PSS-32/PSS-16) User Provisioning Guide* for more information.

1830 PSS-4 edge device platform

The 1830 PSS-4 edge device platform is designed for installation near the edge of the metropolitan networks. The edge device platform is designed to provide a flexible, power saving, OTN-based solution for metro and access applications. The target application provides OTN based multiple service aggregation for CWDM and DWDM networks. The application can also be configured to provide an FOADM terminal, and in-line amplifier solution for the 1830 PSS-32 networks. The platform supports non-switched and electrical switched configurations, and ensures full interworking and compatibility with other 1830 PSS product platforms.

The 1830 PSS-4 supports bidirectional transmission over a single fiber. See the *Alcatel-Lucent 1830 Photonic Service Switch 36/32/16 Product Information and Planning Guide* and the *Alcatel-Lucent 1830 Photonic Service Switch 36/32/16 (PSS-36/PSS-32/PSS-16) User Provisioning Guide* for more information.

See the *Alcatel-Lucent 1830 Photonic Service Switch 4 (PSS-4) User Guide* for more information.

1830 PSS-1 GBE edge device

The 1830 PSS-1 GBE edge device is a 1-Rack-Unit (1-RU) device for installation in 19-in., ANSI, or ETSI racks. The device is based on a 12xGBE optical transponder that supports optional coarse wavelength division multiplexing (CWDM) filters.

The 1830 PSS-1 GBE edge device provides an optimized WDM access platform that includes the following features:

- 1-RU height
- dc power (ac power adapter available)
- standard or temperature-hardened versions
 - standard 1830 PSS-1 GBE
 - hardened 1830 PSS-1 GBEH
- Black & White (B&W), CWDM, or DWDM optics
- in-band management using GCC
- stackable as a single NE

- alignment with the 1830 PSS service cards and operations
- support for single-fiber bidirectional transmission

See the *1830 Photonic Service Switch 1 (PSS-1) GBEH Edge Device User Guide* for more information.

1830 PSS-1 MD4H edge device

The 1830 PSS-1 MD4H edge device is a 1-RU device for installation in 19-in., ANSI, or ETSI racks. The MD4H designation represents the device as a multiservice dual module unit with 4 client ports per module, which is temperature hardened. The device is based on two 1830 PSS-32 4DPA4 optical transponders, which are remapped into an external device that also supports optional CWDM filters.

The 1830 PSS-1 MD4H edge device provides an optimized WDM access platform that includes the following features:

- 1-RU height
- dc power (ac power adapter available)
- standard or temperature-hardened versions
- Black & White (B&W), CWDM, or DWDM optics
- in-band management using GCC
- alignment with the 1830 PSS service cards and operations
- support for single-fiber bidirectional transmission

See the *Alcatel-Lucent 1830 Photonic Service Switch 1 (PSS-1) MD4H Edge Device User Guide* for more information.

1830 PSS-1 AHP amplifier

The 1830 PSS-1 AHP is a 1-RU edge device that supports a specially adapted amplifier. Two 1830 PSS-1 AHP devices can be used to provide a low cost in-line amplifier, or ILA, for the 1830 PSS. The 1830 PSS-1 AHP amplifier software provides the following enhanced capabilities:

- multi-shelf NE management
- IP routing (OSPF) over OSC links
- wave key assignment distribution over OSPF LSAs
- automatic/manual power management between devices
- keyed-unkeyed DWDM OCH XC provisioning and OCH trail management
- DCM shelf/card/port management

See the *Alcatel-Lucent 1830 Photonic Service Switch 1 (PSS-1) AHP Amplifier User Guide* for more information.

1.2 Component configuration

Before you can use the 5620 SAM to manage one or more 1830 PSS devices, the required 1830 PSS modules and quantities must be included in the 5620 SAM software license. See the chapter 5620 SAM component configuration of the *5620 SAM User Guide* for information about viewing and updating the license information.

1.3 About this guide

This guide provides information about how to access the 5620 SAM to configure and manage the 1830 PSS network. The 5620 SAM guides describe the GUI operations associated with each function, and indicate whether the function is available, using the OSSI. See the *5620 SAM XML OSS Interface Developer Guide* for information about using the OSSI to perform a 5620 SAM function. This guide is intended for optical network planners, administrators, and operators and is to be used in conjunction with other guides in the 5620 SAM documentation suite where management of optical devices does not differ from other network elements. Procedures that are unique to managing the 1830 PSS are included in this document and make reference to configurable parameters described in the *5620 SAM Optical Parameter Reference*.

This document describes the features, and configurations, for the 1830 PSS-32, 1830 PSS-16 and 1830 PSS-4 as well as their hardware components, NEs, and networks. See the *Alcatel-Lucent 1830 Photonic Service Switch 36/32/16 Product Information and Planning Guide* and the *Alcatel-Lucent 1830 Photonic Service Switch 4 (PSS-4) User Guide* for more information.

A high-level overview of the 1830 PSS-1 edge devices is included. For more information about the 1830 PSS-1 edge devices, see the *Alcatel-Lucent 1830 Photonic Service Switch 1 (PSS-1) GBEH Edge Device User Guide*, the *Alcatel-Lucent 1830 Photonic Service Switch 1 (PSS-1) MD4H Edge Device User Guide*, and the *Alcatel-Lucent 1830 Photonic Service Switch 1 (PSS-1) AHP Amplifier User Guide*.

This guide contains the following volumes:

- Getting started—contains the following general and system management 1830 PSS information:
 - a system overview
 - features supported
 - GUI map management
 - user security
- Device management—contains information about device functions that are not directly related to networking, such as the following:
 - device support
 - preparing devices for 5620 SAM management
 - 5620 SAM device and equipment management functions
- Network management—contains the following information about network functions:
 - general routing and forwarding

- Service management—contains information about managing customer services, such as the following:
 - service creation and configuration
 - customer and subscriber management
 - service verification, troubleshooting, and root-cause analysis
 - scheduling of routine, service-related operations
- Maintenance—contains information about fault and alarm management.

1.4 1830 PSS reference documentation

See the following documents for more information about the 1830 PSS:

- *Alcatel-Lucent 1830 Photonic Service Switch 1 (PSS-1) GBEH Edge Device User Guide*
- *Alcatel-Lucent 1830 Photonic Service Switch 1 (PSS-1) MD4H Edge Device User Guide*
- *Alcatel-Lucent 1830 Photonic Service Switch (PSS-1) AHP Amplifier User Guide*
- *Alcatel-Lucent 1830 Photonic Service Switch 4 (PSS-4) User Guide*
- *Alcatel-Lucent 1830 Photonic Service Switch User Provisioning Guide*
- *Alcatel-Lucent 1830 Photonic Service Switch Product Information and Planning Guide*
- *Alcatel-Lucent 1830 Photonic Service Switch Maintenance and Trouble-Clearing Guide*
- *Alcatel-Lucent 1830 Photonic Service Switch 32/16 (PSS-32/PSS-16) Installation and System Turn-Up Guide*
- *Alcatel-Lucent 1830 Photonic Service Switch (PSS) Safety Guide*
- *Alcatel-Lucent 1830 Photonic Service Switch (PSS) Command Line Interface Guide*
- *Alcatel-Lucent 1830 Photonic Service Switch (PSS) TL1 Commands and Messages Guide*
- *Alcatel-Lucent 1830 Photonic Service Switch (PSS) Engineering and Planning Tool User Guide*
- *Alcatel-Lucent 1830 Photonic Service Switch (PSS) Commissioning and Power Balancing Tool User Guide*

2 – 5620 SAM optical features

2.1 1830 PSS features for 5620 SAM Release 10.0 2-2

2.1 1830 PSS features for 5620 SAM Release 10.0

Table 2-1 lists the features and functions added in the 5620 SAM, Release 10.0 for 1830 PSS support. See the *5620 SAM User Guide* for more information about non-1830 PSS features and functions.

Table 2-1 5620 SAM Release 10.0 1830 PSS features

Feature	Description	Reference
Release 10.0 R7 1830 PSS features		
No Optical features have been added in this release.		
Release 10.0 R6 1830 PSS features		
No Optical features have been added in this release.		
Release 10.0 R5 1830 PSS features		
Automatic power adjustment using WR8-88	The 5620 SAM supports automatic power adjustment for a service involving a drop shelf OT of an 1830 PSS or SR that is connected to the WR8-88 card in a ROADM or AnyDirection configuration.	See Procedure 12-16 .
Optical transport service support for 7950 XRS	The 5620 SAM supports optical transport services between two 7950 XRS through one or more interconnected 1830 PSS.	See section 12.1 .
Resync indicator icon	Some of the read-only parameters in the 5620 SAM are represented by the resync icon that is beside the parameter.	See Resynchronization of objects in section 8.4 .
QoS policy support for 11QPE24 cards	The 5620 SAM supports the following QoS policies on 11QPE24 cards: <ul style="list-style-type: none"> • Service Ingress • Access Egress • Network • Network Queue • Port Scheduler 	See section 5.8 and 5.9 . See the <i>5620 SAM Optical Parameter Reference</i> and the <i>5620 SAM User Guide</i> .
11DPE12A card service support	The 5620 SAM supports the following enhancements on 11DPE12A cards: <ul style="list-style-type: none"> • Push-Pop for QinQ service stack-VLAN tagging configuration • ESNCP • configuration of SyncE • line SVID and VLAN protection 	See Procedures 8-4 and 12-1 .
LAG support	The 5620 SAM provides equipment level support for the creation of LAGs on the following cards: <ul style="list-style-type: none"> • 11DPE12A • 11QPE24 	See Procedures 8-18 and 8-19 .
MVAC service support	The 5620 SAM allows you to create a service by selecting the following on the MVAC: <ul style="list-style-type: none"> • A end - MVAC client port • Z end - MVAC client port 	See Procedure 12-1 for information about optical transport service creation.
Power management	The 5620 SAM allows you to terminate the automatic power adjustment process in the power graph window.	See Procedure 12-16

(1 of 9)

Feature	Description	Reference
OPS protection for the 100 Gb/s OT cards	The 5620 SAM supports OPS service creation on the 1830 PSS-32, Release 5.1 or later, for the following 100 Gb/s OT cards: <ul style="list-style-type: none"> • 112SNX10 • 112SNA1 • 112SCA1 • 112SCX10 	See Procedure 12-1 for information about optical transport service creation.
ESNCP support on 11DPE12 and 11DPE12E	The 5620 SAM supports lines-side ESNCP on the 11DPE12 and the 11DPE12E cards only when there are more than two line ports. The ADM supports this configuration.	See Procedure 12-1 for information about optical transport service creation.
New performance statistics counters	The following performance statistics counters are added in the 5620 SAM: <ul style="list-style-type: none"> • FECVL • FEESL • FEESL • FEUASL 	See the <i>5620 SAM Statistics Management Guide</i> .
SVAC card service support	The 5620 SAM allows you to create service by selecting the client port, C1 of the SVAC card as the termination point: <ul style="list-style-type: none"> • A end - SVAC client port • Z end - SVAC client port 	See Procedure 12-1 for information about optical transport service creation.
SubGigE Full Rate service support on 11DPE12E cards	The 5620 SAM supports the SubGigE Full Rate service on 11DPE12E cards.	See Procedure 12-1 for information about optical transport service creation.
MVAC8B cards service support	The 5620 SAM supports the following protection types on MVAC8B card: <ul style="list-style-type: none"> • Unprotected • OPS Protected <p>The 5620 SAM allows you to create service using any combination of the following cards:</p> <ul style="list-style-type: none"> • MVAC • MVAC8B • SVAC 	See chapter 8. See the <i>5620 SAM Optical Parameter Reference</i> .
Optical channel usage	The 5620 SAM allows you to view the optical channel usage.	See Procedure 12-22 See the <i>5620 SAM Optical Parameter Reference</i> .
Multipoint transport service	The 5620 SAM supports the creation of the following multipoint transport services on the 11DPM12 card based on the type of protection: <ul style="list-style-type: none"> • Unprotected • ESNCP <p>The 5620 SAM supports the addition and deletion of termination points on the drop and continue sites of the protected and the unprotected multipoint transport service. The 5620 SAM also supports the addition and deletion of drop sites on an unprotected multipoint transport service.</p>	See Procedures 12-2, 12-3, and 12-4 See the <i>5620 SAM Optical Parameter Reference</i> .
Service discovery without XC	The 5620 SAM supports service creation, deletion, and discovery without XCs.	See Procedures 12-1 and 12-11. See the <i>5620 SAM Optical Parameter Reference</i> .

(2 of 9)

Feature	Description	Reference
Electrical SDIs for 4DPA4 and 11DPM12 on 1830 PSS-4	The 5620 SAM allows provisioning of the pluggable module type “User” to support the electrical HDSDI and SDSI for 4DPA4, and the electrical HDSDI, SDSI and 3GSDI for 11DPM12 on the 1830 PSS-4.	See the <i>5620 SAM Optical Parameter Reference</i> .
Display laser bias current and laser temperature	The 5620 SAM displays the real-time laser bias current and laser temperature on TMN for the cards listed below. The values for the parameters can be refreshed by clicking Resync. <ul style="list-style-type: none"> • A2325A • AHPLG • AHPHG • 11QPA4 • 43STX4P • 11STAR1 • 43STA1P • 11DPE12E • 11DPM12 • AM212 	See the <i>5620 SAM Optical Parameter Reference</i> .
Transmission card support	The 5620 SAM supports the following transmission cards: <ul style="list-style-type: none"> • 11STAR1A • MVAC8B • 43SCX4E • 43SCGE1 • 11QPE24 • 11QPEN4 • WR2-88 • WR8-88AF • 11DPE12A 	See chapter 8. See the <i>5620 SAM Optical Parameter Reference</i> .
GCC0 channel type support on client and line ports	The 5620 SAM supports GCC0 channel type on client and line ports on the 11STAR1 card.	See Procedure 8-10. See the <i>5620 SAM Optical Parameter Reference</i> .
11STAR1A card support	The 5620 SAM supports Y-Cable, OPSA protection switching and provisioning on the 11STAR1A card on the 1830 PSS-16 and the 1830 PSS-32 devices.	See chapters 8 and 12. See the <i>5620 SAM Optical Parameter Reference</i> .
CWDM-FOADM support	The 5620 SAM supports provisioning, discovery and topological view of CWDM-FOADM in the 1830 PSS-1 GBEH and MD4H devices.	See section 12.1.
Y-cable support	The 5620 SAM supports Y-cable on the 1830 PSS-16 and 1830 PSS-32 devices for the following working and protection OT cards: <ul style="list-style-type: none"> • 43SCX4E (double width variant card) - supports only 1830 PSS-32 device • 11QPEN4 	See chapters 8 and 12.
11QPEN4 card support	The 5620 SAM supports Y-Cable, OPS, E-SNCP protection switching and provisioning on the 11QPEN4 card on the 1830 PSS-4, 1830 PSS-16, and 1830 PSS-32 devices.	See chapters 8 and 12.
11QPE24 card support	The 5620 SAM supports the following services on the 11QPE24 card on the 1830 PSS-4, 1830 PSS-16, and 1830 PSS-32 devices: <ul style="list-style-type: none"> • performance monitoring • fault management for Ethernet • OTN and FDB management 	See chapter 8. See section 12.5 for information about port mirroring. See the <i>5620 SAM User Guide</i>

(3 of 9)

Feature	Description	Reference
Extension shelves	The 5620 SAM supports up to eight extension shelves on the 1830 PSS-16.	See chapter 8.
SyncE support	The 5620 SAM supports the configuration of SyncE, with SSM enabled on the 11DPE12E card that is installed on the 1830 PSS-16, and 1830 PSS-32, Release 5.0 or later. The 5620 SAM supports the configuration of SyncE, with SSM enabled on the 11DPE12A and the 11QPE24 cards that are installed on the 1830 PSS-4, 1830 PSS-16, and 1830 PSS-32, Release 5.1 or later.	See Procedure 8-4. See the <i>5620 SAM Optical Parameter Reference</i> .
L2 ACL management	The 5620 SAM supports L2 ACL management on the 11QPE24 card on the 1830 PSS-4, 1830 PSS-16 and 1830 PSS-32 devices.	See the <i>5620 SAM User Guide</i> .
Ethernet ring protection (G.8032)	The 5620 SAM supports ethernet ring protection on the 11QPE24 card on the 1830 PSS-32, 1830 PSS-16 and 1830 PSS-4 devices. The 5620 SAM supports the automatic creation of control and data services for Ethernet (G.8032) rings. The following functionality is supported on the ERP: <ul style="list-style-type: none"> • Ethernet ring element • Ethernet ring path endpoints • Global ethernet ring • Global path elements • Service provisioning using G8032 for ethernet rings 	See section 11.2. See the <i>5620 SAM User Guide</i> . See the <i>5620 SAM Parameter Guide</i> .
IGMPv2 snooping	The 5620 SAM supports IGMPv2 snooping on the 11QPE24 card on the 1830 PSS-32, 1830 PSS-16 and 1830 PSS-4 devices.	See chapter 10. See the <i>5620 SAM User Guide</i> .
Ethernet services	The 5620 SAM supports the provisioning of Ethernet point to point and multipoint transport services across the transport network and port mirroring and creation of VPLS services on the 11QPE24 card on the 1830 PSS-32, 1830 PSS-16 and 1830 PSS-4 devices.	See section 12.5.
Ethernet OAM	The 5620 SAM supports Ethernet OAM functions on the 11QPE24 card on the 1830 PSS-32, 1830 PSS-16 and 1830 PSS-4 devices.	See section 13.3.
Release 10.0 R4 1830 PSS features No Optical features have been added in this release.		
Release 10.0 R3 1830 PSS features No Optical features have been added in this release.		
Release 10.0 R2 1830 PSS features No Optical features have been added in this release.		
Release 10.0 R1 1830 PSS features		
Transmission card support	The 5620 SAM supports the following transmission cards: <ul style="list-style-type: none"> • AM2125A • AM2318A • ITLU • MESH4 • MVAC - supports sVOA • WR8-88A • 112SNA1 • 112SNX10 • 11DPM12 • 43SCX4 • 43SCA1 	See Table 8-3. See the <i>5620 SAM Optical Parameter Reference</i> .

(4 of 9)

Feature	Description	Reference
Dedicated card support	The 5620 SAM supports the following dedicated cards on the 1830 PSS-32: <ul style="list-style-type: none"> PFDC60 (AM2) DC Power Filter (60A) on the shelf 	See Table 8-4. See the <i>5620 SAM Optical Parameter Reference</i> .
7750 SR card support	The 5620 SAM supports the following cards on the 7750 SR: <ul style="list-style-type: none"> 8-Port 10GE XFP IMM B (non-DWDM) 40GE OTU3 Long Reach DWDM Tunable IMM <p>The service flows from:</p> <ul style="list-style-type: none"> SR to SR PSS to SR SR to PSS 	See Procedure 8-8, 12-1, and chapter 10.
Shelf support	The ITLU (Unidirectional interleaver shelf) is supported on the 1830 PSS-32 and 1830 PSS-16.	See chapter 8.
Optical intrusion detection	The AM2318A and the AM 2125B cards support optical intrusion detection	See Procedure 8-4.
Multi-area OSPF	Multi-area OSPF is supported on the 1830 PSS-16 and 1830 PSS-32, Release 3.6.5 or later. You can create up to three OSPF areas in addition to the default backbone area. The areas can be modified and deleted.	See Procedures 10-1, 10-2, and 10-3.
Y-cable support	The 5620 SAM supports Y-cable protection on the following cards: <ul style="list-style-type: none"> 11DPE12 (1830 PSS-4 only), 11DPM12, 11QPA4 11STAR1, 11STGE12, 11STMM10 112SCX10, 112SNX10 43SCX4, 43STA1P, 43STX4, 4DPA4 	See Procedure 12-1.
40G coherent SONET/SDH client and 40G coherent Add/Drop pack	The 5620 SAM supports client rates for the SDH and SONET mode on the 43SCX4 and 40G on the Add/Drop pack on the 43SCA1 card.	See chapter 8. See chapter 12. See the <i>5620 SAM Optical Parameter Reference</i> .
40G Mux Coherent 8GFC	The 5620 SAM supports the 40G Mux Coherent 8GFC client rate on the 43SCX4 card.	See chapter 8. See the <i>5620 SAM Optical Parameter Reference</i> .
Dual stage multiplexing	The 5620 SAM supports dual stage multiplexing on the 1830 PSS-16 and 1830 PSS-32 shelves for keyed and unkeyed services for the following cards: <ul style="list-style-type: none"> 4DPA4 to 11STMM10 4DPA4 to 11DPM12 11DPM12 to 43STX4P 11DPM12 to 43SCX4 11DPM12 to 112SCX10 11DPM12 to 112SNX10 	See Procedure 12-5. See the <i>5620 SAM Optical Parameter Reference</i> .
ENSCP service creation	The 5620 SAM supports ENSCP service creation for the following cards and configurations: <ul style="list-style-type: none"> 4DPA2 service provisioning 4DPA4 FlexMux configurations 11QPA4 service configurations 11DPE12 Fullrate, QinQ service configurations 11DPM12 - Provisioning and management of ENSCP protection on all supporting service configurations 1830 PSS-1MD4H configurations 1830 PSS - 1GBE configurations 	See Procedure 12-1 and 12-7 to create an APS group. See the <i>5620 SAM Optical Parameter Reference</i> .

(5 of 9)

Feature	Description	Reference
ENSCP Regen	The 5620 SAM supports ENSCP Regen services.	See Procedure 12-1. See the <i>5620 SAM Optical Parameter Reference</i> .
OPS service creation	The 5620 SAM supports OPS service creation for the following cards and configurations: <ul style="list-style-type: none"> 11QPA4 	See Procedure 12-1. See the <i>5620 SAM Optical Parameter Reference</i> .
Unidirectional service support	The 5620 SAM supports unidirectional services for the following protection types: <ul style="list-style-type: none"> ENSCP Y-Cable OPS protected Diverse Route Unprotected The 5620 SAM supports unidirectional services for the following amplifier cards: <ul style="list-style-type: none"> AM2125A AM2125B AM2318A 	See Procedure 12-1. See the <i>5620 SAM Optical Parameter Reference</i> . See Table 8-3 for information on cards supported.
Single fiber bidirectional service support	The 5620 SAM supports bidirectional services on the 1830 PSS-4, 1830 PSS-16 and 1830 PSS-32 devices, for the following filter and OT card types: <ul style="list-style-type: none"> SFC-2 SFC-4 SFC-8 4DPA4 11STAR1 11STMM10 11DPE12(E) 	See Procedure 12-6. See the <i>5620 SAM Optical Parameter Reference</i> .
Auto-disable a CIT port	The 1830 PSS automatically disables the CIT interface on the 1830 PSS-16 and 1830 PSS-32 to prevent unauthorized local access.	To auto-disable the CIT port see Procedure 8-11.
Stale or invalid external optical link	The topology map on the 5620 SAM GUI enables you to view stale or invalid external optical links.	See section 5.1.
Display optical services riding on external or internal optical links	The Physical topology map on the 5620 SAM GUI enables you to display optical services riding on external or internal optical links.	See Procedure 12-13.
Service topology map view	When an 1830 PSS NE is moved on the topology map, the associated ports are moved with the NE.	See section 3.1.
Creation of a service template by clicking Apply or OK	The 5620 SAM supports creation of a service template by clicking Apply or OK before you can add optical sites and termination points.	To create a service template, see Procedure 12-1.
Backup and restore enhancement	The 5620 SAM supports enhancements on the backup and restore policy.	See Procedure 5-2.
The CIR and EIR are supported on the 11DPE12 and 11DPE12E cards	The 5620 SAM supports enhanced provision rates on the CIR and the EIR on the 11DPE12 and 11DPE12E cards.	See Procedure 12-1 and the <i>5620 SAM Optical Parameter Reference</i> .

(6 of 9)

Feature	Description	Reference
1830 PSS-4 support in Releases 3.6 and 3.6.5	Releases 3.6 and 3.6.5 of the 1830 PSS-4 device support: <ul style="list-style-type: none"> Extended Temperature Range at the NE level Expected PF Amps at the Shelf level Assigned Rate when FE is supported on the 11DPE12 and 11DPE12E cards The 1830 PSS-4, Release 3.6.5 supports the following cards: <ul style="list-style-type: none"> 4DPA2 AM2125A AM2125B AM2318A MVAC 	See chapter 8. See the <i>5620 SAM Optical Parameter Reference</i> .
Create, delete, and modify ODU trails	The 5620 SAM supports the listing of ODU and OCH trails and the creation, deletion and modification of ODU trails. OCH trails are created automatically when ODU trails are created. It also supports the inclusion of constraints for sites and ports of ODU trails in a service path. This is also supported on non-OT and non PSS ports.	See Procedure 12-19 to create an ODU trail, Procedure 12-20 to delete an ODU trail, Procedure 12-21 to modify an ODU trail. See the <i>5620 SAM Optical Parameter Reference</i> .
Full Rate LO-ODUk Service provision and discovery	The 5620 SAM supports provisioning and discovery of the LO-ODUk service on the 11DPM12 card.	See chapter 12.
Timeslot management of LO-ODUk	The 5620 SAM supports both automatic and manual configuration of timeslots for the LO-ODUk on the 11DPM12 card.	See Procedure 12-10 to configure timeslots manually for LO-ODUk. See the <i>5620 SAM Optical Parameter Reference</i> .
Create and delete ODUk cross connects on line and client ports	The 5620 SAM supports the creation of ODUk cross connects by associating line and client ports at the card and port level. The 5620 SAM supports the deletion of the ODUk cross connects on line and client ports.	See Procedure 12-23 and 12-24 and the <i>5620 SAM Optical Parameter Reference</i> .
11DPM12 - video client service	The 5620 SAM supports the 3GSDI client rate for the video client service on the 11DPM12 cards.	See Procedure 12-10 to configure these rates and the <i>5620 SAM Optical Parameter Reference</i> .
11DPM12 - FC	The 5620 SAM supports the FC 400 client rate for a service created on the 11DPM12 card.	See Procedure 12-10 to configure these rates and the <i>5620 SAM Optical Parameter Reference</i> .
11DPM12 services with OPTSG mode	The 5620 SAM supports services with Client rates - OC3/STM1, OC12/STM4 with special OPTSG mode to efficiently transport these lower rate signals on the WDM. Multiple clients can be multiplexed onto intermediate ODU1PTF containers, which results in being multiplexed onto ODU1 containers on the line side.	See Procedure 12-1 and 12-10 to create a service and configure timeslots.
WTOCM support on ILA	The 5620 SAM supports optional WTOCM on an ILA on the 1830 PSS-1 AHP. The Monitored Port Tx parameter can be configured on the Port Specifics tab for a SIG and line port.	See the <i>5620 SAM Optical Parameter Reference</i> .
Script Manager	The 5620 SAM supports creation, execution and scheduling of CLI and velocity scripts on the 1830 PSS.	See Procedure 7-1. See the <i>5620 SAM Optical Parameter Reference</i> .

(7 of 9)

Feature	Description	Reference
Power management	The 5620 SAM supports technology dependent target powers: <ul style="list-style-type: none"> Displays OCH technology types for each NE that includes WTOCM correction values Displays target power offsets by technology type for the ingress and egress direction on amp line ports Displays received technology type for an OCH cross connect Allows the user to set technology types for an OCH cross connect 	See section 5.7. See the <i>5620 SAM Optical Parameter Reference</i> .
Optical services on the OCH cross connect and on ports	You can view optical services on an OCH cross connect and on ports.	See Procedure 12-13.
License for Mesh4, WR8-88A cards, and all cards supported in this release	The 5620 SAM supports license keys for Mesh4, WR8-88A cards, and all cards supported in this release.	See section 1.2. See the <i>5620 SAM User Guide</i> .
4x25 CFP support on the 112SCA1 card	The 5620 SAM supports the pluggable module type on the 112SCA1 card (dual rate). The Pluggable Module Type and the Assigned Rate parameters can be configured on the Port Specifics tab for a client and line port.	See Procedure 8-10. See the <i>5620 SAM Optical Parameter Reference</i> .
CWDM, DWDM and Black & White regeneration configurations	The 5620 SAM supports provisioning and discovery of the following regeneration configurations: <ul style="list-style-type: none"> CWDM and Black & White DWDM and Black & White DWDM and CWDM DWDM and CWDM 	See section 12.1 and Procedure 12-1 to configure regeneration services. See the <i>5620 SAM Optical Parameter Reference</i> .
Administrative and Operational states	The 5620 SAM supports Administrative Up and Down and Operational states for the different services.	See section 12.7. See the <i>5620 SAM Optical Parameter Reference</i> .
ROADM OADM and Mesh (Degree 2+)	The 5620 SAM supports optical add or drop multiplexer in linear networks.	See section 8.5.
One-device Anydirection and Two-device Anydirection configurations	The 5620 SAM supports One-device Anydirection and Two-device Anydirection configurations on the 1830 PSS. It supports provisioning, discovery and topological views for protected and unprotected services.	See section 8.6 and Procedure 12-1.
Active Path identification	The 5620 SAM supports active paths on A to Z and Z to A directions on a protected service.	See Procedure 12-8.
SyncE support on 11DPE12E cards	The 5620 SAM supports the configuration of SyncE on 11DPE12E cards installed on 1830 PSS-4 Release 3.6, and 1830 PSS-4 Release 3.6.5 with SSM enabled, and on 1830 PSS-16 and 1830 PSS-32 Release 3.6 and later.	See Procedure 8-4. See the <i>5620 SAM Optical Parameter Reference</i> .
11DPE12E enhancements	The 5620 SAM supports the configuration of line SVID and VLAN protection on the 11DPE12E OT card.	See Procedure 12-1.
Power adjustments on OT configurations	The 5620 SAM supports service auto power adjustments for 1830 PSS OT configurations.	See section 12.9. See the <i>5620 SAM Optical Parameter Reference</i> .
NE software upgrade	When a 1830 PSS device needs a software upgrade or downgrade to applicable software version, you can use the 5620 SAM to perform an on-demand or scheduled NE software upgrade using a software upgrade policy.	See sections 5.5 and 5.6.
Release 10.0 R1 1830 PSS enhancements		

(8 of 9)

Feature	Description	Reference
Enable PM TCA alerts	The 5620 SAM supports TCA alerts when the Enable PM TCA Alerts flag is turned on.	See Procedure 8-17 .
Power graph enhancements	Enhanced the Service Path form on which the power graph is displayed.	See Procedure 12-14 and 12-16 .
Unmanage an NE	Unmanaging the NE will unmanage all optical transport services associated with it. If the service is re-discovered the name of the service will revert to the default name.	See section 5.1 .
Assign port rate on optical links	You can assign a port rate to an existing optical link if a rate has not already been assigned.	See Procedure 8-8 .

(9 of 9)

3 — 1830 PSS map management

3.1 5620 SAM network topology maps 3-2

3.2 Procedures to view optical and IP interconnections 3-2

3.1 5620 SAM network topology maps

This section describes the network topology and grouping in the 5620 SAM that applies to the 1830 PSS. The 5620 SAM uses map windows to visually represent network objects and paths. For the 1830 PSS, the 5620 SAM supports physical network topology maps. Each map displays network objects and information, and provides contextual menus to open forms that display additional information. See the *5620 SAM User Guide* for more information about network topology.

Service topology map

A service topology map is available from the Manage Services form. To view the map from the Manage Services form, choose Manage→Service→Services from the 5620 SAM main menu. Choose Optical Transport Service from the drop-down menu and list services by clicking on the Search button. The list of optical transport services are displayed. Select a service and click on the Properties tab, the properties form of the selected service opens. Click on the More Actions button and select Topology View, the service is displayed on the topology map. In this view if a particular NE is moved on the map, the associated ports are moved along with the NE.

Physical topology map

When the 5620 SAM client GUI starts, the physical topology map is open in the working panel by default. The default view displays the interconnections between IP and optical devices. The 5620 SAM allows you to filter the view to display only optical interconnections or IP interconnections. Procedure 3-1 and 3-2 describes how to view the optical interconnections and the IP interconnections on the physical topology map. See the *5620 SAM Parameter Guide* for descriptions of the parameters. For more information about network topology maps, see the *5620 SAM User Guide*.

3.2 Procedures to view optical and IP interconnections

Procedure 3-1 To view optical interconnections only

- 1 Open a physical topology map.
- 2 Click on the Filter button. The Topology Filter - Physical Topology form opens.
- 3 Choose Optical Link from the Object Filters to Add, drop-down menu.
- 4 Click on the Add object filter icon. The selected Optical Link Filter panel is displayed.
- 5 Choose Endpoint A Type from the Attribute drop-down menu.
- 6 Choose EQUALS from the Function drop-down menu.
- 7 Choose Port from the Value drop-down menu.
- 8 Click on the Add to Filter icon. The Endpoint A Type is displayed on the Filter panel.

- 9 Choose AND from the Operators drop-down menu. Repeat steps 5 to 8 to add Endpoint B Type. Endpoint B Type is also displayed on the Filter panel.
 - 10 Click on the Save button, the Save Filter dialog box is displayed.
 - 11 Enter a Filter Name and Description and click on the Save button. The filter is saved.
 - 12 Choose Network Element from the Object Filters to Add drop-down menu.
 - 13 Click on the Add object filter icon. The selected Network Element panel is displayed.
 - 14 Choose Chassis Type from the Attribute drop-down menu.
 - 15 Choose EQUALS from the Function drop-down menu.
 - 16 Choose the desired 1830 PSS chassis from the Value drop-down menu.
 - 17 Click on the Add to Filter icon. The Chassis Type is displayed on the Filter panel.
 - 18 Choose AND from the Operators drop-down menu. Repeat steps 12 to 17 to add the different 1830 PSS chassis types.
 - 19 Click on the Save button, the Save Filter dialog box is displayed.
 - 20 Enter a Filter Name and Description and click on the Save button. The filter is saved.
 - 21 Click on the Apply button to apply the Optical Link filter. The Topology Filter - Physical Topology form closes and the map view is refreshed to display only devices with optical interconnections.
-

Procedure 3-2 To view IP interconnections only

- 1 Open a physical topology map.
- 2 Click on the Filter button. The Topology Filter - Physical Topology form opens.
- 3 Choose Physical Link from the Object Filters to Add drop-down menu.
- 4 Click on the Add object filter icon. The selected Physical Link Filter panel is displayed.
- 5 Choose Chassis Type from the Attribute drop-down menu.
- 6 Choose NOT EQUAL from the Function drop-down menu.
- 7 Choose the desired 1830 PSS chassis from the Value drop-down menu.
- 8 Click on the Add to Filter icon. The 1830 PSS chassis is displayed on the Filter panel.
- 9 Choose OR from the Operators drop-down menu to add other 1830 PSS chassis types. Repeat steps 5 to 7. The 1830 PSS chassis is displayed on the Filter panel.

- 10 Click on the Save button, the Save Filter dialog box is displayed.
 - 11 Enter a Filter Name and Description and click on the Save button. The filter is saved.
 - 12 Click on the Apply button to apply the Physical Link filter. The Topology Filter - Physical Topology form closes and the map view is refreshed to display only devices with IP interconnections.
-

4 — 1830 PSS user security

4.1 User security overview 4-2

4.2 5620 SAM user and user group security 4-2

4.1 User security overview

The 5620 SAM provides security functions for user groups, devices, and paths.



Note – The administrator can restrict access of certain operators to equipment and services in their own domain, for example, transport or data.

4.2 5620 SAM user and user group security

You can use the 5620 SAM to configure user accounts, user groups, and spans of control that define the 5620 SAM objects that users can view and manage. For more information about user security in the 5620 SAM, see the *5620 SAM User Guide*.

Span of control

Span of control allows you to assign access permissions to a functional group of 5620 SAM server objects; for example a group of NEs or services.

You can use the 5620 SAM to create a span of control, or to copy an existing span of control and modify the list of associated objects to create a span of control. The objects that are in a span of control, or that can be added to a span of control, are called span objects. The 5620 SAM has several pre-defined spans of control. Each new 5620 SAM object, for example, a discovered NE, is added to the corresponding pre-defined span of control. Optical objects, such as the wavelength service on the 1830 PSS, are added to the Default Transport Span.

For more information about span of control see the *5620 SAM User Guide*.

You can filter the objects that a map or list displays, based on the user span of control. By default, the GUI displays only the objects that are in the View Access and Edit Access spans of control of the user. See the *5620 SAM User Guide* for more information.

1830 PSS device management using the 5620 SAM

- 5 – 1830 PSS device management
- 6 – 1830 PSS discovery
- 7 – 1830 PSS CLI sessions
- 8 – 1830 PSS equipment management
- 9 – 1830 PSS equipment navigation tree

5 — 1830 PSS device management

- 5.1 Device management overview 5-2**
- 5.2 Out-of-band and in-band management 5-2**
- 5.3 Switching modes between SONET and SDH 5-5**
- 5.4 Procedure to backup and restore files on the 1830 PSS NEs 5-5**
- 5.5 Managing NE software upgrades 5-8**
- 5.6 Procedures to manage NE software upgrades 5-8**
- 5.7 Power Management on the 1830 PSS 5-15**
- 5.8 Policies supported on the 1830 PSS 5-18**
- 5.9 Procedures to create local 1830 PSS QoS policies 5-20**

5.1 Device management overview

The 1830 PSS device must be commissioned and pre-configured before the 5620 SAM can manage the device. When the pre-configuration is complete, the 5620 SAM can discover the device. See the chapter Device discovery of the *5620 SAM User Guide* for more information about operations related to device discovery.

To manage or unmanage an NE, see the Device discovery procedures of the *5620 SAM User Guide* for more information.

All unmanaged NEs are displayed on the topology map of the 5620 SAM GUI as a single unmanaged NE icon. See the section Indicators and icons of the *5620 SAM User Guide* for more information.



Note – Unmanaging the NE will unmanage all optical transport services associated with it. If the service is re-discovered the name of the service will revert to the default name.

Procedure 5-1 To view an invalid or stale optical link

- 1 In the topology map double-click on the optical link which links to the Unmanaged NEs icon.
 - 2 The Physical Link Group List - UnmanagedNEs form displays a list of invalid or stale optical links, for example, optical links from a managed NE to an Unmanaged NE in 5620 SAM.
 - 3 Select an invalid or stale optical link and click on the Properties tab, the Optical Link [Edit] form opens. Information about the Managed and UnManaged NEs are displayed. The unManaged NE EndPoint attribute displays the links that leads to the unmanaged NE.
-

5.2 Out-of-band and in-band management

The 5620 SAM supports in-band and out-of-band management of devices for the 1830 PSS.

Out-of-band management

When you configure a device for out-of-band management only, management traffic between the 5620 SAM and the 1830 PSS device is transmitted through the management port of the device. The 5620 SAM sends management traffic to the management IP address of the 1830 PSS device.

When you configure a device for in-band and out-of-band management, one method provides redundancy for the other method. If the IP addresses are the same, redundancy is not supported. The out-of-band connection is called the primary connection and the in-band connection is called the secondary connection.

See the chapter Device commissioning and management of the *5620 SAM User Guide* for out-of-band management support.

In-band management

The network management system can manage an 1830 PSS-32 network by connecting to a single 1830 PSS-32 NE that is called a GNE. The GNE provides management connectivity to the other 1830 PSS-32 NEs in the network. The GNE communicates externally using an IP address. Non-GNE nodes are only in-band to each other. The network system does not specifically manage or configure the GNE.

SONET, SDH, and OTN architectures support DCC and GCC, which are in-band channels that can be used for management. IP over DCC/GCC is an in-band management channel which can be used if a device is connected to a TRX-24000 client port.

Figure 5-1 shows NE 1 as the Gateway NE for the ring, interconnecting the cards which support OSC ports between the NEs provides inter-NE communication for network management.

See the *Alcatel-Lucent 1830 Photonic Service Switch 36/32/16 (PSS-36/PSS-32/PSS-16) Installation and System Turn-Up Guide* for more information.

Figure 5-1 In-band management

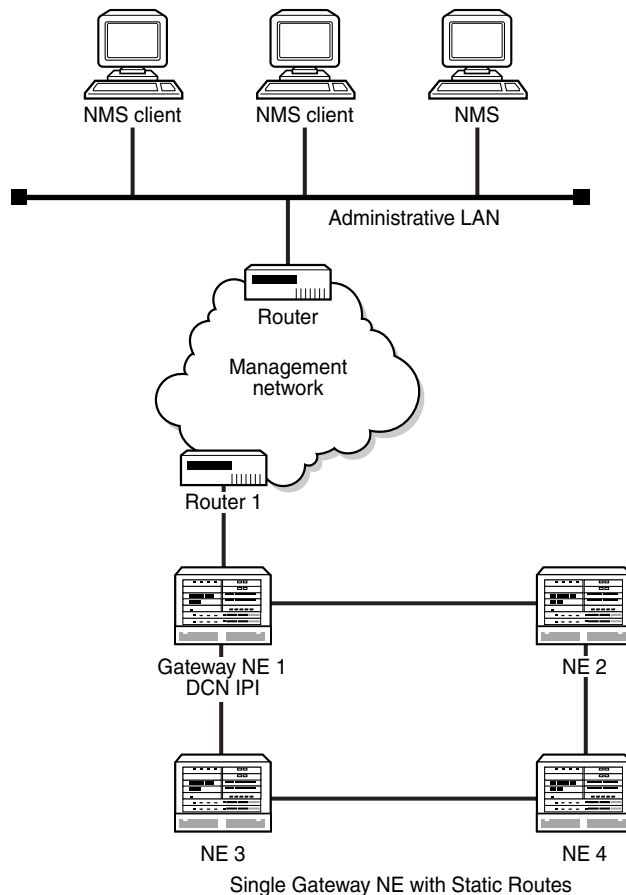

21644

Prerequisites

You must configure the following on the 1830 PSS for a gateway NE with static routes:

- OAMP IP address
- OAMP IP address subnet mask
- Default route gateway IP address (which is redistributed)
- NE loopback IP address and subnet mask
- SNMP source to be set to Loopback IP only

The non-gateway NEs require the following:

- NE loopback IP address and mask

Although the 1830 PSS NEs do not exchange routing information with operating organization routers, an operating organization router that is attached to the gateway NE requires the following:

- The operating company router must have auto-negotiation enabled, or should be running in 10Mbps half-duplex mode
- static route for the NE loopback IP address subnet

To configure the 1830 PSS to use in-band, out-of-band, or in-band and out-of-band polling at the intervals specified in a mediation policy, see the chapter Device commissioning and management of the *5620 SAM User Guide* for more information about in-band and out-of-band polling intervals. See the chapter Device discovery of the *5620 SAM User Guide* for information about configuring mediation policies.

5.3 Switching modes between SONET and SDH

The 1830 PSS can be set to SONET or SDH mode using the CLI command. You cannot change the SONET or SDH mode using the 5620 SAM GUI. If you switch modes between SONET and SDH, and the mode value is changed, you would need to do a full manual resync of the NE in the 5620 SAM GUI.

When the mode is changed using a `tnSysSonetSdhMode` CLI command, the 5620 SAM recognizes the NE mode change and raises an alarm. The alarm must be manually cleared by the user. See the *5620 SAM User Guide* to clear alarms.



Caution – If the NE mode is changed to SONET or SDH, the configurations on the shelf, card, and port NE are lost. After the NE is re-started, the new mode must be reconfigured.

5.4 Procedure to backup and restore files on the 1830 PSS NEs

Encrypted file transfer

Database backup and restore support SFTP /TFTP data transfer. The NE communicates with an external SSH server running on the database backup and software repository machine. The 5620 SAM runs on the same machine.

Any previous configurations supported in the CLI are valid for configuration software or configuration database. The option is available in the transfer protocol field, and must be used to initiate an SFTP-based transfer.

For software and database downloads, the applications running on the NE are SSH or SFTP clients which connect to an external SSH server. Authentication is password based only. Public key-based authentication is not supported. As a result, you can initiate SFTP-based database and software download operations even when an encryption key is not generated.

For more information on backup and restore, see the *5620 SAM User Guide*.

Procedure 5-2 To create a 1830 PSS backup/restore policy

When the 5620 SAM performs a device configuration backup/restore, the 1830 PSS transfers files to and from the 5620 SAM server. See the *5620 SAM Optical Parameter Reference* and the *5620 SAM Parameter Guide* to configure the parameters.



Note — The default backup policy is automatically assigned to 5620 SAM-managed NEs that do not have an assigned backup policy.

- 1 Choose Administration→NE Maintenance→Backup/Restore from the 5620 SAM main menu. The Backup/Restore form opens with the Backup/Restore Policy tab displayed.
- 2 Click on the Create button. The Backup Policy (Create) form opens.
- 3 Specify whether backup functionality is enabled.
 - a Enable the Enable Backup parameter.
 - b Disable the Enable Backup parameter. Go to step 8.
- 4 Configure the following parameters:
 - Policy ID
 - Auto-Assign ID
 - Name
 - Policy Type (1830 PSS Node)
- 5 Configure the following parameters in the Backup Triggering panel:
 - Scheduled Backup Scheme
 - Scheduled Backup Interval
 - Scheduled Backup Sync Time
 - Scheduled Backup Threshold (operations)
- 6 Configure the parameters in the Backup Purging panel:
 - Auto-Purge Scheme
 - Number of Backups
 - Maximum Backup Age (days)

7 Configure the parameters in the PSS Backup/Restore Settings panel:



Note — If SFTP is selected as the Transfer Protocol, the SFTP User ID, SFTP Password, and the Server IP parameter values need to be authenticated.

- SFTP User ID
- SFTP Password
- Transfer Protocol
 - SFTP
 - TFTP
- Server IP
- File Transfer Server Port (default)
- Root Directory
- File Compression



Note 1 — To use SFTP, an SSH server must be configured using port 22. The 5620 SAM uses port 69 for TFTP file transfers.

Note 2 — The root directory displays the server path where the file is transferred after the policy is created.

- 8 Click on the OK button to save the backup policy. The Backup Policy (Create) form closes.
- 9 Assign the policy to the 1830 PSS, as required.
- i Choose the new policy in the list and click on the Properties button. The Backup Policy (Edit) form opens.
 - ii Click on the Backup/Restore Policy Assignment tab.
 - iii Choose one or more NEs in the Unassigned Sites list and click on the right arrow key to move NEs to the Assigned Sites list.
 - iv Click on the OK button. The Backup Policy (Edit) form closes and a dialog box appears.
 - v Click on the Yes button. The policy is assigned to the NEs.
 - vi Click on the Copy button to make a copy of the Backup Policy.
- 10 Close the Backup/Restore form.
-

5.5 Managing NE software upgrades

When a 1830 PSS device needs a software upgrade or downgrade to applicable software version, you can use the 5620 SAM to perform an on-demand or scheduled NE software upgrade using a software upgrade policy. You can create and configure multiple software upgrade policies and assign them to multiple NEs. You cannot delete a software upgrade policy that is assigned to an NE. The information in a software upgrade policy includes the following:

- whether to activate the software after transferring it to the NE
- whether to reinitialize the NE after the upgrade

During a software upgrade, the 5620 SAM performs checks to ensure that the new software is compatible with the device type and that the required files are present. The 5620 SAM does not initiate a device software upgrade unless the necessary conditions are in place. You can use the 5620 SAM to roll back a software upgrade to the previous version in the event of an upgrade failure.

For more information on software upgrades, see the *Alcatel-Lucent 1830 Photonic Service Switch 36/32/16 (PSS-36/PSS-32/PSS-16) User Provisioning Guide* and the *5620 SAM User Guide*.

5.6 Procedures to manage NE software upgrades

Use the following procedures to perform 1830 PSS software upgrades.

Procedure 5-3 To import device software image files to the 5620 SAM database

- 1 Copy or move the device software to a directory that is accessible to the 5620 SAM.



Note — The directory must contain a valid and complete set of device software files.

- 2 Choose Administration→NE Maintenance→Software Upgrade from the 5620 SAM main menu. The Software Upgrade form opens with the Software Upgrade Policy tab displayed.
- 3 Click on the Software Images tab.
- 4 Click on the PSS Software Images tab.

- 5 Perform one of the following:
 - a To import image files from a local server, perform the following:
 - i Click on the Import button. The Select import PSS Software window appears.
 - ii Navigate to directory that contains the software image, select the image, and click on the Open button. The Import Image dialog box appears.
 - iii Click on the Yes button to proceed. Once the import is complete, an entry for the image appears in the list.
 - b To import 1830 PSS software from a remote location with FTP support, perform the following:
 - i Click on the Remote Path button. The Remote Path dialog box appears.
 - ii Click on the Yes button to continue. The Software Directory Path dialog box appears.
**Note** — The remote system address is the server IP that is configured on the policy of the associated NE.
 - iii Enter the complete Remote Software Path, for example, `/dir/dir/1830 PSS XX-software version`, and click on the OK button. Once the remote path import is complete, an entry for the image appears in the list.
- 6 Close the Software Upgrade form.

Procedure 5-4 To create a software upgrade policy

The 5620 SAM uses a 1830 PSS-specific software upgrade policy to download 1830 PSS software. A default 1830 PSS software upgrade policy is created when the 5620 SAM initializes.

Perform this procedure to create a policy that can be used to perform an on-demand or scheduled device software image upgrade. Contact your Alcatel-Lucent technical support representative for information about downgrades.

- 1 Perform Procedure 5-3 to import the required device software image.
- 2 Ensure that the following conditions are present.
 - Appropriate FTP accounts are configured and available on the devices.
 - The device configuration files are backed up.
- 3 Choose Administration→NE Maintenance→Software Upgrade from the 5620 SAM main menu. The Software Upgrade form opens.

- 4 Click on the Create button. The Software Upgrade Policy (Create) form opens.
 - 5 Choose the 1830 PSS Node option from the Policy Type drop-down menu.
 - 6 Configure the following parameters:
 - Auto-Assign ID
 - Policy ID
 - Name
 - 7 Configure the parameters in the PSS Based Setting panel, as required.
 - 8 Configure the following parameters, as required:
 - Force Upgrade
 - Node Backup
-  **Note** — Make sure that Backup is configured before selecting the Node Backup option. See the *Alcatel-Lucent 1830 Photonic Service Switch 36/32/16 (PSS-36/PSS-32/PSS-16) User Provisioning Guide* for more information.
- 9 Click on the Apply button. The Software Upgrade Policy (Create) form refreshes with additional tabs and the form name changes to Software Upgrade Policy (Edit).
 - 10 Close the Software Upgrade Policy (Edit) form. The new policy is displayed on the Software Upgrade form.
-

Procedure 5-5 To assign a software upgrade policy to an 1830 PSS

- 1 Choose Administration→NE Maintenance→Software Upgrade from the 5620 SAM main menu. The Software Upgrade form opens.
 - 2 Select a software upgrade policy from the list and click on the Properties button. the Software Upgrade Policy (Edit) form opens.
 - 3 Click on the Software Upgrade Policy Assignment tab. The Software Upgrade Policy (Edit) Filter form opens.
 - 4 Configure the filter parameters, if required. Click on the OK button.
 - 5 Select one or more NEs in the Unassigned Sites list and click on the right-pointing arrow to move them to the Assigned Sites list.
 - 6 Click on the OK button. A dialog box appears.
 - 7 Click on the Yes button. The policy is assigned to the NEs.
 - 8 Close the Software Upgrade Policy (Edit) form.
 - 9 Close the Software Upgrade form.
-

Procedure 5-6 To perform an immediate software upgrade

Before you proceed with this procedure, ensure that the required software images are imported to the 5620 SAM database, see Procedure 5-3, and that the node is assigned to the appropriate software upgrade policy, see Procedure 5-5.

- 1 Choose Administration→NE Maintenance→Software Upgrade from the 5620 SAM main menu. The Software Upgrade form opens.
- 2 Choose the appropriate 1830 PSS software upgrade policy.
- 3 Click on the Software Images tab.
- 4 Click on the PSS Software Images tab.
- 5 You can perform the node level upgrade steps as separate tasks using the audit, load and activate functionalities, as one task using the auto upgrade functionality, or as a scheduled task.
 - a To perform the node level upgrade steps as separate tasks go to step 6.
 - b To perform the node level upgrade steps as a single task go to step 7.
 - c To perform the node level upgrade steps as a scheduled task go to Procedure 5-7.
- 6 To perform the audit, load, and activate steps as separate tasks, proceed as follows:
 - i To audit the 1830 PSS software image, proceed as follows:
 - Choose the appropriate 1830 PSS software image from list and click on the Audit button. The Confirm Audit settings dialog box appears.
 - Choose an option from the Audit Settings drop-down menu and click on the OK button. The Audit - Select Sites form opens.

Note — If you select the Default Audit Settings option, the policy level settings will be used.

 - Select the node that you wish to audit and click on the OK button. The Audit - Select Sites form closes.
 - Click on the Software Upgrade Status tab to view the status of the audit as it progresses. Verify that the software is successfully audited before you go to step ii.



- ii To load audited software onto the device, proceed as follows:
 - Click on the Load button. The Load - Select Sites form opens displaying a list of nodes with successfully audited software.
 - Select the node where you wish to load the software and click on the OK button. The Load dialog box appears.
 - Click on the Yes button to proceed.



Note – The load operation may take considerable time to complete.

- Click on the Software Upgrade Status tab to view the status of the load as it progresses. Verify that the audited software is successfully loaded before you go to step [iii](#).

- iii To activate software that has been loaded onto the node, proceed as follows:
 - Click on Activate button. The Activate - Select Sites form opens with a list of nodes that are ready to be activated displayed.
 - Select the node where you wish to activate the software and click on the OK button. The Activate dialog box appears, informing you that activation will result in a warm reboot of the NE.
 - Click on the Yes button to proceed.



Note – The activate operation may take considerable time to complete.

- iv To go step [8](#).

- 7 To perform the audit, load, and activate steps as a single task, proceed as follows:

- i Choose the appropriate 1830 PSS software image from list and click on the Auto Upgrade button. The Confirm Audit settings dialog box appears.
- ii Choose an option from the Audit Settings drop-down menu and click on the OK button. The AutoUpgrade - Select Sites form opens.



Note – If you select the Default Audit Settings option, the policy level settings will be used.

- iii Select the node that you wish to upgrade and click on the OK button. The Audit - Select Sites form closes.
- iv Click on the Software Upgrade Status tab to view the progress.

- 8 Perform one of the following:
 - a To commit the activated software release to the node, proceed as follows:
 - i Click on Commit button. The Commit - Select Sites form opens with a list of nodes that are supported for the selected software image.



Note — You can commit the active release at any time after the software release has been activated.

- ii Select the node where you wish to commit the activated software release and click on the OK button. The Commit dialog box appears.
 - iii Click on the Yes button to proceed.
 - b To revert the node to the previously committed software release, proceed as follows:
 - i Click on Revert button. The Revert - Select Sites form opens with a list of nodes that are supported for the selected software image.



Note — You can revert to a previously committed software release at any time.

- ii Select the node where you wish to revert the software release and click on the OK button. The Revert dialog box appears.
 - iii Click on the Yes button to proceed.
 - 9 Close the Software Upgrade form.
-

Procedure 5-7 To schedule an automatic software upgrade

Perform this procedure to schedule the node level upgrade steps to occur automatically. See the *5620 SAM User Guide* for information about creating schedules. Before you proceed make sure that the required software images are imported to the 5620 SAM database, see Procedure 5-3, and that the node is assigned to the appropriate software upgrade policy, see Procedure 5-5.

- 1 Choose Administration→NE Maintenance→Software Upgrade from the 5620 SAM main menu. The Software Upgrade form opens with the Software Upgrade Policy tab displayed.
- 2 Select the appropriate software upgrade policy.



Note — The 5620 SAM performs the upgrade according to the configuration in the software upgrade policy that is assigned to the NE.

- 3 Click on the Software Images tab.
- 4 Select a software image in the list and click on the Schedule button. The Confirm Audit Settings dialog box appears.
- 5 Choose an option from the Audit Settings drop-down menu and click on the OK button. The AutoUpgrade - Select Sites form opens.



Note — If you select the Default Audit Settings option, the policy level settings will be used.

- 6 Select the node that you wish to upgrade and click on the OK button. The Select Schedule - Select Schedule form opens.
- 7 Select a schedule in the list and click on the OK button. The Schedule Upgrades dialog box appears. See the *5620 SAM User Guide* for information about creating schedules.
- 8 Click on the Yes button. The 5620 SAM schedules the upgrade.

- 9 To complete the software upgrade, perform one of the following:
 - a To commit the activated software release to the node, proceed as follows:
 - i Click on Commit button. The Commit - Select Sites form opens with a list of nodes that have activated software displayed.
 - ii Select the node where you wish to commit the activated software release and click on the OK button. The Commit dialog box appears.
 - iii Click on the Yes button to proceed.
 - b To revert the node to the previously committed software release, proceed as follows:
 - i Click on Revert button. The Revert - Select Sites form opens with a list of nodes that have activated software displayed.
 - ii Select the node where you wish to revert the software release and click on the OK button. The Revert dialog box appears.
 - iii Click on the Yes button to proceed.
 - 10 Close the Software Upgrade form.
-

Procedure 5-8 To view the status of a software upgrade

- 1 Choose Administration→NE Maintenance→Software Upgrade from the 5620 SAM main menu. The Software Upgrade form opens with the Software Upgrade Policy tab displayed.
 - 2 Select the Software Upgrade Status tab.
 - 3 Select the node from the list and click on the Properties button. The Software Upgrade Status (View) forms opens displaying 1830 PSS software upgrade script information and the current upgrade status.
-

5.7 Power Management on the 1830 PSS

Power management is set on the 5620 SAM GUI to improve transmission performance.

The 1830 PSS supports both auto and manual power management of the technology types. Auto-power managed networks have restricted topologies, but can be commissioned and the NE automatically adjusts power levels. Manual-power managed networks supports more flexible topologies, but the power levels and the commissioning can be set. For protection configurations, the working and protection lines can be both auto-power managed, both manual-power managed, or one auto-power and one manual-power managed.

TOADM and ROADM configurations support auto power management, and FOADM configurations support manual power management. There are some FOADM configurations that do support auto power management.

Technology Types

The 5620 SAM supports the creation and modification of the unreserved technology type and viewing of the reserved technology type.

There are two technology types:

- Reserved types are discovered on the node
- Unreserved types are discovered on the 5620 SAM



Note 1 – The 5620 SAM does not allow creation of a technology type if the Bit Rate Key and the Encoding Key exists.

Note 2 – The 5620 SAM does not support modification of the WTOCM Calibration for reserved enumerated values 9001-10000.

You can delete a technology type if:

- It is not a reserved type. Reserved types have OTU Bit Rate or Encoding which is equal to 1-1000, 9001-10000
- It is not associated with a cross connect
- OTU Bit Rate and Encoding do not match the AZ and ZA OTU Bit Rate and Encoding and the AZ and ZA received OTU Bit Rate and Encoding on a cross connect

Procedure 5-9 To create an unreserved technology type

- 1 Choose Equipment from the navigation tree view selector. The navigation tree displays the Equipment view.
- 2 Choose Network→NE.
- 3 Right-click on the NE and choose Properties from the contextual menu. The Network Element [Edit] form opens with the General tab displayed.
- 4 Click on the NE Specifics tab.
- 5 Choose the Technology Types tab.
- 6 Click on the Create button. The Technology Type [Create] form opens. Configure the parameters:
 - Bit Rate Key
 - Bit Rate Description
 - Encoding Key
 - Encoding Description
 - WTOCM Calibration

- 7 Click on the OK button. The Technology Type [Create] form closes.
 - 8 Click on the Close Window button. The Network Element [Edit] form closes.
-

Procedure 5-10 To set the technology type on OCH cross connects on the 1830 PSS

- 1 Choose Equipment from the navigation tree view selector. The navigation tree displays the Equipment view.
- 2 Choose Network→NE.
- 3 Right-click on the NE and choose Properties from the contextual menu. The Network Element [Edit] form opens with the General tab displayed.
- 4 Click on the NE Specifics tab.
- 5 Choose the OCH Cross Connect tab. Select a Cross Connect and click on the Properties tab.
- 6 The OCH Cross Connect [Edit] form opens.
- 7 Choose Select in the User Technology AZ panel or the User Technology ZA panel. The Select Bit Rate / Encoding AZ or ZA OCH Cross Connect form opens.
- 8 Select the technology type that you want to associate with the cross connect and click on the OK button.
- 9 Click on the OK button. The Technology Type [Create] form closes.
- 10 Click on the Close Window button. The Network Element [Edit] form closes.



Note 1 – The Received Technology type is automatically received by the cross connect depending on the type of technology, either CWDM or DWDM.

Note 2 – The 5620 SAM does not allow creation of a technology type if the Bit Rate Key and the Encoding Key exists.

Procedure 5-11 To view and set target power offsets on the 1830 PSS



Note 1 – The following ports support target power offset:

- A2325A, AHPHG, AHPLG, ALPHG, AM2017B and AM2325B LINE ports
- AM2125A, AM2125B, AM2318A and RA2P LINEIN ports (Ingress only)
- AM2125A, AM2125B and AM2318A LINEOUT ports (Egress only)

Note 2 – Target power offset depends on the ingress and egress direction of the port.

See the *Alcatel-Lucent 1830 Photonic Service Switch 36/32/16 (PSS-36/PSS-32/PSS-16) User Provisioning Guide* for more information.

- 1 Choose Equipment from the navigation tree view selector. The navigation tree displays the Equipment view.
 - 2 Choose Network→NE→Shelf→Card→Port.
 - 3 Right-click on the port and choose Properties from the contextual menu. The Physical Port [Edit] form opens with the General tab displayed.
 - 4 Click on the Port Specifics tab and choose Target Power Offset tab to configure the target power offset for each channel in each direction.
 - 5 Choose Properties, the Power Offset [Edit] form appears.
 - 6 Configure the Target Power Offset (dB) parameter.
 - 7 Click on the OK button. The Target Power Offset tab is displayed.
 - 8 Click on the Apply button to save the changes. A dialog box is displayed.
 - 9 Click in the Yes button to save the changes.
 - 10 Click on the Close Window button. The Physical Port [Edit] form closes.
-

5.8 Policies supported on the 1830 PSS



Note 1 – You can create and distribute global policies to the 1830 PSS using the 5620 SAM policy distribution framework. You cannot distribute to a specific 11QPE24 card, the global policy is distributed to all 11QPE24 cards on the 1830 PSS node. See the *5620 SAM User Guide* for more information.

Note 2 – You can create, modify, or delete local policies on the Policies tab of the 11QPE24 card properties form. See section [5.9](#).

QoS policies

The 5620 SAM supports the following types of 1830 PSS QoS policies:

- Access Ingress
- Port Access Egress
- Network
- Network Queue
- Port Scheduler

For QoS policies procedures, see QoS policies chapter in the *5620 SAM User Guide*.

Table 5-1 describes the types of 1830 PSS 11QPE24 QoS policies and the policy characteristics.

Table 5-1 1830 PSS QoS policies

Policy type	Applied to	Description	Menu Option
7210 and 1830 Access Ingress	Access SAP	Defines up to 18 forwarding class meters and meter parameters for traffic classification. Defines match criteria to map flows to the meters based on any one of the criteria (IP or MAC).	Policies→QoS→SROS QoS→Access Ingress→7210 and 1830 Access Ingress See Procedure “To configure a 7210 SAS or 1830 PSS access ingress policy” in the <i>5620 SAM User Guide</i> for information about how to configure the global policy.
7210 and 1830 Network	Uplink port	Defines ingress dot1p to forwarding class mapping and profile state. Defines the egress queuing parameters associated with each forwarding class.	Policies→QoS→SROS QoS→Network→7210 and 1830 Network. See Procedure “To configure a 7210 SAS or 1830 PSS network policy” in the <i>5620 SAM User Guide</i> for information about how to configure the global policy.
7210 and 1830 Network	Network port	Defines ingress dot1p or DSCP value mapping to forwarding classes. Defines unicast meters. Only unicast meters with range 1-8 are allowed. Defines the egress forwarding class to dot1p or DSCP value markings. Remarking of QoS bits.	Policies→QoS→SROS QoS→Network→7210 and 1830 Network. See Procedure “To configure a 7210 SAS or 1830 PSS network policy” in the <i>5620 SAM User Guide</i> for information about how to configure the global policy.
7210 and 1830 Network Queue	Uplink port	Defines forwarding class mappings to network queues and queue characteristics for the queues	Policies→QoS→SROS QoS→Network Queue→7210 and 1830 Network Queue. See Procedure “To configure a 7210 SAS or 1830 PSS network queue policy” in the <i>5620 SAM User Guide</i> for information about how to configure the global policy.
7210 and 1830 Port Scheduler	Access and uplink ports	Defines the parameters for the port scheduler	Policies→QoS→SROS QoS→Scheduler→7210 and 1830 Port Scheduler. See Procedure “To configure a 7210 SAS or 1830 PSS port scheduler policy” in the <i>5620 SAM User Guide</i> for information about how to configure the global policy.

5.9 Procedures to create local 1830 PSS QoS policies

The following procedures describe how to create local 1830 PSS QoS policies on the 11QPE24 card.

Procedure 5-12 To create a local 1830 PSS access ingress policy

- 1 Choose Equipment from the view selector in the navigation tree. The navigation tree displays the Equipment view.
- 2 Locate and expand the 1830 PSS on which you need to create the access ingress policy.
- 3 Expand the shelf icon on which the 11QPE24 card is located.
- 4 Right-click on the 11QPE24 card icon and choose Properties from the contextual menu. The Card Slot (Edit) form opens with the General tab displayed.
- 5 Click on the Policies tab. The Access Ingress tab is displayed.
- 6 Click on the Create button. The SAP Access Ingress, Local Policy (Create) form opens with the General tab displayed.
- 7 Configure the parameters:
 - ID
 - Auto-Assign ID
 - Displayed Name
 - Description
 - Scope
 - Number of QoS Classifiers
 - Default FC
- 8 Click on the Meter tab.
 - i Click on the Create button. The Meter, SAP Access Ingress (Create) form opens with the General tab displayed.
 - ii Configure the parameters:
 - ID
 - Rate Mode
 - MultiPoint
 - iii Click on the CIR/PIR tab and configure the parameters.
 - CIR Adaptation
 - PIR Adaptation
 - CIR (kbps)
 - PIR (kbps)
 - iv Click on the OK button to save the changes. A dialog box appears.
 - v Click on the OK button. The Meter, SAP Access Ingress (Create) form closes.

- 9 Click on the Forwarding Classes tab.
 - i Click on the Create button. The Forwarding Class, SAP Access Ingress (Create) form opens.
 - ii Configure the parameters:
 - Forwarding Class
 - Meter ID
 - Multicast Meter ID
 - Broadcast Meter ID
 - Unknown Meter ID
 - iii Click on the OK button to save the changes. A dialog box appears.
 - iv Click on the OK button. The Forwarding Class, SAP Access Ingress (Create) form closes.
- 10 Perform one of the following:
 - a Click on the IP Match Criteria tab to configure IP match criteria.
 - i Click on the Create button. The IP Match, SAP Access Ingress (Create) form opens.
 - ii Configure the parameters:
 - ID
 - Displayed Name
 - Description
 - Forwarding Class
 - DSCP
 - iii Click on the OK button to save the changes. A dialog box appears.
 - iv Click on the OK button. The IP Match, SAP Access Ingress (Create) form closes.
 - b Click on the MAC Match Criteria tab.
 - i Click on the Create button. The MAC Match, SAP Access Ingress (Create) form opens.
 - ii Configure the parameters:

• ID	• Source MAC
• Displayed Name	• Destination MAC
• Description	• Dot1p
• Forwarding Class	• Ether Type
 - iii Click on the OK button to save the changes. A dialog box appears.
 - iv Click on the OK button. The MAC Match, SAP Access Ingress (Create) form closes.

- 11 Click on the Ok button to save the policy. The SAP Access Ingress, Local Policy (Create) form closes.
 - 12 Close the Card Slot (Edit) form.
-

Procedure 5-13 To create a local 1830 PSS network policy

- 1 Choose Equipment from the view selector in the navigation tree. The navigation tree displays the Equipment view.
- 2 Locate and expand the 1830 PSS on which you need to create the network policy.
- 3 Expand the shelf icon on which the 11QPE24 card is located.
- 4 Right-click on the 11QPE24 card icon and choose Properties from the contextual menu. The Card Slot (Edit) form opens with the General tab displayed.
- 5 Click on the Policies tab. The Access Ingress tab is displayed.
- 6 Click on the Network tab.
- 7 Click on the Create button. The Network Policy, Local Policy (Create) form opens with the General tab displayed.
- 8 Configure the parameters:
 - Nw Mgr ID
 - Auto-Assign ID
 - ID
 - Auto-Assign ID
 - Displayed Name
 - Description
 - Scope
 - Default FC
 - Default FC Profile
 - Remarking
- 9 Click on the Egress Forwarding Classes tab.
- 10 Choose a forwarding class and click on the Properties button. The Egress Forwarding Class, Network Policy (Create) form opens.
- 11 Configure the parameters:
 - Dot1p In Profile
 - Dot1p Out Profile
- 12 Click on the OK button. The Egress Forwarding Class, Network Policy (Create) form closes and a dialog box appears.
- 13 Click on the OK button.
- 14 Map the dot1p tag of the ingress traffic to the ingress queue ID, if required.
 - i Click on the Ingress Dot1p tab.
 - ii Click on the Create button. The Network Ingress Dot1p, Network Policy (Create) form opens.

- iii Configure the parameters:
 - Dot1p
 - Forwarding Class
 - Profile
 - iv Click on the OK button to close the form. The policy form reappears with the newly created object displayed.
 - v Repeat step 13 for each new rule that you need to add. You can configure up to eight rules.
- 15 Click on the OK button.
 - 16 Click on the Ok button to save the policy. The Network Policy, Local Policy (Create) form closes.
 - 17 Close the Card Slot (Edit) form.
-

Procedure 5-14 To create a local 1830 PSS port access egress policy

- 1 Choose Equipment from the view selector in the navigation tree. The navigation tree displays the Equipment view.
- 2 Locate and expand the 1830 PSS on which you need to create the port access egress policy.
- 3 Expand the shelf icon on which the 11QPE24 card is located.
- 4 Right-click on the 11QPE24 card icon and choose Properties from the contextual menu. The Card Slot (Edit) form opens with the General tab displayed.
- 5 Click on the Policies tab. The Access Ingress tab is displayed.
- 6 Click on the Port Access Egress tab.
- 7 Click on the Create button. The Port Access Egress Policy, Local Policy (Create) form opens with the General tab displayed.
- 8 Configure the parameters:
 - ID
 - Auto-Assign ID
 - Displayed Name
 - Description
 - Scope
- 9 Click on the Queues tab.
- 10 Choose a queue and click on the Properties button. The PortAccessEgressQueue (Edit) form opens with the General tab displayed.

- 11 Configure the parameters:
 - ID
 - Displayed Name
 - Description
 - 12 Click on the CIR/PIR tab and configure the parameters:
 - CIR Adaptation
 - PIR Adaptation
 - CIR (kbps)
 - PIR (kbps)
 - 13 Click on the OK button. A dialog box appears.
 - 14 Click on the OK button. The PortAccessEgressQueue (Edit) form closes.
 - 15 Repeat steps 10 to 14 to configure additional queues.
 - 16 Click on the Forwarding Classes tab.
 - 17 Click on the Create button. The Network Egress Forwarding Class (Create) form opens.
 - 18 Configure the parameters:
 - Forwarding Class
 - In Profile
 - Out Profile
 - 19 Click on the OK button. A dialog box appears.
 - 20 Click on the OK button. The Network Egress Forwarding Class (Edit) form closes.
 - 21 Click on the OK button. The Port Access Egress Policy, Local Policy (Create) form closes and a dialog box appears.
 - 22 Click on the OK button.
 - 23 Close the Card Slot (Edit) form.
-

Procedure 5-15 To create a local 1830 PSS port scheduler policy

- 1 Choose Equipment from the view selector in the navigation tree. The navigation tree displays the Equipment view.
- 2 Locate and expand the 1830 PSS on which you need to create the port scheduler policy.
- 3 Expand the shelf icon on which the 11QPE24 card is located.
- 4 Right-click on the 11QPE24 card icon and choose Properties from the contextual menu. The Card Slot (Edit) form opens with the General tab displayed.

- 5 Click on the Policies tab. The Access Ingress tab is displayed.
 - 6 Click on the Port Scheduler tab.
 - 7 Click on the Create button. The Port Scheduler, Local Policy (Create) form opens with the General tab displayed.
 - 8 Configure the parameters:
 - Displayed Name
 - Description
 - Mode
 - 9 Click on the OK button. The Port Scheduler, Local Policy (Create) form closes and a dialog box appears.
 - 10 Click on the OK button.
 - 11 Close the Card Slot (Edit) form.
-

Procedure 5-16 To create a local 1830 PSS network queue policy

- 1 Choose Equipment from the view selector in the navigation tree. The navigation tree displays the Equipment view.
- 2 Locate and expand the 1830 PSS on which you need to create the network queue policy.
- 3 Expand the shelf icon on which the 11QPE24 card is located.
- 4 Right-click on the 11QPE24 card icon and choose Properties from the contextual menu. The Card Slot (Edit) form opens with the General tab displayed.
- 5 Click on the Policies tab. The Access Ingress tab is displayed.
- 6 Click on the Network Queue tab.
- 7 Click on the Create button. The Network Queue, Local Policy (Create) form opens with the General tab displayed.
- 8 Configure the parameters:
 - Displayed Name
 - Description
- 9 Click on the Queues tab.
- 10 Choose a queue and click on the Properties button. The NQueueEntry (Edit) form opens with the General tab displayed.

- 11 Configure the parameters:
 - ID
 - Displayed Name
 - Description
 - 12 Click on the Select button in the Queue Management Policy panel. The Select Queue Management Policy form opens.
 - 13 Choose a queue management policy and click on the OK button. The Select Queue Management Policy form closes and the queue policy information is displayed.
 - 14 Configure the parameters in the Port Parent panel:
 - Port Parent
 - Weight
 - CIR Level
 - 15 Click on the CIR/PIR tab and configure the parameters:
 - CIR Adaptation
 - PIR Adaptation
 - CIR (kbps)
 - PIR (kbps)
 - 16 Click on the OK button. A dialog box appears.
 - 17 Click on the OK button. The NQueueEntry (Edit) form closes.
 - 18 Repeat steps 10 to 14 to configure additional queues.
 - 19 Click on the OK button. A dialog box appears.
 - 20 Click on the OK button. The Network Queue, Local Policy (Create) form closes and a dialog box appears.
 - 21 Click on the OK button.
 - 22 Close the Card Slot (Edit) form.
-

6 — 1830 PSS discovery

6.1 1830 PSS device discovery 6-2

6.2 SNMP management 6-2

6.1 1830 PSS device discovery

The 5620 SAM discovers the 1830 PSS devices and reconciles their properties with the contents of the database. The 5620 SAM discovers the devices using SNMP. During the discovery process, the IP address used to discover a device is the Loopback IP address, also called the system ID, and the management is considered in-band. When the IP address used to discover the device is the management IP address of the device management port, the management is considered out-of-band. See chapter 5 for more information about in-band and out-of-band management.



Note – Before device discovery, ensure that the SNMP Source attribute of the 1830 PSS device is set to Loopback IP only.

To discover the 1830 PSS devices, you must use the 5620 SAM Discovery Manager to create discovery rules and scan the network as specified by the rules.

See Device discovery procedures in the *5620 SAM User Guide* for more information about how to:

- discover devices
- manage and unmanage a device
- configure NE mediation

6.2 SNMP management

The 1830 PSS-32/1830 PSS-16 supports the following SNMP functions:

- provisioning interface for equipment and parameters using SNMP v2c and v3
- alarm and trap reporting
- trap destination definition

For information about the 1830 PSS SNMP support, see the *1830 Photonic Service Switch 36/32/16 Product Information and Planning Guide* and the *1830 Photonic Service Switch 36/32/16 User Provisioning Guide*. For information about SSH security, see the chapter Device discovery of the *5620 SAM User Guide*.

To configure admin SNMP users using the CLI or the WebUI, see the *1830 Photonic Service Switch (PSS-1) Command Line Interface Guide* or the *1830 Photonic Service Switch 36/32/16 User Provisioning Guide*, for more information.



Note – The 5620 SAM supports SNMP v1, v2c, and v3 to manage the 1830 PSS nodes.

7 – 1830 PSS CLI sessions

- 7.1 1830 PSS device CLI sessions 7-2
- 7.2 Workflow to configure and manage CLI scripts on the 1830 PSS 7-2
- 7.3 1830 PSS CLI scripts 7-2

7.1 1830 PSS device CLI sessions

You can perform most NE management functions using the 5620 SAM client GUI. The functions that require CLI access to a managed NE include:

- validating GUI configuration actions
- configuring items that cannot be configured using the GUI; for example, creating a community on the NE
- troubleshooting using device debug files

The 5620 SAM client GUI provides CLI access to the managed NEs from the main menu, and from NE contextual menus in topology maps and navigation trees. See the chapter Device CLI sessions of the *5620 SAM User Guide* and the *1830 Photonic Service Switch (PSS-1) Command Line Interface Guide* for more information.

7.2 Workflow to configure and manage CLI scripts on the 1830 PSS

This workflow describes the high-level task to create, run, and schedule CLI scripts for the 1830 PSS. Use the 5620 SAM GUI to:

- 1 create a CLI script
- 2 run a CLI script
- 3 schedule a CLI script

See Procedure [7-1](#) for more information.

7.3 1830 PSS CLI scripts

Perform Procedure [7-1](#) to create, run, and schedule an 1830 PSS CLI script. See the *5620 SAM Optical Parameter Reference* for more information about configuring parameters.

As a prerequisite to Procedure [7-1](#), you need to change the username and password in the mediation policy. See the *5620 SAM User Guide* for more information about the mediation policy.

Procedure 7-1 To create, run and schedule an 1830 PSS CLI script



Warning — Scripts that are not correctly created or applied can cause serious damage to the network. Alcatel-Lucent recommends that system administrators clearly define user responsibilities for CLI script usage, and ensure that the scripts are verified and validated before they are run on devices in a live network.

- 1 Choose Tools→Scripts from the 5620 SAM main menu. The Script Manager form opens.
- 2 Choose CLI Script (Scripting) from the object drop-down menu and click on the Create button. The CLI Script [Create] form opens with the General tab displayed.
- 3 Configure the parameters:
 - Auto-Assign Id
 - Script ID
 - Name
 - Description
 - Type
 - Use Latest Version
 - Save Results from Manual Execution
 - State
 - Continue on Command Failure
 - Content Type

Enable the Use Latest Version parameter to associate all of the targets of the script with the latest version of the CLI script.

You can set the Content Type parameter to one of the following:

- CLI
- Velocity



Note — If you choose Velocity, you can import a script by clicking on the Import button in the right panel of the Script Manager form.

- 4 Specify the script target types.
 - i Click on the Add button in the NE Types panel. The Select Property - CLI Script form opens.
 - ii Choose Alcatel-Lucent 1830 PSS type and click on the OK button. The Select Property - CLI Script form closes, and the NE type is listed in the CLI Script [Create] form.
- 5 Click on the Apply button to apply the configuration.
- 6 Click on the Versions tab.
- 7 Click on the Create button to create a script. The Script Editor *script_name* form opens.

- 8 Create a version for a set of commands that must be executed on the 1830 PSS. The following commands can be created:
 - show version—displays the device software release information
 - show xc brief —lists the cross-connects on the NE
 - whoami—lists the user that is logged in to the NE
- 9 Click on the Targets tab.
- 10 Click on the Create button. The Target Configuration form opens.
- 11 Click on the Add button, to add the target on which the created script must be run. The Select Network Elements form opens.
- 12 Choose the target and click on the OK button. The selected target is displayed on the Target Configuration form.
- 13 Click on the OK button. The target is created and the CLI Script [Edit] form is displayed.
- 14 Perform one of the following in the right panel to run the script:
 - a Click on the Execute button. The script is executed.
 - b Click on the Schedule button. The Script Scheduled Task [Create] form is displayed.
- 15 Perform the following to schedule a script:
 - i Configure the parameters:
 - Scheduled Task Name
 - Scheduled Task Description
 - Save Results
 - Administrative State
 - ii From the Schedule panel, click on the Select button. The Select Schedule - Script Scheduled Task form opens.
 - iii Click on the Create button. The SAM Schedule [Create] form is displayed.
 - iv Configure the parameters in the Information, Time Settings, Schedule Settings, and Frequency Settings panel.
 - v Click on the OK button. The Select Schedule - Script Scheduled Task form opens.
 - vi Select the schedule task and click on the Properties button. The Script Scheduled Task [Create] form opens.
 - vii Click on the Apply button. The schedule is created and will run at the scheduled time.
 - viii After the schedule is created, the Schedule tab is displayed on the CLI Script [Edit] form which displays the schedule information.

- 16 Click on the Show Results button to view the results of the executed script or the scheduled script.



Note — The executed script is displayed as N/A in the Schedule column. The scheduled script displays the information about the Schedule manager and the script.

- 17 Close the CLI Script [Edit] form.
 - 18 Close the Script Manager list form.
-

8 — 1830 PSS equipment management

- 8.1 Equipment management overview 8-3**
- 8.2 Workflow to manage the 1830 PSS equipment using the navigation tree 8-3**
- 8.3 Workflow to manage the 1830 PSS equipment 8-4**
- 8.4 Working with objects 8-4**
- 8.5 Managing ROADM OADM and Mesh connections (Degree 2+) 8-5**
- 8.6 Managing One-device Anydirection and Two-device Anydirection configuration connections 8-7**
- 8.7 Procedures to manage shelves 8-10**
- 8.8 Procedures to manage card slots 8-13**
- 8.9 Procedures to manage ports 8-16**
- 8.10 Performance monitoring overview 8-19**
- 8.11 Performance statistics 8-20**
- 8.12 Workflow for performance statistics collection 8-21**
- 8.13 1830 PSS statistics procedures 8-22**

8.14 PM profile types supported for line ports on amplifier cards 8-24

8.15 Procedures for TCA profiles 8-24

8.16 Procedures to configure LAGs 8-29

8.1 Equipment management overview

The 5620 SAM equipment management interface consists of:

- a main menu
- contextual menus
- a navigation tree
- managed objects
- property forms to configure object parameters

The 5620 SAM is used to create, configure, and manage a device with the various child objects that need to be part of a network. Equipment, for example, the routers, which are at the top of the hierarchy, have properties that are configured using the CLI and are discovered when the 5620 SAM discovery process is run.

After the device is discovered, you use properties forms to configure specific parameters for the child objects of the discovered device, using the 5620 SAM navigation tree. See the Device Management section of the *5620 SAM User Guide* for more information on device management.

8.2 Workflow to manage the 1830 PSS equipment using the navigation tree

This workflow is used to manage the 1830 PSS device using the navigation tree. For more information, see the Device Management section in the *5620 SAM User Guide*.

- 1 Use the 5620 SAM to discover the 1830 PSS device.
- 2 From the Discovered NEs topology group in the Equipment view of the navigation tree, choose List from the contextual menu, or double-click on the Discovered NEs icon on the topology map to open the Discovered NEs form.
- 3 Drag and drop the 1830 PSS NE to the network icon in the equipment view of the navigation tree or to the topology map.
- 4 Open the contextual menu on the 1830 PSS device in the navigation tree and choose an option. See the *5620 SAM User Guide* for a list of contextual menu options.
- 5 Perform any of the following, as required.
 - a Modify the device parameters, as required, using the Properties option from the contextual menu.
 - b Create card objects in the shelf using the Properties option from the contextual menu in the Equipment view. See section 8.8 for more information.

- c View the parameters of the port objects that were created automatically with the daughter card object using the Properties option from the contextual menu in the Equipment view. See section 8.9 for more information.
- d Modify the parameters of the created objects, as required, using the Properties option from the contextual menu in the Equipment view.

8.3 Workflow to manage the 1830 PSS equipment

This workflow is used to manage the 1830 PSS device. For more information, see the Device Management section in the *5620 SAM User Guide*.

- 1 Verify that the 1830 PSS devices are configured before they are discovered by the 5620 SAM.
- 2 Access the 1830 PSS device and begin configuration and management.

From the 5620 SAM, Manage→Equipment→Equipment, Manage Equipment form, network administrators and operators can:

- filter different views and information for the managed devices
- view and use a graphical representation of the shelf to configure equipment
- view objects and get statistical information about the NEs in their administrative domain
- view the services that traverse or terminate on equipment
- provision and pre-provision equipment to prepare the equipment for the creation of subscriber services
- view, configure, monitor the state of, and manage the following physical elements of the hardware:
 - a managed device
 - each device has one physical shelf
 - internal and external storage devices (flash memory)
 - physical links
 - Current OLC State
- configure network and access policies for network objects, for example, ingress buffer policies for a port
- view and manage APS groups
- manage hardware fault conditions

8.4 Working with objects

Objects in the 5620 SAM are considered to have parent/child relationships that are contained within a hierarchy. For example, a card in a card slot is the parent object of a daughter card. The parameters for each object are configured for a specific function. The parameters can be managed to meet the needs of the service. Objects are created and managed using the properties forms from the contextual menus of the equipment view.

The network is the top object in the navigation tree. The device object is the discovered device at the top of the hierarchy in the navigation tree, directly below the network icon. The child objects are created automatically in the navigation tree after the device is discovered.

Resynchronization of objects

The Resync option of the contextual menu specifies that SNMP MIB and CLI information bases are reread to synchronize them with the 5620 SAM, which also synchronizes the network management settings with the device. The changes in the values for some of the read-only parameters from the 1830 PSS are not updated automatically. These parameters are identified by the resync icon that is beside the parameters. To view the updated values of the parameters, click on the resync icon.

8.5 Managing ROADM OADM and Mesh connections (Degree 2+)

The ROADM OADM (degree 2) faces both the east and west directions. Some traffic from the optical lines may be added or dropped and at least one single wavelength passed through transparently. This configuration can be used as an optical add or drop multiplexer in linear networks.

The WR8-88A supports up to degree 5 mesh connections without the need for additional mesh cards. For this connectivity, the mesh output port (MESHOUT{1-3}) of a WR8-88A card is connected directly to the add input port (ADDIN{1-8}) of another WR8-88A. Three mesh outputs are required for degree 5 connectivity. See Table 8-1 for more information.

The ROADM OADM Mesh (degree 3 through 8) faces more than 2 line directions. Individual channels come in from one line and may be added or dropped or transit transparently to any one of the other lines.



Note – If the 1830 PSS-32 network contains WR8-88A and CWR cards, use the ‘Exclusion’ option in the Path Constraints tab, to accelerate the path search and transport service creation. See Procedure 12-1 for more information.

See the *Alcatel-Lucent 1830 Photonic Service Switch Product Information and Planning Guide* for more information.

Table 8-1 ROADM-2 Degree 8 ROADM Connectivity

From Port	To Port	From	To
WR1 DROPOUT	-	-	ITLU+SFD
WR1 THRU Out	-	-	WR2 THRU In
WR1 MESHOUT1	-	-	WR3 ADDIN3
WR1 MESHOUT2	-	-	WR4 ADDIN3
WR1 MESHOUT3	MESH4 SIGIN	MESH4 SIGOUT1	WR5 ADDIN3
WR1 MESHOUT3	MESH4 SIGIN	MESH4 SIGOUT2	WR6 ADDIN3
WR1 MESHOUT3	MESH4 SIGIN	MESH4 SIGOUT3	WR7 ADDIN3

(1 of 3)

From Port	To Port	From	To
WR1 MESHOUT3	MESH4 SIGIN	MESH4 SIGOUT4	WR8 ADDIN3
WR2 DROPOUT	-	-	ITLU+SFD
WR2 THRU Out	-	-	WR1 THRU In
WR2 MESHOUT1	-	-	WR3 ADDIN4
WR2 MESHOUT2	-	-	WR4 ADDIN4
WR2 MESHOUT3	MESH4 SIGIN	MESH4 SIGOUT1	WR5 ADDIN4
WR2 MESHOUT3	MESH4 SIGIN	MESH4 SIGOUT2	WR6 ADDIN4
WR2 MESHOUT3	MESH4 SIGIN	MESH4 SIGOUT3	WR7 ADDIN4
WR2 MESHOUT3	MESH4 SIGIN	MESH4 SIGOUT4	WR8 ADDIN4
WR3 DROPOUT	-	-	ITLU+SFD
WR3 THRU Out	-	-	WR4 THRU In
WR3 MESHOUT1	-	-	WR1 ADDIN3
WR3 MESHOUT2	-	-	WR2 ADDIN3
WR3 MESHOUT3	MESH4 SIGIN	MESH4 SIGOUT1	WR5 ADDIN5
WR3 MESHOUT3	MESH4 SIGIN	MESH4 SIGOUT2	WR6 ADDIN5
WR3 MESHOUT3	MESH4 SIGIN	MESH4 SIGOUT3	WR7 ADDIN5
WR3 MESHOUT3	MESH4 SIGIN	MESH4 SIGOUT4	WR8 ADDIN5
WR4 DROPOUT	-	-	ITLU+SFD
WR4 THRU Out	-	-	WR3 THRU In
WR4 MESHOUT1	-	-	WR1 ADDIN4
WR4 MESHOUT2	-	-	WR2 ADDIN4
WR4 MESHOUT3	MESH4 SIGIN	MESH4 SIGOUT1	WR5 ADDIN6
WR4 MESHOUT3	MESH4 SIGIN	MESH4 SIGOUT2	WR6 ADDIN6
WR4 MESHOUT3	MESH4 SIGIN	MESH4 SIGOUT3	WR7 ADDIN6
WR4 MESHOUT3	MESH4 SIGIN	MESH4 SIGOUT4	WR8 ADDIN6
WR5 DROPOUT	-	-	ITLU+SFD
WR5 THRU Out	-	-	WR6 THRU In
WR5 MESHOUT1	-	-	WR1 ADDIN5
WR5 MESHOUT2	-	-	WR2 ADDIN5
WR5 MESHOUT3	MESH4 SIGIN	MESH4 SIGOUT1	WR3 ADDIN5
WR5 MESHOUT3	MESH4 SIGIN	MESH4 SIGOUT2	WR4 ADDIN5
WR5 MESHOUT3	MESH4 SIGIN	MESH4 SIGOUT3	WR7 ADDIN7
WR5 MESHOUT3	MESH4 SIGIN	MESH4 SIGOUT4	WR8 ADDIN7
WR6 DROPOUT	-	-	ITLU+SFD
WR6 THRU Out	-	-	WR5 THRU In
WR6 MESHOUT1	-	-	WR1 ADDIN6
WR6 MESHOUT2	-	-	WR2 ADDIN6

(2 of 3)

From Port	To Port	From	To
WR6 MESHOUT3	MESH4 SIGIN	MESH4 SIGOUT1	WR3 ADDIN6
WR6 MESHOUT3	MESH4 SIGIN	MESH4 SIGOUT2	WR4 ADDIN6
WR6 MESHOUT3	MESH4 SIGIN	MESH4 SIGOUT3	WR7 ADDIN8
WR6 MESHOUT3	MESH4 SIGIN	MESH4 SIGOUT4	WR8 ADDIN8
WR7 DROPOUT	-	-	ITLU+SFD
WR7 THRU Out	-	-	WR8 THRU In
WR7 MESHOUT1	-	-	WR1 ADDIN7
WR7 MESHOUT2	-	-	WR2 ADDIN7
WR7 MESHOUT3	MESH4 SIGIN	MESH4 SIGOUT1	WR3 ADDIN7
WR7 MESHOUT3	MESH4 SIGIN	MESH4 SIGOUT2	WR4 ADDIN7
WR7 MESHOUT3	MESH4 SIGIN	MESH4 SIGOUT3	WR5 ADDIN7
WR7 MESHOUT3	MESH4 SIGIN	MESH4 SIGOUT4	WR6 ADDIN7
WR8 DROPOUT	-	-	ITLU+SFD
WR8 THRU Out	-	-	WR7 THRU In
WR8 MESHOUT1	-	-	WR1 ADDIN8
WR8 MESHOUT2	-	-	WR2 ADDIN8
WR8 MESHOUT3	MESH4 SIGIN	MESH4 SIGOUT1	WR3 ADDIN8
WR8 MESHOUT3	MESH4 SIGIN	MESH4 SIGOUT2	WR4 ADDIN8
WR8 MESHOUT3	MESH4 SIGIN	MESH4 SIGOUT3	WR5 ADDIN8
WR8 MESHOUT3	MESH4 SIGIN	MESH4 SIGOUT4	WR6 ADDIN8

(3 of 3)

8.6 Managing One-device Anydirection and Two-device Anydirection configuration connections

One-device Anydirection configuration

For this configuration, the Add drop block and the connection block are on the same device. The configuration that can be used is the Mesh card (optional) with WR8, WR8-88A and CWR8-88 cards.



Note – Service provisioning, discovery and topological views are supported for protected and unprotected services for One-device Anydirection and Two-device Anydirection configurations. See Procedure [12-1](#) for more information.

Figure 8-1 Two-device Anydirection connectivity

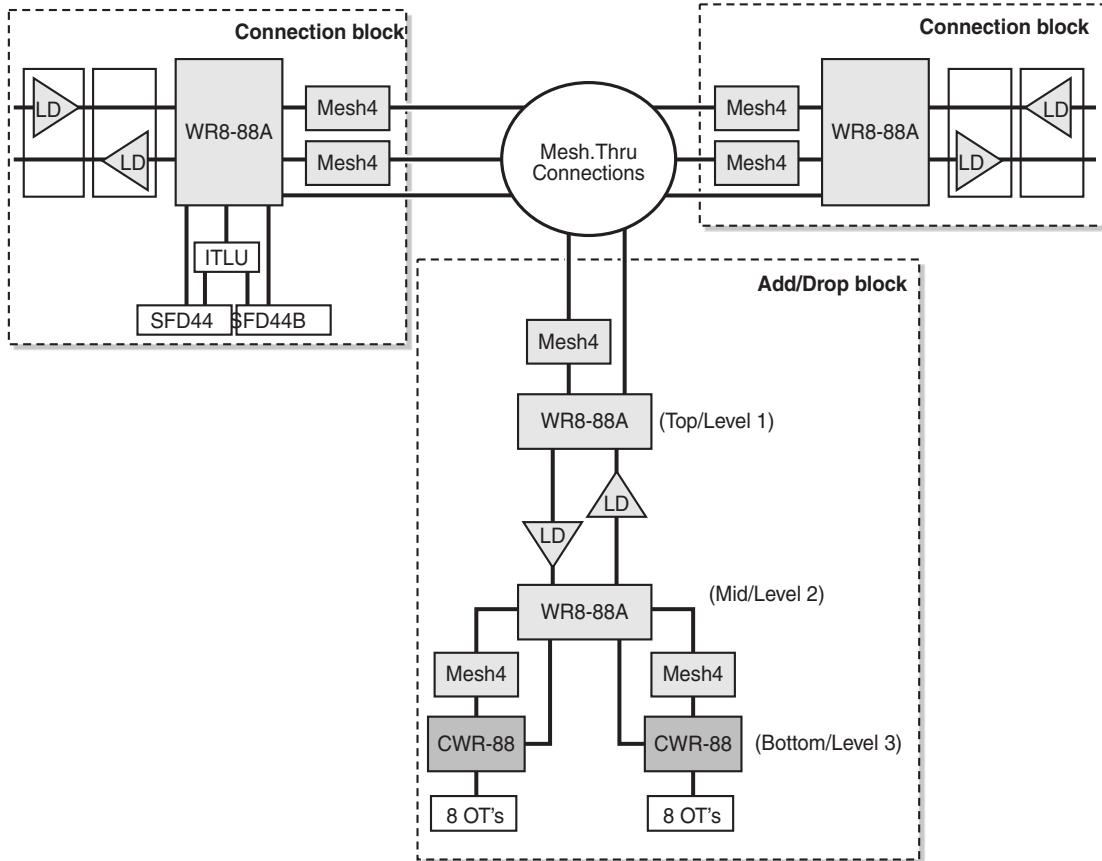

22925

Two-device Anydirection configuration

Two-device Anydirection configuration is supported on two devices for Add and Drop blocks at the terminal on one device and connection blocks on the other device. The following configurations are supported in the Add and Drop blocks and the connection blocks.



Note – Regeneration is possible inside the Add and Drop blocks.

Two devices with no MESH4 card in Add path

With this configuration, the limitations in degrees are:

- $N \leq 5$ with configuration not allowing in-service upgrade to higher degrees
- $N \leq 4$ with configuration allowing in-service upgrade to higher degrees

Figure 8-2 Two devices with no MESH4 card support

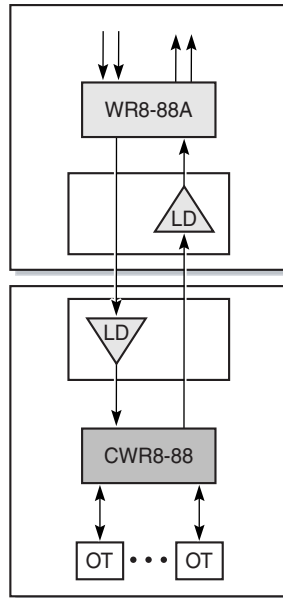

22923

Two devices with one MESH4 card in Add path

This Add and Drop block allows a configuration up to degree 8+2.

Figure 8-3 Two devices with one MESH4 card support

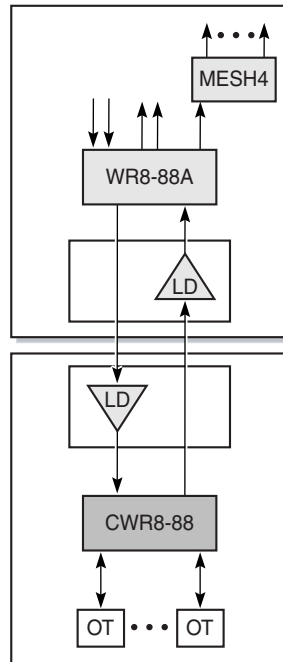

22924

8.7 Procedures to manage shelves

The 1830 PSS-32 and 1830 PSS-16 shelves provide the framework for the configuration of the 1830 PSS-32 / 1830 PSS-16 NEs. A universal shelf provides card slots, fiber management trays, backplane, power distribution, and cooling for the NE. The NEs can be deployed in a shelf or expanded to multiple interconnected universal shelves.

The first universal shelf of an NE becomes the master shelf, which provides the management and control connections to the operations systems for the cluster of shelves in a multi-shelf NE. Expansion shelves connect to the master self using a protected internal LAN communication link. The shelves provide extended slot capacity managed by the database that resides in the master shelf.

The universal shelf is the basic building block for the 1830 PSS-32 NE. The shelf provides a framework for the active modules in a system (for example, the controller and interface cards).

Each universal shelf has a shelf ID number that can be configured using a physical mechanism (for example, a rotary dial) on the backplane. Up to eight bits of information can be set. The shelf ID determines the identity of each universal shelf in the cluster. The most significant bit of the rotary dial determines whether the shelf is the main shelf or an extension shelf.

Each shelf contains mandatory modules equipped; some of the shelves can also have optional modules equipped.

The mandatory equipment must be automatically provisioned regardless of whether the equipment is present. Each shelf includes the following mandatory equipment:

- one shelf controller (EC) in slot 1 or 18
- two power modules (PF)
- a fan module (FAN)

The user interface panel (USRPNL) is mandatory and can only reside on the main shelf. Mandatory equipment is provisioned without an AINS state. The AINS allows newly provisioned entities to be inserted at a later time without generating alarms. If mandatory equipment is not installed, alarms are generated.

A DCM enclosure can hold up to 16 DCMs. The system manages each DCM as a separate shelf.

See the Alcatel-Lucent *1830 Photonic Service Switch Product Information and Planning Guide* and the Alcatel-Lucent *1830 Photonic Service Switch User Provisioning Guide* for more information. See the *5620 SAM Optical Parameter Reference* for more information on parameters.

1830 PSS-32 shelves

The 1830 PSS-32 system supports four types of shelves: Universal, DCM, ITLB, and ITLU. The 1830 PSS-32 universal shelf contains 32 replaceable slots.

The SFD44 (44-channel DWDM static filter) is modelled as an OMD shelf with a SFD44 card. Other shelves that can be configured from 5620 SAM are, SFD40, SFD40B, SFD44B and ITLB.

The DCM and OMD shelves are passive module shelves that can contain DCMs and SFD44 modules. These modules provide dispersion compensation and the optical mux/demux function that is associated with core optics modules (line drivers and CWR8, respectively) that are installed in the universal shelf. Each 1830 PSS-32 NE includes up to 8 universal shelves, and up to 24 DCM and OMD shelves.

Each 1830 PSS-32 universal shelf contains 32 function card slots. Two additional slots are reserved for controller cards that are configured for redundant control. Two more slots are reserved for the power filter cards. The top of the shelf contains a fan tray for cooling, a customer interface panel, and two timing interface cards that provide a redundant connection to synchronization references. See the *Alcatel-Lucent 1830 Photonic Service Switch Product Information and Planning Guide* and the *Alcatel-Lucent 1830 Photonic Service Switch User Provisioning Guide* for more information.

1830 PSS-16 shelves

In addition to the slots for the two power filters and two controller cards, the 1830 PSS-16 shelf contains 16 function card slots. The 1830 PSS-16 supports four types of shelves: PSS 16, DCM, ITLB, ITLU. The slots at the top of the shelf can hold two function cards or the user interface panel on units that are used as main shelves. A fan tray for cooling is located at the bottom of the shelf. The 5620 SAM supports up to eight extension shelves. See the *Alcatel-Lucent 1830 Photonic Service Switch Product Information and Planning Guide* and the *Alcatel-Lucent 1830 Photonic Service Switch User Provisioning Guide* for more information.

1830 PSS-4 shelves

The 1830 PSS-4 provides a modular platform with four universal slots that can be used for cards that support ILAs and various FOADM and terminal configurations. The 1830 PSS-4 supports DCM shelves. The 1830 PSS-4 shelf is two RU high and can be mounted in EIA, ETSI, or WECO racks. See the *Alcatel-Lucent 1830 Photonic Service Switch 4 (PSS-4) User Guide* for more information about the 1830 PSS-4 shelves.

1830 PSS-1 AHP shelves

The 1830 PSS-1 AHP system supports two types of shelves: Universal and DCM.

Working with shelves on the 1830 PSS

Shelf objects represent the hardware that is configured on a shelf. When you choose the shelf object in the navigation tree and click on Properties in the contextual menu, you can view the following information about the shelf:

- general information
- fan tray state and speed
- power supply tray statuses
- LED statuses
- card slots
- hardware environment information
- timing
- statistics
- dry contacts
- faults
- port segregation
- software control module
- software bank information
- cross connects

Procedure 8-1 To view/edit a shelf

- 1 Choose Equipment from the navigation tree view selector. The navigation tree displays the Equipment view.
- 2 Choose Network→NE→Shelf.
- 3 Right-click on the Shelf and choose Properties. The Shelf [Edit] form is displayed.
- 4 Click on the relevant tabs to view or edit shelf information.

See the *5620 SAM Optical Parameter Reference* and the *5620 SAM Parameter Guide* for more information.

Procedure 8-2 To configure a shelf



Note – During the creation of an ITLB shelf, one ITLB card slot is automatically provisioned.

- 1 Choose Equipment from the navigation tree view selector. The navigation tree displays the Equipment view.
- 2 Choose Network→NE.
- 3 Right-click on the NE and choose Configure Shelf. The Shelf, Configure Shelf, [Create] form opens.
- 4 Configure the parameters:
 - Name
 - Shelf Description
 - Serial NumberSelect:
 - Shelf Type
 - AINS Enabled
 - Expected PF Amps
 - Shelf ID
- 5 Click on the OK button. The Shelf, Configure Shelf, [Create] form closes.

See the *5620 SAM Optical Parameter Reference* for more information.

Procedure 8-3 To remove a shelf

- 1 Choose Equipment from the navigation tree view selector. The navigation tree displays the Equipment view.
 - 2 Choose Network→NE.
 - 3 Right-click on the shelf and choose Remove Shelf. A dialog box opens.
 - 4 Click on View Dependencies, an Information form displays the dependencies that will affect the removal of the shelf.
 - 5 Select “I understand the implications of this action” check box and click on Yes. The shelf is removed from the network object.
-

8.8 Procedures to manage card slots

This section describes the procedures for slot and card-level provisioning. The 5620 SAM GUI supports view, modify, create, and delete card-level functions, and the pre-provisioning of a card in an empty slot. For transmission cards supported on the universal shelf, see Table 8-3 for more information. For dedicated cards required to boot the 1830 PSS, see Table 8-4 for more information. See the *5620 SAM Optical Parameter Reference* for more information on parameters.



Note 1 – You must use filler blanks in slots that are not used to ensure proper airflow and cooling.

Note 2 – To provision two-slot height cards and two-slot width cards, the adjacent slots must be empty.

Procedure 8-4 To configure a card

- 1 Choose Equipment from the navigation tree view selector. The navigation tree displays the Equipment view.
- 2 Select an empty slot from the equipment tree to provision a card. Choose Network→NE→Shelf→Card Slot (EMPTY), OK.
- 3 Right-click on the Card Slot (EMPTY) and choose Configure Card. The Card Slot [Create] form opens.
- 4 Configure the parameters on the General tab:
 - Assigned Card Type
 - Assigned Card Sub Type
 - Current OLC State
 - Revert OLC State

- 5 Configure the parameters on the Card Specifics tab for Amplifier cards. See the *5620 SAM Optical Parameter Reference Guide* for more information.

- Card Details panel
- Ethernet Loopback



Note — Only 11DPE12A cards support Ethernet Loopback.

- Temperature panel
- Optical Intrusion Detection

Prerequisite: To provision these parameters, an external topological link should be configured on a line port.

- Monitoring Enabled
- Baseline Span Loss (dB)
- Loss Threshold (dB)
- Polling Period (seconds)
- Clear Optical Intrusion Detected Alarm



Note 1 — Only 11DPE12 cards support the following Card Rate Mode:

- FullRate
- SubRate
- QinQ

Note 2 — Only 11DPE12E cards support the following Card Rate Mode:

- QinQ

Note 3 — Only AM2318A and the AM 2125B cards support Optical Intrusion Detection.

- 6 To configure SyncE, configure the parameters on the Card Specifics tab. See the *5620 SAM Optical Parameter Reference Guide* for more information.



Note — The following cards that are installed on the 1830 PSS-4, 1830 PSS-16, or 1830 PSS-32 NE support SyncE:

- 11DPE12A
- 11DPE12E
- 11QPE24

- Click on the Line Timing tab.
- Choose a Line Reference from the list and click on the Properties button. The LineReference [Edit] form displays.
- Configure the parameters. Table 8-2 lists the ports and line references for the 11DPE12A and the 11DPE12E cards.

Table 8-2 Line references and ports

Cards	Ports	Line reference
11DPE12A	C{1-12}	Line Ref 0
	C{1-12}	Line Ref 1
	L1	Line Ref 2
	L2	Line Ref 3
11DPE12E	C{1-4, 9-12}	Line Ref 0
	C{5-8}	Line Ref 1
	L1	Line Ref 2
	L2	Line Ref 3

- iv Click on the OK button to save the changes. The LineReference [Edit] form closes.
 - v Click on the General tab.
 - vi Configure the parameters in the System Timing panel.
- 7 Click on the OK button to save the changes. The Card Slot [Create] form closes.

Procedure 8-5 To view or modify a card

- 1 Choose Equipment from the navigation tree view selector. The navigation tree displays the Equipment view.
- 2 Right-click on the card to be modified and choose Properties. The Card Slot [Edit] form is displayed.
- 3 Modify the parameters, as required. Click on the OK button to save the changes and exit the Card Slot [Edit] form.

Procedure 8-6 To remove a card

- 1 Choose Equipment from the navigation tree view selector. The navigation tree displays the Equipment view.
 - 2 Right-click on the card to be removed and choose Remove Card.
 - 3 A dialog box opens. Select the “I understand the implications of this action” check box and click Yes. The card is removed from the navigation tree.
-

Dry contacts

Dry contact refers to a contact of a relay that does not make or break a current. Usually another relay or device starts or stops the current. For example, a reed relay matrix switch is usually switched with all contacts dry. After the contacts are connected, a wire spring relay connects a supervisory scan point through which the current flows.

Procedure 8-7 To configure 1830 PSS dry contact sensors

- 1 Choose Equipment from the navigation tree view selector. The navigation tree displays the Equipment view.
 - 2 Choose Network→NE→Shelf→Card Slot (USRPNL - User Interface Panel)
 - 3 Right-click on the card slot and choose Properties. The Card Slot (User Interface Panel) [Edit] form is displayed.
 - 4 Click on the External Control tab. Choose a dry contact ID from the list. Double-click on the dry contact ID. The DryContact [Edit] form is displayed for the selected ID.
 - 5 Configure the following parameters:
 - Control Status (Choose one of the following options.)
 - Operate
 - Raman APR
 - Release
 - Control Type
 - Slot ID (only if Raman APR is selected)
 - 6 Click on the OK button. The DryContact [Edit] form closes.
 - 7 Click on the OK button. The Card Slot User Interface Panel [Edit] form closes.
-

8.9 Procedures to manage ports

The 5620 SAM supports a physical topology view that allows you to create a fiber connection by selecting two ports on the displayed shelves. The connection can be made between two ports on the same or different shelves.



Note — You can create a fiber connection only with ports that are not already part of a fiber connection.

For an interface (that is a shelf, slot, or port), you can specify that the interface is:

- connected to another on the network element
- connected to an external within or outside of the 1830 PSS network
- unconnected

To define the network topology, you first configure the fiber topology on each network element in the network. You can then connect the external interfaces on each of the network elements to create the network.

Procedure 8-8 To create an optical link between ports

- 1 Perform one of the following to create an optical link between two ports on the same shelf:
 - a Choose Create→Equipment→Optical Link.
 - b Click on Network→NE→Shelf→Card→Port (Select two ports, use the Ctrl key or the Shift key to select the second port) and right-click on the selected ports and choose Create Optical Link.
- 2 The Optical Link [Create] form opens.
- 3 Configure the parameters:
 - Name
 - Direction
 - Endpoint A - Port
 - Endpoint B- Port



Note — When you choose two ports from the Equipment tree, the port properties are automatically populated for endpoint A and B.

- 4 If a rate has not been assigned to the endpoint A port, choose an option from the Assigned Rate drop-down menu in the Endpoint A - Port panel.
 - 5 If a rate has not been assigned to the endpoint B port, choose an option from the Assigned Rate drop-down menu in the Endpoint B - Port panel.
 - 6 Click on the OK button to save the changes and exit the Optical Link [Create] form.
-

Procedure 8-9 To delete an optical link

- 1 Perform one of the following to delete an optical link:
 - a Choose Manage→Equipment→Equipment. The Manage Equipment form opens.
 - i Choose Optical Link (Optical Specifics) from the Filter for Object Type drop-down menu.
 - ii Click on the Search button. The search result displays the connected ports.
 - iii Choose the optical link ports that you need to delete and click on the Delete button. The optical link between two ports is deleted.
 - b From the Physical Topology - Network view:
 - i Double-click on an optical link.
 - ii The Physical Link Group List form opens.
 - iii Choose the port that you need to delete
 - iv Click on the Delete button.
 - 2 The optical link between the selected ports is deleted.
-

Port properties

To configure time slots on ports, see Procedure 12-9 and the *5620 SAM User Guide* for more information.

To configure a port on an 1830 PSS device based on the relevant port, follow Procedure 8-10. See the *5620 SAM Optical Parameter Reference* for more information.

The CIT interface can be configured to auto-disabled after the 1830 PSS is installed. To auto-disable the CIT port see Procedure 8-11. See the *Alcatel-Lucent 1830 Photonic Service Switch User Provisioning Guide* for more information.

Procedure 8-10 To configure a port

- 1 Choose Equipment from the navigation tree view selector. The navigation tree displays the Equipment view.
- 2 Right-click on the device where you want to configure a port and select Properties from the contextual menu. The Network Element (Edit) form opens with the General tab displayed.
- 3 On the Network Element (Edit) form navigation tree, expand the Shelf icon.
- 4 Expand to the port level and click on a port object. The Physical Port (Edit) form opens with the General tab displayed.

- 5 Configure the General tab parameters.
 - 6 Configure the Port Specifics tab parameters based on the port that needs to be configured.
 - 7 Click on the States tab and configure the Administrative State parameter.
 - 8 Click on the other tabs in the properties form to view and edit additional port information.
 - 9 Click on the OK button. The Physical Port (Edit) form closes.
-

Procedure 8-11 To auto-disable a CIT port on an EC card

- 1 Choose Equipment from the navigation tree view selector. The navigation tree displays the Equipment view.
- 2 Choose Network→NE→Shelf→Card Slot (EC: Equipment Controller Card)→Port CIT (Local Ethernet Port).
- 3 Right-click on the Card and select Properties. The Physical Port [Edit] form opens.
- 4 Click on the Port Specifics tab and select the Auto-Disable port Status panel.
- 5 Enter the 5620 SAM server IP in the Source IP field and click on Apply. The Disable Port Automatically check box is enabled. Select the check box and click on Apply. The CIT port is disabled for local access.



Note — As long as the 1830 PSS can reach the 5620 SAM server the CIT port remains in the disabled state. The 1830 PSS will check the communication link between the 5620 SAM server every 30 seconds. If the server is unreachable, the NE will wait for 300 seconds before the CIT port is enabled for local access.

8.10 Performance monitoring overview

PM refers to the in-service, non-intrusive monitoring of transmission quality and equipment health. The 1830 PSS tracks the signal quality and equipment health through continuous collection and analysis of performance data. The user can retrieve current and past values for an overview of the health of the system. The PM capability applies to optical lines, channels, and equipment. The user has the ability to provision threshold parameters to the level of performance degradation.

Proactive maintenance refers to following up on a performance degradation before a failure and alarms are raised. Reactive maintenance refers to following up on a system alarm. Crossing a performance parameter threshold indicates a potential network quality or performance degradation while the transported services are not impacted. If performance degradation continues, alarms are raised to resolve or repair the problem.

PM statistics are collected for all service cards and for all interface ports that perform OEO conversions or protection switching. The statistics are grouped by functional category. Each category has several monitored parameters for which you can configure TCAs. A threshold is the mechanism for generating a notification in response to changes in PM parameter values. The 1830 PSS allows you to provision performance parameter thresholds, which can be set by the user to indicate degraded performance. You can configure how much data is collected, how the data is stored, and how and when you are notified if generic thresholds levels are crossed. For information about performance management requirements see the *Alcatel-Lucent 1830 Photonic Service Switch User Provisioning Guide* and the *Alcatel-Lucent 1830 Photonic Service Switch Product Information and Planning Guide*.

PM process

The 1830 PSS provides the following PM processing functions:

- monitors and accumulates digital and analog parameters for a physical or logical access point
- stores and manages history accumulation data; up to thirty three 15-minute and seven 24-hour accumulation registers can be stored
- validates threshold crossing processing
- manages threshold values by assigning to profile port entities
- uses free-running counters for monitored points

PM functions are performed on physical and logical points within the 1830 PSS devices that represent the boundary with other devices or an external system. A user can define and monitor QoS at individual points in which a local NE interacts with other network entities.

8.11 Performance statistics

The 5620 SAM can be configured to collect statistics counters from 1830 PSS devices and 5620 SAM servers.

The 5620 SAM supports the following for 1830 PSS devices:

- assign the default 1830 PSS Performance Management Policy to the 1830 PSS device and enable the policy by setting the Administrative State to Up.
- specify a retention period in the Statistics Policy which indicates the period after which the statistics records are removed from the database.
- collect scheduled statistics using TFTP to view historical statistics by selecting the required PM group and clicking on the Search button.
- collect on-demand statistics using SNMP polling to view historical and real-time statistics by clicking on the Collect or Collect All button.

Bins and intervals

The performance parameters groups obtained during the parameter processing are collected in registers over measurement periods of 15 minutes and 24 hours. The collection of registers associated with a PM group and collection period is called a bin.

On 1830 PSS device

The 15-minute bins collect data at quarterly time intervals (00,15,30, 45) of the 1830 PSS clock. The 24-hour bins collect data from midnight to midnight based on UTC, not the local time. At the end of each 15-minute time interval, the contents of the 15-minute bin is transferred to the previous 15-minute bin. The 15-minute bins are then initialized to zero and a new record is initiated. Each PM group consists of thirty three 15-minute bins and seven 24-hour bins. When the storage capacity of thirty three 15-minute bins is reached, the oldest of the bins are dropped. The 24-hour bins operate in the same manner.

1830 PSS statistics storage on the 5620 SAM server

The 1830 PSS statistics are stored in the following directory on the 5620 SAM server:

```
/opt/5620sam/server/nms/tftp_home/stats
```

The files are retained for 24 hours by default. The bins can be cleared by configuring the number of bins to be cleared for each interval. See Procedure 8-14.

Statistics collection

The file-based statistics are collected from the files on the 1830 PSS devices using TFTP. The statistics are available for scheduled collection and enables viewing the historical statistics.

The MIB-based statistics are collected from the 1830 PSS MIBs using SNMP polling. The statistics are available for on-demand collection and enables viewing the real-time and historical statistics.

Scheduled and on-demand statistics are stored in the 5620 SAM database for a configurable retention period, as specified in Procedure 8-13, and are available to the 5620 SAM operators. When the retention period elapses, the statistics are removed from the database.

Statistics collected for real-time display are available only for the duration of the session and for the operator who initiates the session. Real-time statistics are not stored in the 5620 SAM database.

The 5620 SAM allows you to back up statistics data to another location. See procedure, “To back up the 5620 SAM database using the client GUI” in the *5620 SAM User Guide* for information about how to back up the 5620 SAM database.

8.12 Workflow for performance statistics collection

- 1 Modify 1830 PSS Performance Management Policy to assign 1830 PSS devices to the policy and enable the policy by setting the Administrative State to Up. See Procedure 8-12.
- 2 Specify the retention time for a statistics record. See Procedure 8-13.

- 3 Collect and display the statistics values in a current statistics record. See Procedure “To view on-demand statistics” in the *5620 SAM Statistics Management Guide* for information about viewing on-demand statistics.
- 4 Configure real-time and historical statistics graph. See Procedure “To configure and plot a statistics graph” in the *5620 SAM Statistics Management Guide* for information about creating a real-time and historical statistics graph.
- 5 Use the 5620 SAM-O interface to retrieve the performance statistics records from the 5620 SAM for processing by a third-party application. See the *5620 SAM XML OSS Interface Developer Guide* for information about using the 5620 SAM-O to transfer statistics records from the 5620 SAM database to an OSS client application.

8.13 1830 PSS statistics procedures

Perform the procedures in this section to configure the 5620 SAM for 1830 PSS statistics collection.

Procedure 8-12 To modify a 1830 PSS Performance Management Policy

- 1 Choose Tools→Statistics→Optical Performance Management Policies from the 5620 SAM main menu. The Optical Performance Management Policies form opens.
- 2 Choose the default 1830 PSS performance management policy and click on the Properties button. The 1830 PSS Performance Management Policy [Edit] form opens with the 1830 PSS Performance Management Policy tab displayed.
- 3 Configure the parameter, Administrative State.



Note — The default value for the Administrative State parameter is Down for an 1830 PSS Performance Management Policy. Set the Administrative State parameter to Up to activate statistics collection.

- 4 Click on the Apply button. A dialog box is displayed.
- 5 Click on Yes to confirm the action.
- 6 Click on the 1830 PSS Elements tab.
- 7 Configure the filter criteria, if required, and click on the Search button to generate a list of 1830 PSS elements that are already assigned to the 1830 PSS performance management policy.
- 8 Click on the Assign 1830 PSSs button. The Assign and Assign Filter forms open.
- 9 Configure the filter criteria, if required, and click on the OK button to close the Assign Filter form and return to the Assign form.
- 10 Use the right and left arrows in the center of the form to move the 1830 PSS devices between the Unassigned PSSs panel and the Assigned PSSs panel, as required.

- 11 Click on the Apply button to deploy the 1830 PSS performance management policy to the assigned PSS.
 - 12 Click on the Cancel button to close the Assign form.
 - 13 Click on the OK button to close the 1830 PSS Performance Management Policy (Edit) form.
 - 14 Close the Optical Performance Management Policies form.
-

Procedure 8-13 To configure retention time for file-based statistics

- 1 Choose Equipment from the navigation tree view selector. The navigation tree displays the Equipment view.
- 2 Choose Network→1830 PSS→Shelf→Card Slot→Port.



Note — Choose the PM-supported ports.

- 3 Right-click on the Port and choose Properties from the contextual menu. The Physical Port [Edit] form opens with the General tab displayed.
 - 4 Click on the Statistics tab. The Administrative State and Retention Time columns are displayed.
 - 5 Choose an object type from the Select Object Type drop-down menu.
 - 6 Click on the Statistics Policies button and choose the Statistics Policy from the drop-down list. The Statistics Policy form appears with the name of the selected Object Type. Configure the parameters:
 - Retention Time (hours)
 - Administrative State
 - 7 Click on the Purge Statistics Records to purge all statistics records.

If these buttons are not visible, click on the More Actions button and choose the corresponding option from the drop-down menu.
 - 8 Click on the OK button. A dialog box appears. Click on the Yes button to proceed, the Statistics Policy form closes.
 - 9 Click on the OK button. The Physical Port [Edit] form closes.
-

Procedure 8-14 To clear the 1830 PSS bins

- 1 Choose Equipment from the navigation tree view selector. The navigation tree displays the Equipment view.
 - 2 Perform one of the following actions:
 - a For an EC card, choose Network→1830 PSS→Shelf→Card
 - b For other cards, choose Network→1830 PSS→Shelf→Port
 - 3 Right-click on the card slot or port and choose Properties from the contextual menu.
 - 4 The Card Slot/Physical port form opens. Click on the Card Specifics tab for the card and port Specifics tab for the port. Click on the Performance tab.
 - 5 Choose a profile type, select a profile, and click on the Properties button. The TCA Profile Assignment form opens with the General tab displayed.
 - 6 Configure the number of bins for each interval and choose from the drop-down, the option to clear bins. You can also assign a profile ID for each interval. See Procedure 8-16 to assign a profile ID.
 - 7 Click on the OK button. The TCA Profile Assignment form closes.
 - 8 Click on the OK button. The Card Slot/Physical port form closes.
-

8.14 PM profile types supported for line ports on amplifier cards

Inter-device management and control information is communicated over the Amplifier. The Amplifier card line ports support their own statistics profiles. The Amplifier is a separate optical channel that operates at the STM-1/OC-3 rate of 155 Mb/s. The Amplifier transfers management and control information between the ECs of two adjacent NEs, regardless of whether any of the DWDM payload channels are terminated between the two NEs. The channel transports IP and OSI PDUs. See the *Alcatel-Lucent 1830 Photonic Service Switch Product Information and Planning Guide* for more information.

8.15 Procedures for TCA profiles

The 5620 SAM supports all TCAs that are provided by the NE. The support includes configuring thresholds, distributing TCA profiles, and reporting on crossings (for example, raising and clearing of appropriate alarms). See the *Alcatel-Lucent 1830 Photonic Service Switch User Provisioning Guide* for more information about TCA support on the 1830 PSS.

TCA profiles

You can configure and assign a profile to an interval to monitor the value of each parameter in the active bin and raise a log event if a specific threshold level is reached. If a specified threshold is crossed, an alarm is raised.

You can configure each PM group with up to eight profiles, each profile can have different threshold levels. The 5620 SAM allows you to modify the TCA profiles. The threshold levels that you configure depend on the following factors:

- the interval length — for example, to gather statistics for an interface over 15m and 24h intervals you need to define two profiles: one that defines for the 15m interval and another for the 24h interval
- the service level of the traffic using the interface

Procedure 8-15 To configure thresholds for TCA profiles

- 1 Choose Equipment from the navigation tree view selector. The navigation tree displays the Equipment view.
- 2 Choose Tools→1830 PSS TCA Profiles to open a list of TCA profiles. The 1830 PSS TCA Profiles form opens.



Note 1 — These profiles are always on the 1830 PSS and cannot be deleted. Each profile contains a set of counters and parameters for which threshold values can be configured.

Note 2 — The global policy should be released for all discovered 1830 PSS NEs. To modify only a specific NE, modify only local definitions.

- 3 Choose a profile type and a profile ID from 1 to 8 and click on the Properties button. The NE TCA Profiles [Edit] form opens.
- 4 Click on the TCA Thresholds tab to display a list of TCA variable names with their threshold values.
- 5 Choose a TCA variable name and click on the Properties button. The NE TCA Thresholds [Edit] form opens.
- 6 Enter a threshold value and click on the OK button. The NE TCA Profiles [Edit] form is displayed.
- 7 Click the OK button. A dialog box is displayed.
- 8 Click on the Yes button to accept the changes.



Note — By default, profile ID 7 contains threshold values that can be applied to the 15m interval, and profile ID 8 contains threshold values that can be applied to the 24h interval.

Procedure 8-16 To assign TCA profiles to an EC card or port

After the profiles are assigned to an EC card or a port, see Procedure 8-15 for more information.



Note 1 – Only EC cards can be assigned to a PM TCA profile.

Note 2 – You can assign unique profiles for 15m intervals and 24h intervals for each EC card and port.

- 1 Choose Equipment from the navigation tree view selector. The navigation tree displays the Equipment view.
 - 2 Choose Network→NE→Shelf→Card or Port (EC: Equipment Controller Card).
 - 3 Right-click on the card slot or port and choose Properties from the menu. The Card slot/Physical port form opens.
 - 4 Click on the Card Specifics/Port Specifics tab and then click on the Performance tab.
 - 5 Click on the Profile Type, choose a profile, and click on the Properties button. The TCA Profile Assignment form opens.
 - 6 Configure the parameters as required.
 - 7 Click on the OK button. The TCA Profile Assignment form closes.
 - 8 Click on the OK button. The Card Slot/Physical port form closes.
-

Configuring PM

The prerequisites to configure PM are:

- Determine the interfaces and cards that you need to configure to collect PM data.
- Configure the profiles to specify the threshold levels at which log events are generated for the PM groups to be monitored on the NE.
- Configure each of the interfaces and cards on the NE for which you need to collect PM statistics. Configure the PM statistics to collect, the interval period over which they are collected, and the profile used for each interval period.

Viewing PM data

PM data is recorded in logs or bins. Logs record all of the TCAs that occur on the NE. The bins store data collected on a specific card or interface over a specific interval. In addition a raw bin for each PM group collects data until the data is cleared.



Note – When PM data is not available, PM parameter names are displayed with blank values.

Cards and ports that support PM data

Table 8-3 lists the transmission cards and ports that support PM data.



Note – The 11STMM10 hardware does not support GbE PM statistics in the egress direction. TX side of the PM data is not displayed for the 4DPA2 client or line ports.

Table 8-3 Transmission cards and ports

Cards	Ports
112SA1L 112SCA1	L1, C1
112SCX10 112SX10L	L1, C {1 to 10}
112SNA1	L1, C1
112SNX10	L1, C {1 to 10}
11DPE12 11DPE12A 11DPE12E	L {1, 2}, VA {1, 2}, C {1 to 12}
11DPM12	L {1, 2}, VA {1, 2}, C {1 to 12}
11QPA4	L {1 to 4}, VA {1 to 4}, C {1 to 4}
11QPE24	X {1 to 4}, C {1 to 11, 24}, VA {1 to 4}
11QPEN4	L {1 to 4}, C {1 to 4}, VA {1 to 4}
11STAR1	L1, C1
11STAR1A	L1, C1
11STGE12	L1, C {1 to 10}
11STMM10	L1, C {1 to 10}
43STA1P	L1, C1
43STX4 43STX4P	L1, C {1 to 4}
43SCA1	L1, C1
43SCX4 43SCX4E 43SCX4L	L1, C {1 to 4}
4DPA2	L {1, 2}, C {1, 2}
4DPA4 (Card Mode = FlexMux)	L {1, 2}, C {1 to 4}, VA {1, 2}
4DPA4 (Card Mode = DualTran)	L {1, 2}, C {1, 3}, VA {1, 2}
PSS1GBE	L {1, 2}, C {1 to 12}
PSS1MD4 (Card Mode = FlexMux)	L {1, 2}, C {1 to 4}

(1 of 2)

Cards	Ports
PSS1MD4 (Card Mode = DualTran)	L {1, 2}, C {1, 3}
PSS1P21	L1, C {1 to 21}
A2325A ALPHG AHPHG AHPLG AM2017B AM2325B	OSC, LINE, LINE- {9170-9605}
ALPFGT	OSCSFP, LINE, SIG, LINE- {9170-9605}
AM2318A and AM2125A	OSCSFP, LINEIN, LINEIN- {9170-9605}, LINEOUT, LINEOUT- {9170-9605}
AM2125B	OSCSFP, LINEIN, LINEOUT
EC	No port, PM data collected on the EC card and not on the port level
OSCT	OSCSFP, LINE, LINE- {9170-9605}
MVAC	G {1 to 8}
MVAC8B	L {1 to 8} C {1 to 9}
RA2P	LINEIN
SVAC	L1, C1
CWR8 CWR8-88	CLS {1 to 8}
43SCGE1	L1, C1
WR2-88	SIG, THRU, DROPOUT, ADDIN
WR8-88A WR8-88AF	MESHOUT{1 to 3}, ADDIN{1 to 8}, SIG, THRU, DROPOUT

(2 of 2)

Table 8-4 lists the dedicated cards that are required to boot the 1830 PSS.

Table 8-4 Dedicated cards and ports

Cards	Ports
FAN	No ports
USRPNL	OAMP, VOIP, E1, E2
EC	CIT (Local Ethernet Port), AUX, ES1, ES2
PFDC50 50A	No ports
PFDC60 60A	No ports

Displaying PM data for an EC card

You can display PM data only for an EC card.



Note — Card-level PM is not supported for other card types.

Procedure 8-17 To enable PM TCA alerts

- 1 Choose Equipment from the navigation tree view selector. The navigation tree displays the Equipment view.
- 2 Choose Network→NE
- 3 Right-click on NE and choose Properties from the menu.
- 4 The Network Element [Edit] form opens. Click on the NE Specifics tab. The General tab is displayed.
- 5 From the Performance Management panel, select the Enable PM TCA Alerts check box to enable the 5620 SAM to raise all TCA alerts.



Note — If the check box is disabled the 5620 SAM will not raise the TCA alerts.

- 6 Click the OK button. A dialog box is displayed.
 - 7 Click on the Yes button to accept the changes.
-

8.16 Procedures to configure LAGs

Use the following procedures to manage LAGs using the navigation tree.

Procedure 8-18 To create a LAG on an 11DPE12A card

- 1 Choose Equipment from the navigation tree view selector. The navigation tree displays the Equipment view.
- 2 Choose Network→NE→Shelf→Card Slot→LAGs.
- 3 Right-click on the LAGs icon and choose Create LAG from the contextual menu. The Create LAG step form with the Define General Properties step appears.

- 4 Configure the following parameters:
 - LAG ID
 - Auto Assign ID
 - Description
 - Administrative State
 - MTU (bytes)
- 5 Click on the Next button. The Configure LAG Parameters step appears.
- 6 Configure the parameters:
 - Size
 - SVLAN Tag Protocol ID
 - LOS Propagation
 - LPT Consequent Action
- 7 Click on the Next button. The Configure LACP step appears.
- 8 Configure the parameters:
 - Actor Administration Key
 - Actor System Priority



Note — LACP is always enabled.

- 9 Click on the Next button. The Configure LAG Members step appears.
- 10 Click on the Create button to add client ports to the LAG. The Create LAG Member step form with Only show compatible ports step appears.
- 11 Configure the parameters:
 - Show only Compatible Ports
 - Class
- 12 Click on the Next button. The Select Ports panel appears.
- 13 Select one or more compatible ports from the list and click on the Next button. The Specify the Member Properties step appears.
- 14 Configure the parameters:
 - Priority
 - Admin State
- 15 Click on the Finish button. A list of the selected ports appears in the Configure LAG members panel of the Create LAG step form.

The Specify Member Properties form closes and the Configure LAG Members form reappears. A dialog box appears.
- 16 Click on the OK button.

- 17 Click on the Finish button. The Configure LAG Members form closes and the Create LAG form reappears.
 - 18 Click on the Close button.
 - 19 Choose Network→NE→Shelf→Card Slot→LAGs→LAG. Right-click on the created LAG and choose Properties from the contextual menu to view information about the created LAG or to modify LAG parameters.
 - The General tab displays the LAG ID, description, and the configured MAC address.
 - The Link Aggregation Group tab displays the parameters selected during LAG creation, including Number of selected ports, Number of attached ports, size, SVLAN Protocol ID, LOS propagation, LPT Consequent action and Bandwidth Attributes.
 - The States tab displays the administrative state, which is the LAG enabled or disabled state on the node.
 - The LACP tab displays the LACP parameters such as LACP mode, Actor Administration Key, Actor Operational Key, Partner Operational Key, Actor System ID, Partner System ID, Actor System Priority and Partner System Priority.
 - The LAG Members tab allows you to add the LAG member ports.
 - The VTS map tab displays the VTS map parameters such as VTS Map Number, VTS Direction, Classification Mode, CE-VLAN ID, and SVLAN ID.
 - Statistics, terminations, and fault information is available from the appropriate tabs.
 - 20 Expand the LAG object in the navigation tree to display the created LAG.
 - 21 Expand the LAG object to display LAG members.
-

Procedure 8-19 To create a LAG on an 11QPE24 card

- 1 Choose Equipment from the navigation tree view selector. The navigation tree displays the Equipment view.
- 2 Choose Network→NE→Shelf→Card Slot→LAGs.
- 3 Right-click on the LAGs icon and choose Create LAG from the contextual menu. The Create LAG step form with the Define General Properties step appears.
- 4 Configure the following parameters:
 - LAG ID
 - Auto Assign ID
 - Description
 - Configured Address
 - L2Uplink
 - Mode
 - Encap Type
 - Administrative State
- 5 Click on the Next button. The Configure LACP step appears.

- 6 Configure the parameters:
 - LACP Transmit Interval
 - LACP Transmit Standby
 - Actor System ID
 - Partner System ID
 - Actor System Priority
 - Partner System Priority
 - Active Sub-Group selection Criteria
- 7 Click on the Next button. The Configure LAG Members step appears.
- 8 Click on the Create button to add client ports to the LAG. The Create LAG Member step form with the Only show compatible ports step appears.
- 9 Configure the parameters:
 - Show only Compatible Ports
 - Class
- 10 Click on the Next button. The Select Ports step appears.
- 11 Choose one or more compatible ports from the list and click on the Next button. The Specify the Member Properties step appears.
- 12 Configure the parameters:
 - Priority
 - Sub-Group ID
- 13 Click on the Finish button. A list of the selected ports appears in the Configure LAG members step of the Create LAG step form.

The Specify Member Properties form closes and the Configure LAG Members form reappears. A dialog box appears.
- 14 Click on the OK button.
- 15 Click on the Finish button. The Configure LAG Members form closes and the Create LAG form reappears.
- 16 Click on the Close button.

- 17 Choose Network→NE→Shelf→Card Slot→LAGs→LAG. Right-click on the created LAG and choose Properties from the contextual menu to view information about the created LAG or to modify LAG parameters.
 - The General tab displays the LAG ID, description, and the configured MAC address.
 - The Link Aggregation Group tab displays the parameters selected during LAG creation, Number of selected ports, Number of attached ports, and size.
 - The States tab displays the administrative state, which is the LAG enabled or disabled state on the node.
 - The LACP tab displays the LACP parameters, such as LACP mode, Actor Administration Key, Actor Operational Key, Partner Operational Key, Actor System ID, Partner System ID, Actor System Priority and Partner System Priority.
 - LAG Members tab allows you to add the LAG member ports.
 - Statistics, terminations, and fault information is available from the appropriate tabs.
 - 18 Expand the LAG object in the navigation tree to view the created LAG.
 - 19 Expand the LAG object to view LAG members.
-

9 — 1830 PSS equipment navigation tree

9.1 Equipment navigation tree overview 9-2

9.1 Equipment navigation tree overview

The view selector in the 5620 SAM navigation tree is a drop-down menu that lists the physical and logical network views that are available. You can use the contextual menu for an object in the navigation tree to create, configure, and manage specific parameters for the object and child objects.

Using the 1830 PSS external element manager

You can start the 1830 PSS external element manager, Zero Install Craft (ZIC) interface, from the 5620 SAM GUI. The ZIC interface provides a web-based user interface (WebUI) to access the NE. The WebUI supports provisioning, administration, performance monitoring, and displaying alarms and conditions from the NE. For more information about using the WebUI with the 1830 PSS, see the *Alcatel-Lucent 1830 Photonic Service Switch 36/32/16 (PSS-36/PSS-32/PSS-16) User Provisioning Guide*. Procedure 9-1 describes how to start the 1830 PSS external element manager from the 5620 SAM GUI.

Procedure 9-1 To launch the 1830 PSS external EMS browser

- 1 Choose Equipment from the view selector in the navigation tree. The navigation tree displays the Equipment view.
- 2 Right-click on a discovered 1830 PSS device in the Equipment view and choose Launch External EMS Browser from the contextual menu. The ZIC main view screen appears.



Note 1 – The 1830 PSS external EMS browser is supported on Internet Explorer 6.0 or later or FireFox 3.6.

Note 2 – If the 1830 PSS device is in encrypted mode, you cannot launch a web session.

Note 3 – If the 1830 PSS device is in secure mode, the Launch External EMS Browser is disabled.

1830 PSS network management

10 – 1830 PSS routing and forwarding

11 – 1830 PSS service tunnels

10 – 1830 PSS routing and forwarding

10.1 Routing and forwarding overview 10-2

10.2 Workflow to configure protocols 10-2

10.3 Routing and forwarding procedures 10-3

10.1 Routing and forwarding overview

You can view, create, modify and delete the routing and forwarding parameters on the 1830 PSS device. You can use the Routing view in the 5620 SAM GUI navigation tree to manage these functions. See the chapter, “NE routing and forwarding” in the *5620 SAM User Guide* for more information.

The following protocols are supported on the 1830 PSS devices:

- OSPFv2
- IGMP

OSPFv2

OSPFv2 is a hierarchical link-state interior gateway protocol that operates within ASs and is used in IP networks. OSPF packets are routed based on the destination IP address of the IP packets. The 1830 PSS devices, 1830 PSS-32 and 1830 PSS-16 support multi-area OSPFv2 to improve DCN set-up and scalability. You can create, modify or delete a multi-area OSPFv2. The 1830 PSS devices will support creating and deleting system-level OSPF areas. See the section, “OSPF configuration procedures” in the *5620 SAM User Guide* for information about how to configure OSPF.

IGMPv2

IGMP is a multicast protocol which service providers can use to establish multicast group memberships on a LAN. Within the LAN, end users use IGMP to communicate with a local multicast router, which then uses PIM to distribute the IGMP messages to other local and remote multicast routers. Multicast routers send regular membership queries to IGMP hosts which respond with membership reports. Multicast routers can use these reports to determine which hosts are interested in receiving particular multicast messages. IGMP operates above the network layer on IPv4 networks. See the section, “IGMP configuration procedures” in the *5620 SAM User Guide* for more information about how to configure IGMP.

10.2 Workflow to configure protocols

Prerequisites:

- You know the 32-bit unique router ID prior to configuring OSPF.

Use the 5620 SAM navigation tree to create, modify and delete an OSPF.

- 1 To create an OSPF, see Procedure [10-1](#) for more information.
- 2 To modify an OSPF, see Procedure [10-2](#) for more information.
- 3 To delete an existing OSPF, see Procedure [10-3](#) for more information.

10.3 Routing and forwarding procedures

The following procedures describe how to create, modify and delete a multi-area OSPF. See the *5620 SAM Optical Parameter Reference* for more information on parameter descriptions.



Note — Multi-area OSPF is supported only on nodes 1830 PSS-32, and 1830 PSS-16 from Release 3.6.5 or later.

Procedure 10-1 To create a Multi-area OSPFv2

- 1 In the 5620 SAM navigation tree, choose Routing from the view selector.
- 2 Choose Network→1830 PSS NE→Routing Instance→OSPFv2.
- 3 Right-click on OSPFv2 and choose Create Area. The Area Site [Create] form opens. The NE has a default area.
- 4 Configure the parameters in the Routing Instance panel:
 - Area ID
 - Type
 - Normal
Configure Virtual Link IP
 - NSSA
Configure NSSA Router Translation
Configure ABR Default Route Cost
 - NSSA Totally Stub
Configure NSSA Router Translation
Configure ABR Default Route Cost
 - Stub
Configure ABR Default Route Cost
 - Totally Stub
Configure ABR Default Route Cost
 - Area Index
 - DNS Opaque LSAs Distributed
 - Wavekey Opaque LSAs Distributed



Note — The DNS Opaque LSAs Distributed and Wavekey Opaque LSAs Distributed parameters can be enabled for only one of the OSPF areas on the 1830 PSS. By default, the backbone area ID (0.0.0.0) will have these options enabled and it cannot be enabled for the other types. This will result in an error message. If you set the parameter to No on the backbone area ID, you will be allowed to enable these parameters for other area IDs created. You can create up to three OSPF areas, in addition to the default backbone area (0-0-0-0).

- 5 Click on the Apply button. The area site is created.

- 6 Click on the OK button. The Area Site [Create] form closes, and a dialog box appears.
 - 7 Click on the Yes button to confirm the action.
-

Procedure 10-2 To modify a Multi-area OSPFv2

- 1 In the 5620 SAM navigation tree, choose Routing from the view selector.
- 2 Choose Network→1830 PSS NE→Routing Instance→OSPFv2.
- 3 Select the area to be modified on the NE. Right-click on Area and select Properties, the Area Site [Edit] form opens.
- 4 Modify the parameters in the Routing Instance panel:
 - Type
 - DNS Opaque LSAs Distributed
 - Wavekey Opaque LSAs Distributed



Note — If you modify the Type, update the appropriate options that are displayed based on the selected type. See Procedure 10-1 for more information.

- 5 Click on the Apply button. The area site is modified.
 - 6 Click on the OK button. The Area Site [Edit] form closes, and a dialog box appears.
 - 7 Click on the Yes button to confirm the action.
-

Procedure 10-3 To delete a Multi-area OSPFv2

- 1 In the 5620 SAM navigation tree, choose Routing from the view selector.
 - 2 Choose Network→1830 PSS NE→Routing Instance→OSPFv2→Area.
 - 3 Right-click on the selected area and choose Delete. A Confirm dialog box is displayed.
 - 4 Click on the Yes button to confirm the action. The selected area is deleted.
-

11 – 1830 PSS service tunnels

11.1 Service tunnel overview 11-2

11.2 Ethernet (G.8032) ring protection 11-2

11.1 Service tunnel overview

A service tunnel is an entity used to unidirectionally direct traffic from one device to another device. The service tunnel is provisioned to use a specific encapsulation method, such as GRE or MPLS, and the services are then mapped to the service tunnel.

On the Optical Transport Service (Edit) form, the Service Tunnels tab lists all objects considered as service tunnels (SDPs, Ethernet rings, Ethernet tunnels, other services, and so forth) that are currently used by the service you are querying. The associated Discover Service Tunnels button removes any previously discovered service tunnels on the service and triggers a manual re-discovery of these, based on direct usage and current service configurations.



Note – 11QPE24 cards support ERP. ODU trails are added as tunnels for ERP. To create ODU trails between the cards, see Procedure [12-19](#).

The Flow-through Services tab lists all other services that are currently using the object you are querying as a service tunnel. The associated Discover Flow-through Services button removes any previously discovered flow-through services and triggers a manual re-discovery of these, based on direct usage and current service configurations.

You can manage service tunnels on the 1830 PSS device. See the section, “Configuring service tunnel procedures” in the *5620 SAM User Guide* for more information about how to configure and manage service tunnels.

11.2 Ethernet (G.8032) ring protection

The 5620 SAM supports Ethernet ring protection on the Ethernet Optical transport services on the 11QPE24 card for the 1830 PSS-32, 1830 PSS-16 and 1830 PSS-4 devices. ERP is used for network protection of Ethernet services. See the section, “Ethernet (G.8032) rings” in the *5620 SAM User Guide* for more information.

ERP

ERP switching offers ITU-T G.8032 specification compliance to achieve resiliency for carrier ethernet networks. Like STP networks, ERP keeps one link in the ring blocked to user traffic, but also like MSTP, it is possible to run multiple ring sessions on the same physical ring, with different blocked links in each. This enables load balancing on the ring when traffic patterns allow.

Stand-alone rings are supported, only on uplink (NNI) ports, but multiple non-interworking ring instances are supported.

VPLS services can use ERP (Epipes behaves as two-node ERPs). All VPLS services may be protected by one ethernet ring instance, or divided among several rings.

ERP is represented on uplink (NNI) ports. ERP switching is triggered by NNI port failures, and optionally by Ethernet OAM CCM link faults detected by Down MEPs on the ring ports, for a ring topology in which links are not directly connected. Although ring switching can be held off to allow underlying protection to operate first, the advantage of ERP is its (~50 ms) protection switching.

Ethernet rings use the G.8032 standard protocol for control, and participating nodes exchange protocol messages using Y.1731 defined OAM frames called R-APS. R-APS frames are sent by MEPs belonging to an MA not associated with a service, and positioned on ring paths. R-APS frames are tagged and should be configured with a unique (not shared with a service or other rings) VID when the ring port has dot1q encapsulation, and with a unique outer VID when the ring port has QinQ encapsulation. Ethernet rings are only on individual NNI ports which use QinQ encapsulation.

Service provisioning on Ethernet (G.8032) rings

The 5620 SAM accelerates the provisioning of VPLS instances on Ethernet (G.8032) rings by automatically creating the Control and Data services on the rings. Services are configured on Ethernet (G.8032) rings in the same method as service tunnels. You can create Ethernet (G.8032) rings using the 5620 SAM GUI. See the procedure, “To create an Ethernet (G.8032) ring” in the *5620 SAM User Guide* for more information about how to create an Ethernet ring, its associate control service, data service, and assign ring elements to the ring.

1830 PSS optical transport service management

12 — 1830 PSS optical transport service management

12 – 1830 PSS optical transport service management

- 12.1 Optical transport services overview 12-2
- 12.2 Y-cable protection 12-3
- 12.3 Dual stage multiplexing 12-4
- 12.4 Regeneration services on the 1830 PSS 12-4
- 12.5 Ethernet service management 12-7
- 12.6 Workflow to configure optical transport services 12-8
- 12.7 Procedures to configure optical transport services 12-8
- 12.8 Managing optical power levels using the Wavelength Tracker 12-28
- 12.9 Procedures to manage optical power levels 12-36
- 12.10 OTN Trails 12-41

12.1 Optical transport services overview

An optical transport service is a wavelength that traverses the network between two endpoints, which can be tandem wavelengths in some cases. The path the service takes through the network is defined by 5620 SAM using shortest path algorithm and the knowledge of the NE adjacencies.

An XC is the path that the service takes through an NE. A cross-connect is defined by the ingress and egress points for the service on the NE.

The NE physical topology defines the internal path that the service takes through the NE.

The 5620 SAM supports the following:

- identification of adjoining XCs and management of linked XCs as an optical transport service
- creation, deletion, and discovery of optical transport services, where there are no XCs
- discovery of optical transport service between OTs of the vendor network

Each service is assigned a trail identifier and a pair of Wavelength Tracker wave keys. The trail identifier, the ITU channel number (wavelength) and wave key pair are unique in the network. See Tables 12-4, 12-5, and 12-6 for more information.

Optical transport services create transport connectivity between router ports and hence they must be created before any IP services.

Services are created by selecting the endpoints, the 5620 SAM is then applied to complete the service creation.

The 5620 SAM supports optical transport services between:

- two 1830 PSS NEs
- two non-PSS NEs, that is, 7750 SR, 7450 ESS, 7705 SAR, 7210 SAS E,M,X,D, and 7950 XRS.
- an 1830 PSS NE and a non-1830 PSS NE, that is, 7750 SR, 7450 ESS, 7705 SAR, 7210 SAS E, M, X, D, and 7950 XRS.

Protection schemes:

- provisioning of diverse route service
- provisioning and discovery of OPS and Y-cable, and Regen protected services
- discovery of E-SNCP protected service, and Regen services

For OPS service provisioning, you can only specify the following ports as termination points:

- 11STAR1 client port
- 11STAR1A client port
- 11STGE12 client port
- 11STMM10 client port
- 11QPA4 client port
- 11QPEN4 client port
- OPSA SIG
- 112SNX10 client port
- 112SNA1 client port
- 112SCA1 client port
- 112SCX10 client port



Note – The E-SNCP and Y-cable should not coexist on the 11QPEN4 card. For example, if there is at least one E-SNCP protection group created on a board, the Y-cable protection should not be on the board and vice versa.

12.2 Y-cable protection

Y-cable protection is a network side protection mechanism that protects line card, client side laser, network side laser, and network side fibers. Y-cable protection is based on a pair of OT cards at the near-end and far-end of the network. Y-cable protection can be used with any supported type of OT, but the near-end working OT must be connected to the far-end working OT and the near-end protection OT must be connected to the far-end protection OT. The working and protection ports must be provisioned for the same signal rate and format and must be configured with the same threshold values, at both ends of the network.



Note 1 – The working and protection OTs must be the same type. The 5620 SAM does not allow service creation when card types are different.

Note 2 – The near-end and far-end OTs must be the same type. The 5620 SAM allows service creation when card types are different.

Y-cable support on working and protection OTs

43SCX4E card

The 43SCX4E is a double width variant, full height card that is supported on the 1830 PSS-32 device. This card is similar in all its functionalities to the 43SCX4 card.

11QPEN4 card

Y-cable protection is supported on the 11QPEN4 OT card. The working and protection OTs must be the same type at the near and far end. For example, there should be an 11QPEN4 card at each end, and near-end port C1 must be connected to the far-end port C1, port C2 to port C2. Unidirectional Y-cable is supported with CBR client mapping, but is not supported with GFP-F client mapping. On the 11QPEN4 card, up to two protection groups can be created. A protection group consists of two line ports and one client port. Each protection group operates independently of the other, with its own protection state.

The 11QPEN4 and the 11QPA4 cards, are channels in the Y-cable protection group and are independent channels on working and protection boards. The channel numbering at one end may not be the same as the channel numbering at the other end. For example, channel C1 and L1 in the near-end working and protection pairs can connect to channel L2 and C2 at the far-end working. The protection pairs form an end-to-end protected service.

A 11QPEN4 OTU2 client port (OT A) can be connected to 11DPE12 and 11DPE12E line ports (OT B). Up to four 11DPE12 and 11DPE12E OTs can be connected to one 11QPEN4. This configuration is encrypted for GbE services.

A 11QPEN4 OTU2 client port (OT A) can be connected to a 11DPM12 line port (OT B). Up to four 11DPM12 OTs can be connected to one 11QPEN4. This configuration is encrypted for GbE, FC100, FC200 and FC400 services.



Note 1 – The operational mode on the 11QPEN4 line port is Add/Drop only.

Note 2 – The client ports on the 11QPEN4 cannot be assigned to the OC192/STM64 rate.

12.3 Dual stage multiplexing

Dual stage multiplexing is supported on the 1830 PSS-16 and 1830 PSS-32 shelves. A signal is added to an OT client port and multiplexed on a line port with a larger bandwidth. The signal is added a second time at a higher rate OT and multiplexed to the line port. The reverse path is followed if the signal is dropped. See Procedure 12-5 and the *Alcatel-Lucent 1830 Photonic Service Switch User Provisioning Guide* for more information.

12.4 Regeneration services on the 1830 PSS

The 1830 PSS supports provisioning, discovery and a topological view of the following regeneration services. To provision these services, see Procedure 12-1. To discover these services, see Procedure 12-11. To view these services in the topological view, see the *5620 SAM User Guide*.



Note – The Regen check box is automatically checked when a regen service is created. You can view this on the General tab on the Service Path form.

- DWDM–DWDM
- DWDM–CWDM
- CWDM–Black & White
- DWDM–Black & White

DWDM-DWDM

DWDM–DWDM single channel OEO regeneration is supported with back-to-back OTs connected through the client ports. Keyed and unkeyed services are supported on this configuration. The following OTs are supported:

- 11STAR1
- 11STAR1A
- 43STA1P
- 43STX4
- 43STX4P



Note – For regeneration on the 43STA1P, the client port rate must be OC768 or STM256. Do not use OTU3.

DWDM–DWDM single channel OEO regeneration is supported with two single port OTs that have line port operational modes configured for regeneration. Client ports are not used in this configuration. The following OTs are supported:

- 112SA1L (drop shelf only)
- 112SCA1
- 112SNA1
- 112SCX10
- 112SNX10
- 43SCGE1
- 112SX10L (drop shelf only)
- 43SCA1
- 43SCX4
- 43SCX4E
- 43SCX4L (drop shelf only)



Note – For this configuration, the channels can be different on each SFD or CWR port.

DWDM-CWDM

The 1830 PSS-32 supports single channel regeneration for CWDM and DWDM connections and configurations for CWDM bidirectional transmission with DWDM-CWDM (dual-fiber) regeneration, where regeneration OTs are supported. The Rate supported for this service is FC200. Keyed and unkeyed services are supported on this configuration. The following OTs are supported:

- 11STAR1 and 11STAR1A OT—line port is connected to the DWDM signal and the client port is connected to the CWDM signal
- 4DPA4 OT (FlexMux only)—one line and an eVOA port is connected to the DWDM signal and the other line and eVOA port is connected to the CWDM signal. The line ports are configured for CrossRegen mode

- 11QPA4 OT—a line and an eVOA port is connected to the DWDM signal and the associated client port is connected to the CWDM signal



Note — 11QPEN4 supports regeneration services with the 11QPA4 as the A end and Z end of the service.

CWDM-Black & White

CWDM-Black & White single channel OEO regeneration is supported during the working of the 1830 PSS-32 and 1830 PSS-1 GBEH devices. The rate supported for this service is 1Gbe. Unkeyed service is supported on this configuration and no cross connects are created. The following OTs are supported:

- 4DPA4 OT (FlexMux only)—one line and an eVOA port is connected to the CWDM signal and the other line port is connected to the Black & White signal. The line ports are configured for CrossRegen mode
- 11QPA4 OT—a line port is connected to the CWDM signal and the associated client port is connected to the Black & White signal



Note — 11QPEN4 supports regeneration services with the 11QPA4 as the A end and Z end of the service.

CWDM-FOADM

Degree-2 CWDM-FOADM is supported on the 1830 PSS. Any symmetrical combination of OMD-based end terminal configuration is supported.

The following configurations are supported:

- SFC-2—SFC-2
- SFC-4—SFC-4
- SFC-8—SFC-8

The following OTs are supported:

- 4DPA4
- 11DPE12

DWDM-Black & White

DWDM-Black & White single channel OEO regeneration is supported during the working of the 1830 PSS-32, and 1830 PSS-1 GBEH devices. The Rate supported for this service is 1Gbe. The following OTs are supported:

- 11STAR1 and 11STAR1A OT—the line port is connected to the DWDM signal and the client port is connected to the Black & White signal. Regeneration takes place from client to line.
- 4DPA4 OT (FlexMux only)—one line and an eVOA port is connected to the DWDM signal and the other line port is connected to the Black and White signal. The line ports are configured for CrossRegen mode

- 11QPA4 OT—a line and an eVOA port is connected to the DWDM signal and the associated client port is connected to the Black & White signal



Note – 11QPEN4 supports regeneration services with the 11QPA4 as the A end and Z end of the service.

12.5 Ethernet service management

VPLS management on the 1830 PSS

VPLS is a class of virtual private network multipoint L2 service that allows multiple customer sites to be connected in a single bridged domain contained within the service provider-managed IP/MPLS network. Customer sites in the VPLS appear to be on the same LAN, even if the sites are geographically dispersed. You can create, and delete a VPLS service on the 11QPE24 card. You can also modify a service from the topology view. See the *5620 SAM User Guide* and the *5620 SAM Parameter Guide* for more information.



Note 1 – On the 11QPE24 card, VPLS services are configured at the card level and not at the NE level.

Note 2 – A VLAN ID is only applicable when the SAP type is equal to dot1q-preserve.

Note 3 – A VPLS service cannot be deleted if there are SAPs defined for the service.

Note 4 – A VPLS must have the Admin State set to Down to be deleted from the service.

Mirroring

In a mirror service, packets from one or more sources are forwarded to their configured destinations. A copy of the entire packet, or a specified portion of the packet, is sent to the mirror destination. The mirrored packet can be viewed using a packet-decoding device, typically called a sniffer, that is attached to the destination port. The 5620 SAM does not limit the number of destination and source sites that can be added under a mirror service. The mirrored packets are transported unidirectionally through the core network using IP or MPLS tunneling. For more information about mirror services, see *5620 SAM User Guide*.

12.6 Workflow to configure optical transport services

This workflow is used to configure optical transport services:

- 1 The EPT, and CPB tools are non-5620 SAM tools which must be first used for transport network power balancing and commissioning tasks. See the *Alcatel-Lucent 1830 Photonic Service Switch (PSS) Engineering and Planning Tool User Guide* and the *Alcatel-Lucent 1830 Photonic Service Switch (PSS) Commissioning and Power Balancing Tool User Guide* for more information.
- 2 Use the 5620 SAM GUI to:
 - Create optical links that represent the external 1830 PSS/ 7750 SR adjacencies and the internal topological links within the 1830 PSS NEs. See Procedure [8-8](#) for more information.
 - Create an optical transport service. See Procedure [12-1](#).
 - Discover the optical transport services. See Procedure [12-11](#).
 - Unmanage an optical transport service. See Procedure [12-12](#).
 - Create a multipoint transport service. See Procedure [12-2](#).
 - Create and delete a drop site on an unprotected multipoint service in a 11DPM12 card. See Procedures [12-3](#) and [12-4](#).
 - Create dual stage multiplexing service on the 1830 PSS for keyed and unkeyed services. See Procedure [12-5](#).
 - Create single fiber bidirectional support on the 1830 PSS for unkeyed services. See Procedure [12-6](#).
 - Create, configure and delete ODU trails. See Procedures [12-19](#), [12-20](#) and [12-21](#).
 - View the optical channel usage. See Procedure [12-22](#).
 - Create and delete ODUK XCs on 11DPM12 cards. See Procedures [12-23](#) and [12-24](#).

12.7 Procedures to configure optical transport services

Procedure 12-1 To create an optical transport service using configuration forms

- 1 Choose Create→Service→Optical→Create Transport Service from the 5620 SAM main menu. The Optical Transport Service Subscriber [Create] form opens.
- 2 Click on the Select button to choose a customer to associate with the optical transport service. The Select Customer - Optical Transport Service form opens.

- 3 Choose a customer for the optical transport service and click on the OK button. The Select Customer - Optical Transport Service form closes and the Optical Transport Service [Create] form reappears with the customer information displayed on the General tab.



Note — You can create a template for the service at every stage by using the Apply or OK button before you specify the optical sites and termination points. You can use the service template to create a service by adding optical sites and termination points. See steps 12 to 18 to create an optical site.

- 4 Configure the parameters:
 - Service Name
 - Description
 - Service ID
 - Auto-Assign ID
 - Direction
 - Bidirectional—creates bidirectional cross-connects and displays hops from A to Z and Z to A after service creation
 - Unidirectional—creates unidirectional cross-connects and displays hops from A to Z after service creation
 - Service Priority
 - Wavekey Assign Mode
 - Auto Keying (NE)
 - Auto Keying (NMS)
 - Unkeyed
 - States
 - Administrative State
 - Operational State
- 5 Configure the Rate parameter, or a SubRate service or a QinQ service, by setting the Rate parameter to SubGigE and configure the parameters on the VLAN Configuration Details panel, if required. See table 12-1 for more details.

Table 12-1 Rate parameter value

Rate	Service
SubGigE	SubRate: <ul style="list-style-type: none"> • CE-VLANID • Committed Info Rate (Mbps) • Excess Info Rate (Mbps) • Committed Burst Size (Kbytes) • Excess Burst Size (Kbytes)

(1 of 2)

Rate	Service
SubGigE	QinQ—Perform steps 15-24 . <ul style="list-style-type: none"> • Is SubGigeService QinQ • Is SVLAN Push-Pop/Keep Capable QinQ Service • QinQ Service Stack-VLAN Tagging Configuration <ul style="list-style-type: none"> • Push-Pop • Keep • A-Ingress-Z-Egress CE-VLANID ⁽¹⁾ • Z-Ingress-A-Egress CE-VLANID ⁽¹⁾ • A-Egress-Z-Ingress Stack-VLANID ⁽²⁾ • A-Ingress-Z-Egress Stack-VLANID ⁽²⁾ • Committed Info Rate (Mbps) • Excess Info Rate (Mbps) • Committed Burst Size (Kbytes) • Excess Burst Size (Kbytes)
SubGigE	Full Rate: <ul style="list-style-type: none"> • Is SubGigeService QinQ • Is SubGige Full Rate Service • A-Egress-Z-Ingress Stack-VLANID • A-Ingress-Z-Egress Stack-VLANID

(2 of 2)

Notes

- (1) For line SVID configuration with a QinQ Service Stack-VLAN Tagging Configuration of Push-Pop, the value of A-Ingress-Z-Egress CE-VLANID and Z-Ingress-A-Egress CE-VLANID must be the same.
- (2) For line SVID configuration, the value of A-Egress-Z-Ingress Stack-VLANID and A-Ingress-Z-Egress Stack-VLANID must be the same.

See the *5620 SAM Optical Parameter Reference* guide for specific rates applicable for various cards.

6 Configure the Protection Type parameter. See Table [12-2](#) for more information:

- Unprotected
- Diverse Route
- ESNCP Protected
- OPS Protected
- Y-Cable Protected

Table 12-2 Protection Type parameter options

Option	Description	
Diverse Route	<p>Diverse Route Details panel: ⁽¹⁾ ⁽²⁾ ⁽³⁾</p> <ul style="list-style-type: none"> • Select the Use Existing Unprotected Services check box and choose up to two existing unprotected services. • Choose a Service Name for the Working Path Service • Choose a Service Name for the Protection Path Service <p>A Diverse Route service is created and the existing unprotected services are deleted.</p>	
ESNCP Protected	ESNCP service supports the following cards and configurations:	
	<table border="0"> <tr> <td> <ul style="list-style-type: none"> • 4DPA2 • 4DPA4 • 11QPA4 • 11QPEN4 • 11DPM12 • 11DPE12 </td> <td> <ul style="list-style-type: none"> • 11DPE12A • 11DPE12E • 1830 PSS-1 GBE • 1830 PSS-1 MD4H </td> </tr> </table>	<ul style="list-style-type: none"> • 4DPA2 • 4DPA4 • 11QPA4 • 11QPEN4 • 11DPM12 • 11DPE12
<ul style="list-style-type: none"> • 4DPA2 • 4DPA4 • 11QPA4 • 11QPEN4 • 11DPM12 • 11DPE12 	<ul style="list-style-type: none"> • 11DPE12A • 11DPE12E • 1830 PSS-1 GBE • 1830 PSS-1 MD4H 	
OPS Protected	OPS service supports the following cards:	
	<table border="0"> <tr> <td> <ul style="list-style-type: none"> • 11STAR1 • 11STAR1A • 11STGE12 • 11STMM10 • 11QPA4 • 11QPEN4 </td> <td> <ul style="list-style-type: none"> • OPSA • 112SNX10 • 112SNA1 • 112SCA1 • 112SCX10 </td> </tr> </table>	<ul style="list-style-type: none"> • 11STAR1 • 11STAR1A • 11STGE12 • 11STMM10 • 11QPA4 • 11QPEN4
<ul style="list-style-type: none"> • 11STAR1 • 11STAR1A • 11STGE12 • 11STMM10 • 11QPA4 • 11QPEN4 	<ul style="list-style-type: none"> • OPSA • 112SNX10 • 112SNA1 • 112SCA1 • 112SCX10 	
Y-Cable Protected	<p>Configure the parameters in the APS Group panel:</p> <ul style="list-style-type: none"> • Revert Mode • APS Direction • Wait to Restore (minutes) 	

Notes

- (1) You can also create a diverse route service by choosing two termination points on the A end site, and two termination points on the Z end site.
- (2) Diverse route services can only be created by using the 5620 SAM and the services are not part of the service discovery operation.
- (3) If you unmanage a diverse route and run the discover transport services operation, the 5620 SAM discovers two unprotected services instead of a diverse route service.

- 7 Click on the Path Constraints tab and choose Create. The Constraint [Create] form opens.

- 8 Configure the parameters:
 - Constraint Type
 - Inclusion
 - Exclusion
 - Constraint Element
 - Port
 - Site
 - Trail
 - Service Path Type
- 9 Click on the Select button. When you specify Port, Site or Trail as the Inclusion or Exclusion element, the Select Port Constraint form opens.
- 10 Choose the Ports, Sites or Trails to be included or excluded.
- 11 Click on the OK button. The Port Constraint or Site Constraint form closes.



Note 1 – You can include or exclude ODU trails in a service. See steps 7-11.

Note 2 – The selected constraint is applicable to unprotected, working or protection service paths.

- 12 Click on the Service Sites tab and choose Create Optical Site. The Select Network Elements - Optical Transport Service form opens with a list of available sites.
- 13 Choose a site. Press the CTRL key, and choose another site. Click on the OK button.
- 14 Right-click on the selected site and click on Properties, the Optical Site [Create] form opens with the General tab displayed.
- 15 Click on the Termination Point tab to configure the termination point for the NE.
- 16 Click on Create on the right panel. The Termination Point [Create] form opens.
- 17 Click on Select. The Select Port - Termination Point form opens.

- 18 Choose a port and click on the OK button. The Select Port - Termination Point form closes and the Termination Point [Create] form reappears.



Note 1 – In this form, only the termination points that can be configured with the specified service rates are displayed.

Note 2 – If a termination point is used in another service, the termination point is not displayed (except for SubGigE services).

Note 3 – If a termination point is configured with another valid rate, the termination point is not displayed.

Note 4 – Steps 19a, 20a to 23 apply to QinQ service only.

Note 5 – Steps 19b, 20b apply to CWDM, DWDM and Black & White services.

Prerequisites to configure an OPTSG client. To configure the OPTSG client, see option a. See Procedure 12-10 for more information about configuring timeslots.

- Provision timeslots on line ports, to create a line port ODUk facility object.
- Associate ODU1PTF object with the line port ODUk facility object to create the cross connect. The ODU1PTF can be associated only with the Odu1 container (with 2 timeslots) on a line port.
- Provision timeslots on ODU1PTF to create OPTSG objects.
- Provision the service with OPTSG clients.



Note 1 – Repeat points 1 to 3 of the prerequisites on the source and destination ports.

Note 2 – Automatic provisioning of timeslots on the line ports to create a line port ODUk facility object is supported on the 11DPM12 cards.

Note 3 – This is applicable to Keyed and Unkeyed services.

Note 4 – Line port ODUk Facility objects are created when timeslots are configured on line ports. See Procedure 12-10 for more information about configuring timeslots manually. When the service is provisioned, the ODUk cross connects are created between client and line Port ODUk facility objects.

- a If the selected client port is configured in OPTSG mode, the Optsg Termination Point panel opens. Click on Select. The Select Optsg - Termination Point form opens. Choose the appropriate OPTSG object and click on the OK button. The Select Optsg - Termination Point form closes and returns to the Termination Point [Create] form.



Note 1 – This termination point panel also appears if the selected client port is an SR end point and if it is connected to a 11DPM12 client port configured in OPTSG mode.

Note 2 – Option a applies only to 11DPM12 cards and to client ports configured in the OPTSG mode. The OPTSG mode is supported only for OC3/STM1 and OC12/STM4 client rates.

Note 3 – This is applicable for Keyed services.

19 Configure the parameters:

- a In the Client Port Virtual Time Slot (PSS Endpoint) panel:

- Client Port
- Ingress VTS Number
- Egress VTS Number

- b In the Optical Access Port Virtual Time Slot panel:

- Client VTS Number
- Ingress VTS Number
- Egress VTS Number

If the Flow Continuity Monitoring value for the OT Card is CCM, then the value of the Ingress VTS Number and Egress VTS Number parameters must be the same. See *Alcatel-Lucent 1830 Photonic Service Switch User Provisioning Guide* for more information.

20 Configure the parameters:**a** In the Line Port Virtual Time Slot (PSS Endpoint) panel:

- Line Port
- Line Port Number
- Line VTS Number
- Ingress VTS Number
- Egress VTS Number

If the Flow Continuity Monitoring value for the OT Card is CCM, then the value of the Ingress VTS Number and Egress VTS Number parameters must be the same. See the *Alcatel-Lucent 1830 Photonic Service Switch User Provisioning Guide* for more information.

b In the Optical Working Network Port Virtual Time Slot panel:

- Line Port
- Line VTS Number
- Ingress VTS Number
- Egress VTS Number

If the Flow Continuity Monitoring value for the OT Card is CCM, then the value of the Ingress VTS Number and Egress VTS Number parameters must be the same. See the *Alcatel-Lucent 1830 Photonic Service Switch User Provisioning Guide* for more information.

21 For line SVID configuration, configure the Line Port parameter in the Optical Protection Network Port Virtual Time Slot panel.

Note — For a Protected Service, the Protection Port VTS Parameters should be same as Line Port VTS Parameters.

22 After you configure the termination point for the NE, click on Optical Transport Service in the navigation tree. The General tab is displayed.**23** Configure the parameters in the VLAN Configuration Details panel:

- A-Ingress-Z-Egress CE-VLANID
- Z-Ingress-A-Egress CE-VLANID
- A-Egress-Z-Ingress Stack-VLANID
- A-Ingress-Z-Egress Stack-VLANID



Note — The A-Ingress-Z-Egress CE-VLANID and Z-Ingress-A-Egress CE-VLANID are not valid for a SubGige Full Rate Service.

- 24 Click on the OK button to save the configuration.



Note 1 – Only 11DPE12 cards support the following Card Rate Mode:

- FullRate
- SubRate
- QinQ

Note 2 – 11DPE12E and 11DPE12A cards support QinQ.

Note 3 – QinQ properties are displayed only after the termination points are created on the following cards.

- 11DPE12
- 11DPE12A
- 11DPE12E

See section 8.8 for more information about configuring the Card Rate Mode.

- 25 Repeat steps 15 to 24 for the other specified sites.



Note – Up to two sites can be specified to create an optical transport service. These are respectively named an A end site and a Z end site by the 5620 SAM.

Procedure 12-2 To create a multipoint transport service

Multipoint transport service is a drop and continue service which is primarily used to transmit video signals to multiple destinations. The client signals to be transmitted are added at the add Site. Some signals are dropped at the intermediate drop and continue sites. The remaining signals are dropped at the drop site.

- 1 Choose Create→Service→Optical→Create Multipoint Transport Service from the 5620 SAM main menu. The Multipoint Transport Service [Create] form opens.
- 2 Click on the Select button to choose a customer to associate with the multipoint transport service. The Select Customer - Multipoint Transport Service form opens.
- 3 Choose a customer for the multipoint transport service and click on the OK button. The Select Customer - Optical Transport Service form closes and the Multipoint Transport Service [Create] form reappears. The customer information appears in the Customer panel of the General tab.



Note – You can create a template for the service at operational state by using the Apply or OK button before you specify the optical sites and termination points. You can use the service template to create a service by adding optical sites and termination points. See the *5620 SAM Scripts and Templates Developer Guide* for the procedure to create a service from a template.

4 Configure the parameters:

- Service ID
- Auto-Assign ID
- Service Name
- Description
- Rate

Only the following rates are supported on 11DPM12 cards:

- unspecified
- 1GbE
- HDSDI
- SDSDI
- Service Priority
- Protection Type
 - Unprotected
 - ESNCP Protected
- Wavekey Assign Mode
 - Auto Keying (NE)
 - Auto Keying (NMS)
 - Unkeyed
- States
 - Administrative State
 - Operational State

5 Right-click on the Sites menu option in the Navigation tree and choose Create Add Site. The Select Network Elements - Multipoint Transport Service form opens with a list of available sites.

6 Choose a site. Click on the OK button.

7 Click on the site on the navigation tree. The Optical Site [Create] form opens and the General tab appears.

8 Click on the Termination Point tab to configure the termination point for the site.

9 Click on the Create button. The Termination Point [Create] form opens.

10 Click on the Select button. The Select Port - Termination Point form opens.

11 Choose a port and click on the OK button. The Select Port - Termination Point form closes and the Termination Point [Create] form reappears.



Note 1 – The form displays only the termination points that can be configured with the specified service rates.

Note 2 – The termination point does not appear in the Navigation tree when a termination point is:

- used in another service
- configured with another rate

12 Click on Multipoint Transport Service in the navigation tree.

- 13 Repeat steps 5 to 11 to add drop and continue sites and drop sites. For ESNCP service, add two drop sites. Click on the drop site and perform one of the following to set the type of path to working or protection path:
 - a Choose Working from the Path Type drop-down menu on the General tab of the Optical Site [Create] form.
 - b Choose Protection from the Path Type drop-down menu on the General tab of the Optical Site [Create] form.
- 14 To create path constraints, right-click on the drop site and choose Properties. The Optical Site [Create] form opens and the General tab appears.
- 15 Click on the Path Constraints tab. Optical Path Constraint [Create] form appears.
- 16 Click on the Select button. The Select Site - Optical Path Constraint form appears.
- 17 Choose the drop and continue sites as path constraints.
- 18 Click on the OK button. The select Site - Optical Path Constraint form closes.
- 19 Click on the OK button. The Optical Path Constraint [Create] form closes.



Note 1 – If the termination points are not added for any of the drop and continue sites during service creation, repeat steps 7 to 11 to add the termination points after the service is created. The path constraints are updated automatically.

Note 2 – If you need to delete any of the termination points in a drop and continue site, right-click on the termination point and choose Delete. The path constraints are updated automatically.

Procedure 12-3 To add a drop site on an unprotected multipoint service in a 11DPM12 card

- 1 On the navigation tree, right-click on the drop site and choose Extend Drop Site. The Select Network Elements form opens.
 - 2 Choose the site to add as drop site and click on the OK button. The dialog box opens displaying the IP address of the new drop site.
 - 3 Click on the OK button. The dialog box closes and Multipoint Transport Service [Edit] form reappears. The new drop site is added on the navigation tree.
 - 4 Right-click on the Termination point of the new site and choose Create Termination Point. The Termination Point [Create] form opens.
 - 5 Repeat steps 10 and 11 of Procedure 12-2 to add the termination point. Click on the Apply button on the Multipoint Transport Service [Edit] form. The previous drop site becomes a drop and continue site, and the path constraints are updated automatically.
-

Procedure 12-4 To delete a drop site on an unprotected multipoint service in a 11DPM12 card

- 1 On the navigation tree, right-click on the drop site and choose Delete. The drop site is removed from the navigation tree.
 - 2 Click on the Apply button of the Multipoint Transport Service [Create] form. The dialog box opens
 - 3 Click on the Yes button. The drop and continue site that is linked to the deleted drop site becomes the new drop site. The path constraints are updated automatically.
-

Procedure 12-5 To create dual stage multiplexing services on the 1830 PSS for keyed and unkeyed services

This procedure describes the dual stage multiplexing service support on the 1830 PSS 16/32 shelves for the following cards:

- 11STMM10 OTU1 client port (OT A) connected to a 4DPA4 line port (OT B). Up to four 4DPA4 OTs can be connected to one 11STMM10.
- 112SCX10 OTU2 client port (OT A) connected to a 11DPM12 line port (OT B). Up to ten 11DPM12 OTs can be connected to one 112SCX10.
- 112SNX10 OTU2 client port (OT A) connected to a 11DPM12 line port (OT B). Up to ten 11DPM12 OTs can be connected to one 112SNX10.
- 11DPM12 OTU1 client port (OT A) connected to a 4DPA4 line port (OT B). Up to four 4DPA4 OTs can be connected to one 11DPM12.
- 43SCX4 and 43SCX4E OTU2 client port (OT A) connected to a 11DPM12 line port (OT B). Up to four 11DPM12 OTs can be connected to one 43SCX4 or 43SCX4E.
- 43STX4P OTU2 client port (OT A) connected to a 11DPM12 line port (OT B). Up to four 11DPM12 OTs can be connected to one 43STX4P.

Prerequisites:

- An internal topological link is provisioned between the OT A client port and the OT B line port.
- The cross-connect terminates on the OT A line port. The OT B is not included in the cross-connect.
- Because there is no wave key encoding on OT B, the eVOA port is not used.
- There is no alarm correlation between OT A and OT B.



Note 1 – Dual Trans mode and Flex Mux mode are supported on the 4DPA4 card.

Note 2 – Keyed and Unkeyed services are supported in the Wavekey Assign Mode.

See Procedure [12-1](#) to create an optical service.

Figure 12-1 shows the dual stage multiplexing.

Figure 12-1 Dual stage multiplexing

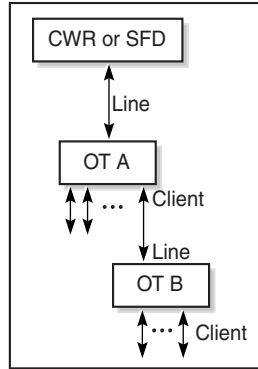

22756

Procedure 12-6 To create single fiber bidirectional support on the 1830 PSS-4/16/32 for unkeyed services

This procedure describes the CWDM single fiber bidirectional service support for the following fiber and OT cards:

- SFC-2
- SFC-4
- SFC-8
- 4DPA4
- 11STAR1
- 11STAR1A
- 11STMM10
- 11DPE12(E)

Prerequisites:

- The SFC should be connected in a OneFiber MuX mode. The default is TwoFiberMux. You must set the mode before you create an optical link. The mode can be configured on the Card Specifics tab of the Card [Edit] form. See Procedure 8-4 for more information.
- You can only create unidirectional internal optical links between the OT and filter channels.
- External optical links are always bidirectional. After the service is created, you can view the channel, frequency used, and direction in the topology view.

See Procedure 12-1 to create an optical service.

Administrative State

The transport service administrative state represents the aggregate value of the following:

- administrative states of the OCH cross connects in the service
- administrative state of the ports in service

If one of the administrative state values is not Up, the administrative state is set to Down. If all of the administrative state values are Up, the service administrative state is set to Up.

For unprotected services, you cannot change the administrative state of the service if there is a missing OCH cross connect for the service.

For protected services, you cannot change the administrative state of the service if there is a missing OCH cross connect on the working path and on the protecting path.

If the ODU trail is set to Admin Down or Admin Up, this sets the Admin down or Admin up on the OCH trails and the OCH cross connects.

Operational State

Transport service operational state and state causes are assigned separately for working paths and for protection paths. The operational state for a path represents the aggregate operational state of the OCH cross connects on the path and of the ports on that path. If any of the ports or the OCH cross connect is not Up on a path, the operational state for the path is Down.

The operational state of a path can be down due to the following state causes:

- Cross Connect Down—at least one of the cross connections on the path has an operational state set to Down
- Missing Cross Connect—there is a missing cross connect on the path
- Wavekey Mode Mismatch—there is a wavekey mismatch on the path
- Port (that is not part of CrossConnect) Down—a port that is not part of the cross connect is operationally down
- VTS Connection is Down
- Missing VTS Connection
- Missing ODUk Connection

The Complete Service button re-creates the cross connections and APS groups if there are missing entities and completes the creation of the service.



Note 1 – For OSPF configuration, see the Protocol Configuration chapter in the *5620 SAM User Guide*.

Note 2 – After an optical transport service is created, you can view the hops (ports) and OCH cross connects on the service path under working path, and protection path tabs.

Note 3 – You can view the Operational state causes on the General tab in the Protection or Working paths in the Services Path.

Procedure 12-7 To create an APS group

- 1 Choose Equipment from the navigation tree view selector. The navigation tree displays the Equipment view.
- 2 Choose Network→NE.
- 3 Right-click on the NE and choose Properties from the contextual menu. The Network Element [Edit] form opens with the General tab displayed.
- 4 Click on the APS Groups tab.
- 5 Click on the Create button. The APS Group [Create] form opens. Configure the parameters:
 - Description
 - Protection Mode
 - ESNCP
 - OPS
 - Optical Splitter
 - Card Sub Type



Note — Configure the parameters based on the card sub type. This is applicable only to ESNCP and Optical Splitter. See the *5620 SAM Optical Parameter Reference* for more information.

- Direction
 - Type
 - Wait To Restore (minutes)
- a When you set the Protection Mode parameter to ESNCP, configure the parameters based on the card sub type selected:
- | | |
|----------------------------------|--|
| • Card Sub Type | • Protection LO-ODUk facility |
| • Connection Direction | • Client Channel |
| - Bidirectional | • Working Port |
| - Unidirectional | • Working VTS (if the 11DPE12-11G Dual Port Pluggable GBE Mux card is selected) |
| • ODUk Protected Interface Type: | • Protection Port |
| - Client Port | • Protection VTS (if the 11DPE12-11G Dual Port Pluggable GBE Mux card is selected) |
| - ODU1PTF | |
| • ODU1 PTF | |
| • Client Port | |
| • Working LO-ODUk facility | |



Note 1 — Connection Direction and ODUk parameters are applicable only to 11DPM12 cards.

Note 2 — ODU1 PTF is applicable only if the ODUk Protected Interface Type is set to ODU1PTF)

- b When you set the Protection Mode parameter to OPS, configure the parameters:
 - Working Port
 - Protection Port
 - c When you set the Protection Mode parameter to Optical Splitter, configure the parameters:
 - Card Sub Type
 - Direction
 - Working Port
 - Protection Port
- 6 Click on the OK button. The APS Group [Create] form closes.
 - 7 Click on the Close Window button. The Network Element [Edit] form closes.
-

Procedure 12-8 To change the protection switch for an APS group member

- 1 Choose Equipment from the navigation tree view selector. The navigation tree displays the Equipment view.
- 2 Choose Network→NE.
- 3 Right-click on the NE and choose Properties from the contextual menu. The Network Element [Edit] form opens with the General tab displayed.
- 4 Click on the APS Groups tab.
- 5 The APS Group [Edit] form opens.
- 6 Choose an APS Group on the working or the protected paths and click on the Properties button.
- 7 Click on the APS Group Members tab.
- 8 Choose an APS Group that has been created on the Working or the Protected paths and the members that are attached to these paths, and click on the Properties button.
- 9 The APS Group Member [Edit] form opens with the General tab displayed.

- 10 Change the Protection Switch based on whether you specify a working or protected path.
 - Protection Switch
 - Clear
 - Forced Switch to Protection
 - Forced Switch to Working
 - Manual Switch to Protection
 - Manual Switch to Working
 - No Cmd
 - Protection Lockout
- 11 Click on the OK button. The APS Group [Create] form closes.
- 12 Click on the Close Window button. The Network Element [Edit] form closes.



Note — You can view the active path from A to Z and Z to A directions on the General tab of the Optical Transport Service [Edit] form.

Procedure 12-9 To configure a port-timeslot assignment on channelized cards

- 1 Right-click on a channelized port and choose Properties. The Physical Port [Edit] form opens with the General tab displayed.
 - 2 Click on the Port Specifics tab.
 - 3 Configure the Assigned Rate parameter. See the *5620 SAM Optical Parameter Reference*.
 - 4 Click on the Configure Timeslots button. The Timeslot Assignments form opens.
 - 5 Choose the required timeslot configuration. Click on the OK button. The Timeslot Assignments form closes.
 - 6 Click on the OK button. The Physical Port [Edit] form closes.
-

Procedure 12-10 To manually configure an ODU timeslot assignment for 11DPM12 cards

The 11DPM12 card supports 12 client ports, three ports form a port group. Each port group has 5Gb/s capacity. If the capacity is reached, the 5620 SAM displays a deployment error (1xODU0+1xODU1+1xODU0= 5Gb/s).

Prerequisites:

- ODU1PTF and port group association, with OPTSG mapping container for STM-1/OC-3 and STM-4/OC-12 clients:
 - ODU1PTF-1 and ODU1PTF-2 are used with port group 1 (C1, C2, and C3)
 - ODU1PTF-2 and ODU1PTF-3 are used with port group 2 (C4, C5, and C6)
 - ODU1PTF-3 and ODU1PTF-4 are used with port group 3 (C7, C8, and C9)
 - ODU1PTF-7 and ODU1PTF-8 are used with port group 4 (C10, C11, and C12)
- A port group should not be configured as an OPTSG and LO-ODUk mapping.



Note — Alcatel-Lucent recommends that the OPTSG and LO-ODUk mapping within a port group is not configured. If you need to configure mixed OPTSG and LO-ODUk mapping within a port group, provision the ODU1PTF XC and OPTSG mapping and then provision the LO-ODUk mapping. For example, if C1 and C2 ports are provisioned within an ODU1PTF, and C3 in an ODU1 container, you must first provision the associated ODU1PTF XC. Next provision the client C1/C2 OPTSG XC. The final step is to provision C3 with LO-ODUk mapping. The system software can then calculate and allocate resources efficiently.

- 1 Choose Network→NE→Shelf→Card→Port to navigate to a client port.
- 2 Right-click on the port and choose Properties. The Physical Port [Edit] form opens with the General tab displayed.
- 3 Click on the Port Specifics tab.
- 4 Configure the Assigned Rate parameter. See the *5620 SAM Optical Parameter Reference*.



Note 1 — You do not need to assign a container for client ports. The container is automatically assigned after you configure the Assigned Rate parameter. By default the OPTSG container is listed for OC3 and OC12 clients. You can also configure the ODU0 container from the drop-down based on the requirement.

Note 2 — You cannot configure timeslots on client ports.

Note 3 — You can configure timeslots on line ports. The default is OTU2.

- 5 Click on the Configure Timeslots button. The Timeslot Assignments form opens.
- 6 Specify the required timeslot configuration. Table 12-3 lists the timeslot mapping.

Table 12-3 12xANY timeslot mapping

Client signal type	ODU0 XC (default)	ODU1 XC (TS)	ODUFlex XC (TS)	OPTSG XC (TS)
FC100	1	–	–	–
OC3/STM1	1	–	–	1
OC12/STM4	1	–	–	4
GbE	1	–	–	–
SDSDI	1	–	–	–
FE	1	–	–	–
OTU1	–	2	–	–
OC48/STM64	–	2	–	–
HDSDI	–	2	–	–
FC200	–	2	–	–
FC400	–	–	4	–
3GSDI	–	–	3	–

- 7 Click on the OK button. The Timeslot Assignments form closes.
- 8 Click on the OK button. The Physical Port [Edit] form closes.

Procedure 12-11 To discover the optical transport services

Transport Services are not discovered automatically during NE discovery. Perform this procedure after all 1830 PSS NEs are synchronized in 5620 SAM.

- 1 Choose Manage→Service→Services from the 5620 SAM main menu. The Manage Services form opens.
- 2 Click on the Discover Transport Services button. The Discover Transport Services form opens. A list of topology groups are displayed.
- 3 Choose the appropriate physical topology group that contains 1830 PSS services that require discovery.

- 4 Click on the OK button to discover the service. All services within the group are discovered. The discovered 1830 PSS services are displayed on the Manage Services form.



Note 1 – For very large networks, this process may take time to complete.

Note 2 – The following services can be discovered by the 5620 SAM:

- ESNCP Protected
 - OPS Protected
 - Unprotected
 - Y-cable Protected
-

Procedure 12-12 To unmanage an optical transport service

The user can unmanage an optical transport service using the 5620 SAM. The Unmanage Service operation will remove the Transport Service from the 5620 SAM. The service configuration on the NE is maintained as is.

- 1 Choose Manage→Service→Services from the 5620 SAM main menu.
- 2 Choose Optical Transport Service from the drop-down menu.
- 3 The Unmanage Service button appears.
- 4 Choose one or more transport services, and click on the Unmanage Services button.



Note – Before unmanaging the 1830 PSS NE, the user must unmanage or delete all transport services on that NE. The user needs to re-enter the service name once the service is re-discovered.

Procedure 12-13 To display services riding on external or internal optical links

- 1 From the Physical Topology - Network view, double-click on an external or internal optical link.
- 2 The Physical Link Group List form opens.
- 3 Select an external or internal optical link and click on Properties. The Optical link [Edit] form opens.

- 4 Choose the Optical Services tab and click on Search. A list of optical services riding on the selected link, are displayed.
- 5 Select a service and click on Properties, the Optical Transport Service [Edit] form opens and displays the properties of the service.



Note 1 – You can view optical services on an OCH cross connect. Right click on the NE→Properties→OCH CrossConnects→Select a cross connect→Properties. The OCH Cross Connect [Edit] form is displayed. Choose the Optical Services tab to view the optical services on the selected cross connect.

Note 2 – You can also view optical services on ports from the Physical Port [Edit] form by selecting the Optical Services tab.

Note 3 – The services must be discovered in 5620 SAM to be able to view services on the external and internal optical links, the OCH cross connect and the ports.

12.8 Managing optical power levels using the Wavelength Tracker

The wavelength tracker is an Alcatel-Lucent technology that allows the 1830 PSS NE to manage wavelengths at different stages of an optical path.

Each wavelength can be traced as it passes through the network, which allows you to ensure that the network connections are correct. A unique identifier, known as a wave key pair, is encoded onto each wavelength that enters the network through a 1830 PSS device. By detecting and identifying the encoded wave keys, the wavelength can be traced through the network. Tables 12-4, 12-5, and 12-6 list the ITU channel numbers and corresponding ALU wave keys for the L-band, C-band, and S-band channels.

Table 12-4 L-band channel wavekeys

ITU channel number (THz)	nm	ALU channel number	ITU channel number (THz)	nm	ALU channel number
100 GHz Grid			50 GHz Offset		
186.00	1611.79	8600	186.05	1611.35	8605
186.10	1610.92	8610	186.15	1610.49	8615
186.20	1610.06	8620	186.25	1609.62	8625
186.30	1609.19	8630	186.35	1608.76	8635
186.40	1608.33	8640	186.45	1607.90	8645
186.50	1607.47	8650	186.55	1607.04	8655

(1 of 3)

ITU channel number (THz)	nm	ALU channel number	ITU channel number (THz)	nm	ALU channel number
100 GHz Grid			50 GHz Offset		
186.60	1606.60	8660	186.65	1606.17	8665
186.70	1605.74	8670	186.75	1605.31	8675
186.80	1604.88	8680	186.85	1604.46	8685
186.90	1604.03	8690	186.95	1603.60	8695
187.00	1603.17	8700	187.05	1602.74	8705
187.10	1602.31	8710	187.15	1601.88	8715
187.20	1601.46	8720	187.25	1601.03	8725
187.30	1600.60	8730	187.35	1600.17	8735
187.40	1599.75	8740	187.45	1599.32	8745
187.50	1598.89	8750	187.55	1598.47	8755
187.60	1598.04	8760	187.65	1597.62	8765
187.70	1597.19	8770	187.75	1596.76	8775
187.80	1596.34	8780	187.85	1595.91	8785
187.90	1595.49	8790	187.95	1595.06	8795
188.00	1594.64	8800	188.05	1594.22	8805
188.10	1593.79	8810	188.15	1593.37	8815
188.20	1592.95	8820	188.25	1592.52	8825
188.30	1592.10	8830	188.35	1591.68	8835
188.40	1591.26	8840	188.45	1590.83	8845
188.50	1590.41	8850	188.55	1589.99	8855
188.60	1589.57	8860	188.65	1589.15	8865
188.70	1588.73	8870	188.75	1588.30	8875
188.80	1587.88	8880	188.85	1587.46	8885
188.90	1587.04	8890	188.95	1586.62	8895
189.00	1586.20	8900	189.05	1585.78	8905
189.10	1585.36	8910	189.15	1584.95	8915
189.20	1584.53	8920	189.25	1584.11	8925
189.30	1583.69	8930	189.35	1583.27	8935
189.40	1582.85	8940	189.45	1582.44	8945
189.50	1582.02	8950	189.55	1581.60	8955
189.60	1581.18	8960	189.65	1580.77	8965
189.70	1580.35	8970	189.75	1579.93	8975
189.80	1579.52	8980	189.85	1579.10	8985
189.90	1578.69	8990	189.95	1578.27	8995

(2 of 3)

ITU channel number (THz)	nm	ALU channel number	ITU channel number (THz)	nm	ALU channel number
100 GHz Grid			50 GHz Offset		
190.00	1577.86	9000	190.05	1577.44	9005
190.10	1577.03	9010	190.15	1576.61	9015
190.20	1576.20	9020	190.25	1575.78	9025
190.30	1575.37	9030	190.35	1574.95	9035
190.40	1574.54	9040	190.45	1574.13	9045
190.50	1573.71	9050	190.55	1573.30	9055
190.60	1572.89	9060	190.65	1572.48	9065
190.70	1572.06	9070	190.75	1571.65	9075
190.80	1571.24	9080	190.85	1570.83	9085
190.90	1570.42	9090	190.95	1570.01	9095

(3 of 3)

Table 12-5 C-band channel wavekeys

ITU channel number (THz)	nm	ALU channel number	ITU channel number (THz)	nm	ALU channel number
100 GHz Grid			50 GHz Offset		
191.00	1569.59	9100	191.05	1569.18	9105
191.10	1568.77	9110	191.15	1568.36	9115
191.20	1567.95	9120	191.25	1567.54	9125
191.30	1567.13	9130	191.35	1566.72	9135
191.40	1566.31	9140	191.45	1565.90	9145
191.50	1565.50	9150	191.55	1565.09	9155
191.60	1564.68	9160	191.65	1564.27	9165
191.70	1563.86	9170	191.75	1563.45	9175
191.80	1563.05	9180	191.85	1562.64	9185
191.90	1562.23	9190	191.95	1561.83	9195
192.00	1561.42	9200	192.05	1561.01	9205
192.10	1560.61	9210	192.15	1560.20	9215
192.20	1559.79	9220	192.25	1559.39	9225
192.30	1558.98	9230	192.35	1558.58	9235
192.40	1558.17	9240	192.45	1557.77	9245
192.50	1557.36	9250	192.55	1556.96	9255
192.60	1556.55	9260	192.65	1556.15	9265
192.70	1555.75	9270	192.75	1555.34	9275

(1 of 2)

ITU channel number (THz)	nm	ALU channel number	ITU channel number (THz)	nm	ALU channel number
100 GHz Grid			50 GHz Offset		
192.80	1554.94	9280	192.85	1554.54	9285
192.90	1554.13	9290	192.95	1553.73	9295
193.00	1553.33	9300	193.05	1552.93	9305
193.10	1552.52	9310	193.15	1552.12	9315
193.20	1551.72	9320	193.25	1551.32	9325
193.30	1550.92	9330	193.35	1550.52	9335
193.40	1550.12	9340	193.45	1549.72	9345
193.50	1549.32	9350	193.55	1548.91	9355
193.60	1548.51	9360	193.65	1548.11	9365
193.70	1547.72	9370	193.75	1547.32	9375
193.80	1546.92	9380	193.85	1546.52	9385
193.90	1546.12	9390	193.95	1545.72	9395
194.00	1545.32	9400	194.05	1544.92	9405
194.10	1544.53	9410	194.15	1544.13	9415
194.20	1543.73	9420	194.25	1543.33	9425
194.30	1542.94	9430	194.35	1542.54	9435
194.40	1542.14	9440	194.45	1541.75	9445
194.50	1541.35	9450	194.55	1540.95	9455
194.60	1540.56	9460	194.65	1540.16	9465
194.70	1539.77	9470	194.75	1539.37	9475
194.80	1538.98	9480	194.85	1538.58	9485
194.90	1538.19	9490	194.95	1537.79	9495
195.00	1537.40	9500	195.05	1537.00	9505
195.10	1536.61	9510	195.15	1536.22	9515
195.20	1535.82	9520	195.25	1535.43	9525
195.30	1535.04	9530	195.35	1534.64	9535
195.40	1534.25	9540	195.45	1533.86	9545
195.50	1533.47	9550	195.55	1533.07	9555
195.60	1532.68	9560	195.65	1532.29	9565
195.70	1531.90	9570	195.75	1531.51	9575
195.80	1531.12	9580	195.85	1530.72	9585
195.90	1530.33	9590	195.95	1529.94	9595

(2 of 2)

Table 12-6 S-band channel wavekeys

ITU channel number (THz)	nm	ALU channel number	ITU channel number (THz)	nm	ALU channel number
100 GHz Grid			50 GHz Offset		
196.00	1529.55	9600	196.05	1529.16	9605
196.10	1528.77	9610	196.15	1528.38	9615
196.20	1527.99	9620	196.25	1527.60	9625
196.30	1527.22	9630	196.35	1526.83	9635
196.40	1526.44	9640	196.45	1526.05	9645
196.50	1525.66	9650	196.55	1525.27	9655
196.60	1524.89	9660	196.65	1524.50	9665
196.70	1524.11	9670	196.75	1523.72	9675
196.80	1523.34	9680	196.85	1522.95	9685
196.90	1522.56	9690	196.95	1522.18	9695
197.00	1521.79	9700	197.05	1521.40	9705
197.10	1521.02	9710	197.15	1520.63	9715
197.20	1520.25	9720	197.25	1519.86	9725
197.30	1519.48	9730	197.35	1519.09	9735
197.40	1518.71	9740	197.45	1518.32	9745
197.50	1517.94	9750	197.55	1517.55	9755
197.60	1517.17	9760	197.65	1516.78	9765
197.70	1516.40	9770	197.75	1516.02	9775
197.80	1515.63	9780	197.85	1515.25	9785
197.90	1514.87	9790	197.95	1514.49	9795
198.00	1514.10	9800	198.05	1513.72	9805
198.10	1513.34	9810	198.15	1512.96	9815
198.20	1512.58	9820	198.25	1512.19	9825
198.30	1511.81	9830	198.35	1511.43	9835
198.40	1511.05	9840	198.45	1510.67	9845
198.50	1510.29	9850	198.55	1509.91	9855
198.60	1509.53	9860	198.65	1509.15	9865
198.70	1508.77	9870	198.75	1508.39	9875
198.80	1508.01	9880	198.85	1507.63	9885
198.90	1507.25	9890	198.95	1506.87	9895
199.00	1506.49	9900	199.05	1506.12	9905
199.10	1505.74	9910	199.15	1505.36	9915
199.20	1504.98	9920	199.25	1504.60	9925

(1 of 2)

ITU channel number (THz)	nm	ALU channel number	ITU channel number (THz)	nm	ALU channel number
100 GHz Grid			50 GHz Offset		
199.30	1504.23	9930	199.35	1503.85	9935
199.40	1503.47	9940	199.45	1503.10	9945
199.50	1502.72	9950	199.55	1502.34	9955
199.60	1501.97	9960	199.65	1501.59	9965
199.70	1501.21	9970	199.75	1500.84	9975
199.80	1500.46	9980	199.85	1500.09	9985
199.90	1499.71	9990	199.95	1499.34	9995
200.00	1498.96	2000	200.05	1498.59	2000
200.10	1498.21	2001	200.15	1497.84	2001
200.20	1497.46	2002	200.25	1497.09	2002
200.30	1496.72	2003	200.35	1496.34	2003
200.40	1495.97	2004	200.45	1495.60	2004
200.50	1495.22	2005	200.55	1494.85	2005
200.60	1494.48	2006	200.65	1494.11	2006
200.70	1493.73	2007	200.75	1493.36	2007
200.80	1492.99	2008	200.85	1492.62	2008
200.90	1492.25	2009	200.95	1491.88	2009

(2 of 2)

In addition, the Wavelength Tracker can measure the optical power level at each detection point for each encoded channel that passes through a port on a 1830 PSS device. The 5620 SAM power management feature uses the wavelength tracker feature and other equipment readings to provide a graphical representation of power levels and a mechanism to track changes in the network.

For more information about the Wavelength Tracker tool, see the Alcatel-Lucent *1830 Photonic Service Switch User Provisioning Guide* and the Alcatel-Lucent *1830 Photonic Service Switch Product Information and Planning Guide*.

Service power graph

The Service power management graph displays all the points along the service path, on a single channel, for the selected direction. See Figure 12-2 for more information.

AutoKeying (NMS) is the only wavekey assign mode, (see Procedure 12-1 for more information), supported for services originating on the SR and traversing through a network of PSSs. The 5620 SAM assigns the wavekeys on the SR DWDM ports and on the PSS cross connects to ensure that the encoded wavekeys on the SR DWDM ports are the same as on the PSS. If the user changes the wavekeys using the WebUI or CLI interface, the user needs to ensure that the same wavekeys are assigned to respective SR source ports, in order to view the power levels accurately on the 1830 PSS encoder and decoder points.



Note – The 5620 SAM does not allow manual modification of wave keys. This modification has to be done using the WebUI or CLI interface.

The color legends used on the service power graph are as follows:

- Green indicates it is within range
- Orange indicates out of range (OoR but within the graph interval which ranges from -30 to +10)
- White indicates, the power levels are -99 and less than -30
- Black indicates the power levels are -99

Figure 12-2 Service power graph

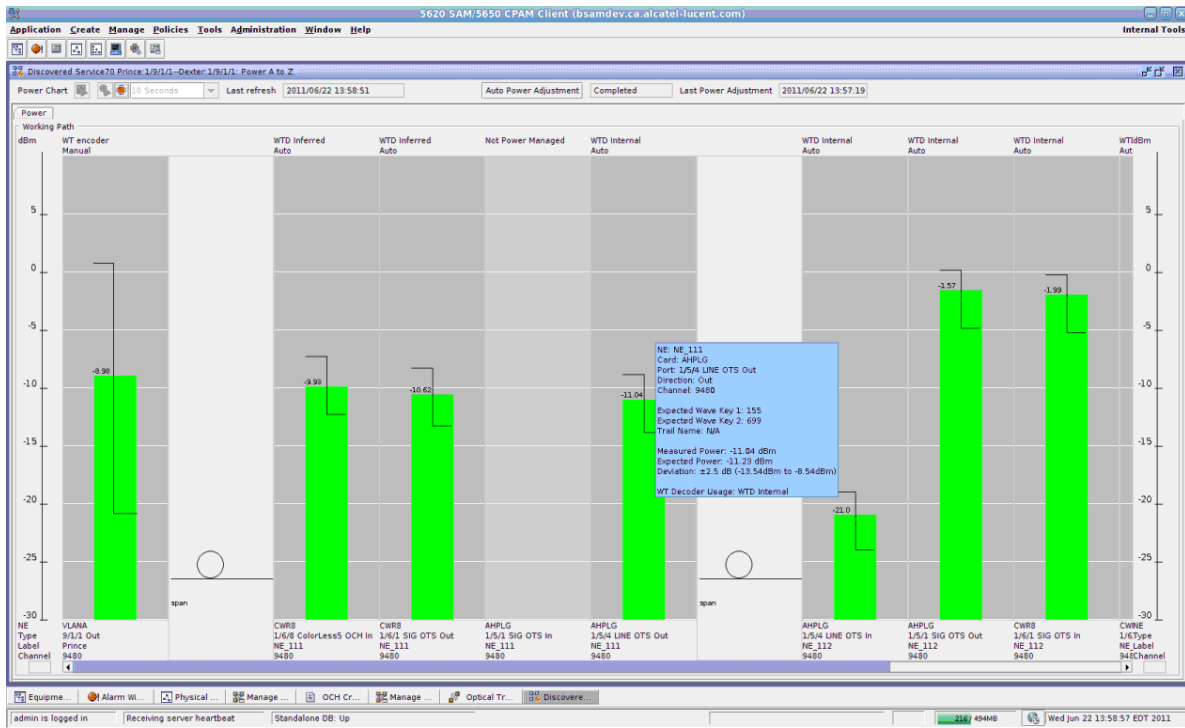

Port power graph

The port power graph displays three power values for each wavelength (direction (IN or OUT) and a port) as follows:

- measured power—a measurement that provides the current power level
- expected power—a provisioned value that indicates to the NE what power level should be achieved
- expected power deviation—a provisioned value that represents the deviation from the expected power level that is considered healthy

In automatically powered equipment, the expected power and deviation values are determined by SCOT. In manually powered equipment, the user can change these values.

Optical power levels are represented by bars, and the high and low watermarks are represented by a Z bar. Figure 12-3 shows a port optical power graph.

The color legends used on the port power graph are as follows:

- Green for within range
- Orange for out of range (OoR, but within the graph interval which ranges from -30 to +10)

Figure 12-3 Port power graph

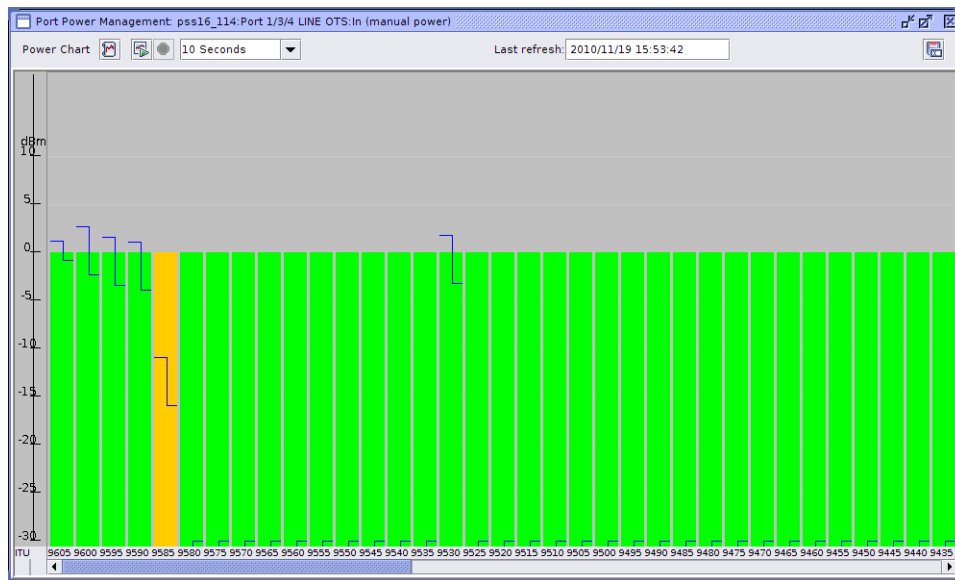

12.9 Procedures to manage optical power levels

The following procedures describe how to manage optical power levels.



Note – Power adjustments are supported for the following configurations:

- SR–PSS services (also supports SR DWDM tunable OTs)
- PSS–PSS services, where there is a drop shelf OT at the endpoints of the service
- PSS–PSS services, where there is an internal PSS OT but has a manual power adjustment

Procedure 12-14 To display optical power levels along a service path

- 1 Choose Manage→Service→Services from the 5620 SAM main menu. The Manage Services form opens.
- 2 Choose Optical Transport Service from the object type drop-down menu and click on the Search button. A list of managed optical transport services is displayed.
- 3 Choose a service and click on the Properties button. The Optical Transport Service [Edit] form opens.
- 4 Choose Service Paths→Service Path. The Service Path properties form opens. Click on one of the following buttons:
 - Power A to Z
 - Power Z to A

If these buttons are not visible, click on the More Actions button and choose the corresponding option from the drop-down menu.

The optical power level graph opens, displaying all the points along the service path for the selected direction.

Procedure 12-15 To refresh the optical power graph display

- 1 Open an optical power graph. See Procedure 12-14 for more information.
 - 2 Choose the number of seconds between refreshes from the Real-time Polling Interval (Seconds) drop-down menu.
 - 3 Perform one of the following:
 - a To configure an automatic refresh, choose the number of seconds between refreshes from the Real-Time Polling Interval (Seconds) drop-down menu and click on the Auto-refresh power chart icon.

The optical power graph updates at the configured time interval.
 - b To manually refresh the optical power graph, click on the Refresh power chart button, the latest power readings for all points, are displayed.

The optical power graph is refreshed and the Last refresh time is displayed.
-

Procedure 12-16 To configure auto power adjustment rules

The Auto Power Adjustment Rules allow users to configure parameters to adjust power levels for optical transport services between the source port and the target port.



Note — Power converge parameters for source and destination ports can be configured using the auto power adjustment rules. For example, the 7750 SR source port, which is the SR DWDM tunable power control enabled transponder port that can encode wavekeys, and the 1830 PSS target port which is the cross-connected egress amplifier port that can decode wavekeys, for a channel in A→Z or Z→A.

- 1 Choose Manage→Service→Services from the 5620 SAM main menu. The Manage Services form opens.
- 2 Choose Optical Transport Service from the object type drop-down menu and click on the Search button. A list of managed optical transport services is displayed.
- 3 Choose a service and click on the Properties button. The Optical Transport Service [Edit] form opens.
- 4 Choose Service Paths→Service Path. The Service Path properties form opens.
- 5 Click on the Search button in the Auto Power Adjustment Rules panel. A list of rules is displayed.
- 6 Choose a rule and click on the Properties button. The Power Adjustment Rule [Edit] form opens.
- 7 Configure the parameters:
 - Source Port
 - Target Port

In the Source Port panel, configure:

- Initial Target Power (dB)
- Power Converge Wait Time (seconds)
- Power Converge Retries
- Power Converge Deviation (dB)

In the Target Port panel, configure:

- Power Converge Deviation (dB)

- 8 Click on OK to apply the changes and close the Power Adjustment Rule [Edit] form.
- 9 Click on the Power Working A to Z or Power Working Z to A button. If these buttons are not visible, click on the More Actions button and choose the corresponding option from the drop-down menu. The Discovered Service Power A to Z or Z to A form opens.
- 10 Click on the Auto Power Adjustment button to implement automatic power adjustment. A dialog box opens.
- 11 Click on the Yes button. The automatic power adjustment process starts and the status button next to the Auto Power Adjustment button changes from Not Executed to In Progress.



Note — To terminate the automatic power adjustment process, click on the Auto Power Adjustment button. A dialog box opens. Click Yes and the automatic power adjustment process stops. The Auto Power Adjustment button now changes to Abort Power Adjustment and the status button changes from In Progress to Aborted.

Procedure 12-17 To manage expected power level and deviation at a Wavelength Tracker detection point

- 1 Choose Equipment from the view selector in the navigation tree. The navigation tree displays the Equipment view.
- 2 Right-click on a port object in the Equipment view and choose Properties from the contextual menu. The Physical Port (Edit) form opens with the General tab displayed. Table 12-7 lists the ports that support the Wavelength Tracker.

Table 12-7 Wavelength Tracker-enabled ports

Card	Port	Direction
Decoder Ports		

(1 of 2)

Card	Port	Direction
A2325A AHPHG AHPLG ALPHG AM2017B AM2325B	LINE	IN, OUT
	SIG	OUT
	DCM	OUT
AM2125A	LINEIN	IN
	LINEOUT	OUT
CWR8 CWR8-88	SIG	IN, OUT
	THRU	OUT
	OMD	IN
	CLS (1 to 8)	IN, OUT
OPSA, Protection Mode = OCHP or OMSP only	SIG	IN
	A	IN
	B	IN
Encoder Ports		
112SCA1	L1	OUT
112SCX10	L1	OUT
11DPE12 11DPE12E	VA (1 to 2)	OUT
11QPA4	VA (1 to 4)	OUT
11STAR1	L1	OUT
11STAR1A	L1	OUT
11STGE12	L1	OUT
11STMM10	L1	OUT
43SCX4 43SCX4E	L1	OUT
43STA1P	L1	OUT
43STX4 43STX4P	L1	OUT
4DPA4	VA (1 to 2)	OUT
MVAC	G (1 to 8)	OUT
SVAC	L1	OUT
Other Ports		
WTOCM	IN (1 to 4)	IN

(2 of 2)

- 3 Perform one of the following:
 - a Click on the Choose Power Management In button to view the detection point power levels for the inbound optical light path. The Port Power Management power chart for the inbound optical light path opens.
 - b Click on the Choose Power Management Out button to view the detection point power levels for the outbound optical light path. The Port Power Management power chart for the outbound optical light path opens.

If these buttons are not visible, click on the More Actions button and choose the corresponding option from the drop-down menu.
- 4 To set the expected power level for a channel, right-click and choose properties or double click on the Z bar to set the expected power levels so that the expected power level value falls in the middle of the Z bar.
- 5 Right-click on the Z bar and choose Set Power Deviation from the contextual menu. The Set Power Deviation for channel form is displayed.
- 6 To set the power deviation, perform one of the following:
 - a Enter a deviation value between 0 and 5 and click the Apply button.
 - b Drag the slide bar left or right to choose a deviation value and click the Apply button.

The Set Power Deviation for channel form closes and the size of the Z bar increases or decreases based on the configured deviation value.

Procedure 12-18 To export optical power graph data to a CSV file

- 1 Choose Equipment from the view selector in the navigation tree. The navigation tree displays the Equipment view.
- 2 Right-click on a port object in the Equipment view and choose Properties from the contextual menu. The Physical Port (Edit) form opens with the General tab displayed.
- 3 Perform one of the following:
 - a Click on the Choose Power Management In button to view the detection point power levels for the inbound optical light path. The Port Power Management power chart for the inbound optical light path opens.
 - b Click on the Choose Power Management Out button to view the detection point power levels for the outbound optical light path. The Port Power Management power chart for the outbound optical light path opens.

If these buttons are not visible, click on the More Actions button and choose the corresponding option from the drop-down menu.

- 4 Click on the export power values to CSV file button. The Save As window opens.
- 5 Choose the appropriate location for the file and click the Save button. The Save As window closes and the CSV file that contains the optical power level data is saved.

12.10 OTN Trails

The OTN is a fiber-optic network designed to transport customer traffic through an SDH or a SONET network. You can manage, create, or delete OTN trails using the 5620 SAM GUI.

Procedure 12-19 To create an ODU trail



Note 1 — You can create ODU trails between 1830 PSS NEs and between core NEs such as the 7750 SR.

Note 2 — Auto Keying (NE) is not supported on the 7750 SR.

- 1 Choose Manage→OTN Trails from the 5620 SAM main menu. The Manage OTN Trails form opens.
- 2 Choose the Create→Create ODU Trail. The Optical Connection, ODU Trail Creation [Create] form opens.
- 3 Configure the parameters in the Connection Info panel:
 - Rate
 - OTU1
 - OTU2
 - OTU3
 - OTU4
 - Wave Key Assign Mode
 - Auto Keying (NE)
 - Auto Keying (NMS)
 - Unkeyed
 - Bidirectional
 - Admin State
 - Protection State
- 4 Choose the endpoints for Port A and Port Z in the EndPoint Ports A and Z panel.
- 5 Click on Select Port A or Port Z button. The Select Port A or Z- Optical Connection - ODU Trail Creation form opens.
- 6 Click on the Search tab. A list of ports are displayed
- 7 Choose a port and click on the OK button. The Select Port A or Z- Optical Connection - ODU Trail Creation form closes and the Optical Connection, ODU Trail Creation [Create] form reappears.

- 8 Choose Create in the Path Constraints panel. The Constraint [Create] form opens.



Note — Path Constraint configuration is optional to the user.

- 9 Configure the parameters:
 - Constraint Type
 - Exclusion
 - Inclusion
 - Constraint Element
 - Port
 - Site
 - Trail
- 10 Choose one of the following:
 - a Port
 - i Click on the Select tab. The Select Port–Constraint null form opens.
 - ii Click on the Search button. A list of ports are displayed.
 - iii Choose a port and click on the OK tab. The form closes and the Constraint null [Create] form reappears.
 - b Site
 - i Click on the Select tab. The Select Site–Constraint null form opens.
 - ii Click on the Search button. A list of sites are displayed.
 - iii Choose a site and click on the OK tab. The form closes and the Constraint null [Create] form reappears.
 - c Trail
 - i Click on the Select tab. The Select Trail–Constraint null form opens.
 - ii Click on the Search button. A list of trails are displayed.
 - iii Choose a trail and click on the OK tab. The form closes and the Constraint null [Create] form reappears.
- 11 Click on the OK button. The Optical Connection, ODU Trail Creation [Create] form closes.



Note — When the ODU trail is created, the OCH trails are automatically created.

Procedure 12-20 To delete an ODU trail

- 1 Choose Manage→OTN Trails from the 5620 SAM main menu. The Manage OTN Trails form opens.
- 2 Choose ODU Trail (Optical Management) from the OTN Trail (Optical Management) drop-down menu.
- 3 Click on the Search button. The ODU trails are listed.
- 4 Choose the trail that you need to delete and click on the Delete button. A dialog box opens if the services are riding on an ODU trail.



Note 1 – When an ODU trail is deleted, OCH trails and OCH cross connects are deleted. Services are not deleted.

Note 2 – If services are riding on an ODU trail, the ODU trail is not deleted. An error message is displayed.

- 5 Click on the Yes button. The ODU trail is deleted.
-

Procedure 12-21 To configure an ODU trail

- 1 Choose Manage→OTN Trails from the 5620 SAM main menu. The Manage OTN Trails form opens.
 - 2 Choose ODU Trail (Optical Management) from the OTN Trail (Optical Management) drop-down menu.
 - 3 Click on the Search button to list the ODU trails.
 - 4 Choose an ODU trail and click on the Properties tab. The ODU Trail [Edit] form opens.
 - 5 Configure the parameters as required. See the *5620 SAM Optical Parameter Reference* and the *5620 SAM Parameter Guide* for more information.
 - 6 Click on the Apply button to save the changes.
 - 7 Click on the OK button to close the ODU Trail [Edit] form.
-

Procedure 12-22 To view the optical channel usage

- 1 Choose Manage→OTN Trails from the 5620 SAM main menu. The Manage OTN Trails form appears.
 - 2 Choose Optical Channel Usage (Optical Management) from the OTN Trail (Optical Management) drop-down menu, and click on the Search button. The optical channel usage list appears.
-

Procedure 12-23 To create an ODUk XC on the 11DPM12 card

- 1 Choose Equipment from the navigation tree view selector. The navigation tree displays the Equipment view.
 - 2 Right-click on the NE where you want to create the ODUk cross connects and select Properties from the contextual menu. The Network Element (Edit) form opens with the General tab displayed.
 - 3 On the Network Element [Edit] form navigation tree, expand the Shelf icon.
 - 4 Right-click on the card and select Properties from the contextual menu. The Card Slot [Edit] form opens.
 - 5 Click on the ODU1PTF Objects tab. A list of ODU1PTF cross connects are displayed.
 - 6 Select an ODU1PTF cross connect and click on Properties. The ODU1PTF [Edit] form opens.
 - 7 Click on the Associate Line Side LO-ODUk Facility tab. The ODU1Ptf Association with Line side LO-ODUk [Create] form opens.
 - 8 Click on Select in the Line Side LO-ODUk Facility panel. The Select Line Side LO-ODUk Facility form opens with a list of available Line Side LO-ODUks.
 - 9 Select a Line Side LO-ODUk Facility and click the OK button. The ODU1Ptf Association with Line side LO-ODUk [Create] form reappears.
 - 10 Choose a Direction from the drop-down menu.
 - 11 Click on the OK or Apply button. A dialog box appears. Select the check box and click on Yes. This action results in changing the cross-connects on the NE, associates the client port and the line port, and creates the ODUk XC.
-

Procedure 12-24 To delete an ODUk XC on the 11DPM12 card

- 1 Choose Equipment from the navigation tree view selector. The navigation tree displays the Equipment view.
 - 2 Right-click on the NE where you want to delete the ODUk XC and select Properties from the contextual menu. The Network Element (Edit) form opens with the General tab displayed.
 - 3 Click on the ODUk Cross Connects tab. A list of ODUk XCs are displayed. Select the cross connect to be deleted and click on the Delete button. A dialog box appears. Select the check box and click on Yes. This action results in deleting the ODUk XC which disassociates the client port from the line port.
-

1830 PSS maintenance using the 5620 SAM

13 — 1830 PSS troubleshooting

13 – 1830 PSS troubleshooting

- 13.1 Troubleshooting overview 13-2**
- 13.2 Fault management 13-2**
- 13.3 Ethernet OAM 13-3**
- 13.4 Alarm management 13-4**

13.1 Troubleshooting overview

Fault management is a set of functions that allows detection, isolation, and correction of abnormal operations in a telecommunication network. Alarm reporting is the notification sent to external management systems for internally detected faults. The fault processing and alarm reporting functions are part of the supervision function of the NE that monitors and manages the NE transmission resources (logical or physical facilities and the associated equipment modules).

13.2 Fault management

The 1830 PSS-32 / 1830 PSS-16 is provisionable on a per-port basis to detect process, report faults, failures, and performance. Equipment faults can be diagnosed down to an FRU or interface.

There is one system default alarm profile that contains all alarms or conditions supported in the system and their severity, Critical, Major, Minor. The user can change the severity of alarms on each port or facility independently or point to the system profile. The system profile can be modified or reset to factory defaults.

The 5620 SAM correlates the events and alarms against the managed equipment and configured services and policies. The 5620 SAM applies the alarms against the appropriate equipment and services. A correlated alarm refers to an alarm that causes fault conditions for many objects. For example, if an alarm occurs because a port goes down, all services that use the port receive notification of the alarm.

You can view the alarm from the service configuration form or from the subscriber information form that lists the affected service. All object information forms contain a faults tab, which lists the alarms that affect the object. All alarms appear in the alarm list of the 5620 SAM GUI. See the *1830 Photonic Service Switch 36/32/16 Product Information and Planning Guide*, the *5620 SAM User Guide*, and the *5620 SAM Troubleshooting Guide* for more information about fault and alarm management. See the *5620 SAM Alarm Reference* for a list of the alarms that the 5620 SAM can raise against the 1830 PSS.

User activity logging

The 5620 SAM logs each GUI and OSS user action, such as 1830 PSS object configuration, in the 5620 SAM database. The User Activity form lists the recent actions; older actions are purged according to configurable retention limits. For more information about the user activity log and configuring the log retention, see the *5620 SAM User Guide*.

13.3 Ethernet OAM

The 5620 SAM supports Ethernet OAM on the 11QPE24 card on the Ethernet Optical transport services, such as 802.1ag, Y.1731 and 802.3ah. Ethernet OAM defines the Operations, Administration, and Maintenance sub-layer, which is used for monitoring link operations such as remote fault indication and remote loopback control. OAM provides network operators the ability to monitor the health of the network and determine the location of failing links or fault conditions. EFM OAM provides data link layer mechanisms that complement applications that may reside in higher layers.

OAM information is transported in slow protocol frames which are called OAM protocol data units (OAMPDUs). OAMPDUs contain the appropriate control and status information used to monitor, test and troubleshoot EFM OAM-enabled links. OAMPDUs traverse a single link, that is passed between peer OAM entities, and are not forwarded by MAC clients (like bridges or switches), unless configured.

The following EFM OAM functions are supported on the 11QPE24 card:

- EFM OAM capability discovery
- active and passive modes
- remote failure indication
- local and remote loopbacks
- EFM OAMPDU tunneling
- high-resolution EFM OAM timers (500 ms interval)

See the *5620 SAM User Guide* for more information.

Ethernet CFM

Ethernet Connectivity Fault Management (CFM) supports end-to-end service management in an L2 network. CFM tools provide path discovery and fault detection, isolation, and notification. See the *5620 SAM User Guide* for more information about how to configure an IEEE 802.1ag-enabled network for Ethernet CFM.

Table 13-1 lists the supported Ethernet CFM test types, the objects against which the tests can be performed, the test types, and the network layer being tested.

Table 13-1 Ethernet CFM test types and test objects

Network level	Test type	Network object or service component for test
Ethernet	CFM Loopback	SAP or Ethernet Ring Path End Point
	CFM Link trace	
	CFM Two Way Delay	
	CFM Two Way Synthetic Loss Measurement (SLM)	

The following CFM diagnostic tests detect connectivity failure.

CFM loopback

CFM loopback messages are sent to a unicast destination MAC address. The MEP at the destination responds to the loopback message with a loopback reply. A MEP or a MIP can reply to a loopback message if the destination MAC address matches the MAC address of the MEP or MIP. CFM loopback tests verify connectivity to a specific MEP or MIP.

CFM link trace

CFM link trace messages that contain a target unicast MAC address are sent to multicast destination MAC addresses. Each MIP at the same MD level replies with a link trace response. Messages are forwarded to the next hop until they reach the destination MAC address. The originating MEP collects the replies to determine the path.

CFM two-way delay

The CFM two-way delay test applies only to Y.1731 MEPs. In this test, the frame delay is defined as the time elapsed since the start of transmission of the first bit of the frame by the source site until the frame is received by the same site after passing through the destination site. The frame delay represents the round-trip time between the source and destination sites.

CFM two-way SLM

The CFM two-way SLM test provides Synthetic Loss Measurement and it is used to check the packet loss.

13.4 Alarm management

The alarm-based fault management system provides the following:

- the correlation of alarms with equipment- and service-affecting faults
- updates to the managed-object operational status of equipment, services and interfaces in near-real-time
- alarm policy control that allows a network administrator to specify how to process alarms and how to create and store the alarm logs
- point-and-click alarm management using the 5620 SAM GUI dynamic alarm list and object properties forms
- the ability to log the actions taken to correct the associated fault by adding notes to the alarm
- an alarm history for performing trend analysis

See the *5620 SAM User Guide*, the *5620 SAM Alarm Reference*, and *1830 Photonic Service Switch 36/32/16 User Provisioning Guide* for more information.

Alarm status, severity, and aggregation

Alarm status for the network is indicated in the navigation tree, the dynamic alarm list, and on the topology maps. You can use the navigation tree to view the status of an alarm raised against a specific object and to view the aggregated alarm status. The aggregated alarm status is also available on the Faults tab of an object property form. See the *5620 SAM User Guide* for more information about aggregation and object alarms.

Alarm severity profiles can be configured at the NE, shelf, card slot and interface level. See the *5620 SAM User Guide* for more information.

Alarm suppression

The 5620 SAM does not raise alarms when numerous SNMP traps are sent in quick succession for the same type of event. This prevents alarm storms during intermittent outages in the network caused by bouncing NEs; for example, when links go up and down rapidly. The 5620 SAM continues to resynchronize the network, and if the bouncing NEs continue to send down state SNMP traps, the 5620 SAM eventually receives the trap and generates the appropriate alarm.

To indicate how often an alarm is raised, the number of occurrences of each instance of the alarm is tracked within the alarm record of the initial alarm. Click on the Statistics tab of an individual Alarm Info form to see how often the alarm was raised. See the *5620 SAM User Guide* for more information.

Customer documentation and product support

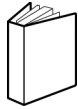

Customer documentation

<http://www.alcatel-lucent.com/myaccess>

Product manuals and documentation updates are available at [alcatel-lucent.com](http://www.alcatel-lucent.com). If you are a new user and require access to this service, please contact your Alcatel-Lucent sales representative.



Technical Support

<http://support.alcatel-lucent.com>



Documentation feedback

documentation.feedback@alcatel-lucent.com



© 2012-2013 Alcatel-Lucent. All rights reserved.

3HE 06986 AAAG TQZZA Edition 01