



# Alcatel-Lucent

Service Access Switch | Release 8.0 Rev.03

7210 SAS D, E, K OS  
OAM and Diagnostics Guide

3HE10390AAABTQZZA



Alcatel-Lucent - Proprietary & Confidential

Contains proprietary/trade secret information which is the property of Alcatel-Lucent. Not to be made available to, or copied or used by anyone who is not an employee of Alcatel-Lucent except when there is a valid nondisclosure agreement in place which covers such information and contains appropriate non-disclosure and limited use obligations.

Copyright 2015 © Alcatel-Lucent. All rights reserved. All specifications, procedures, and information in this document are subject to change and revision at any time without notice. The information contained herein is believed to be accurate as of the date of publication. AlcatelLucent



---

All specifications, procedures, and information in this document are subject to change and revision at any time without notice. The information contained herein is believed to be accurate as of the date of publication. Alcatel-Lucent provides no warranty, express or implied, regarding its contents. Users are fully responsible for application or use of the documentation.

Alcatel, Lucent, Alcatel-Lucent and the Alcatel-Lucent logo are trademarks of Alcatel-Lucent. All other trademarks are the property of their respective owners.

Copyright 2015 Alcatel-Lucent.

All rights reserved.

### **Disclaimers**

Alcatel-Lucent products are intended for commercial uses. Without the appropriate network design engineering, they must not be sold, licensed or otherwise distributed for use in any hazardous environments requiring fail-safe performance, such as in the operation of nuclear facilities, aircraft navigation or communication systems, air traffic control, direct life-support machines, or weapons systems, in which the failure of products could lead directly to death, personal injury, or severe physical or environmental damage. The customer hereby agrees that the use, sale, license or other distribution of the products for any such application without the prior written consent of Alcatel-Lucent, shall be at the customer's sole risk. The customer hereby agrees to defend and hold Alcatel-Lucent harmless from any claims for loss, cost, damage, expense or liability that may arise out of or in connection with the use, sale, license or other distribution of the products in such applications.

This document may contain information regarding the use and installation of non-Alcatel-Lucent products. Please note that this information is provided as a courtesy to assist you. While Alcatel-Lucent tries to ensure that this information accurately reflects information provided by the supplier, please refer to the materials provided with any non-Alcatel-Lucent product and contact the supplier for confirmation. Alcatel-Lucent assumes no responsibility or liability for incorrect or incomplete information provided about non-Alcatel-Lucent products.

However, this does not constitute a representation or warranty. The warranties provided for Alcatel-Lucent products, if any, are set forth in contractual documentation entered into by Alcatel-Lucent and its customers.

This document was originally written in English. If there is any conflict or inconsistency between the English version and any other version of a document, the English version shall prevail.

# Table of Contents

<b>Preface</b> .....	7
<b>Getting Started</b>	
Alcatel-Lucent 7210 SAS-Series Services Configuration Process .....	11
<b>Mirror Services</b>	
Service Mirroring .....	14
Mirror Implementation .....	15
Mirror Source and Destinations .....	16
Mirroring Performance .....	18
Mirroring Configuration .....	19
Configuration Process Overview .....	20
Configuration Notes .....	21
Configuring Service Mirroring with CLI .....	23
Mirror Configuration Overview .....	24
Defining Mirrored Traffic .....	24
Basic Mirroring Configuration .....	26
Mirror Classification Rules .....	27
Common Configuration Tasks .....	29
Configuring a Local Mirror Service .....	30
Service Management Tasks .....	32
Modifying a Local Mirrored Service .....	33
Deleting a Local Mirrored Service .....	34
Configuration Commands .....	41
<b>OAM and SAA</b>	
OAM Overview .....	60
Two-Way Active Measurement Protocol (TWAMP) .....	60
Configuration Notes .....	61
Ethernet Connectivity Fault Management (ETH-CFM) .....	62
ETH-CFM Building Blocks .....	64
Loopback .....	70
Linktrace .....	71
Continuity Check (CC) .....	73
Alarm Indication Signal (ETH-AIS Y.1731) .....	75
Test (ETH-TST Y.1731) .....	75
Y.1731 Time Stamp Capability .....	76
One-Way Delay Measurement (ETH-1DM Y.1731) .....	76
Two-Way Delay Measurement (ETH-DMM Y.1731) .....	77
Synthetic Loss Measurement (ETH-SL) .....	78
Configuration Example .....	80
ETH-CFM QoS Considerations .....	84
Configuration guidelines .....	84
OAM Mapping .....	85
CFM Connectivity Fault Conditions .....	85

## Table of Contents

CFM Fault Propagation Methods . . . . .	86
Epipe Services . . . . .	87
Fault Propagation to access dot1q/QinQ ports in Access-uplink mode . . . . .	88
Configuring Fault propagation: . . . . .	89
Service Assurance Agent Overview . . . . .	91
Traceroute Implementation . . . . .	91
NTP . . . . .	91
Ethernet CFM . . . . .	92
Writing SAA Results to Accounting Files . . . . .	92
Configuring SAA Test Parameters . . . . .	93
Y.1564 Testhead OAM tool . . . . .	94
Pre-requisites for using the Testhead Tool . . . . .	98
Generic pre-requisites for use of testhead tool (applicable for all 7210 SAS platforms): . . . . .	98
Configuration Guidelines . . . . .	102
Configuring testhead tool parameters . . . . .	106
Port Loopback for Ethernet ports . . . . .	108
SAP loopback for Ethernet SAPs . . . . .	108
Diagnostics Command Reference . . . . .	109
Tools Command Reference . . . . .	201
<b>Common CLI Command Descriptions</b>	
Common Service Commands . . . . .	224
<b>Standards and Protocol Support . . . . .</b>	<b>225</b>

# List of Tables

<b>Preface</b> .....	7
<b>Getting Started</b>	
Table 1: Configuration Process .....	11
<b>Mirror Services</b>	
Table 2: Mirroring support for 7210 SAS-D, 7210 SAS-E and 7210 SAS-K .....	18
Table 3: .....	18
Table 4: Mirror Source Port Requirements .....	27
<b>OAM and SAA</b>	
Table 5: ETH-CFM Support Matrix for 7210 SAS-D .....	66
Table 6: ETH-CFM Support Matrix for 7210 SAS-E .....	67
Table 7: ETH-CFM Support Matrix for 7210 SAS-K .....	67
Table 8: SAP Encapsulations supported for testhead on 7210 SAS-D .....	105
Table 9: Request Packet and Behavior .....	127
Table 10: Output fieldstools dump system-resource sap-ingress-qos .....	207
<b>Common CLI Command Descriptions</b>	

# List of Figures

## Mirror Services

Figure 1:	Service Mirroring	14
Figure 2:	Local Mirroring Example	19
Figure 3:	Mirror Configuration and Implementation Flow	20
Figure 4:	Local Mirrored Service Tasks	29

## OAM and SAA

Figure 5:	MEP and MIP	68
Figure 6:	MEP, MIP and MD Levels	69
Figure 7:	CFM Loopback	70
Figure 8:	CFM Linktrace	71
Figure 9:	CFM Continuity Check	73
Figure 10:	CFM CC Failure Scenario	73
Figure 11:	SLM Example	80
Figure 12:	Local Fault Propagation	89
Figure 13:	7210 acting as traffic generator and traffic analyzer	94

## Common CLI Command Descriptions

## About This Guide

This guide describes service mirroring and Operations, Administration and Management (OAM) and diagnostic tools provided by the 7210 SAS D, E, and K platforms and presents examples to configure and implement various tests.

On 7210 SAS devices, not all the CLI commands are supported on all the platforms and in all the modes. In many cases, the CLI commands are mentioned explicitly in this document. In other cases, it is implied and easy to know the CLIs that are not supported on a particular platform.

**NOTE:** 7210 SAS-E, 7210 SAS-D, and 7210 SAS-K operates in access-uplink mode by default. No explicit user configuration is needed for this.

This document is organized into functional chapters and provides concepts and descriptions of the implementation flow, as well as Command Line Interface (CLI) syntax and command usage.

---

## Audience

This manual is intended for network administrators who are responsible for configuring the 7210 SAS routers. It is assumed that the network administrators have an understanding of networking principles and configurations. Protocols, standards, and services described in this manual include the following:

- CLI concepts
- Subscriber services
- Service mirroring
- Operation, Administration and Maintenance (OAM) operations

## List of Technical Publications

The 7210-SAS-D, E, K OS documentation set is composed of the following books:

- 7210-SAS-D, E, K OS Basic System Configuration Guide  
This guide describes basic system configurations and operations.
- 7210-SAS-D, E, K OS System Management Guide  
This guide describes system security and access configurations as well as event logging and accounting logs.
- 7210-SAS-D, E, K OS Interface Configuration Guide  
This guide describes card, Media Dependent Adapter (MDA), LAG, and port provisioning.
- 7210-SAS-D, E, K OS Router Configuration Guide  
This guide describes logical IP routing interfaces and associated attributes such as an IP address, port as well as IP and MAC-based filtering.
- 7210-SAS-D, E, K OS OS Routing Protocols Guide  
This guide provides an overview of routing concepts and provides configuration examples for protocols and route policies.
- 7210-SAS-D, E, K OS,Services Guide  
This guide describes how to configure service parameters such as, customer information and user services.
- 7210-SAS-D, E, K OS OAM and Diagnostic Guide  
This guide describes how to configure features such as service mirroring and Operations, Administration and Management (OAM) tools.
- 7210-SAS-D, E, K OS Quality of Service Guide  
This guide describes how to configure Quality of Service (QoS) policy management.

## Technical Support

If you purchased a service agreement for your 7210 SAS and related products from a distributor or authorized reseller, contact the technical support staff for that distributor or reseller for assistance. If you purchased an Alcatel-Lucent service agreement, contact your welcome center.

Web: <http://www.alcatel-lucent.com/portal.html>



# Getting Started

---

## In This Chapter

This book provides process flow information to configure service mirroring and Operations, Administration and Management (OAM) tools.

---

## Alcatel-Lucent 7210 SAS-Series Services Configuration Process

[Table 1](#) lists the tasks necessary to configure mirroring, and perform tools monitoring functions.

This guide is presented in an overall logical configuration flow. Each section describes a software area and provides CLI syntax and command usage to configure parameters for a functional area.

**Table 1: Configuration Process**

Area	Task	Chapter
Diagnostics/ Service verification	Mirroring	<a href="#">Mirror Services on page 13</a>
	OAM	<a href="#">OAM and SAA on page 59</a>
Reference	List of IEEE, IETF, and other proprietary entities.	Standards and Protocols section.



# Mirror Services

---

## In This Chapter

This chapter provides information to configure mirroring.

Topics in this chapter include:

- [Service Mirroring on page 14](#)
- [Mirror Implementation on page 15](#)
  - [Mirror Source and Destinations on page 16](#)
    - [Local Mirroring on page 17](#)
  - [Mirroring Performance on page 18](#)
  - [Mirroring Configuration on page 19](#)
- [Configuration Process Overview on page 20](#)
- [Configuration Notes on page 21](#)
- [Configuring Service Mirroring with CLI on page 23](#)
- [Basic Mirroring Configuration on page 26](#)
- [Common Configuration Tasks on page 29](#)
- [Service Management Tasks on page 32](#)
- [Mirror Service Command Reference on page 37](#)
- [Configuration Commands on page 41](#)

## Service Mirroring

When troubleshooting complex operational problems, customer packets can be examined as they traverse the network. Alcatel-Lucent's service mirroring provides the capability to mirror customer packets to allow for trouble shooting and offline analysis.

This capability also extends beyond troubleshooting services. Telephone companies have the ability to obtain itemized calling records and wire-taps where legally required by investigating authorities. The process can be very complex and costly to carry out on data networks. Service Mirroring greatly simplifies these tasks, as well as reduces costs through centralization of analysis tools and skilled technicians.

Original packets are forwarded while a copy is sent out the mirrored port to the mirroring (destination) port. Service mirroring allows an operator to see the actual traffic on a customer's service with a sniffer sitting in a central location. In many cases, this reduces the need for a separate, costly overlay sniffer network.

7210 SAS devices configured in access-uplink mode support only local mirroring.

When using local mirroring user has an option to use NULL SAP or a dot1q SAP or a Q1.\* SAP as mirror destination. Use of Dot1q SAP or a Q1.\* SAP as the mirror destination allows the mirrored traffic to share the same uplink as the service traffic (when the uplinks are L2 based).

On some 7210 SAS platforms, when using Dot1q SAP or a Q1.\* SAP as the mirror destination user needs to dedicate the resources of a port for use with mirror application (see below for more details).

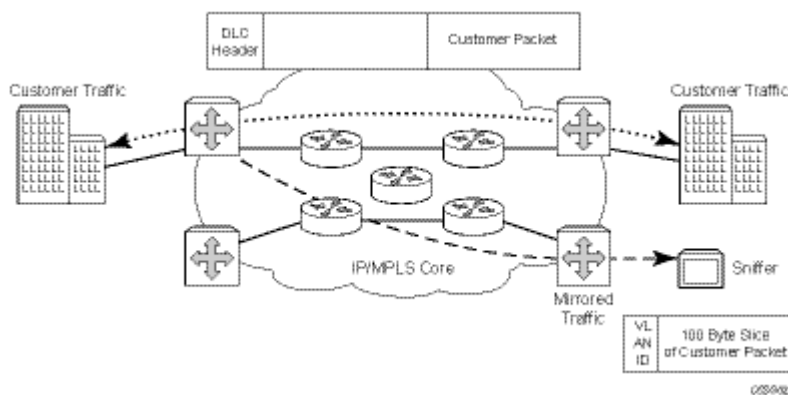

Figure 1: Service Mirroring

## Mirror Implementation

Mirroring can be configured on ingress or egress of certain service entities (For example: SAPs, ports, filter entries) and these are referred to as mirror sources. For more information, see the [“Mirror Source and Destinations on page 16”](#).

Alcatel-Lucent’s implementation of packet mirroring is based on the following assumptions:

- Ingress packets are mirrored as they appear on the wire (there are some exceptions to this, as documented below and in the Release Notes). This is important for troubleshooting encapsulation and protocol issues.

When mirroring at ingress the 7210 SAS node sends an exact copy of the original ingress packet to the mirror destination while normal forwarding proceeds on the original packet.

- On 7210 SAS-D,E, when mirroring at egress, the packets are not an exact copy of the forwarded packet. Specifically it does not contain the SAP tags that the forwarded copy of the packet carries, but carries an internal VLAN tag. Mirroring at egress takes place before the packet is processed by egress QoS. Therefore, there exists a possibility that a packet is dropped by egress QoS mechanisms (because of RED mechanisms and so on) and thus not forwarded but it is still mirrored.
- On 7210 SAS-K, when mirroring at egress, the packet are an exact copy of the forwarded packet. Mirroring at egress takes place after the packet is processed by egress QoS, but before the packet is sent out to the wire.

## Mirror Source and Destinations

Mirror sources and destinations have the following characteristics for 7210 SAS devices .

- Mirror source and mirror destination can be on the same node (local mirroring) .Each mirror destination should terminate on a distinct port carrying only null encapsulation or a Dot1q SAP or a Q1.\* SAP .
- They can only be on the same 7210 SAS node (local mirroring).
- A mirror destination can terminate on only one port (NULL SAP or dot1q SAP or a Q1.\* SAP).
- Packets ingressing a port can have a mirror destination separate from packets egressing another or the same port.

## Local Mirroring

The 7210 SAS devices allows multiple concurrent mirroring sessions so traffic from more than one ingress mirror source can be mirrored to the same or different mirror destinations. For more information, see the “[Configuration Notes on page 21](#)”.

## Mirroring Performance

Replication of mirrored packets can, typically, affect performance and should be used carefully.

The following tables mentions about the mirroring that can be performed based on the following criteria (that is, mirror sources):

**Table 2: Mirroring support for 7210 SAS-D, 7210 SAS-E and 7210 SAS-K**

<b>Mirroring</b>	<b>7210 SAS-D</b>	<b>7210 SAS-E</b>	<b>7210 SAS-K</b>
Port (ingress and egress)	Supported	Supported	Supported
SAP (ingress only)	Supported	Supported	Supported
MAC filter (ingress only)	Supported	Supported	Supported
IP filter (ingress only)	Supported	Supported	Supported
SAP egress	Not Supported	Not Supported	Supported

## Mirroring Configuration

Configuring mirroring is similar to creating a uni-direction service. Mirroring requires the configuration of:

- Mirror source — The traffic on a specific point(s) to mirror.
- Mirror destination — The location to send the mirrored traffic, where the sniffer will be located.

Figure 2 depicts a local mirror service configured on ALA-A.

- Port 1/1/2 is specified as the source. Mirrored traffic ingress and egressing this port will be sent to port 1/1/3.
- SAP 1/1/3 is specified as the destination. The sniffer is physically connected to this port. Mirrored traffic ingress and egressing port 1/1/2 is sent here. SAP, encapsulation requirements, and mirror classification parameters are configured.

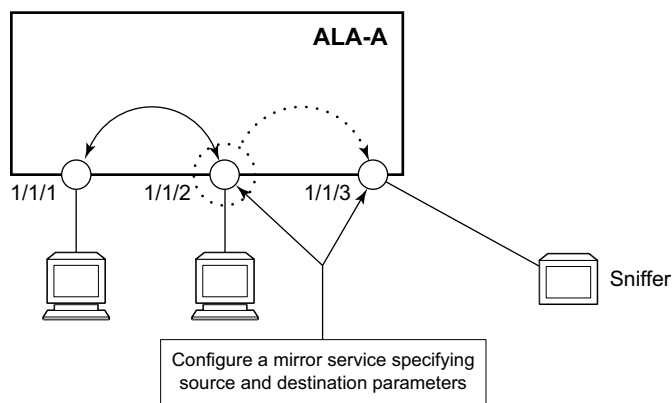

Figure 2: Local Mirroring Example

# Configuration Process Overview

Figure 3 displays the process to provision basic mirroring parameters.

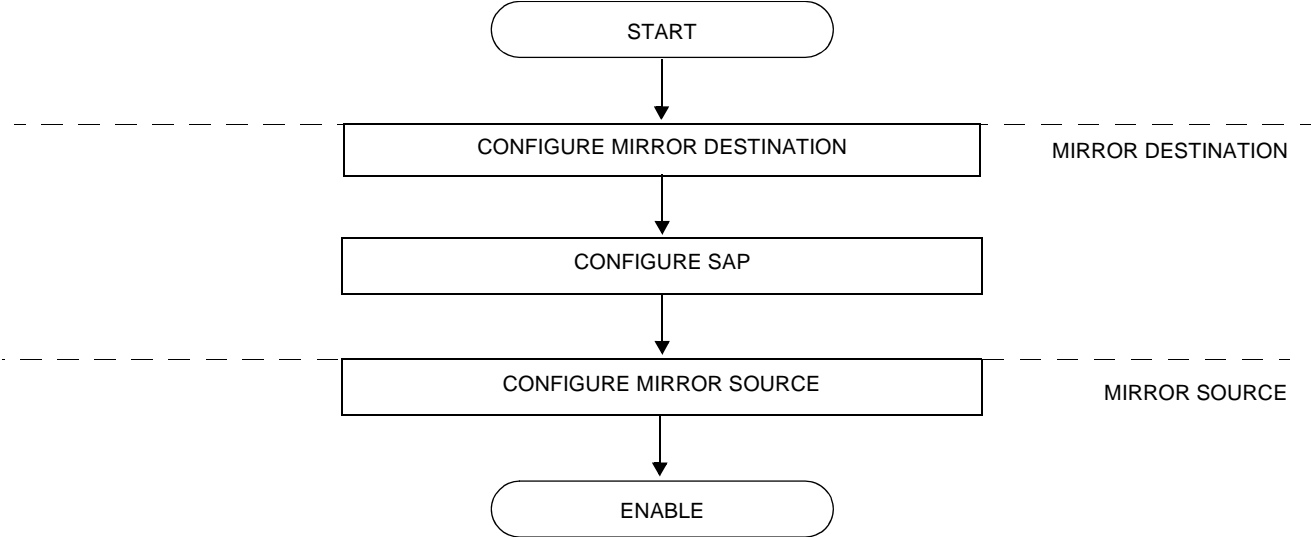

Figure 3: Mirror Configuration and Implementation Flow

## Configuration Notes

This section describes mirroring configuration caveats.

- Multiple mirroring service IDs (mirror destinations) may be created within a single system.
- A mirrored source can only have one destination.
- On 7210 SAS-E, before using a Dot1q SAP or Q1.\* SAP as a mirror destination, the user must configure a port for use with this feature using the command `config> system> loopback-no-svc-port mirror`. The user has an option to use either one of the available virtual internal port resources or a front panel port. The virtual internal port resources available can be determined using the command `show system internal-loopback-ports detail`. No services can be configured on this port. More details of both the commands can be found in the 7210 SAS Interfaces Configuration Guide.
- On 7210 SAS-D and 7210 SAS-E, in case of port egress mirroring, one egress mirror source can be configured to only one mirror destination. In other words, with port egress mirroring multiple ports configured as mirror sources cannot use the same mirror destination.
- On 7210 SAS-D, the software uses the resources associated with an internal port for mirror application.
- The destination mirroring service IDs and service parameters are persistent between router (re)boots and are included in the configuration saves.

Mirror source criteria configuration (defined in `debug>mirror>mirror-source`) is not preserved in a configuration save (admin save). Debug mirror source configuration can be saved using `admin>debug-save`.

- Physical layer problems such as collisions, jabbers, etc., are not mirrored. Typically, only complete packets are mirrored.
- Starting and shutting down mirroring:

Mirror destinations:

- The default state for a mirror destination service ID is shutdown. You must issue a **no shutdown** command to enable the feature.
- When a mirror destination service ID is shutdown, mirrored packets associated with the service ID are not accepted from its mirror source. The associated mirror source is put into an operationally down mode. Mirrored packets are not transmitted out the SAP. Each mirrored packet is silently discarded.
- Issuing the `shutdown` command causes the mirror destination service or its mirror source to be put into an administratively down state. Mirror destination service IDs must be shut down first in order to delete a service ID, or SAP association from the system.

### Mirror sources:

- The default state for a mirror source for a given mirror-dest service ID is no shutdown. Enter a `shutdown` command to deactivate (disable) mirroring from that mirror-source.
- Mirror sources do not need to be shutdown to remove them from the system. When a mirror source is shutdown, mirroring is terminated for all sources defined locally for the mirror destination service ID.

## Configuring Service Mirroring with CLI

This section provides information about service mirroring

Topics in this section include:

- [Mirror Configuration Overview on page 24](#)
- [Basic Mirroring Configuration on page 26](#)
  - [Mirror Classification Rules on page 27](#)
- [Common Configuration Tasks on page 29](#)
  - [Configuring a Local Mirror Service on page 30](#)
- [Service Management Tasks on page 32](#)
  - [Modifying a Local Mirrored Service on page 33](#)
  - [Deleting a Local Mirrored Service on page 34](#)

## Mirror Configuration Overview

7210 SAS node mirroring can be organized in the following logical entities:

- The mirror source is defined as the location from where the traffic should be mirrored. A mirror source could be ingress of service entity or egress of a service entity. The list of mirror sources supported on a given platform is listed above [Mirror Source Port Requirements on page 27](#)
  - A SAP is defined in local mirror services as the mirror destination to where the mirrored packets are sent.
- 

### Defining Mirrored Traffic

In some scenarios, or when multiple services are configured on the same port, specifying the port does not provide sufficient resolution to separate traffic. In Alcatel-Lucent's implementation of mirroring, multiple source mirroring parameters can be specified to further identify traffic.

Mirroring of packets matching specific filter entries in an IP or MAC filter can be applied to refine what traffic is mirrored to flows of traffic within a service. The IP criteria can be combinations of:

- Source IP address/mask
- Destination IP address/mask
- IP Protocol value
- Source port value (for example, UDP or TCP port)
- Destination port value (for example, UDP or TCP port)
- DiffServ Code Point (DSCP) value
- ICMP code
- ICMP type
- IP fragments
- TCP ACK set/reset
- TCP SYN set/reset

The MAC criteria can be combinations of:

- IEEE 802.1p value/mask
- Source MAC address/mask
- Destination MAC address/mask
- Ethernet Type II Ethernet type value

---

**NOTE:** The list of packet fields that are available to match packets in IP and MAC ACLs for different platforms is different. For more information on the lists of packet fields available on different platforms, see the “7210 SAS Router Configuration User Guide”.

---

## Basic Mirroring Configuration

Destination mirroring parameters must include at least:

- A mirror destination ID (same as the mirror source service ID).
- A mirror destination SAP.

Mirror source parameters must include at least:

- A mirror service ID (same as the mirror destination service ID).
- At least one source type (port, SAP, IP filter or MAC filter) specified.

The following example displays a sample configuration of a local mirrored service (ALA-A).

```
*A:ALA-A>config>mirror# info
-----
      mirror-dest 103 create
          exit
          no shutdown
      exit
-----
*A:ALA-A>config>mirror#
```

The following displays the mirror source configuration:

```
*A:ALA-A>debug>mirror-source# show debug mirror
debug
      mirror-source 103
          no shutdown
      exit
exit
*A:ALA-A>debug>mirror-source# exit
```

## Mirror Classification Rules

Alcatel-Lucent's implementation of mirroring can be performed by configuring parameters to select network traffic according to any of the following entities:

- [Port](#)
- [SAP](#)
- [MAC filter](#)
- [IP filter](#)

### Port

The `port` command associates a port to a mirror source. The port is identified by the port ID. The defined port can be Ethernet or a Link Aggregation Group (LAG) ID. When a LAG ID is given as the port ID, mirroring is enabled on all ports making up the LAG.

Mirror sources can be ports in either access or access uplink mode. Port mirroring is supported in the following combinations:

**Table 4: Mirror Source Port Requirements**

Port Type	Port Mode	Port Encap Type
faste/gige/10gige	access	null, dot1q and QinQ
faste/gige/10gige	access uplink	qinq

**CLI Syntax:** `debug>mirror-source# port {port-id|lag lag-id} {[egress] [ingress]}`

**Example:** `*A:ALA-A>debug>mirror-source# port 1/1/2 ingress egress`

### SAP

More than one SAP can be associated within a single mirror-source. Each SAP has its own ingress parameter keyword to define which packets are mirrored to the mirror-dest service ID. A SAP that is defined within a mirror destination cannot be used in a mirror source.

**CLI Syntax:** `debug>mirror-source# sap sap-id {[ingress]}` (For 7210 SAS-D/E)

**Example:** `*A:ALA-A>debug>mirror-source# sap 1/1/4:100 ingress`

**CLI Syntax:** For 7210 SAS-K : `debug>mirror-source# sap sap-id {[ingress] [egress]}`

## Basic Mirroring Configuration

**Example:** \*A:ALA-A>debug>mirror-source# sap 1/1/4:100 ingress

### MAC filter

MAC filters are configured in the **config>filter>mac-filter** context. The **mac-filter** command causes all the packets matching the explicitly defined list of entry IDs to be mirrored to the mirror destination specified by the service-id of the mirror source.

**CLI Syntax:** debug>mirror-source# mac-filter *mac-filter-id* entry *entry-id* [*entry-id* ...]

**Example:** \*A:ALA-2>debug>mirror-source# mac-filter 12 entry 15 20 25

---

### IP filter

IP filters are configured in the **config>filter>ip-filter** context. The **ip-filter** command causes all the packets matching the explicitly defined list of entry IDs to be mirrored to the mirror destination specified by the service-id of the mirror source.

Ingress mirrored packets are mirrored to the mirror destination prior to any ingress packet modifications.

**CLI Syntax:** debug>mirror-source# ip-filter *ip-filter-id* entry *entry-id* [*entry-id* ...]

**Example:** \*A:ALA-A>debug>mirror-source# ip-filter 1 entry 20

**NOTE:** An IP filter cannot be applied to a mirror destination SAP.

## Common Configuration Tasks

This section provides a brief overview of the tasks that must be performed to configure local mirror services and provides CLI command syntax. Note that the local mirror source and mirror destination components must be configured under the same service ID context.

Each local mirrored service (Figure 4) (within the same router) requires the following configurations:

1. Specify mirror destination (SAP).
2. Specify mirror source (port, SAP, IP filter, MAC filter).

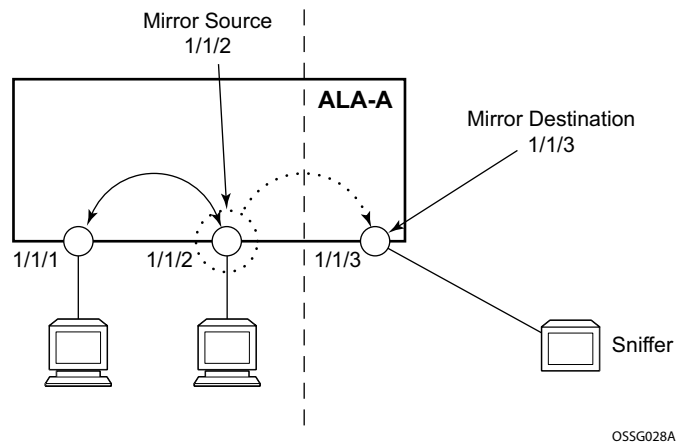

Figure 4: Local Mirrored Service Tasks

## Configuring a Local Mirror Service

To configure a local mirror service, the source and destinations must be located on the same router. Note that local mirror source and mirror destination components must be configured under the same service ID context.

The **mirror-source** commands are used as traffic selection criteria to identify traffic to be mirrored at the source. Each of these criteria are independent. For example, use the **debug>mirror-source>port** *{port-id | lag lag-id}* *{[egress] [ingress]}* command and **debug>mirror-source ip-filter** *ip-filter-id entry entry-id [entry-id...]* command to capture (mirror) traffic that matches a specific IP filter entry and traffic ingressing and egressing a specific port. A filter must be applied to the SAP or interface if only specific packets are to be mirrored.

Use the CLI syntax to configure one or more mirror source parameters:

The **mirror-dest** commands are used to specify where the mirrored traffic is to be sent. Use the following CLI syntax to configure mirror destination parameters:

**CLI Syntax:** `config>mirror mirror-dest service-id [type {ether}] [create] description string sap sap-id [create] no shutdown`

**CLI Syntax:** `debug# mirror-source service-id ip-filter ip-filter-id entry entry-id [entry-id ...] mac-filter mac-filter-id entry entry-id [entry-id ...] port {port-id|lag lag-id} {[egress] [ingress]} sap sap-id {[ingress]} no shutdown`

The following output displays an example of a local mirrored service using a NULL SAP. On ALA-A, mirror service 103 is mirroring traffic matching IP filter 2, entry 1 as well as egress and ingress traffic on port 1/1/23 and sending the mirrored packets to SAP 1/1/24

```
*A:ALA-A>config>mirror# info
-----
mirror-dest 103 create
  sap 1/1/24 create
  exit
  no shutdown
exit
-----
*A:ALA-A>config>mirror#
```

The following output displays an example of local mirrored service using a dot1q SAP. User needs to configure a front-panel port for use with the mirroring application when the mirror destination is a Dot1q SAP or a Q1.\* SAP, as shown below.

**NOTES:**

- On 7210 SAS-D, the loopback-no-svc-port is not needed. The software uses the resources associated with an internal port for mirroring application.
- On 7210 SAS-K, the loopbck-no-svc-port configuration is not needed.

```
*A:ALA-A>config>system>
-----
      loopback-no-svc-port mirror 1/1/14
-----

*A:ALA-A>config>mirror# info
-----
      mirror-dest 103 create
          sap 1/1/10:100 create
          exit
          no shutdown
      exit
-----

*A:ALA-A>config>mirror#
```

The following displays the debug mirroring information:

```
*A:ALA-A>debug>mirror-source# show debug mirror
debug
      mirror-source 103
          no shutdown
          port 1/1/23 ingress
          ip-filter 2 entry 1
      exit
exit
*A:ALA-A>debug>mirror-source# exit
```

The source and destination are configured on different routers for remote mirroring

```
[create] [type <mirror-type>] [mirror-source-type <mirror-source-
type>] [profile <profile>]
```

## Service Management Tasks

This section discusses the following service management tasks:

- [Modifying a Local Mirrored Service on page 33](#)
- [Deleting a Local Mirrored Service on page 34](#)

Use the following command syntax to modify an existing mirrored service:

**CLI Syntax:** config>mirror#  
mirror-dest *service-id* [type {ether}]  
description *description-string*  
no description  
sap *sap-id*  
no sap  
[no] shutdown

**CLI Syntax:** debug  
[no] mirror-source *service-id*  
ip-filter *ip-filter-id* entry *entry-id* [*entry-id...*]  
no ip-filter *ip-filter-id*  
no ip-filter entry *entry-id* [*entry-id...*]  
mac-filter *mac-filter-id* entry *entry-id* [*entry-id...*]  
no mac-filter *mac-filter-id*  
no mac-filter *mac-filter-id* entry *entry-id* [*entry-id...*]  
[no] port {*port-id*|lag *lag-id*} {[egress][ingress]}  
[no] sap *sap-id* {[ingress]}  
[no] shutdown

## Modifying a Local Mirrored Service

Existing mirroring parameters can be modified in the CLI. The changes are applied immediately. The service must be shut down if changes to the SAP are made.

The following example displays commands to modify parameters for a basic local mirroring service.

```
Example: config>mirror# mirror-dest 103
config>mirror>mirror-dest# shutdown
config>mirror>mirror-dest# no sap
config>mirror>mirror-dest# sap 1/1/5 create
config>mirror>mirror-dest>sap$ exit
config>mirror>mirror-dest# no shutdown
debug# mirror-source 103
debug>mirror-source# no port 1/1/23
debug>mirror-source# port 1/1/7 ingress egress
```

The following displays the local mirrored service modifications:

```
*A:ALA-A>config>mirror# info
-----
mirror-dest 103 create
          no shutdown
          sap 1/1/5 create
          exit

*A:ALA-A>debug>mirror-source# show debug mirror
debug
  mirror-source 103
    no shutdown
    port 1/1/7 egress ingress
  exit
*A:ALA-A>debug>mirror-source#
```

## Deleting a Local Mirrored Service

Existing mirroring parameters can be deleted in the CLI. A shutdown must be issued on a service level in order to delete the service. It is not necessary to shut down or remove SAP or port references to delete a local mirrored service.

The following example displays commands to delete a local mirrored service.

```
Example:ALA-A>config>mirror# mirror-dest 103
config>mirror>mirror-dest# shutdown
config>mirror>mirror-dest# exit
config>mirror# no mirror-dest 103
config>mirror# exit
```





---

## Mirror Service Command Reference

---

- [Mirror Configuration Commands for 7210 SAS-E and D devices on page 38](#)
- [Mirror Configuration Commands for 7210 SAS-K devices on page 38](#)
- [Show Commands on page 39](#)
- [Debug Commands on page 39](#)

## Mirror Configuration Commands for 7210 SAS-E and D devices

```
config
  — mirror
    — mirror-dest service-id [type encap-type] [create]
    — no mirror-dest service-id
      — description description-string
      — no description
      — [no] fc [fc-name] [profile profile]
      — [no] sap sap-id [create]
      — [no] service-name service-name
      — [no] shutdown
```

## Mirror Configuration Commands for 7210 SAS-K devices

```
config
  — mirror
    — mirror-dest service-id [type encap-type] [create]
    — no mirror-dest service-id
      — description description-string
      — no description
      — [no] fc [fc-name] [profile profile]
      — [no] sap sap-id [create]
        — [no] egress
          — [no] qos policy-id
      — service-name service-name
      — [no] service-name
      — [no] shutdown
```

## Show Commands

```
show
  — debug [application]
  — mirror mirror-dest [service-id]
  — service
     — service-using mirror
```

## Debug Commands

```
debug
  — [no] mirror-source service-id
     — [no] ip-filter ip-filter-id [entry entry-id]
     — [no] mac-filter mac-filter-id [entry entry-id...]
     — [no] port {port-id | lag lag-id} [egress] [ingress]
     — [no] sap sap-id {[ingress] [egress]}
     — [no] shutdown
```



---

## Configuration Commands

---

### Generic Commands

#### description

**Syntax** **description** *description-string*  
**no description**

**Context** config>mirror>mirror-dest

**Description** This command creates a text description stored in the configuration file for a configuration context to help the administrator identify the content of the file.

The **no** form of the command removes the description string.

**Default** There is no default description associated with the configuration context.

**Parameters** *description-string* — The description character string. Allowed values are any string up to 80 characters long composed of printable, 7-bit ASCII characters. If the string contains special characters (#, \$, spaces, etc.), the entire string must be enclosed within double quotes.

#### shutdown

**Syntax** [**no**] **shutdown**

**Context** config>mirror>mirror-dest  
debug>mirror-source

**Description** The **shutdown** command administratively disables an entity. When disabled, an entity does not change, reset, or remove any configuration settings or statistics. Many entities must be explicitly enabled using the **no shutdown** command.

The **shutdown** command administratively disables an entity. The operational state of the entity is disabled as well as the operational state of any entities contained within. Many objects must be shut down before they may be deleted.

Unlike other commands and parameters where the default state is not indicated in the configuration file, **shutdown** and **no shutdown** are always indicated in system generated configuration files.

The **no** form of the command puts an entity into the administratively enabled state.

**Default** See Special Cases below.

**Special Cases** **Mirror Destination** — When a mirror destination service ID is shutdown, mirrored packets associated with the service ID are not accepted from the mirror source device. The associated mirror source is put into an operationally down mode. Mirrored packets are not transmitted out of the SAP. Each mirrored packet is silently discarded. If the mirror destination is a SAP, the SAP's discard counters are increased.

## Configuration Commands

The **shutdown** command places the mirror destination service or mirror source into an administratively down state. The **mirror-dest** service ID must be shut down in order to delete the service ID, SAP association from the system.

The default state for a mirror destination service ID is **shutdown**. A **no shutdown** command is required to enable the service.

**Mirror Source** — Mirror sources do not need to be shutdown in order to remove them from the system.

When a mirror source is **shutdown**, mirroring is terminated for all sources defined locally for the **mirror-dest** service ID.

The default state for a mirror source for a given **mirror-dest** service ID is **no shutdown**. A **shutdown** command is required to disable mirroring from that mirror-source.

## Mirror Destination Configuration Commands

### mirror-dest

**Syntax** **mirror-dest** *service-id* [**type** *encap-type*] [**mirror-source-type** *mirror-source-type*][create]  
**no mirror-dest**

**Context** config>mirror

**Description** This command creates a context to set up a service that is intended for packet mirroring. It is configured as a service to allow mirrored packets to be directed locally (within the same device), over the core of the network and have a far end device decode the mirror encapsulation.

The **mirror-dest** service is comprised of destination parameters that define where the mirrored packets are to be sent. It also specifies whether the defined *service-id* will receive mirrored packets from far end devices over the network core.

The **mirror-dest** service IDs are persistent between boots of the router and are included in the configuration backups. The local sources of mirrored packets for the service ID are defined within the **debug mirror mirror-source** command that references the same *service-id*.

The **mirror-dest** command is used to create or edit a service ID for mirroring purposes. If the *service-id* does not exist within the context of all defined services, the **mirror-dest** service is created and the context of the CLI is changed to that service ID. If the *service-id* exists within the context of defined **mirror-dest** services, the CLI context is changed for editing parameters on that service ID. If the *service-id* exists within the context of another service type, an error message is returned and CLI context is not changed from the current context.

The **no** form of the command removes a mirror destination from the system. The **mirror-source** associations with the **mirror-dest** *service-id* do not need to be removed or shutdown first. The **mirror-dest** *service-id* must be shutdown before the service ID can be removed. When the service ID is removed, all **mirror-source** commands that have the service ID defined will also be removed from the system.

**Default** No packet mirroring services are defined.

**Parameters** *service-id* — The service id identifies the service in the service domain. This ID is unique to this service and cannot be used by any other service, regardless of service type. The same service ID must be configured on every device that this particular service is defined on.

If a particular service ID already exists for a service, then the same value cannot be used to create a mirror destination service ID with the same value.

For example:

If an Epipe service-ID **11** exists, then a mirror destination service-ID **11** cannot be created. If a VPLS service-ID **12** exists, then a mirror destination service-ID **12** cannot be created.

If an IES service-ID **13** exists, then a mirror destination service-ID **13** cannot be created.

**Values** *service-id:* 1 — 2147483647

## Configuration Commands

**type** *encap-type* — The type describes the encapsulation supported by the mirror service.

**Values** ether

### fc

**Syntax** **fc fc-name**  
**no fc**

**Context** config>mirror>mirror-dest

**Description** This command specifies a forwarding class for all mirrored copy of the packets transmitted to the destination SAP overriding the default (be) forwarding class. All packets are sent with the same class of service to minimize out of sequence issues. The mirrored copy of the packet does not inherit the forwarding class of the original packet.

When the destination is on a SAP, it pulls buffers from the queue associated with the fc-name and the shaping and scheduling treatment given to the packet is as per the user configuration for that queue.

On 7210 SAS-D and 7210 SAS-E, all SAPs configured on a port use the port-based egress queues. If the mirror destination SAP (that is, dot1q SAP or a Q1.\* SAP) is configured to share an uplink with service traffic, mirrored copy of the traffic sent out of the Dot1q or Q1.\* SAP will share the port-based egress queues with the other service traffic. User is provided an option to assign the profile mirrored to the mirrored copy of the packets, so that during congestion mirrored copy of the packets marked as out-of-profile is dropped before in-profile service traffic (and possibly in-profile mirrored traffic, if user has configured mirrored traffic to be in-profile). The profile is used to determine the slope policy to use for the packet and determines the packet's drop precedence. Additionally, if marking is enabled, it determines the marking value to be used in the packet header.

On 7210 SAS-K, the following QoS functionality is available for mirror destination:

- If the mirror destination is a SAP on a access-uplink port, it uses port-based egress queues which is shared by all the SAPs configured on the port. In other words, if the mirror destination SAP is configured to share an access-uplink port with service traffic, mirrored copy of the traffic sent out of the port will share the port-based egress queues with other service traffic. The user is provided an option to assign the profile to the mirrored copy of the packets, so that during congestion mirrored copy of the packets marked as out-of-profile is dropped before in-profile service traffic. The profile is used to determine the slope policy to use for the packet and determines the packet's drop precedence. Additionally, if marking is enabled, it determines the marking value to be used in the packet header.
- If the mirror destination is a SAP on an access port, it uses per SAP egress queues. In this case, a SAP is dedicated for use as a mirror destination. The user is provided an option to assign the profile to the mirrored copy of the packets, so that during congestion mirrored copy of the packets marked as out-of-profile is dropped before in-profile traffic. The profile is used to determine the slope policy to use for the packet and determines the packet's drop precedence. Additionally, if marking is enabled, it determines the marking value to be used in the packet header.

The no form of the command returns the mirror-dest service ID forwarding class to the default forwarding class.

**Default** The best effort (be) forwarding class is associated with the mirror-dest service ID and profile is out.

**Parameters** *fc-name* — The name of the forwarding class with which to associate mirrored service traffic. The forwarding class name must already be defined within the system. If the *fc-name* does not exist, an error will be returned and the *fc* command will have no effect. If the *fc-name* does exist, the forwarding class associated with *fc-name* will override the default forwarding class.

**Values** be, l2, af, l1, h2, ef, h1, nc

*profile* — The profile to assign to mirrored copy of the service traffic. The profile is used to determine the slope policy to use for the packet and determines the packet's drop precedence. Additionally, if marking is enabled, it determines the marking value to be used in the packet header. A value of *in* marks the traffic as in-profile traffic and results in use of high slope parameters. A value of *out* marks the traffic as out-of-profile and results in use of low slope parameters.

**Values** in, out

**Default** out

## sap

**Syntax** **sap** *sap-id* [**create**]  
**no sap**

**Context** config>mirror>mirror-dest

**Description** This command creates a service access point (SAP) within a mirror destination service. The SAP is owned by the mirror destination service ID.

The SAP is defined with port and encapsulation parameters to uniquely identify the (mirror) SAP on the interface and within the box. The specified SAP must define an Ethernet port with a null SAP or a Dot1q SAP or a Q1.\* SAP.

### NOTES:

- Before using a Dot1q SAP or a Q1.\* SAP, the user needs to dedicate a port for use with mirroring application using the command “*config> system> loopback-no-svc-port*”. This is required only for 7210 SAS-E. For more information about this command, see the “7210 SAS Interfaces Configuration Guide”.
- On 7210 SAS-D and 7210 SAS-E, a Q1.Q2 SAP cannot be used as a mirror destination SAP when the access port encapsulation is set to QinQ or on an access-uplink port.

Only one SAP can be created within a **mirror-dest** service ID. If the defined SAP has not been created on any service within the system, the SAP is created and the context of the CLI will change to the newly created SAP. In addition, the port cannot be a member of a multi-link bundle, LAG, APS group or IMA bundle.

If the defined SAP exists in the context of another service ID, **mirror-dest** or any other type, an error is generated.

Mirror destination SAPs can be created on Ethernet interfaces that have been defined as an access port or access-uplink port. If the interface is defined as network, the SAP creation returns an error.

## Configuration Commands

**NOTE:** When using a dot1q SAP or a Q1.\* SAP as a mirror destination, users must allocated resources of another port for use by this features. Please refer the mirror configuration notes above [Configuration Notes on page 21](#).

When the **no** form of this command is used on a SAP created by a mirror destination service ID, the SAP with the specified port and encapsulation parameters is deleted.

**Default** No default SAP for the mirror destination service defined.

**Parameters** *sap-id* — Specifies the physical port identifier portion of the SAP definition. See [Common CLI Command Descriptions on page 223](#) for command syntax.

### service-name

**Syntax** **service-name** *service-name*  
**no service-name**

**Context** config>mirror>mirror-dest

**Description** This command configures an optional service name, up to 64 characters in length, which adds a name identifier to a given service to then use that service name in configuration references as well as display and use service names in show commands throughout the system. This helps the service provider/administrator to identify and manage services within the 7210 SAS platforms.

All services are required to assign a service ID to initially create a service. However, either the service ID or the service name can be used to identify and reference a given service once it is initially created.

**Parameters** *service-name* — Specifies a unique service name to identify the service. Service names may not begin with an integer (0-9).

### egress

**Syntax** **egress**

**Context** config> mirror> sap

**Description** This command provides the context to configure QoS egress policies for this SAP.

### qos

**Syntax** [**no**] **qos** *policy-id*

**Context** config> mirror> sap> egress

**Description** This command allows user to configure the QoS policy for the mirror destination SAP egress. The SAP egress QoS policy to use is specified using the *policy-id*> and must have been configured before associating this policy with the SAP. The SAP egress policy can be configured using the commands under the context config> qos> sap-egress.

When a SAP egress policy is associated with the SAP configured as a mirror destination, the queue associated with FC specified with the CLI command `config> mirror> mirror-dest> fc`, is used for traffic sent out of the mirror destination SAP. The policy allows the user to specify the amount of buffers, the WRED policy, the shaping rate and the marking values to use for the mirrored copy.

The `no` form of the command associates the default SAP egress QoS policy with the SAP.

**Default**    `no qos`

**Parameters**    *policy-id* — Specifies the QoS policy to associated with SAP egress. The QoS policy referred to by the *policy-id* is configured using the commands under `config> qos> sap-egress`.



---

## Mirror Source Configuration Commands

### mirror-source

**Syntax** [no] **mirror-source** *service-id*

**Context** debug

**Description** This command configures mirror source parameters for a mirrored service.

The **mirror-source** command is used to enable mirroring of packets specified by the association of the **mirror-source** to sources of packets defined within the context of the *mirror-dest-service-id*. The mirror destination service must already exist within the system.

A mirrored packet cannot be mirrored to multiple destinations. If a mirrored packet is properly referenced by multiple mirror sources (for example, a SAP on one **mirror-source** and a port on another **mirror-source**), then the packet is mirrored to a single *mirror-dest-service-id* based on the following hierarchy:

1. Filter entry
2. Service access port (SAP)
3. Physical port

The hierarchy is structured so the most specific match criteria has precedence over a less specific match. For example, if a **mirror-source** defines a port and a SAP on that port, then the SAP mirror-source is accepted and the mirror-source for the port is ignored because of the hierarchical order of precedence.

The **mirror-source** configuration is not saved when a configuration is saved. A **mirror-source** manually configured within an ASCII configuration file will not be preserved if that file is overwritten by a **save** command. Define the **mirror-source** within a file associated with a **config exec** command to make a **mirror-source** persistent between system reboots.

By default, all **mirror-dest** service IDs have a **mirror-source** associated with them. The **mirror-source** is not technically created with this command. Instead the service ID provides a contextual node for storing the current mirroring sources for the associated **mirror-dest** service ID. The **mirror-source** is created for the mirror service when the operator enters the **debug>mirror-source** *svcId* for the first time. The **mirror-source** is also automatically removed when the **mirror-dest** service ID is deleted from the system.

The **no** form of the command deletes all related source commands within the context of the **mirror-source** *service-id*. The command does not remove the service ID from the system.

**Default** No mirror source match criteria is defined for the mirror destination service.

**Parameters** *service-id* — The mirror destination service ID for which match criteria will be defined. The *service-id* must already exist within the system.

**Values** *service-id:* 1 — 2147483647

### ip-filter

**Syntax** **ip-filter** *ip-filter-id* **entry** *entry-id* [*entry-id* ...]  
**no ip-filter** *ip-filter-id*  
**no ip-filter** *ip-filter-id* **entry** *entry-id* [*entry-id* ...]

**Context** debug>mirror-source

**Description** This command enables mirroring of packets that match specific entries in an existing IP filter.

The **ip-filter** command directs packets which match the defined list of entry IDs to be mirrored to the mirror destination referenced by the *mirror-dest-service-id* of the **mirror-source**.

The IP filter must already exist in order for the command to execute. Filters are configured in the **config>filter** context. If the IP filter does not exist, an error will occur. If the filter exists but has not been associated with a SAP or IP interface, an error is not generated but mirroring will not be enabled (there are no packets to mirror). Once the IP filter is defined to a SAP or IP interface, mirroring is enabled.

If the IP filter is defined as ingress, only ingress packets are mirrored. Ingress mirrored packets are mirrored to the mirror destination prior to any ingress packet modifications.

If the IP filter is defined as egress, only egress packets are mirrored. Egress mirrored packets are mirrored to the mirror destination after all egress packet modifications.

An *entry-id* within an IP filter can only be mirrored to a single mirror destination. If the same *entry-id* is defined multiple times, an error occurs and only the first **mirror-source** definition is in effect.

By default, no packets matching any IP filters are mirrored. Mirroring of IP filter entries must be explicitly defined.

The **no ip-filter** command, without the **entry** keyword, removes mirroring on all *entry-id*'s within the *ip-filter-id*.

When the **no** command is executed with the **entry** keyword and one or more *entry-id*'s, mirroring of that list of *entry-id*'s is terminated within the *ip-filter-id*. If an *entry-id* is listed that does not exist, an error will occur and the command will not execute. If an *entry-id* is listed that is not currently being mirrored, no error will occur for that *entry-id* and the command will execute normally.

**Default** IP filter mirroring is not defined.

**Parameters** *ip-filter-id* — The IP filter ID whose entries are mirrored. If the *ip-filter-id* does not exist, an error will occur and the command will not execute. Mirroring of packets will commence once the *ip-filter-id* is defined on a SAP or IP interface.

**entry** *entry-id* [*entry-id* ...] — The IP filter entries to use as match criteria for packet mirroring. The **entry** keyword begins a list of *entry-id*'s for mirroring. Multiple *entry-id* entries may be specified with a single command. Each *entry-id* must be separated by a space.

If an *entry-id* does not exist within the IP filter, an error occurs and the command will not execute.

If the filter's *entry-id* is renumbered within the IP filter definition, the old *entry-id* is removed but the new *entry-id* must be manually added to the configuration to include the new (renumbered) entry's criteria.

## mac-filter

**Syntax** **mac-filter** *mac-filter-id* **entry** *entry-id* [*entry-id* ...]  
**no mac-filter** *mac-filter-id*  
**no mac-filter** *mac-filter-id* **entry** *entry-id* [*entry-id* ...]

**Context** debug>mirror-source

**Description** This command enables mirroring of packets that match specific entries in an existing MAC filter.

The **mac-filter** command directs packets which match the defined list of entry IDs to be mirrored to the mirror destination referenced by the *mirror-dest-service-id* of the **mirror-source**.

The MAC filter must already exist in order for the command to execute. Filters are configured in the `config>filter` context. If the MAC filter does not exist, an error will occur. If the filter exists but has not been associated with a SAP or IP interface, an error is not be generated but mirroring will not be enabled (there are no packets to mirror). Once the filter is defined to a SAP or MAC interface, mirroring is enabled.

If the MAC filter is defined as ingress, only ingress packets are mirrored. Ingress mirrored packets are mirrored to the mirror destination prior to any ingress packet modifications.

The **no mac-filter** command, without the **entry** keyword, removes mirroring on all *entry-id*'s within the *mac-filter-id*.

When the **no** command is executed with the **entry** keyword and one or more *entry-id*'s, mirroring of that list of *entry-id*'s is terminated within the *mac-filter-id*. If an *entry-id* is listed that does not exist, an error will occur and the command will not execute. If an *entry-id* is listed that is not currently being mirrored, no error will occur for that *entry-id* and the command will execute normally.

**Default** No MAC filter mirroring defined.

**Parameters** *mac-filter-id* — The MAC filter ID whose entries are mirrored. If the *mac-filter-id* does not exist, an error will occur and the command will not execute. Mirroring of packets will commence once the *mac-filter-id* is defined on a SAP.

**entry** *entry-id* [*entry-id* ...] — The MAC filter entries to use as match criteria for packet mirroring. The **entry** keyword begins a list of *entry-id*'s for mirroring. Multiple *entry-id* entries may be specified with a single command. Each *entry-id* must be separated by a space. Up to 8 entry IDs may be specified in a single command.

Each *entry-id* must exist within the *mac-filter-id*. If the *entry-id* is renumbered within the MAC filter definition, the old *entry-id* is removed from the list and the new *entry-id* will need to be manually added to the list if mirroring is still desired.

If no *entry-id* entries are specified in the command, mirroring will not occur for that MAC filter ID. The command will have no effect.

## Configuration Commands

### port

**Syntax** **port** {*port-id* | **lag** *lag-id*} {[**egress**] [**ingress**]}  
**no port** {*port-id* | **lag** *lag-id*} [**egress**] [**ingress**]

**Context** debug>mirror-source

**Description** This command enables mirroring of traffic ingressing or egressing a port (Ethernet port, or Link Aggregation Group (LAG)).

The **port** command associates a port or LAG to a mirror source. The port is identified by the *port-id*. The defined port may be Ethernet, access or access uplink. access. A port may be a single port or a Link Aggregation Group (LAG) ID. When a LAG ID is given as the *port-id*, mirroring is enabled on all ports making up the LAG. Either a LAG port member *or* the LAG port can be mirrored.

The port is only referenced in the mirror source for mirroring purposes. If the port is removed from the system, the mirroring association will be removed from the mirror source.

The same port may not be associated with multiple mirror source definitions with the **ingress** parameter defined. The same port may not be associated with multiple mirror source definitions with the **egress** parameter defined.

If a SAP is mirrored on an access port, the SAP mirroring will have precedence over the access port mirroring when a packet matches the SAP mirroring criteria. Filter and label mirroring destinations will also precedence over a port-mirroring destination.

If the port is not associated with a **mirror-source**, packets on that port will not be mirrored. Mirroring may still be defined for a SAP or filter entry, which will mirror based on a more specific criteria.

The **no port** command disables port mirroring for the specified port. Mirroring of packets on the port may continue due to more specific mirror criteria. If the **egress** or **ingress** parameter keywords are specified in the **no** command, only the ingress or egress mirroring condition will be removed.

**Default** No ports are defined.

**Parameters** *port-id* — Specifies the port ID.

**Values** SAS-D-[1..10]  
SAS-K-[1..5]

*lag-id* — The LAG identifier, expressed as a decimal integer.

**Values** SAS-D-[1..5]  
SAS-E-[1..6]  
SAS-K-[1..3]

**egress** — Specifies that packets egressing the port should be mirrored. Egress packets are mirrored to the mirror destination after egress packet modification.

**ingress** — Specifies that packets ingressing the port should be mirrored. Ingress packets are mirrored to the mirror destination prior to ingress packet modification.

## sap

**Syntax** **no sap** *sap-id* {[ingress] [egress]}  
**no sap** *sap-id* {[ingress] [egress]}

**Context** debug>mirror-source

**Description** This command enables mirroring of traffic ingressing a service access port (SAP). A SAP that is defined within a mirror destination cannot be used in a mirror source. The mirror source SAP referenced by the *sap-id* is owned by the service ID of the service in which it was created. The SAP is only referenced in the mirror source name for mirroring purposes. The mirror source association does not need to be removed before deleting the SAP from its service ID. If the SAP is deleted from its service ID, the mirror association is removed from the mirror source.

More than one SAP can be associated within a single **mirror-source**. Each SAP has its own **ingress** parameter keyword to define which packets are mirrored to the mirror destination.

The SAP must be valid and properly configured. If the associated SAP does not exist, an error occurs and the command will not execute.

The same SAP cannot be associated with multiple mirror source definitions for ingress packets. The same SAP cannot be associated with multiple mirror source definitions for egress packets.

If a particular SAP is not associated with a mirror source name, then that SAP will not have mirroring enabled for that mirror source.

The **no** form of the command disables mirroring for the specified SAP. All mirroring for that SAP on ingress is terminated. Mirroring of packets on the SAP can continue if more specific mirror criteria is configured. If the **ingress** parameter keyword are specified in the **no** command, only the ingress mirroring condition is removed.

**Default** No SAPs are defined by default.

**Parameters** *sap-id* — Specifies the physical port identifier portion of the SAP definition. See [Common CLI Command Descriptions on page 223](#) for command syntax.

**ingress** — Specifies that packets ingressing the SAP should be mirrored. Ingress packets are mirrored to the mirror destination prior to ingress packet modification.

**egress** — Supported only on **7210 SAS-K**. Specifies that packets egressing the SAP should be mirrored. Egress packets are mirrored to the mirror destination prior to egress packet modification.



---

## Show Commands

### debug

**Syntax** `debug [application]`

**Context** `show`

**Description** This command displays set debug points.

**Parameters** *application* — Display which debug points have been set.

**Values:** service, ip, ospf, mtrace, rip, isis, mpls, rsvp, ldp, mirror, system, filter, subscriber-mgmt, radius, lag, oam

**Output**

```
*A:alul# show debug
debug
  mirror-source 101
    port 1/1/1 ingress
    no shutdown
  exit
  mirror-source 102
    port 1/1/3 egress
    no shutdown
  exit
exit
*A:alul#
```

### service-using

**Syntax** `service-using [mirror]`

**Context** `show>service`

**Description** Displays mirror services.

If no optional parameters are specified, all services defined on the system are displayed.

**Parameters** **mirror** — Displays mirror services.

**Output** **Show Service-Using Mirror** — The following table describes service-using mirror output fields:

Label	Description
Service Id	The service identifier.
Type	Specifies the service type configured for the service ID.
Adm	The desired state of the service.
Opr	The operating state of the service.

Label	Description (Continued)
CustomerID	The ID of the customer who owns this service.
Last Mgmt Change	The date and time of the most recent management-initiated change to this service.

**Sample Output**

```
A:ALA-48# show service service-using mirror
=====
Services [mirror]
=====
ServiceId   Type      Adm   Opr      CustomerId  Last Mgmt Change
-----
218         Mirror   Up    Down     1            04/08/2007 13:49:57
318         Mirror   Down  Down     1            04/08/2007 13:49:57
319         Mirror   Up    Down     1            04/08/2007 13:49:57
320         Mirror   Up    Down     1            04/08/2007 13:49:57
1000        Mirror   Down  Down     1            04/08/2007 13:49:57
1216        Mirror   Up    Down     1            04/08/2007 13:49:57
1412412    Mirror   Down  Down     1            04/08/2007 13:49:57
-----
Matching Services : 7
=====
A:ALA-48#
```

## mirror

**Syntax** `mirror mirror-dest service-id`

**Context** show

**Description** This command displays mirror configuration and operation information.

**Parameters** *service-id* — Specify the mirror service ID.

**Values** [1..2147483648] svc-name:64 char max

**Output** **Mirroring Output** — The following table describes the mirroring output fields:

Label	Description
Service Id	The service ID associated with this mirror destination.
Type	Entries in this table have an implied storage type of “volatile”. The configured mirror source information is not persistent.
Admin State	Up — The mirror destination is administratively enabled. Down — The mirror destination is administratively disabled.
Oper State	Up — The mirror destination is operationally enabled. Down — The mirror destination is operationally disabled.
Forwarding Class	The forwarding class for all packets transmitted to the mirror destination.
Remote Sources	Yes — A remote source is configured. No — A remote source is not configured.
Slice	The value of the slice-size, is the maximum portion of the mirrored frame that will be transmitted to the mirror destination. Any frame larger than the slice-size will be truncated to this value before transmission to the mirror destination. A value of 0 indicates that mirrored packet truncation based on slice size is disabled.
Destination SAP	The ID of the access port where the Service Access Point (SAP) associated with this mirror destination service is defined.
Egr QoS Policy	This value indicates the egress QoS policy ID. A value of 0 indicates that no QoS policy is specified.

### Sample Output

```
*7210SAS# show mirror mirror-dest 1000
```

```
=====
```

Mirror Service

```
=====
Service Id      : 1000                Type           : Ether
Description     : (Not Specified)
Admin State     : Up                  Oper State      : Up
Forwarding Class : be                 Remote Sources  : No
Profile         : out
Slice           : 0
Destination SAP : 1/1/1:10.*         Egr QoS Policy: 1
=====
```

-----
Local Sources
-----

```
Admin State     : Up

-Port           1/1/4                Egr
-Port           1/1/7                Ing
-SAP            1/1/1:20.*           Ing
-IP Filter      1                    Entry 1
-MAC Filter     1                    Entry 1
```

# OAM and SAA

---

## In This Chapter

This chapter provides information about the Operations, Administration and Management (OAM) and Service Assurance Agent (SAA) commands available in the CLI for troubleshooting services.

Topics in this chapter include:

- [OAM Overview on page 60](#)
- [Ethernet Connectivity Fault Management \(ETH-CFM\) on page 62](#)
- [Synthetic Loss Measurement \(ETH-SL\) on page 78](#)
- [Service Assurance Agent Overview on page 83](#)  
→ [SAA Application on page 174](#)

## OAM Overview

Delivery of services requires a number of operations occur properly and at different levels in the service delivery model. For example, operations such as the association of packets to a service, must be performed properly in the forwarding plane for the service to function properly. In order to verify that a service is operational, a set of in-band, packet-based Operation, Administration, and Maintenance (OAM) tools is required, with the ability to test each of the individual packet operations.

For in-band testing, the OAM packets closely resemble customer packets to effectively test the customer's forwarding path, but they are distinguishable from customer packets so they are kept within the service provider's network and not forwarded to the customer.

- The suite of OAM diagnostics supplement the basic IP ping and traceroute operations with diagnostics specialized for the different levels in the service delivery model. There are diagnostics for services.

---

## Two-Way Active Measurement Protocol (TWAMP)

**Note:** This feature is not supported on 7210 SAS-K devices.

Two-Way Active Measurement Protocol (TWAMP) provides a standards-based method for measuring the round-trip IP performance (packet loss, delay and jitter) between two devices. TWAMP uses the methodology and architecture of One-Way Active Measurement Protocol (OWAMP) to define a way to measure two-way or round-trip metrics.

There are four logical entities in TWAMP:

- The control-client
- The session-sender
- The server
- The session-reflector.

The control-client and session-sender are typically implemented in one physical device (the “client”) and the server and session-reflector in a second physical device (the “server”) with which the two-way measurements are being performed. The 7210 SAS acts as the server. The control-client and server establishes a TCP connection and exchange TWAMP-Control messages over this connection. When the control-client requires to start testing, the client communicates the test parameters to the server. If the server corresponds to conduct the described tests, the test begins as soon as the client sends a Start-Sessions message. As part of a test, the sessionsender sends a stream of UDP-based test packets to the session-reflector, and the session reflector responds to each received packet with a response UDP-based test packet. When the session-sender receives the

response packets from the session-reflector, the information is used to calculate two-way delay, packet loss, and packet delay variation between the two devices.

## Configuration Notes

The following are the configuration notes:

- Unauthenticated mode is supported. Encrypted and Authenticated modes are not supported.
- TWAMP is supported only in the base router instance.
- By default, 7210 uses TCP port number 862 to listen for TWAMP control connections and this is not user configurable.

## Ethernet Connectivity Fault Management (ETH-CFM)

The IEEE and the ITU-T have cooperated to define the protocols, procedures and managed objects to support service based fault management. Both IEEE 802.1ag standard and the ITU-T Y.1731 recommendation support a common set of tools that allow operators to deploy the necessary administrative constructs, management entities and functionality, Ethernet Connectivity Fault Management (ETH-CFM). The ITU-T has also implemented a set of advanced ETH-CFM and performance management functions and features that build on the proactive and on demand troubleshooting tools.

CFM uses Ethernet frames and is distinguishable by ether-type 0x8902. In certain cases the different functions will use a reserved multicast address that could also be used to identify specific functions at the MAC layer. However, the multicast MAC addressing is not used for every function or in every case. The Operational Code (OpCode) in the common CFM header is used to identify the type of function carried in the CFM packet. CFM frames are only processed by IEEE MAC bridges. With CFM, interoperability can be achieved between different vendor equipment in the service provider network upto and including customer premises bridges. The following table lists CFM-related acronyms used in this section.

IEEE 802.1ag and ITU-T Y.1731 functions that are implemented are available on the 7210 SAS platforms.

Acronym	Callout
1DM	One way Delay Measurement (Y.1731)
AIS	Alarm Indication Signal
CCM	Continuity check message
CFM	Connectivity fault management
DMM	Delay Measurement Message (Y.1731)
DMR	Delay Measurement Reply (Y.1731)
LBM	Loopback message
LBR	Loopback reply
LTM	Linktrace message
LTR	Linktrace reply
ME	Maintenance entity
MA	Maintenance association

<b>Acronym</b>	<b>Callout (Continued)</b>
MA-ID	Maintenance association identifier
MD	Maintenance domain
MEP	Maintenance association end point
MEP-ID	Maintenance association end point identifier
MHF	MIP half function
MIP	Maintenance domain intermediate point
OpCode	Operational Code
RDI	Remote Defect Indication
TST	Ethernet Test (Y.1731)

## ETH-CFM Building Blocks

The IEEE and the ITU-T use their own nomenclature when describing administrative contexts and functions. This introduces a level of complexity to configuration, discussion and different vendors naming conventions. The 7210 SAS OS CLI has chosen to standardize on the IEEE 802.1ag naming where overlap exists. ITU-T naming is used when no equivalent is available in the IEEE standard. In the following definitions, both the IEEE name and ITU-T names are provided for completeness, using the format IEEE Name/ITU-T Name.

Maintenance Domain (MD)/Maintenance Entity (ME) is the administrative container that defines the scope, reach and boundary for faults. It is typically the area of ownership and management responsibility. The IEEE allows for various formats to name the domain, allowing upto 45 characters, depending on the format selected. ITU-T supports only a format of “none” and does not accept the IEEE naming conventions.

0 — Undefined and reserved by the IEEE.

1 — No domain name. It is the only format supported by Y.1731 as the ITU-T specification does not use the domain name. This is supported in the IEEE 802.1ag standard but not in currently implemented for 802.1ag defined contexts.

2,3,4 — Provides the ability to input various different textual formats, upto 45 characters. The string format (2) is the default and therefore the keyword is not shown when looking at the configuration.

Maintenance Association (MA)/Maintenance Entity Group (MEG) is the construct where the different management entities will be contained. Each MA is uniquely identified by its MA-ID. The MA-ID is comprised of the by the MD level and MA name and associated format. This is another administrative context where the linkage is made between the domain and the service using the **bridging-identifier** configuration option. The IEEE and the ITU-T use their own specific formats. The MA short name formats (0-255) have been divided between the IEEE (0-31, 64-255) and the ITU-T (32-63), with five currently defined (1-4, 32). Even though the different standards bodies do not have specific support for the others formats a Y.1731 context can be configured using the IEEE format options.

1 (Primary VID) — Values 0 — 4094

2 (String) — Raw ASCII, excluding 0-31 decimal/0-1F hex (which are control characters) form the ASCII table

3 (2-octet integer) — 0 — 65535

4 (VPN ID) — Hex value as described in RFC 2685, *Virtual Private Networks Identifier*

32 (icc-format) — Exactly 13 characters from the ITU-T recommendation T.50.

**Note:** When a VID is used as the short MA name, 802.1ag will not support VLAN translation because the MA-ID must match all the MEPs. The default format for a short MA name is an

integer. Integer value 0 means the MA is not attached to a VID. This is useful for VPLS services on 7210 SAS platforms because the VID is locally significant.

Maintenance Domain Level (MD Level)/Maintenance Entity Group Level (MEG Level) is the numerical value (0-7) representing the width of the domain. The wider the domain, higher the numerical value, the farther the ETH-CFM packets can travel. It is important to understand that the level establishes the processing boundary for the packets. Strict rules control the flow of ETH-CFM packets and are used to ensure proper handling, forwarding, processing and dropping of these packets. To keep it simple ETH-CFM packets with higher numerical level values will flow through MEPs on MIPs on SAPs configured with lower level values. This allows the operator to implement different areas of responsibility and nest domains within each other. Maintenance association (MA) includes a set of MEPs, each configured with the same MA-ID and MD level used verify the integrity of a single service instance.

Maintenance Endpoint (MEP)/MEG Endpoint (MEP) are the workhorses of ETH-CFM. A MEP is the unique identification within the association (0-8191). Each MEP is uniquely identified by the MA-ID, MEPID tuple. This management entity is responsible for initiating, processing and terminating ETH-CFM functions, following the nesting rules. MEPs form the boundaries which prevent the ETH-CFM packets from flowing beyond the specific scope of responsibility. A MEP has direction, up or down. Each indicates the directions packets will be generated; UP toward the switch fabric, down toward the SAP away from the fabric. Each MEP has an active and passive side. Packets that enter the active point of the MEP will be compared to the existing level and processed accordingly. Packets that enter the passive side of the MEP are passed transparently through the MEP. Each MEP contained within the same maintenance association and with the same level (MA-ID) represents points within a single service. MEP creation on a SAP is allowed only for Ethernet ports with NULL, q-tags, q-in-q encapsulations. MEPs may also be created on SDP bindings.

To achieve better scaling on the 7210 SAS-E devices, it is recommended that the MEPs are configured at particular levels. The recommended levels are 0, 1, 3 and 7.

Maintenance Intermediate Point (MIP)/MEG Intermediate Point (MIP) are management entities between the terminating MEPs along the service path. These provide insight into the service path connecting the MEPs. MIPs only respond to Loopback Messages (LBM) and Linktrace Messages (LTM). All other CFM functions are transparent to these entities. Only one MIP is allowed per SAP or SDP. The creation of the MIPs can be done when the lower level domain is created (explicit). This is controlled by the use of the mhf-creation mode within the association under the bridge-identifier. MIP creation is supported on a SAP and SDP, not including Mesh SDP bindings. By default, no MIPs are created.

---

**NOTE:** The 7210 SAS platforms supports either only Ingress MIPs in some services or bi-directional MIPs (that is, ingress and egress MIPs) in some services. The table below lists the MIP and MEP support for different services on different platforms.

There are two locations in the configuration where ETH-CFM is defined. The domains, associations (including linkage to the service id), MIP creation method, common ETH-CFM functions and remote MEPs are defined under the top level **eth-cfm** command. It is important to note, when Y.1731 functions are required the context under which the MEPs are configured must follow the Y.1731 specific formats (domain format of none, MA format icc-format). Once these parameters have been entered, the MEP and possibly the MIP can be defined within the service under the SAP or SDP.

This is a general table that indicates the ETH-CFM support for the different services and endpoints. It is not meant to indicate the services that are supported or the requirements for those services on the individual platforms.

**Table 5: ETH-CFM Support Matrix for 7210 SAS-D**

Service	Ethernet Connection Type	Down MEP	UP MEP	MIP
Epipes	SAP (Access & Access-uplink SAP)	Yes	Yes	Ingress and Egress
VPLS	SAP (Access and Access-uplink SAP)	Yes	Yes	Ingress MIP only
RVPLS	SAP	Not Supported	Not Supported	Not Supported
IES	IES IPv4 interface	Not Supported	Not Supported	Not Supported
	SAP	Not Supported	Not Supported	Not Supported

**Table 6: ETH-CFM Support Matrix for 7210 SAS-E**

Service	Ethernet Connection Type	Down MEP	UP MEP	MIP
Epipe	SAP (Access and Access-uplink SAP)	Yes	Not Supported	Not Supported
VPLS	SAP (Access and Access-uplink SAP)	Yes	Not Supported	Ingress MIP only
RVPLS	SAP	Not Supported	Not Supported	Not Supported
IES	IES IPv4 interface	Not Supported	Not Supported	Not Supported
	SAP	Not Supported	Not Supported	Not Supported

**Table 7: ETH-CFM Support Matrix for 7210 SAS-K**

Service	Ethernet Connection Type	Down MEP	UP MEP	MIP
Epipe	SAP (Access & Access-uplink SAP)	Yes	Yes	Ingress and Egress
VPLS	SAP (Access and Access-uplink SAP)	Yes	Yes	Ingress and Egress
RVPLS	SAP	Not Supported	Not Supported	Not Supported
IES	IES IPv4 interface	Not Supported	Not Supported	Not Supported
	SAP	Not Supported	Not Supported	Not Supported

### Configuration Notes on CCM timer support

100ms timer value is supported only for service Down MEPs and G8032 Down MEPs on 7210 SAS-D. The minimum timer for service UP MEPs on 7210 SAS-D is one second. On 7210 SAS-E, the minimum timer value supported for Down MEPs (including G8032 Down MEPs) is 1 second.

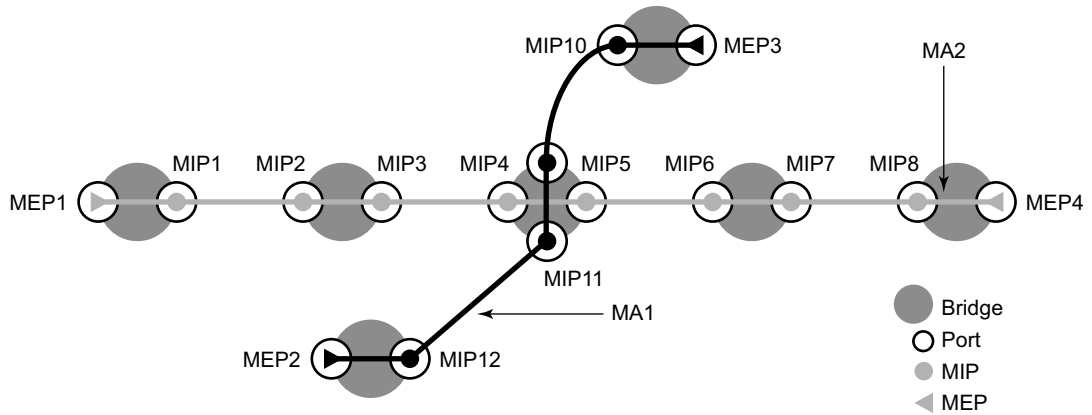

**Figure 5: MEP and MIP**

[Figure 6](#) shows the detailed IEEE representation of MEPs, MIPs, levels and associations, using the standards defined icons.

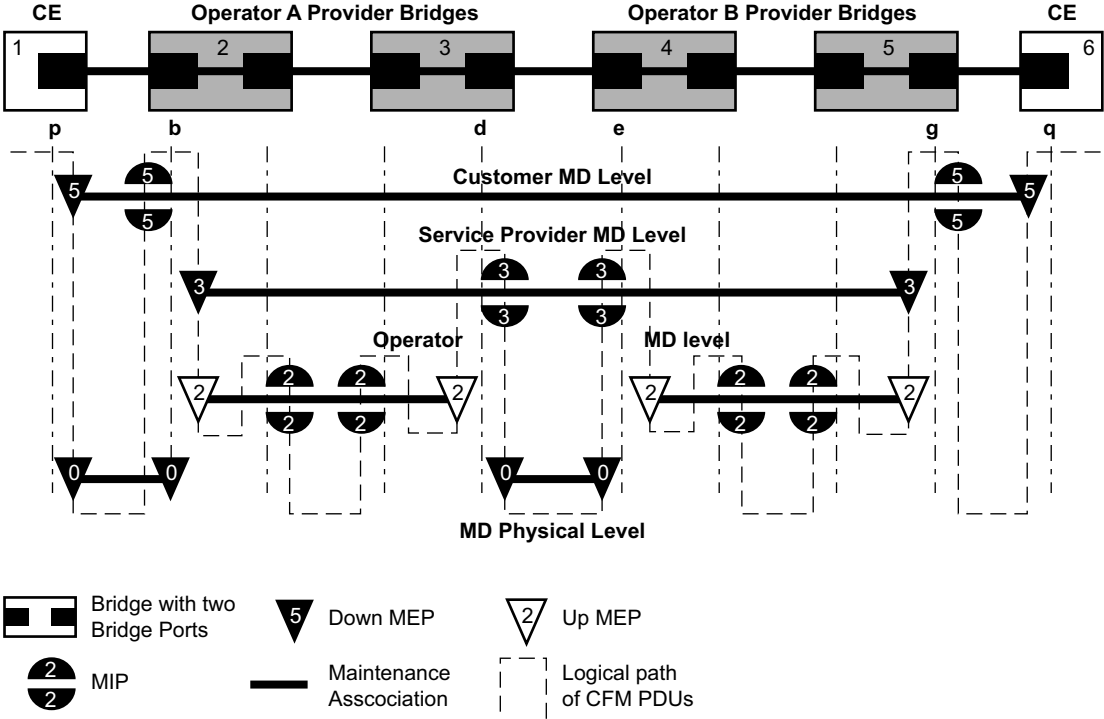
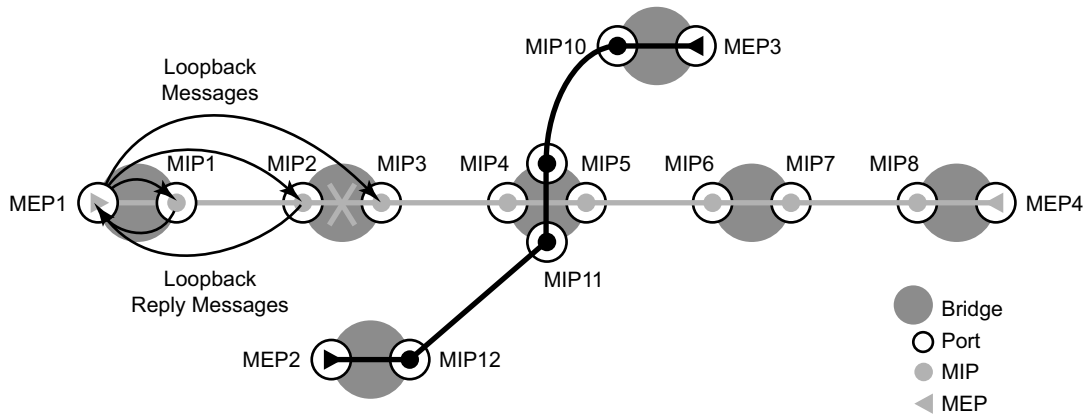

Figure 6: MEP, MIP and MD Levels

## Loopback

A loopback message is generated by an MEP to its peer MEP (Figure 7). The functions are similar to an IP ping to verify Ethernet connectivity between the nodes.



**Figure 7: CFM Loopback**

The following loopback-related functions are supported:

- Loopback message functionality on an MEP or MIP can be enabled or disabled.
- MEP — Supports generating loopback messages and responding to loopback messages with loopback reply messages.
- MIP — Supports responding to loopback messages with loopback reply messages when loopback messages are targeted to self.
- Displays the loopback test results on the originating MEP. There is a limit of ten outstanding tests per node.

## Linktrace

A linktrace message is originated by an MEP and targeted to a peer MEP in the same MA and within the same MD level (Figure 8). Its function is similar to IP traceroute. Traces a specific MAC address through the service. The peer MEP responds with a linktrace reply message after successful inspection of the linktrace message. The MIPs along the path also process the linktrace message and respond with linktrace replies to the originating MEP if the received linktrace message that has a TTL greater than 1 and forward the linktrace message if a look up of the target MAC address in the Layer 2 FIB is successful. The originating MEP shall expect to receive multiple linktrace replies and from processing the linktrace replies, it can put together the route to the target bridge.

A traced MAC address is carried in the payload of the linktrace message, the target MAC. Each MIP and MEP receiving the linktrace message checks whether it has learned the target MAC address. In order to use linktrace the target MAC address must have been learned by the nodes in the network. If so, a linktrace message is sent back to the originating MEP. Also, a MIP forwards the linktrace message out of the port where the target MAC address was learned.

The linktrace message itself has a multicast destination address. On a broadcast LAN, it can be received by multiple nodes connected to that LAN. But, at most, one node will send a reply.

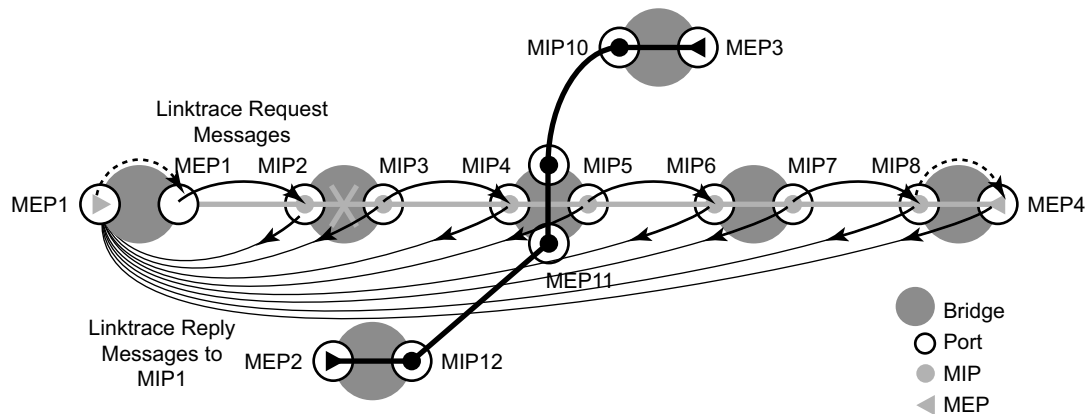

Fig\_13

**Figure 8: CFM Linktrace**

The following linktrace related functions are supported:

- Enable or disables linktrace functions on an MEP.

## Ethernet Connectivity Fault Management (ETH-CFM)

- MEP — Supports generating linktrace messages and responding with linktrace reply messages.
- Displays linktrace test results on the originating MEP. There is a limit of ten outstanding tests per node. Storage is provided for upto ten MEPs and for the last ten responses. If more than ten responses are received older entries will be overwritten.

## Continuity Check (CC)

A Continuity Check Message (CCM) is a multicast frame that is generated by a MEP and multicast to all other MEPs in the same MA. The CCM does not require a reply message. To identify faults, the receiving MEP maintains an internal list of remote MEPs it should be receiving CCM messages from.

This list is based off of the remote-mepid configuration within the association the MEP is created in. When the local MEP does not receive a CCM from one of the configured remote MEPs within a pre-configured period, the local MEP raises an alarm.

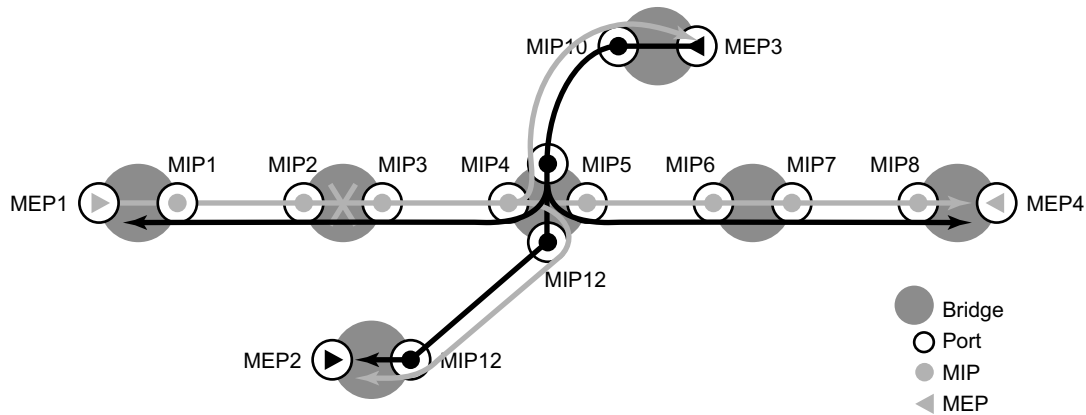

Figure 9: CFM Continuity Check

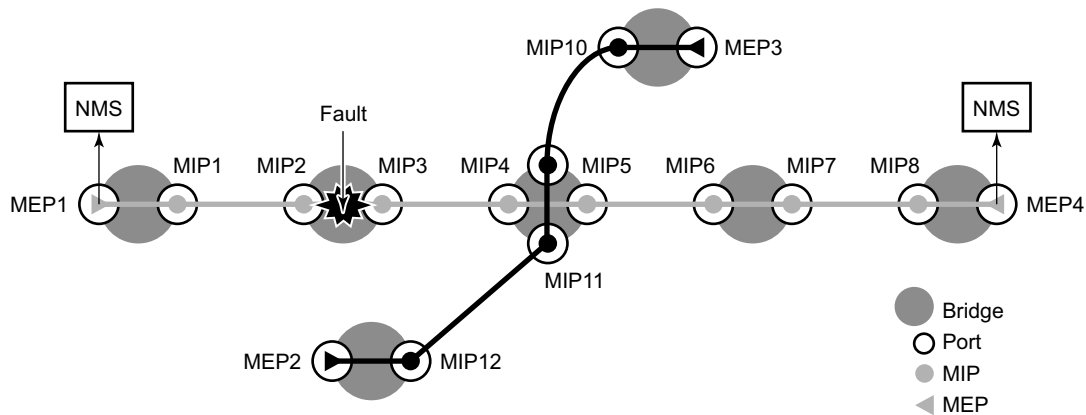

Figure 10: CFM CC Failure Scenario

The following functions are supported:

- Enable and disable CC for an MEP
- Configure and delete the MEP entries in the CC MEP monitoring database manually. It is only required to provision remote MEPs. Local MEPs shall be automatically put into the database when they are created.
- CCM transmit interval: 100ms (Supported only on 7210 SAS-D), 1s, 10s, 60s and 600s. Default: 10s.

When configuring MEPs with sub-second CCM intervals bandwidth consumption must be taken into consideration. Each CCM PDU is 100 bytes (800 bits). Taken individually this is a small value. However, the bandwidth consumption increases rapidly as multiple MEPs are configured with 10ms timers, 100 packets per second. Sub-second enabled MEPs are supported on the following:

- Down MEPs configured on Ethernet SAPs.
- Lowest MD-level, when multiple MEPs exist on same Ethernet SAP.
- Individual Ethernet tunnel paths requiring EAPs but not on the Ethernet tunnel itself. This requires a the MEPs to be part of the Y.1731 context because of the EAPS.
- CCM will declare a fault, when:
  - The CCM stops hearing from one of the remote MEPs for 3.5 times CC interval
  - Hears from a MEP with a LOWER MD level
  - Hears from a MEP that is not part of the local MEPs MA
  - Hears from a MEP that is in the same MA but not in the configured MEP list
  - Hears from a MEP in the same MA with the same MEP id as the receiving MEP
  - The CC interval of the remote MEP does not match the local configured CC interval
  - The remote MEP is declaring a fault
- An alarm is raised and a trap is sent if the defect is greater than or equal to the configured low-priority-defect value.
- Remote Defect Indication (RDI) is supported but by default is not recognized as a defect condition because the low-priority-defect setting default does not include RDI.

## Alarm Indication Signal (ETH-AIS Y.1731)

Alarm Indication Signal (AIS) provides an Y.1731 capable MEP the ability to signal a fault condition in the reverse direction of the MEP, out the passive side. When a fault condition is detected the MEP will generate AIS packets at the configured client levels and at the specified AIS interval until the condition is cleared. Currently a MEP configured to generate AIS must do so at a level higher than its own. The MEP configured on the service receiving the AIS packets is required to have the active side facing the receipt of the AIS packet and must be at the same level the AIS, The absence of an AIS packet for 3.5 times the AIS interval set by the sending node will clear the condition on the receiving MEP.

It is important to note that AIS generation is not supported to an explicitly configured endpoint. An explicitly configured endpoint is an object that contains multiple individual endpoints, as in PW redundancy.

---

## Test (ETH-TST Y.1731)

Ethernet test affords operators an Y.1731 capable MEP the ability to send an in service on demand function to test connectivity between two MEPs. The test is generated on the local MEP and the results are verified on the destination MEP. Any ETH-TST packet generated that exceeds the MTU will be silently dropped by the lower level processing of the node.

## Y.1731 Time Stamp Capability

Timestamps for different Y.1731 messages are obtained as follows:

- The 7210 SAS-E supports software based time stamping for one-way and two-way delay measurement tests. It uses the system clock (free-running or synchronized to NTP) to obtain the timestamps.
- The 7210 SAS-D support is as follows:
  - Y.1731 2-DM messages for Down MEPs uses hardware timestamps for both Rx (packets received by the node) and Tx (packets sent out of the node). The timestamps is obtained from a free-running hardware clock. It provides accurate 2-way delay measurements and it is not recommended to use for computing 1-way delay.
  - Y.1731 2-DM messages for UP MEPs, 1-DM for both Down MEPs and UP MEPs, and 2-SLM for both Down MEPs and UP MEPs use software based timestamps on Tx and hardware based timestamp on Rx. It uses the system clock (free-running or synchronized to NTP) to obtain the timestamps.
- The 7210 SAS-K supports hardware time-stamping for Y.1731 1-DM, 2-DM and SLM. The timestamp values are obtained using a synchronized clock. The synchronized clock provides timestamp values as below:
  - When neither PTP nor NTP is enabled in the system, the synchronized clock is same as free-run system clock. Thus, accurate two-way delay measurements are possible. However, one-way delay measurements can result in unexpected values.
  - When NTP is enabled in the system, the synchronized clock is derived by the NTP clock.
  - When PTP is enabled in the system, the synchronized clock is derived by PTP clock.

**NOTE:** Accurate results for one-way and two-way delay measurement tests using Y.1731 messages are obtained if the nodes are capable of time stamping packets in hardware.

### One-Way Delay Measurement (ETH-1DM Y.1731)

One-way delay measurement allows the operator the ability to check unidirectional delay between MEPs. An ETH-1DM packet is time stamped by the generating MEP and sent to the remote node. The remote node time stamps the packet on receipt and generates the results. The results, available from the receiving MEP, will indicate the delay and jitter. Jitter, or delay variation, is the difference in delay between tests. This means the delay variation on the first test will not be valid. It is important to ensure that the clocks are synchronized on both nodes to ensure the results are accurate. NTP can be used to achieve a level of wall clock synchronization between the nodes.

---

## Two-Way Delay Measurement (ETH-DMM Y.1731)

Two-way delay measurement is similar to one way delay measurement except it measures the round trip delay from the generating MEP. In this case wall clock synchronization issues will not influence the test results because four timestamps are used. This allows the remote nodes time to be removed from the calculation and as a result clock variances are not included in the results. The same consideration for first test and hardware based time stamping stated for one way delay measurement are applicable to two-way delay measurement.

Delay can be measured using one-way and two-way on demand functions. The two-way test results are available single-ended, test initiated, calculation and results viewed on the same node. There is no specific configuration under the MEP on the SAP in order to enabled this function. An example of an on demand test and results are below. The latest test result is stored for viewing. Further tests will overwrite the previous results. Delay Variation is only valid if more than one test has been executed.

```
oam eth-cfm two-way-delay-test d0:0d:1e:00:01:02 mep 101 domain 4 association 1
```

```
Two-Way-Delay-Test Response:
```

```
Delay 2955 microseconds          Variation 111 microseconds
```

```
# show eth-cfm mep 101 domain 4 association 1 two-way-delay-test
```

```
=====
```

```
Eth CFM Two-way Delay Test Result Table
```

```
=====
```

```
Peer Mac Addr          Delay (us)          Delay Variation (us)
```

```
-----
```

```
d0:0d:1e:00:01:02      2955                111
```

## Synthetic Loss Measurement (ETH-SL)

Alcatel-Lucent applied pre-standard OpCodes 53 (Synthetic Loss Reply) and 54 (Synthetic Loss Message) for the purpose of measuring loss using synthetic packets.

Notes: These will be changes to the assigned standard values in a future release. This means that the Release 4.0R6 is pre-standard and will not interoperate with future releases of SLM or SLR that supports the standard OpCode values.

This synthetic loss measurement approach is a single-ended feature that allows the operator to run on-demand and proactive tests to determine “in”, “out” loss and “unacknowledged” packets. This approach can be used between peer MEPs in both point to point and multipoint services. Only remote MEP peers within the association and matching the unicast destination will respond to the SLM packet.

The specification uses various sequence numbers in order to determine in which direction the loss occurred. Alcatel-Lucent has implemented the required counters to determine loss in each direction. In order to properly use the information that is gathered the following terms are defined;

- **Count** — The number of probes that are sent when the last frame is not lost. When the last frame(s) is or are lost, the count and unacknowledged equals the number of probes sent.
- **Out-Loss (Far-end)** — Packets lost on the way to the remote node, from test initiator to the test destination.
- **In-Loss (Near-end)** — Packet loss on the way back from the remote node to the test initiator.
- **Unacknowledged** — Number of packets at the end of the test that were not responded to.

The per probe specific loss indicators are available when looking at the on-demand test runs, or the individual probe information stored in the MIB. When tests are scheduled by Service Assurance Application (SAA) the per probe data is summarized and per probe information is not maintained. Any “unacknowledged” packets will be recorded as “in-loss” when summarized.

The on-demand function can be executed from CLI or SNMP. The on demand tests are meant to provide the carrier a way to perform on the spot testing. However, this approach is not meant as a method for storing archived data for later processing. The probe count for on demand SLM has a range of one to 100 with configurable probe spacing between one second and ten seconds. This means it is possible that a single test run can be up to 1000 seconds in length. Although possible, it is more likely the majority of on demand case can increase to 100 probes or less at a one second interval. A node may only initiate and maintain a single active on demand SLM test at any given time. A maximum of one storage entry per remote MEP is maintained in the results table. Subsequent runs to the same peer can overwrite the results for that peer. This means, when using on demand testing the test should be run and the results checked prior to starting another test.

The proactive measurement functions are linked to SAA. This backend provides the scheduling, storage and summarization capabilities. Scheduling may be either continuous or periodic. It also

allows for the interpretation and representation of data that may enhance the specification. As an example, an optional TVL has been included to allow for the measurement of both loss and delay or jitter with a single test. The implementation does not cause any interoperability because the optional TVL is ignored by equipment that does not support this. In mixed vendor environments loss measurement continues to be tracked but delay and jitter can only report round trip times. It is important to point out that the round trip times in this mixed vendor environments include the remote nodes processing time because only two time stamps will be included in the packet. In an environment where both nodes support the optional TLV to include time stamps unidirectional and round trip times is reported. Since all four time stamps are included in the packet the round trip time in this case does not include remote node processing time. Of course, those operators that wish to run delay measurement and loss measurement at different frequencies are free to run both ETH-SL and ETH-DM functions. ETH-SL is not replacing ETH-DM. Service Assurance is only briefly discussed here to provide some background on the basic functionality. To know more about SAA functions see [Service Assurance Agent Overview on page 91](#).

The ETH-SL packet format contains a test-id that is internally generated and not configurable. The test-id is visible for the on demand test in the display summary. It is possible for a remote node processing the SLM frames receives overlapping test-ids as a result of multiple MEPs measuring loss between the same remote MEP. For this reason, the uniqueness of the test is based on remote MEP-ID, test-id and Source MAC of the packet.

ETH-SL is applicable to up and down MEPs and as per the recommendation transparent to MIPs. There is no coordination between various fault conditions that could impact loss measurement. This is also true for conditions where MEPs are placed in shutdown state as a result of linkage to a redundancy scheme like MC-LAG. Loss measurement is based on the ETH-SL and not coordinated across different functional aspects on the network element. ETH-SL is supported on service based MEPs.

It is possible that two MEPs may be configured with the same MAC on different remote nodes. This causes various issues in the FDB for multipoint services and is considered a misconfiguration for most services. It is possible to have a valid configuration where multiple MEPs on the same remote node have the same MAC. In fact, this is likely to happen. In this release, only the first responder is used to measure packet loss. The second responder is dropped. Since the same MAC for multiple MEPs is only truly valid on the same remote node this should be an acceptable approach

There is no way for the responding node to understand when a test is completed. For this reason a configurable “inactivity-timer” determines the length of time a test is valid. The timer will maintain an active test as long as it is receiving packets for that specific test, defined by the test-id, remote MEP Id and source MAC. When there is a gap between the packets that exceeds the inactivity-timer the responding node responds with a sequence number of one regardless of what the sequence number was the instantiating node sent. This means the remote MEP accepts that the previous test has expired and these probes are part of a new test. The default for the inactivity timer is 100 second and has a range of 10 to 100 seconds.

## Synthetic Loss Measurement (ETH-SL)

The responding node is limited to a fixed number of SLM tests per platform. Any test that attempts to involve a node that is already actively processing more than the system limit of the SLM tests shows up as “out loss” or “unacknowledged” packets on the node that instantiated the test because the packets are silently discarded at the responder. It is important for the operator to understand this is silent and no log entries or alarms is raised. It is also important to keep in mind that these packets are ETH-CFM based and the different platforms stated receive rate for ETH-CFM must not be exceeded. ETH-SL provides a mechanism for operators to pro-actively trend packet loss for service based MEPs.

**Note:** On 7210 SAS-E, Rx and Tx timestamps is in CPU and on 7210 SAS-D, the Tx timestamp is CPU based and Rx is hardware based.

---

## Configuration Example

The following illustration, shows the configuration required for proactive SLM test using SAA.

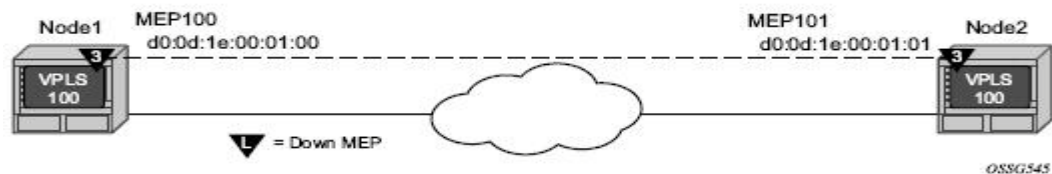

**Figure 11: SLM Example**

The output from the MIB is shown below as an example of an on-demand test. Node1 is tested for this example. The SAA configuration does not include the accounting policy required to collect the statistics before they are overwritten. NODE2 does not have an SAA configuration. NODE2 includes the configuration to build the MEP in the VPLS service context.

```
config>eth-cfm# info
-----
      domain 3 format none level 3
        association 1 format icc-based name "03-0000000100"
          bridge-identifier 100
          exit
          ccm-interval 1
          remote-mepid 101
        exit
      exit
-----
config>service>vpls# info
```

```

-----
    stp
      shutdown
    exit
    sap 1/1/3:100.100 create
    exit
    sap lag-1:100.100 create
      eth-cfm
        mep 100 domain 3 association 1 direction down
          ccm-enable
          mac-address d0:0d:1e:00:01:00
          no shutdown
      exit
    exit
  exit
no shutdown
-----
*A:7210SAS>config>service>vpls
*A:7210SAS>config>saa# info detail
-----
    test "SLM" owner "TiMOS CLI"
      no description
      type
        eth-cfm-two-way-slm 00:01:22:22:33:34 mep 1 domain 1 association 1 size 0
    fc "nc" count 100 timeout 1 interval 1
      exit
      trap-gen
        no probe-fail-enable
        probe-fail-threshold 1
        no test-completion-enable
        no test-fail-enable
        test-fail-threshold 1
      exit
      continuous
      no shutdown
    exit
-----
*A:7210SAS>config>saa#

The following sample output is meant to demonstrate the different loss conditions that an
operator may see. The total number of attempts is "100" is because the final probe in
the test was not acknowledged.

*A:7210SAS# show saa SLM42

=====
SAA Test Information
=====
Test name           : SLM42
Owner name          : TiMOS CLI
Description         : N/A
Accounting policy   : None
Continuous         : Yes
Administrative status : Enabled
Test type           : eth-cfm-two-way-slm 00:25:ba:02:a6:50 mep 4
                    : domain 1 association 1 fc "h1" count 100
                    : timeout 1 interval 1
Trap generation     : None
Test runs since last clear : 117

```

## Synthetic Loss Measurement (ETH-SL)

Number of failed test runs : 1  
 Last test result : Success

```
-----
```

Threshold					
Type	Direction	Threshold	Value	Last Event	Run #
Jitter-in	Rising	None	None	Never	None
	Falling	None	None	Never	None
Jitter-out	Rising	None	None	Never	None
	Falling	None	None	Never	None
Jitter-rt	Rising	None	None	Never	None
	Falling	None	None	Never	None
Latency-in	Rising	None	None	Never	None
	Falling	None	None	Never	None
Latency-out	Rising	None	None	Never	None
	Falling	None	None	Never	None
Latency-rt	Rising	None	None	Never	None
	Falling	None	None	Never	None
Loss-in	Rising	None	None	Never	None
	Falling	None	None	Never	None
Loss-out	Rising	None	None	Never	None
	Falling	None	None	Never	None
Loss-rt	Rising	None	None	Never	None
	Falling	None	None	Never	None

```
=====
```

Test Run: 116  
 Total number of attempts: 100  
 Number of requests that failed to be sent out: 0  
 Number of responses that were received: 100  
 Number of requests that did not receive any response: 0  
 Total number of failures: 0, Percentage: 0

(in ms)	Min	Max	Average	Jitter
Outbound :	8.07	8.18	8.10	0.014
Inbound :	-7.84	-5.46	-7.77	0.016
Roundtrip :	0.245	2.65	0.334	0.025

Per test packet:

Sequence	Outbound	Inbound	RoundTrip	Result
1	8.12	-7.82	0.306	Response Received
2	8.09	-7.81	0.272	Response Received
3	8.08	-7.81	0.266	Response Received
4	8.09	-7.82	0.270	Response Received
5	8.10	-7.82	0.286	Response Received
6	8.09	-7.81	0.275	Response Received
7	8.09	-7.81	0.271	Response Received
8	8.09	-7.82	0.277	Response Received
9	8.11	-7.81	0.293	Response Received
10	8.10	-7.82	0.280	Response Received
11	8.11	-7.82	0.293	Response Received
12	8.10	-7.82	0.287	Response Received
13	8.10	-7.82	0.286	Response Received
14	8.09	-7.82	0.276	Response Received
15	8.10	-7.82	0.284	Response Received
16	8.09	-7.82	0.271	Response Received
17	8.11	-7.81	0.292	Response Received

```
=====
```

The following is an example of an on demand tests that and the associated output. Only single test runs are stored and can be viewed after the fact.  
 #oam eth-cfm two-way-slm-test 00:25:ba:04:39:0c mep 4 domain 1 association 1 send-count

```

10 interval 1 timeout 1
Sending 10 packets to 00:25:ba:04:39:0c from MEP 4/1/1 (Test-id: 143)
Sent 10 packets, 10 packets received from MEP ID 3, (Test-id: 143)
(0 out-loss, 0 in-loss, 0 unacknowledged)

```

```
*A:7210SAS>show# eth-cfm mep 4 domain 1 association 1 two-way-slm-test
```

```
=====
Eth CFM Two-way SLM Test Result Table (Test-id: 143)
=====
```

Peer Mac Addr	Remote MEP	Count	In Loss	Out Loss	Unack
00:25:ba:04:39:0c	3	10	0	0	0

```
=====
*A:7210SAS>show#
```

## ETH-CFM QoS Considerations

UP MEPs and Down MEPs have been aligned as of this release to better emulate service data. When an UP MEP or DOWN MEP is the source of the ETH-CFM PDU the priority value configured, as part of the configuration of the MEP or specific test, will be treated as the Forwarding Class (FC) by the egress QoS policy. If there is no egress QoS policy the priority value will be mapped to the CoS values in the frame. However, egress QoS Policy may overwrite this original value. The Service Assurance Agent (SAA) uses [fc {fc-name}] to accomplish similar functionality.

UP MEPs and DOWN MEPs terminating an ETH-CFM PDU will use the received FC as the return priority for the appropriate response, again feeding into the egress QoS policy as the FC.

ETH-CFM PDUs received on the MPLS-SDP bindings will now properly pass the EXP bit values to the ETH-CFM application to be used in the response.

These are default behavioral changes without CLI options.

---

### Configuration guidelines

- On 7210 SAS platforms Ethernet Linktrace Response (ETH-LTR) is always sent out with priority 7.
- 7210 SAS platforms, send out all CFM packets as in-profile. Currently, there is no mechanism in the SAA tools to specify the profile of the packet.
- Other than as noted above, this behavior is applicable to all 7210 platforms where the feature supported has been added in both access-uplink mode and network mode of operation. Please see the Release Notes to know which platform and MEPs/MIPs support this feature.

## OAM Mapping

**NOTE:** Fault Propagation and OAM Mapping is not supported on 7210 SAS-E and 7210 SAS-K devices.

---

OAM mapping is a mechanism that enables a way of deploying OAM end-to-end in a network where different OAM tools are used in different segments. For instance, an Epipe service could span across the network using Ethernet access (CFM used for OAM), and Ethernet access (CFM used for OAM).

In the 7210 SAS implementation, the Service Manager (SMGR) is used as the central point of OAM mapping. It receives and processes the events from different OAM components, then decides the actions to take, including triggering OAM events to remote peers.

Fault propagation for CFM is by default disabled at the MEP level to maintain backward compatibility. When required, it can be explicitly enabled by configuration.

Fault propagation for a MEP can only be enabled when the MA is comprised of no more than two MEPs (point-to-point).

---

## CFM Connectivity Fault Conditions

CFM MEP declares a connectivity fault when its defect flag is equal to or higher than its configured lowest defect priority. The defect can be any of the following depending on configuration:

- DefRDICCM
- DefMACstatus
- DefRemoteCCM
- DefErrorCCM
- DefXconCCM

The following additional fault condition applies to Y.1731 MEPs:

- Reception of AIS for the local MEP level

Setting the lowest defect priority to allDef may cause problems when fault propagation is enabled in the MEP. In this scenario, when MEP A sends CCM to MEP B with interface status down, MEP B will respond with a CCM with RDI set. If MEP A is configured to accept RDI as a fault, then it gets into a dead lock state, where both MEPs will declare fault and never be able to recover. The default lowest defect priority is DefMACstatus, which will not be a problem when interface status

TLV is used. It is also very important that different Ethernet OAM strategies should not overlap the span of each other. In some cases, independent functions attempting to perform their normal fault handling can negatively impact the other. This interaction can lead to fault propagation in the direction toward the original fault, a false positive, or worse, a deadlock condition that may require the operator to modify the configuration to escape the condition. For example, overlapping Link Loss Forwarding (LLF) and ETH-CFM fault propagation could cause these issues.

For the DefRemoteCCM fault, it is raised when any remote MEP is down. So whenever a remote MEP fails and fault propagation is enabled, a fault is propagated to SMGR.

---

## CFM Fault Propagation Methods

When CFM is the OAM module at the other end, it is required to use any of the following methods (depending on local configuration) to notify the remote peer:

- Generating AIS for certain MEP levels
  - Sending CCM with interface status TLV “down”
  - Stopping CCM transmission
- 

**NOTE:** 7210 platforms expect that the fault notified using interface status TLV, is cleared explicitly by the remote MEP when the fault is no longer present on the remote node. On 7210 SAS-D, use of CCM with interface status TLV Down is not recommended to be configured with a Down MEP, unless it is known that the remote MEP clears the fault explicitly.

User can configure UP MEPs to use Interface Status TLV with fault propagation. Special considerations apply only to Down MEPs.

---

When a fault is propagated by the service manager, if AIS is enabled on the SAP/SDP-binding, then AIS messages are generated for all the MEPs configured on the SAP/SDP-binding using the configured levels.

Note that the existing AIS procedure still applies even when fault propagation is disabled for the service or the MEP. For example, when a MEP loses connectivity to a configured remote MEP, it generates AIS if it is enabled. The new procedure that is defined in this document introduces a new fault condition for AIS generation, fault propagated from SMGR, that is used when fault propagation is enabled for the service and the MEP.

The transmission of CCM with interface status TLV must be done instantly without waiting for the next CCM transmit interval. This rule applies to CFM fault notification for all services.

Notifications from SMGR to the CFM MEPs for fault propagation should include a direction for the propagation (up or down: up means in the direction of coming into the SAP/SDP-binding; down means in the direction of going out of the SAP/SDP-binding), so that the MEP knows what method to use. For instance, an up fault propagation notification to a down MEP will trigger an AIS, while a down fault propagation to the same MEP can trigger a CCM with interface TLV with status down.

For a specific SAP/SDP-binding, CFM and SMGR can only propagate one single fault to each other for each direction (up or down).

When there are multiple MEPs (at different levels) on a single SAP/SDP-binding, the fault reported from CFM to SMGR will be the logical OR of results from all MEPs. Basically, the first fault from any MEP will be reported, and the fault will not be cleared as long as there is a fault in any local MEP on the SAP/SDP-binding.

## Epipe Services

Down and up MEPs are supported for Epipe services as well as fault propagation. When there are both up and down MEPs configured in the same SAP/SDP-binding and both MEPs have fault propagation enabled, a fault detected by one of them will be propagated to the other, which in turn will propagate fault in its own direction.

---

## CFM Detected Fault

When a MEP detects a fault and fault propagation is enabled for the MEP, CFM needs to communicate the fault to SMGR, so SMGR will mark the SAP/SDP-binding faulty but still oper-up. CFM traffic can still be transmitted to or received from the SAP/SDP-binding to ensure when the fault is cleared, the SAP will go back to normal operational state. Since the operational status of the SAP/SDP-binding is not affected by the fault, no fault handling is performed. For example, applications relying on the operational status are not affected.

If the MEP is an up MEP, the fault is propagated to the OAM components on the same SAP/SDP-binding; if the MEP is a down MEP, the fault is propagated to the OAM components on the mate SAP/SDP-binding at the other side of the service.

## Service Down

This section describes procedures for the scenario where an Epipe service is down due to the following:

- Service is administratively shutdown. When service is administratively shutdown, the fault is propagated to the SAP/SDP-bindings in the service.

## LLF and CFM Fault Propagation

LLF and CFM fault propagation are mutually exclusive. CLI protection is in place to prevent enabling both LLF and CFM fault propagation in the same service, on the same node and at the same time. However, there are still instances where irresolvable fault loops can occur when the two schemes are deployed within the same service on different nodes. This is not preventable by the CLI. At no time should these two fault propagation schemes be enabled within the same service.

## 802.3ah EFM OAM Mapping and Interaction with Service Manager

802.3ah EFM OAM declares a link fault when any of the following occurs:

- Loss of OAMPDU for a certain period of time
- Receiving OAMPDU with link fault flags from the peer

When 802.3ah EFM OAM declares a fault, the port goes into operation state down. The SMGR communicates the fault to CFM MEPs in the service. OAM fault propagation in the opposite direction (SMGR to EFM OAM) is not supported.

---

## Fault Propagation to access dot1q/QinQ ports in Access-uplink mode

The Fault on the access uplink port brings down all access ports with services independent of the encap type of the access port (NULL or dot1q or QinQ), that is, support Link Loss Forwarding (LLF). The Fault propagated from the access-uplink port to access ports is based on configuration. The Fault is propagated only in a single direction, that is access-uplink port to access port.

The Fault on access-uplink port is detected using LoS and EFM-OAM.

Figure 12: Local Fault Propagation

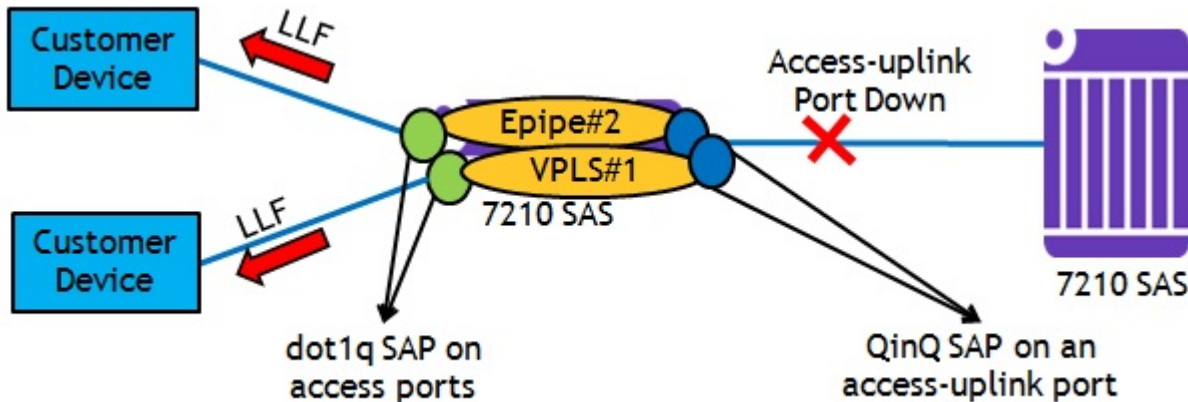

## Configuring Fault propagation:

To allow faults to be detected on access-uplink ports and be propagated to all the other interested access ports irrespective of their encapsulation, the concept of oper-group is used. In 7210, ports can be associated with oper-groups. Following bullets describe the use of oper-group functionality for fault-detection on a port and monitor-oper-group to track the status of the oper-group and propagate fault based on the operational state of the oper-group.

- Create an oper-group (For example: “uplink-to-7210”)
- Configure access-uplink port whose operational state needs to be tracked (For example: 1/1/20) and associate it with the oper-group created above (that is, uplink-to-7210)
- Configure dot1q access ports whose operational state needs to be driven by operational state of access-uplink port (For example: 1/1/1 and 1/1/5), as the monitor-oper-group
- To detect fault on access-uplink port and change the operational state, either Loss of Signal or EFM OAM can be used.
- When the operational state of access-uplink port changes from UP to DOWN changes the state of all access ports configured to monitor the group to “Down”. Similarly, a change in state from Down to UP, changes the operational state of the access port to UP. When the operational state of access port is brought down, the laser of the port is also shutdown. The command "*Hold timers*" are supported to avoid flapping of links.

## Configuration Example for fault propagation using oper-group

The following example displays an “oper-group” system configuration:

```
*A:7210SAS>config>system>oper-group# info detail
-----
```

## OAM Mapping

```
hold-time
  group-down 0
  group-up 4
exit
```

-----  
\*A: 7210SAS>config>system>oper-group#

**Note:** For more details on the CLI, see the “7210 SAS System Basics User Guide”.

---

## Service Assurance Agent Overview

In the last few years, service delivery to customers has drastically changed. Services such as are offered. The introduction of Broadband Service Termination Architecture (BSTA) applications such as Voice over IP (VoIP), TV delivery, video and high speed Internet services force carriers to produce services where the health and quality of Service Level Agreement (SLA) commitments are verifiable to the customer and internally within the carrier.

SAA is a feature that monitors network operations using statistics such as jitter, latency, response time, and packet loss. The information can be used to troubleshoot network problems, problem prevention, and network topology planning.

The results are saved in SNMP tables are queried by either the CLI or a management system. Threshold monitors allow for both rising and falling threshold events to alert the provider if SLA performance statistics deviate from the required parameters.

SAA allows two-way timing for several applications. This provides the carrier and their customers with data to verify that the SLA agreements are being properly enforced.

---

## Traceroute Implementation

In the 7210 SAS, for various applications, such as IP traceroute, control CPU inserts the timestamp in software.

When interpreting these timestamps care must be taken that some nodes are not capable of providing timestamps, as such timestamps must be associated with the same IP-address that is being returned to the originator to indicate what hop is being measured.

---

## NTP

Because NTP precision can vary (+/- 1.5ms between nodes even under best case conditions), SAA one-way latency measurements might display negative values, especially when testing network segments with very low latencies. The one-way time measurement relies on the accuracy of NTP between the sending and responding nodes.

## Ethernet CFM

Loopback (LBM), linktrace (LTR) and two-way-delay measurements (Y.1731 ETH-DMM) can be scheduled using SAA. Additional timestamping is required for non Y.1731 delay-measurement tests, to be specific, loopback and linktrace tests. An organization-specific TLV is used on both sender and receiver nodes to carry the timestamp information. Currently, timestamps are only applied by the sender node. This means any time measurements resulting from loopback and linktrace tests includes the packet processing time of the remote node. Since Y.1731 ETH-DMM uses a four time stamp approach to remove the remote processing time it should be used for accurate delay measurements.

The SAA versions of the CFM loopback, linktrace and ETH-DMM tests support send-count, interval, timeout, and FC. The existing CFM OAM commands have not been extended to support send-count and interval natively. The summary of the test results are stored in an accounting file that is specified in the SAA accounting-policy.

---

## Writing SAA Results to Accounting Files

SAA statistics enables writing statistics to an accounting file. When results are calculated an accounting record is generated.

In order to write the SAA results to an accounting file in a compressed XML format at the termination of every test, the results must be collected, and, in addition to creating the entry in the appropriate MIB table for this SAA test, a record must be generated in the appropriate accounting file.

---

## Accounting File Management

Because the SAA accounting files have a similar role to existing accounting files that are used for billing purposes, existing file management information is leveraged for these accounting (billing) files.

---

## Assigning SAA to an Accounting File ID

Once an accounting file has been created, accounting information can be specified and will be collected by the `config>log>acct-policy>` to file *log-file-id* context.

## Continuous Testing

When you configure a test, use the `config>saa>test>continuous` command to make the test run continuously. Use the `no continuous` command to disable continuous testing and `shutdown` to

disable the test completely. Once you have configured a test as continuous, you cannot start or stop it by using the `saa test-name [owner test-owner] {start | stop} [no-accounting]` command.

## Configuring SAA Test Parameters

The following example displays an SAA configuration:

```
*A:7210 SAS>config>saa# info
-----
test "abc"
  shutdown
  description "test"
  jitter-event rising-threshold 100 falling-threshold 10
  loss-event rising-threshold 300 falling-threshold 30
  latency-event rising-threshold 100 falling-threshold 20
exit
-----
*A:7210 SAS>config>saa#
```

## Y.1564 Testhead OAM tool

### Notes:

- 7210 SAS-D supports Port loopback with mac-swap and Y.1564 testhead OAM tool is supported only for Epipe and VPLS services.
- 7210 SAS-K supports per SAP loopback with mac-swap and Y.1564 testhead OAM tool only for Epipe and VPLS service. It does not support port loopback with mac-swap.
- 7210 SAS-E does not support port loopback with mac-swap and Y.1563 testhead OAM tool.
- In the Y.1564 testhead sections/paragraphs below, reference to port loopback implies use of 7210 SAS-D platforms. It is not applicable to 7210 SAS-K.

---

ITU-T Y.1564 defines the out-of-service test methodology to be used and parameters to be measured to test service SLA conformance during service turn up. It primarily defines 2 test phases. The first test phase defines service configuration test, which consists of validating whether the service is configured properly. As part of this test the throughput, Frame Delay, Frame Delay Variation (FDV), and Frame Loss Ratio (FLR) is measured for each service. This test is typically run for a short duration. The second test phase consists of validating the quality of services delivered to the end customer and is referred to as the service performance test. These tests are typically run for a longer duration and all traffic is generated up to the configured CIR for all the services simultaneously and the service performance parameters are measured for each the service.

The 7210 SAS supports service configuration test for user configured rate and measurement of delay, delay variation and frame loss ratio with the testhead OAM tool. 7210 testhead OAM tool supports bi-directional measurement and it can generate test traffic for only one service at a given time. It can validate if the user specified rate is available and compute the delay, delay variation and frame loss ratio for the service under test at the specified rate. It is capable of generating traffic upto 1G rate. On some 7210 SAS devices, the user needs to configure the resources of the front-panel port for use with this feature and some other 7210 SAS platforms resources needed for this feature is automatically allocated by software from the internal ports. For more information, see [Configuration Guidelines on page 102](#), below to which 7210 SAS platforms need user configuration and on which 7210 platforms software allocates it automatically.

**Figure 13** illustrates the remote loopback required and the flow of the frame through the network generated by the testhead tool.

**Figure 13: 7210 acting as traffic generator and traffic analyzer**

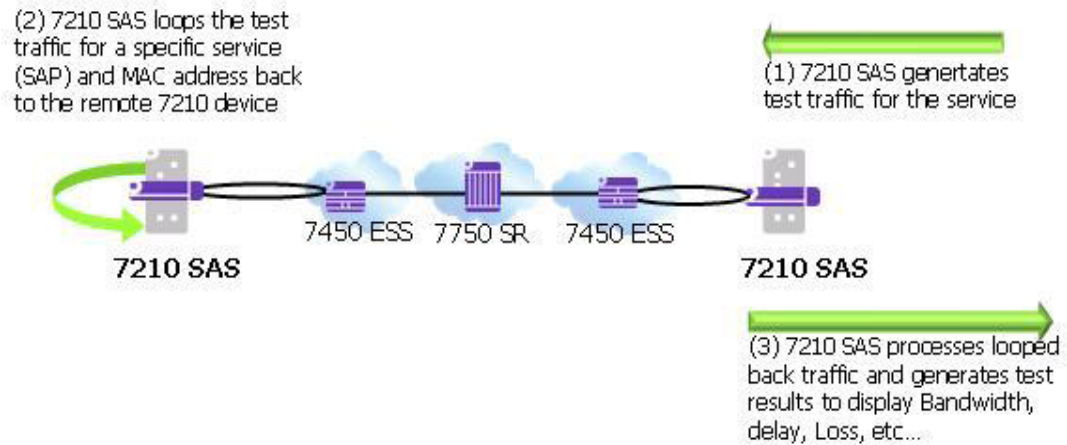

The tool allows the user to specify the frame payload header parameters independent of the test SAP configuration parameters to allow the user flexibility to test for different possible frame header encapsulations. This allows user to specify the appropriate VLAN tags, ethertype, and dot1p's, independent of the SAP configuration like with actual service testing. In other words, the software does not use the parameters (For example: SAP ID, Source MAC, and Destination MAC) during the invocation of the testhead tool to build the test frames. Instead it uses the parameters specified using the frame-payload CLI command tree. The software does not verify that the parameters specified match the service configuration used for testing, for example, software does not match if the VLAN tags specified matches the SAP tags, the ethertype specified matches the user configured port ethertype, and so on. It is expected that the user configures the frame-payload appropriately so that the traffic matches the SAP configuration.

7210 SAS supports Y.1564 testhead for performing CIR or PIR tests in color-aware mode. With this functionality, users can perform service turn-up tests to validate the performance characteristics (delay, jitter, and loss) for committed rate (CIR) and excess rate above CIR (that is, PIR rate). The testhead OAM tool uses the in-profile packet marking value and out-of-profile packet marking value, to differentiate between committed traffic and PIR traffic in excess of CIR traffic. Traffic within CIR (that is, committed traffic) is expected to be treated as in-profile traffic in the network and traffic in excess of CIR (that is, PIR traffic) is expected to be treated as out-of-profile traffic in the network, allowing the network to prioritize committed traffic over PIR traffic. The testhead OAM tool allows the user to configure individual thresholds for green or in-profile packets and out-of-profile or yellow packets. It is used by the testhead OAM tool to compare the measured value for green or in-profile packets and out-of-profile or yellow packets against the configured thresholds and report success or failure.

**NOTE:** 7210 SAS-K does not support performing CIR and PIR tests in color-aware mode. In the following text, color-aware mode related notes are not applicable to 7210 SAS-D.

The following functionality is supported by the testhead OAM tool:

- Supports configuration of only access SAPs as the test measurement point.
- Supports all port encapsulation supported on all svc-sap-types.
- Supported for only VPLS and Epipe service.
- Supports two-way measurement of service performance metrics. The tests must measure throughput, frame delay, frame delay variation, and frame loss ratio.
- On 7210 SAS-D, for two-way measurement of the service performance metrics, such as frame delay and frame delay variation, test frames (also called as marker packets) are injected at a low rate at periodic intervals. Frame delay and Frame delay variation is computed for these frames. On 7210 SAS-K, there are no separate marker packets used for delay measurements. Instead samples of the test traffic is used for measuring the delay. Hardware based timestamps is used for delay computation.
- 7210 SAS supports configuration of PIR rate and provides an option to measure the performance metrics for the frames. The testhead OAM tool, generates traffic upto the specified rate and measures service performance metrics such as, delay, jitter, loss for in-profile, and out-of-profile traffic.
- Testhead tool can generate traffic up to about 1G rate. CIR and PIR rate can be specified by the user and is rounded off the nearest rate the hardware supports by using the adaptation rule configured by the user.
- Allows the user to specify the different frame-sizes from 64 bytes - 9212 bytes.
- User can configure the following frame payload types- L2 payload, IP payload, and IP/TCP/UDP payload. Testhead tool will use the configured values for the IP header fields and TCP header fields based on the payload type configured. User is provided with an option to specify the data pattern to used in the payload field of the frame/packet.
- Allows the user to configure the duration of the test up to a maximum of 24 hours, 60 minutes, and 60 seconds. The test performance measurements by are done after the specified rate is achieved. At any time user can probe the system to know the current status and progress of the test.
- Supports configuration of the Forwarding Class (FC). It is expected that user will define consistent QoS classification policies to map the packet header fields to the FC specified on the test SAP ingress on the local node, in the network on the nodes through which the service transits, and on the SAP ingress in the remote node.
- Allows the user to configure a test-profile, also known as, a policy template that defines the test configuration parameters. User can start a test using a pre-configured test policy for a specific SAP and service. The test profile allows the user to configure the acceptance criteria. The acceptance criteria allows user to configure the thresholds that indicates the acceptable range for the service performance metrics. An event is generated if the test results exceed the configured thresholds. For more information, see the CLI section below. At the end of the test, the measured values for FD, FDV, and FLR are compared against the configured thresholds to determine the PASS or FAIL criteria and to generate a trap to

the management station. If the acceptance criteria is not configured, the test result is declared to be PASS, if the throughput is achieved and frame-loss is 0 (zero).

- ITU-T Y.1564 specifies different test procedures as follows. CIR and PIR configuration tests are supported by the testhead tool.
  - CIR and PIR configuration test (color-aware and non-color aware).
  - Traffic policing test (color-aware and non-color aware) is supported. Traffic policing tests can be executed by the user by specifying a PIR to be 125% of the desired PIR. Traffic policing test can be executed in either color-aware mode or color-blind (non-color-aware) mode.
- ITU-T Y.1564 specifies separate test methodology for color-aware and non-color-aware tests. The standard requires a single test to provide the capability to generate both green-color/in-profile traffic for rates within CIR and yellow-color or out-of-profile traffic for rates above CIR and within EIR. The 7210 SAS testhead marks test packets appropriately when generating the traffic, as SAP ingress does not support color-aware metering, it is not possible to support EIR color-aware, and traffic policing color-aware tests end-to-end in a network (that is, from test SAP to test SAP). Instead, It is possible to use the tests to measure the performance parameters from the other endpoint (example Access-uplink SAP) in the service, through the network, to the remote test SAP, and back again to the local test SAP.
- The 7210 SAS Y.1564 testhead is applicable only for VPLS and Epipe services.

## Pre-requisites for using the Testhead Tool

This section describes the pre-requisites a user must be aware of before using the testhead OAM tool. It is divided into three sections. First, the generic pre-requisites applicable to all 7210 SAS platforms is listed, followed by pre-requisites specific to 7210 SAS-D platform and then followed by pre-requisites specific for 7210 SAS-K.

---

### Generic pre-requisites for use of testhead tool (applicable for all 7210 SAS platforms):

- It is expected that the user will configure the appropriate ACL and QoS policies to ensure that the testhead traffic is processed as desired by the local and remote node/SAP. In particular, QoS policies in use must ensure that the rate in use for the SAP ingress meters exceed or are equal to the user configured rate for testhead tests and the classification policies map the testhead packets to the appropriate FCs/queues (the FC classification must match the FC specified in the CLI command testhead-test) using the packet header fields configured in the frame-payload. Similarly, ACL policies must ensure that testhead traffic is not blocked.
- The testhead OAM tool does not check the state of the service or the SAPs on the local endpoint before initiating the tests. The operator must ensure that the service and SAPs used for the test are UP before the tests are started. If they are not, the testhead tool will report a failure.
- The port configuration of the ports used for validation (For example: access port on which the test SAP is configured and access-uplink port) must not be modified after the testhead tool is invoked. Any modifications can be made only when the testhead tool is not running.
- Testhead tool can be used to test only unicast traffic flows. It must not be used to test BUM traffic flows.
- Only out-of-service performance metrics can be measured using testhead OAM tool. For in-service performance metrics, user has the option to use SAA based Y.1731/CFM tools.

This section describes some pre-requisites to use the testhead tool on 7210 SAS-D.

- The configuration guidelines and pre-requisites that are to be followed when the port loopback with mac-swap feature is used standalone, applies to its use along with testhead tool. For more information, see the description in the “7210 SAS-D, E, K Interfaces User Guide”.
- User must configure resources for ACL MAC criteria in ingress-internal-tcam using the command `config>system> resource-profile> ingress-internal-tcam> acl-sap-ingress> mac-match-enable`. Additionally they must allocate resources to egress ACL MAC or IPv4 or IPv6 64-bit criteria (using the command `config>system> resource-profile> egress-`

internal-tcam> acl-sap-egress> mac-ipv4-match-enable or mac-ipv6-64bit-enable or mac-ipv4-match-enable). Testhead tool uses resources from these resource pools. If no resources are allocated to these pools or no resources are available for use in these pools, then testhead fails to function. Testhead needs a minimum of about 6 entries from the ingress-internal-tcam pool and 2 entries from the egress-internal-tcam pool. If user allocates resources to egress ACLs IPv6 128-bit match criteria (using the command *config> system> resource-profile> egress-internal-tcam> acl-sap-egress> ipv6-128bit-match-enable*), then testhead fails to function.

- For both Epipe and VPLS service, the test can be used to perform only a point-to-point test between the given source and destination MAC address. Port loopback mac-swap functionality must be used for both Epipe and VPLS services. The configured source and destination MAC address is associated with the two SAPs configured in the service and used as the two endpoints. In other words, the user configured source MAC and destination MAC addresses are used by the testhead tool on the local node to identify the packets as belonging to testhead application and are processed appropriately at the local end and at the remote end these packets are processed by the port loopback with mac-swap application.
- Configure the MACs (source and destination) statically for VPLS service.
- Port loopback must be in use on both the endpoints (that is, the local node, the port on which the test SAP is configured and the remote node, the port on which the remote SAP is configured for both Epipe and VPLS services. Port loopback with mac-swap must be setup by the user on both the local end and the remote end before invoking the testhead tool. These must match appropriately for traffic to flow, else there will be no traffic flow and the testhead tool reports a failure at the end of the completion of the test run.
- Additionally, port loopback with mac-swap must be used at both the ends and if any services/SAPs are configured on the test port, they need to be shutdown to avoid packets being dropped on the non-test SAP. The frames generated by the testhead tool will egress the access SAP and ingress back on the same port, using the resources of the 2 internal loopback ports (one for testhead and another for mac-swap functionality), before being sent out to the network side (typically an access-uplink SAP) to the remote end". At the remote end, it is expected that the frames will egress the SAP under test and ingress back in again through the same port, going through another loopback (with mac-swap) before being sent back to the local node where the testhead application is running.
- The FC specified is used to determine the queue to enqueue the marker packets generated by testhead application on the egress of the test SAP on the local node.
- The use of port loopback is service affecting. It affects all the services configured on the port. It is not recommended to use a SAP, if the port on which they are configured, is used to transport the service packets towards the core. As, a port loopback is required for the testhead to function correctly, doing so might result in loss of connectivity to the node when in-band management is in use. Additionally, all services being transported to the core will be affected.

- It also affects service being delivered on that SAP. Only out-of-service performance metrics can be measured using testhead OAM tool. For in-service performance metrics, user has the option to use SAA based Y.1731/CFM tools.
- Testhead tool uses marker packets with special header values. The QoS policies and ACL policies need to ensure that same treatment as accorded to testhead traffic is given to marker packets. Marker packets are IPv4 packet with IP option set and IP protocol set to 252. It uses the src and dst MAC addresses, Dot1p, IP ToS, IP DSCP, IP TTL, IP source address and destination address as configured in the frame-payload. It does not use the IP protocol and TCP/UDP port numbers from the frame-payload configured. If the payload-type is "l2", IP addresses are set to 0.0.0.0, IP TTL is set to 0, IP TOS is set to 0 and DSCP is set to be, if these values are not explicitly configured in the frame-payload. Ethertype configured in the frame-payload is not used for marker packets, it is always set to ethertype = 0x0800 (ethertype for IPv4) as marker packets are IPv4 packets. QoS policies applied in the network needs to be configured such that the classification for marker packets is similar to service packets. An easy way to do this is by using the header fields that are common across marker packets and service packets, such as MAC (src and dst) addresses, VLAN ID, Dot1p, IPv4 (src and dst) addresses, IP DSCP, and IP ToS. Use of other fields which are different for marker packets and service packets is not recommended. ACL policies in the network must ensure that marker packets are not dropped.
- The mac-swap loopback port, the testhead loopback port and the uplink port must not be modified after the testhead tool is invoked. Any modifications can be made only when the testhead tool is not running.
- Link-level protocols (For example: LLDP, EFM, and other protocols) must not be enabled on the port on which the test SAP is configured. In general, no other traffic must be sent out of the test SAP when the testhead tool is running.
- The frame payload must be configured such that number of tags match the number of SAP tags. For example: For 0.\* SAP, the frame payload must be untagged or priority tagged and it cannot contain another tag following the priority tag.

The following list the pre-requisites for use of testhead functionality on 7210 SAS-K:

- For both Epipe and VPLS service, the test can be used to perform only a point-to-point test between the given source and destination MAC address. SAP loopback mac-swap functionality must be used for both Epipe and VPLS services. The configured source and destination MAC address is associated with the two SAPs configured in the service and used as the two endpoints.
- It is recommended to configure the MACs (source and destination) statically for VPLS service.
- SAP loopback needs to be configured only on the remote endpoint, that is, on the remote node on which the remote SAP is configured in both Epipe and VPLS services. SAP loopback with mac-swap must be setup by the user on the remote end before invoking the testhead tool. The testhead tool injects packets on SAP ingress, hence a SAP loopback on the local endpoint (where the test SAP is located) is not required.

- Use of per SAP loopback does not affect other services configured on the same port. It does affect service being delivered on that SAP.
  - A cookie used to identify testhead packets is added after the protocol headers for every frame generated by the testhead tool. This cookie is used to identify testhead generated frames. The cookie follows immediately after the protocol header configured by the user (For example: in a TCP/IP packet configured by the user, the cookie is added immediately after the TCP/IP header, and forms the first 8 bytes of the payload, after which the data pattern specified by the user is added to the packet).
  - 7210 SAS-K does not require any loopback ports to be assigned for testhead OAM tool.
-

## Configuration Guidelines

This section provide the configuration guidelines for this feature (that is, testhead OAM tool). It is applicable to all the platforms discussed in this guide unless a specific platform is called out explicitly.

- SAPs configured on LAG cannot be configured for testing with testhead tool. Other than the test SAP, other service endpoints (For example: SAPs/SDP-Bindings) configured in the service can be over a LAG.
- On 7210 SAS-D, software automatically assigns the resources associated with internal ports for use with this feature.  
On 7210 SAS-D, testhead OAM tool uses internal loopback ports.
- On 7210 SAS-D, port loopback with mac-swap is used at both ends and all services on the port on which the test SAP is configured and SAPs in the VPLS service, other than the test SAP should be shutdown or should not receive any traffic.
- The configured CIR/PIR rate is rounded off to the nearest available hardware rates. User is provided with an option to select the adaptation rule to use (similar to support available for QoS policies).
- 7210 SAS supports all port speeds (that is, up to 1G rate). On 7210 SAS-D, the user needs to configure the appropriate loopback port to achieve a desired rate. For example, user must dedicate the resources of a 1G port, if intended to test rates to go up to 1G. On 7210 SAS-D, the FC specified is used to determine the queue to enqueue the marker packets generated by testhead application on the egress of the test SAP on the local node.
- ITU-T Y.1564 recommends to provide an option to configure the CIR step-size and the step-duration for the service configuration tests. This is not supported directly in 7210 SAS. It can be achieved by SAM or a third-party NMS system or an application with configuration of the desired rate and duration to correspond to the CIR step-size and step duration and repeating the test a second time, with a different value of the rate (that is, CIR step size) and duration (that is, step duration) and so on.
- Testhead waits for about 5 seconds at the end of the configured test duration before collecting statistics. This allows for all in-flight packets to be received by the node and accounted for in the test measurements. User cannot start another test during this period.
- When using testhead to test bandwidth available between SAPs configured in a VPLS service, operators must ensure that no other SAPs in the VPLS service are exchanging any traffic, particularly BUM traffic and unicast traffic destined to either the local test SAP or the remote SAP. BUM traffic eats into the network resources which is also used by testhead traffic.
- It is possible that test packets (both data and/or marker packets) remain in the loop created for testing when the tests are killed. This is highly probably when using QoS policies with very less shaper rates resulting in high latency for packets flowing through the network loop. User must remove the loop at both ends once the test is complete or when the test is stopped and wait for a suitable time before starting the next test for the same service, to

ensure that packets drain out of the network for that service. If this is not done, then the subsequent tests might process and account these stale packets, resulting in incorrect results. Software cannot detect stale packets in the loop as it does not associate or check each and every packet with a test session

- Traffic received from the remote node and looped back into the test port (where the test SAP is configured) on the local end (that is, the end where the testhead tool is invoked) is dropped by hardware after processing (and is not sent back to the remote end). The SAP ingress QoS policies and SAP ingress filter policies must match the packet header fields specified by the user in the testhead profile, except that the source/destination MAC addresses are swapped.
- Latency is not be computed if marker packets are not received by the local node where the test is generated and printed as 0 (zero), in such cases. If jitter = 0 and latency > 0, it means that jitter calculated is less than the precision used for measurement. There is also a small chance that jitter was not actually calculated, that is, only one value of latency has been computed. This typically indicates a network issue, rather than a testhead issue.
- When the throughput is not met, FLR cannot be calculated. If the measured throughput is approximately +/-10% of the user configured rate, FLR value is displayed; else software prints "Not Applicable". The percentage of variance of measured bandwidth depends on the packet size in use and the configured rate.
- On 7210 SAS-D, the user must not use the CLI command to clear statistics of the test SAP port, testhead loopback port and MAC swap loopback port when the testhead tool is running. The port statistics are used by the tool to determine the Tx/Rx frame count.
- On 7210 SAS-D, testhead tool generates traffic at a rate slightly above the CIR. The additional bandwidth is attributable to the marker packets used for latency measurements. This is not expected to affect the latency measurement or the test results in a significant way.
- If the operational throughput is 1kbps and it is achieved in the test loop, the throughput computed could still be printed as 0 if it is < 1Kbps (0.99 kbps, for example). Under such cases, if FLR is PASS, the tool indicates that the throughput has been achieved.
- The testhead tool displays a failure result if the received count of frames is less than the injected count of frames, even though the FLR might be displayed as 0. This happens due to truncation of FLR results to 6 decimal places and can happen when the loss is very less.
- As the rate approaches 1Gbps or the maximum bandwidth achievable in the loop, user needs to account for the marker packet rate and the meter behavior while configuring the CIR rate. In other words, if the user wants to test 1Gbps for 512 bytes frame size, then they will need to configure about 962396Kbps, instead of 962406Kbps, the maximum rate that can be achieved for this frame-size. In general, they would need to configure about 98%-99% (based on packet size) of the maximum possible rate to account for marker packets when they need to test at rates which are closer to bandwidth available in the network. The reason for this is that at the maximum rate, injection of marker packets by CPU will result in drops of either the injected data traffic or the marker packets

themselves, as the net rate exceeds the capacity. These drops cause the testhead to always report a failure, unless the rate is marginally reduced.

- Testhead works with L2 rate, that is, the rate after subtracting the L1 overhead. The L1 overhead is due to IFG and Preamble added to every Ethernet frame and is typically about 20 bytes (IFG = 12 bytes and Preamble = 8 bytes). Depending on the frame size configured by the user, testhead tool computes the L2 rate and does not allow the user to configure a value greater than it. For 512 bytes Ethernet frame, L2 rate is 962406Kbps and L1 rate is 1Gbps.
- It is not expected that the operator will use the testhead tool to measure the throughput or other performance parameters of the network during the course of network event. The network events could be affecting the other SAP/SDP-Binding/PW configured in the service. Examples are transition of a SAP due to G8032 ring failure, transition of active/standby SDP-Binding/PW due to link or node failures.
- The 2-way delay (also known as “latency”) values measured by Testhead tool is more accurate than obtained using OAM tools, as the timestamps are generated in hardware.
- 7210 SAS does not support color-aware metering on access SAP ingress, therefore, any color-aware packets generated by the testhead is ignored on access SAP ingress. 7210 SAS service access port, access-uplink port, or network port can mark the packets appropriately on egress to allow the subsequent nodes in the network to differentiate the in-profile and out-of-profile packets and provide them with appropriate QoS treatment. 7210 SAS access-uplink ingress and network port ingress is capable of providing appropriate QoS treatment to in-profile and out-of-profile packets.
- The marker packets are sent over and above the configured CIR or PIR rate, the tool cannot determine the number of green packets injected and the number of yellow packets injected individually. Therefore, marker packets are not accounted in the injected or received green or in-profile and yellow or out-of-profile packet counts. They are only accounted for the Total Injected and the Total Received counts. So, the FLR metric accounts for marker packet loss (if any), while green or yellow FLR metric does not account for any marker packet loss.
- Marker packets are used to measure green or in-profile packets latency and jitter and the yellow or out-of-profile packets latency and jitter. These marker packets are identified as green or yellow based on the packet marking (Example: dot1p). The latency values can be different for green and yellow packets based on the treatment provided to the packets by the network QoS configuration.

- The following table provides details of SAP encapsulation that are supported for Testhead on 7210 SAS-D.

**Table 8: SAP Encapsulations supported for testhead on 7210 SAS-D**

<b>Epipe service configured with svc-sap-type</b>	<b>Test SAP Encapsulations</b>
null-star	Null, :* , 0.* , Q.*
Any	Null , :0 , :Q , :Q1.Q2
dot1q-preserve	:Q

---

## Configuring testhead tool parameters

**NOTE:** Please note that on the 7210 SAS-D node “mac swap” and “testhead loopback port” are internally configured.

The following example displays a port loopback mac-swap using the service and SAP:

```
configure> system> loopback-no-svc-port testhead <port-id>
*A:7210SAS>config>system# info
-----
.....
resource-profile
    ingress-internal-tcam
        qos-sap-ingress-resource 5
        exit
        acl-sap-ingress 5
        exit
    exit
    egress-internal-tcam
    exit
    exit
.....
```

The following example displays a port loopback with mac-swap on the remote end:

```
*A:7210SAS# configure system loopback-no-svc-port mac-swap 1/1/8
*A:7210SAS# configure system
*A:7210SAS>config>system# info
-----
alarm-contact-input 1
    shutdown
    exit
alarm-contact-input 2
    shutdown
    exit
alarm-contact-input 3
    shutdown
    exit
alarm-contact-input 4
    shutdown
    exit
resource-profile
    ingress-internal-tcam
        qos-sap-ingress-resource 5
        exit
        acl-sap-ingress 5
        exit
    exit
    egress-internal-tcam
    exit
    exit
.....
```

The following example displays a testhead profile:

```
*A:7210SAS# configure test-oam testhead-profile 1
*A:7210SAS>config>test-oam>testhd-prof# info
-----
description "Testhead_Profile_1"
  frame-size 512
  rate cir 100 adaptation-rule max pir 200
  dot1p in-profile 2 out-profile 4
  frame-payload 1 payload-type tcp-ipv4 create
    description "Frame_Payload_1"
    dscp "af11"
    dst-ip ipv4 2.2.2.2
    dst-mac 00:00:00:00:00:02
    src-mac 00:00:00:00:00:01
    dst-port 50
    src-port 40
    ip-proto 6
    ip-tos 8
    ip-ttl 64
    src-ip ipv4 1.1.1.1
  exit
acceptance-criteria 1 create
  jitter-rising-threshold 100
  jitter-rising-threshold-in 100
  jitter-rising-threshold-out 100
  latency-rising-threshold 100
  latency-rising-threshold-in 100
  latency-rising-threshold-out 100
  loss-rising-threshold 100
  loss-rising-threshold-in 100
  loss-rising-threshold-out 100
  cir-threshold 1000
  pir-threshold 2000
  exit
-----
*A:7210SAS>config>test-oam>testhd-prof#
```

The following command is used to execute the testhead profile:

```
*A:7210SAS# oam testhead testhead-profile 1 frame-payload 1 sap 1/1/2 test-me owner own-
erme color-aware enable
```

## Port Loopback for Ethernet ports

**Notes:**

- Port loopback with mac-swap is not supported on 7210 SAS-E.
- Only per SAP loopback with mac-swap is supported on 7210 SAS-K. Port loopback with mac-swap is not supported.

7210 devices support port loopback for ethernet ports. There are two flavors of port loopback commands - port loopback without mac-swap and port loopback with mac-swap. Both these commands are helpful for testing the service configuration and measuring performance parameters such as throughput, delay, and jitter on service turn-up. Typically, a third-party external test device is used to inject packets at desired rate into the service at a central office location. For detailed information on port loop back functionality see 7210 SAS-D,E,K Interfaces guide.

---

## SAP loopback for Ethernet SAPs

Per SAP loopback with mac-swap is supported and it is useful for testing the service configuration and measuring performance parameters such as throughput, delay, and jitter on service turn-up. Typically, testhead OAM tool is used to inject packets at desired rate into the service from the remote site. It is also possible to use a third-party external test device is used to inject packets at desired rate into the service at a central office location. For detailed information on SAP loopback functionality, see 7210 SAS-D,E,K Services User Guide.

# Diagnostics Command Reference

- [OAM Commands on page 109](#)
- [SAA Commands on page 117](#)

---

## OAM Commands

### Base Operational Commands

#### GLOBAL

- **ping** *[ip-address | dns-name]* [**rapid** | **detail**] [**ttl** *time-to-live*] [**tos** *type-of-service*] [**size** *bytes*] [**pattern** *pattern*] [**source** *ip-address*] [**interval** *seconds*] [{**next-hop** *ip-address*} | {**interface** *interface-name*}] [**bypass-routing**] [**count** *requests*] [**do-not-fragment**] [**router** *router-instance*] **service-name** *service-name*] [**timeout** *timeout*] [**fc** *fc-name*]
  - **traceroute** *[ip-address | dns-name]* [**ttl** *ttl*] [**wait** *milli-seconds*] [**no-dns**][**source** *ip-address*] [**tos** *type-of-service*] [**router** [*router-instance* / **service-name** *service-name*]]
  - **oam**
    - **dns** **target-addr** *dns-name* **name-server** *ip-address* [**source** *ip-address*] [**count** *send-count*] [**timeout** *timeout*] [**interval** *interval*] [**record-type** {*ipv4-a-record*|*ipv6-aaaa-record*}]
    - **saa** *test-name* [**owner** *test-owner*] {**start** | **stop**} [**no-accounting**]
- 

### LSP Diagnostics

#### GLOBAL

- **oam**
  - **lsp-trace** *lsp-name* [**path** *path-name*]
  - **lsp-trace** **prefix** *ip-prefix/mask* [**path-destination** *ip-address*] [**interface** *if-name* | **next-hop** *ip-address*]
  - **lsp-trace** **static** *lsp-name* [**assoc-channel** *ipv4|non-ip|none*] [**dest-global-id** *global-id* **dest-node-id** *node-id*] [**force**] [**path-type** *active* | *working* | *protect*]
  - **lsp-trace** *lsp-name* [**path** *path-name*]
  - **lsp-trace** **prefix** *ip-prefix/mask* [**path-destination** *ip-address*] [**interface** *if-name* | **next-hop** *ip-address*]
  - **lsp-trace** **static** *lsp-name* [**assoc-channel** *ipv4|non-ip|none*] [**path-type** *active* | *working* | *protect*]

### TWAMP (applicable only to 7210 SAS-D)

#### GLOBAL

- **configure**
  - **test-oam**
    - **twamp**
      - **server**
        - [**no**] **prefix** {*ip-prefix* / *mask*}

- [no] **description** *description string*
- [no] **max-conn-prefix** *count*
- [no] **max-sess-prefix** *count*
- [no] **shutdown**
- [no] **inactivity-timeout** *seconds*
- [no] **max-conn-server** *count*
- [no] **max-sess-server** *count*
- [no] **port** *number*

---

[no] **shutdown**

## Ethernet in the First Mile (EFM) Commands

### GLOBAL

- **oam**
    - **efm** *port-id* **local-loopback** {**start** | **stop**}
    - **efm** *port-id* **remote-loopback** {**start** | **stop**}
- 

## ETH-CFM OAM Commands

### oam

- **eth-cfm** **eth-test** *mac-address* **mep** *mep-id* **domain** *md-index* **association** *ma-index* [**priority** *priority*] [**data-length** *data-length*]
  - **eth-cfm** **linktrace** *mac-address* **mep** *mep-id* **domain** *md-index* **association** *ma-index* [**tfl** *tfl-value*]
  - **eth-cfm** **loopback** *mac-address* **mep** *mep-id* **domain** *md-index* **association** *ma-index* [**send-count** *send-count*] [**size** *data-size*] [**priority** *priority*]
  - **eth-cfm** **one-way-delay-test** *mac-address* **mep** *mep-id* **domain** *md-index* **association** *ma-index* [**priority** *priority*]
  - **eth-cfm** **two-way-delay-test** *mac-address* **mep** *mep-id* **domain** *md-index* **association** *ma-index* [**priority** *priority*]
  - **eth-cfm** **two-way-slm-test** *mac-address* **mep** *mep-id* **domain** *md-index* **association** *ma-index* [**fc** {**fc-name**}] [**profile** {**in**|**out**}] [**count** *send-count*] [**size** *data-size*] [**timeout** *timeout*] [**interval** *interval*]
-

## Y.1564 Testhead OAM commands (For 7210 SAS-D devices)

```

config
  — test-oam
    — testhead-profile profile-id create
      — [no] acceptance-criteria acceptance-criteria-id create
        — [no] cir-threshold threshold
        — [no] jitter-rising-threshold threshold
        — [no] jitter-rising-threshold-in threshold
        — [no] jitter-rising-threshold-out threshold
        — [no] latency-rising-threshold threshold
        — [no] latency-rising-threshold-in threshold
        — [no] latency-rising-threshold-out threshold
        — [no] loss-rising-threshold threshold
        — [no] loss-rising-threshold-in threshold
        — [no] loss-rising-threshold-out threshold
        — [no] pir-threshold threshold
      — [no] description description-string
      — dot1p in-profile dot1p-value out-profile dot1p-value
      — no dot1p
      — no frame-payload payload-id [payload-type [l2|tcp-ipv4|udp-ipv4|ipv4] create
      — no frame-payload payload
        — [no] data-pattern data-pattern
        — [no] description description-string
        — [no] dscp dscp-name
        — [no] dst-ip ipv4 ipv4-address
        — [no] dst-mac ieee-address [ieee-address-mask]
        — [no] dst-port dst-port-number
        — [no] ethertype 0x0600..0xffff
        — [no] ip-proto ip-protocol-number
        — [no] ip-tos type-of-service
        — [no] ip-ttl ttl-value
        — [no] src-ip ipv4 ipv4-address
        — [no] src-mac ieee-address [ieee-address-mask]
        — [no] src-port src-port-number
        — [no] vlan-tag-1 vlan-id vlan-id [tpid tpid] [dot1p dot1p-value]
        — [no] vlan-tag-2 vlan-id vlan-id [tpid tpid] [dot1p dot1p-value]
      — [no] frame-size frame-size
      — [no] rate cir cir-rate-in-kbps [cir-adaptation-rule adaptation-rule] [pir cir-rate-i n-kbp]
      — [no] test-completion-trap-enable
      — [no] test-duration [hours hours] [minutes minutes] [seconds seconds]
      — [no] test-duration

```

---

## Y.1564 Testhead OAM commands on 7210 SAS-K

```

config
  — test-oam
    — testhead-profile profile-id create
      — [no] acceptance-criteria acceptance-criteria-id create
        — [no] cir-threshold threshold
        — [no] jitter-rising-threshold threshold
        — [no] jitter-rising-threshold-in threshold

```

- [no] **jitter-rising-threshold-out** *threshold*
- [no] **latency-rising-threshold** *threshold*
- [no] **latency-rising-threshold-in** *threshold*
- [no] **latency-rising-threshold-out** *threshold*
- [no] **loss-rising-threshold** *threshold*
- [no] **loss-rising-threshold-in** *threshold*
- [no] **loss-rising-threshold-out** *threshold*
- [no] **pir-threshold** *threshold*
- [no] **description** *description-string*
- **no frame-payload** *payload-id* [**payload-type** [12|tcp-ipv4|udp-ipv4|ipv4] **create**]
- **no frame-payload** *payload*
  - [no] **data-pattern** *data-pattern*
  - [no] **description** *description-string*
  - [no] **dscp** *dscp-name*
  - [no] **dst-ip** *ipv4 ipv4-address*
  - [no] **dst-mac** *ieee-address [ieee-address-mask]*
  - [no] **dst-port** *dst-port-number*
  - [no] **ethertype** *0x0600..0xffff*
  - [no] **ip-proto** *ip-protocol-number*
  - [no] **ip-tos** *type-of-service*
  - [no] **ip-ttl** *ttl-value*
  - [no] **src-ip** *ipv4 ipv4-address*
  - [no] **src-mac** *ieee-address [ieee-address-mask]*
  - [no] **src-port** *src-port-number*
  - [no] **vlan-tag-1** *vlan-id vlan-id [tpid tpid] [dot1p dot1p-value]*
  - [no] **vlan-tag-2** *vlan-id vlan-id [tpid tpid] [dot1p dot1p-value]*
- [no] **frame-size** *frame-size*
- [no] **rate** *cir-rate-in-kbps* [**cir-adaptation-rule** *adaptation-rule*] [**pir** *cir-rate-in-kbps*]
- [no] **test-completion-trap-enable**
- [no] **test-duration** [**hours** *hours*] [**minutes** *minutes*] [**seconds** *seconds*]
- [no] **test-duration**

## Y.1564 Testhead OAM Commands for 7210 SAS-D

**oam**

- **testhead** *test-name* **owner** *owner-name* **testhead-profile** *profile-id* [**frame-payload** *frame-payload-id*]  
**sap** *sap-id* [**fc** *fc-name*] [**acceptance-criteria** *acceptance-criteria-id*] [**color-aware** **enable**|**disable**]
- **testhead** *test-name* **owner** *owner-name* **stop**

## Y.1564 Testhead OAM Commands for 7210 SAS-K

### oam

- **testhead** *test-name* **owner** *owner-name* **testhead-profile** *profile-id* [**frame-payload** *frame-payload-id*]  
**sap** *sap-id* [**fc** *fc-name*] [**acceptance-criteria** *acceptance-criteria-id*]
- **testhead** *test-name* **owner** *owner-name* **stop**

## Show commands

```
show
  — test-oam
      — testhead-profile profile-id
show
  — testhead [test-name owner test-owner] [detail]
```

## Clear commands

- clear**
- **test-oam**
- **twamp server**
- **testhead result** [*test-name*] **owner** [*test-owner*]
- **testhead testhead-profile** *profile-id*

---

## SAA Commands

---

### config

#### — **saa**

- **[no] test** *test-name* [**owner** *test-owner*]
  - **accounting-policy** *acct-policy-id*
  - **no accounting-policy**
  - **[no] continuous**
  - **description** *description-string*
  - **no description**
  - **[no] jitter-event** **rising-threshold** *threshold* [**falling-threshold** *threshold*] [**direction**]
  - **[no] latency-event** **rising-threshold** *threshold* [**falling-threshold** *threshold*] [**direction**]
  - **[no] loss-event** **rising-threshold** *threshold* [**falling-threshold** *threshold*] [**direction**]
  - **probe-history** {**keep**|**drop**|**auto**}
  - **[no] shutdown**
  - **trap-gen**
    - **[no] probe-fail-enable**
    - **[no] probe-fail-threshold** *0..15*
    - **[no] test-completion-enable**
    - **[no] test-fail-enable**
    - **[no] test-fail-threshold** *0..15*
- **[no] type**
  - **dns** **target-addr** *dns-name* **name-server** *ip-address* [**source** *ip-address*] [**send-count** *send-count*] [**timeout** *timeout*] [**interval** *interval*]
  - **eth-cfm-linktrace** *mac-address* **mep** *mep-id* **domain** *md-index* **association** *ma-index* [**ttl** *ttl-value*] [**fc** {*fc-name*}] [**count** *send-count*] [**timeout** *timeout*] [**interval** *interval*] [**record-type** {*ipv4-a-record*|*ipv6-aaaa-record*}]
  - **eth-cfm-loopback** *mac-address* **mep** *mep-id* **domain** *md-index* **association** *ma-index* [**size** *data-size*] [**fc** {*fc-name*}] [**count** *send-count*] [**timeout** *timeout*] [**interval** *interval*]
  - **eth-cfm-two-way-delay** *mac-address* **mep** *mep-id* **domain** *md-index* **association** *ma-index* [**fc** {*fc-name*}] [**count** *send-count*] [**timeout** *timeout*] [**interval** *interval*]
  - **eth-cfm-two-way-slm** *mac-address* **mep** *mep-id* **domain** *md-index* **association** *ma-index* [**fc** {*fc-name*}] [**profile** {*in*|*out*}] [**count** *send-count*] [**size** *data-size*] [**timeout** *timeout*] [**interval** *interval*]
  - **icmp-ping** [*ip-address* | *dns-name*] [**rapid** | **detail**] [**ttl** *time-to-live*] [**tos** *type-of-service*] [**size** *bytes*] [**pattern** *pattern*] [**source** *ip-address*] [**interval** *seconds*] [{**next-hop** *ip-address*}] [{**interface** *interface-name*}] [**bypass-routing**] [**count** *requests*] [**do-not-fragment**] [*router-instance* | **service-name** *service-name*] [**timeout** *timeout*] [**fc** {*fc-name*}]
  - **icmp-trace** [*ip-address* | *dns-name*] [**ttl** *time-to-live*] [**wait** *milli-seconds*] [**source** *ip-address*] [**tos** *type-of-service*] [*router-instance* | **service-name** *service-name*]

## Show Commands

- ```

show
  — eth-cfm
    — association [ma-index] [detail]
    — cfm-stack-table [port [port-id] [vlan qtag [.qtag]]][level 0..7] [direction up / down]
    — cfm-stack-table
    — cfm-stack-table port [{all-ports}] [level <0..7>] [direction up / down]
    — cfm-stack-table <port-id> [vlan <qtag [.qtag]>] [level <0..7>] [direction up / down]
    — domain [md-index] [association ma-index | all-associations] [detail]
    — mep mep-id domain md-index association ma-index [loopback] [linktrace]
    — mep mep-id domain md-index association ma-index [remote-mepid mep-id | all-remote-mepids]
    — mep mep-id domain md-index association ma-index eth-test-results [remote-peer mac-address]
    — mep mep-id domain md-index association ma-index one-way-delay-test [remote-peer mac-address]
    — mep mep-id domain md-index association ma-index two-way-delay-test [remote-peer mac-address]
    — mep mep-id domain md-index association ma-index two-way-slm-test [remote-peer mac-address]
    — mip
    — system-config
  — saa [test-name] [owner test-owner]
  — test-oam (applicable only to 7210 SAS-D)
    — twamp server
      — server all
      — server prefix ip-prefix/mask
      — server

```

## Clear Commands

- ```

clear
  — saa [test-name] [owner test-owner]
  — test-oam (applicable only to 7210 SAS-D)
    — twamp server
      — server

```

---

## OAM and SAA Command Hierarchies

---

### Operational Commands

#### shutdown

**Syntax** [no] shutdown

**Context** config>saa>test

**Description** In order to modify an existing test it must first be shut down. When a test is created it will be in shutdown mode until a **no shutdown** command is executed.

A **shutdown** can only be performed if a test is not executing at the time the command is entered.

Use the **no** form of the command to set the state of the test to operational.

#### shutdown

**Syntax** [no] shutdown

**Context** config>test-oam>ldp-treetrace  
config>test-oam>twamp>server  
config>test-oam>twamp>server>prefix

**Description** This command suspends the background process running the LDP ECMP OAM tree discovery and path probing features. The configuration is not deleted.

Use the **no** form of the command to enable the background process.

#### dns

**Syntax** dns target-addr dns-name name-server ip-address [source ip-address] [count send-count] [timeout timeout] [interval interval] [record-type {ipv4-a-record|ipv6-aaaa-record}]

**Context** oam

**Description** This command performs DNS name resolution. If ipv4-a-record is specified, dns-names are queried for A-records only.

**Parameters** ip-address — The IP address of the primary DNS server.

<b>Values</b>	ipv4-address - a.b.c.d
	ipv6-address - x:x:x:x:x:x:x (eight 16-bit pieces)
	x:x:x:x:x:d.d.d.d

## Operational Commands

x - [0..FFFF]H

d - [0..255]D

**timeout** *timeout* — The **timeout** parameter in seconds, expressed as a decimal integer. This value is used to override the default **timeout** value and is the amount of time that the router will wait for a message reply after sending the message request. Upon the expiration of message timeout, the requesting router assumes that the message response will not be received. Any response received after the request times out will be silently discarded.

**Default** 5

**Values** 1 — 120

**interval** *interval* — The **interval** parameter in seconds, expressed as a decimal integer. This parameter is used to override the default request message send interval and defines the minimum amount of time that must expire before the next message request is sent.

If the **interval** is set to 1 second, and the **timeout** value is set to 10 seconds, then the maximum time between message requests is 10 seconds and the minimum is 1 second. This depends upon the receipt of a message reply corresponding to the outstanding message request.

**Default** 1

**Values** 1 — 10

**record-type** — Specifies a record type.

**Values** ipv4-a-record — A record specific mapping a host name to an IPv4 address.  
ipv6-aaaa-record — A record specific to the Internet class that stores a single IPv6 address.

## ping

**Syntax** ping [*ip-address* | *dns-name*] [**rapid** | **detail**] [**ttl** *time-to-live*] [**tos** *type-of-service*] [**size** *bytes*] [**pattern** *pattern*] [**source** *ip-address* | *dns-name*] [**interval** *seconds*] [{**next-hop** *ip-address*} | {**interface** *interface-name*} | **bypass-routing**] [**count** *requests*] [**do-not-fragment**] [**router** *router-instance* | **service-name** *service-name*] [**timeout** *timeout*]

**Context** <GLOBAL>

**Description** This command verifies the reachability of a remote host.

**Parameters** *ip-address* — The far-end IP address to which to send the **icmp-ping** request message in dotted decimal notation.

**Note:** IPv6 is supported only for "Management" instance of the router.

**Values** ipv4-address: a.b.c.d  
ipv6-address: x:x:x:x:x:x:x (eight 16-bit pieces)  
x:x:x:x:x:d.d.d.d  
x: [0 .. FFFF]H  
d: [0 .. 255]D

*dns-name* — The DNS name of the far-end device to which to send the **icmp-ping** request message, expressed as a character string.

**rapid** — Packets will be generated as fast as possible instead of the default 1 per second.

**detail** — Displays detailed information.

**tll** *time-to-live* — The TTL value for the IP TTL, expressed as a decimal integer.

**Values** 1 — 128

**tos** *type-of-service* — Specifies the service type.

**Values** 0 — 255

**size** *bytes* — The request packet size in bytes, expressed as a decimal integer.

**Values** 0 — 16384

**pattern** *pattern* — The data portion in a ping packet will be filled with the pattern value specified. If not specified, position info will be filled instead.

**Values** 0 — 65535

**source** *ip-address* — Specifies the IP address to be used.

**Note:** IPv6 is supported only for "Management" instance of the router.

**Values**

ipv4-address:	a.b.c.d
ipv6-address:	x:x:x:x:x:x:x (eight 16-bit pieces)
	x:x:x:x:x:d.d.d.d
x:	[0 .. FFFF]H
d:	[0 .. 255]D

**router** *router-instance* — Specifies the router name or service ID.

**Values** *router-name:* Base

**Default** Base

**service-name** *service-name* - Specifies the service name as an integer or string.

**bypass-routing** — Specifies whether to send the ping request to a host on a directly attached network bypassing the routing table.

**interface** *interface-name* — Specifies the name of an IP interface. The name must already exist in the **config>router>interface** context.

**next-hop** *ip-address* — Only displays static routes with the specified next hop IP address.

**Note:** IPv6 is supported only for "Management" instance of the router.

**Values**

ipv4-address:	a.b.c.d (host bits must be 0)
ipv6-address:	x:x:x:x:x:x:x (eight 16-bit pieces)
	x:x:x:x:x:d.d.d.d
x:	[0 — FFFF]H
d:	[0 — 255]

**interval** *seconds* — The interval parameter in seconds, expressed as a decimal integer. This parameter is used to override the default request message send interval and defines the minimum amount of time that must expire before the next message request is sent.

## Operational Commands

If the interval is set to 1 second, and the timeout value is set to 10 seconds, then the maximum time between message requests is 10 seconds and the minimum is 1 second. This depends upon the receipt of a message reply corresponding to the outstanding message request.

**Values** 1 — 10000

**count requests** — Specifies the number of times to perform an OAM ping probe operation. Each OAM echo message request must either timeout or receive a reply before the next message request is sent.

**Values** 1 — 100000

**Default** 5

**do-not-fragment** — Sets the DF (Do Not Fragment) bit in the ICMP ping packet.

**fc-name** — The forwarding class of the MPLS echo request encapsulation.

**Values** be|l2|af|l1|h2|ef|h1|nc

**Default** nc

**timeout seconds** — Overrides the default **timeout** value and is the amount of time that the router will wait for a message reply after sending the message request. Upon the expiration of message timeout, the requesting router assumes that the message response will not be received. A 'request timeout' message is displayed by the CLI for each message request sent that expires. Any response received after the request times out will be silently discarded.

**Default** 5

**Values** 1 — 10

## traceroute

**Syntax** **traceroute** [*ip-address* | *dns-name*] [**t***ttl*] [**w***wait milli-seconds*] [**n***no-dns*] [**s***source ip-address*] [**t***tos type-of-service*] [**r***router router-instance* | **s***service-name service-name*]

**Context** Global

**Description** The TCP/IP traceroute utility determines the route to a destination address. DNS lookups of the responding hosts is enabled by default.

```
*A:ALA-1# traceroute 192.168.xx.xx4
traceroute to 192.168.xx.xx4, 30 hops max, 40 byte packets
 1 192.168.xx.xx4 0.000 ms 0.000 ms 0.000 ms
*A:ALA-1#
```

**Parameters** *ip-address* — The far-end IP address to which to send the traceroute request message in dotted decimal notation.

**Note:** IPv6 is supported only for "Management" instance of the router.

**Values**

ipv4-address:	a.b.c.d
ipv6-address:	x:x:x:x:x:x:x (eight 16-bit pieces)
	x:x:x:x:x:d.d.d.d
x:	[0 .. FFFF]H
d:	[0 .. 255]D

**dns-name** — The DNS name of the far-end device to which to send the traceroute request message, expressed as a character string.

**ttl ttl** — The maximum Time-To-Live (TTL) value to include in the traceroute request, expressed as a decimal integer.

**Values** 1 — 255

**wait milliseconds** — The time in milliseconds to wait for a response to a probe, expressed as a decimal integer.

**Default** 5000

**Values** 10 — 60000

**no-dns** — When the **no-dns** keyword is specified, DNS lookups of the responding hosts will not be performed, only the IP addresses will be printed.

**Default** DNS lookups are performed

**source ip-address** — The source IP address to use as the source of the probe packets in dotted decimal notation. If the IP address is not one of the device's interfaces, an error is returned.

**tos type-of-service** — The type-of-service (TOS) bits in the IP header of the probe packets, expressed as a decimal integer.

**Values** 0 — 255

**router router-name** — Specify the alphanumeric character string up to 32 characters.

**Values** Base, Management

**service-name service-name** - Specifies the service name as an integer or string.

## lsp-trace

**Syntax** **lsp-trace** *lsp-name* [**path** *path-name*]

**lsp-trace prefix** *ip-prefix/mask* [**path-destination** *ip-address* [**interface** *if-name* | **next-hop** *ip-address*]]

**lsp-trace static** *lsp-name* [**assoc-channel** *ipv4|none|non-ip*] [**path-type** *active* | **working** | **protect**]

**NOTE:** Options common to all **lsp-trace** cases: [**detail**] [**downstream-map-tlv** *downstream-map-tlv*] [**fc** *fc-name*] [**profile** *in|out*]] [**interval** *interval*] [**max-fail** *no-response-count*] [**max-ttl** *max-label-ttl*] [**min-ttl** *min-label-ttl*] [**probe-count** *probes-per-hop*] [**size** *octets*] [**src-ip-address** *ip-address*] [**timeout** *timeout*]

## Operational Commands

**Context** oam  
config>saa>test>type

**Description** This command, when used with the **static** option, performs in-band on-demand LSP traceroute tests for static MPLS-TP LSPs. For other LSP types, the **static** option should be excluded and these are described elsewhere in this user guide.

The **lsp-trace static** command performs an LSP trace using the protocol and data structures defined in the RFC 4379, Detecting Multi-Protocol Label Switched (MPLS) Data Plane Failures, as extended by RFC 6426, MPLS On-Demand Connectivity Verification and Route Tracing.

The LSP trace operation is modeled after the IP traceroute utility which uses ICMP echo request and reply packets with increasing TTL values to determine the hop-by-hop route to a destination IP.

In an LSP trace, the originating device creates an MPLS echo request packet for the LSP to be tested with increasing values of the TTL in the outermost label. The MPLS echo request packet is sent through the data plane and awaits a TTL exceeded response or the MPLS echo reply packet from the device terminating the LSP. The devices that reply to the MPLS echo request packets with the TTL exceeded and the MPLS echo reply are displayed.

In MPLS-TP, the echo request and echo reply messages are always sent in-band over the LSP, either in a G-ACh channel or encapsulated as an IP packet below the LSP label.

**Parameters** *lsp-name* — Name that identifies an LSP to ping. The LSP name can be up to 32 characters long.

**path** *path-name* — The LSP path name along which to send the LSP trace request.

**Values** Any path name associated with the LSP.

**Default** The active LSP path.

**control-channel** { **none** | **non-ip** } — The encapsulation format to use for the MPLS echo request and echo reply packet.

**Values** none — IP encapsulation in an MPLS labeled packet

**Values** non-ip — MPLS-TP encapsulation without UDP/IP headers, in an MPLS-TP G-ACh on the LSP using channel type 0x025.

**Default** non-ip

**size** *octets* — The size in octets, expressed as a decimal integer, of the MPLS echo request packet, including the IP header but not the label stack. The request payload is padded with zeroes to the specified size. Note that an OAM command is not failed if the user entered a size lower than the minimum required to build the packet for the echo request message. The payload is automatically padded to meet the minimum size.

**Values** [104..9198]

**Default** 1

**src-ip-address** *ip-addr* — Specifies the source IP address. This option is used when an OAM packet must be generated from a different address than the node's system interface address. An example is when the OAM packet is sent over an LDP LSP and the LDP LSR-ID of the corresponding LDP session to the next-hop is set to an address other than the system interface address.

**Values** ipv4-address: a.b.c.d

**min-ttl** *min-label-ttl* — The minimum TTL value in the MPLS label for the LSP trace test, expressed as a

decimal integer.

**Default** 1

**Values** 1 — 255

**max-ttl** *max-label-ttl* — The maximum TTL value in the MPLS label for the LDP tree-trace test, expressed as a decimal integer.

**Values** 1 — 255

**Default** 30

**max-fail** *no-response-count* — The maximum number of consecutive MPLS echo requests, expressed as a decimal integer that do not receive a reply before the trace operation fails for a given TTL.

**Values** 1 — 255

**Default** 5

**probes-per-hop** — The number of messages to send, expressed as a decimal integer. The **send-count** parameter is used to override the default number of message requests sent. Each message request must either timeout or receive a reply before the next message request is sent. The message **interval** value must be expired before the next message request is sent.

**Values** 1 — 10

**Default** 1

**timeout** *timeout* — The **timeout** parameter in seconds, expressed as a decimal integer. This value is used to override the default **timeout** value and is the amount of time that the router will wait for a message reply after sending the message request. Upon the expiration of message timeout, the requesting router assumes that the message response will not be received. A 'request timeout' message is displayed by the CLI for each message request sent that expires. Any response received after the request times out will be silently discarded.

**Values** 1 — 60

**Default** 3

**interval** *interval* — The **interval** parameter in seconds, expressed as a decimal integer. This parameter is used to override the default request message send interval and defines the minimum amount of time that must expire before the next message request is sent.

If the **interval** is set to 1 second, and the **timeout** value is set to 10 seconds, then the maximum time between message requests is 10 seconds and the minimum is 1 second. This depends upon the receipt of a message reply corresponding to the outstanding message request.

**Values** 1 — 10

**Default** 1

**downstream-map-tlv** {*ddmap* | *dsmmap*} — LSP Trace commands with this option can only be executed if the control-channel is set to none. The DSMAP/DDMAP TLV is only included in the echo request message if the egress interface is either a numbered IP interface, or an unnumbered IP interface. The TLV will not be included if the egress interface is of type unnumbered-mpls-tp.

**fc** *fc-name* — The **fc** and **profile** parameters are used to indicate the forwarding class and profile of the MPLS echo request packet.

## Operational Commands

When an MPLS echo request packet is generated in CPM and is forwarded to the outgoing interface, the packet is queued in the egress network queue corresponding to the specified fc and profile parameter values. The marking of the packet's EXP is dictated by the LSP-EXP mappings on the outgoing interface.

When the MPLS echo request packet is received on the responding node, The fc and profile parameter values are dictated by the LSP-EXP mappings of the incoming interface.

When an MPLS echo reply packet is generated in CPM and is forwarded to the outgoing interface, the packet is queued in the egress network queue corresponding to the fc and profile parameter values determined by the classification of the echo request packet, which is being replied to, at the incoming interface. The marking of the packet's EXP is dictated by the LSP-EXP mappings on the outgoing interface. The TOS byte is not modified. The following table summarizes this behavior:

**Table 9: Request Packet and Behavior**

cpm (sender node)	echo request packet: <ul style="list-style-type: none"> <li>packet{tos=1, fc1, profile1}</li> <li>fc1 and profile1 are as entered by user in OAM command or default values</li> <li>tos1 as per mapping of {fc1, profile1} to IP precedence in network egress QoS policy of outgoing interface</li> </ul>
outgoing interface (sender node)	echo request packet: <ul style="list-style-type: none"> <li>pkt queued as {fc1, profile1}</li> <li>ToS field=tos1 not remarked</li> <li>EXP=exp1, as per mapping of {fc1, profile1} to EXP in network egress QoS policy of outgoing interface</li> </ul>
Incoming interface (responder node)	echo request packet: <ul style="list-style-type: none"> <li>packet{tos1, exp1}</li> <li>exp1 mapped to {fc2, profile2} as per classification in network QoS policy of incoming interface</li> </ul>
cpm (responder node)	echo reply packet: <ul style="list-style-type: none"> <li>packet{tos=1, fc2, profile2}</li> </ul>
outgoing interface (responder node)	echo reply packet: <ul style="list-style-type: none"> <li>pkt queued as {fc2, profile2}</li> <li>ToS field= tos1 not remarked (reply inband or out-of-band)</li> <li>EXP=exp2, if reply is inband, remarked as per mapping of {fc2, profile2} to EXP in network egress QoS policy of outgoing interface</li> </ul>
Incoming interface (sender node)	echo reply packet: <ul style="list-style-type: none"> <li>packet{tos1, exp2}</li> <li>exp2 mapped to {fc1, profile1} as per classification in network QoS policy of incoming interface</li> </ul>

**Values** be, l2, af, l1, h2, ef, h1, nc

**Default** be

**profile** {in | out} — The profile state of the MPLS echo request packet.

**Default** out

**path-destination** *ip-address* — Specifies the IP address of the path destination from the range 127/8.

**interface** *interface-name* — Specifies the name of an IP interface. The name must already exist in the con-fig>router>interface context.

## Operational Commands

**downstream-map-tlv** { **dsmap**|**ddmap**|**none** } — Specifies which format of the downstream mapping TLV to use in the LSP trace packet. The DSMAP TLV is the original format in RFC 4379. The DDMAP is the new enhanced format specified in RFC 6424. The user can also choose not to include the downstream mapping TLV by entering the value none.

**Default** Inherited from global configuration of downstream mapping TLV in option **mpls-echo-request-downstream-map** { **dsmap** | **ddmap** }.

### Sample Output

```
*A:Dut-A# oam lsp-trace prefix 10.20.1.6/32 downstream-map-tlv ddmap path-destination
127.0.0.1 detail lsp-trace to 10.20.1.6/32: 0 hops min, 0 hops max, 152 byte packets
1 10.20.1.2 rtt=3.44ms rc=8(DSRtrMatchLabel) rsc=1
   DS 1: ipaddr=127.0.0.1 ifaddr=0 iftype=ipv4Unnumbered MRU=1500
        label[1]=131070 protocol=3(LDP)
2 10.20.1.4 rtt=4.65ms rc=8(DSRtrMatchLabel) rsc=1
   DS 1: ipaddr=127.0.0.1 ifaddr=0 iftype=ipv4Unnumbered MRU=1500
        label[1]=131071 protocol=3(LDP)
3 10.20.1.6 rtt=7.63ms rc=3(EgressRtr) rsc=1 *A:Dut-A#
```

```
*A:Dut-C# oam lsp-trace "p_1" detail
lsp-trace to p_1: 0 hops min, 0 hops max, 116 byte packets
1 10.20.1.2 rtt=3.46ms rc=8(DSRtrMatchLabel)
   DS 1: ipaddr 10.20.1.4 ifaddr 3 iftype 'ipv4Unnumbered' MRU=1500 label=131071
proto=4(RSVP-TE)
2 10.20.1.4 rtt=3.76ms rc=8(DSRtrMatchLabel)
   DS 1: ipaddr 10.20.1.6 ifaddr 3 iftype 'ipv4Unnumbered' MRU=1500 label=131071
proto=4(RSVP-TE)
3 10.20.1.6 rtt=5.68ms rc=3(EgressRtr)
*A:Dut-C#
```

### Isp-trace over a numbered IP interface

```
A:DUTA#
A:DUTA# oam lsp-trace prefix 5.5.5.5/32 detail
lsp-trace to 5.5.5.5/32: 0 hops min, 0 hops max, 104 byte packets
1 6.6.6.6 rtt=2.45ms rc=8(DSRtrMatchLabel)
   DS 1: ipaddr=5.6.5.1 ifaddr=5.6.5.1 iftype=ipv4Numbered MRU=1564 label=131071
proto=3(LDP)
2 5.5.5.5 rtt=4.77ms rc=3(EgressRtr)
A:DUTA#
```

### Isp-trace over an unnumbered IP interface

```
*A:Dut-A# oam lsp-trace prefix 10.20.1.6/32 downstream-map-tlv ddmap path-destination
127.0.0.1 detail lsp-trace to 10.20.1.6/32: 0 hops min, 0 hops max, 152 byte packets
1 10.20.1.2 rtt=3.44ms rc=8(DSRtrMatchLabel) rsc=1
   DS 1: ipaddr=127.0.0.1 ifaddr=0 iftype=ipv4Unnumbered MRU=1500
        label[1]=131070 protocol=3(LDP)
2 10.20.1.4 rtt=4.65ms rc=8(DSRtrMatchLabel) rsc=1
   DS 1: ipaddr=127.0.0.1 ifaddr=0 iftype=ipv4Unnumbered MRU=1500
        label[1]=131071 protocol=3(LDP)
3 10.20.1.6 rtt=7.63ms rc=3(EgressRtr) rsc=1 *A:Dut-A#
```

```
*A:Dut-A# oam ldp-treetrace prefix 10.20.1.6/32
```

```
ldp-treetrace for Prefix 10.20.1.6/32:
```

```
      127.0.0.1, ttl = 3 dst = 127.1.0.255 rc = EgressRtr status = Done  
Hops:      127.0.0.1      127.0.0.1
```

```
      127.0.0.1, ttl = 3 dst = 127.2.0.255 rc = EgressRtr status = Done  
Hops:      127.0.0.1      127.0.0.1
```

```
ldp-treetrace discovery state: Done  
ldp-treetrace discovery status: ' OK '  
Total number of discovered paths: 2  
Total number of failed traces: 0
```

**Values**

**Values**

## EFM Commands

### efm

**Syntax** *port-id*

**Context** oam>efm

**Description** This command enables Ethernet in the First Mile (EFM) OAM tests loopback tests on the specified port. The EFM OAM remote loopback OAMPDU will be sent to the peering device to trigger remote loopback.

**Parameters** *port-id* — Specify the port ID in the slot/mda/port format.

### local-loopback

**Syntax** **local-loopback** {start | stop}

**Context** oam>efm

**Description** This command enables local loopback tests on the specified port.

### remote-loopback

**Syntax** **remote-loopback** {start | stop}

**Context** oam>efm

**Description** This command enables remote Ethernet in the First Mile (EFM) OAM loopback tests on the specified port. The EFM OAM remote loopback OAMPDU will be sent to the peering device to trigger remote loopback.

## ETH-CFM OAM Commands

### linktrace

**Syntax** `linktrace mac-address mep mep-id domain md-index association ma-index [ttl ttl-value]`

**Context** oam>eth-cfm

**Default** The command specifies to initiate a linktrace test.

**Parameters** *mac-address* — Specifies a unicast destination MAC address.

**mep** *mep-id* — Specifies the target MAC address.

**Values** 1 — 8191

**domain** *md-index* — Specifies the MD index.

**Values** 1 — 4294967295

**association** *ma-index* — Specifies the MA index.

**Values** 1 — 4294967295

**ttl** *ttl-value* — Specifies the TTL for a returned linktrace.

**Values** 0 — 255

**Default** 64

### loopback

**Syntax** `loopback mac-address mep mep-id domain md-index association ma-index [send-count send-count] [size data-size] [priority priority]`

**Context** oam>eth-cfm

**Default** The command specifies to initiate a loopback test.

**Parameters** *mac-address* — Specifies a unicast MAC address.

**mep** *mep-id* — Specifies target MAC address.

**Values** 1 — 8191

**domain** *md-index* — Specifies the MD index.

**Values** 1 — 4294967295

**association** *ma-index* — Specifies the MA index.

**Values** 1 — 4294967295

**send-count** *send-count* — Specifies the number of messages to send, expressed as a decimal integer. Loopback messages are sent back to back, with no delay between the transmissions.

## Operational Commands

**Default** 1

**Values** 1 — 5

**size** *data-size* — This is the size of the data portion of the data TLV. If 0 is specified no data TLV is added to the packet.

**Values** 0 — 1500

**priority** *priority* — Specifies a 3-bit value to be used in the VLAN tag, if present, in the transmitted frame.

**Values** 0 — 7

## eth-test

**Syntax** *mac-address mep mep-id domain md-index association ma-index* [**priority** *priority*] [**data-length** *data-length*]

**Context** oam>eth-cfm

**Description** This command issues an ETH-CFM test.

**Parameters** *mac-address* — Specifies a unicast MAC address.

**mep** *mep-id* — Specifies target MAC address.

**Values** 1 — 8191

**domain** *md-index* — Specifies the MD index.

**Values** 1 — 4294967295

**association** *ma-index* — Specifies the MA index.

**Values** 1 — 4294967295

**data-length** *data-length* — Indicates the UDP data length of the echo reply, the length starting after the IP header of the echo reply.

**Values** 64 — 1500

**Default** 64

**priority** *priority* — Specifies the priority.

**Values** 0 — 7

**Default** The CCM and LTM priority of the MEP

## one-way-delay-test

<b>Syntax</b>	<b>one-way-delay-test</b> <i>mac-address</i> <b>mep</b> <i>mep-id</i> <b>domain</b> <i>md-index</i> <b>association</b> <i>ma-index</i> [ <b>priority</b> <i>priority</i> ]
<b>Context</b>	oam>eth-cfm
<b>Description</b>	This command issues an ETH-CFM one-way delay test.
<b>Parameters</b>	<p><i>mac-address</i> — Specifies a unicast MAC address.</p> <p><b>mep</b> <i>mep-id</i> — Specifies target MAC address.</p> <p><b>Values</b> 1 — 8191</p> <p><b>domain</b> <i>md-index</i> — Specifies the MD index.</p> <p><b>Values</b> 1 — 4294967295</p> <p><b>association</b> <i>ma-index</i> — Specifies the MA index.</p> <p><b>Values</b> 1 — 4294967295</p> <p><b>priority</b> <i>priority</i> — Specifies the priority.</p> <p><b>Values</b> 0 — 7</p> <p><b>Default</b> The CCM and LTM priority of the MEP.</p>

## two-way-delay-test

<b>Syntax</b>	<b>two-way-delay-test</b> <i>mac-address</i> <b>mep</b> <i>mep-id</i> <b>domain</b> <i>md-index</i> <b>association</b> <i>ma-index</i> [ <b>priority</b> <i>priority</i> ]
<b>Context</b>	oam>eth-cfm
<b>Description</b>	This command issues an ETH-CFM two-way delay test.
<b>Parameters</b>	<p><i>mac-address</i> — Specifies a unicast MAC address.</p> <p><b>mep</b> <i>mep-id</i> — Specifies target MAC address.</p> <p><b>Values</b> 1 — 8191</p> <p><b>domain</b> <i>md-index</i> — Specifies the MD index.</p> <p><b>Values</b> 1 — 4294967295</p> <p><b>association</b> <i>ma-index</i> — Specifies the MA index.</p> <p><b>Values</b> 1 — 4294967295</p> <p><b>priority</b> <i>priority</i> — Specifies the priority.</p> <p><b>Values</b> 0 — 7</p> <p><b>Default</b> The CCM and LTM priority of the MEP.</p>

## two-way-slm-test

**Syntax** **two-way-slm-test** *mac-address* **mep** *mep-id* **domain** *md-index* **association** *ma-index* [**priority** *priority*] [**send-count** *send-count*] [**size** *data-size*] [**timeout** *timeout*] [**interval** *interval*]

**Context** oam>eth-cfm

**Description** This command configures an Ethernet CFM two-way SLM test in SAA.

*mac-address* — Specifies a unicast destination MAC address.

**mep** *mep-id* — Specifies the target MAC address.

**Values** 1 — 8191

**domain** *md-index* — Specifies the MD index.

**Values** 1 — 4294967295

**association** *ma-index* — Specifies the MA index.

**Values** 1 — 4294967295

**priority** *priority* — Specifies a 3-bit value to be used in the VLAN tag, if present, in the transmitted frame.

**send-count** *send-count* — The number of messages to send, expressed as a decimal integer. The **count** parameter is used to override the default number of message requests sent. Each message request must either timeout or receive a reply before the next message request is sent. The message **interval** value must be expired before the next message request is sent.

**Default** 1

**Values** 1 — 1000

**size** *data-size* — This is the size of the data portion of the data TLV. If 0 is specified no data TLV is added to the packet.

**Default** 0

**Values** 0 — 1500

**timeout** *timeout* — The **timeout** parameter in seconds, expressed as a decimal integer. This value is used to override the default **timeout** value and is the amount of time that the router waits for a reply message after sending the message request. Upon the expiration of message timeout, the requesting router assumes that the message response is not received. Any response received after the request times out is silently discarded.

**Default** 5

**Values** 1 — 10

**interval** *interval* — The **interval** parameter in seconds, expressed as a decimal integer. This parameter is used to override the default request message send interval and defines the minimum amount of time that must expire before the next message request is sent.

If the **interval** is set to 1 second, and the **timeout** value is set to 10 seconds, then the maximum time

between message requests is 10 seconds and the minimum is 1 second. This depends upon the receipt of a message reply corresponding to the outstanding message request.

**Default** 5

**Values** [0.1, 0.2, .. 0.9] | [1, 2, .. 10]

## Testhead Commands

### test-oam

**Syntax** `test-oam`

**Context** `config`

**Description** This command enables the context to configure Operations, Administration, and Maintenance test parameters

### testhead-profile

**Syntax** `testhead-profile profile-id create`

**Context** `config> test-oam`

**Description** Provides the context to the create service testhead profiles which is used by the Y.1564/RFC 2544 testhead (also known as, traffic generator) OAM tool. A service testhead profile allows user to configure the parameters such as contents of the frame payload that is generated by traffic generator, the size of the frame, test duration, test acceptance criteria, and other criteria to be used by the testhead tool.

The profile is used the testhead OAM tool to generate the appropriate frame at the configured rate and measure the performance parameters (FD, FDV, and loss). At the end of the test run, the tool compares the measured values against the test acceptance criteria that is configured in the profile to determine if the service is within bounds of the acceptance criteria or not.

The no form the command removes user created profile from the system.

**Default** none

**Parameters** *profile-id* — Identifies the profile.

**Values** 1-10

### description

**Syntax** `description profile-description`

**Context** `config> test-oam>testhead-profile`

**Description** Allows user to associate a description with profile.  
The no form the command removes description.

**Default** none

**Parameters** *profile-description* — Provides a way to add a description to the profile based on its use or as per user choice.

**Values** ASCII string

## rate

**Syntax** **[no] rate cir-rate-in-kbps [cir-adaptation-rule adaptation-rule] [pir cir-rate-in-kbps]**

**Context** config> test-oam>testhead-profile

**Description** The testhead tool generates traffic up to the configured CIR rate, if the PIR rate is not specified. In other words, CIR rate specifies the bandwidth or throughput the user needs to validate. User can specify the optional PIR rate. If the PIR rate is specified, it needs to be greater than or equal to the CIR rate and the testhead generates traffic up to the configured PIR rate.

The *cir-adaptation-rule* parameter rule can be specified to let the system derive the operational hardware rate for both the CIR and PIR rate. This allows the software to find the best operational rate based on the user specified constraint and the hardware based rate steps supported on the platform. For more information about the hardware rate steps supported for meters on different platforms, see the “7210 SAS QoS User Guide”.

The no form of the command sets the CIR to default and PIR is not set. If the test is run after executing no rate command, the test generates traffic up to CIR rate. If PIR rate is specified, it must be greater than or equal to the CIR rate.

**Default** rate cir 1000kbps adaptation-rule closest

**Parameters** *cir-rate* — The cir parameter overrides the default administrative CIR to use. When the rate command has not been executed or the cir parameter is not explicitly specified, the default CIR is assumed. Fractional values are not allowed and must be given as a positive integer. The actual CIR rate is dependent on the meter’s adaptation-rule parameters and the hardware. It is specified in kilo-bits per second (kbps).

**Values** 0 — 10000000, max

*adaptation-rule* — Defines the constraints enforced when adapting the CIR and PIR rate defined with the rate command to the hardware rates supported by the platform. This parameter requires a qualifier that defines the constraint used when deriving the operational CIR and PIR value. If this parameter is not specified then the default adaptation-rule closest is applied.

**Values** [closest|max|min]

*max* - The max (maximum) option is mutually exclusive with the min and closest options. When max is defined, the operational CIR will be the next multiple of the hardware step-size that is equal to or lesser than the specified rate. The hardware step-size is determined by the configured administrative CIR and varies based on the platform.

*min* - The min (minimum) option is mutually exclusive with the max and closest options. When min is defined, the operational PIR will be the next multiple of the hardware step-size that is equal to or lesser than the specified rate. The hardware step-size is determined by the configured administrative CIR and varies based on the platform.

*closest* - The closest parameter is mutually exclusive with the min and max parameter.

## Operational Commands

When *closest* is defined, the operational CIR will be the next multiple of the hardware step-size that is equal to or lesser than the specified rate. The hardware step-size is determined by the configured administrative CIR and varies based on the platform.

*pir-rate* — The *pir* parameter overrides the default administrative PIR to use. When the *rate* command has not been executed or the PIR parameter is not explicitly specified, the default PIR is assumed. Fractional values are not allowed and must be given as a positive integer. The actual PIR rate is dependent on the meter's adaptation-rule parameters and the hardware. The value is specified in kilo-bits per second (kbps).

**Values** 0 — 10000000, max

## test-duration

**Syntax** `test-duration {[hours hours] [minutes minutes] [seconds seconds]}`

**Context** `config> test-oam>testhead-profile`

**Description** This command allows the user to specify the total test duration to be used for throughput measurement. The CLI parameters, *hours*, *minutes*, and *seconds*, allows the user to specify the number of hours, number of minutes and number of seconds to used for throughput measurement. User can specify all the parameters together. If all the parameters are specified together then the total test duration is set to the sum of the values specified for hours, minutes and seconds.

The no form of the command sets the value to the default value

**Default** no test-duration (sets the test duration for 3 minutes).

**Parameters** *hours* — The total number of hours to run the test. The total test duration is determined by the sum of the hours, minutes and seconds specified by the user.

**Values** 0 - 24

*minutes* — The total number of minutes to run the test. The total test duration is determined by the sum of the hours, minutes and seconds specified by the user.

**Values** 0 — 60

*seconds* — The total number of seconds to run the test. The total test duration is determined by the sum of the hours, minutes and seconds specified by the user.

**Values** 0 — 60

## frame-size

<b>Syntax</b>	<b>[no] frame-size [64..9212]</b>
<b>Context</b>	config> test-oam>testhead-profile
<b>Description</b>	This command allows the user to specify the frame size of the packets generated by the testhead tool. Any frame size in the given range can be specified.  The no form of the command sets the value to the default value
<b>Default</b>	no frame-size - set to a default value of 1514 bytes.
<b>Parameters</b>	<i>frame-size</i> — The size of the frame generated by the testhead tool. Choose from among the value allowed in the available range.  <b>Values</b> 64 ... 9212

## acceptance-criteria

<b>Syntax</b>	<b>[no] acceptance-criteria <i>acceptance-criteria-id</i> create</b>
<b>Context</b>	configure> test-oam> testhead-profile
<b>Description</b>	This command provides the context to specify the test acceptance criteria to be used by the testhead OAM tool to declare the PASS/FAIL result at the completion of the test.  User can create upto 4 different acceptance criteria per profile to measure different SLA needs. User has an option to specify only one of the acceptance criteria to be specified with the testhead OAM tool during the invocation of the test.  The no form of the command removes the test acceptance criteria.
<b>Default</b>	no defaults
<b>Parameters</b>	<i>acceptance-criteria-id</i> — A number to identify the test acceptance criteria. It is a decimal number used to identify the test acceptance criteria and to use when starting the throughput test.  <b>Values</b> 1- 4

## cir-threshold

<b>Syntax</b>	<b>[no] cir-threshold <i>cir-threshold</i></b>
<b>Context</b>	configure> test-oam> testhead-profile> acceptance-criteria
<b>Description</b>	The specified value for the CIR rate is compared with the measured CIR rate at the end of the test to declare the test result. If the measured value is greater than the specified value the test is declared as 'PASS', else it is considered to be 'FAIL'.

## Operational Commands

The no form of the command disables the comparison of the parameter with the measured value at the end of the test. Basically, the threshold value is ignored and not considered for declaring the test result.

**Default** no cir-threshold

**Parameters** *threshold* — Specifies the value for comparison with measured value

**Values** 0 – 1000000kbps

## pir-threshold

**Syntax** **[no]** **pir-threshold** *pir-threshold*

**Context** configure> test-oam> testhead-profile> acceptance-criteria

**Description** The specified value for the PIR rate is compared with the measured PIR rate at the end of the test to declare the test result. If the measured value is greater than the specified value the test is declared as 'PASS', else it is considered to be 'FAIL'.

The no form of the command disables the comparison of the parameter with the measured value at the end of the test. Basically, the threshold value is ignored and not considered for declaring the test result.

**Default** no pir-threshold

**Parameters** *threshold* — Specifies the value for comparison with measured value

**Values** 0 – 1000000kbps

## latency-rising-threshold

**Syntax** **[no]** **latency-rising-threshold** *threshold*

**Context** configure> test-oam> testhead-profile> acceptance-criteria

**Description** The specified value for the latency is compared with the measured latency at the end of the test to declare the test result. If the measured value is greater than the specified value the test is declared as 'FAIL', else it is considered to be 'PASS'.

The no form of the command disables the comparison of the parameter with the measured value at the end of the test. Basically, the threshold value is ignored and not considered for declaring the test result.

**Default** no latency-rising-threshold

**Parameters** *threshold* — Specifies the value for comparison with measured value.

**Values** [0..2147483000], Specified in microseconds.

## latency-rising-threshold-in

<b>Syntax</b>	<b>[no] latency-rising-threshold-in</b> <i>in-profile-threshold</i>
<b>Context</b>	configure> test-oam> testhead-profile> acceptance-criteria
<b>Description</b>	<p>The specified value for the latency is compared with the measured latency for green/in-profile packets at the end of the test to declare the test result. If the measured value is greater than the specified value the test is declared as 'FAIL', else it is considered to be 'PASS'.</p> <p>The no form of the command disables the comparison of the parameter with the measured value at the end of the test. Basically, the threshold value is ignored and not considered for declaring the test result.</p>
<b>Default</b>	no latency-rising-threshold-in
<b>Parameters</b>	<i>In-profile-threshold</i> — Specifies the value for comparison with measured value
<b>Values</b>	[0..2147483000], Specified in microseconds.

## latency-rising-threshold-out

<b>Syntax</b>	<b>[no] latency-rising-threshold out-profile-threshold</b>
<b>Context</b>	configure> test-oam> testhead-profile> acceptance-criteria
<b>Description</b>	<p>The specified value for the latency is compared with the measured latency of yellow or out-of-profile packets at the end of the test to declare the test result. If the measured value is greater than the specified value the test is declared as 'FAIL', else it is considered to be 'PASS'.</p> <p>The no form of the command disables the comparison of the parameter with the measured value at the end of the test. Basically, the threshold value is ignored and not considered for declaring the test result.</p>
<b>Default</b>	no latency-rising-threshold-out
<b>Parameters</b>	<i>out-profile-threshold</i> — Specifies the value for comparison with measured value
<b>Values</b>	[0..2147483000], Specified in microseconds.

## jitter-rising-threshold

<b>Syntax</b>	<b>[no] jitter-rising-threshold</b> <i>threshold</i>
<b>Context</b>	configure> test-oam> testhead-profile> acceptance-criteria
<b>Description</b>	<p>The specified value for the jitter is compared with the measured jitter at the end of the test to declare the test result. If the measured value is greater than the specified value the test is declared as 'FAIL', else it is considered to be 'PASS'.</p> <p>The no form of the command disables the comparison of the parameter with the measured value at the end of the test. Basically, the threshold value is ignored and not considered for declaring the test result.</p>

## Operational Commands

**Default** no jitter-rising-threshold

**Parameters** *threshold* — Specifies the value for comparison with measured value.

**Values** [0..2147483000], Specified in microseconds.

### jitter-rising-threshold-in

**Syntax** [**no**] jitter-rising-threshold-in *in-profile-threshold*

**Context** configure> test-oam> testhead-profile> acceptance-criteria

**Description** The specified value for the jitter is compared with the measured jitter for green/in-profile packets at the end of the test to declare the test result. If the measured value is greater than the specified value the test is declared as 'FAIL', else it is considered to be 'PASS'.

The no form of the command disables the comparison of the parameter with the measured value at the end of the test. Basically, the threshold value is ignored and not considered for declaring the test result.

**Default** no jitter-rising-threshold-in

**Parameters** *In-profile-threshold* — Specifies the value for comparison with measured value

**Values** [0..2147483000], Specified in microseconds.

### jitter-rising-threshold-out

**Syntax** [**no**] jitter-rising-threshold-out *out-profile-threshold*

**Context** configure> test-oam> testhead-profile> acceptance-criteria

**Description** The specified value for the jitter is compared with the measured jitter for yellow/out-of-profile packets at the end of the test to declare the test result. If the measured value is greater than the specified value the test is declared as 'FAIL', else it is considered to be 'PASS'.

The no form of the command disables the comparison of the parameter with the measured value at the end of the test. Basically, the threshold value is ignored and not considered for declaring the test result.

**Default** no jitter-rising-threshold-out

**Parameters** *out-profile-threshold* — Specifies the value for comparison with measured value

**Values** [0..2147483000], Specified in microseconds.

## loss-rising-threshold

<b>Syntax</b>	<b>[no] loss-rising-threshold</b> <i>threshold</i>
<b>Context</b>	configure> test-oam> testhead-profile> acceptance-criteria
<b>Description</b>	<p>The specified value for the Frame Loss Ratio (FLR) is compared with the measured FLR at the end of the test to declare the test result. If the measured value is greater than the specified value the test is declared as 'FAIL', else it is considered to be 'PASS'.</p> <p>Frame Loss Ratio is computed as a ratio of the difference of number of received frames to number of injected or sent frames divided by the number of sent frames.</p> <p>The no form of the command disables the comparison of the parameter with the measured value at the end of the test. Basically, the threshold value is ignored and not considered for declaring the test result.</p>
<b>Default</b>	no loss-rising-threshold
<b>Parameters</b>	<p><i>threshold</i> — Specifies the value for comparison with measured value.</p> <p><b>Values</b> 1 – 1000000, Loss-rising-threshold is specified as a number which denotes one ten-thousandth (1/10000) of a percent. For example, specifying a value of 1 is equivalent to 0.0001%, and specifying a value of 10000 is equivalent to 1%.</p>

## loss-rising-threshold-in

<b>Syntax</b>	<b>[no] loss-rising-threshold-in</b> <i>in-profile-threshold</i>
<b>Context</b>	configure> test-oam> testhead-profile> acceptance-criteria
<b>Description</b>	<p>The specified value for the frame loss ratio (FLR) is compared with the measured FLR for green or in-profile packets at the end of the test to declare the test result. If the measured value is greater than the specified value the test is declared as 'FAIL', else it is considered to be 'PASS'.</p> <p>Frame Loss Ratio for green/in-profile packets is computed as a ratio of the difference of number of received green or in-profile frames to number of injected/sent green/in-profile frames divided by the number of sent green frames.</p> <p>The no form of the command disables the comparison of the parameter with the measured value at the end of the test. Basically, the threshold value is ignored and not considered for declaring the test result.</p>
<b>Default</b>	no loss-rising-threshold-in
<b>Parameters</b>	<p><i>in-profile-threshold</i> — Specifies the value for comparison with measured value</p> <p><b>Values</b> 1 – 1000000, Loss-rising-threshold is specified as a number which denotes one ten-thousandth (1/10000) of a percent. For example, specifying a value of 1 is equivalent to 0.0001%, and specifying a value of 10000 is equivalent to 1%.</p>

## loss-rising-threshold-out

<b>Syntax</b>	<b>[no] loss-rising-threshold-out</b> <i>out-profile-threshold</i>
<b>Context</b>	configure> test-oam> testhead-profile> acceptance-criteria
<b>Description</b>	<p>The specified value for the frame loss ratio (FLR) is compared with the measured FLR for yellow/out-of-profile packets at the end of the test to declare the test result. If the measured value is greater than the specified value the test is declared as 'FAIL', else it is considered to be 'PASS'.</p> <p>Frame Loss ratio for yellow/out-of-profile packets is computed as a ratio of the difference of number of received yellow frames to number of injected/sent yellow frames divided by the number of sent yellow frames.</p> <p>The no form of the command disables the comparison of the parameter with the measured value at the end of the test. Basically, the threshold value is ignored and not considered for declaring the test result.</p>
<b>Default</b>	no loss-rising-threshold
<b>Parameters</b>	<i>out-profile-threshold</i> — Specifies the value for comparison with measured value
<b>Values</b>	1 – 1000000, Loss-rising-threshold is specified as a number which denotes one ten-thousandth (1/10000) of a percent. For example, specifying a value of 1 is equivalent to 0.0001%, and specifying a value of 10000 is equivalent to 1%.

## test-completion-trap-enable

<b>Syntax</b>	<b>[no] test-completion-trap-enable</b>
<b>Context</b>	configure> test-oam> testhead-profile
<b>Description</b>	<p>Executing this command allows the user to specify that the test completion trap needs to be generated after the completion of the test or if the test is stopped. The trap contains the details of test configuration, the measured values, test completion status and PASS/FAIL result.</p> <p>The no form of the command disables the generation of the event/log/trap after test completion.</p>
<b>Default</b>	no test-completion-trap-enable – that is, trap is not generated on completion of the test.

## dot1p

<b>Syntax</b>	<b>[no] dot1p in-profile</b> <i>dot1p-value</i> <b>out-of-profile</b> <i>dot1p-value</i>
<b>Context</b>	configure> test-oam> testhead-profile
<b>Description</b>	<p>This command allows the user to configure the Dot1p values to identify the in-profile or green packets and out-of-profile or yellow packets. The values configured using this command are used by the testhead tool on the local end (that is, the node on which the testhead tool is executed) to match the dot1p values received in the packet header and identify green and yellow packets and appropriately account the packets. These values are used only when the testhead tool is invoked with the parameter <i>color-aware</i> is set to 'enable'.</p>

The dot1p in-profile value (that is, packets with dot1p values in the L2 header equal to the dot1p-in-profile value configured is considered to be in-profile or green packet) is used to count the number of in-profile packets and measure the latency, jitter, and FLR for in-profile packets. Similarly, the dot1p out-profile is used to count the total out-of-profile or yellow packets and measure latency, jitter, and FLR for out-of-profile or yellow packets.

While the testhead tool is initiated, if color-aware is set to enable and no values are specified (that is, the no form of the command is used in the profile), the CLI gives an error. If values are specified, then the configured values are used to match and identify in-profile and out-of-profile packets.

The no form of the command disables the use of dot1p to identify a green or yellow packet.

**Note:** Testhead OAM tool does not mark the packets below CIR as in-profile packets and packets above CIR and below PIR as out-of-profile packets using the Dot1p or DSCP or other packet header bits to indicate the color of the packet (for example: DEI bit), as the 7210 SAS access SAP ingress does not support color-aware metering. It is used to only identify green and yellow packets and maintain a count of received green and yellow packets when the tests are run in color-aware mode.

**Default** The no form of this command is the default. There are no defaults for the dot1p values.

**Parameters** *in-profile dot1p-value* — Specifies the dot1p value used to identify green or in-profile packets. It must be different than the value configured for yellow or out-of-profile packets.

**Values** 0-7

*out-profile dot1p-value* — Specifies the dot1p value used to identify green or out-of-profile packets. It must be different than the value configured for green or in-profile packets.

**Values** 0-7

## frame-payload

**Syntax** **[no] frame-payload** *frame-payload-id* [**payload-type** [I2|tcp-ipv4|udp-ipv4|ipv4] **create**

**Context** configure> test-oam> testhead-profile

**Description** This command provides the context to specify the packet header values to be used in frames generated by testhead tool.

User can create up to 4 different types of frame payload representing different kinds of traffic, within a profile. User chooses one among these when starting the throughput test.

The parameter payload-type determines the packet header fields that are used to populate the frame generated by the testhead OAM tool. The packet header fields use the value from the parameters configured under the frame-payload. For example, when the payload-type is configured as "I2", software uses the parameters src-mac, dst-mac, vlan-tag-1 (if configured), vlan-tag-2 (if configured), ethertype, and data-pattern. See below for parameters used when other values are specified with payload-type.

The no form of the command removes the frame payload context.

**Default** no defaults – no frame payload is created by default.

## Operational Commands

**Parameters** *frame-payload-id* — A number to identify the frame-payload. it is an integer used to identify the frame type to use when starting the throughput test.

**Values** 1-4

*frame-payload-type* — Identifies whether the frame payload is L2 traffic, IP traffic, TCP/IP traffic or UDP/IP traffic and uses appropriate parameters to build the frame to be generated by the testhead OAM tool. It defaults to tcp-ipv4, if the user does not specify the value during creation of the new frame-payload.

**Values** l2|tcp-ipv4|udp-ipv4|ipv4  
If l2 is specified, use src-mac+dst-mac+vlan-tag-1(if available)+vlan-tag-2 (if available)+ethertype+data-pattern.  
If tcp-ipv4 or udp-ipv4 is specified, use src-mac+dst-mac+vlan-tag-1(if available)+vlan-tag-2 (if available)+ethertype=0x0800+src-ipv4+dst-ipv4+ip-ttl+ip-dscp or ip-tos+TCP/UDP Protocol Number+src-port+dst-port+data-pattern.  
If ipv4 is specified, use src-mac+dst-mac+vlan-tag-1(if available)+vlan-tag-2 (if available)+ethertype=0x0800+src-ipv4+dst-ipv4+ip-ttl+ip-dscp or ip-tos+ip-proto+data-pattern.

## description

**Syntax** [no] **description** *frame-description*

**Context** configure> test-oam> testhead-profile> frame-payload

**Description** This command allows user to add some description to the frame type created to describe the purpose or identify the usage or any other such purpose.

The no form of the command removes the description.

**Default** no description

**Parameters** *frame-description* — it is an ASCII string used to describe the frame.

**Values** ASCII string

## src-mac

**Syntax** [no] **src-mac** *mac-address*

**Context** configure> test-oam> testhead-profile> frame-payload

**Description** Specifies the value of source MAC address to use in the frame generated by the testhead OAM tool. Only unicast MAC address must be specified.

This value must be specified for all possible values of payload-type.

The no form of the command indicates that the field is not to be used in the frame generated by the tool.

**Default** no src-mac

**Parameters** *mac-address* — Specify the unicast source MAC address.

**Values** It is specified as a hexadecimal string using the notation xx:xx:xx:xx:xx:xx. The values for xx can be in the range 0-9 and a-f.

## dst-mac

**Syntax** **[no] dst-mac** *mac-address*

**Context** configure> test-oam> testhead-profile> frame-payload

**Description** Specifies the value of source MAC address to use in the frame generated by the testhead OAM tool. Only unicast MAC address must be specified.

This value must be specified for all possible values of payload-type.

The no form of the command indicates that the field is not to be used in the frame generated by the tool.

**Default** no dst-mac

**Parameters** *mac-address* — Specify the unicast source MAC address.

**Values** It is specified as a hexadecimal string using the notation xx:xx:xx:xx:xx:xx. The values for xx can be in the range 0-9 and a-f.

## vlan-tag-1

**Syntax** **[no] vlan-tag-1** **vlan-id** *vlan-id-value* **[tpid** *tpid value* **]** **[dot1p** *dot1p-value* **]**

**Context** configure> test-oam> testhead-profile> frame-payload

**Description** This command allows the user to specify the values to be used for the outermost vlan-tag (often called the outer vlan) in the frame generated by the testhead OAM tool. The tool uses the values specified for VLAN ID, dot1p bits and TPID in populating the outermost VLAN tag in the frame generated.

Configuration of this parameter is optional and it is used for all possible values of payload-type, if configured.

The no form of the command indicates that the field is not to be used in the frame generated by the tool.

NOTES:

- User must ensure that TPID/ethertype configured with this command matches the QinQ ethertype value in use on the port on which the test SAP is configured or must match 0x8100 if the test SAP is configured on a Dot1q encapsulation port, for the frame generated by the tool to be processed successfully on SAP ingress. If this value does not match the one configured under the port, frames generated by the testhead will be dropped by the node on SAP ingress due to ethertype mismatch.
- User must ensure that VLAN ID configured with this command matches the outermost VLAN tag of the QinQ SAP or the Dot1q SAP used for the test SAP for the frame generated by the tool to be processed successfully on SAP ingress. If this value does not match the one configured for the SAP,

## Operational Commands

frames generated by the testhead will be dropped by the node on SAP ingress due to VLAN ID mismatch.

- The Dot1p bits specified for the outermost tag can be used for SAP ingress QoS classification.

**Default** no vlan-tag-1

**Parameters** *vlan-id-value* — Specify the VLAN ID to use to populate the VLAN ID value of the VLAN tag. No defaults are chosen and user has to specify a value to use, if they configure this command.

**Values** Values can be in the range 0-4094.

*tpid-value* — Specify the TPID (also known as, ethertype) to use for the VLAN tag addition. It defaults to 0x8100 if user does not specify it.

**Values** Values can be any of the valid ethertype values allowed for use with VLAN tags in the range 0x0600..0xffff.

*Dot1p-value* — Specify the Dot1p value to use to populate the Dot1p bits in the VLAN tag. It defaults to 0, if the user does not specify it.

**Values** Values can be in the range of 0 – 7.

## vlan-tag-2

**Syntax** **[no] vlan-tag-2 vlan-id *vlan-id-value* [tpid *tpid value*] [dot1p *dot1p-value*]**

**Context** configure> test-oam> testhead-profile> frame-payload

**Description** This command allows the user to specify the values to be used for the second vlan-tag (often called the inner vlan or the C-vlan) in the frame generated by the testhead OAM tool. The tool uses the values specified for VLAN ID, dot1p bits and TPID in populating the second VLAN tag in the frame generated.

Configuration of this parameter is optional and it is used for all possible values of payload-type, if configured.

The no form of the command indicates that the field is not to be used in the frame generated by the tool.

### NOTES:

- User must ensure that TPID/ethertype configured with this command is 0x8100 for the frame generated by the tool to be processed successfully on SAP ingress. If this value does not match 0x8100, frames generated by the testhead will be dropped by the node on SAP ingress due to ethertype mismatch (7210 supports only 0x8100 as the ethertype value for the inner vlan tag).
- User must ensure that VLAN ID configured with this command matches the outermost VLAN tag of the QinQ SAP or the Dot1q SAP used for the test SAP for the frame generated by the tool to be processed successfully on SAP ingress. If this value does not match the one configured for the SAP, frames generated by the testhead will be dropped by the node on SAP ingress due to VLAN ID mismatch.
- The Dot1p bits specified for the outermost tag can be used for SAP ingress QoS classification.

**Default** no vlan-tag-2

**Parameters** *vlan-id-value* — Specify the VLAN ID to use to populate the VLAN ID value of the VLAN tag. No defaults are chosen and user has to specify a value to use, if they configure this command.

**Values** Values can be in the range 0-4094.

*tpid-value* — Specify the TPID (also known as, ether-type) to use for the VLAN tag addition. It defaults to 0x8100 if user does not specify it.

**Values** Values can be any of the valid ether-type values allowed for use with VLAN tags in the range 0x0600..0xffff.

*Dot1p-value* — Specify the Dot1p value to use to populate the Dot1p bits in the VLAN tag. It defaults to 0, if the user does not specify it.

**Values** Values can be in the range of 0 – 7

## ether-type

**Syntax** **[no] ether-type ether-type-value**

**Context** configure> test-oam> testhead-profile> frame-payload

**Description** This command allows the user to specify the ether-type of the frame generated by the testhead tool.

This value must be specified if the payload-type is “12”. The testhead tool uses the value specified with this command only if the payload-type is “12”. For all other values of payload-type, the ether-type value used in the frame generated by the testhead tool uses specific value based on the payload-type. See the frame-payload CLI description for more information.

The no form of the command indicates that the field is not to be used in the frame generated by the tool.

**Default** no ether-type, if the payload-type is set to 12, else the values used depends on the payload-type specified.

**Parameters** *ether-type-value* — Specify the frame payload ether-type value.

**Values** Valid ether-type values specified in the range 0x0600..0xffff, as hexadecimal string.

## src-ip

**Syntax** **[no] src-ip ipv4 ipv4-address**

**Context** configure> test-oam> testhead-profile> frame-payload

**Description** This command allows the user to specify the source IPv4 address to use in the IP header for the frame generated by the testhead tool.

This value must be specified if the payload-type is configured as ipv4 or tcp-ipv4 or udp-ipv4. The testhead tool does not use the value specified with this command if the payload-type is “12”.

The no form of the command indicates that the field is not to be used in the frame generated by the tool.

**Default** no src-ip, if the payload-type is set to ipv4, tcp-ipv4, udp-ipv4.

## Operational Commands

**Parameters** *ipv4-address* — Specify the IPv4 source IP address to use in the IP header

**Values** Valid IPv4 address specified in dotted decimal format (that is, a.b.c.d) where a, b, c, d are decimal values in the range 1-255

### dst-ip

**Syntax** **[no] dst-ip ipv4** *ipv4-address*

**Context** configure> test-oam> testhead-profile> frame-payload

**Description** This command allows the user to specify the destination IPv4 address to use in the IP header for the frame generated by the testhead tool.

This value must be specified if the payload-type is configured as ipv4 or tcp-ipv4 or udp-ipv4. The testhead tool does not use the value specified with this command if the payload-type is “12”.

The no form of the command indicates that the field is not to be used in the frame generated by the tool.

**Default** no dst-ip, if the payload-type is set to ipv4, tcp-ipv4, udp-ipv4.

**Parameters** *ipv4-address* — Specify the IPv4 destination IP address to use in the IP header

**Values** Valid IPv4 address specified in dotted decimal format (that is, a.b.c.d) where a, b, c, d are decimal values in the range 1-255.

### ip-proto

**Syntax** **[no] ip-proto** *ip-protocol-number*

**Context** configure> test-oam> testhead-profile> frame-payload

**Description** This command allows the user to specify the IP protocol value to use in the IP header for the frame payload generated by the testhead tool.

This value must be specified if the payload-type is configured as ipv4. If the payload-type is specified as tcp-ipv4 or udp-ipv4, the appropriate standard defined values are used. The testhead tool does not use the value specified with this command if the payload-type is “12”.

The no form of the command indicates that the field is not to be used in the frame generated by the tool.

**Default** no ip-proto

**Parameters** *ip-protocol-number* — Specify the IP-protocol number to use in the IP header.

**Values** Valid IP protocol number specified as a decimal number in the range 0-255.

## dscp

**Syntax** [no] dscp *dscp-name*

**Context** configure> test-oam> testhead-profile> frame-payload

**Description** This command allows the user to specify the IP DSCP value to use in the IP header for the frame generated by the testhead tool.

This value can be specified if the payload-type is configured as ipv4 or tcp-ipv4 or udp-ipv4 and if configured is used by the testhead tool to populate the IP DSCP field of the IP header. If it is not specified it defaults to 0 when the payload type is ipv4, tcp-ipv4, and udp-ipv4. The testhead tool does not use the value specified with this command if the payload-type is "l2".

**NOTES:**

- If both IP DSCP and IP ToS is configured them IP DSCP take precedence.
- If IP DSCP is not configured but IP ToS is configured, then IP ToS value is used.

The no form of the command indicates that the field is not to be used in the frame generated by the tool.

**Default** no dscp

**Parameters** *dscp-name* — Specify the IPv4 DSCP value to use in the IP header.

**Values** Valid values from the list of DSCP names.  
 be|ef|cp1|cp2|cp3|cp4|cp5|cp6|cp7|cp9|cs1|cs2|cs3|cs4|cs5|nc1|nc2|af11|af12|af13|af21|af22|af23|af31|af32|af33|af41|af42|af43|cp11|cp13|cp15|cp17|cp19|cp21|cp23|cp25|cp27|cp29|cp31|cp33|cp35|cp37|cp39|cp41|cp42|cp43|cp44|cp45|cp47|cp49|cp50|cp51|cp52|cp53|cp54|cp55|cp57|cp58|cp59|cp60|cp61|cp62|cp63

## ip-ttl

**Syntax** [no] ip-ttl *ttl-value*

**Context** configure> test-oam> testhead-profile> frame-payload

**Description** This command allows the user to specify the IP TTL (Time-to-Live) value to use in the IP header for the frame generated by the testhead tool.

This value can be specified if the payload-type is configured as ipv4 or tcp-ipv4 or udp-ipv4 and if configured is used by the testhead tool to populate the IP TTL field of the IP header. If it is not specified it defaults to 1 when the payload type is ipv4, tcp-ipv4, and udp-ipv4. The testhead tool does not use the value specified with this command if the payload-type is "l2".

The no form of the command indicates that the field is not to be used in the frame generated by the tool.

**Default** no ip-ttl

**Parameters** *ttl-value* — Specify the IP TTL value to use in the IP header.

**Values** Specified as a decimal number in the range 1-255.

### ip-tos

**Syntax** [no] ip-tos *type-of-service*

**Context** configure> test-oam> testhead-profile> frame-payload

**Description** This command allows the user to specify the IP TOS (Type of Service) value to use in the IP header for the frame generated by the testhead tool.

This value can be specified if the payload-type is configured as ipv4 or tcp-ipv4 or udp-ipv4 and if configured is used by the testhead tool to populate the IP TOS field of the IP header. If it is not specified it defaults to 0 when the payload type is ipv4, tcp-ipv4, and udp-ipv4. The testhead tool does not use the value specified with this command if the payload-type is "l2".

**NOTES:**

- If both IP DSCP and IP ToS is configured them IP DSCP take precedence.
- If IP DSCP is not configured but IP ToS is configured, then IP ToS value is used.

The no form of the command indicates that the field is not to be used in the frame generated by the tool.

**Default** no ip-tos

**Parameters** *type-of-service* — Specify the value of ToS bits to use in the IP header.

**Values** Valid number in the range 0-8.

### src-port

**Syntax** [no] src-port *src-port-number*

**Context** configure> test-oam> testhead-profile> frame-payload

**Description** This command allows the user to specify the source port to use in the TCP header for the frame generated by the testhead tool.

This value must be specified if the payload-type is configured as tcp-ipv4 or udp-ipv4. The testhead tool does not use the value specified with this command if the payload-type is l2 or ipv4.

The no form of the command indicates that the field is not to be used in the frame generated by the tool.

**Default** no src-port, if the payload-type is set to tcp-ipv4 or udp-ipv4

**Parameters** *src-port-number* — Specify the source TCP/UDP port number to use in the frame's TCP/UDP header.

**Values** Valid TCP/UDP port number specified in decimal or hexadecimal in the range 0-65535.

## dst-port

<b>Syntax</b>	<b>[no] dst-port</b>
<b>Context</b>	configure> test-oam> testhead-profile> frame-payload
<b>Description</b>	<p>This command allows the user to specify the destination port to use in the TCP header for the frame generated by the testhead tool.</p> <p>This value must be specified if the payload-type is configured as tcp-ipv4 or udp-ipv4. The testhead tool does not use the value specified with this command if the payload-type is l2 or ipv4.</p> <p>The no form of the command indicates that the field is not to be used in the frame generated by the tool.</p>
<b>Default</b>	no dst-port, if the payload-type is set to tcp-ipv4 or udp-ipv4
<b>Parameters</b>	<p><i>dst-port-number</i> — Specify the destination TCP/UDP port number to use in the frame's TCP/UDP header.</p> <p><b>Values</b> Valid TCP/UDP port number specified in decimal or hexadecimal in the range 0-65535.</p>

## data-pattern

<b>Syntax</b>	<b>[no] data-pattern <i>data-pattern</i></b>
<b>Context</b>	configure> test-oam> testhead-profile> frame-payload
<b>Description</b>	<p>This command allows the user to specify the data pattern to populate the payload portion of the frame generated by the testhead tool.</p> <p>This value can be specified if the payload-type is configured as l2 or ipv4 or tcp-ipv4 or udp-ipv4. For all these payload types, the frame with the appropriate headers is created and the payload portion of the frame, is filled up with the data-pattern-value specified with this command, repeating it as many times as required to fill up the remaining length of the payload.</p> <p>The no form of the command uses the default data-pattern value of 0xa1b2c3d4e5f6.</p>
<b>Default</b>	no data-pattern
<b>Parameters</b>	<p><i>data-pattern</i> — Used to specify the data-pattern to fill the payload data.</p> <p><b>Values</b> A string of decimal or hexadecimal numbers of length in the range 1-64.</p>

---

## OAM testhead commands

### testhead

**Syntax** `testhead test-name owner owner-name testhead-profile profile-id [frame-payload frame-payload-id] [acceptance-criteria acceptance-criteria-id] [color-aware enable|disable] sap sap-id [fc fc-name]`

**Context** oam

**Description** **Platforms Supported:** 7210 SAS-D and 7210 SAS-K.

This command allows the user to execute the throughput test by generating the traffic up to the configured rate and measures the delay, delay-variation and frame-loss ratio. At the end of the test run the testhead command compares the measured values against the test acceptance criteria that is specified to determine if the service is within bounds of the acceptance criteria or not. It declares the test to have PASSED if the configured rate thresholds are achieved and the measured performance parameters (that is, latency, jitter, and FLR) values are lesser than the thresholds configured in the acceptance criteria. It reports a FAILURE, if the configured rate thresholds are not achieved or if any of the measured values for the performance parameters exceeds the thresholds configured in the acceptance criteria. For 7210 SAS-D, both CIR and or PIR can be specified. For 7210 SAS-K only CIR must be specified (PIR is not supported on 7210 SAS-K).

The user must specify the testhead-profile parameter to use. This profile parameter determines the rate at which traffic is generated and the content of the frames used for traffic generation. If both CIR and PIR is specified or if only PIR is specified (by setting CIR to zero), the tool generates traffic up to the configured PIR rate. If only CIR is specified the tool generates traffic up to the configured CIR rate.

If the acceptance-criteria parameter is not specified and color-aware is set to disable, then by default software will display the test result as "PASS", if the frame loss is zero and desired rate is achieved. For comparison with measured rate, the test uses the configured CIR rate, if only CIR is configured or it uses the PIR rate, if either only PIR rate is specified or if both CIR and PIR rates are set to non-zero values. Measured value of latency, jitter and delay variation is not compared.

If the acceptance-criteria parameter is not specified and color-aware is set to enable, then the test is declared to be pass, if the measured CIR and PIR rates matches the configured CIR and PIR values and frame loss is zero OR if one of the following is true:

- If the measured throughput rate (CIR + PIR) is equal to the configured CIR rate and if no PIR rate is configured.
- If the measured throughput rate (CIR + PIR) is equal to the configured PIR rate and if either no CIR rate is configured or if CIR rate is configured.

The test is declared to 'FAIL' otherwise. Measured value of latency, jitter, and delay variation is not compared.

If acceptance-criteria is specified and color-aware is set to enable, the test will use the configured packet header marking values (that is, dot1p) to identify the color of the packet and classify it as green (in-profile) or yellow (out-of-profile). It measures the green packet (that is, CIR rate) and the green/in-profile packet performance parameter values and the yellow packet rate (that is, PIR rate) and the yellow/out-of-profile packet performance parameter values individually based on the packet markings. In addition to comparing the measured performance parameter values against the normal performance parameter threshold values (if

enabled), if user has enabled in/out thresholds for performance parameters in the acceptance-criteria, the tool will use these values to compare against the measured values and declare a pass/fail result. The tool uses the *cir-threshold* and *pir-threshold* to compare against the measured CIR and PIR throughput rates and declare PASS/FAIL, if the thresholds specified by the *cir-threshold* and *pir-threshold* are achieved.

**NOTE:** When color-aware mode is set to enable, the marking values used to identify both in-profile/green packet and out-of-profile/yellow packet must be configured. If either of the packet header marking values (For example: dot1p) are not configured by the user, then the CLI displays an error.

If acceptance-criteria is specified and color-aware is set to disable, the tests are color blind (not color-aware). The tool does not use the configured packet header marking values to identify the color of the packet and treats all packets the same. The tool uses the normal thresholds configured in the acceptance-criteria (i.e. the threshold values other than the in/out profile thresholds) to compare the measured values and declare a pass/fail result. The tool will not make any attempt to compare the in/out thresholds against measured values. The tool uses the *cir-threshold* and *pir-threshold* as follows:

- If no PIR rate is configured and if the measured throughput rate is equal to the configured *cir-threshold* rate, the desired rate is said to have been achieved and the tests continue to compare the measured performance parameter thresholds with the configured performance parameter thresholds (if any).
- If PIR rate is configured and no CIR rate is configured and if the measured throughput rate is equal to the configured *pir-threshold* rate, the desired rate is said to have been achieved and the tests continue to compare the measured performance parameter thresholds with the configured performance parameter thresholds (if any).
- If PIR rate is configured and CIR rate is configured and if the measured throughput rate is equal to the configured *pir-threshold* rate, the desired rate is said to have been achieved and the tests continue to compare the measured performance parameter thresholds with the configured performance parameter thresholds (if any).

The test-name and owner-name together identify a particular testhead invocation/session uniquely. The results of the testhead session are associated with the test-name and owner-name. These parameters must be used if the user needs to display the results of the testhead tool and to clear the results of a completed run. Multiple invocations of the testhead tool with the same test-name and owner-name is not allowed if the results of the old run using the same pair of test-name and owner-name are present. In other words, the results are not overwritten when the testhead is invoked again with the same values for test-name and owner-name. The results needs to be cleared explicitly using the clear command before invoking the testhead tool with the same test-name and owner-name. Results for up to 100 unique sessions each using a different test-name and owner-name is saved in memory (in other words, the results are not available for use after a reboot).

**NOTES:**

- This command is not saved in the configuration file across a reboot
- 7210 SAS-K supports generation of multiple streams of traffic using the testhead OAM tool. The user can run multiple testhead sessions in 7210 SAS-K devices simultaneously to validate multiple SAPs. The total throughput that can be generated is up to about 1Gbps. In other words, the total traffic generated across all the streams is about 1Gbps.

For more information, See the, “Pre-requisites for using the Testhead Tool on page 98”

**Default** no defaults

## OAM testhead commands

### Parameters

*test-name* — Name of the test

**Values** ASCII string upto 32 characters in length

*owner test-owner* — Specifies the owner of an testhead operation.

**Values** ASCII string upto 32 characters in length

*testhead-profile profile-id* — Specifies the testhead profile ID to use with this run/session of testhead invocation. Testhead profile must be configured beforehand using the commands under `config> test-oam> test-head-profile>`.

**Values** 1- 10

*frame-payload frame-payload-id* — Optional parameter used to specify the frame payload ID to use for this run. It identifies the parameters used to construct the frame generated by the testhead tool.

**Values** 1 – 4, if this parameter is not specified, then by default parameters configured under `frame-payload-id 1` is used by this run.

*acceptance-criteria acceptance-criteria-id* — Optional parameter used to specify the test acceptance criteria parameters to use. for this run. It identifies the parameters used to compare the measured performance values against the configured thresholds configured in the acceptance criteria.

**Values** 1 – 4. If this parameter is not specified then the run is declared pass if the throughput configured in the testhead-profile is achieved without any loss.

*color-aware* — Optional parameter that specifies if color aware tests need to be executed. If set to enable, then color-aware test enabled. If set to disable, which is the default, then non-color-ware test is enabled.

*sap sap-id* — Identifies the test SAP. Must be specified by the user.

**Values** null - <port-id|lag-id>  
dot1q - <port-id|lag-id>:qtag1  
qinq - <port-id|lag-id>:qtag1.qtag2  
port-id - slot/mda/port  
lag-id - lag-<id>  
lag - keyword  
id - [1..200]  
qtag1 - [0..4094]  
qtag2 - [\*]1..4094

For more information, see “SAP configuration guidelines”.

*fc fc-name* — Optional parameter that specifies the forwarding class (FC) to use to send the frames generated by the testhead tool.

**Values** be, l2, af, l1, h2, ef, h1, nc

## testhead

**Syntax** `testhead test-name owner owner-name stop`

**Context** oam

**Description** The currently running test, if any will be stopped. All performance results based on the data available upto the time the test is stopped is used determine the pass/fail criteria. Additionally, the test-status will display “Stopped” and Test completion status will be marked “Incomplete or No”.

**Parameters** *test-name* — Name of the test

**Values** ASCII string upto 32 characters in length

*owner test-owner* — Specifies the owner of an testhead operation.

**Values** ASCII string upto 32 characters in length

---

## Service Assurance Agent (SAA) Commands

### saa

**Syntax**    **saa**

**Context**    config

**Description**    This command creates the context to configure the Service Assurance Agent (SAA) tests.

### test

**Syntax**    **test** *name* [**owner** *test-owner*]  
**no test** *name*

**Context**    config>saa

**Description**    This command identifies a test and create/modify the context to provide the test parameters for the named test. Subsequent to the creation of the test instance the test can be started in the OAM context.

A test can only be modified while it is shut down.

The **no** form of this command removes the test from the configuration. In order to remove a test it can not be active at the time.

**Parameters**    *name* — Identify the saa test name to be created or edited.

**owner** *test-owner* — Specifies the owner of an SAA operation upto 32 characters in length.

**Values**        If a *test-owner* value is not specified, tests created by the CLI have a default owner "TIMOS CLI".

### accounting-policy

**Syntax**    **accounting-policy** *acct-policy-id*  
**no accounting-policy**

**Context**    config>saa>test

**Description**    This command associates an accounting policy to the SAA test. The accounting policy must already be defined before it can be associated else an error message is generated.

A notification (trap) when a test is completed is issued whenever a test terminates.

The **no** form of this command removes the accounting policy association.

**Default**    none

**Parameters** *acct-policy-id* — Enter the accounting *policy-id* as configured in the **config>log>accounting-policy** context.

**Values** 1 — 99

## description

**Syntax** **description** *description-string*  
**no description**

**Context** config>saa>test

**Description** This command creates a text description stored in the configuration file for a configuration context. The **description** command associates a text string with a configuration context to help identify the content in the configuration file. The **no** form of this command removes the string from the configuration.

**Default** No description associated with the configuration context.

**Parameters** *string* — The description character string. Allowed values are any string up to 80 characters long composed of printable, 7-bit ASCII characters. If the string contains special characters (#, \$, spaces, etc.), the entire string must be enclosed within double quotes.

## continuous

**Syntax** [**no**] **continuous**

**Context** config>saa>test

**Description** This command specifies whether the SAA test is continuous. Once the test is configured as continuous, it cannot be started or stopped by using the **saa** command. The **no** form of the command disables the continuous running of the test. Use the **shutdown** command to disable the test.

## jitter-event

**Syntax** **jitter-event rising-threshold** *threshold* [**falling-threshold** *threshold*] [**direction**]  
**no jitter-event**

**Context** config>saa>test

**Description** Specifies that at the termination of an SAA test probe, the calculated jitter value is evaluated against the configured rising and falling jitter thresholds. SAA threshold events are generated as required. Once the threshold (rising/falling) is crossed, it is disabled from generating additional events until the opposite threshold is crossed. If a falling-threshold is not supplied, the rising threshold will be re-enabled when it falls below the threshold after the initial crossing that generate the event.

## OAM testhead commands

The configuration of jitter event thresholds is optional.

<b>Parameters</b>	<b>rising-threshold</b> <i>threshold</i> — Specifies a rising threshold jitter value. When the test run is completed, the calculated jitter value is compared to the configured jitter rising threshold. If the test run jitter value is greater than the configured rising threshold value then an SAA threshold event is generated. The SAA threshold event is <code>tmnxOamSaaThreshold</code> , logger application OAM, event #2101.
	<b>Default</b> 0
	<b>Values</b> 0 — 2147483 milliseconds
	<b>falling-threshold</b> <i>threshold</i> — Specifies a falling threshold jitter value. When the test run is completed, the calculated jitter value is compared to the configured jitter falling threshold. If the test run jitter value is greater than the configured falling threshold value then an SAA threshold event is generated. The SAA threshold event is <code>tmnxOamSaaThreshold</code> , logger application OAM, event #2101.
	<b>Default</b> 0
	<b>Values</b> 0 — 2147483 milliseconds
	<i>direction</i> — Specifies the direction for OAM ping responses received for an OAM ping test run.
	<b>Values</b> <b>inbound</b> — Monitor the value of jitter calculated for the inbound, one-way, OAM ping responses received for an OAM ping test run. <b>outbound</b> — Monitor the value of jitter calculated for the outbound, one-way, OAM ping requests sent for an OAM ping test run. <b>roundtrip</b> — Monitor the value of jitter calculated for the round trip, two-way, OAM ping requests and replies for an OAM ping test run.
	<b>Default</b> roundtrip

## latency-event

<b>Syntax</b>	<b>latency-event rising-threshold</b> <i>threshold</i> [ <b>falling-threshold</b> <i>threshold</i> ] [ <b>direction</b> ] <b>no latency-event</b>
<b>Context</b>	config>saa>test
<b>Description</b>	Specifies that at the termination of an SAA test probe, the calculated latency event value is evaluated against the configured rising and falling latency event thresholds. SAA threshold events are generated as required.  Once the threshold (rising/falling) is crossed, it is disabled from generating additional events until the opposite threshold is crossed. If a falling-threshold is not supplied, the rising threshold will be re-enabled when it falls below the threshold after the initial crossing that generate the event.  The configuration of latency event thresholds is optional.
<b>Parameters</b>	<b>rising-threshold</b> <i>threshold</i> — Specifies a rising threshold latency value. When the test run is completed, the calculated latency value is compared to the configured latency rising threshold. If the test run latency value is greater than the configured rising threshold value then an SAA threshold event is generated. The SAA threshold event is <code>tmnxOamSaaThreshold</code> , logger application OAM, event #2101.
	<b>Default</b> 0
	<b>Values</b> 0 — 2147483 milliseconds

**falling-threshold** *threshold* — Specifies a falling threshold latency value. When the test run is completed, the calculated latency value is compared to the configured latency falling threshold. If the test run latency value is greater than the configured falling threshold value then an SAA threshold event is generated. The SAA threshold event is `tmnxOamSaaThreshold`, logger application OAM, event #2101.

**Default** 0

**Values** 0 — 2147483 milliseconds

*direction* — Specifies the direction for OAM ping responses received for an OAM ping test run.

**Values** **inbound** — Monitor the value of jitter calculated for the inbound, one-way, OAM ping responses received for an OAM ping test run.

**outbound** — Monitor the value of jitter calculated for the outbound, one-way, OAM ping requests sent for an OAM ping test run.

**roundtrip** — Monitor the value of jitter calculated for the round trip, two-way, OAM ping requests and replies for an OAM ping test run.

**Default** roundtrip

## loss-event

**Syntax** **loss-event rising-threshold** *threshold* [**falling-threshold** *threshold*] [**direction**]  
**no loss-event**

**Context** config>saa>test

**Description** Specifies that at the termination of an SAA testrun, the calculated loss event value is evaluated against the configured rising and falling loss event thresholds. SAA threshold events are generated as required.

The configuration of loss event thresholds is optional.

**Parameters** **rising-threshold** *threshold* — Specifies a rising threshold loss event value. When the test run is completed, the calculated loss event value is compared to the configured loss event rising threshold. If the test run loss event value is greater than the configured rising threshold value then an SAA threshold event is generated. The SAA threshold event is `tmnxOamSaaThreshold`, logger application OAM, event #2101.

**Default** 0

**Values** 0 — 2147483647 packets

**falling-threshold** *threshold* — Specifies a falling threshold loss event value. When the test run is completed, the calculated loss event value is compared to the configured loss event falling threshold. If the test run loss event value is greater than the configured falling threshold value then an SAA threshold event is generated. The SAA threshold event is `tmnxOamSaaThreshold`, logger application OAM, event #2101.

**Default** 0

**Values** 0 — 2147483647 packets

*direction* — Specifies the direction for OAM ping responses received for an OAM ping test run.

**Values** **inbound** — Monitor the value of jitter calculated for the inbound, one-way, OAM ping responses received for an OAM ping test run.

## OAM testhead commands

**outbound** — Monitor the value of jitter calculated for the outbound, one-way, OAM ping requests sent for an OAM ping test run.

**roundtrip** — Monitor the value of jitter calculated for the round trip, two-way, OAM ping requests and replies for an OAM ping test run.

**Default** roundtrip

## probe-history

**Syntax** probe-history [auto | drop | keep]

**Context** config>saa>test

**Description** Defines history probe behavior. Defaults are associated with various configured parameters within the SAA test. Auto (keep) is used for test with probe counts of 100 or less, and intervals of 1 second and above. Auto (drop) will only maintain summary information for tests marked as continuous with file functions, probe counts in excess of 100 and intervals of less than 1 second. SAA tests that are not continuous with a write to file will default to Auto (keep). The operator is free to change the default behaviors for each type. Each test that maintains per probe history will consume more system memory. When per probe entries are required the probe history is available at the completion of the test.

**Default** auto

**Parameters** *auto* — An auto selector that determines the storage of the history information.

*drop* — Store summarized min/max/ave data not per probe information for test runs. This may be configured for all tests in an effort to conserve memory.

*keep* — Store per probe information for tests. This consumes significantly more memory than summary information and should only be used if necessary.

## trap-gen

**Syntax** trap-gen

**Context** config>saa>test

**Description** This command enables the context to configure trap generation for the SAA test.

## probe-fail-enable

**Syntax** [no] probe-fail-enable

**Context** config>saa>test>trap-gen

**Description** This command enables the generation of an SNMP trap when probe-fail-threshold consecutive probes fail during the execution of the SAA ping test. This command is not applicable to SAA trace route tests.

The **no** form of the command disables the generation of an SNMP trap.

## probe-fail-threshold

**Syntax** [no] **probe-fail-threshold** *threshold*

**Context** config>saa>test>trap-gen

**Description** This command has no effect when probe-fail-enable is disabled. This command is not applicable to SAA trace route tests.

The **probe-fail-enable** command enables the generation of an SNMP trap when the probe-fail-threshold consecutive probes fail during the execution of the SAA ping test. This command is not applicable to SAA trace route tests.

The **no** form of the command returns the threshold value to the default.

**Default** 1

## test-completion-enable

**Syntax** [no] **test-completion-enable**

**Context** config>saa>test>trap-gen

**Description** This command enables the generation of a trap when an SAA test completes.

The **no** form of the command disables the trap generation.

## test-fail-enable

**Syntax** [no] **test-fail-enable**

**Context** config>saa>test>trap-gen

**Description** This command enables the generation of a trap when a test fails. In the case of a ping test, the test is considered failed (for the purpose of trap generation) if the number of failed probes is at least the value of the **test-fail-threshold** parameter.

The **no** form of the command disables the trap generation.

## test-fail-threshold

**Syntax** [no] **test-fail-threshold** *threshold*

**Context** config>saa>test>trap-gen

**Description** This command configures the threshold for trap generation on test failure.

This command has no effect when test-fail-enable is disabled. This command is not applicable to SAA trace route tests.

## OAM testhead commands

The **no** form of the command returns the threshold value to the default.

**Default** 1

### type

**Syntax** **type**  
**no type**

**Context** config>saa>test

**Description** This command creates the context to provide the test type for the named test. Only a single test type can be configured.

A test can only be modified while the test is in shut down mode.

Once a test type has been configured the command can be modified by re-entering the command, the test type must be the same as the previously entered test type.

To change the test type, the old command must be removed using the **config>saa>test>no type** command.

### dns

**Syntax** **dns target-addr dns-name name-server ip-address** [**source ip-address**] [**send-count send-count**] [**timeout timeout**] [**interval interval**] [**record-type {ipv4-a-record | ipv6-aaaa-record}**]

**Context** <GLOBAL>  
config>saa>test>type

**Description** This command configures a DNS name resolution test.

**Parameters** **target-addr** — Is a keyword to specify the domain name or IP address to be looked up.

*dns-name* — Specifies the domain name or IP address to be looked up.

**name-server ip-address** — Specifies the server connected to a network that resolves network names into network addresses.

**Values** ipv4-address - a.b.c.d  
ipv6-address - x:x:x:x:x:x:x (eight 16-bit pieces)  
x:x:x:x:x:x.d.d.d.d  
x - [0..FFFF]H  
d - [0..255]D

**source ip-address** — Specifies the IP address to be used as the source for performing an OAM ping operation.

**Values** ipv4-address - a.b.c.d  
ipv6-address - x:x:x:x:x:x:x (eight 16-bit pieces)  
x:x:x:x:x:x.d.d.d.d  
x - [0..FFFF]H  
d - [0..255]D

**send-count** *send-count* — The number of messages to send, expressed as a decimal integer. The **send-count** parameter is used to override the default number of message requests sent. Each message request must either timeout or receive a reply before the next message request is sent. The message **interval** value must be expired before the next message request is sent.

**Default** 1

**Values** 1 — 255

**timeout** *timeout* — The **timeout** parameter in seconds, expressed as a decimal integer. This value is used to override the default **timeout** value and is the amount of time that the router will wait for a message reply after sending the message request. Upon the expiration of message timeout, the requesting router assumes that the message response will not be received. Any response received after the request times out will be silently discarded.

**Default** 5

**Values** 1 — 120

**interval** *interval* — The **interval** parameter in seconds, expressed as a decimal integer. This parameter is used to override the default request message send interval and defines the minimum amount of time that must expire before the next message request is sent.

If the **interval** is set to 1 second, and the **timeout** value is set to 10 seconds, then the maximum time between message requests is 10 seconds and the minimum is 1 second. This depends upon the receipt of a message reply corresponding to the outstanding message request.

**Default** 1

**Values** 1 — 10

**record-type** — Specifies a record type.

**Values** **ipv4-a-record** - A record specific mapping a host name to an IPv4 address.

**ipv6-aaaa-record** - A record specific to the Internet class that stores a single IPv6 address.

## eth-cfm-linktrace

**Syntax** **eth-cfm-linktrace** *mac-address* **mep** *mep-id* **domain** *md-index* **association** *ma-index* [**ttl** *ttlvalue*] [**fc** {*fc-name*} ] [**send-count** *send-count*] [**timeout** *timeout*] [**interval** *interval*] [**record-type** {*ipv4-a-record*|*ipv6-aaaa-record*}]

**Context** config>saa>test>type

**Description** This command configures a CFM linktrace test in SAA.

**Parameters-** *mac-address* — Specifies a unicast destination MAC address.

**mep** *mep-id* — Specifies the target MAC address.

**Values** 1 — 8191

**domain** *md-index* — Specifies the MD index.

**Values** 1 — 4294967295

## OAM testhead commands

**association** *ma-index* — Specifies the MA index.

**Values** 1 — 4294967295

**tll** *tll-value* — Specifies the maximum number of hops traversed in the linktrace.

**Default** 64

**Values** 1— 255

**fc** *fc-name* — The **fc** parameter is used to indicate the forwarding class of the CFM Linktrace request messages.

The actual forwarding class encoding is controlled by the network egress mappings.

**Default** nc

**Values** be, l2, af, l1, h2, ef, h1, nc

**send-count** *send-count* — The number of messages to send, expressed as a decimal integer. The **count** parameter

is used to override the default number of message requests sent. Each message request must either timeout or receive a reply before the next message request is sent. The message **interval** value must be expired before the next message request is sent.

**Default** 1

**Values** 1 — 10

**timeout** *timeout* — The **timeout** parameter in seconds, expressed as a decimal integer. This value is used to override the default **timeout** value and is the amount of time that the router will wait for a message reply after sending the message request. Upon the expiration of message timeout, the requesting router assumes that the message response will not be received. Any response received after the request times out will be silently discarded. The **timeout** value must be less than the **interval**.

**Default** 5

**Values** 1 — 10

**interval** *interval* — The **interval** parameter in seconds, expressed as a decimal integer. This parameter is used to override the default request message send interval and defines the minimum amount of time that must expire before the next message request is sent.

If the **interval** is set to “1” second, and the **timeout** value is set to “10” seconds, then the maximum time between message requests is “10” seconds and the minimum is “1” second. This depends upon the receipt of a message reply corresponding to the outstanding message request. The **timeout** value must be less than the **interval**.

**Default** 5

**Values** 1 — 10

**record-type** — Specifies a record type.

**Values** ipv4-a-record — A record specific mapping a host name to an IPv4 address.  
ipv6-aaaa-record — A record specific to the Internet class that stores a single IPv6 address.

## eth-cfm-loopback

**Syntax** **eth-cfm-loopback** *mac-address* **mep** *mep-id* **domain** *md-index* **association** *ma-index* [**size** *datasize*] [**fc** {*fc-name*} ] [**count** *send-count*] [**timeout** *timeout*] [**interval** *interval*]

**Context** config>saa>test>type

**Description** This command configures an Ethernet CFM loopback test in SAA.

*mac-address* — Specifies a unicast destination MAC address.

**mep** *mep-id* — Specifies the target MAC address.

**Values** 1 — 8191

**domain** *md-index* — Specifies the MD index.

**Values** 1 — 4294967295

**association** *ma-index* — Specifies the MA index.

**Values** 1 — 4294967295

**size** *data-size* — The packet size in bytes, expressed as a decimal integer.

**Default** 0

**Values** 0 — 1500

**fc** *fc-name* — The **fc** parameter is used to indicate the forwarding class of the CFM Loopback request messages.

The actual forwarding class encoding is controlled by the network egress mappings.

**Default** nc

**Values** be, l2, af, l1, h2, ef, h1, nc

**count** *send-count* — The number of messages to send, expressed as a decimal integer. The **count** parameter is used to override the default number of message requests sent. Each message request must either timeout or receive a reply before the next message request is sent. The message **interval** value must be expired before the next message request is sent.

**Default** 1

**Values** 1 — 100

**timeout** *timeout* — The **timeout** parameter in seconds, expressed as a decimal integer. This value is used to override the default **timeout** value and is the amount of time that the router will wait for a message reply after sending the message request. Upon the expiration of message timeout, the requesting router assumes that the message response will not be received. Any response received after the request times out will be silently discarded. The **timeout** value must be less than the **interval**.

**Default** 5

**Values** 1 — 10

**interval** *interval* — The **interval** parameter in seconds, expressed as a decimal integer. This parameter is used to override the default request message send interval and defines the minimum amount of time that must expire before the next message request is sent.

## OAM testhead commands

If the **interval** is set to “1” second, and the **timeout** value is set to “10” seconds, then the maximum time between message requests is “10” seconds and the minimum is “1” second. This depends upon the receipt of a message reply corresponding to the outstanding message request. The **timeout** value must be less than the **interval**.

**Default** 5  
**Values** 1 — 10

## eth-cfm-two-way-delay

**Syntax** **eth-cfm-two-way-delay** *mac-address* **mep** *mep-id* **domain** *md-index* **association** *ma-index* [**fc** {*fc-name*} ] [**send-count** *send-count*] [**timeout** *timeout*] [**interval** *interval*]

**Context** config>saa>test>type

**Description-** This command configures an Ethernet CFM two-way delay test in SAA.

*mac-address* — Specifies a unicast destination MAC address.

**mep** *mep-id* — Specifies the target MAC address.

**Values** 1 — 8191

**domain** *md-index* — Specifies the MD index.

**Values** 1 — 4294967295

**association** *ma-index* — Specifies the MA index.

**Values** 1 — 4294967295

*tll ttl-value* — Specifies the maximum number of hops traversed in the linktrace.

**Default** 64

**Values** 1 — 255

**fc** *fc-name* — The **fc** parameter is used to indicate the forwarding class of the CFM two-delay request messages.

The actual forwarding class encoding is controlled by the network egress mappings.

**Default** nc

**Values** be, l2, af, l1, h2, ef, h1, nc

**send-count** *send-count* — The number of messages to send, expressed as a decimal integer. The **count** parameter

is used to override the default number of message requests sent. Each message request must either timeout or receive a reply before the next message request is sent. The message **interval** value must be expired before the next message request is sent.

**Default** 1

**Values** 1 — 100

**timeout** *timeout* — The **timeout** parameter in seconds, expressed as a decimal integer. This value is used to

override the default **timeout** value and is the amount of time that the router will wait for a message reply after sending the message request. Upon the expiration of message timeout, the requesting router assumes that the message response will not be received. Any response received after the request times out will be silently discarded. The **timeout** value must be less than the **interval**.

**Default** 5

**Values** 1 — 10

**interval** *interval* — The **interval** parameter in seconds, expressed as a decimal integer. This parameter is used to override the default request message send interval and defines the minimum amount of time that must expire before the next message request is sent.

If the **interval** is set to “1” second, and the **timeout** value is set to “10” seconds, then the maximum time between message requests is “10” seconds and the minimum is “1” second. This depends upon the receipt of a message reply corresponding to the outstanding message request. The **timeout** value must be less than the **interval**.

**Default** 5

**Values** [0.1, 0.2, .. 0.9] | [1, 2, .. 10]

## eth-cfm-two-way-slm

**Syntax** **eth-cfm-two-way-delay** *mac-address* **mep** *mep-id* **domain** *md-index* **association** *ma-index* [**fc** *fc-name*] [**send-count** *send-count*] [**size** *data-size*] [**timeout** *timeout*] [**interval** *interval*]

**Context** config>saa>test>type

**Description** This command configures an Ethernet CFM two-way SLM test in SAA.

*mac-address* — Specifies a unicast destination MAC address.

**mep** *mep-id* — Specifies the target MAC address.

**Values** 1 — 8191

**domain** *md-index* — Specifies the MD index.

**Values** 1 — 4294967295

**association** *ma-index* — Specifies the MA index.

**Values** 1 — 4294967295

**fc** *fc-name* — The *fc* parameter is used to indicate the forwarding class of the CFM SLM request messages. The actual forwarding class encoding is controlled by the network egress mappings.

**Default** nc

**Values** be, l2, af, l1, h2, ef, h1, nc

**send-count** *send-count* — The number of messages to send, expressed as a decimal integer. The count parameter is used to override the default number of message requests sent. Each message request must either timeout or receive a reply before the next message request is sent. The message interval value must be expired before the next message request is sent.

## OAM testhead commands

**Default** 1

**Values** 1 — 100

**size** *data-size* — This is the size of the data portion of the data TLV. If 0 is specified no data TLV is added to the packet.

**Default** 0

**Values** 0 — 1500

**timeout** *timeout* — The timeout parameter in seconds, expressed as a decimal integer. This value is used to override the default timeout value and is the amount of time that the router waits for a message reply after sending the message request. Upon the expiration of message timeout, the requesting router assumes that the message response is not received. Any response received after the request times out is silently discarded. The timeout value must be less than the interval.

**Default** 5

**Values** 1 — 10

**interval** *interval* — The interval parameter in seconds, expressed as a decimal integer. This parameter is used to override the default request message send interval and defines the minimum amount of time that must expire before the next message request is sent. If the interval is set to 1 second, and the timeout value is set to 10 seconds, then the maximum time between message requests is 10 seconds and the minimum is 1 second. This depends upon the receipt of a message reply corresponding to the outstanding message request. The timeout value must be less than the interval.

**Default** 5

**Values** [0.1, 0.2, .. 0.9] | [1, 2, .. 10]

## icmp-ping

**Syntax** **icmp-ping** [*ip-address* | *dns-name*] [**rapid** | **detail**] [**ttl** *time-to-live*] [**tos** *type-of-service*] [**size** *bytes*] [**pattern** *pattern*] [**source** *ip-address*] [**interval** *seconds*] [{**next-hop** *ip-address*} | {**interface** *interface-name*}] [**bypass-routing**] [**count** *requests*] [**do-not-fragment**] [**router** *router-instance* | **service-name** *service-name*] [**timeout** *timeout*]

**Context** config>saa>test>type

**Description** This command configures an ICMP ping test.

**Parameters** *ip-address* — The far-end IP address to which to send the **icmp-ping** request message in dotted decimal notation.

**Values**

ipv4-address:	a.b.c.d
ipv6-address:	x:x:x:x:x:x:x (eight 16-bit pieces)
	x:x:x:x:x:d.d.d.d
x:	[0 .. FFFF]H
d:	[0 .. 255]D

*dns-name* — The DNS name of the far-end device to which to send the **icmp-ping** request message, expressed as a character string up to 63 characters maximum.

**rapid** — Packets will be generated as fast as possible instead of the default 1 per second.

**detail** — Displays detailed information.

**ttl** *time-to-live* — The TTL value for the IP packet, expressed as a decimal integer.

**Values** 1 — 128

**tos** *type-of-service* — Specifies the service type.

**Values** 0 — 255

**size** *bytes* — The request packet size in bytes, expressed as a decimal integer.

**Values** 0 — 16384

**pattern** *pattern* — The date portion in a ping packet will be filled with the pattern value specified. If not specified, position info will be filled instead.

**Values** 0 — 65535

**source** *ip-address* — Specifies the IP address to be used.

**Values** ipv4-address: a.b.c.d

**interval** *seconds* — This parameter is used to override the default request message send interval and defines the minimum amount of time that must expire before the next message request is sent.

If the **interval** is set to 1 second, and the **timeout** value is set to 10 seconds, then the maximum time between message requests is 10 seconds and the minimum is 1 second. This depends upon the receipt of a message reply corresponding to the outstanding message request.

**Default** 1

**Values** 1 — 10

**next-hop** *ip-address* — Only displays static routes with the specified next hop IP address.

**Values** ipv4-address: a.b.c.d (host bits must be 0)

**interface** *interface-name* — The name used to refer to the interface. The name must already exist in the **config>router>interface** context.

**bypass-routing** — Specifies whether to send the ping request to a host on a directly attached network bypassing the routing table.

**count** *requests* — Specifies the number of times to perform an OAM ping probe operation. Each OAM echo message request must either timeout or receive a reply before the next message request is sent.

**Values** 1 — 100000

**Default** 5

**do-not-fragment** — Sets the DF (Do Not Fragment) bit in the ICMP ping packet.

**router** *router-instance* — Specifies the router name or service ID.

**Values** *router-name:* Base , management  
*service-id:* 1 — 2147483647

**Default** Base

**service-name** *service-name* — Specifies the service name as an integer.

## OAM testhead commands

**Values** *service-id:* 1 — 2147483647

**timeout** *timeout* — Overrides the default **timeout** value and is the amount of time that the router will wait for a message reply after sending the message request. Upon the expiration of message timeout, the requesting router assumes that the message response will not be received. Any response received after the request times out will be silently discarded.

**Default** 5

**Values** 1 — 10

## icmp-trace

**Syntax** **icmp-trace** [*ip-address* | *dns-name*] [**ttl** *time-to-live*] [**wait** *milli-seconds*] [**tos** *type-of-service*] [**source** *ip-address*] [**tos** *type-of-service*] [**router** *router-instance* | **service-name** *service-name*]

**Context** config>saa>test>type

**Description** This command configures an ICMP traceroute test.

**Parameters** *ip-address* — The far-end IP address to which to send the **icmp-ping** request message in dotted decimal notation.

**Values**

ipv4-address:	a.b.c.d
ipv6-address:	x:x:x:x:x:x:x (eight 16-bit pieces)
	x:x:x:x:x:d.d.d.d
x:	[0 .. FFFF]H
d:	[0 .. 255]D

*dns-name* — The DNS name of the far-end device to which to send the **icmp-ping** request message, expressed as a character string to 63 characters maximum.

**ttl** *time-to-live* — The TTL value for the IP TTL, expressed as a decimal integer.

**Values** 1 — 255

**wait** *milliseconds* — The time in milliseconds to wait for a response to a probe, expressed as a decimal integer.

**Default** 5000

**Values** 10 — 60000

**tos** *type-of-service* — Specifies the service type.

**Values** 0 — 255

**source** *ip-address* — Specifies the IP address to be used.

**Values**

ipv4-address:	a.b.c.d
ipv6-address:	x:x:x:x:x:x:x (eight 16-bit pieces)
	x:x:x:x:x:d.d.d.d
x:	[0 .. FFFF]H
d:	[0 .. 255]D



## OAM testhead commands

attachment individual identifier (SAII) must be indicated.

The **saii-type2** parameter is mutually exclusive with the *sdp-id:vc-id* parameter.

**Syntax:** *global-id* — The global ID of this T-PE node.

Values: 1 — 4294967295

*prefix* — The prefix on this T-PE node that the spoke-SDP is associated with.

*ac-id* — An unsigned integer representing a locally unique identifier for the spoke-SDP.

Values: 1 — 4294967295

**taii-type2** *global-id:prefix:ac-id* — If a FEC129 AII Type 2 pseudowire is being tested, then the target attachment individual identifier (TAII) must be indicated. The **taii-type2** parameter is mutually exclusive with *sdp-id:vc-id*.

**Syntax:** *global-id* — The global ID of the far end T-PE node of the FEC129 pseudowire.

Values: 1 — 4294967295

*prefix* — The prefix on far end T-PE node that the pseudowire being tested is associated with.

Values: ipv4-formatted address: a.b.c.d

*ac-id* — An unsigned integer representing a locally unique identifier for the pseudowire being tested at the far end T-PE.

Values: 1 — 4294967295

---

## OAM SAA Commands

### saa

**Syntax** `saa test-name [owner test-owner] {start | stop} [no-accounting]`

**Context** oam

**Description** Use this command to start or stop an SAA test.

*test-name* — Name of the SAA test. The test name must already be configured in the **config>saa>test** context.

**owner test-owner** — Specifies the owner of an SAA operation up to 32 characters in length.

**Values** If a *test-owner* value is not specified, tests created by the CLI have a default owner “TiMOS CLI”.

**start** — This keyword starts the test. A test cannot be started if the same test is still running.

A test cannot be started if it is in a shut-down state. An error message and log event will be generated to indicate a failed attempt to start an SAA test run. A test cannot be started if it is in a continuous state.

**stop** — This keyword stops a test in progress. A test cannot be stopped if it is not in progress. A log message will be generated to indicate that an SAA test run has been aborted. A test cannot be stopped if it is in a continuous state.

**no-accounting** — This parameter disables the recording results in the accounting policy. If **no-accounting** is specified, the MIB record produced at the end of the test will not be added to the accounting file. It will however use up one of the three MIB rows available for the accounting module to be collected.

---

## Twamp commands

### twamp

<b>Syntax</b>	<b>twamp</b>
<b>Context</b>	config>oam-test
<b>Description</b>	This command enables TWAMP functionality.
<b>Default</b>	TWAMP is disabled.

### server

<b>Syntax</b>	<b>retry-count</b> <i>retry-count</i>
<b>Context</b>	config>test-oam>twamp
<b>Description</b>	This command configures the node for TWAMP server functionality.
<b>Default</b>	TWAMP is disabled.

### prefix

<b>Syntax</b>	<b>prefix</b> { <i>ip-prefix</i>   <i>mask</i> } <b>no prefix</b>
<b>Context</b>	config>test-oam>twamp>server
<b>Description</b>	This command configures an IP address prefix containing one or more TWAMP clients. In order for a TWAMP client to connect to the TWAMP server (and subsequently conduct tests) it must establish the control connection using an IP address that is part of a configured prefix.
<b>Default</b>	no prefix
<b>Parameters</b>	<b>prefix</b> <i>ip-prefix/mask</i> — Specifies the address prefix and subnet mask of the destination node. <i>ip-prefix</i> — An IPv4 address in dotted decimal notation. <b>Values</b> a.b.c.d <b>Default</b> none <i>mask</i> — The prefix length. <b>Values</b> 0—32 <b>Default</b> none

## max-conn-prefix

<b>Syntax</b>	<b>max-conn-prefix</b> <i>count</i> <b>no max-conn-prefix</b>
<b>Context</b>	config>test-oam>twamp>server>prefix
<b>Description</b>	This command configures the maximum number of TWAMP control connections by clients with an IP address in a specific prefix. A new control connection is rejected if accepting it would cause either the prefix limit defined by this command or the server limit (max-conn-server) to be exceeded.  The no form of the command sets the default value.
<b>Default</b>	no max-conn-prefix
<b>Parameters</b>	<i>count</i> — The maximum number of control connections.
	<b>Values</b> 0—48
	<b>Default</b> 24

## max-conn-server

<b>Syntax</b>	<b>max-conn-server</b> <i>count</i> <b>no max-conn-server</b>
<b>Context</b>	config>test-oam>twamp>server
<b>Description</b>	This command configures the maximum number of TWAMP control connections from all TWAMP clients. A new control connection is rejected if accepting it would cause either this limit or a prefix limit (max-conn-prefix) to be exceeded.  The no form of the command sets the default value.
<b>Default</b>	no max-conn-server
<b>Parameters</b>	<i>count</i> — The maximum number of control connections.
	<b>Values</b> 0—8
	<b>Default</b> 4

## inactivity-timeout

<b>Syntax</b>	<b>inactivity-timeout</b> <i>seconds</i> <b>no inactivity-timeout</b>
<b>Context</b>	config>test-oam>twamp>server
<b>Description</b>	This command configures the inactivity timeout for all TWAMP-control connections. If no TWAMP control message is exchanged over the TCP connection for this duration of time the connection is closed and all inprogress tests are terminated.

## OAM testhead commands

The no form of the command instructs the system to go with the default value.

**Default** no inactivity-timeout

**Parameters** *retry-count* — The duration of the inactivity timeout.

**Values** 60— 3600

**Default** 900

## max-sess-prefix

**Syntax** **max-sess-prefix** *count*  
**no max-sess-prefix**

**Context** config>test-oam>twamp>server>prefix

**Description** This command configures the maximum number of concurrent TWAMP-Test sessions by clients with an IP address in a specific prefix. A new test session (described by a Request-TW-Session message) is rejected if accepting it would cause either the limit defined by this command or the server limit (max-sess-server) to be exceeded.

The no form of the command instructs the system to go with the default value.

**Default** no max-sess-prefix

**Parameters** *count* — The maximum number of concurrent test sessions.

**Values** 0—48

**Default** 24

## max-sess-server

**Syntax** **max-sess-server** *count*  
**no max-sess-server**

**Context** config>test-oam>twamp>server

**Description** This command configures the maximum number of concurrent TWAMP-Test sessions across all allowed clients.

A new test session (described by a Request-TW-Session message) is rejected if accepting it would cause either the limit defined by this command or a prefix limit (max-sess-prefix) to be exceeded.

The no form of the command instructs the system to go with the default value.

**Default** no max-sessions

**Parameters** *count* — The maximum number of concurrent test sessions.

**Values** 0— 8

**Default** 4

## port

**Syntax**    **port** *number*  
              **no port**

**Context**    config>test-oam>twamp>server

**Description**    This command configures the TCP port number used by the TWAMP server to listen for incoming connection requests from TWAMP clients.

The port number can be changed only when the server has been shutdown.

The no form of this command means to go with the default of 862.

**Default**    no port

**Parameters**    *number* — The TCP port number.

**Values**    1 — 65535

**Default**    862

---

## Show Commands

### saa

**Syntax** `saa [test-name] [owner test-owner]`

**Context** `show>saa`

**Description** Use this command to display information about the SAA test.

If no specific test is specified a summary of all configured tests is displayed.

If a specific test is specified then detailed test results for that test are displayed for the last three occurrences that this test has been executed, or since the last time the counters have been reset via a system reboot or clear command.

**Parameters** *test-name* — Enter the name of the SAA test for which the information needs to be displayed. The test name must already be configured in the `config>saa>test` context.

This is an optional parameter.

**owner test-owner** — Specifies the owner of an SAA operation up to 32 characters in length.

**Values** 32 characters maximum.

**Default** If a *test-owner* value is not specified, tests created by the CLI have a default owner "TIMOS CLI".

**Output** **SAA Output** — The following table provides SAA field descriptions.

Label	Description
Test Name	Specifies the name of the test.
Owner Name	Specifies the owner of the test.
Description	Specifies the description for the test type.
Accounting policy	Specifies the associated accounting policy ID.
Administrative status	Specifies whether the administrative status is enabled or disabled.
Test type	Specifies the type of test configured.
Trap generation	Specifies the trap generation for the SAA test.
Test runs since last clear	Specifies the total number of tests performed since the last time the tests were cleared.
Number of failed tests run	Specifies the total number of tests that failed.

Label	Description (Continued)
Last test run	Specifies the last time a test was run.
Threshold type	Indicates the type of threshold event being tested, jitter-event, latency-event, or loss-event, and the direction of the test responses received for a test run: in — inbound out — outbound rt — roundtrip
Direction	Indicates the direction of the event threshold, rising or falling.
Threshold	Displays the configured threshold value.
Value	Displays the measured crossing value that triggered the threshold crossing event.
Last event	Indicates the time that the threshold crossing event occurred.
Run #	Indicates what test run produced the specified values.

\*A:7210 SAS>show# saa

```

=====
SAA Test Information
=====
Test name           : abc
Owner name          : TiMOS CLI
Description          : test
Accounting policy   : None
Administrative status : Disabled
Test type            : Not configured
Trap generation     : None
Test runs since last clear : 0
Number of failed test runs : 0
Last test result    : Undetermined
-----
Threshold
Type      Direction Threshold Value      Last Event      Run #
-----
Jitter-in Rising      None      None      Never           None
          Falling    None      None      Never           None
Jitter-out Rising      None      None      Never           None
          Falling    None      None      Never           None
Jitter-rt Rising      100      None      Never           None
          Falling    10.0     None      Never           None
Latency-in Rising      None      None      Never           None
          Falling    None      None      Never           None
Latency-out Rising      None      None      Never           None
          Falling    None      None      Never           None
Latency-rt Rising      100      None      Never           None
          Falling    20.0     None      Never           None
Loss-in   Rising      None      None      Never           None
          Falling    None      None      Never           None
Loss-out  Rising      None      None      Never           None
          Falling    None      None      Never           None

```

## OAM testhead commands

```
Loss-rt      Rising      300      None      Never      None
             Falling      30       None      Never      None
```

```
=====
```

```
=====
```

```
*A: 7210 SAS>show#
```

## test-oam

**Syntax** test-oam

**Context** show

**Description** This command enables the context to display Operations, Administration, and Maintenance test parameters

## eth-cfm

**Syntax** eth-cfm

**Context** show

**Description** This command enables the context to display CFM information.

## association

**Syntax** association [*ma-index*] [*detail*]

**Context** show>eth-cfm

**Description** This command displays eth-cfm association information.

**Parameters** *ma-index* — Specifies the MA index.

**Values** 1— 4294967295

**detail** — Displays detailed information for the eth-cfm association.

### Sample Output

```
ALU-IPD# show eth-cfm association
```

```
=====
CFM Association Table
=====
```

Md-index	Ma-index	Name	CCM-intrvl	Hold-time	Bridge-id
3	1	03-0000000100	1	n/a	100
10	1	FacilityPrt01	1	n/a	none

```
=====
ALU-IPD#
```

## cfm-stack-table

**Syntax** `cfm-stack-table [port port-id [vlan vlan-id]][level 0..7] [direction up | down]`

**Context** show>eth-cfm

**Description** This command displays stack-table information. This stack-table is used to display the various management points MEPs and MIPs that are configured on the system. These can be Service based or facility based. The various option allow the operator to be specific. If no parameters are include then the entire stack-table will be displayed.

**Parameters** **port** *port-id* — Displays the bridge port or aggregated port on which MEPs or MHFs are configured.

**vlan** *vlan-id* — Displays the associated VLAN ID.

**Values** 0 — 4094

**level** — Display the MD level of the maintenance point.

**Values** 0 — 7

**direction up | down** — Displays the direction in which the MP faces on the bridge port.

### Sample Output

```
*ALU-IPD# show eth-cfm cfm-stack-table
=====
CFM SAP Stack Table
=====
Sap           Level Dir  Md-index  Ma-index  Mep-id  Mac-address
-----
lag-1:1.1     0     Down  2         1         10     00:f3:f0:98:97:1b
lag-1:1.1     6     Down  1         1         1      00:f3:f0:98:97:1b
lag-1:2.2     0     Down  2         2         20     00:f3:f0:98:97:1b
lag-1:2.2     6     Down  1         2         2      00:f3:f0:98:97:1b
=====
*ALU-IPD#
```

## domain

**Syntax** `domain [md-index] [association ma-index | all-associations] [detail]`

**Context** show>eth-cfm

**Description** This command displays domain information.

**Parameters** ***md-index*** — Displays the index of the MD to which the MP is associated, or 0, if none.

**Values** [1..4294967295]

## OAM testhead commands

**association *ma-index*** — Displays the index to which the MP is associated, or 0, if none.

**all-associations** — Displays all associations to the MD.

**detail** — Displays detailed domain information.

### Sample Output

```
*ALU-IPD# show eth-cfm domain
=====
CFM Domain Table
=====
Md-index   Level Name                                     Format
-----
1           6                                               none
2           0                                               none
=====
*ALU-IPD#
```

## mep

**Syntax** **mep** *mep-id* **domain** *md-index* **association** *ma-index* [**loopback**] [**linktrace**]  
**mep** *mep-id* **domain** *md-index* **association** *ma-index* [**remote-mepid** *mep-id* | **all-remote-mepids**]  
**mep** *mep-id* **domain** *md-index* **association** *ma-index* **eth-test-results** [**remote-peer** *mac-address*]  
**mep** *mep-id* **domain** *md-index* **association** *ma-index* **one-way-delay-test** [**remote-peer** *mac-address*]  
**mep** *mep-id* **domain** *md-index* **association** *ma-index* **two-way-delay-test** [**remote-peer** *mac-address*]  
**mep** *mep-id* **domain** *md-index* **association** *ma-index* **two-way-slm-test** [**remote-peer** *mac-address*]

**Context** show>eth-cfm

**Description** This command displays Maintenance Endpoint (MEP) information.

**Parameters** **domain** *md-index* — Displays the index of the MD to which the MP is associated, or 0, if none.  
**association** *ma-index* — Displays the index to which the MP is associated, or 0, if none.  
**loopback** — Displays loopback information for the specified MEP.  
**linktrace** — Displays linktrace information for the specified MEP.  
**remote-mepid** — Includes specified remote MEP ID information for the specified MEP.  
**one-way-delay-test** — Includes specified MEP information for one-way-delay-test.  
**two-way-delay-test** — Includes specified MEP information for two-way-delay-test.  
**two-way-slm-test** — Includes specified MEP information for two-way-slm-test.  
**eth-test-results** — Include eth-test-result information for the specified MEP.  
**all-remote-mepids** — Includes all remote mep-id information for the specified MEP.

## mip

**Syntax** mip**Context** show>eth-cfm**Description** This command displays SAPs/bindings provisioned for allowing the default MIP creation.

```
*A:node-1# show eth-cfm mip
=====
CFM SAP MIP Table
=====
Sap Mip-Enabled Mip Mac Address
-----
1/1/1:1.1 yes Not Configured
=====
CFM SDP MIP Table
=====
Sdp Mip-Enabled Mip Mac Address
-----
No Matching Entries
```

## system-config

**Syntax** system-config**Context** show>eth-cfm**Description** This command shows various system level configuration parameters. These global eth-cfm commands are those which are configured directly under the config>eth-cfm context.

```
# show eth-cfm system-config
=====
CFM System Configuration
=====
Redundancy
MC-LAG Standby MEP Shutdown: true
MC-LAG Hold-Timer : 1 second(s)
Synthetic Loss Measurement
Inactivity Timer : 100 second(s)
=====
```

## twamp server

**Syntax** twamp server**Context** show>test-oam**Description** Used to obtain information about the TWAMP server. It displays summary information for the ip-prefix in use.

## OAM testhead commands

### Sample Output

```
*A:Dut-G>show>test-oam# twamp server

=====
TWAMP Server
=====
Admin State           : Down                Operational State    : Down
Up Time               : 0d 00:00:00
Current Connections   : 0                    Max Connections     : 8
Connections Rejected : 0                    Inactivity Time Out : 900 seconds
Current Sessions      : 0                    Max Sessions        : 8
Sessions Rejected     : 0                    Sessions Aborted    : 0
Sessions Completed    : 0
Test Packets Rx       : 0                    Test Packets Tx     : 0
=====

TWAMP Server Prefix Summary
=====
Prefix                Current    Current    Description
                   Connections Sessions
-----
No. of TWAMP Server Prefixes: 0
=====
*A:Dut-G>show>test-oam#
```

## server all

**Syntax** server all

**Context** show>test-oam twamp server

**Description** Used to display detailed information about the TWAMP server and TWAMP clients using different IP prefix.

### Sample Output

```
7210SASM# show test-oam twamp server all

=====
TWAMP Server
=====
Admin State           : Up                Operational State    : Up
Up Time               : 0d 08:17:34
Current Connections   : 0                    Max Connections     : 16
Connections Rejected : 0                    Inactivity Time Out : 900 seconds
Current Sessions      : 0                    Max Sessions        : 16
Sessions Rejected     : 0                    Sessions Aborted    : 0
Sessions Completed    : 0
Test Packets Rx       : 0                    Test Packets Tx     : 0
=====

=====
```

```

TWAMP Server Prefix 30.1.1.0/24
=====
Description          : (Not Specified)
Current Connections  : 0                Max Connections     : 16
Connections Rejected : 0
Current Sessions     : 0                Max Sessions        : 16
Sessions Rejected    : 0                Sessions Aborted     : 0
Sessions Completed   : 0
Test Packets Rx      : 0                Test Packets Tx      : 0
=====

=====
Connection information for TWAMP server prefix 30.1.1.0/24
=====
Client              State      Curr Sessions  Sessions Rejected  Sessions Completed
                  Idle Time (s)  Test Packets Rx  Test Packets Tx
-----
No. of TWAMP Server Connections for Prefix 30.1.1.0/24: 0
=====

TWAMP Server Prefix 60.1.1.0/24
=====
Description          : (Not Specified)
Current Connections  : 0                Max Connections     : 16
Connections Rejected : 0
Current Sessions     : 0                Max Sessions        : 16
Sessions Rejected    : 0                Sessions Aborted     : 0
Sessions Completed   : 0
Test Packets Rx      : 0                Test Packets Tx      : 0
=====

=====
Connection information for TWAMP server prefix 60.1.1.0/24
=====
Client              State      Curr Sessions  Sessions Rejected  Sessions Completed
                  Idle Time (s)  Test Packets Rx  Test Packets Tx
-----
No. of TWAMP Server Connections for Prefix 60.1.1.0/24: 0
=====

No. of TWAMP Server Prefixes: 2
=====

```

## server prefix

**Syntax** server prefix *ip-prefix/mask*

**Context** show>test-oam twamp server

**Description** Display information about the TWAMP clients using the specified prefix.

## OAM testhead commands

### Sample output

```
*A:7210SAS# show test-oam twamp server prefix 60.1.1.0/24

=====
TWAMP Server Prefix 60.1.1.0/24
=====
Description          : (Not Specified)
Current Connections  : 0                Max Connections      : 16
Connections Rejected : 0
Current Sessions    : 0                Max Sessions         : 16
Sessions Rejected   : 0                Sessions Aborted     : 0
Sessions Completed   : 0
Test Packets Rx     : 0                Test Packets Tx      : 0
=====

=====
Connection information for TWAMP server prefix 60.1.1.0/24
=====
Client              State      Curr Sessions  Sessions Rejected  Sessions Completed
                  Idle Time (s)  Test Packets Rx  Test Packets Tx
-----
No. of TWAMP Server Connections for Prefix 60.1.1.0/24: 0
=====
```

**Parameters** *ip-prefix* — The destination address of the static route.

**Values** [18 chars max]

*mask* — The prefix length.

## testhead-profile

**Syntax** `testhead-profile profile-id`

**Context** `show>test-oam`

**Description** Specifies the testhead profile ID to use with this run/session of testhead invocation. Testhead profile must be configured beforehand using the commands under `config> test-oam> testhead-profile>`.

**Output** **Testhead-profile Output** — The following table provides testhead-profile field descriptions.

Label	Description
Description	Displays the description configured by the user for the test.
Profile Id	Displays the profile identifier.
CIR Configured	Displays the value of the CIR configured.
PIR Configured	Displays the value of the PIR configured.
Frame Size	Displays the size of the frame.

Label	Description (Continued)
CIR Operational	Displays the value of the CIR operational rate configured.
PIR Operational	Displays the value of the PIR operational rate configured.
CIR Rule	Displays the adaptation rule configured by the user.
InPrf Dot1p	Displays the dot1p value used to identify green or in-profile packets.
Ref. Count	Displays the total number of testhead (completed or running) sessions pointing to a profile or acceptance criteria or a frame payload.
OutPrf Dot1p	Displays the dot1p value used to identify green or out-of-profile packets.
Duration Hrs, mins, and secs	Displays the test duration in hours, minutes, and seconds.
Loss TH	Displays the user configured loss threshold value for comparison with measured value.
Jitter TH	Displays the user configured jitter threshold value for comparison with measured value.
InProf Loss TH	Displays the user configured in-profile loss threshold value for comparison with measured value.
OutProf Loss TH	Displays the user configured out-of-profile loss threshold value for comparison with measured value.
Latency TH	Displays the user configured latency threshold value for comparison with measured value.
InProf Latency TH	Displays the user configured in-profile latency threshold value for comparison with measured value.
OutProf Latency TH	Displays the user configured out-of-profile latency threshold value for comparison with measured value.
InProf Jitter TH	Displays the user configured in-profile jitter threshold value for comparison with measured value.
OutProf Jitter TH	Displays the user configured out-of-profile jitter threshold value for comparison with measured value.
CIR TH	Displays the user configured CIR threshold value for comparison with measured value.
PIR TH	Displays the user configured PIR threshold value for comparison with measured value.
Payload Type	Identifies the type of the payload.

## OAM testhead commands

<b>Label</b>	<b>Description (Continued)</b>
Dst Mac	Displays the value of destination MAC configured by the user to use in the frame generated by the testhead tool
Src Mac	Displays the value of source MAC configured by the user to use in the frame generated by the testhead tool
Vlan Tag 1	Displays the values of the outermost vlan-tag configured by the user to use in the frame generated by the testhead tool.
Vlan Tag 2	Displays the values of the second vlan-tag configured by the user to use in the frame generated by the testhead tool.
Ethertype	Displays the values of the ethertype configured by the user to use in the frame generated by the testhead tool.
TOS	Displays the values of the IP TOS (Type of Service) configured by the user to use in the frame generated by the testhead tool.
Src. IP	Displays the values of the source IPv4 address configured by the user to use in the frame generated by the testhead tool.
L4 Dst Port	Displays the values of the TCP header configured by the user to use in the frame generated by the testhead tool.
Protocol	Displays the values of the IP protocol value configured by the user to use in the frame generated by the testhead tool.
Data Pattern	Displays the values of the data pattern configured by the user to use in the frame generated by the testhead tool.
DSCP	Displays the values of the DSCP configured by the user to use in the frame generated by the testhead tool.
TTL	Displays the values of the IP TTL (Time-to-Live) value configured by the user to use in the frame generated by the testhead tool.
Dst. IP	Displays the values of the destination IPv4 address configured by the user to use in the frame generated by the testhead tool.
L4 Src Port	Displays the values of the source port configured by the user to use in the frame generated by the testhead tool.

### Sample Output

```
*A:7210SAS>config>test-oam># show test-oam testhead-profile 1
=====
Y.1564 Testhead Profile
=====
Description          : Testhead_Profile_1
```

```

Profile Id           : 1                Frame Size          : 512
CIR Configured      : 100              CIR Operational     : 96
PIR Configured      : 200              PIR Operational     : 200
CIR Rule            : max               Ref. Count          : 0
InPrf Dot1p        : 2                 OutPrf Dot1p       : 4
Duration Hrs        : 0
Duration Mins       : 3
Duration Secs       : 0
    
```

-----  
Acceptance Criteria Id 1  
-----

```

Loss TH              : 0.000100        Jitter TH           : 100
InProf Loss TH      : 0.000100        InProf Jitter TH    : 100
OutProf Loss TH     : 0.000100        OutProf Jitter TH   : 100

Latency TH          : 100              Ref. Count          : 0
InProf Latency TH  : 100              CIR TH              : 1000
OutProf Latency TH : 100              PIR TH              : 200
    
```

-----  
Frame Payload Id 1  
-----

```

Payload Type        : tcp-ipv4
Description         : Frame_Payload_1
Dst Mac            : 00:00:00:00:00:02
Src Mac            : 00:00:00:00:00:01
Vlan Tag 1         : Not configured
Vlan Tag 2         : Not configured
Ethertype          : 0x0800            DSCP                 : af11
TOS                : 8                 TTL                  : 64
Src. IP            : 1.1.1.1           Dst. IP              : 2.2.2.2
L4 Dst Port        : 50                L4 Src Port          : 40
Protocol           : 6                 Ref. Count           : 0
Data Pattern       : alb2c3d4e5f6
    
```

=====

```

*A:7210SAS>config>test-oam>#
    
```

## testhead

**Syntax** `testhead test-name owner test-owner`

**Context** show

**Parameters** *test-name* — Name of the SAA test. The test name must already be configured in the `config>saa>test` context.

**owner test-owner** — Specifies the owner of an SAA operation up to 32 characters in length.

**Default** If a *test-owner* value is not specified, tests created by the CLI have a default owner “TiMOS CLP”.

**Output** **Testhead Output** — The following table provides “testhead test-me owner owner-me” field descriptions.

## OAM testhead commands

<b>Label</b>	<b>Description</b>
Owner	Displays the owner of the test.
Name	Displays the name of the test.
Description	Displays the description for the test type.
Profile Id	Displays the associated profile ID.
Accept. Crit. Id	Displays the test acceptance criteria ID to be used by the testhead OAM tool to declare the PASS/FAIL result at the completion of the test.
Frame Payload Id	Displays frame payload ID, that determines the frame content of the frames generated by the tool.
Frame Payload Type	Displays the type of frame payload to be used in frames generated by testhead tool.
Color Aware Test	Displays if color aware tests need to be executed.
SAP	Displays the SAP ID configured.
Completed	Displays if the test has been completed.
Stopped	Displays if the test has been stopped.
FC	Displays the forwarding class (FC) to use to send the frames generated by the testhead tool.
Start Time	Displays the start time of the test.
End Time	Displays the end time of the test.
Total time taken	Displays the total time taken to execute the test.
total pkts in us	Displays the total packets in microseconds.
OutPrf pkts in us	Displays the out-of-profile packets in microseconds.
InPrf pkts in us	Displays the in-profile packets in microseconds.
Total Injected	Displays the running count of total injected packets, including marker packets.
Total Received	Displays the running count of total received packets, including marker packets.
OutPrf Injected	Displays the running count of total out-of-profile packets, excluding marker packets.
OutPrf Received	Displays the running count of total out-of-profile packets received, including marker packets.

Label	Description (Continued)
InPrf Injected	Displays the running count of total in-profile packets, excluding marker packets.
InPrf Received	Displays the running count of total in-profile packets received, including marker packets.
Throughput Con- figd	Displays the CIR Throughput rate Threshold Configured (in Kbps).
Throughput Oper	Displays the operational rate used for the configured rate. Operational rate is arrived considering the adaptation rule configured by the user and supported hardware rate.
Throughput Mea- surd	Displays the CIR Throughput Measured Value (in Kbps).
PIR Tput Threshld	Displays the PIR Throughput rate Threshold Configured (in Kbps).
PIR Tput Meas	Displays the PIR Throughput rate Measured Value (in Kbps).
FLR Configured	Displays the Frame Loss Ratio Threshold Configured (in-profile).
FLR Measurd	Displays the Frame Loss Ratio Measured (in-profile).
FLR Acceptance	Displays Pass, Fail, or Not Applicable. It displays Pass, if the measured value is less than or equal to the configured threshold and displays "Fail" otherwise, and displays "Not Applicable", if the FLR criteria is not used to determine whether the test is in Passed or Failed status.
OutPrf FLR Conf	Displays the out-of-profile Frame Loss Ratio configured.
OutPrf FLR Meas	Displays the out-of-profile Frame Loss Ratio measured.
OutPrf FLR Acep	Displays Pass, Fail, or Not Applicable. It displays Pass, if the measured value is less than or equal to the configured threshold and displays "Fail" otherwise, and displays "Not Applicable", if the out-of-profile FLR criteria is not used to determine whether the test is in Passed or Failed status.
InPrf FLR Conf	Displays the in-profile Frame Loss Ratio configured.
InPrf FLR Meas	Displays the in-profile Frame Loss Ratio measured.
InPrf FLR Acep	Displays Pass, Fail, or Not Applicable. It displays Pass, if the measured value is less than or equal to the configured threshold and displays "Fail" otherwise, and displays "Not Applicable", if the in-profile FLR criteria is not used to determine whether the test is in Passed or Failed status.

## OAM testhead commands

Label	Description (Continued)
Latency Con- figd(us)	Displays the Latency Threshold configured (in microseconds)
Latency Mea- surd(us)	Displays the Average Latency measured (in microseconds)
Latency Accep- tance	Displays Pass, Fail, or Not Applicable. It displays Pass, if the measured value is less than or equal to the configured threshold and displays "Fail" otherwise, and displays "Not Applicable", if the latency criteria is not used to determine whether the test is in Passed or Failed status.
OutPrf Lat Conf(us)	Displays the out-of-profile latency configured.
OutPrf Lat Meas(us)	Displays the out-of-profile latency measured.
OutPrf Lat Acep	Displays Pass, Fail, or Not Applicable. It displays Pass, if the measured value is less than or equal to the configured threshold and displays "Fail" otherwise, and displays "Not Applicable", if the out-of-profile latency criteria is not used to determine whether the test is in Passed or Failed status.
InPrf Lat Conf(us)	Displays the in-profile latency configured.
InPrf Lat Meas(us)	Displays the in-profile latency measured.
InPrf Lat Acep	Displays Pass, Fail, or Not Applicable. It displays Pass, if the measured value is less than or equal to the configured threshold and displays "Fail" otherwise, and displays "Not Applicable", if the in-profile latency criteria is not used to determine whether the test is in Passed or Failed status.
Jitter Con- figd(us)	Displays the Jitter Threshold Configured (in microseconds).
Jitter Mea- surd(us)	Displays the Jitter Measured (in microseconds).
Jitter Accep- tance	Displays Pass, Fail, or Not Applicable. It displays Pass, if the measured value is less than or equal to the configured threshold and displays "Fail" otherwise, and displays "Not Applicable", if the jitter criteria is not used to determine whether the test is in Passed or Failed status.
OutPrf Jit Conf(us)	Displays the out-of-profile Jitter configured.

Label	Description (Continued)
OutPrf Jit Meas (us)	Displays the out-of-profile Jitter measured.
OutPrf Jit Acep	Displays Pass, Fail, or Not Applicable. It displays Pass, if the measured value is less than or equal to the configured threshold and displays "Fail" otherwise, and displays "Not Applicable", if the out-of-profile jitter criteria is not used to determine whether the test is in Passed or Failed status.
InPrf Jit Conf (us)	Displays the in-profile Jitter configured.
InPrf Jit Meas (us)	Displays the in-profile Jitter measured.
InPrf Jit Acep	Displays Pass, Fail, or Not Applicable. It displays Pass, if the measured value is less than or equal to the configured threshold and displays "Fail" otherwise, and displays "Not Applicable", if the in-profile jitter criteria is not used to determine whether the test is in Passed or Failed status.
Total Pkts. Tx.	Total number of packets ( that is, data and marker) transmitted by the testhead session for the duration of the test.
OutPrf Latency Pkt*	Total number of out-of-profile marker packets received by the testhead session for the duration of the test.
Total Tx. Fail	Total number of failed transmission attempts by the testhead session for the duration of the test.
Latency Pkts. Tx	Total number of marker packets transmitted by the testhead session for the duration of the test.
InPrf Latency Pkt*	Total number of in-profile marker packets received by the testhead session for the duration of the test.

### Sample output

```
*A:7210SAS# show testhead test-me owner owner-me
```

```
=====
Y.1564 Testhead Session
=====
Owner          : owner-me
Test           : test-me
Profile Id     : 1                SAP           : 1/1/2:100
Accept. Crit. Id : 0                Completed      : Yes
Frame Payload Id : 1                Stopped       : No
Frame Payload Type : tcp-ipv4          FC            : be
Color Aware Test : Yes
Start Time     : 08/08/2001 19:37:11
End Time       : 08/08/2001 19:40:16
```

## OAM testhead commands

Total time taken : 0d 00:03:05

---

### Latency Results

---

(total pkts in us):	Min	Max	Average	Jitter
Roundtrip :	0	0	0	0
(OutPrf pkts in us):	Min	Max	Average	Jitter
Roundtrip :	0	0	0	0
(InPrf pkts in us):	Min	Max	Average	Jitter
Roundtrip :	0	0	0	0

---

### Packet Count

---

Total Injected : 42273637  
Total Received : 0

OutPrf Injected : 16898179  
OutPrf Received : 0

InPrf Injected : 25375450  
InPrf Received : 0

---

### Test Compliance Report

---

Throughput Configd : 962388  
Throughput Oper : 962384  
Throughput Measurd : 0

PIR Tput Threshld : Not configured  
PIR Tput Meas : 0

CIR Tput Threshld : Not configured  
CIR Tput Meas : 0

FLR Configured : None  
FLR Measurd : Not Applicable  
FLR Acceptance : Fail

OutPrf FLR Conf : None  
OutPrf FLR Meas : Not Applicable  
OutPrf FLR Acep : Not Applicable

InPrf FLR Conf : None  
InPrf FLR Meas : Not Applicable  
InPrf FLR Acep : Not Applicable

Latency Configd(us) : None  
Latency Measurd(us) : None  
Latency Acceptance : Not Applicable

OutPrf Lat Conf(us) : None  
OutPrf Lat Meas(us) : None  
OutPrf Lat Acep : Not Applicable



## Clear Commands

### saa

**Syntax** `saa-test [test-name [owner test-owner]]`

**Context** clear

**Description** Clear the SAA results for the latest and the history for this test. If the test name is omitted, all the results for all tests are cleared.

**Parameters** *test-name* — Name of the SAA test. The test name must already be configured in the `config>saa>test` context.

*owner test-owner* — Specifies the owner of an SAA operation up to 32 characters in length.

**Default** If a *test-owner* value is not specified, tests created by the CLI have a default owner “TiMOS CLI”.

### test-oam

**Syntax** `test-oam`

**Context** clear

**Description** Clears the Operations, Administration, and Maintenance test parameters

### twamp server

**Syntax** `twamp server`

**Context** clear>test-oam

**Description** Clear TWAMP server statistics.

### testhead

**Syntax** `testhead result [ test-name ] [owner test-owner]`

**Context** oam>clear

**Description** Clear the testhead results identified by the test-name and test-owner.

**Parameters** *result* — Clears the test results from the latest history for the test.

*test-name* — Name of the test

**Values** ASCII string upto 32 characters in length

*owner test-owner* — Specifies the owner of a testhead operation.

**Values** ASCII string upto 32 characters in length

## testhead

**Syntax** `testhead testhead-profile profile-id`

**Context** `oam>clear`

**Description** Clear the testhead results identified by the testhead-profile.

**Parameters** *testhead-profile profile-id* — Clears the testhead profile ID to use with this run/session of testhead invocation.

**Values** [1..10]



---

## Tools Command Reference

---

### Command Hierarchies

- [Tools Dump Commands on page 201](#)
- [Tools Perform Commands on page 202](#)

### Configuration Commands

#### Tools Dump Commands

```

tools
  — dump
    — accounting-policy acct-policy-id flash-write-count [clear]
    — eth-ring ring-index [clear]
    — lag lag-id lag-id
    — persistence
      — summary
        — mc-endpoint peer ip-address
    — router router-instance
      — dintf [ip-address]
      — filter-info [verbose]
      — l3info
      — l3-stats [clear]
      — service-name service-name
    — service
      — base-stats [clear]
      — dpipe service-id
      — dtls service-id
      — iom-stats [clear]
      — l2pt-diags
      — l2pt-diags clear
      — l2pt-diags detail
      — vpls-fdb-stats [clear]
      — vpls-mfib-stats [clear]
    — system
      — cpu-pkt-stats
    — system-resources slot-number
    — system-resources sap-ingress-qos

```

Tools Perform Commands

- tools**
  - **perform**
    - **cron**
      - **action**
        - **stop** *[action-name]* [**owner** *action-owner*] [**all**]
      - **tod**
        - **re-evaluate**
          - **customer** *customer-id* [**site** *customer-site-name*]
          - **filter ip-filter** *[filter-id]*
          - **filter ipv6-filter** *[filter-id]*
          - **filter mac-filter** *[filter-id]*
          - **service id** *service-id* [**sap** *sap-id*]
          - **tod-suite** *tod-suite-name*
  - **eth-cfm**
  - **lag**
    - **clear-force lag-id** *lag-id* [**sub-group** *sub-group-id*]
    - **force lag-id** *lag-id* [**sub-group** *sub-group-id*] { **active** | **standby** }
  - **log**
  - **test-event**

---

## Tools Configuration Commands

---

### Generic Commands

#### tools

**Syntax**    **tools**

**Context**    root

**Description**    This command enables the context to enable useful tools for debugging purposes.

**Default**    none

**Parameters**    **dump** — Enables dump tools for the various protocols.  
                  **perform** — Enables tools to perform specific tasks.

## Dump Commands

### dump

<b>Syntax</b>	<b>dump</b> <i>router-name</i>
<b>Context</b>	tools
<b>Description</b>	The context to display information for debugging purposes.
<b>Default</b>	none
<b>Parameters</b>	<i>router-name</i> — Specify a router name, up to 32 characters in length. <b>Default</b> Base

### accounting-policy

<b>Syntax</b>	accounting-policy <i>acct-policy-id</i> <b>flash-write-count</b> [clear]
<b>Context</b>	tools>dump
<b>Description</b>	The above command dumps the total count of flash writes for the accounting policy specified by the user. The 'clear' option allows the user to clear the count maintained per accounting policy and starts the counter afresh.
<b>Parameters</b>	<b>flash-write-count</b> — This is a keyword used to dump the total number of flash writes up to the present for the accounting policy specified by accounting-policy 'id'. <i>acct-policy-id</i> — Identifies the Accounting policy. <b>Values</b> 1 - 99 <b>clear</b> — This keyword clears statistics.

### eth-ring

<b>Syntax</b>	eth-ring <i>ring-index</i> [clear] <b>eth-ring control-sap-tag</b> <i>port-id</i> [ <b>list-in-use</b>   <b>next-available</b> ]
<b>Context</b>	tools>dump
<b>Description</b>	The command displays Ethernet-ring information.
<b>Parameters</b>	<i>ring-index</i> — Specify ring index. <b>Values</b> 1 —128 <b>clear</b> — This keyword clears statistics.

## lag

**Syntax** lag lag-id lag-id

**Context** tools>dump

**Description** This tool displays LAG information.

**Parameters** lag-id — Specify an existing LAG id.

**Values** 1 — 12

```
*A:7210 SAS>tools>dump# lag lag-id 1
Port state      : Up
Selected subgrp : 1
NumActivePorts  : 2
ThresholdRising : 2
ThresholdFalling: 0
IOM bitmask     : 2
Config MTU      : 1522
Oper. MTU       : 1522
Bandwidth       : 200000

multi-chassis   : NO
```

```
-----
Indx  PortId  RX pkts  TX pkts  State Active Port  Cfg Oper Speed      BW AP CS
-----
          Pri  Mtu Mtu
-----
  0   1/1/1      1      1    Up   yes 32768 1522 1522  1000  100000 0  2
  1   1/1/2      0      0    Up   yes 32768 1522 1522  1000  100000 0  2
-----
```

## persistence

**Syntax** persistence

**Context** tools>dump

**Description** This command enables the context to display persistence information for debugging purposes.

## summary

**Syntax** summary

**Context** tools>dump>persistence

**Description** The context to display persistence summary information for debugging purposes.

**Sample Output**

```
A:ALA-B# tools dump persistence summary
=====
```

## Dump Commands

```
Persistence Summary on Slot A
=====
Client           Location           Entries in use    Status
-----
xxxxxx          cf1:\l2_dhcp.pst  200              ACTIVE
-----
Persistence Summary on Slot B
=====
Client           Location           Entries in use    Status
-----
xxxxxx          cf1:\l2_dhcp.pst  200              ACTIVE
-----
A:ALA-B#
```

### system

**Syntax** **cpu-pkt-stats**

**Context** tools>dump>system

**Description** This command dumps tools for system information.

### cpu-pkt-stats

**Syntax** **cpu-pkt-stats**

**Context** tools>dump>system

**Description** This command dumps statistics for CPU traffic.

### system-resources

**Syntax** **system-resources** *slot-number*  
**system-resources** *sap-ingress-qos*

**Context** tools>dump

**Description** This command displays system resource information.

**Default** none

**Parameters** *slot-number* — Specify a specific slot to view system resources information.

#### Values

*sap-ingress-qos* — This command provides details on usage of resources allocated for QoS classification and different match criteria under QoS classification.

**tools dump system-resources sap-ingress-qos** — The following table describes tools dump system-resource sap-ingress-qos output fields:

**Table 10: Output fieldstools dump system-resource sap-ingress-qos**

Labels	Descriptions
Total Chunks Configured	Displays the total number of chunks configured for use by SAP ingress QoS classification across all the match criteria.
Total Chunks Available	Displays the total number of chunks allotted by software for use by SAP ingress QoS classification across all the match criteria.
Number of Chunks in Use	Displays the total number of chunks in use by SAP for SAP ingress QoS classification.
Number of Free Chunks	Displays the total number of chunks available for use by SAP for SAP ingress QoS classification.
Number of Chunks in use for IP match	Displays the total number of chunks in use for by SAP that use IP classification match criteria in the SAP ingress QoS policy.
Number of Chunks in use for IPv6 match	Displays the total number of chunks in use for by SAP that use IPv6 classification match criteria in the SAP ingress QoS policy.
Number of Chunks in use for MAC match	Displays the total number of chunks in use for by SAP that use MAC classification match criteria in the SAP ingress QoS policy.
Classification Entries	The total number of Classification entries that are available/allocated/free per chunk. Information is displayed only for chunks that are in use. <b>Meters</b> - The total number of Meters that are available/allocated/free per chunk. Information is displayed only for chunks that are in use.

**Table 10: Output fieldstools dump system-resource sap-ingress-qos**

Labels	Descriptions
Number of Chunks available for use with IP match criteria	Displays the total number of chunks in use for by SAP that use IP classification match criteria in the SAP ingress QoS policy. This assumes all of the free chunks are alloted to IP classification match criteria.
Number of Chunks available for use with IPv6 match criteria	Displays the total number of chunks in use for by SAP that use IPv6 classification match criteria in the SAP ingress QoS policy. This assumes all of the free chunks are alloted to IPv6 classification match criteria.
Number of Chunks available for use with MAC match criteria	Displays the total number of chunks in use for by SAP that use MAC classification match criteria in the SAP ingress QoS policy. This assumes all of the free chunks are alloted to MAC classification match criteria.

```
*A:7210-SAS>tools>dump# system-resources tools dump system-resources sap-ingress-qos
Sap Resource Manager info at 001 d 10/11/12 04:42:00.043:
```

Sap Ingress Resource Usage for Slot #1, Cmplx #0:

```
Total Chunks Configured : 6
Total Chunks Available : 6
Number of Chunks in Use : 1
Number of Free Chunks : 5
Number of Chunks in use for IP match : 0
Number of Chunks in use for IPv6 match : 0
Number of Chunks in use for MAC match : 1
```

Chunk	Type	Classification Entries			Meters		
		Total	Allocated	Free	Total	Allocated	Free
0	Mac	512	2	510	256	1	255

```
Number of Chunks available for use with IP match* : 5
Number of Chunks available for use with IPv6 match* : 0
Number of Chunks available for use with MAC match* : 5
```

\* - Assumes all remaining chunks are used  
 \*A:Dut-A>tools>dump#

**tools dump system-resources sap-egress-aggregate-meter** — The following table describes tools dump system-resource sap-egress-aggregate-meter output fields:

```
*7210SAS>config>service# /tools dump system-resources
Resource Manager info at 022 h 07/27/01 22:50:44.676:
```

Hardware Resource Usage per Node:

	Total	Allocated	Free
-----+-----+-----			

Max System Ecmp Routes | | 1|

Hardware Resource Usage for Slot #1, CardType iom-sas, Cmplx #0:

	Total	Allocated	Free
SAP Ingress QoS Policies	1791	1	1790
Access Egr. QoS Policies	255	1	254
SAP Ingress Aggregate-Meter	256	0	256
Shared Qos Ingress Meters	1280	256	1024
Shared Qos Ingress CAM Entries	2560	512	2048
Mac Qos Ingress Meters	256	2	254
Mac Qos Ingress CAM Entries	512	4	508
IPv4 Qos Ingress Meters	0	0	0
IPv4 Qos Ingress CAM Entries	0	0	0
IPv6 Qos Ingress Meters	0	0	0
IPv6 Qos Ingress CAM Entries	0	0	0
IP + Mac Qos Ingress Meters	0	0	0
IP + Mac Qos Ingress CAM Entries	0	0	0
SAP Egress Aggregate-Meter Entries	512	2	510
Network Ingress Meters	256	0	256
Network Ing CAM Entries	512	0	512
Port Scheduler Policies	1023	1	1022
Ingress Shared ACL Entries	2560	0	2560
Ingress Mac ACL Entries	0	0	0
Ingress IPv4 ACL Entries	0	0	0
Ing IPv6 128 bit ACL Entries	0	0	0
Ing IPv6 64 bit ACL Entries	0	0	0
Egress Shared ACL Entries	0	0	0
Egress Mac only ACL Entries	0	0	0
Egress Mac+IPv4 ACL Entries	0	0	0
Egr IPv6 128 bit ACL Entries	0	0	0
Egr Mac+IPv6 64 bit ACL Entries	0	0	0
Ingress SAP Lookup Entries	1496	4	1492
Num VLAN-ID/Range in Con Profile	4096	0	4096

## Service Commands

### service

**Syntax** `service`

**Context** `tools>dump`

**Description** Use this command to configure tools to display service dump information.

### base-stats

**Syntax** `base-stats [clear]`

**Context** `tools>dump>service`

**Description** Use this command to display internal service statistics.

**Default** `none`

**Parameters** `clear` — Clears stats after reading.

### dpipe

**Syntax** `dpipe service-id`

**Context** `tools>dump>service`

**Description** This command displays debug information for specified service.

**Parameters** `service-id` — Displays specified service ID details.

### dtls

**Syntax** `dtls service-id`

**Context** `tools>dump>service`

**Description** Use this command to display TLS service statistics.

**Default** `none`

**Parameters** `service-id` — Displays specified service ID details.

## iom-stats

<b>Syntax</b>	<b>iom-stats [clear]</b>
<b>Context</b>	tools>dump>service
<b>Description</b>	Use this command to display IOM message statistics.
<b>Default</b>	none
<b>Parameters</b>	<b>clear</b> — Clears stats after reading.

## l2pt-diags

<b>Syntax</b>	<b>l2pt-diags</b> <b>l2pt-diags clear</b> <b>l2pt-diags detail</b>
<b>Context</b>	tools>dump>service
<b>Description</b>	Use this command to display L2pt diagnostics.
<b>Default</b>	none
<b>Parameters</b>	<b>clear</b> — Clears the diags after reading. <b>detail</b> — Displays detailed information.

**Sample Output**

```
A:ALA-48>tools>dump>service# l2pt-diags
[ l2pt/bpdu error diagnostics ]
  Error Name          | Occurrence   | Event log
  -----+-----+-----
[ l2pt/bpdu forwarding diagnostics ]

  Rx Frames   | Tx Frames   | Frame Type
  -----+-----+-----
A:ALA-48>tools>dump>service#

A:ALA-48>tools>dump>service# l2pt-diags detail
[ l2pt/bpdu error diagnostics ]
  Error Name          | Occurrence   | Event log
  -----+-----+-----
[ l2pt/bpdu forwarding diagnostics ]

  Rx Frames   | Tx Frames   | Frame Type
  -----+-----+-----
[ l2pt/bpdu config diagnostics ]
WARNING - service 700 has l2pt termination enabled on all access points :
         consider translating further down the chain or turning it off.
WARNING - service 800 has l2pt termination enabled on all access points :
         consider translating further down the chain or turning it off.
WARNING - service 9000 has l2pt termination enabled on all access points :
         consider translating further down the chain or turning it off.
WARNING - service 32806 has l2pt termination enabled on all access points :
```

## Service Commands

```
consider translating further down the chain or turning it off.  
WARNING - service 90001 has l2pt termination enabled on all access points :  
consider translating further down the chain or turning it off.  
A:ALA-48>tools>dump>service#
```

### vpls-fdb-stats

**Syntax** `vpls-fdb-stats [clear]`

**Context** `tools>dump>service`

**Description** Use this command to display VPLS FDB statistics.

**Default** none

**Parameters** `clear` — Clears stats after reading.

### vpls-mfib-stats

**Syntax** `vpls-mfib-stats [clear]`

**Context** `tools>dump>service`

**Description** Use this command to display VPLS MFIB statistics.

**Default** none

**Parameters** `clear` — Clears stats after reading.

## Router Commands

### router

<b>Syntax</b>	<b>router</b> <i>router-instance</i>				
<b>Context</b>	tools>dump				
<b>Description</b>	This command enables tools for the router instance.				
<b>Default</b>	none				
<b>Parameters</b>	<b>router</b> <i>router-instance</i> — Specifies the router name or service ID.				
<b>Values</b>	<table> <tr> <td><i>router-name:</i></td> <td>Base</td> </tr> <tr> <td><i>service-id:</i></td> <td>1 — 2147483647</td> </tr> </table>	<i>router-name:</i>	Base	<i>service-id:</i>	1 — 2147483647
<i>router-name:</i>	Base				
<i>service-id:</i>	1 — 2147483647				
<b>Default</b>	Base				

### dintf

<b>Syntax</b>	<b>dintf</b> [ <i>ip-address</i> ]
<b>Context</b>	tools>dump
<b>Description</b>	<p>This command displays the internal IP interface details.</p> <p>This command dumps hardware-specific information related to the active IP interfaces configured. By default, hardware information for all active IP interfaces is dumped.</p>
<b>Default</b>	Dumps hardware-specific information for all the active IP interfaces present within the system.
<b>Parameters</b>	<i>ip-address</i> — Only displays the hardware information associated with the specified IP address.

#### Sample Output

```
A:STU# /tools dump router dintf 5.1.1.2
[***** SLOT 1 *****]
[IP interfaces]
Table Usage:                5/263
[L3 SAP interface 1/1/7:360137680]
Interface index              54 (Svc)
cpmtag                       2
primary IPv4                 5.1.1.2/24
VRF                           0
primary MAC                  00:14:25:36:f7:f0
no VRRP MAC addresses
Local Subnet 0               5.1.1.2/24 index=62
admin ip_mtu                 1500
Intf Port                    1/1/7
No agg port
```

## Router Commands

```

uRPF mode                               None
Ingress uRPF stats                       Drop=0/0
[Host IP Map 1 entries]
  [IP Entry v4 5.1.1.1 interface=54 L3 Egress HDL=100003 Ref Cnt=0]
    [Nexthop 5.1.1.1 idx=7]
      ref count                           1
      # mpls nhlfes                        0
      # nexthop groups                     1
      # SDP bindings                       0
      p2mp_arp_index                      0
Subscriber ifIndex                        0
Subscriber red ifIndex                    0
[Subscriber Red Group 54]
  Subscriber red ifIndex                  0
  Subscriber use SRRP src mac             no
  Use inter-dest Id                      no
  SRRP                                    Disabled
  ref count                               1
  [Inter-dest group 0]
    Locally reachable                     no
    Subscriber red ifIndex                 In-use=no
    Subscriber hosts unreachable          no
    cpmtag                                 15
  cpmtag                                  15
  L3 SAP                                  idx=1 1/1/7:0.*
SVLAN                                     54
svlan_interface_index                    54
Encap Type                                q-in-q
HW IF Index                               1024
L2 USER ENTRY cindex                     1
VFP EID                                   181
L3 BCAST EID                              182
ARP REPLY EID                             183
ARP REQST EID                             184
VFP0 EID                                   185
L3 BCAST0 EID                             186
ARP REPLY0 EID                            187
ARP REQST0 EID                            188
L3 BCAST IFP                              189
ARP IFP                                   190
IP EXT Mtch IFP                           288
HW Port Number                            17
A:STU#
A:ALA-A#

```

## filter-info

**Syntax** `filter-info [verbose]`

**Context** `tools>dump>router`

**Description** This command dumps the hardware-specific filter information.

**Parameters** `verbose` — Displays the hardware information of the filter.

## l3info

**Syntax** lag

**Context** tools>dump>router

**Description** This command dumps the hardware-specific L3 information.

## l3-stats

**Syntax** l3-stats [clear]

**Context** tools>dump>router

**Description** This command dumps the hardware-specific L3 statistics.

**Parameters** clear — Clears the hardware information of the filter.

## eth-cfm

**Syntax** eth-cfm

**Context** tools>perform

**Description** This command configures performance tools for eth-cfm.

## eth-cfm

**Syntax** eth-cfm

**Context** tools>perform

**Description** This command configures performance tools for eth-cfm.

## lag

**Syntax** lag

**Context** tools>perform

**Description** This command configures tools to control LAG.

## log

<b>Syntax</b>	<b>log</b>
<b>Context</b>	tools>perform
<b>Description</b>	Tools for event logging.

## test-event

<b>Syntax</b>	<b>test-event</b>
<b>Context</b>	tools>perform>log
<b>Description</b>	This command causes a test event to be generated. The test event is LOGGER event #2011 and maps to the tmnxEventSNMP trap in the TIMETRA-LOG-MIB.

## cspf

<b>Syntax</b>	<b>cspf to</b> ip-addr [ <b>from</b> ip-addr] [ <b>strict-srlg</b> ] [ <b>srlg-group</b> grp-id...(up to 8 max)] [ <b>bandwidth</b> bandwidth] [ <b>include-bitmap</b> bitmap] [ <b>exclude-bitmap</b> bitmap] [ <b>hop-limit</b> limit] [ <b>exclude-address</b> excl-addr [excl-addr...(upto 8 max)]] [ <b>use-te-metric</b> ] [ <b>exclude-node</b> excl-node-id [excl-node-id...(upto 8 max)]] [ <b>skip-interface</b> interface-name]
<b>Context</b>	tools>perform>router>mpls
<b>Description</b>	This command computes a CSPF path with specified user constraints.
<b>Default</b>	none
<b>Parameters</b>	<b>to</b> <i>ip-addr</i> — Specify the destination IP address. <b>from</b> <i>ip-addr</i> — Specify the originating IP address. <b>srlg-group</b> <i>grp-id</i> — Specify the <b>bandwidth</b> <i>bandwidth</i> — Specifies the amount of bandwidth in mega-bits per second (Mbps) to be reserved. <b>include-bitmap</b> <i>bitmap</i> — Specifies to include a bit-map that specifies a list of admin groups that should be included during setup. <b>exclude-bitmap</b> <i>bitmap</i> — Specifies to exclude a bit-map that specifies a list of admin groups that should be included during setup. <b>hop-limit</b> <i>limit</i> — Specifies the total number of hops a detour LSP can take before merging back onto the main LSP path. <b>exclude-address</b> <i>ip-addr</i> — Specifies an IP address to exclude from the operation. <b>use-te-metric</b> — Specifies whether the TE metric would be used for the purpose of the LSP path computation by CSPF.

**skip-interface** *interface-name* — Specifies a local interface name, instead of the interface address, to be excluded from the CSPF computation.

## force-switch-path

**Syntax** **force-switch-path** **lsp** *lsp-name* **path** *path-name*  
**no force-switch-path** **lsp** *lsp-name*

**Context** tools>perform>router>mpls

### Description

## resignal

**Syntax** **resignal** **lsp** *lsp-name* **path** *path-name* **delay** *minutes*  
**resignal** {**p2mp-lsp** *p2mp-lsp-name* **p2mp-instance** *p2mp-instance-name* | **p2mp-delay** *p2mp-minutes*}

**Context** tools>perform>router>mpls

**Description** Use this command to resignal a specific LSP path.

**Default** none

**Parameters** **lsp** *lsp-name* — Specifies the name that identifies the LSP. The LSP name can be up to 32 characters long and must be unique.

**path** *path-name* — Specifies the name for the LSP path up to 32 characters in length.

**delay** *minutes* — Specifies the resignal delay in minutes.

**Values** 0 — 30

**p2mp-lsp** *p2mp-lsp-name* — Specifies an existing point-to-multipoint LSP name.

**p2mp-instance** *p2mp-instance-name* — Specifies a name that identifies the P2MP LSP instance

**p2mp-delay** *p2mp-minutes* — Specifies the delay time, in minutes.

**Values** 0 — 60

## switch-path

**Syntax** **switch-path** **lsp** *lsp-name* **path** *path-name*

**Context** tools>perform>router>mpls

**Description**

trap-suppress

**Syntax** **trap-suppress** [*number-of-traps*] [*time-interval*]

**Context** tools>perform>router>mpls

**Description** This command modifies thresholds for trap suppression.

**Default** none

**Parameters** *number-of-traps* — Specify the number of traps in multiples of 100. An error messages is generated if an invalid value is entered.

**Values** 100 to 1000

*time-interval* — Specify the timer interval in seconds.

**Values** 1 — 300

tp-tunnel

**Syntax** **tp-tunnel**

**Context** tools>perform>router>mpls

**Description** This command enables the context to perform Linear Protection operations on an MPLS-TP LSP.

clear

**Syntax** **clear** {*lsp-name* | **id** *tunnel-id*}

**Context** tools>perform>router>mpls>tp-tunnel

**Description** Clears all the MPLS-TP linear protection operational commands for the specified LSP that are currently active.

**Parameters** *lsp-name* — Specifies the name of the MPLS-TP LSP.

**Values** up to 32 characters in text

**id** *tunnel-id* — Specifies the tunnel number of the MPLS-TP LSP

**Values** 1 — 61440

force

**Syntax** **force** {*lsp-name* | **id** *tunnel-id*}

Context tools>perform>router>mpls>tp-tunnel

**Description** Performs a force switchover of the MPLS-TP LSP from the active path to the protect path.

**Parameters** *lsp-name* — Specifies the name of the MPLS-TP LSP.

**Values** up to 32 characters in text

**id tunnel-id** — Specifies the tunnel number of the MPLS-TP LSP

**Values** 1 — 61440

## manual

**Syntax** manual {*lsp-name* | **id tunnel-id**}

Context tools>perform>router>mpls>tp-tunnel

**Description** Performs a manual switchover of the MPLS-TP LSP from the active path to the protect path.

**Parameters** *lsp-name* — Specifies the name of the MPLS-TP LSP.

**Values** up to 32 characters in text

**id tunnel-id** — Specifies the tunnel number of the MPLS-TP LSP

**Values** 1 — 61440

## lockout

**Syntax** lockout {*lsp-name* | **id tunnel-id**}

Context tools>perform>router>mpls>tp-tunnel

**Description** Performs a lockout of protection for an MPLS-TP LSP. This prevents a switchover to the protect path.

**Parameters** *lsp-name* — Specifies the name of the MPLS-TP LSP.

**Values** up to 32 characters in text

**id tunnel-id** — Specifies the tunnel number of the MPLS-TP LSP

**Values** 1 — 61440

## ospf3

**Syntax** ospf3

**Context** tools>dump>router

**Description** This command enables the context to display tools information for OSPF3.

**Default** none

## Performance Tools

### perform

**Syntax** perform

**Context** tools

**Description** This command enables the context to enable tools to perform specific tasks.

**Default** none

### cron

**Syntax** cron

**Context** tools>perform

**Description** This command enables the context to perform CRON (scheduling) control operations.

**Default** none

### action

**Syntax** action

**Context** tools>perform>cron

**Description** This command enables the context to stop the execution of a script started by CRON action. See the **stop** command.

### stop

**Syntax** stop [*action-name*] [**owner** *action-owner*] [**all**]

**Context** tools>perform>cron>action

**Description** This command stops execution of a script started by CRON action.

**Parameters** *action-name* — Specifies the action name.

**Values** Maximum 32 characters.

**owner** *action-owner* — Specifies the owner name.

**Default** TiMOS CLI

**all** — Specifies to stop all CRON scripts.

## tod

<b>Syntax</b>	<b>tod</b>
<b>Context</b>	tools>perform>cron
<b>Description</b>	This command enables the context for tools for controlling time-of-day actions.
<b>Default</b>	none

## re-evaluate

<b>Syntax</b>	<b>re-evaluate</b>
<b>Context</b>	tools>perform>cron>tod
<b>Description</b>	This command enables the context to re-evaluate the time-of-day state.
<b>Default</b>	none

## customer

<b>Syntax</b>	<b>customer</b> <i>customer-id</i> [ <b>site</b> <i>customer-site-name</i> ]
<b>Context</b>	tools>perform>cron>tod>re-eval
<b>Description</b>	This command re-evaluates the time-of-day state of a multi-service site.
<b>Parameters</b>	<i>customer-id</i> — Specify an existing customer ID. <b>Values</b> 1 — 2147483647 <i>site customer-site-name</i> — Specify an existing customer site name.

## filter

<b>Syntax</b>	<b>filter</b> <i>ip-filter</i> [ <i>filter-id</i> ] <b>filter</b> <i>ipv6-filter</i> [ <i>filter-id</i> ] <b>filter</b> <i>mac-filter</i> [ <i>filter-id</i> ]
<b>Context</b>	tools>perform>cron>tod>re-eval
<b>Description</b>	This command re-evaluates the time-of-day state of a filter entry.
<b>Parameters</b>	<i>filter-type</i> — Specify the filter type. <b>Values</b> ip-filter, mac-filter <i>filter-id</i> — Specify an existing filter ID. <b>Values</b> 1 — 65535

## service

**Syntax** `service id service-id [sap sap-id]`

**Context** `tools>perform>cron>tod>re-eval`

**Description** This command re-evaluates the time-of-day state of a SAP.

**Parameters** `r service-id` — Specify the an existing service ID.

**Values** 1 — 2147483647

`sap sap-id` — Specifies the physical port identifier portion of the SAP definition. See [Common CLI Command Descriptions on page 223](#) for CLI command syntax.

## tod-suite

**Syntax** `tod-suite tod-suite-name`

**Context** `tools>perform>cron>tod>re-eval`

**Description** This command re-evaluates the time-of-day state for the objects referring to a tod-suite.

**Parameters** `tod-suite-name` — Specify an existing TOD nfname.

# Common CLI Command Descriptions

---

## In This Chapter

This chapter provides CLI syntax and command descriptions for SAP and port commands.

Topics in this chapter include:

- [SAP Syntax on page 224](#)
- [Port Syntax on page 202](#)

## Common Service Commands

### sap

**Syntax** [no] **sap** *sap-id*

**Description** This command specifies the physical port identifier portion of the SAP definition.

**Parameters** *sap-id* — Specifies the physical port identifier portion of the SAP definition.

The *sap-id* can be configured in one of the following formats:

Type	Syntax	Example
port-id	<i>slot/mda/port[.channel]</i>	1/1/5
null	<i>[port-id lag-id]</i>	<i>port-id:</i> 1/1/3 <i>lag-id:</i> lag-3
dot1q	<i>[port-id  lag-id]:qtag1</i>	<i>port-id:qtag1:</i> 1/1/3:100 <i>lag-id:qtag1:</i> lag-3:102
qinq	<i>[port-id   lag-id]:qtag1.qtag2</i>	<i>port-id:qtag1.qtag2:</i> 1/1/3:100.10 <i>lag-id:qtag1.qtag2:</i> lag-10

### port

**Syntax** **port** *port-id*

**Description** This command specifies a port identifier.

**Parameters** *port-id* — The *port-id* can be configured in one of the following formats.

*port-id*                    *slot/mda/port*

# Standards and Protocol Support

---

## Standards Compliance

IEEE 802.1ab-REV/D3 Station and Media Access Control Connectivity Discovery  
IEEE 802.1d Bridging  
IEEE 802.1p/Q VLAN Tagging  
IEEE 802.1s Multiple Spanning Tree  
IEEE 802.1w Rapid Spanning Tree Protocol  
IEEE 802.1x Port Based Network Access Control  
IEEE 802.1ad Provider Bridges  
IEEE 802.1ag Service Layer OAM  
IEEE 802.3ah Ethernet in the First Mile  
IEEE 802.3 10BaseT  
IEEE 802.3ad Link Aggregation  
IEEE 802.3u 100BaseTX  
IEEE 802.3z 1000BaseSX/LX  
ITU-T Y.1731 OAM functions and mechanisms for Ethernet based networks  
IANA-IFType-MIB  
IEEE8023-LAG-MIB  
ITU-T G.8032 Ethernet Ring Protection Switching (version 2)

## Protocol Support

### DHCP

RFC 2131 Dynamic Host Configuration Protocol  
RFC 3046 DHCP Relay Agent Information Option (Option 82)

### DIFFERENTIATED SERVICES

RFC 2474 Definition of the DS Field the IPv4 and IPv6 Headers (Rev)  
RFC 2597 Assured Forwarding PHB Group (rev3260)  
RFC 2598 An Expedited Forwarding PHB  
RFC 3140 Per-Hop Behavior Identification Codes  
RFC 4115 A Differentiated Service Two-Rate, Three-Color Marker with

Efficient Handling of in-Profile Traffic [Only for 7210 SAS-D]

### IPv6 (only 7210 SAS-D and 7210 SAS-E)

RFC 2460 Internet Protocol, Version 6 (IPv6) Specification  
RFC 2461 Neighbor Discovery for IPv6  
RFC 2462 IPv6 Stateless Address Auto configuration  
RFC 2463 Internet Control Message Protocol (ICMPv6) for the Internet Protocol Version 6 Specification  
RFC 2464 Transmission of IPv6 Packets over Ethernet Networks  
RFC 3587 IPv6 Global Unicast Address Format  
RFC 4007 IPv6 Scoped Address Architecture  
RFC 4193 Unique Local IPv6 Unicast Addresses  
RFC 4291 IPv6 Addressing Architecture  
RFC 5095 Deprecation of Type 0 Routing Headers in IPv6

### Multicast (only 7210 SAS-D and 7210 SAS-E)

RFC 1112 Host Extensions for IP Multicasting (Snooping)  
RFC 2236 Internet Group Management Protocol, (Snooping)  
RFC 3376 Internet Group Management Protocol, Version 3 (Snooping)

### NETWORK MANAGEMENT

ITU-T X.721: Information technology-OSI-Structure of Management Information  
ITU-T X.734: Information technology-OSI-Systems Management: Event Report Management Function  
M.3100/3120 Equipment and Connection Models  
TMF 509/613 Network Connectivity Model  
RFC 1157 SNMPv1

RFC 1215 A Convention for Defining Traps for use with the SNMP  
RFC 1907 SNMPv2-MIB  
RFC 2011 IP-MIB  
RFC 2012 TCP-MIB  
RFC 2013 UDP-MIB  
RFC 2096 IP-FORWARD-MIB  
RFC 2138 RADIUS  
RFC 2571 SNMP-FRAMEWORKMIB  
RFC 2572 SNMP-MPD-MIB  
RFC 2573 SNMP-TARGET-&-NOTIFICATION-MIB  
RFC 2574 SNMP-USER-BASED-SMMIB  
RFC 2575 SNMP-VIEW-BASED-ACM-MIB  
RFC 2576 SNMP-COMMUNITY-MIB  
RFC 2665 EtherLike-MIB  
RFC 2819 RMON-MIB  
RFC 2863 IF-MIB  
RFC 2864 INVERTED-STACK-MIB  
RFC 3014 NOTIFICATION-LOGMIB  
RFC 3164 Syslog  
RFC 3273 HCRMON-MIB  
RFC 3411 An Architecture for Describing Simple Network Management Protocol (SNMP) Management Frameworks  
RFC 3412 Message Processing and Dispatching for the Simple Network Management Protocol (SNMP)  
RFC 3413 Simple Network Management Protocol (SNMP) Applications  
RFC 3414 User-based Security Model (USM) for version 3 of the Simple Network Management Protocol (SNMPv3)  
RFC 3418 SNMP MIB draft-ietf-disman-alarm-mib-04.txt  
RFC 3418 SNMP MIB

### RADIUS

RFC 2865 Remote Authentication Dial In User Service  
RFC 2866 RADIUS Accounting

## Standards and Protocols

### SSH

draft-ietf-secsh-architecture.txt SSH Protocol Architecture  
draft-ietf-secsh-userauth.txt SSH Authentication Protocol  
draft-ietf-secsh-transport.txt SSH Transport Layer Protocol  
draft-ietf-secsh-connection.txt SSH Connection Protocol  
draft-ietf-secsh-newmodes.txt SSH Transport Layer Encryption Modes

### TACACS+

draft-grant-tacacs-02.txt

### TCP/IP

RFC 768 UDP  
RFC 1350 The TFTP Protocol  
RFC 791 IP  
RFC 792 ICMP  
RFC 793 TCP  
RFC 826 ARP  
RFC 854 Telnet  
RFC 1519 CIDR  
RFC 1812 Requirements for IPv4 Routers  
RFC 2347 TFTP option Extension  
RFC 2328 TFTP Blocksize Option  
RFC 2349 TFTP Timeout Interval and Transfer Size option

### Timing (Only on 7210 SAS-D ETR and 7210 SAS-K)

ITU-T G.781 Telecommunication Standardization Section of ITU, Synchronization layer functions, issued 09/2008  
ITU-T G.813 Telecommunication Standardization Section of ITU, Timing characteristics of SDH equipment slave clocks (SEC), issued 03/2003.  
GR-1244-CORE Clocks for the Synchronized Network: Common Generic Criteria, Issue 3, May 2005  
ITU-T G.8261 Telecommunication Standardization Section of ITU, Timing and synchronization aspects in packet networks, issued 04/2008.  
ITU-T G.8262 Telecommunication Standardization Section of ITU, Timing characteristics of

synchronous Ethernet equipment slave clock (EEC), issued 08/2007.  
ITU-T G.8264 Telecommunication Standardization Section of ITU, Distribution of timing information through packet networks, issued 10/2008.  
IEEE Std 1588™-2008, IEEE Standard for a Precision Clock Synchronization Protocol for Networked Measurement and Control Systems.

### Proprietary MIBs

ALCATEL-IGMP-SNOOPING-MIB.mib  
TIMETRA-CAPABILITY-7210-SAS-E-V5v0.mib (Only for 7210 SAS-E)  
TIMETRA-CAPABILITY-7210-SAS-D-V5v0.mib (Only for 7210 SAS-D)  
TIMETRA-CHASSIS-MIB.mib  
TIMETRA-CLEAR-MIB.mib  
TIMETRA-DOT3-OAM-MIB.mib  
TIMETRA-FILTER-MIB.mib  
TIMETRA-GLOBAL-MIB.mib  
TIMETRA-IEEE8021-CFM-MIB.mib  
TIMETRA-LAG-MIB.mib (only on 7210 SAS-D,E)  
TIMETRA-LOG-MIB.mib  
TIMETRA-MIRROR-MIB.mib  
TIMETRA-NTP-MIB.mib  
TIMETRA-OAM-TEST-MIB.mib  
TIMETRA-PORT-MIB.mib  
TIMETRA-QOS-MIB.mib  
TIMETRA-SAS-ALARM-INPUT-MIB.mib  
TIMETRA-SAS-FILTER-MIB.mib  
TIMETRA-SAS-IEEE8021-CFM-MIB.mib  
TIMETRA-SAS-GLOBAL-MIB.mib  
TIMETRA-SAS-LOG-MIB.mib.mib  
TIMETRA-SAS-MIRROR-MIB.mib  
TIMETRA-SAS-PORT-MIB.mib  
TIMETRA-SAS-QOS-MIB.mib  
TIMETRA-SAS-SYSTEM-MIB.mib  
TIMETRA-SCHEDULER-MIB.mib  
TIMETRA-SECURITY-MIB.mib  
TIMETRA-SERV-MIB.mib  
TIMETRA-SYSTEM-MIB.mib  
TIMETRA-TC-MIB.mib  
TIMETRA-VRTR-MIB.mib

# Index

## C

[continuity check](#) 73

## E

[Ethernet CFM](#) 62

## L

[linktrace](#) 71

[loopback](#) 70

## M

### Mirror

[overview](#) 14

[implementation](#) 15

[source and destination](#) 16

[configuring](#)

[basic](#) 26

[classification rules](#) 27

[IP filter](#) 28

[MAC filter](#) 28

[port](#) 27

[SAP](#) 27

[command reference](#) 37

[local mirror service](#) 30

[management tasks](#) 32

[overview](#) 24

## O

[OAM](#) 60

[overview](#) 60

[configuring](#)

[command reference](#) 109

## S

[SAA test parameters](#) 93

[service assurance agent](#) 91, 94

## T

[Tools](#) 201