



# Alcatel-Lucent

Service Access Switch | Release 8.0 Rev.04

7210 SAS M, T, X, R6, R12, Mxp  
OAM and Diagnostics Guide

3HE10391AAACTQZZA



Alcatel-Lucent - Proprietary & Confidential

Contains proprietary/trade secret information which is the property of Alcatel-Lucent. Not to be made available to, or copied or used by anyone who is not an employee of Alcatel-Lucent except when there is a valid nondisclosure agreement in place which covers such information and contains appropriate non-disclosure and limited use obligations.

Copyright 2015 © Alcatel-Lucent. All rights reserved. All specifications, procedures, and information in this document are subject to change and revision at any time without notice. The information contained herein is believed to be accurate as of the date of publication. AlcatelLucent



---

All specifications, procedures, and information in this document are subject to change and revision at any time without notice. The information contained herein is believed to be accurate as of the date of publication. Alcatel-Lucent provides no warranty, express or implied, regarding its contents. Users are fully responsible for application or use of the documentation.

Alcatel, Lucent, Alcatel-Lucent and the Alcatel-Lucent logo are trademarks of Alcatel-Lucent. All other trademarks are the property of their respective owners.

Copyright 2015 Alcatel-Lucent.

All rights reserved.

### **Disclaimers**

Alcatel-Lucent products are intended for commercial uses. Without the appropriate network design engineering, they must not be sold, licensed or otherwise distributed for use in any hazardous environments requiring fail-safe performance, such as in the operation of nuclear facilities, aircraft navigation or communication systems, air traffic control, direct life-support machines, or weapons systems, in which the failure of products could lead directly to death, personal injury, or severe physical or environmental damage. The customer hereby agrees that the use, sale, license or other distribution of the products for any such application without the prior written consent of Alcatel-Lucent, shall be at the customer's sole risk. The customer hereby agrees to defend and hold Alcatel-Lucent harmless from any claims for loss, cost, damage, expense or liability that may arise out of or in connection with the use, sale, license or other distribution of the products in such applications.

This document may contain information regarding the use and installation of non-Alcatel-Lucent products. Please note that this information is provided as a courtesy to assist you. While Alcatel-Lucent tries to ensure that this information accurately reflects information provided by the supplier, please refer to the materials provided with any non-Alcatel-Lucent product and contact the supplier for confirmation. Alcatel-Lucent assumes no responsibility or liability for incorrect or incomplete information provided about non-Alcatel-Lucent products.

However, this does not constitute a representation or warranty. The warranties provided for Alcatel-Lucent products, if any, are set forth in contractual documentation entered into by Alcatel-Lucent and its customers.

This document was originally written in English. If there is any conflict or inconsistency between the English version and any other version of a document, the English version shall prevail.

# Table of Contents

<b>Preface</b> .....	9
<b>Getting Started</b>	
Alcatel-Lucent 7210 SAS-Series Services Configuration Process .....	13
<b>Mirror Services</b>	
Service Mirroring .....	16
Mirror Implementation .....	17
Mirror Source and Destinations .....	18
Mirroring Performance .....	21
Mirroring Configuration .....	22
Configuration Process Overview .....	24
Configuration Notes .....	25
Configuring Service Mirroring with CLI .....	27
Mirror Configuration Overview .....	28
Defining Mirrored Traffic .....	28
Basic Mirroring Configuration .....	30
Mirror Classification Rules .....	31
Common Configuration Tasks .....	33
Configuring a Local Mirror Service .....	34
Configuring a Remote Mirror Service .....	36
Service Management Tasks .....	40
Modifying a Local Mirrored Service .....	41
Deleting a Local Mirrored Service .....	42
Modifying a Remote Mirrored Service .....	43
Deleting a Remote Mirrored Service .....	45
Configuration Commands .....	51
<b>OAM and SAA</b>	
OAM Overview .....	74
Two-Way Active Measurement Protocol (TWAMP) .....	74
Configuration Notes .....	75
LSP Diagnostics .....	75
SDP Diagnostics .....	76
SDP Ping .....	76
SDP MTU Path Discovery .....	76
Service Diagnostics .....	77
VPLS MAC Diagnostics .....	78
MAC Ping .....	78
MAC Trace .....	79
CPE Ping .....	80
MAC Populate .....	81
MAC Purge .....	81
VLL Diagnostics .....	82
VCCV Ping .....	82

## Table of Contents

Automated VCCV-Trace Capability for MS-Pseudowire	85
MPLS-TP On-Demand OAM Commands (Supported only on 7210 SAS-R6, 7210 SAS-R12 and 7210 SAS-T)	89
MPLS-TP Pseudowires: VCCV-Ping/VCCV-Trace	89
MPLS-TP LSPs: LSP-Ping/LSP Trace	90
MPLS-TP Show Commands	92
Static MPLS Labels	92
MPLS-TP Tunnel Configuration	92
MPLS-TP Path configuration	93
MPLS-TP Protection	97
BFD	97
MPLS TP Node Configuration	99
MPLS-TP Interfaces	101
Services using MPLS-TP PWs	101
MPLS-TP DEBUG COMMANDS	104
Ethernet Connectivity Fault Management (ETH-CFM)	107
ETH-CFM Building Blocks	109
Loopback	122
Linktrace	123
Continuity Check (CC)	125
Alarm Indication Signal (ETH-AIS Y.1731)	127
Test (ETH-TST Y.1731)	127
Y.1731 Time Stamp Capability	127
Synthetic Loss Measurement (ETH-SL)	130
Configuration Example	132
ETH-CFM QoS Considerations	136
Configuration guidelines	136
OAM Mapping	137
CFM Connectivity Fault Conditions	137
CFM Fault Propagation Methods	138
Epipe Services	140
Fault Propagation to access dot1q/QinQ ports in Access-uplink mode	142
Configuring Fault propagation	143
Service Assurance Agent Overview	145
Traceroute Implementation	145
NTP	145
Writing SAA Results to Accounting Files	146
Configuring SAA Test Parameters	146
Y.1564 Testhead OAM tool	148
Pre-requisites for using the Testhead Tool	152
Generic pre-requisites for use of testhead tool (applicable for all 7210 SAS platforms):	152
Configuration Guidelines	155
Configuring testhead tool parameters	159
Diagnostics Command Reference	161
Tools Command Reference	303
<b>Common CLI Command Descriptions</b>	
Common Service Commands	346

**Standards and Protocol Support** .....347

Table of Contents

# List of Tables

<b>Preface</b> .....	9
<b>Getting Started</b>	
Table 1: Configuration Process .....	13
<b>Mirror Services</b>	
Table 2: Combinations of SAPs, spoke-sdp, and remote sources allowed in a mirror service .....	19
Table 3: Mirroring support for 7210 SAS-M and 7210 SAS-T Access-Uplink mode .....	21
Table 4: Mirroring support for 7210 SAS-M, 7210 SAS-T, 7210 SAS-Mxp, 7210 SAS-X, and 7210 SAS-R6 and 7210 SAS-R12.21	
Table 5: Mirror Source Port Requirements .....	31
<b>OAM and SAA</b>	
Table 6: ETH-CFM Support Matrix for 7210 SAS-M Network Mode .....	111
Table 7: ETH-CFM Support Matrix for 7210 SAS-M Access-Uplink Mode .....	112
Table 8: ETH-CFM Support Matrix for 7210 SAS-T Access-Uplink Mode .....	113
Table 9: ETH-CFM Support Matrix for 7210 SAS-T Network Mode .....	113
Table 10: ETH-CFM Support Matrix for 7210 SAS-X devices .....	114
Table 11: ETH-CFM Support Matrix for 7210 SAS-R6 and 7210 SAS-R12 devices 116	
Table 12: ETH-CFM Support Matrix for 7210 SAS-Mxp devices 118	
Table 13: SAP Encapsulations supported for testhead .....	158
Table 14: Request Packet and Behavior .....	179
Table 15: Request Packet and Behavior .....	186
Table 16: Output fieldstools dump system-resource sap-ingress-qos .....	312
<b>Common CLI Command Descriptions</b>	

# List of Figures

## Mirror Services

Figure 1:	Service Mirroring	.16
Figure 2:	Local Mirroring Example	.22
Figure 3:	Remote Mirroring Example	.23
Figure 4:	Mirror Configuration and Implementation Flow	.24
Figure 5:	Local Mirrored Service Tasks	.33
Figure 6:	Remote Mirrored Service Tasks	.37

## OAM and SAA

Figure 7:	OAM Control Word Format	.82
Figure 8:	VCCV TLV	.83
Figure 9:	VCCV-Ping Application	.84
Figure 10:	MEP and MIP	.120
Figure 11:	MEP, MIP and MD Levels	.121
Figure 12:	CFM Loopback	.122
Figure 13:	CFM Linktrace	.123
Figure 14:	CFM Continuity Check	.125
Figure 15:	CFM CC Failure Scenario	.125
Figure 16:	SLM Example	.132
Figure 17:	Local Fault Propagation	.143
Figure 18:	7210 acting as traffic generator and traffic analyzer	.148

## Common CLI Command Descriptions

## About This Guide

This guide describes service mirroring and Operations, Administration and Management (OAM) and diagnostic tools provided by the 7210 SAS-M, T, X, R6, R12, and Mxp.

On 7210 SAS devices, not all the CLI commands are supported on all the platforms and in all the modes. In many cases, the CLI commands are mentioned explicitly in this document. In other cases, it is implied and easy to know the CLIs that are not supported on a particular platform.

All the variants of 7210 SAS-M, 7210 SAS-T, and 7210 SAS-Mxp can be configured in two modes, that is in network mode and in access-uplink mode. In network mode configuration 7210 SAS-M, 7210 SAS-T, and 7210 SAS-Mxp uses IP/MPLS to provide service transport. In access-uplink mode configuration 7210 SAS-M and 7210 SAS-T uses Ethernet QinQ technology to provide service transport. The mode can be selected by configuring the BOF appropriately. 7210 SAS-Mxp does not support access-uplink mode.

This guide also presents examples to configure and implement various tests.

### Notes:

- This user guide is applicable to all 7210 SAS-M, 7210 SAS-T, 7210 SAS-R6, 7210 SAS-R12, 7210 SAS-X, and 7210 SAS-Mxp platforms, unless specified otherwise.
- In either mode, it is expected that the user will only configure the required CLI parameters appropriate for the mode he intends to use. Unless otherwise noted, most of the configuration is similar in both the network mode and Access uplink mode.
- Only 7210 SAS-M and 7210 SAS-T supports access-uplink mode. 7210 SAS-X, 7210 SAS-R6, and 7210 SAS-R12 does not support access-uplink mode. 7210 SAS-X, 7210 SAS-R6, and 7210 SAS-R12 supports only MPLS uplinks and implicitly operates in network mode. 7210 SAS-Mxp supports only network mode.

- On 7210 SAS devices, not all the CLI commands are supported on all the platforms and in all the modes. In many cases, the CLI commands are mentioned explicitly in this document. In other cases, it is implied and easy to know the CLIs that are not supported on a particular platform.

This document is organized into functional chapters and provides concepts and descriptions of the implementation flow, as well as Command Line Interface (CLI) syntax and command usage.

---

## Audience

This manual is intended for network administrators who are responsible for configuring the 7210 SAS routers. It is assumed that the network administrators have an understanding of networking principles and configurations. Protocols, standards, and services described in this manual include the following:

- CLI concepts
- Subscriber services
- Service mirroring
- Operation, Administration and Maintenance (OAM) operations

## List of Technical Publications

The 7210-SAS-M, T, X, R6, R12, Mxp OS documentation set is composed of the following books:

- 7210-SAS-M, T, X, R6, R12, Mxp OS Basic System Configuration Guide  
This guide describes basic system configurations and operations.
- 7210-SAS-M, T, X, R6, R12, Mxp OS System Management Guide  
This guide describes system security and access configurations as well as event logging and accounting logs.
- 7210-SAS-M, T, X, R6, R12, Mxp OS Interface Configuration Guide  
This guide describes card, Media Dependent Adapter (MDA), LAG, and port provisioning.
- 7210-SAS-M, T, X, R6, R12, Mxp OS Router Configuration Guide  
This guide describes logical IP routing interfaces and associated attributes such as an IP address, port as well as IP and MAC-based filtering.
- 7210-SAS-M, T, X, R6, R12, Mxp OS OS Routing Protocols Guide  
This guide provides an overview of routing concepts and provides configuration examples for protocols and route policies.
- 7210 SAS-M, T, X, R6, R12, Mxp OS MPLS Guide  
This guide describes how to configure Multiprotocol Label Switching (MPLS), Resource Reservation Protocol (RSVP), and Label Distribution Protocol (LDP).
- 7210 SAS-M, T, Mxp OS and 7210-SAS-X, R6, R12 OS Services Guide  
This guide describes how to configure service parameters such as, customer information and user services.
- 7210-SAS-M, T, X, R6, R12, Mxp OS OAM and Diagnostic Guide  
This guide describes how to configure features such as service mirroring and Operations, Administration and Management (OAM) tools.
- 7210 SAS-M, T, Mxp OS and 7210-SAS-X, R6, R12 OS Quality of Service Guide  
This guide describes how to configure Quality of Service (QoS) policy management.

## Technical Support

If you purchased a service agreement for your 7210 SAS and related products from a distributor or authorized reseller, contact the technical support staff for that distributor or reseller for assistance. If you purchased an Alcatel-Lucent service agreement, contact your welcome center.

Web: <http://www.alcatel-lucent.com/portal.html>

# Getting Started

---

## In This Chapter

This book provides process flow information to configure service mirroring and Operations, Administration and Management (OAM) tools.

---

## Alcatel-Lucent 7210 SAS-Series Services Configuration Process

[Table 1](#) lists the tasks necessary to configure mirroring, and perform tools monitoring functions.

This guide is presented in an overall logical configuration flow. Each section describes a software area and provides CLI syntax and command usage to configure parameters for a functional area.

**Table 1: Configuration Process**

Area	Task	Chapter
Diagnostics/ Service verification	Mirroring	<a href="#">Mirror Services on page 15</a>
	OAM	<a href="#">OAM and SAA on page 73</a>
Reference	List of IEEE, IETF, and other proprietary entities.	Standards and Protocols section.



# Mirror Services

---

## In This Chapter

This chapter provides information to configure mirroring.

Topics in this chapter include:

- [Service Mirroring on page 16](#)
- [Mirror Implementation on page 17](#)
  - [Mirror Source and Destinations on page 18](#)
    - [Local and Remote Mirroring on page 20](#)
  - [Mirroring Performance on page 21](#)
  - [Mirroring Configuration on page 22](#)
- [Configuration Process Overview on page 24](#)
- [Configuration Notes on page 25](#)
- [Configuring Service Mirroring with CLI on page 27](#)
- [Basic Mirroring Configuration on page 30](#)
- [Common Configuration Tasks on page 33](#)
- [Service Management Tasks on page 40](#)
- [Mirror Service Command Reference on page 47](#)
- [Configuration Commands on page 51](#)

## Service Mirroring

When troubleshooting complex operational problems, customer packets can be examined as they traverse the network. Alcatel-Lucent's service mirroring provides the capability to mirror customer packets to allow for trouble shooting and offline analysis.

This capability also extends beyond troubleshooting services. Telephone companies have the ability to obtain itemized calling records and wire-taps where legally required by investigating authorities. The process can be very complex and costly to carry out on data networks. Service Mirroring greatly simplifies these tasks, as well as reduces costs through centralization of analysis tools and skilled technicians.

Original packets are forwarded while a copy is sent out the mirrored port to the mirroring (destination) port. Service mirroring allows an operator to see the actual traffic on a customer's service with a sniffer sitting in a central location. In many cases, this reduces the need for a separate, costly overlay sniffer network.

7210 SAS devices configured in access-uplink mode support only local mirroring.

When using local mirroring user has an option to use NULL SAP or a dot1q SAP or a Q1.\* SAP as mirror destination. Use of Dot1q SAP or a Q1.\* SAP as the mirror destination allows the mirrored traffic to share the same uplink as the service traffic (when the uplinks are L2 based).

On some 7210 SAS platforms, when using Dot1q SAP or a Q1.\* SAP or MPLS SDP as the mirror destination user needs to dedicate the resources of a port for use with mirror application (see below for more details).

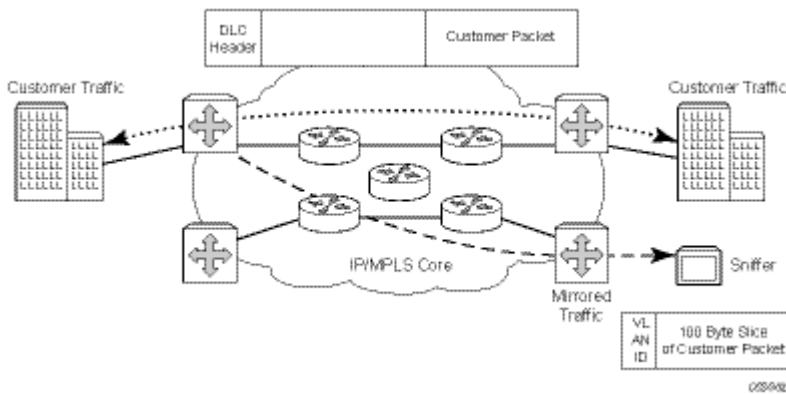

Figure 1: Service Mirroring

## Mirror Implementation

Mirroring can be configured on ingress or egress of certain service entities (For example, SAPs, ports, filter entries) and they are referred to as mirror sources. For more information, see the [“Mirror Source and Destinations on page 18”](#).

Alcatel-Lucent’s implementation of packet mirroring is based on the following assumptions:

- Ingress and egress packets are mirrored as they appear on the wire. This is important for troubleshooting encapsulation and protocol issues.  
When mirroring at ingress, an exact copy of the original ingress packet is sent to the mirror destination while normal forwarding proceeds on the original packet.
- When mirroring is at egress, the system performs normal packet handling on the egress packet, encapsulating it for the destination interface. A copy of the forwarded packet (as seen on the wire) is forwarded to the mirror destination.
  - On 7210 SAS- M, X, Mxp, R6 with IMMV2, R12, the mirror copy of the packet is a copy of the forwarded copy.
  - On 7210 SAS- T, R6 (IMMV1) the mirror copy of the packet is not a exact copy of the forwarded copy in case of port egress mirroring.
  - In 7210 SAS, mirroring at egress takes place before the packet is processed by egress QoS. Hence, there exists a possibility that a packet is dropped by egress QoS mechanisms (because of RED mechanisms and so on) and thus not forwarded, but it is still mirrored.
  - Remote destinations are reached by encapsulating the ingress or egress packet within an SDP, like the traffic for distributed VPN connectivity services. At the remote destination, the tunnel encapsulation is removed and the packet is forwarded out a local SAP.

## Mirror Source and Destinations

Mirror sources and destinations have the following characteristics for 7210 SAS devices operating in network mode.

- Mirror source and mirror destination can be on the same node (local mirroring) or on different nodes (remote mirroring).
- Each mirror destination should terminate on a distinct port carrying only null encapsulation or a Dot1q SAP or a Q1.\* SAP or a MPLS SDP in case of remote mirroring.
- Packets ingressing a port can have a mirror destination separate from packets egressing another or the same port (the ports must be on the same node).
- Multiple mirror destinations are supported (local only) on a single chassis.

Listed below are the mirror sources and destination characteristics for 7210 SAS devices configured in **access-uplink** mode:

- Mirroring source and destination needs to be on the same node (i.e. only local mirroring is supported).
- A mirror destination can terminate on only one port (NULL SAP or dot1q SAP or a Q1.\* SAP).
- Packets ingressing a port can have a mirror destination separate from packets egressing another or the same port.

The following table lists the allowed combinations of SAPs, spoke-sdp and remote sources allowed in a mirror service using different mirror-source-type on 7210 SAS devices configured in network mode:

:

**Table 2: Combinations of SAPs, spoke-sdp, and remote sources allowed in a mirror service**

<b>Mirror-source-type</b>	<b>Mirror sources Allowed</b>	<b>Mirror Destination Allowed</b>
Local	Port Ingress Port Egress SAP ingress ACL ingress	NULL SAP Dot1q SAP QinQ SAP Spoke-SDP
Remote	remote-source	NULL SAP Dot1q SAP QinQ SAP
Both	Port Ingress Port Egress SAP ingress ACL ingress remote-source	NULL SAP Dot1q SAP QinQ SAP

### Local and Remote Mirroring

**NOTE:** This sections describes the local and remote mirroring that are applicable for the platforms on which the mirroring feature is supported. The 7210 SAS devices configured in access-uplink mode supports only local mirroring and the 7210 SAS devices configured in network mode supports both local and remote mirroring.

The 7210 SAS devices allows multiple concurrent mirroring sessions so traffic from more than one ingress mirror source can be mirrored to the same or different mirror destinations. For more information, see the “[Configuration Notes on page 25](#)”.

Remote mirroring uses a service distribution path (SDP) which acts as a logical way of directing traffic from one router to another through a uni-directional (one-way) service tunnel. The SDP terminates at the far-end router which directs packets to the correct destination on that device.

The SDP configuration from the mirrored device to a far-end router requires a return path SDP from the far-end router back to the mirrored router. Each device must have an SDP defined for every remote router to which it provides mirroring services. SDPs must be created first, before services can be configured.

## Mirroring Performance

Replication of mirrored packets can, typically, affect performance and should be used carefully.

The following tables mentions about the mirroring that can be performed based on the following criteria (that is, mirror sources):

**Table 3: Mirroring support for 7210 SAS-M and 7210 SAS-T Access-Uplink mode**

Mirroring	7210 SAS-M	7210 SAS-T
Port (ingress and egress)	Supported	Supported
SAP (ingress only)	Supported	Supported
MAC filter (ingress only)	Supported	Supported
IP filter (ingress only)	Supported	Supported

**Table 4: Mirroring support for 7210 SAS-M, 7210 SAS-T, 7210 SAS-Mxp, 7210 SAS-X, and 7210 SAS-R6 and 7210 SAS-R12.**

Mirroring	7210 SAS-M	7210 SAS-T	7210 SAS-Mxp	7210 SAS-X	7210 SAS-R6 and R12
Port (ingress and egress)	Supported	Supported	Supported	Supported	Supported
SAP (ingress only)	Supported	Supported	Supported	Supported	Supported
MAC filter (ingress only)	Supported	Supported	Supported	Supported	Supported
IP filter (ingress only)	Supported	Supported	Supported	Supported	Supported

## Mirroring Configuration

Configuring mirroring is similar to creating a uni-direction service. Mirroring requires the configuration of:

- Mirror source — The traffic on a specific point(s) to mirror.
- Mirror destination — The location to send the mirrored traffic, where the sniffer will be located.

Figure 2 depicts a local mirror service configured on ALA-A.

- Port 1/1/2 is specified as the source. Mirrored traffic ingressing and egressing this port will be sent to port 1/1/3.
- SAP 1/1/3 is specified as the destination. The sniffer is physically connected to this port. Mirrored traffic ingressing and egressing port 1/1/2 is sent here. SAP, encapsulation requirements, and mirror classification parameters are configured.

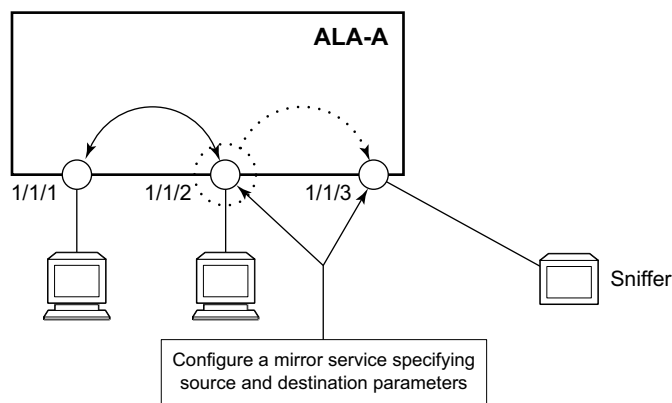

**Figure 2: Local Mirroring Example**

Figure 3 depicts a remote mirror service configured as ALA B as the mirror source and ALA A as the mirror destination. Mirrored traffic ingressing and egressing port 5/2/1 (the source) on ALA B is handled the following ways:

- Port 5/2/1 is specified as the mirror source port. Parameters are defined to select specific traffic ingressing and egressing this port.

Destination parameters are defined to specify where the mirrored traffic is sent. In this case, mirrored traffic sent to a SAP configured as part of the mirror service on port 3/1/3 on ALA A (the mirror destination).

ALA A decodes the service ID and sends the traffic out of port 3/1/3.

The sniffer is physically connected to this port (3/1/3). SAP, encapsulation requirements,

packet slicing, and mirror classification parameters are configured in the destination parameters.

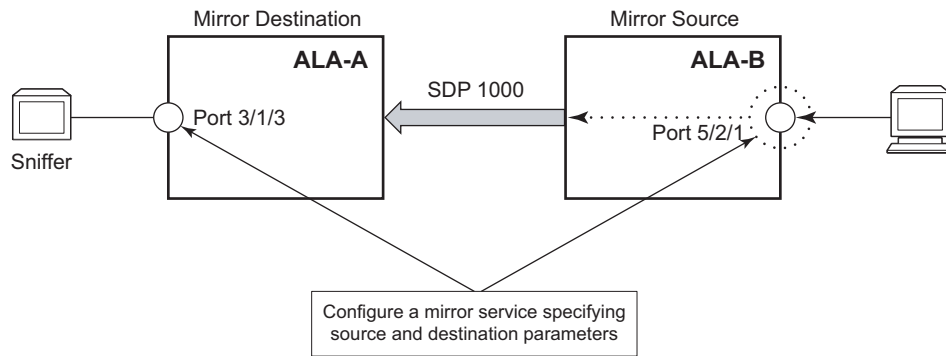

OSSG027

**Figure 3: Remote Mirroring Example**

# Configuration Process Overview

Figure 4 displays the process to provision basic mirroring parameters.

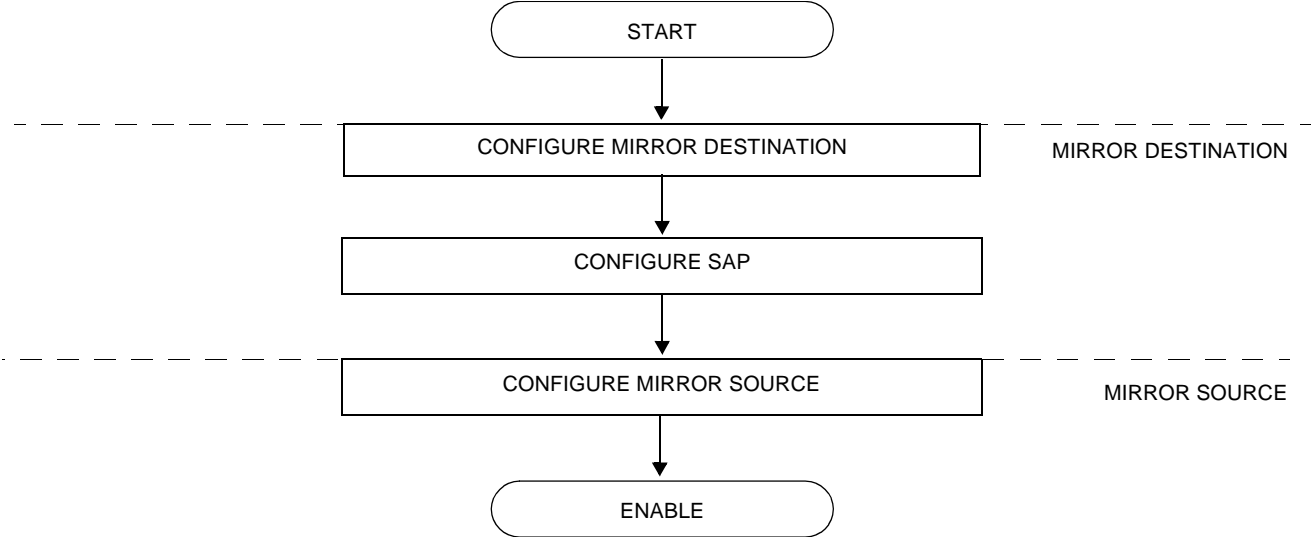

Figure 4: Mirror Configuration and Implementation Flow

## Configuration Notes

This section describes mirroring configuration caveats.

- Multiple mirroring service IDs (mirror destinations) may be created within a single system.
- A mirrored source can only have one destination.
- On 7210 SAS-R6, 7210 SAS-R12, 7210 SAS-M, 7210 SAS-T, 7210 SAS-X, and 7210 SAS-Mxp before using a Dot1q SAP or Q1.\* SAP as a mirror destination, the user must configure a port for use with this feature using the command `config> system> loopback-no-svc-port mirror`. The user has an option to use either one of the available virtual internal port resources or a front panel port. The virtual internal port resources available can be determined using the command `show system internal-loopback-ports detail`. No services can be configured on this port. More details of both the commands can be found in the 7210 SAS Interfaces Configuration Guide.
- On 7210 SAS-R6, 7210 SAS-R12, 7210 SAS-M, 7210 SAS-X, 7210 SAS-T, and 7210 SAS-Mxp before using a MPLS SDP as a mirror destination, the user must configure a port for use with this feature using the command `config> system> loopback-no-svc-port mirror`. No services can be configured on this port. The user has an option to use either one of the available virtual internal port resources or a front panel port. The virtual internal port resources available can be determined using the command `show system internal-loopback-ports detail`. More details of both the commands can be found in the 7210 SAS Interfaces Configuration Guide.
- Spoke SDP is supported only on local mirror service type. Please refer to the [Combinations of SAPs, spoke-sdp, and remote sources allowed in a mirror service on page 19](#) above for more information.
- Remote source mirror type service accepts only MPLS labeled traffic from remote sources.
- The destination mirroring service IDs and service parameters are persistent between router (re)boots and are included in the configuration saves.

Mirror source criteria configuration (defined in `debug>mirror>mirror-source`) is not preserved in a configuration save (admin save). Debug mirror source configuration can be saved using `admin>debug-save`.

- Physical layer problems such as collisions, jabbers, etc., are not mirrored. Typically, only complete packets are mirrored.
- Starting and shutting down mirroring:

### Mirror destinations:

- The default state for a mirror destination service ID is shutdown. You must issue a **no shutdown** command to enable the feature.
- When a mirror destination service ID is shutdown, mirrored packets associated with the service ID are not accepted from its mirror source. The associated mirror source is put into an operationally down mode. Mirrored packets are not transmitted out the SAP. Each mirrored packet is silently discarded.
- Issuing the `shutdown` command causes the mirror destination service or its mirror source to be put into an administratively down state. Mirror destination service IDs must be shut down first in order to delete a service ID, or SAP association from the system.

### Mirror sources:

- The default state for a mirror source for a given mirror-dest service ID is `no shutdown`. Enter a `shutdown` command to deactivate (disable) mirroring from that mirror-source.
- Mirror sources do not need to be shutdown to remove them from the system. When a mirror source is shutdown, mirroring is terminated for all sources defined locally for the mirror destination service ID.

## Configuring Service Mirroring with CLI

This section provides information about service mirroring

Topics in this section include:

- [Mirror Configuration Overview on page 28](#)
- [Basic Mirroring Configuration on page 30](#)
  - [Mirror Classification Rules on page 31](#)
- [Common Configuration Tasks on page 33](#)
  - [Configuring a Local Mirror Service on page 34](#)
  - [Configuring a Remote Mirror Service on page 36](#)
- [Service Management Tasks on page 40](#)
  - [Modifying a Local Mirrored Service on page 41](#)
  - [Deleting a Local Mirrored Service on page 42](#)
  - [Modifying a Remote Mirrored Service on page 43](#)
  - [Deleting a Remote Mirrored Service on page 45](#)

## Mirror Configuration Overview

7210 SAS M mirroring can be organized in the following logical entities:

- The mirror source is defined as the location from where the traffic should be mirrored. A mirror source could be ingress of service entity or egress of a service entity. The list of mirror sources supported on a given platform is listed above [Mirror Source Port Requirements on page 31](#)
  - A SAP is defined in local mirror services as the mirror destination to where the mirrored packets are sent.
- 

### Defining Mirrored Traffic

In some scenarios, or when multiple services are configured on the same port, specifying the port does not provide sufficient resolution to separate traffic. In Alcatel-Lucent's implementation of mirroring, multiple source mirroring parameters can be specified to further identify traffic.

Mirroring of packets matching specific filter entries in an IP or MAC filter can be applied to refine what traffic is mirrored to flows of traffic within a service. The IP criteria can be combinations of:

- Source IP address/mask
- Destination IP address/mask
- IP Protocol value
- Source port value (for example, UDP or TCP port)
- Destination port value (for example, UDP or TCP port)
- DiffServ Code Point (DSCP) value
- ICMP code
- ICMP type
- IP fragments
- TCP ACK set/reset
- TCP SYN set/reset

The MAC criteria can be combinations of:

- IEEE 802.1p value/mask
- Source MAC address/mask
- Destination MAC address/mask
- Ethernet Type II Ethernet type value

---

**NOTE:** The list of packet fields that are available to match packets in IP and MAC ACLs for different platforms is different. For more information on the lists of packet fields available on different platforms, see the “7210 SAS Router Configuration User Guide”.

---

## Basic Mirroring Configuration

Destination mirroring parameters must include at least:

- A mirror destination ID (same as the mirror source service ID).
- A mirror destination SAP.

Mirror source parameters must include at least:

- A mirror service ID (same as the mirror destination service ID).
- At least one source type (port, SAP, IP filter or MAC filter) specified.

The following example displays a sample configuration of a local mirrored service (ALA-A).

```
*A:ALA-A>config>mirror# info
-----
mirror-dest 103 create
  sap 1/1/1 create
  exit
  no shutdown
  exit
-----
*A:ALA-A>config>mirror#
```

The following displays the mirror source configuration:

```
*A:ALA-A>debug>mirror-source# show debug mirror
debug
  mirror-source 103
    port 1/1/24 egress ingress
    no shutdown
  exit
exit
*A:ALA-A>debug>mirror-source# exit
```

## Mirror Classification Rules

Alcatel-Lucent's implementation of mirroring can be performed by configuring parameters to select network traffic according to any of the following entities:

- [Port](#)
- [SAP](#)
- [MAC filter](#)
- [IP filter](#)

### Port

The `port` command associates a port to a mirror source. The port is identified by the port ID. The defined port can be Ethernet or a Link Aggregation Group (LAG) ID. When a LAG ID is given as the port ID, mirroring is enabled on all ports making up the LAG.

Mirror sources can be ports in either access or network mode. Port mirroring is supported in the following combinations:

**Table 5: Mirror Source Port Requirements**

Port Type	Port Mode	Port Encap Type
faste/gige/10gige	access	null, dot1q and QinQ
faste/gige/10gige	access uplink	qinq
faste/gige/10gige	network	null/dot1q
faste/gige/10gige	hybrid	null/dot1q/qinq

**CLI Syntax:** `debug>mirror-source# port {port-id|lag lag-id} {[egress][ingress]}`

**Example:** `*A:ALA-A>debug>mirror-source# port 1/1/2 ingress egress`

### SAP

More than one SAP can be associated within a single mirror-source. Each SAP has its own ingress parameter keyword to define which packets are mirrored to the mirror-dest service ID. A SAP that is defined within a mirror destination cannot be used in a mirror source.

**CLI Syntax:** `debug>mirror-source# sap sap-id {[ingress]}`

**Example:** `*A:ALA-A>debug>mirror-source# sap 1/1/4:100 ingress`

## Basic Mirroring Configuration

1

### MAC filter

MAC filters are configured in the **config>filter>mac-filter** context. The **mac-filter** command causes all the packets matching the explicitly defined list of entry IDs to be mirrored to the mirror destination specified by the service-id of the mirror source.

**CLI Syntax:** `debug>mirror-source# mac-filter mac-filter-id entry entry-id [entry-id ...]`

**Example:** `*A:ALA-2>debug>mirror-source# mac-filter 12 entry 15 20 25`

---

### IP filter

IP filters are configured in the **config>filter>ip-filter** context. The **ip-filter** command causes all the packets matching the explicitly defined list of entry IDs to be mirrored to the mirror destination specified by the service-id of the mirror source.

Ingress mirrored packets are mirrored to the mirror destination prior to any ingress packet modifications.

**CLI Syntax:** `debug>mirror-source# ip-filter ip-filter-id entry entry-id [entry-id ...]`

**Example:** `*A:ALA-A>debug>mirror-source# ip-filter 1 entry 20`

**NOTE:** An IP filter cannot be applied to a mirror destination SAP.

## Common Configuration Tasks

This section provides a brief overview of the tasks that must be performed to configure local mirror services and provides CLI command syntax. Note that the local mirror source and mirror destination components must be configured under the same service ID context.

Each local mirrored service (Figure 5) (within the same router) requires the following configurations:

1. Specify mirror destination (SAP).
2. Specify mirror source (port, SAP, IP filter, MAC filter).

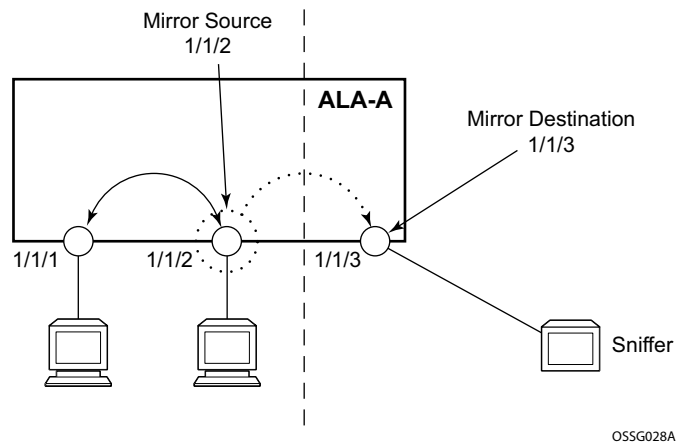

Figure 5: Local Mirrored Service Tasks

## Configuring a Local Mirror Service

To configure a local mirror service, the source and destinations must be located on the same router. Note that local mirror source and mirror destination components must be configured under the same service ID context.

The **mirror-source** commands are used as traffic selection criteria to identify traffic to be mirrored at the source. Each of these criteria are independent. For example, use the **debug>mirror-source>port** *{port-id | lag lag-id}* **{[egress] [ingress]}** command and **debug>mirror-source ip-filter** *ip-filter-id* **entry** *entry-id* *[entry-id...]* command to capture (mirror) traffic that matches a specific IP filter entry and traffic ingressing and egressing a specific port. A filter must be applied to the SAP or interface if only specific packets are to be mirrored.

Use the CLI syntax to configure one or more mirror source parameters:

The **mirror-dest** commands are used to specify where the mirrored traffic is to be sent. Use the following CLI syntax to configure mirror destination parameters:

**CLI Syntax:** `config>mirror mirror-dest service-id [type {ether}] [create]  
description string  
sap sap-id [create]  
no shutdown`

**CLI Syntax:** `debug# mirror-source service-id  
ip-filter ip-filter-id entry entry-id [entry-id ...]  
ipv6-filter ip-filter-id entry entry-id [entry-id ...]  
mac-filter mac-filter-id entry entry-id [entry-id ...]  
port {port-id|lag lag-id} {[egress][ingress]}  
sap sap-id {[ingress]}  
no shutdown`

The following output displays an example of a local mirrored service using a NULL SAP. On ALA-A, mirror service 103 is mirroring traffic matching IP filter 2, entry 1 as well as egress and ingress traffic on port 1/1/23 and sending the mirrored packets to SAP 1/1/24

```
*A:ALA-A>config>mirror# info
-----
mirror-dest 103 create
  sap 1/1/24 create
  exit
  no shutdown
exit
-----
*A:ALA-A>config>mirror#
```

The following output displays an example of local mirrored service using a dot1q SAP. User needs to configure a front-panel port for use with the mirroring application when the mirror destination is a Dot1q SAP or a Q1.\* SAP, as shown below.

```
*A:ALA-A>config>system>
-----
      loopback-no-svc-port mirror 1/1/14
-----

*A:ALA-A>config>mirror# info
-----
      mirror-dest 103 create
          sap 1/1/10:100 create
          exit
          no shutdown
      exit
-----

*A:ALA-A>config>mirror#
```

The following displays the debug mirroring information:

```
*A:ALA-A>debug>mirror-source# show debug mirror
debug
      mirror-source 103
          no shutdown
          port 1/1/23 ingress
          ip-filter 2 entry 1
      exit
exit
*A:ALA-A>debug>mirror-source# exit
```

## Configuring a Remote Mirror Service

The source and destination are configured on different routers for remote mirroring. Note that *mirror source* and *mirror destination* parameters must be configured under the same service ID context.

**NOTE:** Remote Mirroring using MPLS SDP is supported only on 7210 SAS devices configured in Network Mode. It is not supported on 7210 SAS devices configured in access-uplink mode.

The **mirror-source** commands are used as traffic selection criteria to identify traffic to be mirrored at the source. For example, use the **port** *port-id* [*lag-id*] {[**egress**] [**ingress**]} and **mac-filter** *mac-filter-id* **entry** *entry-id* [*entry-id* ...] commands.

Use the CLI syntax to configure one or more mirror source parameters:

```
CLI Syntax: debug> mirror-source service-id
    ip-filter ip-filter-id entry entry-id [entry-id ...]
    ipv6-filter ip-filter-id entry entry-id [entry-id ...]
    mac-filter mac-filter-id entry entry-id [entry-id ...]
    port {port-id|lag lag-id} {[egress][ingress]}
    sap sap-id {[ingress]}
    no shutdown
```

The **mirror-dest** commands are used to specify where the mirrored traffic is to be sent, the forwarding class, and the size of the packet. Use the following CLI syntax to configure mirror destination parameters:

```
CLI Syntax: config>mirror#
```

```
mirror-dest service-id

    [create] [type <mirror-type>] [mirror-source-type <mirror-
source-type>]
    description string
    fc fc-name [profile <profile>]
    remote-source
        far-end <ip-address> [vc-id <vc-id>] [ing-svc-label <i
ngress-vc-label>|tldp]
    sap sap-id create
    no shutdown
```

The following [Table 6, Remote Mirrored Service Tasks, on page 37](#) displays the mirror destination, which is on ALA-A, configuration for mirror service 1216. This configuration specifies that the mirrored traffic coming from the mirror source (10.10.0.91) is to be directed to SAP /1/58 and states that the service only accepts traffic from far end 10.10.0.92 (ALA-B) with an ingress service label of 5678. When a forwarding class is specified, then all mirrored packets

transmitted to the destination SAP or SDP override the default (be) forwarding class. The slice size limits the size of the stream of packet through 7210 SAS and the core network.

**Figure 6: Remote Mirrored Service Tasks**

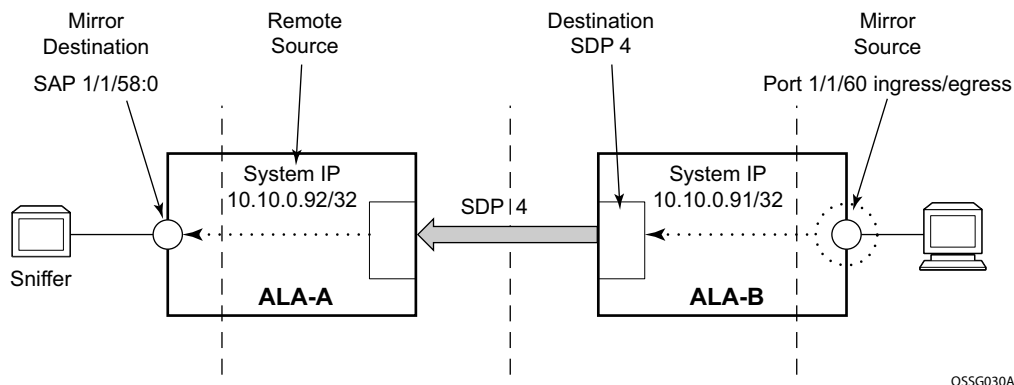

The following example displays the CLI output showing the configuration of remote mirrored service 1216. The traffic ingressing and egressing port 1/1/60 on 10.10.0.92 (ALA-B) will be mirrored to the destination SAP 1/1/58:0 on ALA-A.

The following example displayed is the remote mirror destination configuring the front panel port with mirroring application:

```
*A:7210SAS>config>mirror# info
-----
mirror-dest 23 mirror-source-type remote create
description "Added by createMirrorDestination 23"
fc be
remote-source
  far-end 2.2.2.2 ing-svc-label 14000
exit
sap 1/1/4 create
exit
no shutdown
exit
mirror-dest 1000 create
fc be
spoke-sdp 200:1000 create
egress
  vc-label 15000
exit
no shutdown
exit
no shutdown
exit
-----
*A:7210SAS>config>mirror# /show system internal-loopback-ports
=====
Internal Loopback Port Status
```

## Common Configuration Tasks

```
=====
Port          Loopback      Application      Service
Id            Type          Application      Enabled
-----
1/1/9         Physical      Dot1q-Mirror     No
=====
```

The following example displayed is the mirror destination configuration for mirror service 1216 on ALA-A.

```
*A:ALA-A>config>mirror# info
-----
      mirror-dest 1000 type ether mirror-source-type remote create
      description "Receiving mirror traffic from .91"
      remote-source
        far-end 2.2.2.2 tldp
      exit
      sap 1/1/21:21 create
        egress
          qos 1
        exit
      exit
      no shutdown
    exit
-----
*A:ALA-A>config>mirror#
```

The following example displays the remote mirror destination configured on ALA-B:

```
*A:ALA-B>config>mirror# info
-----
mirror-dest 2000 type ether mirror-source-type local create
  no description
  no service-name
  fc be
  no remote-source
  spoke-sdp 200:2000 create
    egress
      no vc-label
    exit
    no shutdown
  exit
  no shutdown
exit
-----
*A:ALA-B>config>mirror#
```

The following example displays the mirror source configuration for ALA-B:

```
*A:ALA-B# show debug mirror
debug
  mirror-source 1000
```

```
        no shutdown
    exit
    mirror-source 2000
        no shutdown
    exit
exit
*A:ALA-B#
```

The following example displays the SDP configuration from ALA-A to ALA-B (SDP 2) and the SDP configuration from ALA-B to ALA-A (SDP 4).

```
*A:ALA-A>config>service>sdp# info
-----
        description "MPLS-10.10.0.91"
        far-end 10.10.0.01
        signalling tldp
        no shutdown
-----
*A:ALA-A>config>service>sdp#
```

```
*A:ALA-B>config>service>sdp# info
-----
        description "MPLS-10.10.20.92"
        far-end 10.10.10.103
        signalling tldp
        no shutdown
-----
*A:ALA-B>config>service>sdp#
```

## Service Management Tasks

This section discusses the following service management tasks:

- [Modifying a Local Mirrored Service on page 41](#)
- [Deleting a Local Mirrored Service on page 42](#)
- [Modifying a Remote Mirrored Service on page 43](#)
- [Deleting a Remote Mirrored Service on page 45](#)

Use the following command syntax to modify an existing mirrored service:

**CLI Syntax:** config>mirror#

```
mirror-dest service-id [type {ether}]  
description description-string  
no description  
sap sap-id  
no sap  
[no] shutdown
```

**CLI Syntax:** debug

```
[no] mirror-source service-id  
ip-filter ip-filter-id entry entry-id [entry-id...]  
no ip-filter ip-filter-id  
no ip-filter entry entry-id [entry-id...]  
ipv6-filter ip-filter-id entry entry-id [entry-id...]  
no ipv6-filter ip-filter-id  
no ipv6-filter entry entry-id [entry-id...]  
mac-filter mac-filter-id entry entry-id [entry-id...]  
no mac-filter mac-filter-id  
no mac-filter mac-filter-id entry entry-id [entry-id...]  
[no] port {port-id|lag lag-id} {[egress][ingress]}  
[no] sap sap-id {[ingress]}  
[no] shutdown
```

## Modifying a Local Mirrored Service

Existing mirroring parameters can be modified in the CLI. The changes are applied immediately. The service must be shut down if changes to the SAP are made.

The following example displays commands to modify parameters for a basic local mirroring service.

```
Example: config>mirror# mirror-dest 103
config>mirror>mirror-dest# shutdown
config>mirror>mirror-dest# no sap
config>mirror>mirror-dest# sap 1/1/5 create
config>mirror>mirror-dest>sap$ exit
config>mirror>mirror-dest# no shutdown
debug# mirror-source 103
debug>mirror-source# no port 1/1/23
debug>mirror-source# port 1/1/7 ingress egress
```

The following displays the local mirrored service modifications:

```
*A:ALA-A>config>mirror# info
-----
mirror-dest 103 create
          no shutdown
          sap 1/1/5 create
          exit

*A:ALA-A>debug>mirror-source# show debug mirror
debug
  mirror-source 103
    no shutdown
    port 1/1/7 egress ingress
  exit
*A:ALA-A>debug>mirror-source#
```

## Deleting a Local Mirrored Service

Existing mirroring parameters can be deleted in the CLI. A shutdown must be issued on a service level in order to delete the service. It is not necessary to shut down or remove SAP or port references to delete a local mirrored service.

The following example displays commands to delete a local mirrored service.

```
Example:ALA-A>config>mirror# mirror-dest 103
config>mirror>mirror-dest# shutdown
config>mirror>mirror-dest# exit
config>mirror# no mirror-dest 103
config>mirror# exit
```

## Modifying a Remote Mirrored Service

Existing mirroring parameters can be modified in the CLI. The changes are applied immediately. The service must be shut down if changes to the SAP are made.

In the following example, the mirror destination is changed from 10.10.10.2 (ALA-B) to 10.10.10.3 (SR3). Note that the mirror-dest service ID on ALA-B must be shut down first before it can be deleted.

The following example displays commands to modify parameters for a remote mirrored service.

```
Example:*A:ALA-A>config>mirror# mirror-dest 104
config>mirror>mirror-dest# remote-source
config>mirror>mirror-dest>remote-source# no far-end 10.10.10.2
remote-source# far-end 10.10.10.3 ing-svc-label 3500
```

```
*A:ALA-B>config>mirror# mirror-dest 104
config>mirror>mirror-dest# shutdown
config>mirror>mirror-dest# exit
config>mirror# no mirror-dest 104
```

```
SR3>config>mirror# mirror-dest 104 create
config>mirror>mirror-dest# sdp 4 egr-svc-label 3500
config>mirror>mirror-dest# no shutdown
config>mirror>mirror-dest# exit all
```

```
SR3># debug
debug# mirror-source 104
debug>mirror-source# port 551/1/2 ingress egress
debug>mirror-source# no shutdown
```

```
*A:ALA-A>config>mirror# info
```

```
-----
mirror-dest 104 create
  remote-source
    far-end 2.2.2.2 tldp
  exit
  sap 1/1/21:21 create
    egress
      qos 1
    exit
  exit
  no shutdown
exit
```

```
A:SR3>config>mirror# info
```

```
-----
mirror-dest 104 create
spoke-sdp 200:2000 create
  no shutdown
exit
```

## Service Management Tasks

```
-----  
A:SR3>config>mirror#  
  
A:SR3# show debug mirror  
debug  
  mirror-source 104  
  no shutdown
```

## Deleting a Remote Mirrored Service

Existing mirroring parameters can be deleted in the CLI. A shut down must be issued on a service level to delete the service. It is not necessary to shut down or remove SAP, or far-end references to delete a remote mirrored service.

To delete a mirror service, the spoke-SDP service has to be deleted from the service. Mirror destinations must be shut down first before they are deleted.

```

Example:*A:ALA-A>config>mirror# mirror-dest 105
config>mirror>mirror-dest# shutdown
config>mirror>mirror-dest# exit
config>mirror# no mirror-dest 105
config>mirror# exit

*A:ALA-B>config>mirror# mirror-dest 105
config>mirror>mirror-dest# shutdown
config>mirror>mirror-dest# exit
config>mirror# no mirror-dest 105
config>mirror# exit

```

The mirror-destination service ID 105 was removed from the configuration on ALA-A and ALA-B, thus, does not appear in the `info` command output.

```

*A:ALA-A>config>mirror# info
-----
-----
*A:ALA-A>config>mirror# exit

*A:ALA-B>config>mirror# info
-----
-----
*A:ALA-B>config>mirror# exit

```

Since the mirror destination was removed from the configuration on ALA-B, the port information was automatically removed from the `debug mirror-source` configuration.

```

*A:ALA-B# show debug mirror
debug
exit
*A:ALA-B#

```



---

## Mirror Service Command Reference

---

- [Mirror Configuration Commands for 7210 SAS-M and 7210 SAS-T in Network mode on page 47](#)
- [Mirror Configuration Commands for 7210 SAS devices configured in Access-uplink mode on page 48](#)
- [Mirror Configuration Commands for 7210 SAS-X, 7210 SAS-Mxp, 7210 SAS-R6, and 7210 SAS-R12 on page 48](#)
- [Show Commands on page 49](#)
- [Debug Commands on page 49](#)

### Mirror Configuration Commands for 7210 SAS-M and 7210 SAS-T in Network mode

```

config
  — mirror
    — mirror-dest service-id [type mirror-type] [mirror-source-type mirror-source-type]
      [create]
    — no mirror-dest service-id
      — description description-string
      — no description
      — [no] fc [fc-name] profile { profile }
      — no remote-source
      — remote-source
        — far-end ip-address [vc-id vc-id] [ing-svc-label ingress-vc-label] tldp]
        — no far-end ip-address
      — sap sap-id [create]
      — no sap
      — service-name service-name
      — [no] service-name
      — [no] shutdown
      — no spoke-sdp sdp-id:vc-id
      — spoke-sdp sdp-id:vc-id [create]
        — egress
          — no vc-label [egress-vc-label]
          — vc-label egress-vc-label
          — no shutdown
          — shutdown

```

## Mirror Configuration Commands for 7210 SAS devices configured in Access-uplink mode

```
config
— mirror
— mirror-dest service-id [type mirror-type] [create]
— no mirror-dest service-id
— description description-string
— no description
— [no] fc [fc-name] profile { profile }
— sap sap-id [create]
— no sap
— service-name service-name
— [no]service-name
— [no] shutdown
```

## Mirror Configuration Commands for 7210 SAS-X, 7210 SAS-Mxp, 7210 SAS-R6, and 7210 SAS-R12

```
config
— mirror
— mirror-dest service-id [type encap-type][mirror-source-type mirror-source-type] [create]
— no mirror-dest service-id
— description description-string
— no description
— [no] fc [fc-name]
— no remote-source
— remote-source
— far-end ip-address [vc-id vc-id] [ing-svc-label ingress-vc-label] tl dp]
— no far-end ip-address
— sap sap-id [create]
— no sap
— [no] egress
— [no] qos policy-id
— service-name service-name
— [no]service-name
— [no] shutdown
— no spoke-sdp sdp-id:vc-id
— spoke-sdp sdp-id:vc-id [create]
— egress
— no vc-label [egress-vc-label]
— vc-label egress-vc-label
— no shutdown
— shutdown
```

## Show Commands

```
show
  — debug [application]
  — mirror mirror-dest [service-id]
  — service
     — service-using mirror
```

## Debug Commands

```
debug
  — [no] mirror-source service-id
     — [no] ip-filter ip-filter-id [entry entry-id]
     — [no] ipv6-filter ipv6-filter-id [entry entry-id]
     — [no] mac-filter mac-filter-id [entry entry-id...]
     — [no] port {port-id | lag lag-id} [egress] [ingress]
     — [no] sap sap-id {[ingress] [egress]}
     — [no] shutdown
```



---

## Configuration Commands

---

### Generic Commands

#### description

**Syntax** **description** *description-string*  
**no description**

**Context** config>mirror>mirror-dest

**Description** This command creates a text description stored in the configuration file for a configuration context to help the administrator identify the content of the file.

The **no** form of the command removes the description string.

**Default** There is no default description associated with the configuration context.

**Parameters** *description-string* — The description character string. Allowed values are any string up to 80 characters long composed of printable, 7-bit ASCII characters. If the string contains special characters (#, \$, spaces, etc.), the entire string must be enclosed within double quotes.

#### shutdown

**Syntax** [**no**] **shutdown**

**Context** config>mirror>mirror-dest  
 config>mirror>mirror-dest>spoke-sdp>egress  
 debug>mirror-source

**Description** The **shutdown** command administratively disables an entity. When disabled, an entity does not change, reset, or remove any configuration settings or statistics. Many entities must be explicitly enabled using the **no shutdown** command.

The **shutdown** command administratively disables an entity. The operational state of the entity is disabled as well as the operational state of any entities contained within. Many objects must be shut down before they may be deleted.

Unlike other commands and parameters where the default state is not indicated in the configuration file, **shutdown** and **no shutdown** are always indicated in system generated configuration files.

The **no** form of the command puts an entity into the administratively enabled state.

**Default** See Special Cases below.

**Special Cases** **Mirror Destination** — When a mirror destination service ID is shutdown, mirrored packets associated with the service ID are not accepted from the mirror source device. The associated mirror source is put into

## Configuration Commands

an operationally down mode. Mirrored packets are not transmitted out of the SAP. Each mirrored packet is silently discarded. If the mirror destination is a SAP, the SAP's discard counters are increased.

The **shutdown** command places the mirror destination service or mirror source into an administratively down state. The **mirror-dest** service ID must be shut down in order to delete the service ID, SAP association from the system.

The default state for a mirror destination service ID is **shutdown**. A **no shutdown** command is required to enable the service.

**Mirror Source** — Mirror sources do not need to be shutdown in order to remove them from the system.

When a mirror source is **shutdown**, mirroring is terminated for all sources defined locally for the **mirror-dest** service ID.

The default state for a mirror source for a given **mirror-dest** service ID is **no shutdown**. A **shutdown** command is required to disable mirroring from that mirror-source.

---

## Mirror Destination Configuration Commands

### mirror-dest

**Syntax** `mirror-dest service-id [type encap-type] [mirror-source-type mirror-source-type][create]`  
`no mirror-dest`

**Context** config>mirror

**Description** **Note: The “mirror-source-type” parameter is not applicable for 7210 SAS-M in Access-uplink mode.**

This command creates a context to set up a service that is intended for packet mirroring. It is configured as a service to allow mirrored packets to be directed locally (within the same device), over the core of the network and have a far end device decode the mirror encapsulation.

The **mirror-dest** service is comprised of destination parameters that define where the mirrored packets are to be sent. It also specifies whether the defined *service-id* will receive mirrored packets from far end devices over the network core.

The **mirror-dest** service IDs are persistent between boots of the router and are included in the configuration backups. The local sources of mirrored packets for the service ID are defined within the **debug mirror mirror-source** command that references the same *service-id*.

The **mirror-dest** command is used to create or edit a service ID for mirroring purposes. If the *service-id* does not exist within the context of all defined services, the **mirror-dest** service is created and the context of the CLI is changed to that service ID. If the *service-id* exists within the context of defined **mirror-dest** services, the CLI context is changed for editing parameters on that service ID. If the *service-id* exists within the context of another service type, an error message is returned and CLI context is not changed from the current context.

The **no** form of the command removes a mirror destination from the system. The **mirror-source** associations with the **mirror-dest** *service-id* do not need to be removed or shutdown first. The **mirror-dest** *service-id* must be shutdown before the service ID can be removed. When the service ID is removed, all **mirror-source** commands that have the service ID defined will also be removed from the system.

**Default** No packet mirroring services are defined.

**Parameters** *service-id* — The service id identifies the service in the service domain. This ID is unique to this service and cannot be used by any other service, regardless of service type. The same service ID must be configured on every device that this particular service is defined on.

If a particular service ID already exists for a service, then the same value cannot be used to create a mirror destination service ID with the same value.

For example:

If an Epipe service-ID **11** exists, then a mirror destination service-ID **11** cannot be created. If a VPLS service-ID **12** exists, then a mirror destination service-ID **12** cannot be created.

If an IES service-ID **13** exists, then a mirror destination service-ID **13** cannot be created.

**Values** *service-id:* 1 — 2147483647

## Configuration Commands

**type** *encap-type* — The type describes the encapsulation supported by the mirror service.

**Values** ether

*mirror-source-type* — This allows scaling of mirror services that can be used only with remote mirror sources, while limiting the mirror services that can be used by local mirror sources or by both local and remote mirror sources. For more information, see Table 2, Combinations of SAPs, spoke-sdp, and remote sources allowed in a mirror service, on page 19.

**Values** local | remote | both

**local** — indicates that the mirror service can only be used by local mirror sources.

**remote** — indicates that the mirror service can only be used by remote mirror sources.

**both** — indicates that the mirror service can be used by both local and remote mirror sources.

**Default** local

## fc

**Syntax** **fc fc-name**  
**no fc**

**Context** config>mirror>mirror-dest

**Description** This command specifies a forwarding class for all mirrored copy of the packets transmitted to the destination SAP overriding the default (be) forwarding class. All packets are sent with the same class of service to minimize out of sequence issues. The mirrored copy of the packet does not inherit the forwarding class of the original packet.

When the destination is on a SAP, it pulls buffers from the queue associated with the fc-name and the shaping and scheduling treatment given to the packet is as per the user configuration for that queue.

FC can be assigned only when the mirror source is local. When the mirror source is remote, the network QoS ingress policies that are applied to all the traffic received on the network port and network IP interface are also applied to mirror traffic.

On 7210 SAS-M and 7210 SAS-T all SAPs configured on a port use the port-based egress queues. If the mirror destination SAP (that is, dot1q SAP or a Q1.\* SAP) is configured to share an uplink with service traffic, mirrored copy of the traffic sent out of the Dot1q or Q1.\* SAP will share the port-based egress queues with the other service traffic. User is provided an option to assign the profile mirrored copy to the packet, so that during congestion mirrored copy of the packets marked as out-of-profile is dropped before in-profile service traffic (and possibly in-profile mirrored traffic, if user has configured mirrored traffic to be in-profile). The profile is used to determine the slope policy to use for the packet and determines the packet's drop precedence. Additionally, if marking is enabled, it determines the marking value to be used in the packet header.

On 7210 SAS-X and 7210 SAS-Mxp, SAP based egress QoS policy can be used on the mirrored destination SAP, allowing users to control the bandwidth allocated for mirrored traffic. On 7210 SAS-R6 and 7210 SAS-R12, SAP based egress queue QoS policy is used when the "port-based egress queuing is disabled" on

the mirrored destination SAP, allowing users to control the amount of bandwidth allocated for mirrored traffic. If port-based queuing is enabled, all SAPs configured on a port use the port-based egress queues.

The no form of the command returns the mirror-dest service ID forwarding class to the default forwarding class.

**Default** The best effort (be) forwarding class is associated with the mirror-dest service ID and profile is out.

**Parameters** *fc-name* — The name of the forwarding class with which to associate mirrored service traffic. The forwarding class name must already be defined within the system. If the *fc-name* does not exist, an error will be returned and the *fc* command will have no effect. If the *fc-name* does exist, the forwarding class associated with *fc-name* will override the default forwarding class.

**Values** be, l2, af, l1, h2, ef, h1, nc

*profile* — The profile to assign to mirrored copy of the service traffic. The profile is used to determine the slope policy to use for the packet and determines the packet's drop precedence. Additionally, if marking is enabled, it determines the marking value to be used in the packet header. A value of in marks the traffic as in-profile traffic and results in use of high slope parameters. A value of out marks the traffic as out-of-profile and results in use of low slope parameters.

**Values** in, out

**Default** out

## far-end

**Syntax** **far-end** *ip-address* [**vc-id** *vc-id*] [**ing-svc-label** *ing-vc-label* | **tldp**]  
**no far-end** *ip-addr*

**Context** config>mirror>mirror-dest>remote-source

**Description** This command defines the remote device and configures parameters for mirror destination services on other devices allowed to mirror to the mirror destination service ID.

The **far-end** command is used within the context of the **remote-source** node. It allows the definition of accepted remote sources for mirrored packets to this *mirror-dest-service-id*. If a far end router has not been specified, packets sent to the router are discarded.

The **far-end** command is used to define a remote source that may send mirrored packets to this 7210 SAS for handling by this **mirror-dest** *service-id*.

The **ing-svc-label** keyword must be given to manually define the expected ingress service label. This ingress label must also be manually defined on the far end address through the **mirror-dest** SDP binding keyword **egr-svc-label**.

The **no** form of the command deletes a far end address from the allowed remote senders to this **mirror-dest** service. All **far-end** addresses are removed when **no remote-source** is executed. All signaled ingress service labels are withdrawn from the far end address affected. All manually defined *ing-svc-label* are removed.

**Default** No far end service ingress addresses are defined.

**Parameters** *ip-address* — The service IP address (system IP address) of the remote device sending mirrored traffic to

## Configuration Commands

this mirror destination service. If 0.0.0.0 is specified, any remote is allowed to send to this service.

**Values** 1.0.0.1 — 223.255.255.254

The ingress service label must be manually defined using the **ing-svc-label** keyword. On the far end 7210 SAS, the associated SDP **egr-svc-label** must be manually set and equal to the label defined in **ing-svc-label**.

**vc-id** *vc-id* — Specifies the virtual circuit identifier.

**Values** 1 — 4294967295

**ing-svc-label** *ing-svc-label* — Specifies the ingress service label for mirrored service traffic on the **far end** device for manually configured mirror service labels.

The defined *ing-svc-label* is entered into the ingress service label table which causes ingress packet with that service label to be handled by this **mirror-dest** service.

The specified *ing-svc-label* must not have been used for any other service ID and must match the far end expected specific *egr-svc-label* for this 7210 SAS. It must be within the range specified for manually configured service labels defined on this 7210 SAS. It may be reused for other far end addresses on this *mirror-dest-service-id*.

**Values** 2048 — 18431

**tldp** — Specifies that the label is obtained through signaling via the LDP.

## remote-source

**Syntax** [no] **remote-source**

**Context** config>mirror>mirror-dest

**Description** This command configures remote devices to mirror traffic to this device for mirror service egress. Optionally, deletes all previously defined remote mirror ingress devices.

The remote-source context allows the creation of a ‘sniffer farm’ to consolidate expensive packet capture and diagnostic tools to a central location. Remote areas of the access network can be monitored via normal service provisioning techniques.

Specific far-end routers can be specified with the **far-end** command allowing them to use this router as the destination for the same *mirror-dest-service-id*.

The **remote-source** node allows the source of mirrored packets to be on remote 7210 SAS devices. The local 7210 SAS will configure its network ports to forward packets associated with the *service-id* to the destination SAP. When **remote-source far-end** addresses are configured, an SDP is not allowed as a destination.

By default, the **remote-source** context contains no **far-end** addresses. When no **far-end** addresses have been specified, network remote devices will not be allowed to mirror packets to the local 7210 SAS as a mirror destination. Packets received from unspecified **far-end** addresses will be discarded at network ingress.

The **no** form of the command restores the *service-id* to the default condition to not allow a remote 7210 SAS access to the mirror destination. The **far-end** addresses are removed without warning.

**Default** No remote source devices defined

## sap

**Syntax**    **sap** *sap-id* [**create**]  
**no sap**

**Context**    config>mirror>mirror-dest

**Description**    This command creates a service access point (SAP) within a mirror destination service. The SAP is owned by the mirror destination service ID.

The SAP is defined with port and encapsulation parameters to uniquely identify the (mirror) SAP on the interface and within the box. The specified SAP must define an Ethernet port with a null SAP or a Dot1q SAP or a Q1.\* SAP.

Only one SAP can be created within a **mirror-dest** service ID. If the defined SAP has not been created on any service within the system, the SAP is created and the context of the CLI will change to the newly created SAP. In addition, the port cannot be a member of a multi-link bundle, LAG, APS group or IMA bundle.

If the defined SAP exists in the context of another service ID, **mirror-dest** or any other type, an error is generated.

Mirror destination SAPs can be created on Ethernet interfaces that have been defined as an access port or access-uplink port. If the interface is defined as network, the SAP creation returns an error.

**NOTE:** When using a dot1q SAP or a Q1.\* SAP as a mirror destination, users must allocated resources of another port for use by this features. Please refer the mirror configuration notes above [Configuration Notes on page 25](#).

When the **no** form of this command is used on a SAP created by a mirror destination service ID, the SAP with the specified port and encapsulation parameters is deleted.

**Default**    No default SAP for the mirror destination service defined.

**Parameters**    *sap-id* — Specifies the physical port identifier portion of the SAP definition. See [Common CLI Command Descriptions on page 345](#) for command syntax.

## service-name

**Syntax**    **service-name** *service-name*  
**no service-name**

**Context**    config>mirror>mirror-dest

**Description**    This command configures an optional service name, up to 64 characters in length, which adds a name identifier to a given service to then use that service name in configuration references as well as display and use service names in show commands throughout the system. This helps the service provider/administrator to identify and manage services within the 7210 SAS platforms.

All services are required to assign a service ID to initially create a service. However, either the service ID or the service name can be used o identify and reference a given service once it is initially created.

**Parameters**    *service-name* — Specifies a unique service name to identify the service. Service names may not begin with an integer (0-9).

## spoke-sdp

**Syntax** **spoke-sdp** *sdp-id:vc-id* [**create**] [**no-endpoint**]  
**spoke-sdp** *sdp-id:vc-id* [**create**] **endpoint** *name*  
**no sdp** *sdp-id:vc-id*

**Context** config>mirror>mirror-dest

**Description** This command binds an existing (mirror) service distribution path (SDP) to the mirror destination service ID.

The operational state of the SDP dictates the operational state of the SDP binding to the mirror destination. If the SDP is shutdown or operationally down, then SDP binding is down. Once the binding is defined and the service and SDP are operational, the far-end router defined in the **config service sdp sdp-id far-end** parameter is considered part of the service ID.

Only one SDP can be associated with a mirror destination service ID. If a second **sdp** command is executed after a successful SDP binding, an error occurs and the command has no effect on the existing configuration. A **no sdp** command must be issued before a new SDP binding can be attempted.

An SDP is a logical mechanism that ties a far end router to a specific service without having to define the far-end SAP. Each SDP represents a method to reach a router.

The other method is Multi-Protocol Label Switching (MPLS) encapsulation. router routers support both signaled and non-signaled LSPs (Label Switched Path) though the network. Non-signaled paths are defined at each hop through the network. Signaled paths are protocol communicated from end to end using RSVP. Paths may be manually defined or a constraint based routing protocol (OSPF-TE or CSPF) can be used to determine the best path with specific constraints.

SDPs are created and then bound to services. Many services can be bound to a single SDP. The operational and administrative state of the SDP controls the state of the SDP binding to the service.

An egress service label (Martini VC-Label), used by the SDP to differentiate each service bound to the SDP to the far-end router, must be obtained manually or through signaling with the far end. If manually configured, it must match the **ing-svc-label** defined for the local router.

**NOTE:** When using remote mirroring with spoke-SDP configured as a mirror destination, users must allocate resources of another port for use by this features. Please refer the mirror configuration notes above [Configuration Notes on page 25](#).

The **no** form of the command removes the SDP binding from the mirror destination service. Once removed, no packets are forwarded to the far-end (destination) router from that mirror destination service ID.

**Default** No default SDP ID is bound to a mirror destination service ID. If no SDP is bound to the service, the mirror destination will be local and cannot be to another router over the core network.

**Parameters** *sdp-id[:vc-id]* — A locally unique SDP identification (ID) number. The SDP ID must exist. If the SDP ID does not exist, an error will occur and the command will not execute.

For mirror services, the *vc-id* defaults to the *service-id*. However, there are scenarios where the *vc-id* is being used by another service. In this case, the SDP binding cannot be created. So, to avoid this, the mirror service SDP bindings now accepts *vc-ids*.

**Values** 1 — 17407

*vc-id* — Specifies the virtual circuit identifier.

**Values** 1 — 4294967295

**endpoint name** — specifies the name of the endpoint associated with the SAP.

**no endpoint** — Removes the association of a SAP or a SDP with an explicit endpoint name.

## egress

**Syntax** **egress**

**Context** config>mirror>mirror-dest>spoke-sdp

**Description** This command enters the context to configure spoke SDP egress parameters.

## vc-label

**Syntax** **vc-label** *egress-vc-label*  
**no vc-label** [*egress-vc-label*]

**Context** config>mirror>mirror-dest>spoke-sdp>egress

**Description** This command configures the spoke-SDP egress VC label.

**Parameters** *egress-vc-label* — A VC egress value that indicates a specific connection.

**Values** 16 — 1048575

## egress

**Syntax** **egress**

**Context** config> mirror> sap

**Description** This command provides the context to configure QoS egress policies for this SAP.

## qos

**Syntax** [**no**] **qos** *policy-id*

**Context** config> mirror> sap> egress

**Description** This command allows user to configure the QoS policy for the mirror destination SAP egress. The SAP egress QoS policy to use is specified using the *policy-id*> and must have been configured before associating

## Configuration Commands

this policy with the SAP. The SAP egress policy can be configured using the commands under the context `config> qos> sap-egress`.

When a SAP egress policy is associated with the SAP configured as a mirror destination, the queue associated with FC specified with the CLI command `config> mirror> mirror-dest> fc`, is used for traffic sent out of the mirror destination SAP. The policy allows the user to specify the amount of buffers, the WRED policy, the shaping rate and the marking values to use for the mirrored copy.

The `no` form of the command associates the default SAP egress QoS policy with the SAP.

**Default**     **no qos**

**Parameters**     *policy-id* — Specifies the QoS policy to associated with SAP egress. The QoS policy referred to by the *policy-id* is configured using the commands under `config> qos> sap-egress`.

## Mirror Source Configuration Commands

### mirror-source

**Syntax** [no] **mirror-source** *service-id*

**Context** debug

**Description** This command configures mirror source parameters for a mirrored service.

The **mirror-source** command is used to enable mirroring of packets specified by the association of the **mirror-source** to sources of packets defined within the context of the *mirror-dest-service-id*. The mirror destination service must already exist within the system.

A mirrored packet cannot be mirrored to multiple destinations. If a mirrored packet is properly referenced by multiple mirror sources (for example, a SAP on one **mirror-source** and a port on another **mirror-source**), then the packet is mirrored to a single *mirror-dest-service-id* based on the following hierarchy:

1. Filter entry
2. Service access port (SAP)
3. Physical port

The hierarchy is structured so the most specific match criteria has precedence over a less specific match. For example, if a **mirror-source** defines a port and a SAP on that port, then the SAP mirror-source is accepted and the mirror-source for the port is ignored because of the hierarchical order of precedence.

The **mirror-source** configuration is not saved when a configuration is saved. A **mirror-source** manually configured within an ASCII configuration file will not be preserved if that file is overwritten by a **save** command. Define the **mirror-source** within a file associated with a **config exec** command to make a **mirror-source** persistent between system reboots.

By default, all **mirror-dest** service IDs have a **mirror-source** associated with them. The **mirror-source** is not technically created with this command. Instead the service ID provides a contextual node for storing the current mirroring sources for the associated **mirror-dest** service ID. The **mirror-source** is created for the mirror service when the operator enters the **debug>mirror-source** *svcl* for the first time. The **mirror-source** is also automatically removed when the **mirror-dest** service ID is deleted from the system.

The **no** form of the command deletes all related source commands within the context of the **mirror-source** *service-id*. The command does not remove the service ID from the system.

**Default** No mirror source match criteria is defined for the mirror destination service.

**Parameters** *service-id* — The mirror destination service ID for which match criteria will be defined. The *service-id* must already exist within the system.

**Values** *service-id:* 1 — 2147483647

### ip-filter

**Syntax** **ip-filter** *ip-filter-id* **entry** *entry-id* [*entry-id* ...]  
**no ip-filter** *ip-filter-id* **entry** *entry-id*

**Context** debug>mirror-source

**Description** This command enables mirroring of packets that match specific entries in an existing IP filter.

The **ip-filter** command directs packets which match the defined list of entry IDs to be mirrored to the mirror destination referenced by the *mirror-dest-service-id* of the **mirror-source**.

The IP filter must already exist in order for the command to execute. Filters are configured in the **config>filter** context. If the IP filter does not exist, an error will occur. If the filter exists but has not been associated with a SAP or IP interface, an error is not generated but mirroring will not be enabled (there are no packets to mirror). Once the IP filter is defined to a SAP or IP interface, mirroring is enabled.

If the IP filter is defined as ingress, only ingress packets are mirrored. Ingress mirrored packets are mirrored to the mirror destination prior to any ingress packet modifications.

If the IP filter is defined as egress, only egress packets are mirrored. Egress mirrored packets are mirrored to the mirror destination after all egress packet modifications.

An *entry-id* within an IP filter can only be mirrored to a single mirror destination. If the same *entry-id* is defined multiple times, an error occurs and only the first **mirror-source** definition is in effect.

By default, no packets matching any IP filters are mirrored. Mirroring of IP filter entries must be explicitly defined.

The **no ip-filter** command, without the **entry** keyword, removes mirroring on all *entry-id*'s within the *ip-filter-id*.

When the **no** command is executed with the **entry** keyword and one or more *entry-id*'s, mirroring of that list of *entry-id*'s is terminated within the *ip-filter-id*. If an *entry-id* is listed that does not exist, an error will occur and the command will not execute. If an *entry-id* is listed that is not currently being mirrored, no error will occur for that *entry-id* and the command will execute normally.

**Default** IP filter mirroring is not defined.

**Parameters** *ip-filter-id* — The IP filter ID whose entries are mirrored. If the *ip-filter-id* does not exist, an error will occur and the command will not execute. Mirroring of packets will commence once the *ip-filter-id* is defined on a SAP or IP interface.

**Values** 1 - 65535

**entry** *entry-id* [*entry-id* ...] — The IP filter entries to use as match criteria for packet mirroring. The **entry** keyword begins a list of *entry-id*'s for mirroring. Multiple *entry-id* entries may be specified with a single command. Each *entry-id* must be separated by a space.

If an *entry-id* does not exist within the IP filter, an error occurs and the command will not execute.

If the filter's *entry-id* is renumbered within the IP filter definition, the old *entry-id* is removed but the new *entry-id* must be manually added to the configuration to include the new (renumbered) entry's criteria.

**Values** 1 - 65535

## ipv6-filter

**Syntax** **ipv6-filter** *ip-filter-id* **entry** *entry-id* [*entry-id* ...]  
**no ipv6-filter** *ip-filter-id* **entry** *entry-id*

**Context** debug>mirror-source

**Description** This command enables mirroring of packets that match specific entries in an existing IPv6 filter.

The **ipv6-filter** command directs packets which match the defined list of entry IDs to be mirrored to the mirror destination referenced by the *mirror-dest-service-id* of the **mirror-source**.

The IPv6 filter must already exist in order for the command to execute. Filters are configured in the **config>filter** context. If the IPv6 filter does not exist, an error will occur. If the filter exists but has not been associated with a SAP or IP interface, an error is not generated but mirroring will not be enabled (there are no packets to mirror). Once the IPv6 filter is defined to a SAP or IP interface, mirroring is enabled.

If the IPv6 filter is defined as ingress, only ingress packets are mirrored. Ingress mirrored packets are mirrored to the mirror destination prior to any ingress packet modifications.

If the IPv6 filter is defined as egress, only egress packets are mirrored. Egress mirrored packets are mirrored to the mirror destination after all egress packet modifications.

An *entry-id* within an IPv6 filter can only be mirrored to a single mirror destination. If the same *entry-id* is defined multiple times, an error occurs and only the first **mirror-source** definition is in effect.

By default, no packets matching any IPv6 filters are mirrored. Mirroring of IPv6 filter entries must be explicitly defined.

The **no ipv6-filter** command, without the **entry** keyword, removes mirroring on all *entry-id*'s within the *ipv6-filter-id*.

When the **no** command is executed with the **entry** keyword and one or more *entry-id*'s, mirroring of that list of *entry-id*'s is terminated within the *ipv6-filter-id*. If an *entry-id* is listed that does not exist, an error will occur and the command will not execute. If an *entry-id* is listed that is not currently being mirrored, no error will occur for that *entry-id* and the command will execute normally.

**Default** IPv6 filter mirroring is not defined.

**Parameters** *ipv6-filter-id* — The IPv6 filter ID whose entries are mirrored. If the *ipv6-filter-id* does not exist, an error will occur and the command will not execute. Mirroring of packets will commence once the *ipv6-filter-id* is defined on a SAP or IP interface.

**Values** 1 - 65535

**entry** *entry-id* [*entry-id* ...] — The IPv6 filter entries to use as match criteria for packet mirroring. The **entry** keyword begins a list of *entry-id*'s for mirroring. Multiple *entry-id* entries may be specified with a single command. Each *entry-id* must be separated by a space.

If an *entry-id* does not exist within the IPv6 filter, an error occurs and the command will not execute.

If the filter's *entry-id* is renumbered within the IPv6 filter definition, the old *entry-id* is removed but the new *entry-id* must be manually added to the configuration to include the new (renumbered) entry's criteria.

**Values** 1 - 65535

### mac-filter

**Syntax** **mac-filter** *mac-filter-id* **entry** *entry-id* [*entry-id* ...]  
**no mac-filter** *mac-filter-id*  
**no mac-filter** *mac-filter-id* **entry** *entry-id* [*entry-id* ...]

**Context** debug>mirror-source

**Description** This command enables mirroring of packets that match specific entries in an existing MAC filter. The **mac-filter** command directs packets which match the defined list of entry IDs to be mirrored to the mirror destination referenced by the *mirror-dest-service-id* of the **mirror-source**. The MAC filter must already exist in order for the command to execute. Filters are configured in the `config>filter` context. If the MAC filter does not exist, an error will occur. If the filter exists but has not been associated with a SAP or IP interface, an error is not be generated but mirroring will not be enabled (there are no packets to mirror). Once the filter is defined to a SAP or MAC interface, mirroring is enabled. If the MAC filter is defined as ingress, only ingress packets are mirrored. Ingress mirrored packets are mirrored to the mirror destination prior to any ingress packet modifications. The **no mac-filter** command, without the **entry** keyword, removes mirroring on all *entry-id*'s within the *mac-filter-id*. When the **no** command is executed with the **entry** keyword and one or more *entry-id*'s, mirroring of that list of *entry-id*'s is terminated within the *mac-filter-id*. If an *entry-id* is listed that does not exist, an error will occur and the command will not execute. If an *entry-id* is listed that is not currently being mirrored, no error will occur for that *entry-id* and the command will execute normally.

**Default** No MAC filter mirroring defined.

**Parameters** *mac-filter-id* — The MAC filter ID whose entries are mirrored. If the *mac-filter-id* does not exist, an error will occur and the command will not execute. Mirroring of packets will commence once the *mac-filter-id* is defined on a SAP.

**Values** 1 - 65535

**entry** *entry-id* [*entry-id* ...] — The MAC filter entries to use as match criteria for packet mirroring. The **entry** keyword begins a list of *entry-id*'s for mirroring. Multiple *entry-id* entries may be specified with a single command. Each *entry-id* must be separated by a space. Up to 8 entry IDs may be specified in a single command.

Each *entry-id* must exist within the *mac-filter-id*. If the *entry-id* is renumbered within the MAC filter definition, the old *entry-id* is removed from the list and the new *entry-id* will need to be manually added to the list if mirroring is still desired.

If no *entry-id* entries are specified in the command, mirroring will not occur for that MAC filter ID. The command will have no effect.

**Values** 1 - 65535

## port

**Syntax** **port** {*port-id* | **lag** *lag-id*} {[**egress**] [**ingress**]}  
**no port** {*port-id* | **lag** *lag-id*} [**egress**] [**ingress**]

**Context** debug>mirror-source

**Description** This command enables mirroring of traffic ingressing or egressing a port (Ethernet port, or Link Aggregation Group (LAG)).

The **port** command associates a port or LAG to a mirror source. The port is identified by the *port-id*. The defined port may be Ethernet, access or access uplink. access. A port may be a single port or a Link Aggregation Group (LAG) ID. When a LAG ID is given as the *port-id*, mirroring is enabled on all ports making up the LAG. Either a LAG port member *or* the LAG port can be mirrored.

The port is only referenced in the mirror source for mirroring purposes. If the port is removed from the system, the mirroring association will be removed from the mirror source.

The same port may not be associated with multiple mirror source definitions with the **ingress** parameter defined. The same port may not be associated with multiple mirror source definitions with the **egress** parameter defined.

If a SAP is mirrored on an access port, the SAP mirroring will have precedence over the access port mirroring when a packet matches the SAP mirroring criteria. Filter and label mirroring destinations will also precedence over a port-mirroring destination.

If the port is not associated with a **mirror-source**, packets on that port will not be mirrored. Mirroring may still be defined for a SAP or filter entry, which will mirror based on a more specific criteria.

The **no port** command disables port mirroring for the specified port. Mirroring of packets on the port may continue due to more specific mirror criteria. If the **egress** or **ingress** parameter keywords are specified in the **no** command, only the ingress or egress mirroring condition will be removed.

**Default** No ports are defined.

**Parameters** *port-id* — Specifies the port ID.

**Values** SAS-M,X,T -[1..26]  
 SAS-Mxp - [1..28]  
 SAS-R6 and SAS-R12- Depends on the type of IMM card used. For more information about the number of ports supported on different IMMs see, Systems Basic User Guide.

*lag-id* — The LAG identifier, expressed as a decimal integer.

**Values** SAS-M,X,T, Mxp-[1..25]  
 SAS-R6 and SAS-R12- [1..63]

**egress** — Specifies that packets egressing the port should be mirrored. Egress packets are mirrored to the mirror destination after egress packet modification.

**ingress** — Specifies that packets ingressing the port should be mirrored. Ingress packets are mirrored to the mirror destination prior to ingress packet modification.

## Configuration Commands

### sap

**Syntax**    **no sap** *sap-id* {[ingress] }  
              **no sap** *sap-id* {[ingress] }

**Context**    debug>mirror-source

**Description**    This command enables mirroring of traffic ingressing or egressing a service access port (SAP). A SAP that is defined within a mirror destination cannot be used in a mirror source. The mirror source SAP referenced by the *sap-id* is owned by the service ID of the service in which it was created. The SAP is only referenced in the mirror source name for mirroring purposes. The mirror source association does not need to be removed before deleting the SAP from its service ID. If the SAP is deleted from its service ID, the mirror association is removed from the mirror source.

More than one SAP can be associated within a single **mirror-source**. Each SAP has its own **ingress** parameter keywords to define which packets are mirrored to the mirror destination.

The SAP must be valid and properly configured. If the associated SAP does not exist, an error occurs and the command will not execute.

The same SAP cannot be associated with multiple mirror source definitions for ingress packets. If a particular SAP is not associated with a mirror source name, then that SAP will not have mirroring enabled for that mirror source.

The **no** form of the command disables mirroring for the specified SAP. All mirroring for that SAP on ingress and egress is terminated. Mirroring of packets on the SAP can continue if more specific mirror criteria is configured. If the **egress** or **ingress** parameter keywords are specified in the **no** command, only the ingress or egress mirroring condition is removed.

**Default**        No SAPs are defined by default.

**Parameters**    *sap-id* — Specifies the physical port identifier portion of the SAP definition. See [Common CLI Command Descriptions on page 345](#) for command syntax.

**ingress** — Specifies that packets ingressing the SAP should be mirrored. Ingress packets are mirrored to the mirror destination prior to ingress packet modification.

---

## Show Commands

### debug

**Syntax** `debug [application]`

**Context** `show`

**Description** This command displays set debug points.

**Parameters** *application* — Display which debug points have been set.

**Values:** service, ip, ospf, ospf3, mtrace, isis, mpls, rsvp, ldp, mirror, system, filter, subscriber-mgmt, radius, lag, oam

**Output**

```
*A:alul# show debug
debug
  mirror-source 101
    port 1/1/1 ingress
    no shutdown
  exit
  mirror-source 102
    port 1/1/3 egress
    no shutdown
  exit
exit
*A:alul#
```

### service-using

**Syntax** `service-using [mirror]`

**Context** `show>service`

**Description** Displays mirror services.

If no optional parameters are specified, all services defined on the system are displayed.

**Parameters** **mirror** — Displays mirror services.

**Output** **Show Service-Using Mirror** — The following table describes service-using mirror output fields:

Label	Description
Service Id	The service identifier.
Type	Specifies the service type configured for the service ID.
Adm	The desired state of the service.
Opr	The operating state of the service.

Label	Description (Continued)
CustomerID	The ID of the customer who owns this service.
Last Mgmt Change	The date and time of the most recent management-initiated change to this service.

**Sample Output**

```
A:ALA-48# show service service-using mirror
=====
Services [mirror]
=====
ServiceId   Type      Adm   Opr      CustomerId  Last Mgmt Change
-----
218         Mirror    Up    Down     1            04/08/2007 13:49:57
318         Mirror    Down  Down     1            04/08/2007 13:49:57
319         Mirror    Up    Down     1            04/08/2007 13:49:57
320         Mirror    Up    Down     1            04/08/2007 13:49:57
1000        Mirror    Down  Down     1            04/08/2007 13:49:57
1216        Mirror    Up    Down     1            04/08/2007 13:49:57
1412412     Mirror    Down  Down     1            04/08/2007 13:49:57
-----
Matching Services : 7
=====
A:ALA-48#
```

## mirror

**Syntax** `mirror mirror-dest service-id`

**Context** show

**Description** This command displays mirror configuration and operation information.

**Parameters** *service-id* — Specify the mirror service ID.

**Values** [1..2147483648] svc-name:64 char max

**Output** **Mirroring Output** — The following table describes the mirroring output fields:

Label	Description
Service Id	The service ID associated with this mirror destination.
Type	Entries in this table have an implied storage type of “volatile”. The configured mirror source information is not persistent.
Admin State	Up — The mirror destination is administratively enabled. Down — The mirror destination is administratively disabled.
Oper State	Up — The mirror destination is operationally enabled. Down — The mirror destination is operationally disabled.
Forwarding Class	The forwarding class for all packets transmitted to the mirror destination.
Remote Sources	Yes — A remote source is configured. No — A remote source is not configured.
Slice	The value of the slice-size, is the maximum portion of the mirrored frame that will be transmitted to the mirror destination. Any frame larger than the slice-size will be truncated to this value before transmission to the mirror destination. A value of 0 indicates that mirrored packet truncation based on slice size is disabled.
Destination SAP	The ID of the access port where the Service Access Point (SAP) associated with this mirror destination service is defined.
Egr QoS Policy	This value indicates the egress QoS policy ID. A value of 0 indicates that no QoS policy is specified.
mirror sources allowed	This value tells the user the type of mirror sources allowed to be configured.

**Sample Output**

```
*A:7210SAS>config>mirror>mirror-dest$ show mirror mirror-dest
```

```

=====
Mirror Services
=====
Id   Type   Adm   Opr   Destination          SDP Lbl/   Slice Mirror
                        SAP QoS      Src
                        Allowed
-----
1    Ether  Down  Down  None                 n/a        0    Local
1000 Ether  Up    Down  SDP 400 (1.1.1.1)    Pending    0    Local
2000 Ether  Up    Up    SAP 1/1/17:17       1          0    Remote
=====
*A:7210SAS>config>mirror>mirror-dest$

```

### Sample Output for Network mode

```

*A:7210SAS>config>mirror>mirror-dest$ show mirror mirror-dest 1
=====
Mirror Service
=====
Service Id       : 1                Type           : Ether
Description      : (Not Specified)
Admin State     : Down              Oper State      : Down
Mirror Sources Allowed : Local
Forwarding Class : be                Remote Sources: No
Profile         : out
Slice          : 0
=====
Mirror Services SDP
=====
SdpId      IP Addr      CfgLabel      Signal      EgrLabel
-----
No Matching Entries
=====

-----
Local Sources
-----
Admin State      : Up

No Mirror Sources configured
=====
*A:7210SAS>config>mirror>mirror-dest$

```

### Sample Output for Access-Uplink mode

```

*A:7210SAS# show mirror mirror-dest 1000
=====
Mirror Service
=====
Service Id       : 1000             Type           : Ether
Description      : (Not Specified)
Admin State     : Up                Oper State      : Down
Mirror Sources Allowed : Local
Profile         : out
=====

```

Destination SAP : 1/1/1

-----  
Local Sources  
-----

Admin State : Up

-Port 1/1/1 Ing

-----  
\*A:7210SAS#



# OAM and SAA

---

## In This Chapter

This chapter provides information about the Operations, Administration and Management (OAM) and Service Assurance Agent (SAA) commands available in the CLI for troubleshooting services.

Topics in this chapter include:

- [OAM Overview on page 74](#)
  - [LSP Diagnostics on page 75](#)
  - [SDP Diagnostics on page 76](#)
  - [Service Diagnostics on page 77](#)
  - [VPLS MAC Diagnostics on page 78](#)
  - [VLL Diagnostics on page 82](#)
- [Ethernet Connectivity Fault Management \(ETH-CFM\) on page 107](#)
- [Synthetic Loss Measurement \(ETH-SL\) on page 130](#)
- [Service Assurance Agent Overview on page 83](#)
  - [SAA Application on page 162](#)

## OAM Overview

Delivery of services requires a number of operations occur properly and at different levels in the service delivery model. For example, operations such as the association of packets to a service, must be performed properly in the forwarding plane for the service to function properly. In order to verify that a service is operational, a set of in-band, packet-based Operation, Administration, and Maintenance (OAM) tools is required, with the ability to test each of the individual packet operations.

For in-band testing, the OAM packets closely resemble customer packets to effectively test the customer's forwarding path, but they are distinguishable from customer packets so they are kept within the service provider's network and not forwarded to the customer.

The suite of OAM diagnostics supplement the basic IP ping and traceroute operations with diagnostics specialized for the different levels in the service delivery model. There are diagnostics for services. The following OAM features are not available on 7210 SAS-M and 7210 SAS-T devices configured in Access uplink mode:

- LSP Diagnostics
- SDP Diagnostics
- Service Diagnostics
- VPLS MAC Diagnostics
- VLL Diagnostics

---

## Two-Way Active Measurement Protocol (TWAMP)

Two-Way Active Measurement Protocol (TWAMP) provides a standards-based method for measuring the round-trip IP performance (packet loss, delay and jitter) between two devices. TWAMP uses the methodology and architecture of One-Way Active Measurement Protocol (OWAMP) to define a way to measure two-way or round-trip metrics.

There are four logical entities in TWAMP:

- The control-client
- The session-sender
- The server
- The session-reflector.

The control-client and session-sender are typically implemented in one physical device (the “client”) and the server and session-reflector in a second physical device (the “server”) with which the two-way measurements are being performed. The 7210 SAS acts as the server. The control-

client and server establishes a TCP connection and exchange TWAMP-Control messages over this connection. When the control-client requires to start testing, the client communicates the test parameters to the server. If the server corresponds to conduct the described tests, the test begins as soon as the client sends a Start-Sessions message. As part of a test, the session sender sends a stream of UDP-based test packets to the session-reflector, and the session reflector responds to each received packet with a response UDP-based test packet. When the session-sender receives the response packets from the session-reflector, the information is used to calculate two-way delay, packet loss, and packet delay variation between the two devices.

## Configuration Notes

The following are the configuration notes:

- Unauthenticated mode is supported. Encrypted and Authenticated modes are not supported.
- TWAMP is supported only in the base router instance.
- By default, 7210 uses TCP port number 862 to listen for TWAMP control connections and this is not user configurable.

---

## LSP Diagnostics

The 7210 SAS LSP diagnostics are implementations of LSP ping and LSP traceroute based on RFC 4379, *Detecting Multi-Protocol Label Switched (MPLS) Data Plane Failures*. LSP ping and LSP traceroute are modeled after the ICMP echo request/reply used by ping and traceroute to detect and localize faults in IP networks.

For a given FEC, LSP ping verifies whether the packet reaches the egress label edge router (LER), while in LSP traceroute mode, the packet is sent to the control plane of each transit label switched router (LSR) which performs various checks to see if it is actually a transit LSR for the path.

## SDP Diagnostics

The 7210 SAS SDP diagnostics are SDP ping and SDP MTU path discovery.

---

### SDP Ping

SDP ping performs in-band uni-directional or round-trip connectivity tests on SDPs. The SDP ping OAM packets are sent in-band, in the tunnel encapsulation, so it will follow the same path as traffic within the service. The SDP ping response can be received out-of-band in the control plane, or in-band using the data plane for a round-trip test.

For a uni-directional test, SDP ping tests:

- Egress SDP ID encapsulation
- Ability to reach the far-end IP address of the SDP ID within the SDP encapsulation
- Path MTU to the far-end IP address over the SDP ID
- Forwarding class mapping between the near-end SDP ID encapsulation and the far-end tunnel termination

For a round-trip test, SDP ping uses a local egress SDP ID and an expected remote SDP ID. Since SDPs are uni-directional tunnels, the remote SDP ID must be specified and must exist as a configured SDP ID on the far-end 7210 SAS M. SDP round trip testing is an extension of SDP connectivity testing with the additional ability to test:

- Remote SDP ID encapsulation
  - Potential service round trip time
  - Round trip path MTU
  - Round trip forwarding class mapping
- 

### SDP MTU Path Discovery

In a large network, network devices can support a variety of packet sizes that are transmitted across its interfaces. This capability is referred to as the Maximum Transmission Unit (MTU) of network interfaces. It is important to understand the MTU of the entire path end-to-end when provisioning services, especially for virtual leased line (VLL) services where the service must support the ability to transmit the largest customer packet.

The Path MTU discovery tool provides a powerful tool that enables service provider to get the exact MTU supported by the network's physical links between the service ingress and service termination points (accurate to one byte).

## Service Diagnostics

Alcatel-Lucent's Service ping feature provides end-to-end connectivity testing for an individual service. Service ping operates at a higher level than the SDP diagnostics in that it verifies an individual service and not the collection of services carried within an SDP.

Service ping is initiated from a 7210 SAS M router to verify round-trip connectivity and delay to the far-end of the service. Alcatel-Lucent's implementation functions for MPLS tunnels and tests the following from edge-to-edge:

- Tunnel connectivity
- VC label mapping verification
- Service existence
- Service provisioned parameter verification
- Round trip path verification
- Service dynamic configuration verification

## VPLS MAC Diagnostics

While the LSP ping, SDP ping and service ping tools enable transport tunnel testing and verify whether the correct transport tunnel is used, they do not provide the means to test the learning and forwarding functions on a per-VPLS-service basis.

It is conceivable, that while tunnels are operational and correctly bound to a service, an incorrect Forwarding Information Base (FIB) table for a service could cause connectivity issues in the service and not be detected by the ping tools. Alcatel-Lucent has developed VPLS OAM functionality to specifically test all the critical functions on a per-service basis. These tools are based primarily on the IETF document draft-stokes-vkompella-ppvpm-hvpls-oam-xx.txt, *Testing Hierarchical Virtual Private LAN Services*.

The VPLS OAM tools are:

- **MAC Ping** — Provides an end-to-end test to identify the egress customer-facing port where a customer MAC was learned. MAC ping can also be used with a broadcast MAC address to identify all egress points of a service for the specified broadcast MAC.
- **MAC Trace** — Provides the ability to trace a specified MAC address hop-by-hop until the last node in the service domain. An SAA test with MAC trace is considered successful when there is a reply from a far-end node indicating that they have the destination MAC address on an egress SAP or the CPM.
- **CPE Ping** — Provides the ability to check network connectivity to the specified client device within the VPLS. CPE ping will return the MAC address of the client, as well as the SAP and PE at which it was learned.
- **MAC Populate** — Allows specified MAC addresses to be injected in the VPLS service domain. This triggers learning of the injected MAC address by all participating nodes in the service. This tool is generally followed by MAC ping or MAC trace to verify if correct learning occurred.
- **MAC Purge** — Allows MAC addresses to be flushed from all nodes in a service domain.

---

## MAC Ping

For a MAC ping test, the destination MAC address (unicast or multicast) to be tested must be specified. A MAC ping packet can be sent through the control plane or the data plane. When sent by the control plane, the ping packet goes directly to the destination IP in a UDP/IP OAM packet. If it is sent by the data plane, the ping packet goes out with the data plane format.

In the control plane, a MAC ping is forwarded along the flooding domain if no MAC address bindings exist. If MAC address bindings exist, then the packet is forwarded along those paths (if they are active). Finally, a response is generated only when there is an egress SAP binding to that MAC address. A control plane request is responded to via a control reply only.

In the data plane, a MAC ping is sent with a VC label TTL of 255. This packet traverses each hop using forwarding plane information for next hop, VC label, etc. The VC label is swapped at each service-aware hop, and the VC TTL is decremented. If the VC TTL is decremented to 0, the packet is passed up to the management plane for processing. If the packet reaches an egress node, and would be forwarded out a customer facing port, it is identified by the OAM label below the VC label and passed to the management plane.

MAC pings are flooded when they are unknown at an intermediate node. They are responded to only by the egress nodes that have mappings for that MAC address.

---

## MAC Trace

A MAC trace functions like an LSP trace with some variations. Operations in a MAC trace are triggered when the VC TTL is decremented to 0.

Like a MAC ping, a MAC trace can be sent either by the control plane or the data plane.

For MAC trace requests sent by the control plane, the destination IP address is determined from the control plane mapping for the destination MAC. If the destination MAC is known to be at a specific remote site, then the far-end IP address of that SDP is used. If the destination MAC is not known, then the packet is sent unicast, to all SDPs in the service with the appropriate squelching.

A control plane MAC traceroute request is sent via UDP/IP. The destination UDP port is the LSP ping port. The source UDP port is whatever the system gives (note that this source UDP port is really the demultiplexor that identifies the particular instance that sent the request, when correlating the reply). The source IP address is the system IP of the sender.

When a traceroute request is sent via the data plane, the data plane format is used. The reply can be via the data plane or the control plane.

A data plane MAC traceroute request includes the tunnel encapsulation, the VC label, and the OAM, followed by an Ethernet DLC, a UDP and IP header. If the mapping for the MAC address is known at the sender, then the data plane request is sent down the known SDP with the appropriate tunnel encapsulation and VC label. If it is not known, then it is sent down every SDP (with the appropriate tunnel encapsulation per SDP and appropriate egress VC label per SDP binding).

The tunnel encapsulation TTL is set to 255. The VC label TTL is initially set to the min-ttl (default is 1). The OAM label TTL is set to 2. The destination IP address is the all-routers multicast address. The source IP address is the system IP of the sender.

The destination UDP port is the LSP ping port. The source UDP port is whatever the system gives (note that this source UDP port is really the demultiplexor that identifies the particular instance that sent the request, when correlating the reply).

The Reply Mode is either 3 (i.e., reply via the control plane) or 4 (i.e., reply through the data plane), depending on the reply-control option. By default, the data plane request is sent with Reply Mode 3 (control plane reply)Reply Mode 4 (data plane reply).

The Ethernet DLC header source MAC address is set to either the system MAC address (if no source MAC is specified) or to the specified source MAC. The destination MAC address is set to the specified destination MAC. The EtherType is set to IP.

---

## CPE Ping

The MAC ping OAM tool makes it possible to detect whether a particular MAC address has been learned in a VPLS.

The **cpe-ping** command extends this capability to detecting end-station IP addresses inside a VPLS. A CPE ping for a specific destination IP address within a VPLS will be translated to a MAC-ping towards a broadcast MAC address. Upon receiving such a MAC ping, each peer PE within the VPLS context will trigger an ARP request for the specific IP address. The PE receiving a response to this ARP request will report back to the requesting 7210 SAS M, X. It is encouraged to use the source IP address of 0.0.0.0 to prevent the provider's IP address of being learned by the CE.

## MAC Populate

MAC populate is used to send a message through the flooding domain to learn a MAC address as if a customer packet with that source MAC address had flooded the domain from that ingress point in the service. This allows the provider to craft a learning history and engineer packets in a particular way to test forwarding plane correctness.

The MAC populate request is sent with a VC TTL of 1, which means that it is received at the forwarding plane at the first hop and passed directly up to the management plane. The packet is then responded to by populating the MAC address in the forwarding plane, like a conventional learn although the MAC will be an OAM-type MAC in the FIB to distinguish it from customer MAC addresses.

This packet is then taken by the control plane and flooded out the flooding domain (squelching appropriately, the sender and other paths that would be squelched in a typical flood).

This controlled population of the FIB is very important to manage the expected results of an OAM test. The same functions are available by sending the OAM packet as a UDP/IP OAM packet. It is then forwarded to each hop and the management plane has to do the flooding.

Options for MAC populate are to force the MAC in the table to type OAM (in case it already existed as dynamic or static or an OAM induced learning with some other binding), to prevent new dynamic learning to over-write the existing OAM MAC entry, to allow customer packets with this MAC to either ingress or egress the network, while still using the OAM MAC entry.

Finally, an option to flood the MAC populate request causes each upstream node to learn the MAC, for example, populate the local FIB with an OAM MAC entry, and to flood the request along the data plane using the flooding domain.

An age can be provided to age a particular OAM MAC after a different interval than other MACs in a FIB.

---

## MAC Purge

MAC purge is used to clear the FIBs of any learned information for a particular MAC address. This allows one to do a controlled OAM test without learning induced by customer packets. In addition to clearing the FIB of a particular MAC address, the purge can also indicate to the control plane not to allow further learning from customer packets. This allows the FIB to be clean, and be populated only via a MAC Populate.

MAC purge follows the same flooding mechanism as the MAC populate.

A UDP/IP version of this command is also available that does not follow the forwarding notion of the flooding domain, but the control plane notion of it.

## VLL Diagnostics

---

### VCCV Ping

VCCV ping is used to check connectivity of a VLL in-band. It checks that the destination (target) PE is the egress for the Layer 2 FEC. It provides a cross-check between the data plane and the control plane. It is in-band, meaning that the VCCV ping message is sent using the same encapsulation and along the same path as user packets in that VLL. This is equivalent to the LSP ping for a VLL service. VCCV ping reuses an LSP ping message format and can be used to test a VLL configured over an MPLS SDP.

---

### VCCV-Ping Application

VCCV effectively creates an IP control channel within the pseudowire between PE1 and PE2. PE2 should be able to distinguish on the receive side VCCV control messages from user packets on that VLL. There are three possible methods of encapsulating a VCCV message in a VLL which translates into three types of control channels:

1. Use of a Router Alert Label immediately above the VC label. This method has the drawback that if ECMP is applied to the outer LSP label (for example, transport label), the VCCV message will not follow the same path as the user packets. This effectively means it will not troubleshoot the appropriate path. This method is supported by the 7210 SAS M.
2. Use of the OAM control word as illustrated in [Figure 7](#).

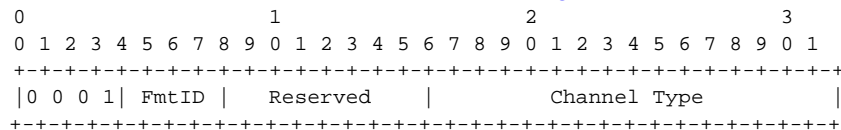

**Figure 7: OAM Control Word Format**

The first nibble is set to 0x1. The Format ID and the reserved fields are set to 0 and the channel type is the code point associated with the VCCV IP control channel as specified in the PWE3 IANA registry (RFC 4446). The channel type value of 0x21 indicates that the Associated Channel carries an IPv4 packet.

The use of the OAM control word assumes that the draft-martini control word is also used on the user packets. This means that if the control word is optional for a VLL and is not configured, the 7210 SAS M, X PE node will only advertise the router alert label as the CC capability in the Label Mapping message. This method is supported by the 7210 SAS M.

- Set the TTL in the VC label to 1 to force PE2 control plane to process the VCCV message. This method is not guaranteed to work under all circumstances. For instance, the draft mentions some implementations of penultimate hop popping overwrite the TTL field. This method is not supported by the 7210 SAS M.

When sending the label mapping message for the VLL, PE1 and PE2 must indicate which of the above OAM packet encapsulation methods (for example, which control channel type) they support. This is accomplished by including an optional VCCV TLV in the pseudowire FEC Interface Parameter field. The format of the VCCV TLV is shown in [Figure 8](#).

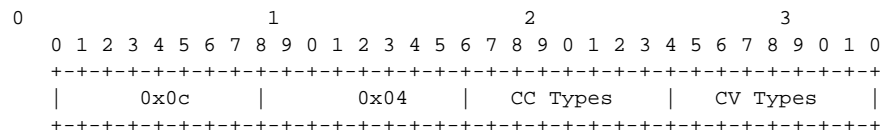

**Figure 8: VCCV TLV**

Note that the absence of the optional VCCV TLV in the Interface parameters field of the pseudowire FEC indicates the PE has no VCCV capability.

The Control Channel (CC) Type field is a bitmask used to indicate if the PE supports none, one, or many control channel types.

- 0x00 None of the following VCCV control channel types are supported
- 0x01 PWE3 OAM control word (see [Figure 7](#))
- 0x02 MPLS Router Alert Label
- 0x04 MPLS inner label TTL = 1

If both PE nodes support more than one of the CC types, then a 7210 SAS M PE will make use of the one with the lowest type value. For instance, OAM control word will be used in preference to the MPLS router alert label.

The Connectivity Verification (CV) bitmask field is used to indicate the specific type of VCCV packets to be sent over the VCCV control channel. The valid values are:

0x00 None of the below VCCV packet type are supported.

0x01 ICMP ping. Not applicable to a VLL over a MPLS SDP and as such is not supported by the 7210 SAS M.

0x02 LSP ping. This is used in VCCV-Ping application and applies to a VLL over an MPLS SDP. This is supported by the 7210 SAS M.

A VCCV ping is an LSP echo request message as defined in RFC 4379. It contains an L2 FEC stack TLV which must include within the sub-TLV type 10 “FEC 128 Pseudowire”. It also

contains a field which indicates to the destination PE which reply mode to use. There are four reply modes defined in RFC 4379:

Reply mode, meaning:

1. Do not reply. This mode is supported by the 7210 SAS M.
2. Reply via an IPv4/IPv6 UDP packet. This mode is supported by the 7210 SAS M.
3. Reply with an IPv4/IPv6 UDP packet with a router alert. This mode sets the router alert bit in the IP header and is not be confused with the CC type which makes use of the router alert label. This mode is not supported by the 7210 SAS M.
4. Reply via application level control channel. This mode sends the reply message inband over the pseudowire from PE2 to PE1. PE2 will encapsulate the Echo Reply message using the CC type negotiated with PE1. This mode is supported by the 7210 SAS M.

The reply is an LSP echo reply message as defined in RFC 4379. The message is sent as per the reply mode requested by PE1. The return codes supported are the same as those supported in the 7210 SAS M LSP ping capability.

The VCCV ping feature is in addition to the service ping OAM feature which can be used to test a service between 7210 SAS M nodes. The VCCV ping feature can test connectivity of a VLL with any third party node which is compliant to RFC 5085.

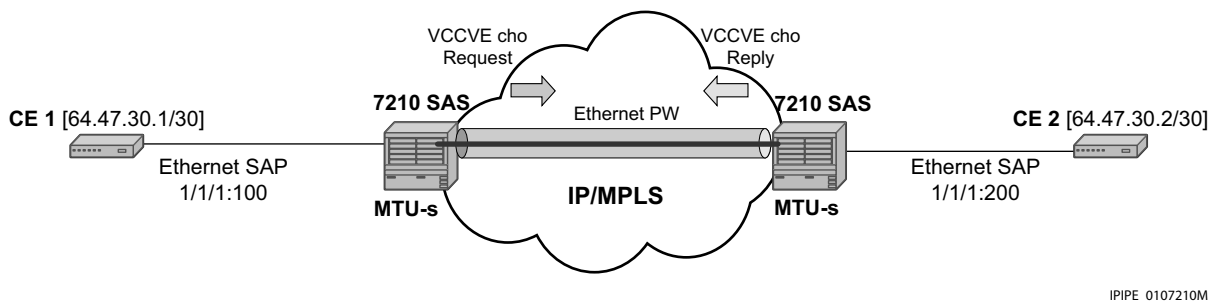

Figure 9: VCCV-Ping Application

## VCCV-Ping in a Multi-Segment Pseudowire

Pseudowire switching is a method for scaling a large network of VLL or VPLS services by removing the need for a full mesh of T-LDP sessions between the PE nodes as the number of these nodes grow over time. Pseudowire switching is also used whenever there is a need to deploy a VLL service across two separate routing domains.

In the network, a Termination PE (T-PE) is where the pseudowire originates and terminates. .

VCCV ping is extended to be able to perform the following OAM functions:

1. VCCV ping to a destination PE. A VLL FEC Ping is a message sent by T-PE1 to test the FEC at T-PE2. The operation at T-PE1 and T-PE2 is the same as in the case of a single-segment pseudowire. The pseudowire switching node, S-PE1, pops the outer label, swaps the inner (VC) label, decrements the TTL of the VC label, and pushes a new outer label. The 7210 SAS M PE1 node does not process the VCCV OAM Control Word unless the VC label TTL expires. In that case, the message is sent to the CPM for further validation and processing. This is the method described in draft-hart-pwe3-segmented-pw-vcv.

---

## Automated VCCV-Trace Capability for MS-Pseudowire

Although tracing of the MS-pseudowire path is possible using the methods explained in previous sections, these require multiple manual iterations and that the FEC of the last pseudowire segment to the target T-PE/S-PE be known a priori at the node originating the echo request message for each iteration. This mode of operation is referred to as a “ping” mode.

The automated VCCV-trace can trace the entire path of a pseudowire with a single command issued at the T-PE or at an S-PE. This is equivalent to LSP-trace and is an iterative process by which the ingress T-PE or T-PE sends successive VCCV-ping messages with incrementing the TTL value, starting from TTL=1.

The method is described in draft-hart-pwe3-segmented-pw-vcv, *VCCV Extensions for Segmented Pseudo-Wire*, and is pending acceptance by the PWE3 working group. In each iteration, the source T-PE or S-PE builds the MPLS echo request message in a way similar to [VCCV Ping on page 82](#). The first message with TTL=1 will have the next-hop S-PE T-LDP session source address in the Remote PE Address field in the pseudowire FEC TLV. Each S-PE which terminates and processes the message will include in the MPLS echo reply message the FEC 128 TLV corresponding the pseudowire segment to its downstream node. The inclusion of the FEC TLV in the echo reply message is allowed in RFC 4379, *Detecting Multi-Protocol Label Switched (MPLS) Data Plane Failures*. The source T-PE or S-PE can then build the next echo reply message with TTL=2 to test the next-next hop for the MS-pseudowire. It will copy the FEC TLV it received in the echo reply message into the new echo request message. The process is terminated when the reply is from the egress T-PE or when a timeout occurs. If specified, the max-ttl parameter in the vccv-trace command will stop on SPE before reaching T-PE.

The results VCCV-trace can be displayed for a fewer number of pseudowire segments of the end-to-end MS-pseudowire path. In this case, the min-ttl and max-ttl parameters are configured accordingly. However, the T-PE/S-PE node will still probe all hops upto min-ttl in order to correctly build the FEC of the desired subset of segments.

Note that this method does not require the use of the downstream mapping TLV in the echo request and echo reply messages.

---

### **VCCV for Static Pseudowire Segments**

MS pseudowire is supported with a mix of static and signaled pseudowire segments. However, VCCV ping and VCCV-trace is allowed until at least one segment of the MS pseudowire is static. Users cannot test a static segment but also, cannot test contiguous signaled segments of the MS-pseudowire. VCCV ping and VCCV trace is not supported in static-to-dynamic configurations.

## Detailed VCCV-Trace Operation

In [Figure on page 69](#) a trace can be performed on the MS-pseudowire originating from T-PE1 by a single operational command. The following process occurs:

1. T-PE1 sends a VCCV echo request with TTL set to 1 and a FEC 128 containing the pseudowire information of the first segment (pseudowire1 between T-PE1 and S-PE) to S-PE for validation.
2. S-PE validates the echo request with the FEC 128. Since it is a switching point between the first and second segment it builds an echo reply with a return code of 8 and includes the FEC 128 of the second segment (pseudowire2 between S-PE and T-PE2) and sends the echo reply back to T-PE1.
3. T-PE1 builds a second VCCV echo request based on the FEC128 in the echo reply from the S-PE. It increments the TTL and sends the next echo request out to T-PE2. Note that the VCCV echo request packet is switched at the S-PE datapath and forwarded to the next downstream segment without any involvement from the control plane.
4. T-PE2 receives and validates the echo request with the FEC 128 of the pseudowire2 from T-PE1. Since T-PE2 is the destination node or the egress node of the MS-pseudowire it replies to T-PE1 with an echo reply with a return code of 3 (egress router) and no FEC 128 is included.
5. T-PE1 receives the echo reply from T-PE2. T-PE1 is made aware that T-PE2 is the destination of the MS pseudowire because the echo reply does not contain the FEC 128 and because its return code is 3. The trace process is completed.

## Control Plane Processing of a VCCV Echo Message in a MS-Pseudowire

---

### Sending a VCCV Echo Request

When in the ping mode of operation, the sender of the echo request message requires the FEC of the last segment to the target S-PE/T-PE node. This information can either be configured manually or be obtained by inspecting the corresponding sub-TLV's of the pseudowire switching point TLV. However, the pseudowire switching point TLV is optional and there is no guarantee that all S-PE nodes will populate it with their system address and the pseudowire-id of the last pseudowire segment traversed by the label mapping message. Thus the 7210 SAS M implementation will always make use of the user configuration for these parameters.

---

### Receiving an VCCV Echo Request

Upon receiving a VCCV echo request the control plane on S-PEs (or the target node of each segment of the MS pseudowire) validates the request and responds to the request with an echo reply consisting of the FEC 128 of the next downstream segment and a return code of 8 (label switched at stack-depth) indicating that it is an S-PE and not the egress router for the MS-pseudowire.

If the node is the T-PE or the egress node of the MS-pseudowire, it responds to the echo request with an echo reply with a return code of 3 (egress router) and no FEC 128 is included.

---

### Receiving an VCCV Echo Reply

The operation to be taken by the node that receives the echo reply in response to its echo request depends on its current mode of operation such as ping or trace.

In ping mode, the node may choose to ignore the target FEC 128 in the echo reply and report only the return code to the operator.

## MPLS-TP On-Demand OAM Commands (Supported only on 7210 SAS-R6, 7210 SAS-R12 and 7210 SAS-T)

**NOTE:** This feature is supported on 7210 SAS-T network mode, 7210 SAS-R6, and 7210 SAS-R12 devices.

Ping and Trace tools for PWs and LSPs are supported with both IP encapsulation and the MPLS-TP on demand CV channel for non-IP encapsulation (0x025).

---

### MPLS-TP Pseudowires: VCCV-Ping/VCCV-Trace

For vccv-ping and vccv-trace commands:

- Sub-type **static** must be specified. This indicates to the system that the rest of the command contains parameters that are applied to a static PW with a static PW FEC.
- Add the ability to specify the non-IP ACH channel type (0x0025). This is known as the **non-ip control-channel**. This is the default for type static. GAL is not supported for PWs.
- If the ip-control-channel is specified as the encapsulation, then the IPv4 channel type is used (0x0021). In this case, a destination IP address in the 127/8 range is used, while the source address in the UDP/IP packet is set to the system IP address, or may be explicitly configured by the user with the src-ip-address option. This option is only valid if the IPv4 control-channel is specified.
- The reply mode are always assumed to be the same application level control channel type for type static.
- Allow an MPLS-TP global-id and node-id specified under the spoke-sdps with a given sdp-id:vc-id, used for MPLS-TP PW MEPs, or node-id (prefix) only for MIPs.
- The following CLI command description shows the options that are only allowed if the type static option is configured. All other options are blocked.
- As in the existing implementation, the downstream mapping and detailed downstream mapping TLVs (DSMAP/DDMAP TLVs) is not supported on PWs.

```
vccv-ping static <sdp-id:vc-id> [dest-global-id <global-id> dest-node-id <node-id>] [control-channel ipv4 | non-ip] [fc <fc-name> [profile {in|out}]] [size <octets>] [count <send-count>] [timeout <timeout>] [interval <interval>] [ttl <vc-label-ttl>][src-ip-address <ip-address>]
vccv-trace static <sdp-id:vc-id> [size <octets>][min-ttl <min-vc-label-ttl>][max-ttl <max-vc-label-ttl>][max-fail <no-response-count>][probe-count <probe-count>] [control-channel ipv4 | non-ip] [timeout <timeout-value>][interval <interval-value>][fc <fc-name> [profile {in|out}]] [src-ip-address <ip-address>] [detail]
```

If the spoke-sdp referred to by sdp-id:vc-id has an MPLS-TP PW-Path-ID defined, then those parameters are used to populate the static PW TLV in the target FEC stack of the vccv-ping or

vccv-trace packet. If a Global-ID and Node-ID are specified in the command, then these values are used to populate the destination node TLV in the vccv-ping or vccv-trace packet.

The global-id/node-id are only used as the target node identifiers if the vccv-ping is not end-to-end (for example, a TTL is specified in the vccv-ping/trace command and it is < 255); otherwise, the value in the PW Path ID is used. For vccv-ping, the dest-node-id may be entered as a 4-octet IP address <a.b.c.d> or 32-bit integer <1..4294967295>. For vccv-trace, the destination node-id and global-id are taken from the spoke-sdp context.

The same command syntax is applicable for SAA tests configured under configure saa test a type.

## MPLS-TP LSPs: LSP-Ping/LSP Trace

For lsp-ping and lsp-trace commands:

- The sub-type **static** must be specified. This indicates to the system that the rest of the command contains parameters specific to a LSP identified by a static LSP FEC.
- The 7210 SAS supports the use of the G-ACh with non-IP encapsulation or labeled encapsulation with IP de-multiplexing for both the echo request and echo reply for LSP-Ping and LSP-Trace on LSPs with a static LSP FEC (such as MPLS-TP LSPs).
- It is possible to specify the target MPLS-TP MEP/MIP identifier information for LSP Ping. If the target global-id and node-id are not included in the lsp-ping command, then these parameters for the target MEP ID are taken from the context of the LSP. The **tunnel-number** <tunnel-num> and **lsp-num** <lsp-num> for the far-end MEP are always taken from the context of the path under test.

```
lsp-ping static <lsp-name>
  [force]
  [path-type [active|working|protect]]
  [fc <fc-name> [profile {in|out}]]
  [size <octets>]
  [ttl <label-ttl>]
  [send-count <send-count>]
  [timeout <timeout>]
  [interval <interval>]
  [src-ip-address <ip-address>]
  [dest-global-id <dest-global-id> dest-node-id dest-node-id]
  [control-channel none | non-ip][detail]
lsp-trace static <lsp-name>
  [force]
  [path-type [active|working|protect]]
  [fc <fc-name> [profile {in|out}]]
  [max-fail <no-response-count>]
  [probe-count <probes-per-hop>]
  [size <octets>]
  [min-ttl <min-label-ttl>]
  [max-ttl <max-label-ttl>]
  [timeout <timeout>]
  [interval <interval>]
  [src-ip-address <ip-address>]
```

```
[control-channel none | non-ip]
[downstream-map-tlv <dsmmap|ddmap>]
[detail]
```

The following commands are only valid if the sub-type **static** option is configured, implying that `lsp-name` refers to an MPLS-TP tunnel LSP:

**path-type.** Values: active, working, protect. Default: active.

**dest-global-id** <global-id> **dest-node-id** <node-id>: Default: the **to** global-id:node-id from the LSP ID.

**control-channel:** If this is set to none, then IP encapsulation over an LSP is used with a destination address in the 127/8 range. The source address is set to the system IP address, unless the user specifies a source address using the `src-ip-address` option. If this is set to non-ip, then non-IP encapsulation over a G-ACh with channel type 0x00025 is used. This is the default for sub-type static. Note that the encapsulation used for the echo reply is the same as the encapsulation used for the echo request.

**downstream-map-tlv:** LSP Trace commands with this option can only be executed if the control-channel is set to none. The DSMAP/DDMAP TLV is only included in the echo request message if the egress interface is either a numbered IP interface, or an unnumbered IP interface. The TLV will not be included if the egress interface is of type **unnumbered-mpls-tp**.

For `lsp-ping`, the `dest-node-id` may be entered as a 4-octet IP address <a.b.c.d> or 32-bit integer <1..4294967295>. For `lsp-trace`, the destination node-id and global-id are taken from the spoke-sdp context.

The send mode and reply mode are always taken to be an application level control channel for MPLS-TP.

The **force** parameter causes an LSP ping echo request to be sent on an LSP that has been brought oper-down by BFD (LSP-Ping echo requests would normally be dropped on oper-down LSPs). This parameter is not applicable to SAA.

The LSP ID used in the LSP Ping packet is derived from a context lookup based on `lsp-name` and `path-type` (active/working/protect).

`Dest-global-id` and `dest-node-id` refer to the target global/node id. They do not need to be entered for end-to-end ping and trace, and the system will use the destination global id and node id from the LSP ID.

The same command syntax is applicable for SAA tests configured under **configure>saa>test**.

---

## MPLS-TP Show Commands

---

### Static MPLS Labels

The following new commands show the details of the static MPLS labels.

**show>router>mpls-labels>label <start-label> [<end-label> [in-use|<label-owner>]]**

**show>router>mpls-labels>label-range**

An example output is as follows:

```
*A:mlstp-dutA# show router mpls
mpls          mpls-labels
*A:mlstp-dutA# show router mpls label
label        label-range
*A:mlstp-dutA# show router mpls label-range

=====
Label Ranges
=====
Label Type      Start Label      End Label      Aging      Total Available
-----
Static-lsp      32               16415         -          16364
Static-svc      16416            32799         -          16376
Dynamic         32800            131071        0          98268
=====
```

---

### MPLS-TP Tunnel Configuration

These should show the configuration of a given tunnel.

**show>router>mpls>tp-lsp**

A sample output is as follows:

```
*A:mlstp-dutA# show router mpls tp-lsp
- tp-lsp [<lsp-name>] [status {up|down}] [from <ip-address>|to <ip-address>]
  [detail]
- tp-lsp [<lsp-name>] path [protect|working] [detail]
- tp-lsp [<lsp-name>] protection

<lsp-name>      : [32 chars max] - accepts * as wildcard char
<path>         : keyword - Display LSP path information.
<protection>   : keyword - Display LSP protection information.
<up|down>     : keywords - Specify state of the LSP
<ip-address>   : a.b.c.d
```

```

<detail>                : keyword - Display detailed information.
*A:mlstp-dutA# show router mpls tp-lsp
path
protection
to <a.b.c.d>
<lsp-name>
"lsp-32" "lsp-33" "lsp-34" "lsp-35" "lsp-36" "lsp-37" "lsp-38" "lsp-39"
"lsp-40" "lsp-41"
status {up|down}
from <ip-address>
detail

*A:mlstp-dutA# show router mpls tp-lsp "lsp-
"lsp-32" "lsp-33" "lsp-34" "lsp-35" "lsp-36" "lsp-37" "lsp-38" "lsp-39"
"lsp-40" "lsp-41"
*A:mlstp-dutA# show router mpls tp-lsp "lsp-32"

=====
MPLS MPLS-TP LSPs (Originating)
=====
LSP Name                To                Tun      Protect   Adm  Opr
                        Id                Id       Path
-----
lsp-32                  0.0.3.234        32       No        Up   Up
-----
LSPs : 1
=====
*A:mlstp-dutA# show router mpls tp-lsp "lsp-32" detail

=====
MPLS MPLS-TP LSPs (Originating) (Detail)
=====
Type : Originating
-----
LSP Name      : lsp-32
LSP Type      : MplsTp                LSP Tunnel ID : 32
From Node Id: 0.0.3.233+           To Node Id    : 0.0.3.234
Adm State     : Up                    Oper State     : Up
LSP Up Time  : 0d 04:50:47           LSP Down Time : 0d 00:00:00
Transitions  : 1                      Path Changes   : 2

DestGlobalId: 42                    DestTunnelNum  : 32

```

## MPLS-TP Path configuration.

This can reuse and augment the output of the current show commands for static LSPs. They should also show if BFD is enabled on a given path. If this referring to a transit path, this should also display (among others) the path-id (7 parameters) for a given transit-path-name, or the transit-path-name for a given the path-id (7 parameters)

```
show>router>mpls>tp-lsp>path
```

A sample output is as follows:

```

=====
*A:mlstp-dutA# show router mpls tp-lsp path
=====
MPLS-TP LSP Path Information
=====
LSP Name      : lsp-32                      To          : 0.0.3.234
Admin State   : Up                          Oper State   : Up

-----
Path          NextHop          InLabel    OutLabel    Out I/F      Admin Oper
-----
Working              32             32         AtoB_1      Up    Down
Protect             2080           2080       AtoC_1      Up    Up
=====
LSP Name      : lsp-33                      To          : 0.0.3.234
Admin State   : Up                          Oper State   : Up

-----
Path          NextHop          InLabel    OutLabel    Out I/F      Admin Oper
-----
Working              33             33         AtoB_1      Up    Down
Protect             2082           2082       AtoC_1      Up    Up
=====
LSP Name      : lsp-34                      To          : 0.0.3.234
Admin State   : Up                          Oper State   : Up

-----
Path          NextHop          InLabel    OutLabel    Out I/F      Admin Oper
-----
Working              34             34         AtoB_1      Up    Down
Protect             2084           2084       AtoC_1      Up    Up
=====
LSP Name      : lsp-35                      To          : 0.0.3.234
Admin State   : Up                          Oper State   : Up

-----
Path          NextHop          InLabel    OutLabel    Out I/F      Admin Oper
-----
Working              35             35         AtoB_1      Up    Down
Protect             2086           2086       AtoC_1      Up    Up
=====
LSP Name      : lsp-36                      To          : 0.0.3.234
Admin State   : Up                          Oper State   : Up

-----
Path          NextHop          InLabel    OutLabel    Out I/F      Admin Oper
-----
Working              36             36         AtoB_1      Up    Down
Protect             2088           2088       AtoC_1      Up    Up
=====
LSP Name      : lsp-37                      To          : 0.0.3.234
Admin State   : Up                          Oper State   : Up

-----
Path          NextHop          InLabel    OutLabel    Out I/F      Admin Oper
-----
Working              37             37         AtoB_1      Up    Down
Protect             2090           2090       AtoC_1      Up    Up

```

```

=====
LSP Name      : lsp-38                               To          : 0.0.3.234
Admin State   : Up                                  Oper State   : Up

-----
Path          NextHop          InLabel    OutLabel    Out I/F      Admin  Oper
-----
Working                               38         38         AtoB_1      Up     Down
Protect                               2092      2092      AtoC_1      Up     Up
=====

LSP Name      : lsp-39                               To          : 0.0.3.234
Admin State   : Up                                  Oper State   : Up

-----
Path          NextHop          InLabel    OutLabel    Out I/F      Admin  Oper
-----
Working                               39         39         AtoB_1      Up     Down
Protect                               2094      2094      AtoC_1      Up     Up
=====

LSP Name      : lsp-40                               To          : 0.0.3.234
Admin State   : Up                                  Oper State   : Up

-----
Path          NextHop          InLabel    OutLabel    Out I/F      Admin  Oper
-----
Working                               40         40         AtoB_1      Up     Down
Protect                               2096      2096      AtoC_1      Up     Up
=====

LSP Name      : lsp-41                               To          : 0.0.3.234
Admin State   : Up                                  Oper State   : Up

-----
Path          NextHop          InLabel    OutLabel    Out I/F      Admin  Oper
-----
Working                               41         41         AtoB_1      Up     Down
Protect                               2098      2098      AtoC_1      Up     Up

*A:mlstp-dutA# show router mpls tp-lsp "lsp-32" path working

=====
MPLS-TP LSP Working Path Information
  LSP: "lsp-32"
=====
LSP Name      : lsp-32                               To          : 0.0.3.234
Admin State   : Up                                  Oper State   : Up

-----
Path          NextHop          InLabel    OutLabel    Out I/F      Admin  Oper
-----
Working                               32         32         AtoB_1      Up     Down
=====

*A:mlstp-dutA# show router mpls tp-lsp "lsp-32" path protect

=====
MPLS-TP LSP Protect Path Information
  LSP: "lsp-32"
=====
LSP Name      : lsp-32                               To          : 0.0.3.234
Admin State   : Up                                  Oper State   : Up

```

```

-----
Path          NextHop          InLabel  OutLabel  Out I/F          Admin  Oper
-----
Protect              2080      2080      AtoC_1          Up     Up
-----
*A:mlstp-dutA# show router mpls tp-lsp "lsp-32" path protect detail

=====
MPLS-TP LSP Protect Path Information
  LSP: "lsp-32" (Detail)
=====
LSP Name       : lsp-32                               To           : 0.0.3.234
Admin State    : Up                                   Oper State    : Up

Protect path information
-----
Path Type      : Protect                               LSP Num      : 2
Path Admin     : Up                                   Path Oper     : Up
Out Interface  : AtoC_1                               Next Hop Addr : n/a
In Label       : 2080                                 Out Label     : 2080
Path Up Time   : 0d 04:52:17                          Path Dn Time  : 0d 00:00:00
Active Path    : Yes                                   Active Time   : 0d 00:52:56

MEP information
MEP State      : Up                                   BFD           : cc
OAM Templ     : privatebed-oam-template              CC Status     : inService
                                                       CV Status     : unknown
Protect Templ  : privatebed-protection-template      WTR Count Down: 0 seconds
RX PDU        : SF (1,1)                             TX PDU        : SF (1,1)
Defects       :

=====
*A:mlstp-dutA# show router mpls tp-lsp "lsp-32" path working detail

=====
MPLS-TP LSP Working Path Information
  LSP: "lsp-32" (Detail)
=====
LSP Name       : lsp-32                               To           : 0.0.3.234
Admin State    : Up                                   Oper State    : Up

Working path information
-----
Path Type      : Working                               LSP Num      : 1
Path Admin     : Up                                   Path Oper     : Down
Down Reason    : ccFault ifDn
Out Interface  : AtoB_1                               Next Hop Addr : n/a
In Label       : 32                                   Out Label     : 32
Path Up Time   : 0d 00:00:00                          Path Dn Time  : 0d 00:53:01
Active Path    : No                                   Active Time   : n/a

MEP information
MEP State      : Up                                   BFD           : cc
OAM Templ     : privatebed-oam-template              CC Status     : outOfService
                                                       CV Status     : unknown

=====
*A:mlstp-dutA#

```

## MPLS-TP Protection

These should show the protection configuration for a given tunnel, which path in a tunnel is currently working and which is protect, and whether the working or protect is currently active.

**show>router>mpls>tp-lsp>protection**

A sample output is as follows:

```
*A:mlstp-dutA# show router mpls tp-lsp protection

=====
MPLS-TP LSP Protection Information
Legend: W-Working, P-Protect,
=====
LSP Name                               Admin Oper Path   Ingr/Egr   Act. Rx PDU
                                State State  State Label    Path Tx PDU
-----
lsp-32                                Up   Up   W Down   32/32      No  SF (1,1)
                                           P Up     2080/2080 Yes  SF (1,1)
lsp-33                                Up   Up   W Down   33/33      No  SF (1,1)
                                           P Up     2082/2082 Yes  SF (1,1)
lsp-34                                Up   Up   W Down   34/34      No  SF (1,1)
                                           P Up     2084/2084 Yes  SF (1,1)
lsp-35                                Up   Up   W Down   35/35      No  SF (1,1)
                                           P Up     2086/2086 Yes  SF (1,1)
lsp-36                                Up   Up   W Down   36/36      No  SF (1,1)
                                           P Up     2088/2088 Yes  SF (1,1)
lsp-37                                Up   Up   W Down   37/37      No  SF (1,1)
                                           P Up     2090/2090 Yes  SF (1,1)
lsp-38                                Up   Up   W Down   38/38      No  SF (1,1)
                                           P Up     2092/2092 Yes  SF (1,1)
lsp-39                                Up   Up   W Down   39/39      No  SF (1,1)
                                           P Up     2094/2094 Yes  SF (1,1)
lsp-40                                Up   Up   W Down   40/40      No  SF (1,1)
                                           P Up     2096/2096 Yes  SF (1,1)
lsp-41                                Up   Up   W Down   41/41      No  SF (1,1)
                                           P Up     2098/2098 Yes  SF (1,1)
-----
No. of MPLS-TP LSPs: 10
=====
```

## BFD

The existing show>router>bfd context should be enhanced for MPLS-TP, as follows:

**show>router>bfd>mpls-tp-lsp**

Displays the MPLS –TP paths for which BFD is enabled.

**show>router>bfd>session [src <ip-address> [dest <ip-address> | detail]][mpls-tp-path <lsp-id...> [detail]]**

Should be enhanced to show the details of the BFD session on a particular MPLS-TP path, where lsp-id is the fully qualified lsp-id to which the BFD session is in associated.

A sample output is as follows:

```
*A:mlstp-dutA# show router bfd
- bfd

bfd-template      - Display BFD Template information
interface         - Display Interfaces with BFD
session           - Display session information

*A:mlstp-dutA# show router bfd bfd-template "privatebed-bfd-template"

=====
BFD Template privatebed-bfd-template
=====
Template Name      : privatebed-* Template Type      : cpmNp
Transmit Timer     : 10 msec      Receive Timer      : 10 msec
CV Transmit Interval : 1000 msec
Template Multiplier : 3          Echo Receive Interval : 100 msec

Mpls-tp Association
privatebed-oam-template
=====
* indicates that the corresponding row element may have been truncated.
*A:mlstp-dutA# show router bfd session

=====
BFD Session
=====
Interface/Lsp Name      State          Tx Intvl  Rx Intvl  Multipl
Remote Address/Info    Protocols     Tx Pkts   Rx Pkts   Type
-----
wp::lsp-32              Down (1)      1000      1000      3
0::0.0.0.0             mplsTp       N/A       N/A       cpm-np
wp::lsp-33              Down (1)      1000      1000      3
0::0.0.0.0             mplsTp       N/A       N/A       cpm-np
wp::lsp-34              Down (1)      1000      1000      3
0::0.0.0.0             mplsTp       N/A       N/A       cpm-np
wp::lsp-35              Down (1)      1000      1000      3
0::0.0.0.0             mplsTp       N/A       N/A       cpm-np
wp::lsp-36              Down (1)      1000      1000      3
0::0.0.0.0             mplsTp       N/A       N/A       cpm-np
wp::lsp-37              Down (1)      1000      1000      3
0::0.0.0.0             mplsTp       N/A       N/A       cpm-np
wp::lsp-38              Down (1)      1000      1000      3
0::0.0.0.0             mplsTp       N/A       N/A       cpm-np
wp::lsp-39              Down (1)      1000      1000      3
0::0.0.0.0             mplsTp       N/A       N/A       cpm-np
wp::lsp-40              Down (1)      1000      1000      3
0::0.0.0.0             mplsTp       N/A       N/A       cpm-np
wp::lsp-41              Down (1)      1000      1000      3
0::0.0.0.0             mplsTp       N/A       N/A       cpm-np
```

```

pp::lsp-32          Up (3)          1000      1000      3
  0::0.0.0.0       mplsTp        N/A       N/A       cpm-np
pp::lsp-33          Up (3)          1000      1000      3
  0::0.0.0.0       mplsTp        N/A       N/A       cpm-np
pp::lsp-34          Up (3)          1000      1000      3
  0::0.0.0.0       mplsTp        N/A       N/A       cpm-np
pp::lsp-35          Up (3)          1000      1000      3
  0::0.0.0.0       mplsTp        N/A       N/A       cpm-np
pp::lsp-36          Up (3)          1000      1000      3
  0::0.0.0.0       mplsTp        N/A       N/A       cpm-np
pp::lsp-37          Up (3)          1000      1000      3
  0::0.0.0.0       mplsTp        N/A       N/A       cpm-np
pp::lsp-38          Up (3)          1000      1000      3
  0::0.0.0.0       mplsTp        N/A       N/A       cpm-np
pp::lsp-39          Up (3)          1000      1000      3
  0::0.0.0.0       mplsTp        N/A       N/A       cpm-np
pp::lsp-40          Up (3)          1000      1000      3
  0::0.0.0.0       mplsTp        N/A       N/A       cpm-np
pp::lsp-41          Up (3)          1000      1000      3
  0::0.0.0.0       mplsTp        N/A       N/A       cpm-np
-----
No. of BFD sessions: 20
-----
wp = Working path   pp = Protecting path
=====

```

## MPLS TP Node Configuration

Displays the Global ID, Node ID and other general MPLS-TP configurations for the node.

**show>router>mpls>mpls-tp**

A sample output is as follows:

```

*A:mlstp-dutA# show router mpls mpls-tp
- mpls-tp

oam-template      - Display MPLS-TP OAM Template information
protection-tem*   - Display MPLS-TP Protection Template information
status            - Display MPLS-TP system configuration
transit-path      - Display MPLS-TP Tunnel information

*A:mlstp-dutA# show router mpls mpls-tp oam-template

=====
MPLS-TP OAM Templates
=====
Template Name : privatebed-oam-template Router ID      : 1
BFD Template  : privatebed-bfd-template Hold-Down Time: 0 centiseconds
                                           Hold-Up Time  : 20 deciseconds
=====
*A:mlstp-dutA# show router mpls mpls-tp protection-template
=====

```

## OAM Overview

```
MPLS-TP Protection Templates
=====
Template Name : privatebed-protection-template Router ID      : 1
Protection Mode: one2one                               Direction      : bidirectional
Revertive      : revertive                             Wait-to-Restore: 300sec
Rapid-PSC-Timer: 10ms                                Slow-PSC-Timer : 5sec
=====
*A:mlstp-dutA# show router mpls mpls-tp status

=====
MPLS-TP Status
=====
Admin Status  : Up
Global ID     : 42                               Node ID       : 0.0.3.233
Tunnel Id Min : 1                               Tunnel Id Max : 4096
=====
*A:mlstp-dutA# show router mpls mpls-tp transit-path
  - transit-path [<path-name>] [detail]

<path-name>      : [32 chars max]
<detail>         : keyword - Display detailed information.

A:mlstp-dutC# show router mpls mpls-tp transit-path
  - transit-path [<path-name>] [detail]

<path-name>      : [32 chars max]
<detail>         : keyword - Display detailed information.

A:mlstp-dutC# show router mpls mpls-tp transit-path
<path-name>
"tp-32" "tp-33" "tp-34" "tp-35" "tp-36" "tp-37" "tp-38" "tp-39"
"tp-40" "tp-41"
detail

A:mlstp-dutC# show router mpls mpls-tp transit-path "tp-32"

=====
MPLS-TP Transit tp-32 Path Information
=====
Path Name      : tp-32
Admin State    : Up                               Oper State     : Up

-----
Path           NextHop           InLabel  OutLabel  Out I/F
-----
FP             2080             2081     CtoB_1
RP             2081             2080     CtoA_1
=====
A:mlstp-dutC# show router mpls mpls-tp transit-path "tp-32" detail

=====
MPLS-TP Transit tp-32 Path Information (Detail)
=====
Path Name      : tp-32
```

```

Admin State   : Up                               Oper State    : Up
-----
Path ID configuration
Src Global ID : 42                               Dst Global ID : 42
Src Node ID   : 0.0.3.234                       Dst Node ID   : 0.0.3.233
LSP Number    : 2                               Dst Tunnel Num: 32

Forward Path configuration
In Label      : 2080                             Out Label     : 2081
Out Interface : CtoB_1                           Next Hop Addr : n/a

Reverse Path configuration
In Label      : 2081                             Out Label     : 2080
Out Interface : CtoA_1                           Next Hop Addr : n/a
=====
A:mlstp-dutC#

```

---

## MPLS-TP Interfaces

The existing show>router>interface command should be enhanced to display mpls-tp specific information.

The following is a sample output:

```

*A:mlstp-dutA# show router interface "AtoB_1"

=====
Interface Table (Router: Base)
=====
Interface-Name      Adm      Opr(v4/v6)  Mode      Port/SapId
  IP-Address                               PfxState
-----
AtoB_1              Down     Down/--     Network  1/2/3:1
  Unnumbered If[system]                    n/a
-----
Interfaces : 1

```

---

## Services using MPLS-TP PWs

The show>service command should be updated to display MPLS-TP specific information such as the PW Path ID and control channel status signaling parameters.

The following is a sample output:

```

*A:mlstp-dutA# show service id 1 all

=====
Service Detailed Information
=====
Service Id          : 1                               Vpn Id        : 0

```

# OAM Overview

```
Service Type      : Epipe
Name              : (Not Specified)
Description       : (Not Specified)
Customer Id      : 1
Creation Origin   : manual
Last Status Change: 12/03/2012 15:26:20
Last Mgmt Change : 12/03/2012 15:24:57
Admin State      : Up
Oper State       : Up
MTU              : 1514
Vc Switching    : False
SAP Count       : 1
SDP Bind Count   : 1
Per Svc Hashing : Disabled
Force QTag Fwd  : Disabled
```

-----  
ETH-CFM service specifics  
-----

```
Tunnel Faults    : ignore
```

-----  
Service Destination Points(SDPs)  
-----

```
Sdp Id 32:1  -(0.0.3.234:42)
```

```
-----
Description      : (Not Specified)
SDP Id           : 32:1
Type             : Spoke
Spoke Descr     : (Not Specified)
VC Type         : Ether
VC Tag          : n/a
Admin Path MTU  : 0
Oper Path MTU   : 9186
Delivery        : MPLS
Far End         : 0.0.3.234:42
Tunnel Far End  : n/a
LSP Types       : MPLSTP
Hash Label      : Disabled
Hash Lbl Sig Cap : Disabled
Oper Hash Label : Disabled

Admin State      : Up
Oper State       : Up
Acct. Pol       : None
Collect Stats   : Disabled
Ingress Label   : 16416
Egress Label    : 16416
Ingr Mac Fltr-Id : n/a
Egr Mac Fltr-Id : n/a
Ingr IP Fltr-Id : n/a
Egr IP Fltr-Id  : n/a
Ingr IPv6 Fltr-Id : n/a
Egr IPv6 Fltr-Id : n/a
Admin ControlWord : Preferred
Oper ControlWord : True
Admin BW(Kbps)  : 0
Oper BW(Kbps)   : 0
Last Status Change : 12/03/2012 15:26:20
Signaling       : None
Last Mgmt Change : 12/03/2012 15:24:57
Force Vlan-Vc   : Disabled
Endpoint        : N/A
Precedence      : 4
PW Status Sig   : Enabled
Class Fwding State : Down
Flags           : None
Local Pw Bits   : None
Peer Pw Bits    : None
Peer Fault Ip   : None
Peer Vccv CV Bits : None
Peer Vccv CC Bits : None
Application Profile: None
Standby Sig Slave : False
Block On Peer Fault: False
```

```

Ingress Qos Policy : (none)                Egress Qos Policy : (none)
Ingress FP QGrp   : (none)                Egress Port QGrp  : (none)
Ing FP QGrp Inst  : (none)                Egr Port QGrp Inst: (none)

Statistics      :
I. Fwd. Pkts.   : 272969957              I. Dro. Pkts.     : 0
E. Fwd. Pkts.   : 273017433              E. Fwd. Octets    : 16381033352

```

```
-----
Control Channel Status
-----
```

```

PW Status          : enabled                Refresh Timer      : 66 secs
Peer Status Expire : false                  Clear On Timeout  : true

```

```
-----
SDP-BIND PW Path Information
-----
```

```

AGI                 : 1:1
SAII Type2          : 42:0.0.3.234:1
TAII Type2          : 42:0.0.3.233:1

```

```
-----
RSVP/Static LSPs
-----
```

```
Associated LSP List :
```

```

Lsp Name           : lsp-32
Admin State        : Up                    Oper State         : Up

```

```
*A:mlstp-dutA# show service id [1..4] all | match "Control Channel" pre-lines 1 post-lines 5
```

```
-----
Control Channel Status
-----
```

```

PW Status          : enabled                Refresh Timer      : 66 secs
Peer Status Expire : false                  Clear On Timeout  : true

```

```
-----
Control Channel Status
-----
```

```

PW Status          : enabled                Refresh Timer      : 66 secs
Peer Status Expire : false                  Clear On Timeout  : true

```

```
-----
Control Channel Status
-----
```

```

PW Status          : enabled                Refresh Timer      : 66 secs
Peer Status Expire : false                  Clear On Timeout  : true

```

```
-----
Control Channel Status
-----
```

```

PW Status          : enabled                Refresh Timer      : 66 secs
Peer Status Expire : false                  Clear On Timeout  : true

```

```
*A:mlstp-dutA# show service id [1..4] all | match SDP-BIND pre-lines 1 post-lines 5
```

```

-----
SDP-BIND PW Path Information
-----
AGI                : 1:1
SAII Type2         : 42:0.0.3.234:1
TAII Type2         : 42:0.0.3.233:1

-----
SDP-BIND PW Path Information
-----
AGI                : 1:2
SAII Type2         : 42:0.0.3.234:2
TAII Type2         : 42:0.0.3.233:2

-----
SDP-BIND PW Path Information
-----
AGI                : 1:3
SAII Type2         : 42:0.0.3.234:3
TAII Type2         : 42:0.0.3.233:3

-----
SDP-BIND PW Path Information
-----
AGI                : 1:4
SAII Type2         : 42:0.0.3.234:4
TAII Type2         : 42:0.0.3.233:4

```

## MPLS-TP DEBUG COMMANDS

The following command provides the debug command for an MPLS-TP tunnel:

**tools>dump>router>mpls>tp-tunnel <lsp-name> [clear]**

The following is a sample output:

```

A:mlstp-dutA# tools dump router mpls tp-tunnel
- tp-tunnel <lsp-name> [clear]
- tp-tunnel id <tunnel-id> [clear]
<lsp-name> : [32 chars max]
<tunnel-id> : [1..61440]
<clear> : keyword - clear stats after reading
*A:mlstp-dutA# tools dump router mpls tp-tunnel "lsp-
"lsp-32" "lsp-33" "lsp-34" "lsp-35" "lsp-36" "lsp-37" "lsp-38" "lsp-39"
"lsp-40" "lsp-41"
*A:mlstp-dutA# tools dump router mpls tp-tunnel "lsp-32"
Idx: 1-32 (Up/Up): pgId 4, paths 2, operChg 1, Active: Protect
TunnelId: 42::0.0.3.233::32-42::0.0.3.234::32
PgState: Dn, Cnt/Tm: Dn 1/000 04:00:48.160 Up:3/000 00:01:25.840
MplsMsg: tpDn 0/000 00:00:00.000, tunDn 0/000 00:00:00.000
wpDn 0/000 00:00:00.000, ppDn 0/000 00:00:00.000
wpDel 0/000 00:00:00.000, ppDel 0/000 00:00:00.000
tunUp 1/000 00:00:02.070
Paths:
Work (Up/Dn): Lsp 1, Lbl 32/32, If 2/128 (1/2/3 : 0.0.0.0)

```

```

Tmpl: ptc: , oam: privatebed-oam-template (bfd: privatebed-bfd-template(np)-10 ms)
Bfd: Mode CC state Dn/Up handle 160005/0
Bfd-CC (Cnt/Tm): Dn 1/000 04:00:48.160 Up:1/000 00:01:23.970
State: Admin Up (1::1::1) port Up , if Dn , operChg 2
DnReasons: ccFault ifDn
Protect (Up/Up): Lsp 2, Lbl 2080/2080, If 3/127 (5/1/1 : 0.0.0.0)
Tmpl: ptc: privatebed-protection-template, oam: privatebed-oam-template (bfd: privatebed-
bfd-template(np)-10 ms)
Bfd: Mode CC state Up/Up handle 160006/0
Bfd-CC (Cnt/Tm): Dn 0/000 00:00:00.000 Up:1/000 00:01:25.410
State: Admin Up (1::1::1) port Up , if Up , operChg 1
Aps: Rx - 5, raw 3616, nok 0(), txRaw - 3636, revert Y
Pdu: Rx - 0x1a-21::0101 (SF), Tx - 0x1a-21::0101 (SF)
State: PF:W:L LastEvt pdu (L-SFw/R-SFw)
Tmrs: slow
Defects: None Now: 000 05:02:19.130
Seq Event state TxPdu RxPdu Dir Act Time
=== =====
000 start UA:P:L SF (0,0) NR (0,0) Tx--> Work 000 00:00:02.080
001 pdu UA:P:L SF (0,0) SF (0,0) Rx<-- Work 000 00:01:24.860
002 pdu UA:P:L SF (0,0) NR (0,0) Rx<-- Work 000 00:01:26.860
003 pUp NR NR (0,0) NR (0,0) Tx--> Work 000 00:01:27.440
004 pdu NR NR (0,0) NR (0,0) Rx<-- Work 000 00:01:28.760
005 wDn PF:W:L SF (1,1) NR (0,0) Tx--> Prot 000 04:00:48.160
006 pdu PF:W:L SF (1,1) NR (0,1) Rx<-- Prot 000 04:00:48.160
007 pdu PF:W:L SF (1,1) SF (1,1) Rx<-- Prot 000 04:00:51.080

```

The following command shows the free MPLS tunnel ID's

```

A:SASR1# /tools dump router mpls mpls-tp check-lbl-range
- mpls-tp check-lbl-range <range1> <range2>

<check-lbl-range>      : keyword
<range1>                : [32..65520]
<range2>                : [32..65520]

```

The following command provides a debug tool to view control-channel-status signaling packets.

```

*A:7210SAS# /debug service id 700 sdp 200:700 event-type ?{config-change|oper-status-
change|neighbor-discovery|control-channel-status}

*A:7210SAS# /debug service id 700 sdp 200:700 event-type control-channel-status

*A:7210SAS#
1 2012/08/31 09:56:12.09 EST MINOR: DEBUG #2001 Base PW STATUS SIG PKT (RX):
"PW STATUS SIG PKT (RX)::
Sdp Bind 200:700 Instance 3
  Version          : 0x0
  PW OAM Msg Type  : 0x27
  Refresh Time     : 0xa
  Total TLV Length : 0x8
  Flags            : 0x0
  TLV Type         : 0x96a
  TLV Len          : 0x4
  PW Status Bits   : 0x0
"

2 2012/08/31 09:56:22.09 EST MINOR: DEBUG #2001 Base PW STATUS SIG PKT (RX):

```

## OAM Overview

```
"PW STATUS SIG PKT (RX)::
Sdp Bind 200:700 Instance 3
  Version      : 0x0
  PW OAM Msg Type : 0x27
  Refresh Time  : 0xa
  Total TLV Length : 0x8
  Flags        : 0x0
  TLV Type     : 0x96a
  TLV Len      : 0x4
  PW Status Bits : 0x0
"

3 2012/08/31 09:56:29.44 EST MINOR: DEBUG #2001 Base PW STATUS SIG PKT (TX):
"PW STATUS SIG PKT (TX)::
Sdp Bind 200:700 Instance 3
  Version      : 0x0
  PW OAM Msg Type : 0x27
  Refresh Time  : 0x1e
  Total TLV Length : 0x8
  Flags        : 0x0
  TLV Type     : 0x96a
  TLV Len      : 0x4
  PW Status Bits : 0x0
```

## Ethernet Connectivity Fault Management (ETH-CFM)

The IEEE and the ITU-T have cooperated to define the protocols, procedures and managed objects to support service based fault management. Both IEEE 802.1ag standard and the ITU-T Y.1731 recommendation support a common set of tools that allow operators to deploy the necessary administrative constructs, management entities and functionality, Ethernet Connectivity Fault Management (ETH-CFM). The ITU-T has also implemented a set of advanced ETH-CFM and performance management functions and features that build on the proactive and on demand troubleshooting tools.

CFM uses Ethernet frames and is distinguishable by ether-type 0x8902. In certain cases the different functions will use a reserved multicast address that could also be used to identify specific functions at the MAC layer. However, the multicast MAC addressing is not used for every function or in every case. The Operational Code (OpCode) in the common CFM header is used to identify the type of function carried in the CFM packet. CFM frames are only processed by IEEE MAC bridges. With CFM, interoperability can be achieved between different vendor equipment in the service provider network upto and including customer premises bridges. The following table lists CFM-related acronyms used in this section.

IEEE 802.1ag and ITU-T Y.1731 functions that are implemented are available on the 7210 SAS platforms.

Acronym	Callout
IDM	One way Delay Measurement (Y.1731)
AIS	Alarm Indication Signal
CCM	Continuity check message
CFM	Connectivity fault management
DMM	Delay Measurement Message (Y.1731)
DMR	Delay Measurement Reply (Y.1731)
LBM	Loopback message
LBR	Loopback reply
LTM	Linktrace message
LTR	Linktrace reply
ME	Maintenance entity
MA	Maintenance association

<b>Acronym</b>	<b>Callout (Continued)</b>
MA-ID	Maintenance association identifier
MD	Maintenance domain
MEP	Maintenance association end point
MEP-ID	Maintenance association end point identifier
MHF	MIP half function
MIP	Maintenance domain intermediate point
OpCode	Operational Code
RDI	Remote Defect Indication
TST	Ethernet Test (Y.1731)

## ETH-CFM Building Blocks

The IEEE and the ITU-T use their own nomenclature when describing administrative contexts and functions. This introduces a level of complexity to configuration, discussion and different vendors naming conventions. The 7210 SAS OS CLI has chosen to standardize on the IEEE 802.1ag naming where overlap exists. ITU-T naming is used when no equivalent is available in the IEEE standard. In the following definitions, both the IEEE name and ITU-T names are provided for completeness, using the format IEEE Name/ITU-T Name.

Maintenance Domain (MD)/Maintenance Entity (ME) is the administrative container that defines the scope, reach and boundary for faults. It is typically the area of ownership and management responsibility. The IEEE allows for various formats to name the domain, allowing upto 45 characters, depending on the format selected. ITU-T supports only a format of “none” and does not accept the IEEE naming conventions.

0 — Undefined and reserved by the IEEE.

1 — No domain name. It is the only format supported by Y.1731 as the ITU-T specification does not use the domain name. This is supported in the IEEE 802.1ag standard but not in currently implemented for 802.1ag defined contexts.

2,3,4 — Provides the ability to input various different textual formats, upto 45 characters. The string format (2) is the default and therefore the keyword is not shown when looking at the configuration.

Maintenance Association (MA)/Maintenance Entity Group (MEG) is the construct where the different management entities will be contained. Each MA is uniquely identified by its MA-ID. The MA-ID is comprised of the by the MD level and MA name and associated format. This is another administrative context where the linkage is made between the domain and the service using the **bridging-identifier** configuration option. The IEEE and the ITU-T use their own specific formats. The MA short name formats (0-255) have been divided between the IEEE (0-31, 64-255) and the ITU-T (32-63), with five currently defined (1-4, 32). Even though the different standards bodies do not have specific support for the others formats a Y.1731 context can be configured using the IEEE format options.

1 (Primary VID) — Values 0 — 4094

2 (String) — Raw ASCII, excluding 0-31 decimal/0-1F hex (which are control characters) form the ASCII table

3 (2-octet integer) — 0 — 65535

4 (VPN ID) — Hex value as described in RFC 2685, *Virtual Private Networks Identifier*

32 (icc-format) — Exactly 13 characters from the ITU-T recommendation T.50.

**Note:** When a VID is used as the short MA name, 802.1ag will not support VLAN translation because the MA-ID must match all the MEPs. The default format for a short MA name is an

integer. Integer value 0 means the MA is not attached to a VID. This is useful for VPLS services on 7210 SAS platforms because the VID is locally significant.

Maintenance Domain Level (MD Level)/Maintenance Entity Group Level (MEG Level) is the numerical value (0-7) representing the width of the domain. The wider the domain, higher the numerical value, the farther the ETH-CFM packets can travel. It is important to understand that the level establishes the processing boundary for the packets. Strict rules control the flow of ETH-CFM packets and are used to ensure proper handling, forwarding, processing and dropping of these packets. To keep it simple ETH-CFM packets with higher numerical level values will flow through MEPs on MIPs on SAPs configured with lower level values. This allows the operator to implement different areas of responsibility and nest domains within each other. Maintenance association (MA) includes a set of MEPs, each configured with the same MA-ID and MD level used verify the integrity of a single service instance.

Maintenance Endpoint (MEP)/MEG Endpoint (MEP) are the workhorses of ETH-CFM. A MEP is the unique identification within the association (0-8191). Each MEP is uniquely identified by the MA-ID, MEPID tuple. This management entity is responsible for initiating, processing and terminating ETH-CFM functions, following the nesting rules. MEPs form the boundaries which prevent the ETH-CFM packets from flowing beyond the specific scope of responsibility. A MEP has direction, up or down. Each indicates the directions packets will be generated; UP toward the switch fabric, down toward the SAP away from the fabric. Each MEP has an active and passive side. Packets that enter the active point of the MEP will be compared to the existing level and processed accordingly. Packets that enter the passive side of the MEP are passed transparently through the MEP. Each MEP contained within the same maintenance association and with the same level (MA-ID) represents points within a single service. MEP creation on a SAP is allowed only for Ethernet ports with NULL, q-tags, q-in-q encapsulations. MEPs may also be created on SDP bindings.

Maintenance Intermediate Point (MIP)/MEG Intermediate Point (MIP) are management entities between the terminating MEPs along the service path. These provide insight into the service path connecting the MEPs. MIPs only respond to Loopback Messages (LBM) and Linktrace Messages (LTM). All other CFM functions are transparent to these entities. Only one MIP is allowed per SAP or SDP. The creation of the MIPs can be done when the lower level domain is created (explicit). This is controlled by the use of the mhf-creation mode within the association under the bridge-identifier. MIP creation is supported on a SAP and SDP, not including Mesh SDP bindings. By default, no MIPs are created.

---

**NOTE:** The 7210 SAS platforms supports either only Ingress MIPs in some services or bi-directional MIPs (that is, ingress and egress MIPs) in some services. The table below lists the MIP and MEP support for different services on different platforms.

---

There are two locations in the configuration where ETH-CFM is defined. The domains, associations (including linkage to the service id), MIP creation method, common ETH-CFM

functions and remote MEPs are defined under the top level **eth-cfm** command. It is important to note, when Y.1731 functions are required the context under which the MEPs are configured must follow the Y.1731 specific formats (domain format of none, MA format icc-format). Once these parameters have been entered, the MEP and possibly the MIP can be defined within the service under the SAP or SDP.

This is a general table that indicates the ETH-CFM support for the different services and endpoints. It is not meant to indicate the services that are supported or the requirements for those services on the individual platforms.

**Table 6: ETH-CFM Support Matrix for 7210 SAS-M Network Mode**

Service	Ethernet Connection Type	Down MEP	UP MEP	MIP	Primary VLAN
Epipe	SAP	Yes	Yes	Ingress MIP and Egress MIP	Not Supported
	SDP	Yes	Yes	Ingress MIP and Egress MIP	Not Supported
VPLS	SAP	Yes	Yes	Ingress MIP only	Not Supported
	Spoke-SDP	Yes	Yes	Ingress MIP only	Not Supported
	Mesh-SDP	Yes	Yes	Not supported	Not Supported
RVPLS	SAP	Not Supported	Not Supported	Not Supported	Not Supported
IES	IES IPv4 interface	Not Supported	Not Supported	Not Supported	Not Supported
PBB Epipe	I-SAP	Not Supported	Yes	Not Supported	Not Supported
PBB VPLS	I-SAP	Not Supported	Not Supported	Not Supported	Not Supported

Service	Ethernet Connection Type	Down MEP	UP MEP	MIP	Primary VLAN
PBB B-VPLS	B-SAP	Not Supported	Not Supported	Not Supported	Not Supported
IES	SAP	Not Supported	Not Supported	Not Supported	Not Supported
VPRN	SAP	Not Supported	Not Supported	Not Supported	Not Supported

**Table 7: ETH-CFM Support Matrix for 7210 SAS-M Access-Uplink Mode**

Service	Ethernet Connection Type	Down MEP	UP MEP	MIP	Primary VLAN
Epip	SAP (Access and Access-uplink SAP)	Yes	Yes	Ingress MIP and Egress MIP	Not Supported
VPLS	SAP (Access and Access-uplink SAP)	Yes	Yes	Ingress MIP and Egress MIP	Not Supported
RVPLS	SAP	Not Supported	Not Supported	Not Supported	Not Supported
IES	IES IPv4 interface	Not Supported	Not Supported	Not Supported	Not Supported
	SAP	Not Supported	Not Supported	Not supported	Not Supported

**Table 8: ETH-CFM Support Matrix for 7210 SAS-T Access-Uplink Mode**

Service	Ethernet Connection Type	Down MEP	UP MEP	MIP	Primary VLAN
Epipe	SAP (Access and Access-uplink SAP)	Yes	Yes	Ingress MIP and Egress MIP	Not Supported
VPLS	SAP (Access and Access-uplink SAP)	Yes	Yes	Ingress MIP only	Not Supported
RVPLS	SAP	Not Supported	Not Supported	Not Supported	Not Supported
IES	IES IPv4 interface	Not Supported	Not Supported	Not Supported	Not Supported
	SAP	Not Supported	Not Supported	Not supported	Not Supported

**Table 9: ETH-CFM Support Matrix for 7210 SAS-T Network Mode**

Service	Ethernet Connection Type	Down MEP	UP MEP	MIP	Primary VLAN
Epipe	SAP	Yes	Yes	Ingress MIP and Egress MIP	Yes (only on Down MEP)
	SDP	Yes	Yes	Ingress MIP and Egress MIP	Not Supported
VPLS	SAP	Yes	Yes	Ingress MIP only	Yes (only on Down MEP)
	Spoke-SDP	Yes	Yes	Ingress MIP only	Not Supported
	Mesh-SDP	Yes	Yes	Not supported	Not Supported
RVPLS	SAP	Not Supported	Not Supported	Not Supported	Not Supported

Service	Ethernet Connection Type	Down MEP	UP MEP	MIP	Primary VLAN
IES	IES IPv4 interface	Not Supported	Not Supported	Not Supported	Not Supported
PBB Epipe	I-SAP	Not Supported	Yes	Not Supported	Not Supported
PBB VPLS	I-SAP	Not Supported	Not Supported	Not Supported	Not Supported
PBB B-VPLS	B-SAP	Not Supported	Not Supported	Not Supported	Not Supported
IES	SAP	Not Supported	Not Supported	Not Supported	Not Supported
VPRN	SAP	Not Supported	Not Supported	Not Supported	Not Supported

**Table 10: ETH-CFM Support Matrix for 7210 SAS-X devices**

Service	Ethernet Connection Type	Down MEP	UP MEP	MIP	Primary VLAN
Epipe	SAP	Yes	Yes	Ingress MIP and Egress MIP	Yes (only on Down MEP)
	SDP	Yes	Yes	Ingress MIP and Egress MIP	Not Supported
VPLS	SAP	Yes	Yes	Ingress MIP only	Yes (only on Down MEP)
	Spoke-SDP	Yes	Yes	Not Supported	Not Supported
	Mesh-SDP	Yes	Yes	Not supported	Not Supported
RVPLS	SAP	Not Supported	Not Supported	Not Supported	Not Supported

IES	IES IPv4 interface	Not Supported	Not Supported	Not Supported	Not Supported
PBB Epipe	I-SAP	Not Supported	Yes	Not Supported	Not Supported
PBB VPLS	I-SAP	Not Supported	Not Supported	Not Supported	Not Supported
PBB B-VPLS	B-SAP	Not Supported	Not Supported	Not Supported	Not Supported
IES	SAP	Not Supported	Not Supported	Not Supported	Not Supported
VPRN	SAP	Not Supported	Not Supported	Not Supported	Not Supported

**Table 11: ETH-CFM Support Matrix for 7210 SAS-R6 and 7210 SAS-R12 devices**

Service	Ethernet Connection Type	Down MEP	UP MEP	MIP	Primary VLAN
Epipe	SAP	Yes	Yes	Ingress MIP and Egress MIP	Yes (only on Down MEP)
	SDP	Yes	Yes	Ingress MIP and Egress MIP	Not Supported
VPLS	SAP	Yes	Yes (only for IMMv2)	Ingress MIP only for IMMv1 Ingress MIP and Egress MIP for IMMv2	Yes only on IMMv2 (on Down MEP and MIP)
	Spoke-SDP	Yes	Yes (only for IMMv2)	Ingress MIP only	Not Supported
	Mesh-SDP	Not Supported	Yes (only for IMMv2)	Ingress MIP only	Not Supported
RVPLS	SAP	Not Supported	Not Supported	Not Supported	Not Supported
IES	IES IPv4 interface	Not Supported	Not Supported	Not Supported	Not Supported
PBB Epipe	I-SAP	Not Supported	Not Supported	Not Supported	Not Supported
PBB VPLS	I-SAP	Not Supported	Not Supported	Not Supported	Not Supported

PBB B-VPLS	B-SAP	Not Supported	Not Supported	Not Supported	Not Supported
IES	SAP	Not Supported	Not Supported	Not Supported	Not Supported
VPRN	SAP	Not Supported	Not Supported	Not Supported	Not Supported

**Table 12: ETH-CFM Support Matrix for 7210 SAS-Mxp devices**

<b>Service</b>	<b>Ethernet Connection Type</b>	<b>Down MEP</b>	<b>UP MEP</b>	<b>MIP</b>
Epipe	SAP	Yes	Yes	Ingress MIP and Egress MIP
	SDP	Yes	Yes	Ingress MIP and Egress MIP
VPLS	SAP	Yes	Yes	Ingress MIP
	Spoke-SDP	Yes	Yes	Ingress MIP
	Mesh-SDP	Yes	Yes	Not Supported
RVPLS	SAP	Not Supported	Not Supported	Not Supported
IES	IES IPv4 interface	Not Supported	Not Supported	Not Supported
PBB Epipe	I-SAP	Not Supported	Not Supported	Not Supported
PBB VPLS	I-SAP	Not Supported	Not Supported	Not Supported
PBB B-VPLS	B-SAP	Not Supported	Not Supported	Not Supported
IES	SAP	Not Supported	Not Supported	Not Supported
VPRN	SAP	Not Supported	Not Supported	Not Supported

**NOTES:**

- Ethernet-Rings are not configurable under all service types. Any service restrictions for MEP direction or MIP support will override the generic capability of the Ethernet-Ring MPs. For more information on Ethernet-Rings, refer to the 7210 SAS Interfaces Guide.
  - On 7210 platforms in some services only ingress MIP functionality is supported. An ingress MIP or a Down MIP processes messages in the ingress direction when the OAM message is received on ingress of the SAP/Port (subject to the other checks). An egress MIP or an UP MIP refers to a MIP that processes message in the egress direction when the OAM message is being sent out of the SAP/port. For more information for service entities support ingress MIP or egress MIP or both, see the tables above.
  - On 7210 SAS devices, when two bidirectional MIPs are configured in an Epipe service on both the service entities/endpoints (For example: on both the SAP and the SDP configured in the Epipe service), only the MIP ingressing to the direction of linktrace messages responds. This is applicable to 7210 SAS platforms that support both ingress and egress MIPs (also referred to as Bi-directional MIPs).
-

### Configuration Notes on CCM timer support

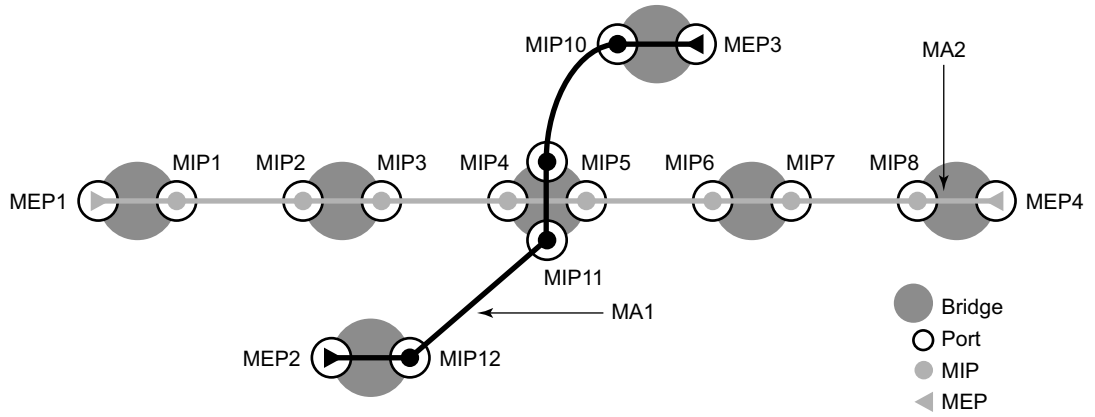

**Figure 10: MEP and MIP**

[Figure 11](#) shows the detailed IEEE representation of MEPs, MIPs, levels and associations, using the standards defined icons.

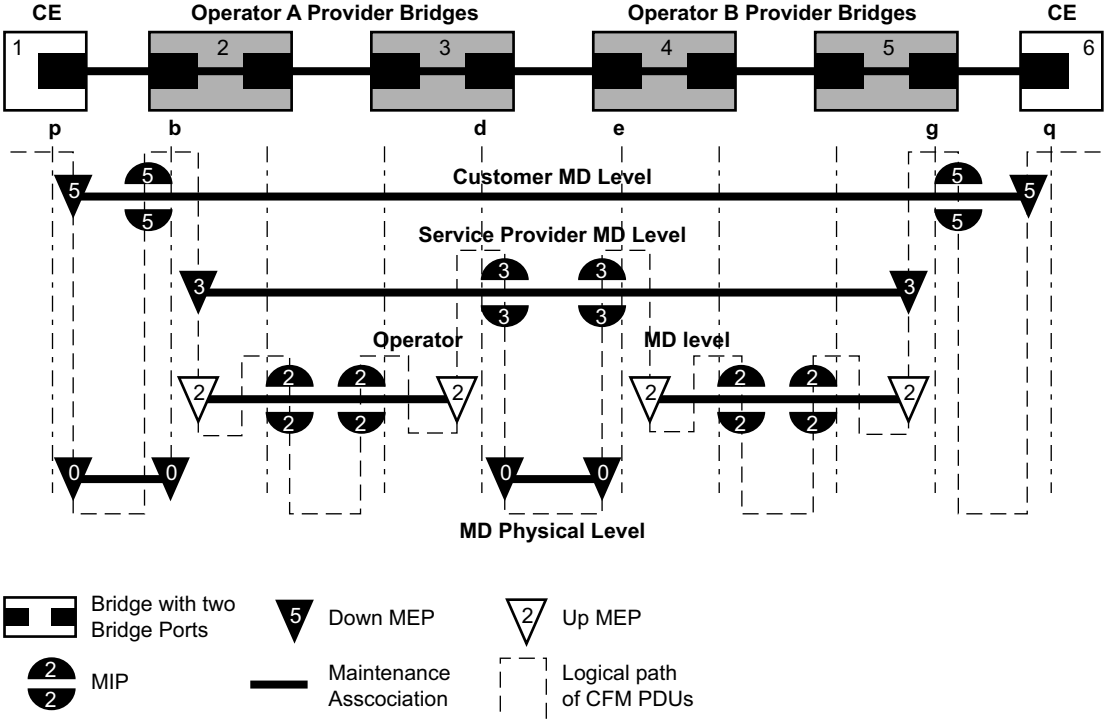
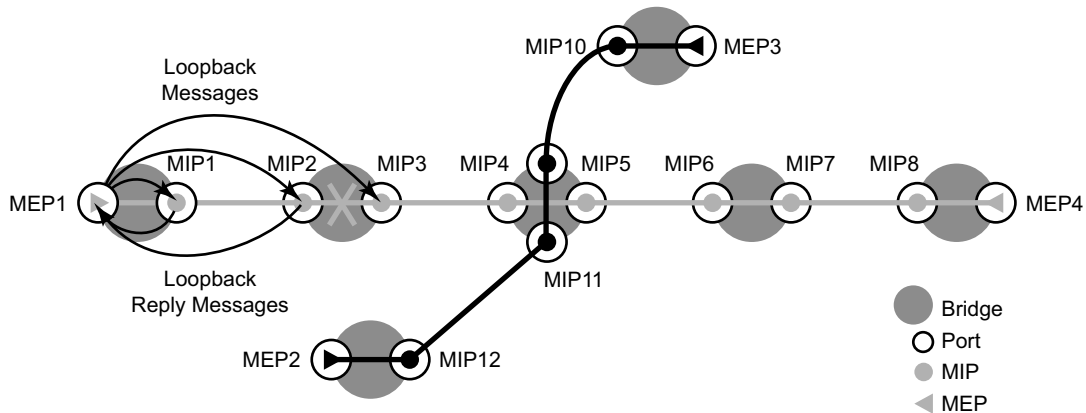

Figure 11: MEP, MIP and MD Levels

## Loopback

A loopback message is generated by an MEP to its peer MEP (Figure 12). The functions are similar to an IP ping to verify Ethernet connectivity between the nodes.



**Figure 12: CFM Loopback**

The following loopback-related functions are supported:

- Loopback message functionality on an MEP or MIP can be enabled or disabled.
- MEP — Supports generating loopback messages and responding to loopback messages with loopback reply messages.
- MIP — Supports responding to loopback messages with loopback reply messages when loopback messages are targeted to self.
- Displays the loopback test results on the originating MEP. There is a limit of ten outstanding tests per node.

## Linktrace

A linktrace message is originated by an MEP and targeted to a peer MEP in the same MA and within the same MD level (Figure 13). Its function is similar to IP traceroute. Traces a specific MAC address through the service. The peer MEP responds with a linktrace reply message after successful inspection of the linktrace message. The MIPs along the path also process the linktrace message and respond with linktrace replies to the originating MEP if the received linktrace message that has a TTL greater than 1 and forward the linktrace message if a look up of the target MAC address in the Layer 2 FIB is successful. The originating MEP shall expect to receive multiple linktrace replies and from processing the linktrace replies, it can put together the route to the target bridge.

A traced MAC address is carried in the payload of the linktrace message, the target MAC. Each MIP and MEP receiving the linktrace message checks whether it has learned the target MAC address. In order to use linktrace the target MAC address must have been learned by the nodes in the network. If so, a linktrace message is sent back to the originating MEP. Also, a MIP forwards the linktrace message out of the port where the target MAC address was learned.

The linktrace message itself has a multicast destination address. On a broadcast LAN, it can be received by multiple nodes connected to that LAN. But, at most, one node will send a reply.

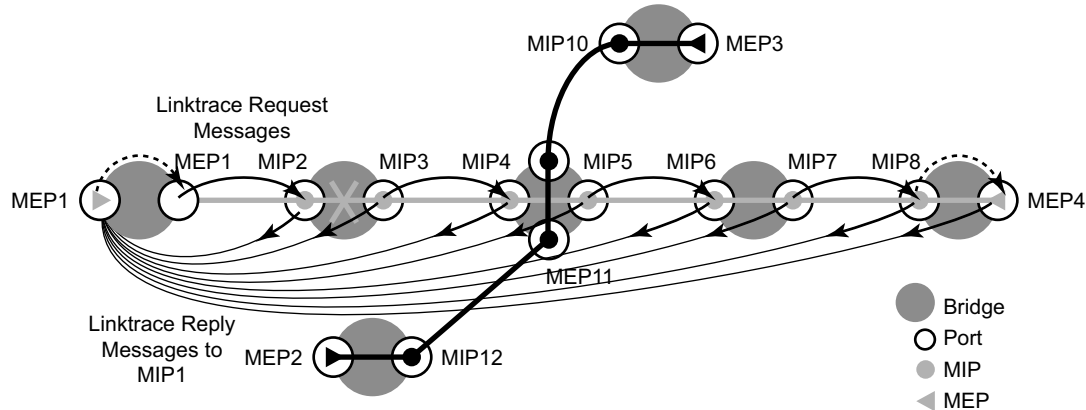

Fig\_13

**Figure 13: CFM Linktrace**

The following linktrace related functions are supported:

- Enable or disables linktrace functions on an MEP.

- MEP — Supports generating linktrace messages and responding with linktrace reply messages.
- MIP — Supports responding to linktrace messages with linktrace reply messages when encoded TTL is greater than 1, and forward the linktrace messages accordingly if a lookup of the target MAC address in the Layer 2 FIB is successful.
- Displays linktrace test results on the originating MEP. There is a limit of ten outstanding tests per node. Storage is provided for upto ten MEPs and for the last ten responses. If more than ten responses are received older entries will be overwritten.

## Continuity Check (CC)

A Continuity Check Message (CCM) is a multicast frame that is generated by a MEP and multicast to all other MEPs in the same MA. The CCM does not require a reply message. To identify faults, the receiving MEP maintains an internal list of remote MEPs it should be receiving CCM messages from.

This list is based off of the remote-mepid configuration within the association the MEP is created in. When the local MEP does not receive a CCM from one of the configured remote MEPs within a pre-configured period, the local MEP raises an alarm.

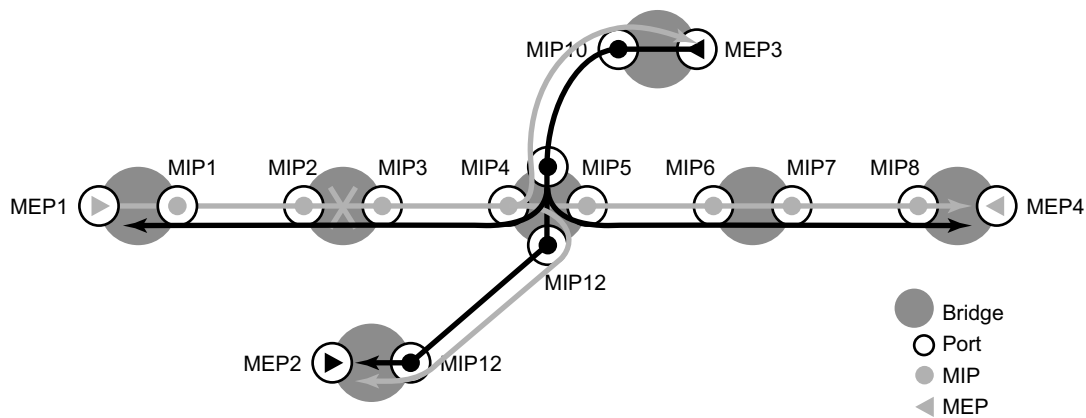

Figure 14: CFM Continuity Check

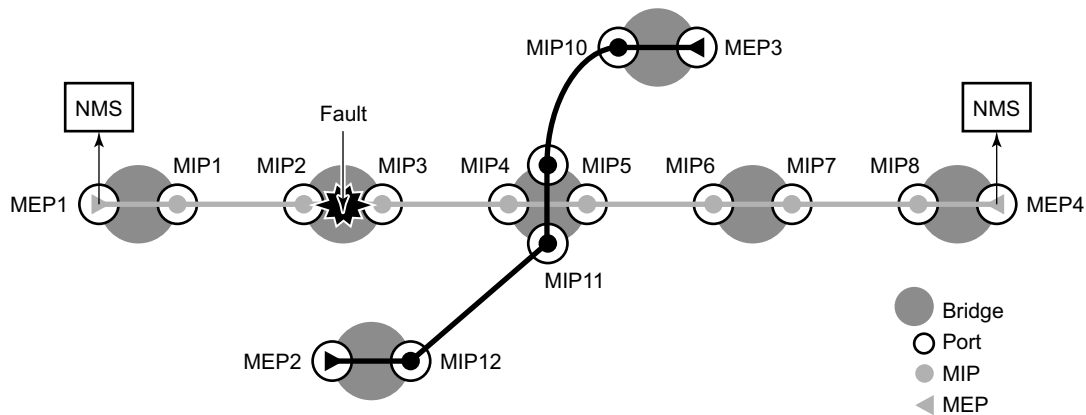

Figure 15: CFM CC Failure Scenario

The following functions are supported:

- Enable and disable CC for an MEP
- Configure and delete the MEP entries in the CC MEP monitoring database manually. It is only required to provision remote MEPs. Local MEPs shall be automatically put into the database when they are created.
- CCM transmit interval: 100ms (Supported only on 7210 SAS-M, 7210 SAS-T, and 7210 SAS-Mxp devices), 1s, 10s, 60s and 600s. Default: 10s. .

When configuring MEPs with sub-second CCM intervals bandwidth consumption must be taken into consideration. Each CCM PDU is 100 bytes (800 bits). Taken individually this is a small value. However, the bandwidth consumption increases rapidly as multiple MEPs are configured with 10ms timers, 100 packets per second. Sub-second enabled MEPs are supported on the following:

- Down MEPs configured on Ethernet SAPs.
- 210 SAS-M can have sub-second CCM configured on SDP.
- Lowest MD-level, when multiple MEPs exist on same Ethernet SAP.
- 7210 SAS-M can have multiple MEPs with sub-second intervals on the same SAP.
- CCM will declare a fault, when:
  - The CCM stops hearing from one of the remote MEPs for 3.5 times CC interval
  - Hears from a MEP with a LOWER MD level
  - Hears from a MEP that is not part of the local MEPs MA
  - Hears from a MEP that is in the same MA but not in the configured MEP list
  - Hears from a MEP in the same MA with the same MEP id as the receiving MEP
  - The CC interval of the remote MEP does not match the local configured CC interval
  - The remote MEP is declaring a fault
- An alarm is raised and a trap is sent if the defect is greater than or equal to the configured low-priority-defect value.
- Remote Defect Indication (RDI) is supported but by default is not recognized as a defect condition because the low-priority-defect setting default does not include RDI.

## Alarm Indication Signal (ETH-AIS Y.1731)

Alarm Indication Signal (AIS) provides an Y.1731 capable MEP the ability to signal a fault condition in the reverse direction of the MEP, out the passive side. When a fault condition is detected the MEP will generate AIS packets at the configured client levels and at the specified AIS interval until the condition is cleared. Currently a MEP configured to generate AIS must do so at a level higher than its own. The MEP configured on the service receiving the AIS packets is required to have the active side facing the receipt of the AIS packet and must be at the same level the AIS, The absence of an AIS packet for 3.5 times the AIS interval set by the sending node will clear the condition on the receiving MEP.

It is important to note that AIS generation is not supported to an explicitly configured endpoint. An explicitly configured endpoint is an object that contains multiple individual endpoints, as in PW redundancy.

---

## Test (ETH-TST Y.1731)

Ethernet test affords operators an Y.1731 capable MEP the ability to send an in service on demand function to test connectivity between two MEPs. The test is generated on the local MEP and the results are verified on the destination MEP. Any ETH-TST packet generated that exceeds the MTU will be silently dropped by the lower level processing of the node.

## Y.1731 Time Stamp Capability

Accurate results for one-way and two-way delay measurement tests using Y.1731 messages are obtained if the nodes are capable of time stamping packets in hardware.

- The 7210 SAS-M and 7210 SAS-X support is as follows:
  - Y.1731 2-DM messages for both Down MEPs and UP MEPs, 1-DM for both Down MEPs and UP MEPs, and 2-SLM for both Down MEPs and UP MEPs use software based timestamps on Tx and hardware based timestamp on Rx. It uses the system clock (free-running or synchronized to NTP) to obtain the timestamps.
  - Y.1731 2-DM messages for both Down MEPs and UP MEPs, 1-DM for both Down MEPs and UP MEPs, and 2-SLM for both Down MEPs and UP MEPs use software based timestamps on Tx and hardware based timestamp on Rx. It uses the system clock (free-running or synchronized to NTP) to obtain the timestamps.

- The 7210 SAS-T (network mode), 7210 SAS-R6 and 7210 SAS-R12 support is as follows:
  - Y.1731 2-DM messages for both Down MEPs and UP MEPs, 1-DM for both Down MEPs and UP MEPs, and 2-SLM for both Down MEPs and UP MEPs use software based timestamps on Tx and hardware based timestamp on Rx. The timestamps are obtained as given below:
    - From NTP, when NTP is enabled and PTP is disabled
    - From PTP, when PTP is enabled (irrespective of whether NTP is disabled or enabled)
    - From free-running system time, when both NTP and PTP are disabled.
- The 7210 SAS-Mxp support is as follows:
  - Y.1731 2-DM messages for both Down MEPs and UP MEPs, 1-DM for both Down MEPs and UP MEPs, and 2-SLM for both Down MEPs and UP MEPs use software based timestamps on Tx and hardware based timestamp on Rx. The timestamps are obtained as given below:
    - From NTP, when NTP is enabled
    - From free-running system time, when NTP is disabled
- The 7210 SAS-T (access-uplink mode) support is as follows:
  - Y.1731 2-DM messages for Down MEPs uses hardware timestamps for both Rx (packets received by the node) and Tx (packets sent out of the node). The timestamps is obtained from a free-running hardware clock. It provides accurate 2-way delay measurements and it is not recommended to use it for computing 1-way delay.
  - Y.1731 2-DM messages for UP MEPs, 1-DM for both Down MEPs and UP MEPs, and 2-SLM for both Down MEPs and UP MEPs use software based timestamps on Tx and hardware based timestamp on Rx. The timestamps are obtained as given below:
    - From NTP, when NTP is enabled and PTP is disabled
    - From PTP, when PTP is enabled (irrespective of whether NTP is disabled or enabled)
    - From free-running system time, when both NTP and PTP are disabled.

**NOTE:** After PTP is enabled once, if the user needs to go back to NTP time scale, or system free-run time scale, a node reboot is required.

---



## Synthetic Loss Measurement (ETH-SL)

Alcatel-Lucent applied pre-standard OpCodes 53 (Synthetic Loss Reply) and 54 (Synthetic Loss Message) for the purpose of measuring loss using synthetic packets.

Notes: These will be changes to the assigned standard values in a future release. This means that the Release 4.0R6 is pre-standard and will not interoperate with future releases of SLM or SLR that supports the standard OpCode values.

This synthetic loss measurement approach is a single-ended feature that allows the operator to run on-demand and proactive tests to determine “in”, “out” loss and “unacknowledged” packets. This approach can be used between peer MEPs in both point to point and multipoint services. Only remote MEP peers within the association and matching the unicast destination will respond to the SLM packet.

The specification uses various sequence numbers in order to determine in which direction the loss occurred. Alcatel-Lucent has implemented the required counters to determine loss in each direction. In order to properly use the information that is gathered the following terms are defined;

- Count — The number of probes that are sent when the last frame is not lost. When the last frame(s) is or are lost, the count and unacknowledged equals the number of probes sent.
- Out-Loss (Far-end) — Packets lost on the way to the remote node, from test initiator to the test destination.
- In-Loss (Near-end) — Packet loss on the way back from the remote node to the test initiator.
- Unacknowledged — Number of packets at the end of the test that were not responded to.

The per probe specific loss indicators are available when looking at the on-demand test runs, or the individual probe information stored in the MIB. When tests are scheduled by Service Assurance Application (SAA) the per probe data is summarized and per probe information is not maintained. Any “unacknowledged” packets will be recorded as “in-loss” when summarized.

The on-demand function can be executed from CLI or SNMP. The on demand tests are meant to provide the carrier a way to perform on the spot testing. However, this approach is not meant as a method for storing archived data for later processing. The probe count for on demand SLM has a range of one to 100 with configurable probe spacing between one second and ten seconds. This means it is possible that a single test run can be up to 1000 seconds in length. Although possible, it is more likely the majority of on demand case can increase to 100 probes or less at a one second interval. A node may only initiate and maintain a single active on demand SLM test at any given time. A maximum of one storage entry per remote MEP is maintained in the results table. Subsequent runs to the same peer can overwrite the results for that peer. This means, when using on demand testing the test should be run and the results checked prior to starting another test.

The proactive measurement functions are linked to SAA. This backend provides the scheduling, storage and summarization capabilities. Scheduling may be either continuous or periodic. It also

allows for the interpretation and representation of data that may enhance the specification. As an example, an optional TVL has been included to allow for the measurement of both loss and delay or jitter with a single test. The implementation does not cause any interoperability because the optional TVL is ignored by equipment that does not support this. In mixed vendor environments loss measurement continues to be tracked but delay and jitter can only report round trip times. It is important to point out that the round trip times in this mixed vendor environments include the remote nodes processing time because only two time stamps will be included in the packet. In an environment where both nodes support the optional TLV to include time stamps unidirectional and round trip times is reported. Since all four time stamps are included in the packet the round trip time in this case does not include remote node processing time. Of course, those operators that wish to run delay measurement and loss measurement at different frequencies are free to run both ETH-SL and ETH-DM functions. ETH-SL is not replacing ETH-DM. Service Assurance is only briefly discussed here to provide some background on the basic functionality. To know more about SAA functions see [Service Assurance Agent Overview on page 145](#).

The ETH-SL packet format contains a test-id that is internally generated and not configurable. The test-id is visible for the on demand test in the display summary. It is possible for a remote node processing the SLM frames receives overlapping test-ids as a result of multiple MEPs measuring loss between the same remote MEP. For this reason, the uniqueness of the test is based on remote MEP-ID, test-id and Source MAC of the packet.

ETH-SL is applicable to up and down MEPs and as per the recommendation transparent to MIPs. There is no coordination between various fault conditions that could impact loss measurement. This is also true for conditions where MEPs are placed in shutdown state as a result of linkage to a redundancy scheme like MC-LAG. Loss measurement is based on the ETH-SL and not coordinated across different functional aspects on the network element. ETH-SL is supported on service based MEPs.

It is possible that two MEPs may be configured with the same MAC on different remote nodes. This causes various issues in the FDB for multipoint services and is considered a misconfiguration for most services. It is possible to have a valid configuration where multiple MEPs on the same remote node have the same MAC. In fact, this is likely to happen. In this release, only the first responder is used to measure packet loss. The second responder is dropped. Since the same MAC for multiple MEPs is only truly valid on the same remote node this should be an acceptable approach

There is no way for the responding node to understand when a test is completed. For this reason a configurable “inactivity-timer” determines the length of time a test is valid. The timer will maintain an active test as long as it is receiving packets for that specific test, defined by the test-id, remote MEP Id and source MAC. When there is a gap between the packets that exceeds the inactivity-timer the responding node responds with a sequence number of one regardless of what the sequence number was the instantiating node sent. This means the remote MEP accepts that the previous test has expired and these probes are part of a new test. The default for the inactivity timer is 100 second and has a range of 10 to 100 seconds.

## Synthetic Loss Measurement (ETH-SL)

The responding node is limited to a fixed number of SLM tests per platform. Any test that attempts to involve a node that is already actively processing more than the system limit of the SLM tests shows up as “out loss” or “unacknowledged” packets on the node that instantiated the test because the packets are silently discarded at the responder. It is important for the operator to understand this is silent and no log entries or alarms is raised. It is also important to keep in mind that these packets are ETH-CFM based and the different platforms stated receive rate for ETH-CFM must not be exceeded. ETH-SL provides a mechanism for operators to pro-actively trend packet loss for service based MEPs.

## Configuration Example

The following illustration, shows the configuration required for proactive SLM test using SAA.

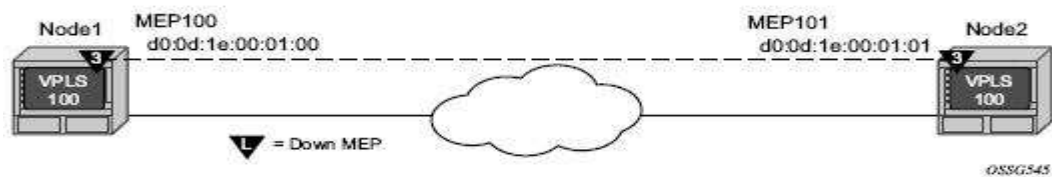

Figure 16: SLM Example

The output from the MIB is shown below as an example of an on-demand test. Node1 is tested for this example. The SAA configuration does not include the accounting policy required to collect the statistics before they are overwritten. NODE2 does not have an SAA configuration. NODE2 includes the configuration to build the MEP in the VPLS service context.

```
config>eth-cfm# info
-----
      domain 3 format none level 3
        association 1 format icc-based name "03-0000000100"
          bridge-identifier 100
          exit
          ccm-interval 1
          remote-mepid 101
        exit
      exit
-----
*A:7210SAS>config>service>vpls# info
-----
      stp
        shutdown
```

```

exit
sap 1/1/3:100.100 create
exit
sap lag-1:100.100 create
  eth-cfm
    mep 100 domain 3 association 1 direction down
    ccm-enable
    mac-address d0:0d:1e:00:01:00
    no shutdown
  exit
exit
no shutdown
-----
*A:7210SAS>config>service>vpls

*A:7210SAS>config>saa# info detail
-----
test "SLM" owner "TiMOS CLI"
  no description
  type
    eth-cfm-two-way-slm 00:01:22:22:33:34 mep 1 domain 1 association 1 size 0
fc "nc" count 100 timeout 1 interval 1
  exit
  trap-gen
    no probe-fail-enable
    probe-fail-threshold 1
    no test-completion-enable
    no test-fail-enable
    test-fail-threshold 1
  exit
  continuous
  no shutdown
  exit
-----

```

```

*A:7210SAS>config>saa#

```

The following sample output is meant to demonstrate the different loss conditions that an operator may see. The total number of attempts is "100" is because the final probe in the test was not acknowledged.

```

*A:7210SAS# show saa SLM42

```

```

=====
SAA Test Information
=====
Test name           : SLM42
Owner name          : TiMOS CLI
Description         : N/A
Accounting policy   : None
Continuous         : Yes
Administrative status : Enabled
Test type          : eth-cfm-two-way-slm 00:25:ba:02:a6:50 mep 4
                   : domain 1 association 1 fc "h1" count 100
                   : timeout 1 interval 1
Trap generation     : None
Test runs since last clear : 117
Number of failed test runs : 1
Last test result    : Success

```

## Synthetic Loss Measurement (ETH-SL)

```

-----
Threshold
Type          Direction Threshold Value      Last Event  Run #
-----
Jitter-in    Rising      None      None      Never      None
              Falling      None      None      Never      None
Jitter-out    Rising      None      None      Never      None
              Falling      None      None      Never      None
Jitter-rt     Rising      None      None      Never      None
              Falling      None      None      Never      None
Latency-in    Rising      None      None      Never      None
              Falling      None      None      Never      None
Latency-out   Rising      None      None      Never      None
              Falling      None      None      Never      None
Latency-rt    Rising      None      None      Never      None
              Falling      None      None      Never      None
Loss-in       Rising      None      None      Never      None
              Falling      None      None      Never      None
Loss-out      Rising      None      None      Never      None
              Falling      None      None      Never      None
Loss-rt       Rising      None      None      Never      None
              Falling      None      None      Never      None
-----

```

```

-----
Test Run: 116
Total number of attempts: 100
Number of requests that failed to be sent out: 0
Number of responses that were received: 100
Number of requests that did not receive any response: 0
Total number of failures: 0, Percentage: 0
(in ms)           Min           Max           Average       Jitter
Outbound  :       8.07         8.18         8.10         0.014
Inbound   :      -7.84        -5.46        -7.77         0.016
Roundtrip :       0.245         2.65         0.334         0.025
Per test packet:
  Sequence  Outbound  Inbound  RoundTrip  Result
          1       8.12     -7.82     0.306  Response Received
          2       8.09     -7.81     0.272  Response Received
          3       8.08     -7.81     0.266  Response Received
          4       8.09     -7.82     0.270  Response Received
          5       8.10     -7.82     0.286  Response Received
          6       8.09     -7.81     0.275  Response Received
          7       8.09     -7.81     0.271  Response Received
          8       8.09     -7.82     0.277  Response Received
          9       8.11     -7.81     0.293  Response Received
         10       8.10     -7.82     0.280  Response Received
         11       8.11     -7.82     0.293  Response Received
         12       8.10     -7.82     0.287  Response Received
         13       8.10     -7.82     0.286  Response Received
         14       8.09     -7.82     0.276  Response Received
         15       8.10     -7.82     0.284  Response Received
         16       8.09     -7.82     0.271  Response Received
         17       8.11     -7.81     0.292  Response Received
-----

```

The following is an example of an on demand tests that and the associated output. Only single test runs are stored and can be viewed after the fact.

```

#oam eth-cfm two-way-slm-test 00:25:ba:04:39:0c mep 4 domain 1 association 1 send-count
10 interval 1 timeout 1
Sending 10 packets to 00:25:ba:04:39:0c from MEP 4/1/1 (Test-id: 143

```

Sent 10 packets, 10 packets received from MEP ID 3, (Test-id: 143)  
(0 out-loss, 0 in-loss, 0 unacknowledged)

\*A:7210SAS>show# eth-cfm mep 4 domain 1 association 1 two-way-slm-test

```
=====
Eth CFM Two-way SLM Test Result Table (Test-id: 143)
=====
Peer Mac Addr      Remote MEP      Count      In Loss      Out Loss      Unack
-----
00:25:ba:04:39:0c      3              10         0            0            0
=====
*A:7210SAS>show#
```

## ETH-CFM QoS Considerations

UP MEPs and Down MEPs have been aligned as of this release to better emulate service data. When an UP MEP or DOWN MEP is the source of the ETH-CFM PDU the priority value configured, as part of the configuration of the MEP or specific test, will be treated as the Forwarding Class (FC) by the egress QoS policy. If there is no egress QoS policy the priority value will be mapped to the CoS values in the frame. However, egress QoS Policy may overwrite this original value. The Service Assurance Agent (SAA) uses [fc {fc-name}] to accomplish similar functionality.

UP MEPs and DOWN MEPs terminating an ETH-CFM PDU will use the received FC as the return priority for the appropriate response, again feeding into the egress QoS policy as the FC.

ETH-CFM PDUs received on the MPLS-SDP bindings will now properly pass the EXP bit values to the ETH-CFM application to be used in the response.

These are default behavioral changes without CLI options.

---

### Configuration guidelines

- On 7210 SAS platforms Ethernet Linktrace Response (ETH-LTR) is always sent out with priority 7.
- 7210 SAS platforms, send out all CFM packets as in-profile. Currently, there is no mechanism in the SAA tools to specify the profile of the packet.
- On 7210 SAS-M only UP MEPs behavior has been modified. Down MEPs are not supported.
- Other than as noted above, this behavior is applicable to all 7210 platforms where the feature supported has been added in both access-uplink mode and network mode of operation. Please see the Release Notes to know which platform and MEPs/MIPs support this feature.

## OAM Mapping

---

OAM mapping is a mechanism that enables a way of deploying OAM end-to-end in a network where different OAM tools are used in different segments. For instance, an Epipe service could span across the network using Ethernet access (CFM used for OAM), pseudowire (T-LDP status signaling used for OAM), and Ethernet access (CFM used for OAM).

In the 7210 SAS implementation, the Service Manager (SMGR) is used as the central point of OAM mapping. It receives and processes the events from different OAM components, then decides the actions to take, including triggering OAM events to remote peers.

Fault propagation for CFM is by default disabled at the MEP level to maintain backward compatibility. When required, it can be explicitly enabled by configuration.

Fault propagation for a MEP can only be enabled when the MA is comprised of no more than two MEPs (point-to-point).

---

## CFM Connectivity Fault Conditions

CFM MEP declares a connectivity fault when its defect flag is equal to or higher than its configured lowest defect priority. The defect can be any of the following depending on configuration:

- DefRDICCM
- DefMACstatus
- DefRemoteCCM
- DefErrorCCM
- DefXconCCM

The following additional fault condition applies to Y.1731 MEPs:

- Reception of AIS for the local MEP level

Setting the lowest defect priority to allDef may cause problems when fault propagation is enabled in the MEP. In this scenario, when MEP A sends CCM to MEP B with interface status down, MEP B will respond with a CCM with RDI set. If MEP A is configured to accept RDI as a fault, then it gets into a dead lock state, where both MEPs will declare fault and never be able to recover. The default lowest defect priority is DefMACstatus, which will not be a problem when interface status TLV is used. It is also very important that different Ethernet OAM strategies should not overlap the span of each other. In some cases, independent functions attempting to perform their normal fault handling can negatively impact the other. This interaction can lead to fault propagation in the

direction toward the original fault, a false positive, or worse, a deadlock condition that may require the operator to modify the configuration to escape the condition. For example, overlapping Link Loss Forwarding (LLF) and ETH-CFM fault propagation could cause these issues.

For the DefRemoteCCM fault, it is raised when any remote MEP is down. So whenever a remote MEP fails and fault propagation is enabled, a fault is propagated to SMGR.

---

## CFM Fault Propagation Methods

When CFM is the OAM module at the other end, it is required to use any of the following methods (depending on local configuration) to notify the remote peer:

- Generating AIS for certain MEP levels
  - Sending CCM with interface status TLV “down”
  - Stopping CCM transmission
- 

**NOTE:** 7210 platforms expect that the fault notified using interface status TLV, is cleared explicitly by the remote MEP when the fault is no longer present on the remote node. On 7210 SAS-M, use of CCM with interface status TLV Down is not recommended to be configured with a Down MEP, unless it is known that the remote MEP clears the fault explicitly.

User can configure UP MEPs to use Interface Status TLV with fault propagation. Special considerations apply only to Down MEPs.

---

When a fault is propagated by the service manager, if AIS is enabled on the SAP/SDP-binding, then AIS messages are generated for all the MEPs configured on the SAP/SDP-binding using the configured levels.

Note that the existing AIS procedure still applies even when fault propagation is disabled for the service or the MEP. For example, when a MEP loses connectivity to a configured remote MEP, it generates AIS if it is enabled. The new procedure that is defined in this document introduces a new fault condition for AIS generation, fault propagated from SMGR, that is used when fault propagation is enabled for the service and the MEP.

The transmission of CCM with interface status TLV must be done instantly without waiting for the next CCM transmit interval. This rule applies to CFM fault notification for all services.

Notifications from SMGR to the CFM MEPs for fault propagation should include a direction for the propagation (up or down: up means in the direction of coming into the SAP/SDP-binding; down means in the direction of going out of the SAP/SDP-binding), so that the MEP knows what method to use. For instance, an up fault propagation notification to a down MEP will trigger an

AIS, while a down fault propagation to the same MEP can trigger a CCM with interface TLV with status down.

For a specific SAP/SDP-binding, CFM and SMGR can only propagate one single fault to each other for each direction (up or down).

When there are multiple MEPs (at different levels) on a single SAP/SDP-binding, the fault reported from CFM to SMGR will be the logical OR of results from all MEPs. Basically, the first fault from any MEP will be reported, and the fault will not be cleared as long as there is a fault in any local MEP on the SAP/SDP-binding.

## Epipse Services

Down and up MEPs are supported for Epipse services as well as fault propagation. When there are both up and down MEPs configured in the same SAP/SDP-binding and both MEPs have fault propagation enabled, a fault detected by one of them will be propagated to the other, which in turn will propagate fault in its own direction.

---

### CFM Detected Fault

When a MEP detects a fault and fault propagation is enabled for the MEP, CFM needs to communicate the fault to SMGR, so SMGR will mark the SAP/SDP-binding faulty but still oper-up. CFM traffic can still be transmitted to or received from the SAP/SDP-binding to ensure when the fault is cleared, the SAP will go back to normal operational state. Since the operational status of the SAP/SDP-binding is not affected by the fault, no fault handling is performed. For example, applications relying on the operational status are not affected.

If the MEP is an up MEP, the fault is propagated to the OAM components on the same SAP/SDP-binding; if the MEP is a down MEP, the fault is propagated to the OAM components on the mate SAP/SDP-binding at the other side of the service.

### SAP/SDP-Binding Failure (Including Pseudowire Status)

When a SAP/SDP-binding becomes faulty (oper-down, admin-down, or pseudowire status faulty), SMGR needs to propagate the fault to up MEP(s) on the same SAP/SDP-bindings about the fault, as well as to OAM components (such as down MEPs) on the mate SAP/SDP-binding.

---

### Service Down

This section describes procedures for the scenario where an Epipse service is down due to the following:

- Service is administratively shutdown. When service is administratively shutdown, the fault is propagated to the SAP/SDP-bindings in the service.
- If the Epipse service is used as a PBB tunnel into a B-VPLS, the Epipse service is also considered operationally down when the B-VPLS service is administratively shutdown or operationally down. If this is the case, fault is propagated to the Epipse SAP.

In addition, one or more SAPs/SDP-bindings in the B-VPLS can be configured to propagate fault to this Epipse (see fault-propagation-bmac below). If the B-VPLS is operationally up but all of these entities have detected fault or are down, the fault is propagated to this Epipse's SAP.

## Interaction with Pseudowire Redundancy

When a fault occurs on the SAP side, the pseudowire status bit is set for both active and standby pseudowires. When only one of the pseudowire is faulty, SMGR does not notify CFM. The notification occurs only when both pseudowire becomes faulty. The SMGR propagates the fault to CFM.

Since there is no fault handling in the pipe service, any CFM fault detected on an SDP binding is not used in the pseudowire redundancy's algorithm to choose the most suitable SDP binding to transmit on.

---

## LLF and CFM Fault Propagation

LLF and CFM fault propagation are mutually exclusive. CLI protection is in place to prevent enabling both LLF and CFM fault propagation in the same service, on the same node and at the same time. However, there are still instances where irresolvable fault loops can occur when the two schemes are deployed within the same service on different nodes. This is not preventable by the CLI. At no time should these two fault propagation schemes be enabled within the same service.

## 802.3ah EFM OAM Mapping and Interaction with Service Manager

802.3ah EFM OAM declares a link fault when any of the following occurs:

- Loss of OAMPDU for a certain period of time
- Receiving OAMPDU with link fault flags from the peer

When 802.3ah EFM OAM declares a fault, the port goes into operation state down. The SMGR communicates the fault to CFM MEPs in the service. OAM fault propagation in the opposite direction (SMGR to EFM OAM) is not supported.

---

## Fault Propagation to access dot1q/QinQ ports in Access-uplink mode

The Fault on the access uplink port brings down all access ports with services independent of the encap type of the access port (NULL or dot1q or QinQ), that is, support Link Loss Forwarding (LLF). The Fault propagated from the access-uplink port to access ports is based on configuration. The Fault is propagated only in a single direction, that is access-uplink port to access port.

The Fault on access-uplink port is detected using LoS and EFM-OAM.

Figure 17: Local Fault Propagation

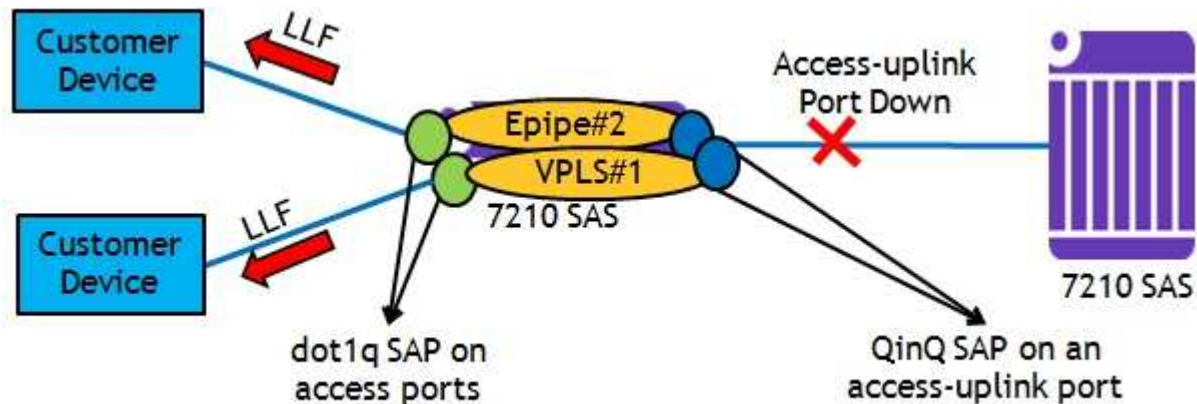

## Configuring Fault propagation:

To allow faults to be detected on access-uplink ports and be propagated to all the other interested access ports irrespective of their encapsulation, the concept of oper-group is used. In 7210, ports can be associated with oper-groups. Following bullets describe the use of oper-group functionality for fault-detection on a port and monitor-oper-group to track the status of the oper-group and propagate fault based on the operational state of the oper-group.

- Create an oper-group (For example: “uplink-to-7210”)
- Configure access-uplink port whose operational state needs to be tracked (For example: 1/1/20) and associate it with the oper-group created above (that is, uplink-to-7210)
- Configure dot1q access ports whose operational state needs to be driven by operational state of access-uplink port (For example: 1/1/1 and 1/1/5), as the monitor-oper-group
- To detect fault on access-uplink port and change the operational state, either Loss of Signal or EFM OAM can be used.
- When the operational state of access-uplink port changes from UP to DOWN changes the state of all access ports configured to monitor the group to “Down”. Similarly, a change in state from Down to UP, changes the operational state of the access port to UP. When the operational state of access port is brought down, the laser of the port is also shutdown. The command "*Hold timers*" are supported to avoid flapping of links.

## Configuration Example for fault propagation using oper-group

The following example displays an “oper-group” system configuration:

```
*A:7210SAS>config>system>oper-group# info detail
```

## OAM Mapping

```
hold-time
  group-down 0
  group-up 4
exit
```

-----  
\*A: 7210SAS>config>system>oper-group#

**Note:** For more details on the CLI, see the “7210 SAS System Basics User Guide”.

---

## Service Assurance Agent Overview

In the last few years, service delivery to customers has drastically changed. Services such as VPLS and VPRN are offered. The introduction of Broadband Service Termination Architecture (BSTA) applications such as Voice over IP (VoIP), TV delivery, video and high speed Internet services force carriers to produce services where the health and quality of Service Level Agreement (SLA) commitments are verifiable to the customer and internally within the carrier.

SAA is a feature that monitors network operations using statistics such as jitter, latency, response time, and packet loss. The information can be used to troubleshoot network problems, problem prevention, and network topology planning.

The results are saved in SNMP tables are queried by either the CLI or a management system. Threshold monitors allow for both rising and falling threshold events to alert the provider if SLA performance statistics deviate from the required parameters.

SAA allows two-way timing for several applications. This provides the carrier and their customers with data to verify that the SLA agreements are being properly enforced.

---

## Traceroute Implementation

The 7210 SAS devices insert the timestamp in software (by control CPU).

When interpreting these timestamps care must be taken that some nodes are not capable of providing timestamps, as such timestamps must be associated with the same IP-address that is being returned to the originator to indicate what hop is being measured.

---

## NTP

Because NTP precision can vary (+/- 1.5ms between nodes even under best case conditions), SAA one-way latency measurements might display negative values, especially when testing network segments with very low latencies. The one-way time measurement relies on the accuracy of NTP between the sending and responding nodes.

## Writing SAA Results to Accounting Files

SAA statistics enables writing statistics to an accounting file. When results are calculated an accounting record is generated.

In order to write the SAA results to an accounting file in a compressed XML format at the termination of every test, the results must be collected, and, in addition to creating the entry in the appropriate MIB table for this SAA test, a record must be generated in the appropriate accounting file.

---

## Accounting File Management

Because the SAA accounting files have a similar role to existing accounting files that are used for billing purposes, existing file management information is leveraged for these accounting (billing) files.

---

## Assigning SAA to an Accounting File ID

Once an accounting file has been created, accounting information can be specified and will be collected by the **config>log>acct-policy>** to file *log-file-id* context.

## Continuous Testing

When you configure a test, use the **config>saa>test>continuous** command to make the test run continuously. Use the **no continuous** command to disable continuous testing and **shutdown** to disable the test completely. Once you have configured a test as continuous, you cannot start or stop it by using the **saa test-name [owner test-owner] {start | stop} [no-accounting]** command.

## Configuring SAA Test Parameters

The following example displays an SAA configuration:

```
*A:Dut-A>config>saa# info
-----
.....
test "Dut-A:1413:1501" owner "TiMOS"
  description "Dut-A:1413:1501"
  type
    vccv-ping 1413:1501 fc "nc" timeout 10 size 200 count 2
  exit
  loss-event rising-threshold 2
  latency-event rising-threshold 100
  no jitter-event
```

```
no shutdown
exit
....
-----
*A:Dut-A#
```

## Y.1564 Testhead OAM tool

**Note:** Port loopback with mac-swap and Y.1564 testhead is supported only for Epipe and VPLS services.

ITU-T Y.1564 defines the out-of-service test methodology to be used and parameters to be measured to test service SLA conformance during service turn up. It primarily defines 2 test phases. The first test phase defines service configuration test, which consists of validating whether the service is configured properly. As part of this test the throughput, Frame Delay, Frame Delay Variation (FDV), and Frame Loss Ratio (FLR) is measured for each service. This test is typically run for a short duration. The second test phase consists of validating the quality of services delivered to the end customer and is referred to as the service performance test. These tests are typically run for a longer duration and all traffic is generated up to the configured CIR for all the services simultaneously and the service performance parameters are measured for each the service.

The 7210 SAS supports service configuration test for user configured rate and measurement of delay, delay variation and frame loss ratio with the testhead OAM tool. 7210 testhead OAM tool supports bi-directional measurement and it can generate test traffic for only one service at a given time. It can validate if the user specified rate is available and compute the delay, delay variation and frame loss ratio for the service under test at the specified rate. It is capable of generating traffic upto 1G rate. On some 7210 SAS devices, the user needs to configure the resources of the front-panel port for use with this feature and some other 7210 SAS platforms resources needed for this feature is automatically allocated by software from the internal ports. For more information, see [Configuration Guidelines on page 155](#), below to which 7210 SAS platforms need user configuration and on which 7210 platforms software allocates it automatically.

[Figure 18](#) illustrates the remote loopback required and the flow of the frame through the network generated by the testhead tool.

**Figure 18: 7210 acting as traffic generator and traffic analyzer**

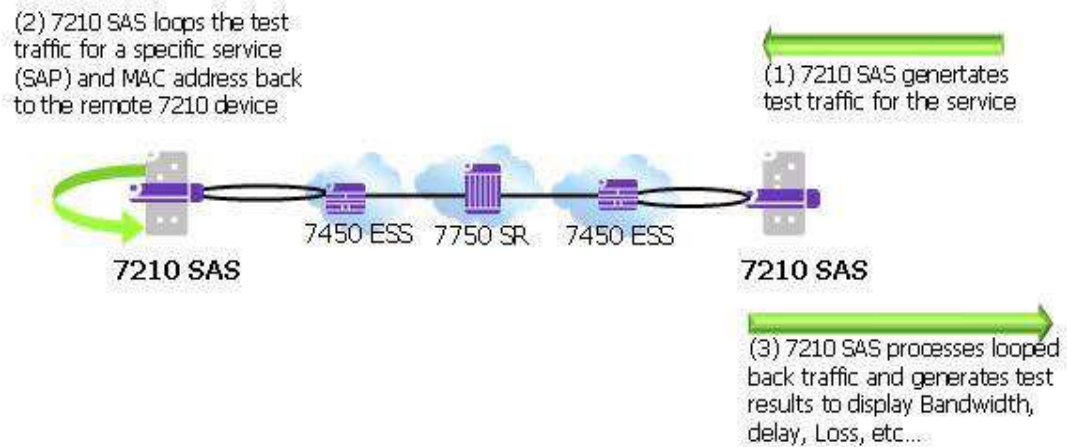

The tool allows the user to specify the frame payload header parameters independent of the test SAP configuration parameters to allow the user flexibility to test for different possible frame header encapsulations. This allows user to specify the appropriate VLAN tags, ethertype, and dot1p's, independent of the SAP configuration like with actual service testing. In other words, the software does not use the parameters (For example: SAP ID, Source MAC, and Destination MAC) during the invocation of the testhead tool to build the test frames. Instead it uses the parameters specified using the frame-payload CLI command tree. The software does not verify that the parameters specified match the service configuration used for testing, for example, software does not match if the VLAN tags specified matches the SAP tags, the ethertype specified matches the user configured port ethertype, and so on. It is expected that the user configures the frame-payload appropriately so that the traffic matches the SAP configuration.

7210 SAS supports Y.1564 testhead for performing CIR or PIR tests in color-aware mode. With this functionality, users can perform service turn-up tests to validate the performance characteristics (delay, jitter, and loss) for committed rate (CIR) and excess rate above CIR (that is, PIR rate). The testhead OAM tool uses the in-profile packet marking value and out-of-profile packet marking value, to differentiate between committed traffic and PIR traffic in excess of CIR traffic. Traffic within CIR (that is, committed traffic) is expected to be treated as in-profile traffic in the network and traffic in excess of CIR (that is, PIR traffic) is expected to be treated as out-of-profile traffic in the network, allowing the network to prioritize committed traffic over PIR traffic. The testhead OAM tool allows the user to configure individual thresholds for green or in-profile packets and out-of-profile or yellow packets. It is used by the testhead OAM tool to compare the measured value for green or in-profile packets and out-of-profile or yellow packets against the configured thresholds and report success or failure.

The following functionality is supported by the testhead OAM tool:

- Supports configuration of only access SAPs as the test measurement point.

- Supports all port encapsulation supported on all svc-sap-types.
- Supported for only VPLS and Epipe service.
- Supports two-way measurement of service performance metrics. The tests must measure throughput, frame delay, frame delay variation, and frame loss ratio.
- For two-way measurement of the service performance metrics, such as frame delay and frame delay variation, test frames (also called as marker packets) are injected at a low rate at periodic intervals. Frame delay and Frame delay variation is computed for these frames. Hardware based timestamps is used for delay computation.
- 7210 SAS supports configuration of PIR rate and provides an option to measure the performance metrics for the frames. The testhead OAM tool, generates traffic upto the specified rate and measures service performance metrics such as, delay, jitter, loss for in-profile, and out-of-profile traffic.
- Testhead tool can generate traffic up to about 1G rate. CIR and PIR rate can be specified by the user and is rounded off the nearest rate the hardware supports by using the adaptation rule configured by the user.
- Allows the user to specify the different frame-sizes from 64 bytes - 9212 bytes.
- User can configure the following frame payload types- L2 payload, IP payload, and IP/TCP/UDP payload. Testhead tool will use the configured values for the IP header fields and TCP header fields based on the payload type configured. User is provided with an option to specify the data pattern to used in the payload field of the frame/packet.
- Allows the user to configure the duration of the test up to a maximum of 24 hours, 60 minutes, and 60 seconds. The test performance measurements by are done after the specified rate is achieved. At any time user can probe the system to know the current status and progress of the test.
- Supports configuration of the Forwarding Class (FC). It is expected that user will define consistent QoS classification policies to map the packet header fields to the FC specified on the test SAP ingress on the local node, in the network on the nodes through which the service transits, and on the SAP ingress in the remote node.
- Allows the user to configure a test-profile, also known as, a policy template that defines the test configuration parameters. User can start a test using a pre-configured test policy for a specific SAP and service. The test profile allows the user to configure the acceptance criteria. The acceptance criteria allows user to configure the thresholds that indicates the acceptable range for the service performance metrics. An event is generated if the test results exceed the configured thresholds. For more information, see the CLI section below. At the end of the test, the measured values for FD, FDV, and FLR are compared against the configured thresholds to determine the PASS or FAIL criteria and to generate a trap to the management station. If the acceptance criteria is not configured, the test result is declared to be PASS, if the throughput is achieved and frame-loss is 0 (zero).

- ITU-T Y.1564 specifies different test procedures as follows. CIR and PIR configuration tests are supported by the testhead tool.
  - CIR and PIR configuration test (color-aware and non-color aware).
  - Traffic policing test (color-aware and non-color aware) is supported. Traffic policing tests can be executed by the user by specifying a PIR to be 125% of the desired PIR. Traffic policing test can be executed in either color-aware mode or color-blind (non-color-aware) mode.
- ITU-T Y.1564 specifies separate test methodology for color-aware and non-color-aware tests. The standard requires a single test to provide the capability to generate both green-color/in-profile traffic for rates within CIR and yellow-color or out-of-profile traffic for rates above CIR and within EIR. The 7210 SAS testhead marks test packets appropriately when generating the traffic, as SAP ingress does not support color-aware metering, it is not possible to support EIR color-aware, and traffic policing color-aware tests end-to-end in a network (that is, from test SAP to test SAP). Instead, It is possible to use the tests to measure the performance parameters from the other endpoint (example Access-uplink SAP) in the service, through the network, to the remote test SAP, and back again to the local test SAP.
- The 7210 SAS Y.1564 testhead is applicable only for VPLS and Epipe services.

## Pre-requisites for using the Testhead Tool

---

### Generic pre-requisites for use of testhead tool (applicable for all 7210 SAS platforms):

- It is expected that the user will configure the appropriate ACL and QoS policies to ensure that the testhead traffic is processed as desired by the local and remote node/SAP. In particular, QoS policies in use must ensure that the rate in use for the SAP ingress meters exceed or are equal to the user configured rate for testhead tests and the classification policies map the testhead packets to the appropriate FCs/queues (the FC classification must match the FC specified in the CLI command testhead-test) using the packet header fields configured in the frame-payload. Similarly, ACL policies must ensure that testhead traffic is not blocked.
- The testhead OAM tool does not check the state of the service or the SAPs on the local endpoint before initiating the tests. The operator must ensure that the service and SAPs used for the test are UP before the tests are started. If they are not, the testhead tool will report a failure.
- The port configuration of the ports used for validation (For example: access port on which the test SAP is configured and access-uplink port) must not be modified after the testhead tool is invoked. Any modifications can be made only when the testhead tool is not running.
- Testhead tool can be used to test only unicast traffic flows. It must not be used to test BUM traffic flows.
- Only out-of-service performance metrics can be measured using testhead OAM tool. For in-service performance metrics, user has the option to use SAA based Y.1731/CFM tools.

This section describes some pre-requisites to use the testhead tool .

- The configuration guidelines and pre-requisites that are to be followed when the port loopback with mac-swap feature is used standalone, applies to its use along with testhead tool. For more information, see the description in the “7210 SAS-M,T, X, R6, R12, Mxp Interfaces User Guide”.
- User must configure resources for ACL MAC criteria in ingress-internal-tcam using the command `config>system> resource-profile> ingress-internal-tcam> acl-sap-ingress> mac-match-enable`. Additionally they must allocate resources to egress ACL MAC or IPv4 or IPv6 64-bit criteria (using the command `config>system> resource-profile> egress-internal-tcam> acl-sap-egress> mac-ipv4-match-enable` or `mac-ipv6-64bit-enable` or `mac-ipv4-match-enable`). Testhead tool uses resources from these resource pools. If no resources are allocated to these pools or no resources are available for use in these pools, then testhead fails to function. Testhead needs a minimum of about 6 entries from the ingress-internal-tcam pool and 2 entries from the egress-internal-tcam pool. If user

allocates resources to egress ACLs IPv6 128-bit match criteria (using the command `config> system> resource-profile> egress-internal-tcam> acl-sap-egress> ipv6-128bit-match-enable`), then testhead fails to function.

- For both Epipe and VPLS service, the test can be used to perform only a point-to-point test between the given source and destination MAC address. Port loopback mac-swap functionality must be used for both Epipe and VPLS services. The configured source and destination MAC address is associated with the two SAPs configured in the service and used as the two endpoints. In other words, the user configured source MAC and destination MAC addresses are used by the testhead tool on the local node to identify the packets as belonging to testhead application and are processed appropriately at the local end and at the remote end these packets are processed by the port loopback with mac-swap application.
- Configure the MACs (source and destination) statically for VPLS service.
- Port loopback must be in use on both the endpoints (that is, the local node, the port on which the test SAP is configured and the remote node, the port on which the remote SAP is configured for both Epipe and VPLS services. Port loopback with mac-swap must be setup by the user on both the local end and the remote end before invoking the testhead tool. These must match appropriately for traffic to flow, else there will be no traffic flow and the testhead tool reports a failure at the end of the completion of the test run.
- Additionally, port loopback with mac-swap must be used at both the ends and if any services/SAPs are configured on the test port, they need to be shutdown to avoid packets being dropped on the non-test SAP. The frames generated by the testhead tool will egress the access SAP and ingress back on the same port, using the resources of the 2 internal loopback ports (one for testhead and another for mac-swap functionality), before being sent out to the network side (typically an access-uplink SAP) to the remote end". At the remote end, it is expected that the frames will egress the SAP under test and ingress back in again through the same port, going through another loopback (with mac-swap) before being sent back to the local node where the testhead application is running.
- The FC specified is used to determine the queue to enqueue the marker packets generated by testhead application on the egress of the test SAP on the local node.
- The use of port loopback is service affecting. It affects all the services configured on the port. It is not recommended to use a SAP, if the port on which they are configured, is used to transport the service packets towards the core. As, a port loopback is required for the testhead to function correctly, doing so might result in loss of connectivity to the node when in-band management is in use. Additionally, all services being transported to the core will be affected.
- It also affects service being delivered on that SAP. Only out-of-service performance metrics can be measured using testhead OAM tool. For in-service performance metrics, user has the option to use SAA based Y.1731/CFM tools.
- Testhead tool uses marker packets with special header values. The QoS policies and ACL policies need to ensure that same treatment as accorded to testhead traffic is given to marker packets. Marker packets are IPv4 packet with IP option set and IP protocol set to

252. It uses the src and dst MAC addresses, Dot1p, IP ToS, IP DSCP, IP TTL, IP source address and destination address as configured in the frame-payload. It does not use the IP protocol and TCP/UDP port numbers from the frame-payload configured. If the payload-type is “12”, IP addresses are set to 0.0.0.0, IP TTL is set to 0, IP TOS is set to 0 and DSCP is set to be, if these values are not explicitly configured in the frame-payload. Ethertype configured in the frame-payload is not used for marker packets, it is always set to ethertype = 0x0800 (ethertype for IPv4) as marker packets are IPv4 packets. QoS policies applied in the network needs to be configured such that the classification for marker packets is similar to service packets. An easy way to do this is by using the header fields that are common across marker packets and service packets, such as MAC (src and dst) addresses, VLAN ID, Dot1p, IPv4 (src and dst) addresses, IP DSCP, and IP ToS. Use of other fields which are different for marker packets and service packets is not recommended. ACL policies in the network must ensure that marker packets are not dropped.

- The mac-swap loopback port, the testhead loopback port and the uplink port must not be modified after the testhead tool is invoked. Any modifications can be made only when the testhead tool is not running.
  - Link-level protocols (For example: LLDP, EFM, and other protocols) must not be enabled on the port on which the test SAP is configured. In general, no other traffic must be sent out of the test SAP when the testhead tool is running.
  - The frame payload must be configured such that number of tags match the number of SAP tags. For example: For 0.\* SAP, the frame payload must be untagged or priority tagged and it cannot contain another tag following the priority tag.
-

## Configuration Guidelines

This section provide the configuration guidelines for this feature (that is, testhead OAM tool). It is applicable to all the platforms discussed in this guide unless a specific platform is called out explicitly.

- SAPs configured on LAG cannot be configured for testing with testhead tool. Other than the test SAP, other service endpoints (For example: SAPs/SDP-Bindings) configured in the service can be over a LAG.
- The user needs to configure the resources of another port for use with the testhead OAM tool. The user can configure the resources of the internal virtual ports (if available) or configure the resources of a front-panel port for use with testhead OAM tool. Please read the details provided in the CLI command `config> system> loopback-no-svc-port` in the 7210 SAS Interfaces user guide to know if front-panel port resources are needed and use the command `show>system>internal-loopback-ports [detail]` to know if internal port resources are available in use by other applications. The port configured for testhead tool use cannot be shared with other applications that need the loopback port. The resources of the loopback port are used by the testhead tool for traffic generation.  
**NOTE:** On 7210 SAS-R6 and 7210 SAS-R12, the ports allocated for testhead OAM tool, the mac-swap OAM tool and the test SAP must be on the same line card and cannot be on different line cards.
- Port loopback with mac-swap is used at both ends and all services on the port on which the test SAP is configured and SAPs in the VPLS service, other than the test SAP should be shutdown or should not receive any traffic.
- The configured CIR/PIR rate is rounded off to the nearest available hardware rates. User is provided with an option to select the adaptation rule to use (similar to support available for QoS policies).
- 7210 SAS supports all port speeds (that is, up to 1G rate). User needs to configure the appropriate loopback port to achieve a desired rate. For example, user must dedicate the resources of a 1G port, if intended to test rates to go up to 1G.
- ITU-T Y.1564 recommends to provide an option to configure the CIR step-size and the step-duration for the service configuration tests. This is not supported directly in 7210 SAS. It can be achieved by SAM or a third-party NMS system or an application with configuration of the desired rate and duration to correspond to the CIR step-size and step duration and repeating the test a second time, with a different value of the rate (that is, CIR step size) and duration (that is, step duration) and so on.
- Testhead waits for about 5 seconds at the end of the configured test duration before collecting statistics. This allows for all in-flight packets to be received by the node and accounted for in the test measurements. User cannot start another test during this period.
- When using testhead to test bandwidth available between SAPs configured in a VPLS service, operators must ensure that no other SAPs in the VPLS service are exchanging any traffic, particularly BUM traffic and unicast traffic destined to either the local test SAP or

the remote SAP. BUM traffic eats into the network resources which is also used by testhead traffic.

- It is possible that test packets (both data and/or marker packets) remain in the loop created for testing when the tests are killed. This is highly probably when using QoS policies with very less shaper rates resulting in high latency for packets flowing through the network loop. User must remove the loop at both ends once the test is complete or when the test is stopped and wait for a suitable time before starting the next test for the same service, to ensure that packets drain out of the network for that service. If this is not done, then the subsequent tests might process and account these stale packets, resulting in incorrect results. Software cannot detect stale packets in the loop as it does not associate or check each and every packet with a test session
- Traffic received from the remote node and looped back into the test port (where the test SAP is configured) on the local end (that is, the end where the testhead tool is invoked) is dropped by hardware after processing (and is not sent back to the remote end). The SAP ingress QoS policies and SAP ingress filter policies must match the packet header fields specified by the user in the testhead profile, except that the source/destination MAC addresses are swapped.
- Latency is not be computed if marker packets are not received by the local node where the test is generated and printed as 0 (zero), in such cases. If jitter = 0 and latency > 0, it means that jitter calculated is less than the precision used for measurement. There is also a small chance that jitter was not actually calculated, that is, only one value of latency has been computed. This typically indicates a network issue, rather than a testhead issue.
- When the throughput is not met, FLR cannot be calculated. If the measured throughput is approximately +/-10% of the user configured rate, FLR value is displayed; else software prints “Not Applicable”. The percentage of variance of measured bandwidth depends on the packet size in use and the configured rate.
- User must not use the CLI command to clear statistics of the test SAP port, testhead loopback port and MAC swap loopback port when the testhead tool is running. The port statistics are used by the tool to determine the Tx/Rx frame count.
- Testhead tool generates traffic at a rate slightly above the CIR. The additional bandwidth is attributable to the marker packets used for latency measurements. This is not expected to affect the latency measurement or the test results in a significant way.
- If the operational throughput is 1kbps and it is achieved in the test loop, the throughput computed could still be printed as 0 if it is < 1Kbps (0.99 kbps, for example). Under such cases, if FLR is PASS, the tool indicates that the throughput has been achieved.
- The testhead tool displays a failure result if the received count of frames is less than the injected count of frames, even though the FLR might be displayed as 0. This happens due to truncation of FLR results to 6 decimal places and can happen when the loss is very less.
- As the rate approaches 1Gbps or the maximum bandwidth achievable in the loop, user needs to account for the marker packet rate and the meter behavior while configuring the CIR rate. In other words, if the user wants to test 1Gbps for 512 bytes frame size, then they will need to configure about 962396Kbps, instead of 962406Kbps, the maximum rate

that can be achieved for this frame-size. In general, they would need to configure about 98%-99% (based on packet size) of the maximum possible rate to account for marker packets when they need to test at rates which are closer to bandwidth available in the network. The reason for this is that at the maximum rate, injection of marker packets by CPU will result in drops of either the injected data traffic or the marker packets themselves, as the net rate exceeds the capacity. These drops cause the testhead to always report a failure, unless the rate is marginally reduced.

- Testhead works with L2 rate, that is, the rate after subtracting the L1 overhead. The L1 overhead is due to IFG and Preamble added to every Ethernet frame and is typically about 20 bytes (IFG = 12 bytes and Preamble = 8 bytes). Depending on the frame size configured by the user, testhead tool computes the L2 rate and does not allow the user to configure a value greater than it. For 512 bytes Ethernet frame, L2 rate is 962406Kbps and L1 rate is 1Gbps.
- It is not expected that the operator will use the testhead tool to measure the throughput or other performance parameters of the network during the course of network event. The network events could be affecting the other SAP/SDP-Binding/PW configured in the service. Examples are transition of a SAP due to G8032 ring failure, transition of active/standby SDP-Binding/PW due to link or node failures.
- The 2-way delay (also known as “latency”) values measured by Testhead tool is more accurate than obtained using OAM tools, as the timestamps are generated in hardware.
- 7210 SAS does not support color-aware metering on access SAP ingress, therefore, any color-aware packets generated by the testhead is ignored on access SAP ingress. 7210 SAS service access port, access-uplink port, or network port can mark the packets appropriately on egress to allow the subsequent nodes in the network to differentiate the in-profile and out-of-profile packets and provide them with appropriate QoS treatment. 7210 SAS access-uplink ingress and network port ingress is capable of providing appropriate QoS treatment to in-profile and out-of-profile packets.
- The marker packets are sent over and above the configured CIR or PIR rate, the tool cannot determine the number of green packets injected and the number of yellow packets injected individually. Therefore, marker packets are not accounted in the injected or received green or in-profile and yellow or out-of-profile packet counts. They are only accounted for the Total Injected and the Total Received counts. So, the FLR metric accounts for marker packet loss (if any), while green or yellow FLR metric does not account for any marker packet loss.
- Marker packets are used to measure green or in-profile packets latency and jitter and the yellow or out-of-profile packets latency and jitter. These marker packets are identified as green or yellow based on the packet marking (Example: dot1p). The latency values can be different for green and yellow packets based on the treatment provided to the packets by the network QoS configuration.

- The following table provides details of SAP encapsulation that are supported for Testhead

**Table 13: SAP Encapsulations supported for testhead**

<b>Epipe service configured with svc-sap-type</b>	<b>Test SAP Encapsulations</b>
null-star	Null, :* , 0.* , Q.*
Any	Null , :0 , :Q , :Q1.Q2
dot1q-preserve	:Q

- The following combination of 1G and 10G port can be used, as long as the rate validated is less than or equal to 1Gbps.
    - The test SAP is a 10G port, uplink is 1G port and other ports (that is, uplink, mac-swap and testhead) are 1G port.
    - The test SAP is a 10G port, uplink is a 10G port and other ports (that is, mac-swap and testhead) are 1G port.
    - The test SAP is a 1G port, uplink is a 10G port and other ports (that is, mac-swap and testhead) are 1G port.
-

## Configuring testhead tool parameters

The following example displays a port loopback mac-swap using the service and SAP:

```
configure> system> loopback-no-svc-port testhead <port-id>
*A:7210SAS>config>system# info
-----
.....
resource-profile
    ingress-internal-tcam
        qos-sap-ingress-resource 5
        exit
        acl-sap-ingress 5
        exit
    exit
    egress-internal-tcam
    exit
exit
loopback-no-svc-port mac-swap 1/1/8 testhead 1/1/11
.....
```

The following example displays a port loopback with mac-swap on the remote end:

```
*A:7210SAS# configure system loopback-no-svc-port mac-swap 1/1/8
*A:7210SAS# configure system
*A:7210SAS>config>system# info
-----
alarm-contact-input 1
    shutdown
exit
alarm-contact-input 2
    shutdown
exit
alarm-contact-input 3
    shutdown
exit
alarm-contact-input 4
    shutdown
exit
resource-profile
    ingress-internal-tcam
        qos-sap-ingress-resource 5
        exit
        acl-sap-ingress 5
        exit
    exit
    egress-internal-tcam
    exit
exit
loopback-no-svc-port mac-swap 1/1/8 testhead 1/1/11
.....
```

The following example displays a testhead profile:

```
*A:7210SAS# configure test-oam testhead-profile 1
*A:7210SAS>config>test-oam>testhd-prof# info
-----
description "Testhead_Profile_1"
  frame-size 512
  rate cir 100 adaptation-rule max pir 200
  dot1p in-profile 2 out-profile 4
  frame-payload 1 payload-type tcp-ipv4 create
    description "Frame_Payload_1"
    dscp "af11"
    dst-ip ipv4 2.2.2.2
    dst-mac 00:00:00:00:00:02
    src-mac 00:00:00:00:00:01
    dst-port 50
    src-port 40
    ip-proto 6
    ip-tos 8
    ip-ttl 64
    src-ip ipv4 1.1.1.1
  exit
acceptance-criteria 1 create
  jitter-rising-threshold 100
  jitter-rising-threshold-in 100
  jitter-rising-threshold-out 100
  latency-rising-threshold 100
  latency-rising-threshold-in 100
  latency-rising-threshold-out 100
  loss-rising-threshold 100
  loss-rising-threshold-in 100
  loss-rising-threshold-out 100
  cir-threshold 1000
  pir-threshold 2000
exit
-----
*A:7210SAS>config>test-oam>testhd-prof#
```

The following command is used to execute the testhead profile:

```
*A:7210SAS# oam testhead testhead-profile 1 frame-payload 1 sap 1/1/2 test-me owner ownerme
color-aware enable
```

# Diagnostics Command Reference

- [OAM Commands on page 161](#)
- [SAA Commands on page 170](#)

---

## OAM Commands

### Base Operational Commands

#### GLOBAL

- **ping** *[ip-address | dns-name]* [**rapid** | **detail**] [**ttl** *time-to-live*] [**tos** *type-of-service*] [**size** *bytes*] [**pattern** *pattern*] [**source** *ip-address | dns-name*] [**interval** *seconds*] [{**next-hop** *ip-address*} | {**interface** *interface-name*} | **bypass-routing**] [**count** *requests*] [**do-not-fragment**] [**router** *router-instance*] **service-name** *service-name*] [**timeout** *timeout*] [**fc** *fc-name*]
  - **traceroute** *[ip-address | dns-name]* [**ttl** *ttl*] [**wait** *milli-seconds*] [**no-dns**][**source** *ip-address*] [**tos** *type-of-service*] [**router** [*router-instance* / **service-name** *service-name*]]
  - **oam**
    - **dns** **target-addr** *dns-name* **name-server** *ip-address* [**source** *ip-address*] [**count** *send-count*] [**timeout** *timeout*] [**interval** *interval*] [**record-type** {*ipv4-a-record*|*ipv6-aaaa-record*}]
    - **saa** *test-name* [**owner** *test-owner*] {**start** | **stop**} [**no-accounting**]
- 

### LSP Diagnostics

#### GLOBAL

- **oam**
  - **lsp-ping** *lsp-name* [**path** *path-name*]
  - **lsp-ping** **prefix** *ip-prefix/mask* [**path-destination** *ip-address*] [**interface** *if-name* | **next-hop** *ip-address*]
  - **lsp-ping** **static** *lsp-name* [**assoc-channel** *ipv4|non-ip|none*] [**dest-global-id** *global-id* **dest-node-id** *node-id*] [**force**] [**path-type** *active* | *working* | *protect*]
  - **lsp-trace** *lsp-name* [**path** *path-name*]
  - **lsp-trace** **prefix** *ip-prefix/mask* [**path-destination** *ip-address*] [**interface** *if-name* | **next-hop** *ip-address*]
  - **lsp-trace** **static** *lsp-name* [**assoc-channel** *ipv4|non-ip|none*] [**path-type** *active* | *working* | *protect*]

### TWAMP

#### GLOBAL

- **configure**
  - **test-oam**
    - **twamp**
      - **server**
        - [**no**] **prefix** {*ip-prefix / mask*} [**create**]

- [no] **description** *description string*
- [no] **max-conn-prefix** *count*
- [no] **max-sess-prefix** *count*
- [no] **shutdown**
- [no] **inactivity-timeout** *seconds*
- [no] **max-conn-server** *count*
- [no] **max-sess-server** *count*
- [no] **shutdown**

## SDP Diagnostics

Note: SDP diagnostics commands are not applicable for 7210 SAS devices configured in Access uplink mode.

## GLOBAL

## — oam

- **sdp-mtu** *orig-sdp-id* **size-inc** *start-octets end-octets* [**step** *step-size*] [**timeout** *timeout*] [**interval** *interval*]
- **sdp-ping** *orig-sdp-id* [**resp-sdp** *resp-sdp-id*] [**fc** *fc-name*] [**timeout** *seconds*] [**interval** *seconds*] [**size** *octets*] [**count** *send-count*] [**interval** *<interval>*]

## Common Service Diagnostics

**Note:** Only DNS command is supported by 7210 SAS devices configured in access uplink mode.

## GLOBAL

## — oam

- **svc-ping** {*ip-addr*} **service** *service-id* [**local-sdp**] [**remote-sdp**]
- **dns target-addr** *dns-name* **name-server** *ip-address* [**source** *ip-address*] [**count** *send-count*] [**timeout** *timeout*] [**interval** *interval*]
- **vprn-ping** *service-id* **service** *svc-name* **source** *ip-address* **destination** *ip-address* [**fc** *fc-name*] [**size** *size*] [**ttl** *vc-label-ttl*] [**return-control**] [**interval** *interval*] [**count** *send-count*] [**timeout** *timeout*]
- **vprn-trace** *service-id* **source** *src-ip* **destination** *ip-address* [**fc** *fc-name*] [**size** *size*] [**min-ttl** *vc-label-ttl*] [**max-ttl** *vc-label-ttl*] [**return-control**] [**probe-count** *sendcount*] [**interval** *interval*] [**timeout** *timeout*]

## VLL Diagnostics

**Note:** VLL diagnostics commands are not applicable for 7210 SAS devices configured in access uplink mode.

## GLOBAL

## — oam

- **vccv-ping** *sdp-id:vc-id* [**src-ip-address** *ip-addr* **dst-ip-address** *ip-addr* **pw-id** *pw-id*] [**reply-mode** {*ip-routed* | *control-channel*}] [**fc** *fc-name*] [**size** *octets*] [**send-count** *send-count*] [**timeout** *timeout*] [**interval** *interval*] [**ttl** *vc-label-ttl*]
- **vccv-ping** *spoke-sdp* **spoke-sdp** *spoke-sdp-id* [**reply-mode** *ip-routed* | *control-channel*] [**src-ip-address** *ip-addr* **dst-ip-address** *ip-addr*]
- **vccv-ping** *static* **static** *sdp-id:vc-id* [**assoc-channel** *ipv4* | *non-ip*] [**dest-global-id** *global-id* **dest-node-id** *node-id*] [**src-ip-address** *ip-addr*]
- **vccv-ping** *saii-type2* **saii-type2** *global-id:prefix:ac-id* **taii-type2** *global-id:prefix:ac-id* [**reply-mode** *ip-routed* | *control-channel*] [**src-ip-address** *ip-addr* **dst-ip-address** *ip-addr*]
- **vccv-ping** *spoke-sdp-fec* **spoke-sdp-fec** *spoke-sdp-fec-id* [**reply-mode** *ip-routed* | *control-channel*] [**saii-type2** *global-id:prefix:ac-id* **taii-type2** *global-id:prefix:ac-id*] [**src-ip-address** *ip-addr* **dst-ip-address** *ip-addr*]
- **options common to all vccv-ping cases:** [**count** *send-count*] [**fc** *fc-name*] [**profile** *in/out*] [**interval** *interval*] [**size** *octets*] [**timeout** *timeout*] [**ttl** *vc-label-ttl*]
- **vccv-trace** *sdp-id:vc-id* [**fc** *fc-name*] [**profile** {*in* | *out*}] [**size** *octets*] [**reply-mode** *ip-routed* | *control-channel*] [**probe-count** *probes-count*] [**timeout** *timeout*] [**interval** *interval*] [**min-ttl** *min-vc-label-ttl*] [**max-ttl** *max-vc-label-ttl*] [**max-fail** *no-response-count*] [**detail**]
- **vccv-trace** *static* **static** *sdp-id:vc-id* [**assoc-channel** *ipv4* | *non-ip*] [**src-ip-address** *ipv4-address*]
- **vccv-trace** *saii-type2* **saii-type2** *global-id:prefix:ac-id* **taii-type2** *global-id:prefix:ac-id* [**reply-mode** *ip-routed* | *control-channel*]
- **vccv-trace** *spoke-sdp-fec* **spoke-sdp-fec** *spoke-sdp-fec-id* [**reply-mode** *ip-routed* | *control-channel*] [**saii-type2** *global-id:prefix:ac-id* **taii-type2** *global-id:prefix:ac-id*]
- **options common to all vccv-trace cases:** [**detail**] [**fc** *fc-name*] [**profile** *in/out*] [**interval** *interval-value*] [**max-fail** *no-response-count*] [**max-ttl** *max-vc-label-ttl*] [**min-ttl** *min-vc-label-ttl*] [**probe-count** *probe-count*] [**size** *octets*] [**timeout** *timeout-value*]

---

## VPLS MAC Diagnostics

**Note:** VPLS diagnostics commands are not applicable for 7210 SAS devices configured in Access uplink mode.

### GLOBAL

#### — oam

- **cpe-ping service** *service-id destination ip-address source ip-address* [**source-mac** *ieee-address*] [**fc** *fc-name*] [**ttl** *vc-label-ttl*] [**count** *send-count*] [**send-control**] [**return-control**] [**interval** *interval*]
  - **mac-ping service** *service-id destination dst-ieee-address* [**source** *src-ieee-address*] [**fc** *fc-name*] [**size** *octets*] [**fc** *fc-name*] [**ttl** *vc-label-ttl*] [**send-count** *send-count*] [**send-control**] [**return-control**] [**interval** *interval*] [**timeout** *timeout*]
  - **mac-populate** *service-id mac ieee-address* [**flood**] [**age** *seconds*] [**force**] [**target-sap** *sap-id*] [**send-control**]
  - **mac-purge** *service-id target ieee-address* [**flood**] [**send-control**] [**register**]
  - **mac-trace service** *service-id destination ieee-address* [**source** *ieee-address*] [**fc** *fc-name*] [**size** *octets*] [**min-ttl** *vc-label-ttl*] [**max-ttl** *vc-label-ttl*] [**probe-count** *send-count*] [**send-control**] [**return-control**] [**interval** *interval*] [**timeout** *timeout*]
- 

## Ethernet in the First Mile (EFM) Commands

### GLOBAL

#### — oam

- **efm** *port-id local-loopback* {start | stop}
  - **efm** *port-id remote-loopback* {start | stop}
- 

## ETH-CFM OAM Commands

### oam

- **eth-cfm eth-test** *mac-address mep mep-id domain md-index association ma-index* [**priority** *priority*] [**data-length** *data-length*]
  - **eth-cfm linktrace** *mac-address mep mep-id domain md-index association ma-index* [**ttl** *ttl-value*]
  - **eth-cfm loopback** *mac-address mep mep-id domain md-index association ma-index* [**send-count** *send-count*] [**size** *data-size*] [**priority** *priority*]
  - **eth-cfm one-way-delay-test** *mac-address mep mep-id domain md-index association ma-index* [**priority** *priority*]
  - **eth-cfm two-way-delay-test** *mac-address mep mep-id domain md-index association ma-index* [**priority** *priority*]
  - **eth-cfm two-way-slm-test** *mac-address mep mep-id domain md-index association ma-index* [**fc** {**fc-name**}] [**profile** {in|out}] [**count** *send-count*] [**size** *data-size*] [**timeout** *timeout*] [**interval** *interval*]
-

## Y.1564 Testhead OAM commands

```

config
  — test-oam
    — testhead-profile profile-id create
      — [no] acceptance-criteria acceptance-criteria-id create
        — [no] cir-threshold threshold
        — [no] jitter-rising-threshold threshold
        — [no] jitter-rising-threshold-in threshold
        — [no] jitter-rising-threshold-out threshold
        — [no] latency-rising-threshold threshold
        — [no] latency-rising-threshold-in threshold
        — [no] latency-rising-threshold-out threshold
        — [no] loss-rising-threshold threshold
        — [no] loss-rising-threshold-in threshold
        — [no] loss-rising-threshold-out threshold
        — [no] pir-threshold threshold
      — [no] description description-string
      — dot1p in-profile dot1p-value out-profile dot1p-value
      — no dot1p
      — no frame-payload payload-id [payload-type [L2|tcp-ipv4|udp-ipv4|ipv4] create
      — no frame-payload payload
        — [no] data-pattern data-pattern
        — [no] description description-string
        — [no] dscp dscp-name
        — [no] dst-ip ipv4 ipv4-address
        — [no] dst-mac ieee-address [ieee-address-mask]
        — [no] dst-port dst-port-number
        — [no] ethertype 0x0600..0xffff
        — [no] ip-proto ip-protocol-number
        — [no] ip-tos type-of-service
        — [no] ip-ttl tll-value
        — [no] src-ip ipv4 ipv4-address
        — [no] src-mac ieee-address [ieee-address-mask]
        — [no] src-port src-port-number
        — [no] vlan-tag-1 vlan-id vlan-id [tpid tpid] [dot1p dot1p-value]
        — [no] vlan-tag-2 vlan-id vlan-id [tpid tpid] [dot1p dot1p-value]
      — [no] frame-size frame-size
      — [no] rate cir cir-rate-in-kbps [cir-adaptation-rule adaptation-rule] [pir cir-rate-i
        n-kbp]
      — [no] test-completion-trap-enable
      — [no] test-duration [hours hours] minutes minutes seconds seconds]
      — [no] test-duration

```

---

## Y.1564 Testhead OAM Commands

**oam**

- **testhead** *test-name* **owner** *owner-name* **testhead-profile** *profile-id* [**frame-payload** *frame-payload-id*]  
**sap** *sap-id* [**fc** *fc-name*] [**acceptance-criteria** *acceptance-criteria-id*] [**color-aware** **enable**|**disable**]
- **testhead** *test-name* **owner** *owner-name* **stop**

## Show commands

- show**
  - **test-oam**
  - **testhead-profile** *profile-id*
- show**
  - **testhead** [*test-name* **owner** *test-owner*] [**detail**]

## Clear commands

**clear**

- **test-oam**
  - **twamp server**
- **testhead result** [*test-name*] **owner** [*test-owner*]
- **testhead testhead-profile** *profile-id*

---

## SAA Commands

Note: The following commands are not supported by 7210 SAS devices configured in Access uplink mode:

- cpe-ping
- lsp-ping
- lsp-trace
- mac-ping
- mac-trace
- sdp-ping
- vccv-ping
- vccv-trace
- vprn-ping
- vprn-trace

---

### config

- **saa**
  - **[no] test** *test-name* [**owner** *test-owner*]
    - **accounting-policy** *acct-policy-id*
    - **no accounting-policy**
    - **[no] continuous**
    - **description** *description-string*
    - **no description**
    - **[no] jitter-event** **rising-threshold** *threshold* [**falling-threshold** *threshold*] [*direction*]
    - **[no] latency-event** **rising-threshold** *threshold* [**falling-threshold** *threshold*] [*direction*]
    - **[no] loss-event** **rising-threshold** *threshold* [**falling-threshold** *threshold*] [*direction*]
    - **probe-history** {**keep**|**drop**|**auto**}
    - **[no] shutdown**
    - **trap-gen**
      - **[no] probe-fail-enable**
      - **[no] probe-fail-threshold** *0..15*
      - **[no] test-completion-enable**
      - **[no] test-fail-enable**
      - **[no] test-fail-threshold** *0..15*
  - **[no] type**
    - **cpe-ping** **service** *service-id* **destination** *ip-address* **source** *ip-address* [**source-mac** *ieee-address*] [**fc** *fc-name*] [**[ttl** *vc-label-ttl*] [**send-count** *send-count*] [**send-control**] [**return-control**] [**interval** *interval*]

- **dns target-addr** *dns-name name-server ip-address* [**source** *ip-address*] [**send-count** *send-count*] [**timeout** *timeout*] [**interval** *interval*]
- **eth-cfm-linktrace** *mac-address mep mep-id domain md-index association ma-index* [**ttl** *ttl-value*] [**fc** {*fc-name*}] [**count** *send-count*] [**timeout** *timeout*] [**interval** *interval*] [**record-type** {*ipv4-a-record|ipv6-aaaa-record*}]
- **eth-cfm-loopback** *mac-address mep mep-id domain md-index association ma-index* [**size** *data-size*] [**fc** {*fc-name*}] [**count** *send-count*] [**timeout** *timeout*] [**interval** *interval*]
- **eth-cfm-two-way-delay** *mac-address mep mep-id domain md-index association ma-index* [**fc** {*fc-name*}] [**count** *send-count*] [**timeout** *timeout*] [**interval** *interval*]
- **eth-cfm-two-way-slm** *mac-address mep mep-id domain md-index association ma-index* [**fc** {*fc-name*}] [**profile** {*in|out*}] [**count** *send-count*] [**size** *data-size*] [**timeout** *timeout*] [**interval** *interval*]
- **icmp-ping** [*ip-address | dns-name*] [**rapid** | **detail**] [**ttl** *time-to-live*] [**tos** *type-of-service*] [**size** *bytes*] [**pattern** *pattern*] [**source** *ip-address*] [**interval** *seconds*] [{**next-hop** *ip-address*}] [{**interface** *interface-name*}] [**bypass-routing**] [**count** *requests*] [**do-not-fragment**] [*router-instance / service-name service-name*] [**timeout** *timeout*] [**fc** {*fc-name*}]
- **icmp-trace** [*ip-address | dns-name*] [**ttl** *time-to-live*] [**wait** *milli-seconds*] [**source** *ip-address*] [**tos** *type-of-service*] [*router-instance / service-name service-name*]
- **lsp-ping** { [*lsp-name*] [**path** *path-name*]} [{**prefix** *ip-prefix/mask*}] [**src-ip-address** *ip-address*] [**size** *octets*] [**ttl** *label-ttl*] [**timeout** *timeout*] [**interval** *interval*] [**fc** *fc-name*] [**profile** {*in | out*}] [**send-count** *send-count*] {*lsp-name* [**path** *path-name*]} [**fc** *fc-name*] [**size** *octets*] [**ttl** *label-ttl*] [**send-count** *send-count*] [**timeout** *timeout*] [**interval** *interval*]
- **lsp-trace** {*lsp-name* [**path** *path-name*]} [**fc** *fc-name*] [**max-fail** *no-response-count*] [**probe-count** *probes-per-hop*] [**size** *octets*] [**min-ttl** *min-label-ttl*] [**max-ttl** *max-label-ttl*] [**src-ip-address** *ip-address*] [**timeout** *timeout*] [**interval** *interval*]
- **mac-ping** *service service-id destination dst ieee-address* [**source** *src-ieee-address*] [**fc** *fc-name*] [**size** *octets*] [**ttl** *vc-label-ttl*] [**send-count** *send-count*] [**send-control**] [**return-control**] [**interval** *interval*] [**timeout** *timeout*]
- **mac-trace** *service service-id destination ieee-address* [**source** *src-ieee-address*] [**fc** *fc-name*] [**size** *octets*] [**min-ttl** *min-label-ttl*] [**max-ttl** *max-label-ttl*] [**send-count** *send-count*] [**send-control**] [**return-control**] [**interval** *interval*] [**timeout** *timeout*]
- **sd-ping** *orig-sdp-id [resp-sdp resp-sdp-id]* [**fc** *fc-name*] [**size** *octets*] [**send-count** *send-count*] [**timeout** *seconds*] [**interval** *seconds*]
- **vccv-ping** *sdp-id:vc-id [src-ip-address ip-addr dst-ip-address ip-addr pw-id pw-id]* [**reply-mode** {*ip-routed | control-channel*}] [**fc** *fc-name*] [**size** *octets*] [**send-count** *send-count*] [**timeout** *timeout*] [**interval** *interval*] [**ttl** *vc-label-ttl*]
- **vccv-trace** *sdp-id:vc-id [size octets]* [**min-ttl** *vc-label-ttl*] [**max-ttl** *vc-label-ttl*] [**max-fail** *no-response-count*] [**probe-count** *probe-count*] [**reply-mode** *ip-routed|control-channel*] [**timeout** *timeout-value*] [**interval** *interval-value*] [**fc** *fc-name*] [**detail**]
- **vprn-ping** *service-id service svc-name [src-ip-address ip-addr dst-ip-address ip-addr]* [**fc** *fc-name*] [**profile** {*in | out*}] [**size** *size*] [**ttl** *vc-label-ttl*] [**count** *send-count*] [**return-control**] [**timeout** *timeout*] [**interval** *seconds*]

- **vpn-trace** *service-id* **source** *src-ip* **destination** *dst-ip* [**fc** *fc-name*] [**profile** *in* | *out*] [**size** *size*] [**min-ttl** *vc-label-ttl*] [**max-ttl** *vc-label-ttl*] [**count** *send-count*] [**return-control**] [**timeout** *timeout*] [**interval** *interval*]

## Show Commands

### show

- **eth-cfm**
  - **association** [*ma-index*] [**detail**]
  - **cfm-stack-table** [**port** [*port-id* [**vlan** *qtag* [*.qtag*]]] | **sdp** *sdp-id*[:*vc-id*]] [**level** 0..7] [**direction** *up* / *down*]
  - **domain** [*md-index*] [**association** *ma-index* | **all-associations**] [**detail**]
  - **mep** *mep-id* **domain** *md-index* **association** *ma-index* [**loopback**] [**linktrace**]
  - **mep** *mep-id* **domain** *md-index* **association** *ma-index* [**remote-mepid** *mep-id* | **all-remote-mepids**]
  - **mep** *mep-id* **domain** *md-index* **association** *ma-index* **eth-test-results** [**remote-peer** *mac-address*]
  - **mep** *mep-id* **domain** *md-index* **association** *ma-index* **one-way-delay-test** [**remote-peer** *mac-address*]
  - **mep** *mep-id* **domain** *md-index* **association** *ma-index* **two-way-delay-test** [**remote-peer** *mac-address*]
  - **mep** *mep-id* **domain** *md-index* **association** *ma-index* **two-way-slm-test** [**remote-peer** *mac-address*]
  - **mip**
  - **system-config**
- **saa** [*test-name*] [**owner** *test-owner*]
- **test-oam**
  - **twamp server**
    - **server all**
    - **server prefix** *ip-prefix/mask*
    - **server**

## Clear Commands

### clear

- **saa** [*test-name*] [**owner** *test-owner*]
- **test-oam**
  - **twamp server**
    - **server**

---

## OAM and SAA Command Hierarchies

---

### Operational Commands

#### shutdown

**Syntax** [no] shutdown

**Context** config>saa>test

**Description** In order to modify an existing test it must first be shut down. When a test is created it will be in shutdown mode until a **no shutdown** command is executed.

A **shutdown** can only be performed if a test is not executing at the time the command is entered.

Use the **no** form of the command to set the state of the test to operational.

#### shutdown

**Syntax** [no] shutdown

**Context** config>test-oam>ldp-treetrace  
config>test-oam>twamp>server  
config>test-oam>twamp>server>prefix

**Description** This command suspends the background process running the LDP ECMP OAM tree discovery and path probing features. The configuration is not deleted.

Use the **no** form of the command to enable the background process.

#### dns

**Syntax** dns target-addr dns-name name-server ip-address [source ip-address] [count send-count] [timeout timeout] [interval interval] [record-type {ipv4-a-record|ipv6-aaaa-record}]

**Context** oam

**Description** This command performs DNS name resolution. If ipv4-a-record is specified, dns-names are queried for A-records only.

**Parameters** **send-count** *send-count* — The number of messages to send, expressed as a decimal integer. The **send-count** parameter is used to override the default number of message requests sent. Each message request must either timeout or receive a reply before the next message request is sent. The message **interval** value must be expired before the next message request is sent.

## Operational Commands

**Default** 1

**Values** 1 — 100

*ip-address* — The IP or IPv6 address of the primary DNS server.

**Values**

- ipv4-address - a.b.c.d
- ipv6-address - x:x:x:x:x:x:x (eight 16-bit pieces)  
x:x:x:x:x:d.d.d.d
- x - [0..FFFF]H
- d - [0..255]D

**timeout** *timeout* — The **timeout** parameter in seconds, expressed as a decimal integer. This value is used to override the default **timeout** value and is the amount of time that the router will wait for a message reply after sending the message request. Upon the expiration of message timeout, the requesting router assumes that the message response will not be received. Any response received after the request times out will be silently discarded.

**Default** 5

**Values** 1 — 120

**interval** *interval* — The **interval** parameter in seconds, expressed as a decimal integer. This parameter is used to override the default request message send interval and defines the minimum amount of time that must expire before the next message request is sent.

If the **interval** is set to 1 second, and the **timeout** value is set to 10 seconds, then the maximum time between message requests is 10 seconds and the minimum is 1 second. This depends upon the receipt of a message reply corresponding to the outstanding message request.

**Default** 1

**Values** 1 — 10

**record-type** — Specifies a record type.

**Values**

- ipv4-a-record — A record specific mapping a host name to an IPv4 address.
- ipv6-aaaa-record — A record specific to the Internet class that stores a single IPv6 address.

## ping

**Syntax** **ping** [*ip-address* | *dns-name*] [**rapid** | **detail**] [**ttl** *time-to-live*] [**tos** *type-of-service*] [**size** *bytes*] [**pattern** *pattern*] [**source** *ip-address* | *dns-name*] [**interval** *seconds*] [{**next-hop** *ip-address*} | {**interface** *interface-name*} | **bypass-routing**] [**count** *requests*] [**do-not-fragment**] [**router** *router-instance* | **service-name** *service-name*] [**timeout** *timeout*]

**Context** <GLOBAL>

**Description** This command verifies the reachability of a remote host.

**Parameters** *ip-address* — The far-end IP address to which to send the **sve-ping** request message in dotted decimal notation.

**Note:** IPv6 is supported only for "Management" instance of the router.

**Values**

ipv4-address:	a.b.c.d
ipv6-address:	x:x:x:x:x:x:x (eight 16-bit pieces)
	x:x:x:x:x:d.d.d.d
x:	[0 .. FFFF]H
d:	[0 .. 255]D

**dns-name** — The DNS name of the far-end device to which to send the **sve-ping** request message, expressed as a character string.

**rapid** — Packets will be generated as fast as possible instead of the default 1 per second.

**detail** — Displays detailed information.

**ttl time-to-live** — The TTL value for the MPLS label, expressed as a decimal integer.

**Values** 1 — 128

**tos type-of-service** — Specifies the service type.

**Values** 0 — 255

**size bytes** — The request packet size in bytes, expressed as a decimal integer.

**Values** 0 — 16384

**pattern pattern** — The data portion in a ping packet will be filled with the pattern value specified. If not specified, position info will be filled instead.

**Values** 0 — 65535

**source ip-address** — Specifies the IP address to be used.

**Note:** IPv6 is supported only for "Management" instance of the router.

**Values**

ipv4-address:	a.b.c.d
ipv6-address:	x:x:x:x:x:x:x (eight 16-bit pieces)
	x:x:x:x:x:d.d.d.d
x:	[0 .. FFFF]H
d:	[0 .. 255]D

**router router-instance** — Specifies the router name or service ID.

**Values** *router-name:* Base , management

**Default** Base

**service-name service-name** - Specifies the service name as an integer or string.

**bypass-routing** — Specifies whether to send the ping request to a host on a directly attached network bypassing the routing table.

**interface interface-name** — Specifies the name of an IP interface. The name must already exist in the **config>router>interface** context.

**next-hop ip-address** — Only displays static routes with the specified next hop IP address.

## Operational Commands

**Note:** IPv6 is supported only for "Management" instance of the router.

**Values**

ipv4-address:	a.b.c.d (host bits must be 0)
ipv6-address:	x:x:x:x:x:x:x (eight 16-bit pieces)
	x:x:x:x:x:d.d.d.d
x:	[0 — FFFF]H
d:	[0 — 255]

**interval seconds** — The interval parameter in seconds, expressed as a decimal integer. This parameter is used to override the default request message send interval and defines the minimum amount of time that must expire before the next message request is sent.

If the interval is set to 1 second, and the timeout value is set to 10 seconds, then the maximum time between message requests is 10 seconds and the minimum is 1 second. This depends upon the receipt of a message reply corresponding to the outstanding message request.

**Values** 1 — 10000

**count requests** — Specifies the number of times to perform an OAM ping probe operation. Each OAM echo message request must either timeout or receive a reply before the next message request is sent.

**Values** 1 — 100000

**Default** 5

**do-not-fragment** — Sets the DF (Do Not Fragment) bit in the ICMP ping packet.

**fc-name** — The forwarding class of the MPLS echo request encapsulation.

**Values** be|l2|af|l1|h2|ef|h1|nc

**Default** nc

**timeout seconds** — Overrides the default **timeout** value and is the amount of time that the router will wait for a message reply after sending the message request. Upon the expiration of message timeout, the requesting router assumes that the message response will not be received. A 'request timeout' message is displayed by the CLI for each message request sent that expires. Any response received after the request times out will be silently discarded.

**Default** 5

**Values** 1 — 10

## traceroute

**Syntax** **traceroute** [*ip-address* | *dns-name*] [**t***tl* *ttl*] [**w***ait* *milli-seconds*] [**n***o-dns*] [**s***ource* *ip-address*] [**t***os* *type-of-service*] [**r***outer* *router-instance* | **s***ervice-* *name* *service-name*]

**Context** Global

**Description** The TCP/IP traceroute utility determines the route to a destination address. DNS lookups of the responding hosts is enabled by default.

```
*A:ALA-1# traceroute 192.168.xx.xx4
traceroute to 192.168.xx.xx4, 30 hops max, 40 byte packets
 1 192.168.xx.xx4 0.000 ms 0.000 ms 0.000 ms
```

\*A:ALA-1#

**Parameters**

*ip-address* — The far-end IP address to which to send the traceroute request message in dotted decimal notation.

**Note:** IPv6 is supported only for "Management" instance of the router.

**Values**

ipv4-address:	a.b.c.d
ipv6-address:	x:x:x:x:x:x:x (eight 16-bit pieces)
	x:x:x:x:x:d.d.d.d
x:	[0 .. FFFF]H
d:	[0 .. 255]D

*dns-name* — The DNS name of the far-end device to which to send the traceroute request message, expressed as a character string.

**ttl** *ttl* — The maximum Time-To-Live (TTL) value to include in the traceroute request, expressed as a decimal integer.

**Values** 1 — 255

**wait** *milliseconds* — The time in milliseconds to wait for a response to a probe, expressed as a decimal integer.

**Default** 5000

**Values** 10 — 60000

**no-dns** — When the **no-dns** keyword is specified, DNS lookups of the responding hosts will not be performed, only the IP addresses will be printed.

**Default** DNS lookups are performed

**source** *ip-address* — The source IP address to use as the source of the probe packets in dotted decimal notation. If the IP address is not one of the device's interfaces, an error is returned.

**tos** *type-of-service* — The type-of-service (TOS) bits in the IP header of the probe packets, expressed as a decimal integer.

**Values** 0 — 255

**router** *router-name* — Specify the alphanumeric character string up to 32 characters.

**Values** Base, Management

**service-name** *service-name* - Specifies the service name as an integer or string.

## lsp-ping

**Syntax** **lsp-ping** *lsp-name* [**path** *path-name*]

**Context** **lsp-ping prefix** *ip-prefix/mask* [**path-destination** *ip-address* [**interface** *if-name* | **next-hop** *ip-address*]] [**src-ip-address** *ip-address*]

**lsp-ping** {{**lsp-name** [**path** *path-name*]} }{{**prefix** *ip-prefix/mask*}} [**src-ip-address** *ip-address*] [**size**

## Operational Commands

octets] [ttl label-ttl] [timeout timeout] [interval interval] [fc fc-name [profile {in | out}]] [send-count send-count] {lsp-name [path path-name]} [fc fc-name] [size octets][ttl label-ttl] [send-count send-count] [timeout timeout] [interval interval]

**lsp-ping static** *lsp-name* [assoc-channel ipv4|none|non-ip] [force] [dest-global-id *global-id* dest-node-id *node-id*] [path-type active | working | protect]

**NOTE:** Options common to all **lsp-ping** cases: [detail] [fc *fc-name* [profile in|out]] [interval *interval*] [send-count *send-count*] [size *octets*] [src-ip-address *ip-address*] [timeout *timeout*] [ttl *label-ttl*]

**Context** oam  
config>saa>test>type

**Description** This command, when used with the **static** option, performs in-band on-demand LSP connectivity verification tests for static MPLS-TP LSPs. For other LSP types, the **static** option should be excluded and these are described elsewhere in this user guide.

The **lsp-ping static** command performs an LSP ping using the protocol and data structures defined in the RFC 4379, Detecting Multi-Protocol Label Switched (MPLS) Data Plane Failures, as extended by RFC 6426, MPLS On-Demand Connectivity Verification and Route Tracing.

In an LSP ping, the originating device creates an MPLS echo request packet for the LSP and path to be tested, containing a static LSP target FEC stack TLV for the LSP. The MPLS echo request packet is sent through the data plane, encapsulated in either the LSP label or the MPLS-TP G-ACh channel, and awaits an MPLS echo reply packet from the device terminating the LSP. The status of the LSP is displayed when the MPLS echo reply packet is received.

In MPLS-TP, the echo request and echo reply messages are always sent in-band over the LSP, either in a G-ACh channel or encapsulated as an IP packet below the LSP label.

**Parameters** *lsp-name* — Name that identifies an LSP to ping. The LSP name can be up to 32 characters long.

**dest-global-id** *global-id* — The MPLS-TP global ID for the far end node of the LSP under test. If this is not entered, then the dest-global-id is taken from the LSP context.

**dest-node-id** *node-id* — The MPLS-TP global ID for the far end node of the LSP under test. If this is not entered, then the dest-global-id is taken from the LSP context.

**control-channel** { **none** | **non-ip** } — The encapsulation format to use for the LSP Ping echo request and echo reply packet.

**Values** none — IP encapsulation in an MPLS labeled packet

**Values** non-ip — MPLS-TP encapsulation without UDP/IP headers, in an MPLS-TP G-ACh on the LSP using channel type 0x025.

**Default** non-ip

**force** — Allows LSP Ping to test a path that is operationally down, including cases where MPLS-TP BFD CC/V is enabled and has taken a path down. This parameter is only allowed in the OAM context; it is not allowed for a test configured as a part of an SAA.

**Default** disabled

**path-type** { **active** | **working** | **protect** } — The LSP path to test.

**Default** active

**Values** active — The currently active path. If MPLS-TP linear protection is configured on the LSP, then this is the path that is selected by by MPLS-TP PSC protocol for sending user plane traffic. If MPLS-TP linear protection is not configured, then this will be the wokring path.

**Values** working — The working path of the MPLS-TP LSP.

**Values** protect — The protect path of the MPLS-TP LSP.

**path** *path-name* — The LSP path name along which to send the LSP ping request.

**Values** Any path name associated with the LSP.

**Default** The active LSP path.

**src-ip-address** *ip-addr* — Specifies the source IP address. This option is used when an OAM packet must be generated from a different address than the node’s system interface address. An example is when the OAM packet is sent over an LDP LSP and the LDP LSR-ID of the corresponding LDP session to the next-hop is set to an address other than the system interface address.

**Values** ipv4-address: a.b.c.d

**fc** *fc-name* — The fc and profile parameters are used to indicate the forwarding class and profile of the MPLS echo request packet.

When an MPLS echo request packet is generated in CPM and is forwarded to the outgoing interface, the packet is queued in the egress network queue corresponding to the specified fc and profile parameter values. The marking of the packet’s EXP is dictated by the LSP-EXP mappings on the outgoing interface.

When the MPLS echo request packet is received on the responding node, The fc and profile parameter values are dictated by the LSP-EXP mappings of the incoming interface.

When an MPLS echo reply packet is generated in CPM and is forwarded to the outgoing interface, the packet is queued in the egress network queue corresponding to the fc and profile parameter values determined by the classification of the echo request packet, which is being replied to, at the incoming interface. The marking of the packet’s EXP is dictated by the LSP-EXP mappings on the outgoing interface. The TOS byte is not modified. The following table summarizes this behavior:

**Table 14: Request Packet and Behavior**

cpm (sender node)	echo request packet: <ul style="list-style-type: none"> <li>• packet{tos=1, fc1, profile1}</li> <li>• fc1 and profile1 are as entered by user in OAM command or default values</li> <li>• tos1 as per mapping of {fc1, profile1} to IP precedence in network egress QoS policy of outgoing interface</li> </ul>
-------------------	---

**Table 14: Request Packet and Behavior (Continued)**

outgoing interface (sender node)	echo request packet: <ul style="list-style-type: none"> <li>• pkt queued as {fc1, profile1}</li> <li>• ToS field=tos1 not remarked</li> <li>• EXP=exp1, as per mapping of {fc1, profile1} to EXP in network egress QoS policy of outgoing interface</li> </ul>
Incoming interface (responder node)	echo request packet: <ul style="list-style-type: none"> <li>• packet{tos1, exp1}</li> <li>• exp1 mapped to {fc2, profile2} as per classification in network QoS policy of incoming interface</li> </ul>
cpm (responder node)	echo reply packet: <ul style="list-style-type: none"> <li>• packet{tos=1, fc2, profile2}</li> </ul>
outgoing interface (responder node)	echo reply packet: <ul style="list-style-type: none"> <li>• pkt queued as {fc2, profile2}</li> <li>• ToS filed= tos1 not remarked (reply inband or out-of-band)</li> <li>• EXP=exp2, if reply is inband, remarked as per mapping of {fc2, profile2} to EXP in network egress QoS policy of outgoing interface</li> </ul>
Incoming interface (sender node)	echo reply packet: <ul style="list-style-type: none"> <li>• packet{tos1, exp2}</li> <li>• exp2 mapped to {fc1, profile1} as per classification in network QoS policy of incoming interface</li> </ul>

The LSP-EXP mappings on the receive network interface controls the mapping of the message reply back at the originating router.

**Values** be, l2, af, l1, h2, ef, h1, nc

**Default** be

**src-ip-address** *ip-addr* — This parameter specifies the source IP address. This parameter is used when an OAM packet must be generated from a different address than the node's system interface address. For example, when the OAM packet is sent over an LDP LSP and the LDP LSR-ID of the corresponding LDP session to the next-hop is set to an address other than the system interface address.

**Values** ipv4-address: a.b.c.d

**profile** {in | out} — The profile state of the MPLS echo request packet.

**Default** out

**size** *octets* — The MPLS echo request packet size in octets, expressed as a decimal integer. The request payload is padded with zeroes to the specified size.

**Values** 1 — 9198

**Default** 1

**ttl** *label-ttl* — The TTL value for the MPLS label, expressed as a decimal integer.

**Values** 1 — 255

**Default** 255

**send-count** *send-count* — The number of messages to send, expressed as a decimal integer. The **send-count** parameter is used to override the default number of message requests sent. Each message request must either timeout or receive a reply before the next message request is sent. The message **interval** value must be expired before the next message request is sent.

**Values** 1 — 100

**Default** 1

**time-out** *interval* — The time-out parameter in seconds, expressed as a decimal integer. This value is used to override the default timeout value and is the amount of time that the router will wait for a message reply after sending the last probe for a particular test. Upon the expiration of timeout the test will be marked complete and no more packets will be processed for any of those request probes.

**Values** 1 — 10

**Default** 5

**interval** *interval* — The interval parameter in seconds, expressed as a decimal integer. This parameter is used to override the default request message send interval and defines the minimum amount of time that must expire before the next message request is sent.

**path-destination** *ip-address* — Specifies the IP address of the path destination from the range 127/8.

**interface** *interface-name* — Specifies the name of an IP interface. The name must already exist in the **config>router>interface** context.

**next-hop** *ip-address* — Only displays static routes with the specified next hop IP address.

ipv4-address: a.b.c.d (host bits must be 0)

**prefix** *ip-prefix/mask* — Specifies the address prefix and subnet mask of the target BGP IPv4 label route.

**static** *lsp-name* — Specifies an LSP ping route using the RFC 6426, *MPLS On-Demand Connectivity Verification and Route Tracing*, Target FEC Stack code point Static LSP.

**assoc-channel** **ipv4none|non-ip** — Specifies the launched echo request's usage of the Associated Channel (ACH) mechanism, when testing an MPLS-TP LSP.

**Values** **ipv4** — Use the

**none** — Use the Associated Channel mechanism described in RFC 6426, Section 3.3.

**non-ip** — Do not use an Associated Channel, as described in RFC 6426, Section 3.1.

**dest-global-id** *global-id* — Indicates the source MPLS-TP global identifier of the replying node. The value is copied from the reply's RFC 6426 Source Identifier TLV.

**Values** 0 — 4294967295

**Default** 0

**dest-node-id** *node-id* — Specifies the target MPLS-TP Node Identifier.

**Values** a.b.c.d | 1 — 4294967295>

**Default** 0

**path-type active | working | protect** — Specifies the type of an MPLS TP path.

**Values**  
**active** - test the currently-active path of the MPLS-TP LSP  
**working** - test the primary path of the MPLS-TP LSP  
**protect** - test the secondary path of the MPLS-TP LSP

### Sample Output

```
A:DUTA# oam lsp-ping prefix 4.4.4/32 detail
LSP-PING 4.4.4/32: 80 bytes MPLS payload
Seq=1, send from intf dut1_to_dut3, reply from 4.4.4.4
      udp-data-len=32 ttl=255 rtt=5.23ms rc=3 (EgressRtr)

---- LSP 4.4.4/32 PING Statistics ----
1 packets sent, 1 packets received, 0.00% packet loss
round-trip min = 5.23ms, avg = 5.23ms, max = 5.23ms, stddev = 0.000ms

=====
LDP LSR ID: 1.1.1.1
=====
Legend: U - Label In Use, N - Label Not In Use, W - Label Withdrawn
      WP - Label Withdraw Pending, BU - Alternate For Fast Re-Route
=====
LDP Prefix Bindings
=====
Prefix          IngLbl      EgrLbl      EgrIntf/    EgrNextHop
Peer
-----
4.4.4.4/32      131069N     131067      1/1/1       1.3.1.2
 3.3.3.3
4.4.4.4/32      131069U     131064      --           --
 6.6.6.6
-----
No. of Prefix Bindings: 2
=====
A:DUTA#
```

## lsp-trace

**Syntax** **lsp-trace** *lsp-name* [**path** *path-name*]  
**lsp-trace prefix** *ip-prefix/mask* [**path-destination** *ip-address* [**interface** *if-name* | **next-hop** *ip-address*]]  
**lsp-trace static** *lsp-name* [**assoc-channel** *ipv4|none|non-ip*] [**path-type** *active | working | protect*]

**NOTE:** Options common to all **lsp-trace** cases: [**detail**] [**downstream-map-tlv** *downstream-map-tlv*] [**fc** *fc-name*] [**profile** *in|out*] [**interval** *interval*] [**max-fail** *no-response-count*] [**max-ttl** *max-label-ttl*] [**min-ttl** *min-label-ttl*] [**probe-count** *probes-per-hop*] [**size** *octets*] [**src-ip-address** *ip-address*] [**timeout** *timeout*]

**Context** oam  
config>saa>test>type

**Description** This command, when used with the **static** option, performs in-band on-demand LSP traceroute tests for static MPLS-TP LSPs. For other LSP types, the **static** option should be excluded and these are described elsewhere in this user guide.

The **lsp-trace static** command performs an LSP trace using the protocol and data structures defined in the RFC 4379, Detecting Multi-Protocol Label Switched (MPLS) Data Plane Failures, as extended by RFC 6426, MPLS On-Demand Connectivity Verification and Route Tracing.

The LSP trace operation is modeled after the IP traceroute utility which uses ICMP echo request and reply packets with increasing TTL values to determine the hop-by-hop route to a destination IP.

In an LSP trace, the originating device creates an MPLS echo request packet for the LSP to be tested with increasing values of the TTL in the outermost label. The MPLS echo request packet is sent through the data plane and awaits a TTL exceeded response or the MPLS echo reply packet from the device terminating the LSP. The devices that reply to the MPLS echo request packets with the TTL exceeded and the MPLS echo reply are displayed.

In MPLS-TP, the echo request and echo reply messages are always sent in-band over the LSP, either in a G-ACh channel or encapsulated as an IP packet below the LSP label.

**Parameters** *lsp-name* — Name that identifies an LSP to ping. The LSP name can be up to 32 characters long.

**path** *path-name* — The LSP path name along which to send the LSP trace request.

**Values** Any path name associated with the LSP.

**Default** The active LSP path.

**control-channel** { **none** | **non-ip** } — The encapsulation format to use for the MPLS echo request and echo reply packet.

**Values** none — IP encapsulation in an MPLS labeled packet

**Values** non-ip — MPLS-TP encapsulation without UDP/IP headers, in an MPLS-TP G-ACh on the LSP using channel type 0x025.

**Default** non-ip

**size** *octets* — The size in octets, expressed as a decimal integer, of the MPLS echo request packet, including the IP header but not the label stack. The request payload is padded with zeroes to the specified size. Note that an OAM command is not failed if the user entered a size lower than the minimum required to build the packet for the echo request message. The payload is automatically padded to meet the minimum size.

**Values** [104..9198]

**Default** 1

**src-ip-address** *ip-addr* — Specifies the source IP address. This option is used when an OAM packet must be generated from a different address than the node's system interface address. An example is when the OAM packet is sent over an LDP LSP and the LDP LSR-ID of the corresponding LDP session to the next-hop is set to an address other than the system interface address.

**Values** ipv4-address: a.b.c.d

**min-ttl** *min-label-ttl* — The minimum TTL value in the MPLS label for the LSP trace test, expressed as a

## Operational Commands

decimal integer.

**Default** 1

**Values** 1 — 255

**max-ttl** *max-label-ttl* — The maximum TTL value in the MPLS label for the LDP tree trace test, expressed as a decimal integer.

**Values** 1 — 255

**Default** 30

**max-fail** *no-response-count* — The maximum number of consecutive MPLS echo requests, expressed as a decimal integer that do not receive a reply before the trace operation fails for a given TTL.

**Values** 1 — 255

**Default** 5

**probes-per-hop** — The number of messages to send, expressed as a decimal integer. The **send-count** parameter is used to override the default number of message requests sent. Each message request must either timeout or receive a reply before the next message request is sent. The message **interval** value must be expired before the next message request is sent.

**Values** 1 — 10

**Default** 1

**timeout** *timeout* — The **timeout** parameter in seconds, expressed as a decimal integer. This value is used to override the default **timeout** value and is the amount of time that the router will wait for a message reply after sending the message request. Upon the expiration of message timeout, the requesting router assumes that the message response will not be received. A 'request timeout' message is displayed by the CLI for each message request sent that expires. Any response received after the request times out will be silently discarded.

**Values** 1 — 60

**Default** 3

**interval** *interval* — The **interval** parameter in seconds, expressed as a decimal integer. This parameter is used to override the default request message send interval and defines the minimum amount of time that must expire before the next message request is sent.

If the **interval** is set to 1 second, and the **timeout** value is set to 10 seconds, then the maximum time between message requests is 10 seconds and the minimum is 1 second. This depends upon the receipt of a message reply corresponding to the outstanding message request.

**Values** 1 — 10

**Default** 1

**downstream-map-tlv** { **ddmap** | **dsmmap** } — LSP Trace commands with this option can only be executed if the control-channel is set to none. The DSMAP/DDMAP TLV is only included in the echo request message if the egress interface is either a numbered IP interface, or an unnumbered IP interface. The TLV will not be included if the egress interface is of type unnumbered-mpls-tp.

**fc** *fc-name* — The **fc** and **profile** parameters are used to indicate the forwarding class and profile of the MPLS echo request packet.

When an MPLS echo request packet is generated in CPM and is forwarded to the outgoing interface, the packet is queued in the egress network queue corresponding to the specified fc and profile parameter values. The marking of the packet's EXP is dictated by the LSP-EXP mappings on the outgoing interface.

When the MPLS echo request packet is received on the responding node, The fc and profile parameter values are dictated by the LSP-EXP mappings of the incoming interface.

When an MPLS echo reply packet is generated in CPM and is forwarded to the outgoing interface, the packet is queued in the egress network queue corresponding to the fc and profile parameter values determined by the classification of the echo request packet, which is being replied to, at the incoming interface. The marking of the packet's EXP is dictated by the LSP-EXP mappings on the outgoing interface. The TOS byte is not modified. The following table summarizes this behavior:

**Table 15: Request Packet and Behavior**

cpm (sender node)	echo request packet: <ul style="list-style-type: none"> <li>• packet{tos=1, fc1, profile1}</li> <li>• fc1 and profile1 are as entered by user in OAM command or default values</li> <li>• tos1 as per mapping of {fc1, profile1} to IP precedence in network egress QoS policy of outgoing interface</li> </ul>
outgoing interface (sender node)	echo request packet: <ul style="list-style-type: none"> <li>• pkt queued as {fc1, profile1}</li> <li>• ToS field=tos1 not remarked</li> <li>• EXP=exp1, as per mapping of {fc1, profile1} to EXP in network egress QoS policy of outgoing interface</li> </ul>
Incoming interface (responder node)	echo request packet: <ul style="list-style-type: none"> <li>• packet{tos1, exp1}</li> <li>• exp1 mapped to {fc2, profile2} as per classification in network QoS policy of incoming interface</li> </ul>
cpm (responder node)	echo reply packet: <ul style="list-style-type: none"> <li>• packet{tos=1, fc2, profile2}</li> </ul>
outgoing interface (responder node)	echo reply packet: <ul style="list-style-type: none"> <li>• pkt queued as {fc2, profile2}</li> <li>• ToS field= tos1 not remarked (reply inband or out-of-band)</li> <li>• EXP=exp2, if reply is inband, remarked as per mapping of {fc2, profile2} to EXP in network egress QoS policy of outgoing interface</li> </ul>
Incoming interface (sender node)	echo reply packet: <ul style="list-style-type: none"> <li>• packet{tos1, exp2}</li> <li>• exp2 mapped to {fc1, profile1} as per classification in network QoS policy of incoming interface</li> </ul>

**Values** be, l2, af, l1, h2, ef, h1, nc

**Default** be

**profile** {in | out} — The profile state of the MPLS echo request packet.

**Default** out

**path-destination** *ip-address* — Specifies the IP address of the path destination from the range 127/8.

**interface** *interface-name* — Specifies the name of an IP interface. The name must already exist in the con-fig>router>interface context.

**downstream-map-tlv** {*dsmap|ddmap|none*} — Specifies which format of the downstream mapping TLV to use in the LSP trace packet. The DSMAP TLV is the original format in RFC 4379. The DDMAP is the new enhanced format specified in RFC 6424. The user can also choose not to include the downstream mapping TLV by entering the value none.

**Default** Inherited from global configuration of downstream mapping TLV in option **mpls-echo-request-downstream-map** {*dsmap | ddmap* }.

### Sample Output

```
*A:Dut-A# oam lsp-trace prefix 10.20.1.6/32 downstream-map-tlv ddmap path-destination
127.0.0.1 detail lsp-trace to 10.20.1.6/32: 0 hops min, 0 hops max, 152 byte packets
1 10.20.1.2 rtt=3.44ms rc=8(DSRtrMatchLabel) rsc=1
   DS 1: ipaddr=127.0.0.1 ifaddr=0 iftype=ipv4Unnumbered MRU=1500
       label[1]=131070 protocol=3(LDP)
2 10.20.1.4 rtt=4.65ms rc=8(DSRtrMatchLabel) rsc=1
   DS 1: ipaddr=127.0.0.1 ifaddr=0 iftype=ipv4Unnumbered MRU=1500
       label[1]=131071 protocol=3(LDP)
3 10.20.1.6 rtt=7.63ms rc=3(EgressRtr) rsc=1 *A:Dut-A#
```

```
*A:Dut-C# oam lsp-trace "p_1" detail
lsp-trace to p_1: 0 hops min, 0 hops max, 116 byte packets
1 10.20.1.2 rtt=3.46ms rc=8(DSRtrMatchLabel)
   DS 1: ipaddr 10.20.1.4 ifaddr 3 iftype 'ipv4Unnumbered' MRU=1500 label=131071
proto=4(RSVP-TE)
2 10.20.1.4 rtt=3.76ms rc=8(DSRtrMatchLabel)
   DS 1: ipaddr 10.20.1.6 ifaddr 3 iftype 'ipv4Unnumbered' MRU=1500 label=131071
proto=4(RSVP-TE)
3 10.20.1.6 rtt=5.68ms rc=3(EgressRtr)
*A:Dut-C#
```

### Lsp-trace over a numbered IP interface

```
A:DUTA#
A:DUTA# oam lsp-trace prefix 5.5.5.5/32 detail
lsp-trace to 5.5.5.5/32: 0 hops min, 0 hops max, 104 byte packets
1 6.6.6.6 rtt=2.45ms rc=8(DSRtrMatchLabel)
   DS 1: ipaddr=5.6.5.1 ifaddr=5.6.5.1 iftype=ipv4Numbered MRU=1564 label=131071
proto=3(LDP)
2 5.5.5.5 rtt=4.77ms rc=3(EgressRtr)
A:DUTA#
```

### Lsp-trace over an unnumbered IP interface

```
*A:Dut-A# oam lsp-trace prefix 10.20.1.6/32 downstream-map-tlv ddmap path-destination
127.0.0.1 detail lsp-trace to 10.20.1.6/32: 0 hops min, 0 hops max, 152 byte packets
1 10.20.1.2 rtt=3.44ms rc=8(DSRtrMatchLabel) rsc=1
   DS 1: ipaddr=127.0.0.1 ifaddr=0 iftype=ipv4Unnumbered MRU=1500
       label[1]=131070 protocol=3(LDP)
2 10.20.1.4 rtt=4.65ms rc=8(DSRtrMatchLabel) rsc=1
   DS 1: ipaddr=127.0.0.1 ifaddr=0 iftype=ipv4Unnumbered MRU=1500
       label[1]=131071 protocol=3(LDP)
3 10.20.1.6 rtt=7.63ms rc=3(EgressRtr) rsc=1 *A:Dut-A#
```

## Operational Commands

```
*A:Dut-A# oam ldp-treetrace prefix 10.20.1.6/32

ldp-treetrace for Prefix 10.20.1.6/32:

      127.0.0.1, ttl = 3 dst = 127.1.0.255 rc = EgressRtr status = Done
Hops:      127.0.0.1      127.0.0.1

      127.0.0.1, ttl = 3 dst = 127.2.0.255 rc = EgressRtr status = Done
Hops:      127.0.0.1      127.0.0.1

ldp-treetrace discovery state: Done
ldp-treetrace discovery status: ' OK '
Total number of discovered paths: 2
Total number of failed traces: 0
```

## Service Diagnostics

### sdp-mtu

Note: This command is not supported on 7210 SAS-M and 7210 SAS-T devices configured in Access uplink mode.

**Syntax** **sdp-mtu** *orig-sdp-id* **size-inc** *start-octets end-octets* [**step** *step-size*] [**timeout** *timeout*] [**interval** *interval*]

**Context** oam

**Description** Performs MTU Path tests on an SDP to determine the largest path-mtu supported on an SDP. The **size-inc** parameter can be used to easily determine the **path-mtu** of a given SDP-ID. The forwarding class is assumed to be Best-Effort Out-of-Profile. The message reply is returned with IP encapsulation from the far-end 7210 SAS M. OAM request messages sent within an IP SDP must have the 'DF' IP header bit set to 1 to prevent message fragmentation.

To terminate an **sdp-mtu** in progress, use the CLI break sequence <Ctrl-C>.

**Special Cases** **SDP Path MTU Tests** — SDP Path MTU tests can be performed using the **sdp-mtu size-inc** keyword to easily determine the **path-mtu** of a given SDP-ID. The forwarding class is assumed to be Best-Effort Out-of-Profile. The message reply is returned with IP encapsulation from the far-end 7210 SAS M.

With each OAM Echo Request sent using the **size-inc** parameter, a response line is displayed as message output. The path MTU test displays incrementing packet sizes, the number sent at each size until a reply is received and the response message.

As the request message is sent, its size value is displayed followed by a period for each request sent of that size. Up to three requests will be sent unless a valid response is received for one of the requests at that size. Once a response is received, the next size message is sent.

The response message indicates the result of the message request.

After the last reply has been received or response timeout, the maximum size message replied to indicates the largest size OAM Request message that received a valid reply.

**Parameters** *orig-sdp-id* — The *sdp-id* to be used by **sdp-ping**, expressed as a decimal integer. The far-end address of the specified *sdp-id* is the expected *responder-id* within each reply received. The specified *sdp-id* defines the encapsulation of the SDP tunnel encapsulation used to reach the far end. This can be IP MPLS. If *orig-sdp-id* is invalid or administratively down or unavailable for some reason, the SDP echo request message is not sent and an appropriate error message is displayed (once the **interval** timer expires, **sdp-ping** will attempt to send the next request if required).

**Values** 1 — 17407

**size-inc** *start-octets end-octets* — Indicates an incremental path MTU test will be performed with by sending a series of message requests with increasing MTU sizes. The *start-octets* and *end-octets* parameters are described below.

*start-octets* — The beginning size in octets of the first message sent for an incremental MTU test, expressed as a decimal integer.

**Values** 40 — 9198

## Operational Commands

*end-octets* — The ending size in octets of the last message sent for an incremental MTU test, expressed as a decimal integer. The specified value must be greater than *start-octets*.

**Values** 40 — 9198

**step** *step-size* — The number of octets to increment the message size request for each message sent for an incremental MTU test, expressed as a decimal integer. The next size message will not be sent until a reply is received or three messages have timed out at the current size.

If the incremented size exceeds the *end-octets* value, no more messages will be sent.

**Default** 32

**Values** 1 — 512

**timeout** *timeout* — The **timeout** parameter in seconds, expressed as a decimal integer. This value is used to override the default **timeout** value and is the amount of time that the router will wait for a message reply after sending the message request. Upon the expiration of message timeout, the requesting router assumes that the message response will not be received. A 'request timeout' message is displayed by the CLI for each message request sent that expires. Any response received after the request times out will be silently discarded.

**Default** 5

**Values** 1 — 10

**interval** *interval* — The **interval** parameter in seconds, expressed as a decimal integer. This parameter is used to override the default request message send interval and defines the minimum amount of time that must expire before the next message request is sent.

If the **interval** is set to 1 second, and the **timeout** value is set to 10 seconds, then the maximum time between message requests is 10 seconds and the minimum is 1 second. This depends upon the receipt of a message reply corresponding to the outstanding message request.

**Default** 1

**Values** 1 — 10

### Output Sample SDP MTU Path Test Sample Output

```
*A:Dut-A# oam sdp-mtu 1201 size-inc 512 3072 step 256
Size      Sent      Response
-----
512       .         Success
768       .         Success
1024      .         Success
1280      .         Success
1536      .         Success
1792      .         Success
2048      .         Success
2304      .         Success
2560      .         Success
2816      .         Success
3072      .         Success

Maximum Response Size: 3072
*A:Dut-A#
```

## svc-ping

Note: This command is not supported on 7210 SAS-M and 7210 SAS-T devices configured in Access uplink mode.

**Syntax** **svc-ping** *ip-address* [**service** *service-id*] [**local-sdp**] [**remote-sdp**]

**Context** <GLOBAL>

**Description** Tests a service ID for correct and consistent provisioning between two service end points.

The **svc-ping** command accepts a far-end IP address and a *service-id* for local and remote service testing. The following information can be determined from **svc-ping**:

1. Local and remote service existence
2. Local and remote service state
3. Local and remote service type correlation
4. Local and remote customer association
5. Local and remote service-to-SDP bindings and state
6. Local and remote ingress and egress service label association

Unlike **sdp-ping**, only a single message will be sent per command; no count nor interval parameter is supported and round trip time is not calculated. A timeout value of 10 seconds is used before failing the request. The forwarding class is assumed to be Best-Effort Out-of-Profile

If no request is sent or a reply is not received, all remote information will be shown as N/A.

To terminate a **svc-ping** in progress, use the CLI break sequence <Ctrl-C>.

Upon request timeout, message response, request termination, or request error the following local and remote information will be displayed. Local and remote information will be dependent upon service existence and reception of reply.

Field	Description	Values
Request Result	The result of the <b>svc-ping</b> request message.	Sent - Request Timeout Sent - Request Terminated Sent - Reply Received Not Sent - Non-Existent Service-ID Not Sent - Non-Existent SDP for Service Not Sent - SDP For Service Down Not Sent - Non-existent Service Egress Label
Service-ID	The ID of the service being tested.	<i>service-id</i>

## Operational Commands

Field	Description	Values (Continued)
Local Service Type	The type of service being tested. If <i>service-id</i> does not exist locally, N/A is displayed.	Epipes TLS IES Mirror-Dest N/A
Local Service Admin State	The local administrative state of <i>service-id</i> . If the service does not exist locally, the administrative state will be Non-Existent.	Admin-Up Admin-Down Non-Existent
Local Service Oper State	The local operational state of <i>service-id</i> . If the service does not exist locally, the state will be N/A.	Oper-Up Oper-Down N/A
Remote Service Type	The remote type of service being tested. If <i>service-id</i> does not exist remotely, N/A is displayed.	Epipes, Ipipes TLS IES Mirror-Dest N/A
Remote Service Admin State	The remote administrative state of <i>service-id</i> . If the service does not exist remotely, the administrative state is Non-Existent.	Up Down Non-Existent
Local Service MTU	The local <b>service-mtu</b> for <i>service-id</i> . If the service does not exist, N/A is displayed.	<i>service-mtu</i> N/A
Remote Service MTU	The remote <b>service-mtu</b> for <i>service-id</i> . If the service does not exist remotely, N/A is displayed.	<i>remote-service-mtu</i> N/A
Local Customer ID	The local <i>customer-id</i> associated with <i>service-id</i> . If the service does not exist locally, N/A is displayed.	<i>customer-id</i> N/A
Remote Customer ID	The remote <i>customer-id</i> associated with <i>service-id</i> . If the service does not exist remotely, N/A is displayed.	<i>customer-id</i> N/A
Local Service IP Address	The local system IP address used to terminate remotely configured SDP-ID (as the <b>far-end</b> address). If an IP interface has not been configured to be the system IP address, N/A is displayed.	<i>system-ip-address</i> N/A
Local Service IP Interface Name	The name of the local system IP interface. If the local system IP interface has not been created, N/A is displayed.	<i>system-interface-name</i> N/A

Field	Description	Values (Continued)
Local Service IP Interface State	The state of the local system IP interface. If the local system IP interface has not been created, Non-Existent is displayed.	Up Down Non-Existent
Expected Far-end Address	The expected IP address for the remote system IP interface. This must be the <b>far-end</b> address entered for the <b>svc-ping</b> command.	<i>orig-sdp-far-end-addr</i> <i>dest-ip-addr</i> N/A
Actual Far-end Address	The returned remote IP address. If a response is not received, the displayed value is N/A. If the far-end service IP interface is down or non-existent, a message reply is not expected. <b>sdp-ping</b> should also fail.	<i>resp-ip-addr</i> N/A
Responders Expected Far-end Address	The expected source of the originator's <i>sdp-id</i> from the perspective of the remote router terminating the <i>sdp-id</i> . If the far-end cannot detect the expected source of the ingress <i>sdp-id</i> or the request is transmitted outside the <i>sdp-id</i> , N/A is displayed.	<i>resp-rec-tunnel-far-end-address</i> N/A
Originating SDP-ID	The <i>sdp-id</i> used to reach the <b>far-end</b> IP address if <b>sdp-path</b> is defined. The originating <i>sdp-id</i> must be bound to the <i>service-id</i> and terminate on the <b>far-end</b> IP address. If an appropriate originating <i>sdp-id</i> is not found, Non-Existent is displayed.	orig-sdp-id Non-Existent
Originating SDP-ID Path Used	Whether the Originating router used the originating <i>sdp-id</i> to send the <b>svc-ping</b> request. If a valid originating <i>sdp-id</i> is found, operational and has a valid egress service label, the originating router should use the <i>sdp-id</i> as the requesting path if <b>sdp-path</b> has been defined. If the originating router uses the originating <i>sdp-id</i> as the request path, Yes is displayed. If the originating router does not use the originating <i>sdp-id</i> as the request path, No is displayed. If the originating <i>sdp-id</i> is non-existent, N/A is displayed.	Yes No N/A
Originating SDP-ID Administrative State	The local administrative state of the originating <i>sdp-id</i> . If the <i>sdp-id</i> has been shutdown, Admin-Down is displayed. If the originating <i>sdp-id</i> is in the no shutdown state, Admin-Up is displayed. If an originating <i>sdp-id</i> is not found, N/A is displayed.	Admin-Up Admin-Up N/A
Originating SDP-ID Operating State	The local operational state of the originating <i>sdp-id</i> . If an originating <i>sdp-id</i> is not found, N/A is displayed.	Oper-Up Oper-Down N/A
Originating SDP-ID Binding Admin State	The local administrative state of the originating <i>sdp-ids</i> binding to <i>service-id</i> . If an <i>sdp-id</i> is not bound to the service, N/A is displayed.	Admin-Up Admin-Up N/A

## Operational Commands

Field	Description	Values (Continued)
Originating SDP-ID Binding Oper State	The local operational state of the originating <i>sdp-ids</i> binding to <i>service-id</i> . If an <i>sdp-id</i> is not bound to the service, N/A is displayed.	Oper-Up Oper-Down N/A
Responding SDP-ID	The <i>sdp-id</i> used by the far end to respond to the <b>svc-ping</b> request. If the request was received without the <b>sdp-path</b> parameter, the responding router will not use an <i>sdp-id</i> as the return path, but the appropriate responding <i>sdp-id</i> will be displayed. If a valid <i>sdp-id</i> return path is not found to the originating router that is bound to the <i>service-id</i> , Non-Existent is displayed.	<i>resp-sdp-id</i> Non-Existent
Responding SDP-ID Path Used	Whether the responding router used the responding <i>sdp-id</i> to respond to the <b>svc-ping</b> request. If the request was received via the originating <i>sdp-id</i> and a valid return <i>sdp-id</i> is found, operational and has a valid egress service label, the far-end router should use the <i>sdp-id</i> as the return <i>sdp-id</i> . If the far end uses the responding <i>sdp-id</i> as the return path, Yes is displayed. If the far end does not use the responding <i>sdp-id</i> as the return path, No is displayed. If the responding <i>sdp-id</i> is non-existent, N/A is displayed.	Yes No N/A
Responding SDP-ID Administrative State	The administrative state of the far-end <i>sdp-id</i> associated with the return path for <i>service-id</i> . When a return path is administratively down, Admin-Down is displayed. If the return <i>sdp-id</i> is administratively up, Admin-Up is displayed. If the responding <i>sdp-id</i> is non-existent, N/A is displayed.	Admin-Up Admin-Up N/A
Responding SDP-ID Operational State	The operational state of the far-end <i>sdp-id</i> associated with the return path for <i>service-id</i> . When a return path is operationally down, Oper-Down is displayed. If the return <i>sdp-id</i> is operationally up, Oper-Up is displayed. If the responding <i>sdp-id</i> is non-existent, N/A is displayed.	Oper-Up Oper-Down N/A
Responding SDP-ID Binding Admin State	The local administrative state of the responder's <i>sdp-id</i> binding to <i>service-id</i> . If an <i>sdp-id</i> is not bound to the service, N/A is displayed.	Admin-Up Admin-Down N/A
Responding SDP-ID Binding Oper State	The local operational state of the responder's <i>sdp-id</i> binding to <i>service-id</i> . If an <i>sdp-id</i> is not bound to the service, N/A is displayed.	Oper-Up Oper-Down N/A
Originating VC-ID	The originator's VC-ID associated with the <i>sdp-id</i> to the far-end address that is bound to <i>service-id</i> . If the <i>sdp-id</i> signaling is off, <i>originator-vc-id</i> is 0. If the <i>originator-vc-id</i> does not exist, N/A is displayed.	<i>originator-vc-id</i> N/A

Field	Description	Values (Continued)
Responding VC-ID	The responder's VC-ID associated with the <i>sdp-id</i> to <i>originator-id</i> that is bound to <i>service-id</i> . If the <i>sdp-id</i> signaling is off or the service binding to <i>sdp-id</i> does not exist, <i>responder-vc-id</i> is 0. If a response is not received, N/A is displayed.	<i>responder-vc-id</i> N/A
Originating Egress Service Label	The originating service label (VC-Label) associated with the <i>service-id</i> for the originating <i>sdp-id</i> . If <i>service-id</i> does not exist locally, N/A is displayed. If <i>service-id</i> exists, but the egress service label has not been assigned, Non-Existent is displayed.	<i>egress-vc-label</i> N/A Non-Existent
Originating Egress Service Label Source	The originating egress service label source. If the displayed egress service label is manually defined, Manual is displayed. If the egress service label is dynamically signaled, Signaled is displayed. If the <i>service-id</i> does not exist or the egress service label is non-existent, N/A is displayed.	Manual Signaled N/A
Originating Egress Service Label State	The originating egress service label state. If the originating router considers the displayed egress service label operational, Up is displayed. If the originating router considers the egress service label inoperative, Down is displayed. If the <i>service-id</i> does not exist or the egress service label is non-existent, N/A is displayed.	Up Down N/A
Responding Service Label	The actual responding service label in use by the far-end router for this <i>service-id</i> to the originating router. If <i>service-id</i> does not exist in the remote router, N/A is displayed. If <i>service-id</i> does exist remotely but the remote egress service label has not been assigned, Non-Existent is displayed.	<i>rec-vc-label</i> N/A Non-Existent
Responding Egress Service Label Source	The responder's egress service label source. If the responder's egress service label is manually defined, Manual is displayed. If the responder's egress service label is dynamically signaled, Signaled is displayed. If the <i>service-id</i> does not exist on the responder or the responder's egress service label is non-existent, N/A is displayed.	Manual Signaled N/A
Responding Service Label State	The responding egress service label state. If the responding router considers it is an egress service label operational, Up is displayed. If the responding router considers it is an egress service label inoperative, Down is displayed. If the <i>service-id</i> does not exist or the responder's egress service label is non-existent, N/A is displayed.	Up Down N/A
Expected Ingress Service Label	The locally assigned ingress service label. This is the service label that the far-end is expected to use for <i>service-id</i> when sending to the originating router. If <i>service-id</i> does not exist locally, N/A is displayed. If <i>service-id</i> exists but an ingress service label has not been assigned, Non-Existent is displayed.	<i>ingress-vc-label</i> N/A Non-Existent

## Operational Commands

Field	Description	Values (Continued)
Expected Ingress Label Source	The originator's ingress service label source. If the originator's ingress service label is manually defined, Manual is displayed. If the originator's ingress service label is dynamically signaled, Signaled is displayed. If the <i>service-id</i> does not exist on the originator or the originator's ingress service label has not been assigned, N/A is displayed.	Manual Signaled N/A
Expected Ingress Service Label State	The originator's ingress service label state. If the originating router considers it as an ingress service label operational, Up is displayed. If the originating router considers it as an ingress service label inoperative, Down is displayed. If the <i>service-id</i> does not exist locally, N/A is displayed.	Up Down N/A
Responders Ingress Service Label	The assigned ingress service label on the remote router. This is the service label that the far end is expecting to receive for <i>service-id</i> when sending to the originating router. If <i>service-id</i> does not exist in the remote router, N/A is displayed. If <i>service-id</i> exists, but an ingress service label has not been assigned in the remote router, Non-Existent is displayed.	<i>resp-ingress-vc-label</i> N/A Non-Existent
Responders Ingress Label Source	The assigned ingress service label source on the remote router. If the ingress service label is manually defined on the remote router, Manual is displayed. If the ingress service label is dynamically signaled on the remote router, Signaled is displayed. If the <i>service-id</i> does not exist on the remote router, N/A is displayed.	Manual Signaled N/A
Responders Ingress Service Label State	The assigned ingress service label state on the remote router. If the remote router considers it as an ingress service label operational, Up is displayed. If the remote router considers it as an ingress service label inoperative, Down is displayed. If the <i>service-id</i> does not exist on the remote router or the ingress service label has not been assigned on the remote router, N/A is displayed.	Up Down N/A
<b>Parameters</b>	<p><i>ip-address</i> — The far-end IP address to which to send the <b>svc-ping</b> request message in dotted decimal notation.</p> <p><b>service</b> <i>service-id</i> — The service ID of the service being tested must be indicated with this parameter. The service ID need not exist on the local to receive a reply message.</p> <p><b>Values</b>      1 — 2147483647</p> <p><b>local-sdp</b> — Specifies the <b>svc-ping</b> request message should be sent using the same service tunnel encapsulation labeling as service traffic. If <b>local-sdp</b> is specified, the command attempts to use an egress <i>sdp-id</i> bound to the service with the specified <b>far-end</b> IP address with the VC-Label for the service. The far-end address of the specified <i>sdp-id</i> is the expected <i>responder-id</i> within the reply received. The <i>sdp-id</i> defines the encapsulation of the SDP tunnel encapsulation used to reach the far end; this can be IP or MPLS. On originator egress, the service-ID must have an associated VC-Label to reach the far-end address of the <i>sdp-id</i> and the <i>sdp-id</i> must be operational for the message to be sent.</p>	

If **local-sdp** is not specified, the **svc-ping** request message is sent with encapsulation with the OAM label.

The following table indicates whether a message is sent and how the message is encapsulated based on the state of the service ID.

Local Service State	local-sdp Not Specified		local-sdp Specified	
	Message Sent	Message Encapsulation	Message Sent	Message Encapsulation
Invalid Local Service	Yes	Generic IP/OAM (PLP)	No	None
No Valid SDP-ID Bound	Yes	Generic IP/OAM (PLP)	No	None
SDP-ID Valid But Down	Yes	Generic IP/OAM (PLP)	No	None
SDP-ID Valid and Up, But No Service Label	Yes	Generic IP/OAM (PLP)	No	None
SDP-ID Valid, Up and Egress Service Label	Yes	Generic IP/OAM (PLP)	Yes	SDP Encapsulation with Egress Service Label (SLP)

**remote-sdp** — Specifies **svc-ping** reply message from the **far-end** should be sent using the same service tunnel encapsulation labeling as service traffic.

If **remote-sdp** is specified, the **far-end** responder attempts to use an egress *sdp-id* bound to the service with the message originator as the destination IP address with the VC-Label for the service. The *sdp-id* defines the encapsulation of the SDP tunnel encapsulation used to reply to the originator; this can be IP or MPLS. On responder egress, the service-ID must have an associated VC-Label to reach the originator address of the *sdp-id* and the *sdp-id* must be operational for the message to be sent.

The following table indicates how the message response is encapsulated based on the state of the remote service ID.

## Operational Commands

### Remote Service State

### Message Encapsulation

	remote-sdp Not Specified	remote-sdp Specified
Invalid Ingress Service Label	Generic IP/GRE OAM (PLP)	Generic IP/GRE OAM (PLP)
Invalid Service-ID	Generic IP/GRE OAM (PLP)	Generic IP/GRE OAM (PLP)
No Valid SDP-ID Bound on Service-ID	Generic IP/GRE OAM (PLP)	Generic IP/GRE OAM (PLP)
SDP-ID Valid But Down	Generic IP/GRE OAM (PLP)	Generic IP/GRE OAM (PLP)
SDP-ID Valid and Up, but No Service Label	Generic IP/GRE OAM (PLP)	Generic IP/GRE OAM (PLP)
SDP-ID Valid and Up, Egress Service Label, but VC-ID Mismatch	Generic IP/GRE OAM (PLP)	Generic IP/GRE OAM (PLP)
SDP-ID Valid and Up, Egress Service Label, but VC-ID Match	Generic IP/GRE OAM (PLP)	SDP Encapsulation with Egress Service Label (SLP)

### Sample Output

```
A:ALU_G7X1>config# oam svc-ping 10.20.1.3 service 1
Service-ID: 1
```

```
Err Info          Local          Remote
-----
Type:             EPIPE         EPIPE
Admin State:      Up            Up
==> Oper State:   Down          Down
Service-MTU:      1514         1514
Customer ID:      1            1

IP Interface State: Up
Actual IP Addr:   10.20.1.1    10.20.1.3
Expected Peer IP: 10.20.1.3    10.20.1.1

SDP Path Used:    No            No
SDP-ID:           1            2
Admin State:      Up            Up
Operative State: Up            Up
Binding Admin State: Up        Up
Binding Oper State: Up        Up
Binding VC ID:    10           10
Binding Type:     Spoke         Spoke
Binding Vc-type:  Ether         Ether
Binding Vlan-vc-tag: N/A       N/A

Egress Label:     131070       131068
Ingress Label:    131068       131070
Egress Label Type: Signaled    Signaled
Ingress Label Type: Signaled    Signaled
```

```
Request Result: Send - Reply Received: Responder Service ID Oper-Down
A:ALU_G7X1>config#
```

## vprn-ping

**Syntax** `vprn-ping service-id source ip-address destination ip-address [fc fc-name][size size] [ttl vc-label-ttl] [return-control] [interval interval] [send-count send-count] [timeout timeout]`

**Context** <GLOBAL>  
config>saa>test>type

**Description** This command performs a VPRN ping.

**Parameters** `service service-id` — The VPRN service ID to diagnose or manage.

**Values** `service-id:` 1 — 2147483647

`source ip-address` — The IP prefix for the source IP address in dotted decimal notation.

**Values** `ipv4-address:` 0.0.0.0 — 255.255.255.255

`destination ip-address` — The IP prefix for the destination IP address in dotted decimal notation.

**Values** 0.0.0.0 — 255.255.255.255

`size octets` — The OAM request packet size in octets, expressed as a decimal integer.

**Values** 1 — 9198

`ttl vc-label-ttl` — The TTL value in the VC label for the OAM request, expressed as a decimal integer.

**Default** 255

**Values** 1 — 255

`return-control` — Specifies the response to come on the control plane.

`interval interval` — The `interval` parameter in seconds, expressed as a decimal integer. This parameter is used to override the default request message send interval and defines the minimum amount of time that must expire before the next message request is sent.

If the `interval` is set to 1 second where the `timeout` value is set to 10 seconds, then the maximum time between message requests is 10 seconds and the minimum is 1 second. This depends upon the receipt of a message reply corresponding to the outstanding message request.

**Default** 1

**Values** 1 — 10 seconds

`send-count send-count` — The number of messages to send, expressed as a decimal integer. The `count` parameter is used to override the default number of message requests sent. Each message request must either timeout or receive a reply before the next message request is sent. The message `interval` value must be expired before the next message request is sent.

**Default** 1

**Values** 1 — 100

`timeout timeout` — The `timeout` parameter in seconds, expressed as a decimal integer. This value is used to override the default `timeout` value and is the amount of time that the router will wait for a message reply after sending the message request. Upon the expiration of message timeout, the requesting router assumes

## Operational Commands

that the message response will not be received. Any response received after the request times out will be silently discarded.

**Default** 5

**Values** 1 — 100

**fc-name** — The forwarding class of the MPLS echo request encapsulation.

**Default** be

**Values** be, l2, af, l1, h2, ef, h1, nc

### Sample Output

```
A:PE_1# oam vprn-ping 25 source 10.4.128.1 destination 10.16.128.0
Sequence Node-id                               Reply-Path Size      RTT
-----
[Send request Seq. 1.]
1          10.128.0.3:cpm                       In-Band   100      0ms
-----
...
A:PE_1#
-----
A:PE_1#
```

## vprn-trace

**Syntax** **vprn-trace** *service-id* **source** *src-ip* **destination** *ip-address* [**fc** *fc-name*] [**size** *size*] [**min-ttl** *vc-label-ttl*] [**max-ttl** *vc-label-ttl*] [**return-control**] [**send-count** *send-count*] [**interval** *seconds*] [**timeout** *timeout*]

**Context** <GLOBAL>  
config>saa>test>type

**Description** Performs VPRN trace.

**Parameters** **service** *service-id* — The VPRN service ID to diagnose or manage.

**Values** *service-id*: 1 — 2147483647

**source** *src-ip* — The IP prefix for the source IP address in dotted decimal notation.

**Values** *ipv4-address*: 0.0.0.0 — 255.255.255.255

**destination** *dst-ip* — The IP prefix for the destination IP address in dotted decimal notation.

**Values** 0.0.0.0 — 255.255.255.255

**size** *octets* — The OAM request packet size in octets, expressed as a decimal integer.

**Values** [1...9198]

**min-ttl** *vc-label-ttl* — The minimum TTL value in the VC label for the trace test, expressed as a decimal integer.

**Default** 1

**Values** 1 — 255

**max-ttl** *vc-label-ttl* — The maximum TTL value in the VC label for the trace test, expressed as a decimal integer.

**Default** 4

**Values** 1 — 255

**return-control** — Specifies the OAM reply to a data plane OAM request be sent using the control plane instead of the data plane.

**Default** OAM reply sent using the data plane.

**send-count** *sendcount* — The number of OAM requests sent for a particular TTL value, expressed as a decimal integer.

**Default** 1

**Values** 1 — 10

**interval** *seconds* — The **interval** parameter in seconds, expressed as a decimal integer. This parameter is used to override the default request message send interval and defines the minimum amount of time that must expire before the next message request is sent.

If the **interval** is set to 1 second where the **timeout** value is set to 10 seconds, then the maximum time between message requests is 10 seconds and the minimum is 1 second. This depends upon the receipt of a message reply corresponding to the outstanding message request.

**Default** 1

**Values** 1 — 10 seconds

**timeout** *timeout* — The **timeout** parameter in seconds, expressed as a decimal integer. This value is used to override the default **timeout** value and is the amount of time that the router will wait for a message reply after sending the message request. Upon the expiration of message timeout, the requesting router assumes that the message response will not be received. Any response received after the request times out will be silently discarded.

**Default** 3

**Values** 1 — 60

**fc-name** — The forwarding class of the MPLS echo request encapsulation.

**Default** be

**Values** be, l2, af, l1, h2, ef, h1, nc

### Sample Output

```
A:PE_1# oam vprn-trace 25 source 10.4.128.1 destination 10.16.128.0
TTL Seq Reply Node-id          Rcvd-on          Reply-Path RTT
-----
[Send request TTL: 1, Seq. 1.]
1  1  1  10.128.0.4          cpm              In-Band         0ms
  Requestor 10.128.0.1 Route: 0.0.0.0/0
```

## Operational Commands

```
Vpn Label: 131071 Metrics 0 Pref 170 Owner bgpVpn
Next Hops: [1] ldp tunnel
Route Targets: [1]: target:65100:1
Responder 10.128.0.4 Route: 10.16.128.0/24
Vpn Label: 131071 Metrics 0 Pref 170 Owner bgpVpn
Next Hops: [1] ldp tunnel
Route Targets: [1]: target:65001:100

[Send request TTL: 2, Seq. 1.]
2 1 1 10.128.0.3 cpm In-Band 0ms
Requestor 10.128.0.1 Route: 0.0.0.0/0
Vpn Label: 131071 Metrics 0 Pref 170 Owner bgpVpn
Next Hops: [1] ldp tunnel
Route Targets: [1]: target:65100:1
Responder 10.128.0.3 Route: 10.16.128.0/24
Vpn Label: 0 Metrics 0 Pref 0 Owner local
Next Hops: [1] ifIdx 2 nextHopIp 10.16.128.0

[Send request TTL: 3, Seq. 1.]
[Send request TTL: 4, Seq. 1.]
...
-----
A:PE_1#
```

## VPLS MAC Diagnostics

Note: VPLS MAC diagnostics commands are not supported on 7210 SAS-M and 7210 SAS-T devices configured in Access uplink mode.

### cpe-ping

**Syntax** **cpe-ping service** *service-id* **destination** *ip-address* **source** *ip-address* [**ttl** *vc-label-ttl*] [**return-control**] [**source-mac** *ieee-address*] [**fc** *fc-name*] [**interval** *interval*] [**count** *send-count*] [**send-control**]

**Context** oam  
config>saa>test>type

**Description** This ping utility determines the IP connectivity to a CPE within a specified VPLS service.

**Parameters** **service** *service-id* — The service ID of the service to diagnose or manage.

**Values** *service-id:* 1 — 2147483647

**destination** *ip-address* — Specifies the IP address to be used as the destination for performing an OAM ping operations.

**source** *ip-address* — Specify an unused IP address in the same network that is associated with the VPLS.

**ttl** *vc-label-ttl* — The TTL value in the VC label for the OAM MAC request, expressed as a decimal integer.

**Default** 255

**Values** 1 — 255

**return-control** — Specifies the MAC OAM reply to a data plane MAC OAM request be sent using the control plane instead of the data plane.

**Default** MAC OAM reply sent using the data plane.

**source-mac** *ieee-address* — Specify the source MAC address that will be sent to the CPE. If not specified or set to 0, the MAC address configured for the CPM is used.

**fc-name** — The forwarding class of the MPLS echo request encapsulation.

**Default** be

**Values** be, l2, af, l1, h2, ef, h1, nc

**interval** *interval* — The **interval** parameter in seconds, expressed as a decimal integer. This parameter is used to override the default request message send interval and defines the minimum amount of time that must expire before the next message request is sent.

If the **interval** is set to 1 second where the **timeout** value is set to 10 seconds, then the maximum time between message requests is 10 seconds and the minimum is 1 second. This depends upon the receipt of a message reply corresponding to the outstanding message request.

## Operational Commands

**Default** 1

**Values** 1 — 10

**count** *send-count* — The number of messages to send, expressed as a decimal integer. The **count** parameter is used to override the default number of message requests sent. Each message request must either time-out or receive a reply before the next message request is sent. The message **interval** value must be expired before the next message request is sent.

**Default** 1

**Values** 1 — 100

**send-control** — Specifies the MAC OAM request be sent using the control plane instead of the data plane.

**Default** MAC OAM request sent using the data plane.

## mac-populate

**Syntax** **mac-populate** *service-id mac ieee-address* [**flood**] [**age seconds**] [**force**] [*target-sap sap-id*] [*send-control*]

**Context** oam

**Description** This command populates the FIB with an OAM-type MAC entry indicating the node is the egress node for the MAC address and optionally floods the OAM MAC association throughout the service. The **mac-populate** command installs an OAM MAC into the service FIB indicating the device is the egress node for a particular MAC address. The MAC address can be bound to a particular SAP (the **target-sap**) or can be associated with the control plane in that any data destined to the MAC address is forwarded to the control plane (cpm). As a result, if the service on the node has neither a FIB nor an egress SAP, then it is not allowed to initiate a **mac-populate**.

The MAC address that is populated in the FIBs in the provider network is given a type OAM, so that it can be treated distinctly from regular dynamically learned or statically configured MACs. Note that OAM MAC addresses are operational MAC addresses and are not saved in the device configuration. An exec file can be used to define OAM MACs after system initialization.

The **force** option in **mac-populate** forces the MAC in the table to be type OAM in the case it already exists as a dynamic, static or an OAM induced learned MAC with some other type binding.

An OAM-type MAC cannot be overwritten by dynamic learning and allows customer packets with the MAC to either ingress or egress the network while still using the OAM MAC entry.

The **flood** option causes each upstream node to learn the MAC (that is, populate the local FIB with an OAM MAC entry) and to flood the request along the data plane using the flooding domain. The flooded **mac-populate** request can be sent via the data plane or the control plane. The **send-control** option specifies the request be sent using the control plane. If **send-control** is not specified, the request is sent using the data plane.

An **age** can be provided to age a particular OAM MAC using a specific interval. By default, OAM MAC addresses are not aged and can be removed with a **mac-purge** or with an FDB clear operation.

When split horizon group (SHG) is configured, the flooding domain depends on which SHG the packet originates from. The **target-sap** *sap-id* value dictates the originating SHG information.

- Parameters**
- service** *service-id* — The Service ID of the service to diagnose or manage.
    - Values** 1 — 2147483647
  - destination** *ieee-address* — The MAC address to be populated.
  - flood** — Sends the OAM MAC populate to all upstream nodes.
    - Default** MAC populate only the local FIB.
  - age** *seconds* — The age for the OAM MAC, expressed as a decimal integer.
    - Default** The OAM MAC does not age.
    - Values** 1 — 65535
  - force** — Converts the MAC to an OAM MAC even if it currently another type of MAC.
    - Default** Do not overwrite type.
  - target-sap** *sap-id* — The local target SAP bound to a service on which to associate the OAM MAC. By default, the OAM MAC is associated with the control plane, that is, it is associated with the CPU on the router.
    - When the **target-sap** *sap-id* value is not specified the MAC is bound to the CPM. The originating SHG is 0 (zero). When the **target-sap** *sap-id* value is specified, the originating SHG is the SHG of the target-sap.
    - Default** Associate OAM MAC with the control plane (CPU).
  - send-control** — Send the mac-purge request using the control plane.
    - Default** Request is sent using the data plane.

## mac-purge

**Syntax** **mac-purge** *service-id target ieee-address* [**flood**] [**send-control**] [**register**]

**Context** oam

**Description** This command removes an OAM-type MAC entry from the FIB and optionally floods the OAM MAC removal throughout the service. A **mac-purge** can be sent via the forwarding path or via the control plane. When sending the MAC purge using the data plane, the TTL in the VC label is set to 1. When sending the MAC purge using the control plane, the packet is sent directly to the system IP address of the next hop.

A MAC address is purged only if it is marked as OAM. A mac-purge request is an HVPLS OAM packet, with the following fields. The Reply Flags is set to 0 (since no reply is expected), the Reply Mode and Reserved fields are set to 0. The Ethernet header has source set to the (system) MAC address, the destination set to the broadcast MAC address. There is a VPN TLV in the FEC Stack TLV to identify the service domain.

If the register option is provided, the R bit in the Address Delete flags is turned on.

The **flood** option causes each upstream node to be sent the OAM MAC delete request and to flood the request along the data plane using the flooding domain. The flooded **mac-purge** request can be sent via the

## Operational Commands

data plane or the control plane. The **send-control** option specifies the request be sent using the control plane. If **send-control** is not specified, the request is sent using the data plane.

The **register** option reserves the MAC for OAM testing where it is no longer an active MAC in the FIB for forwarding, but it is retained in the FIB as a registered OAM MAC. Registering an OAM MAC prevents relearns for the MAC based on customer packets. Relearning a registered MAC can only be done through a **mac-populate** request. The originating SHG is always 0 (zero).

**Parameters** **service** *service-id* — The service ID of the service to diagnose or manage.

**Values** 1 — 2147483647

**target** *ieee-address* — The MAC address to be purged.

**flood** — Sends the OAM MAC purge to all upstream nodes.

**Default** MAC purge only the local FIB.

**send-control** — Send the mac-purge request using the control plane.

**Default** Request is sent using the data plane.

**register** — Reserve the MAC for OAM testing.

**Default** Do not register OAM MAC.

## mac-ping

**Syntax** **mac-ping service** *service-id destination dst-ieee-address* [**source** *src-ieee-address*] [**fc** *fc-name*] [**size** *octets*] [**tll** *vc-label-ttl*] [**count** *send-count*] [**send-control**] [**return-control**] [**interval** *interval*] [**timeout** *timeout*]

**Context** oam  
config>saa>test>type

**Description** The **mac-ping** utility is used to determine the existence of an egress SAP binding of a given MAC within a VPLS service.

A **mac-ping** packet can be sent through the control plane or the data plane. The **send-control** option specifies the request be sent using the control plane. If **send-control** is not specified, the request is sent using the data plane.

A **mac-ping** is forwarded along the flooding domain if no MAC address bindings exist. If MAC address bindings exist, then the packet is forwarded along those paths, provided they are active. A response is generated only when there is an egress SAP binding for that MAC address or if the MAC address is a “local” OAM MAC address associated with the device’s control plan.

A **mac-ping** reply can be sent using the data plane or the control plane. The **return-control** option specifies the reply be sent using the control plane. If **return-control** is not specified, the request is sent using the data plane.

A **mac-ping** with data plane reply can only be initiated on nodes that can have an egress MAC address binding. A node without a FIB and without any SAPs cannot have an egress MAC address binding, so it is not a node where replies in the data plane will be trapped and sent up to the control plane.

A control plane request is responded to through a control plane reply only.

By default, MAC OAM requests are sent with the system or chassis MAC address as the source MAC. The **source** option allows overriding of the default source MAC for the request with a specific MAC address.

When a **source** *ieee-address* value is specified and the source MAC address is locally registered within a split horizon group (SHG), then this SHG membership will be used as if the packet originated from this SHG. In all other cases, SHG 0 (zero) will be used. Note that if the **mac-trace** is originated from a non-zero SHG, such packets will not go out to the same SHG.

If EMG is enabled, mac-ping will return only the first SAP in each chain.

## Parameters

**service** *service-id* — The service ID of the service to diagnose or manage.

**Values** 1 — 2147483647

**destination** *ieee-address* — The destination MAC address for the OAM MAC request.

**size** *octets* — The MAC OAM request packet size in octets, expressed as a decimal integer. The request payload is padded to the specified size with a 6 byte PAD header and a byte payload of 0xAA as necessary. If the octet size specified is less than the minimum packet, the minimum sized packet necessary to send the request is used.

**Default** No OAM packet padding.

**Values** 1 — 9198

**ttl** *vc-label-ttl* — The TTL value in the VC label for the OAM MAC request, expressed as a decimal integer.

**Default** 255

**Values** 1 — 255

**send-control** — Specifies the MAC OAM request be sent using the control plane instead of the data plane.

**Default** MAC OAM request sent using the data plane.

**return-control** — Specifies the MAC OAM reply to a data plane MAC OAM request be sent using the control plane instead of the data plane.

**Default** MAC OAM reply sent using the data plane.

**source** *src-ieee-address* — The source MAC address from which the OAM MAC request originates. By default, the system MAC address for the chassis is used.

**Default** The system MAC address.

**Values** Any unicast MAC value.

**fc** *fc-name* — The **fc** parameter is used to test the forwarding class of the MPLS echo request packets. The actual forwarding class encoding is controlled by the network egress LSP-EXP mappings.

**Values** be, l2, af, l1, h2, ef, h1, nc

**interval** *interval* — The **interval** parameter in seconds, expressed as a decimal integer. This parameter is used to override the default request message send interval and defines the minimum amount of time that must expire before the next message request is sent.

If the **interval** is set to 1 second where the **timeout** value is set to 10 seconds, then the maximum time between message requests is 10 seconds and the minimum is 1 second. This depends upon the receipt of a message reply corresponding to the outstanding message request.

## Operational Commands

**Default** 1

**Values** 1 — 10

**count** *send-count* — The number of messages to send, expressed as a decimal integer. The **count** parameter is used to override the default number of message requests sent. Each message request must either time-out or receive a reply before the next message request is sent. The message **interval** value must be expired before the next message request is sent.

**Default** 1

**Values** 1 — 100

**timeout** *timeout* — The **timeout** parameter in seconds, expressed as a decimal integer. This value is used to override the default **timeout** value and is the amount of time that the router will wait for a message reply after sending the message request. Upon the expiration of message timeout, the requesting router assumes that the message response will not be received. Any response received after the request times out will be silently discarded.

**Default** 5

**Values** 1 — 10

## mac-trace

**Syntax** **mac-trace service** *service-id* **destination** *ieee-address* [**fc** *fc-name*] [**size** *octets*] [**min-ttl** *vc-label-ttl*] [**max-ttl** *vc-label-ttl*] [**send-control**] [**return-control**] [**source** *ieee-address*] [**send-count** *send-count*] [**interval** *interval*] [**timeout** *timeout*]

**Context** oam  
config>saa>test>type

**Description** This command displays the hop-by-hop path for a destination MAC address within a VPLS. The MAC traceroute operation is modeled after the IP traceroute utility which uses ICMP echo request and reply packets with increasing TTL values to determine the hop-by-hop route to a destination IP. The MAC traceroute command uses Alcatel-Lucent OAM packets with increasing TTL values to determine the hop-by-hop route to a destination MAC.

In a MAC traceroute, the originating device creates a MAC ping echo request packet for the MAC to be tested with increasing values of the TTL. The echo request packet is sent through the control plane or data plane and awaits a TTL exceeded response or the echo reply packet from the device with the destination MAC. The devices that reply to the echo request packets with the TTL exceeded and the echo reply are displayed.

When a **source** *ieee-address* value is specified and the source MAC address is locally registered within a split horizon group (SHG), then this SHG membership will be used as if the packet originated from this SHG. In all other cases, SHG 0 (zero) will be used. Note that if the **mac-ping** is originated from a non-zero SHG, such packets will not go out to the same SHG.

If EMG is enabled, mac-trace will return only the first SAP in each chain.

**Parameters** **service** *service-id* — The Service ID of the service to diagnose or manage.

**Values** 1 — 2147483647

**destination** *ieee-address* — The destination MAC address to be traced.

**size** *octets* — The MAC OAM request packet size in octets, expressed as a decimal integer. The request payload is padded to the specified size with a 6 byte PAD header and a byte payload of 0xAA as necessary. If the octet size specified is less than the minimum packet, the minimum sized packet necessary to send the request is used.

**Default** No OAM packet padding.

**Values** 1 — 9198

**fc** *fc-name* — The **fc** parameter is used to test the forwarding class of the MPLS echo request packets. The actual forwarding class encoding is controlled by the network egress LSP-EXP mappings.

**Values** be, l2, af, l1, h2, ef, h1, nc

**min-ttl** *vc-label-ttl* — The minimum TTL value in the VC label for the MAC trace test, expressed as a decimal integer.

**Default** 1

**Values** 1 — 255

**max-ttl** *vc-label-ttl* — The maximum TTL value in the VC label for the MAC trace test, expressed as a decimal integer.

**Default** 4

**Values** 1 — 255

**send-control** — Specifies the MAC OAM request be sent using the control plane instead of the data plane.

**Default** MAC OAM request sent using the data plane.

**return-control** — Specifies the MAC OAM reply to a data plane MAC OAM request be sent using the control plane instead of the data plane.

**Default** MAC OAM reply sent using the data plane.

**source** *ieee-address* — The source MAC address from which the OAM MAC request originates. By default, the system MAC address for the chassis is used.

**Default** The system MAC address.

**Values** Any unicast MAC value.

**send-count** *send-count* — The number of MAC OAM requests sent for a particular TTL value, expressed as a decimal integer.

**Default** 1

**Values** 1 — 10

**interval** *interval* — The **interval** parameter in seconds, expressed as a decimal integer. This parameter is used to override the default request message send interval and defines the minimum amount of time that must expire before the next message request is sent.

If the **interval** is set to 1 second, and the **timeout** value is set to 10 seconds, then the maximum time between message requests is 10 seconds and the minimum is 1 second. This depends upon the receipt of a message reply corresponding to the outstanding message request.

## Operational Commands

**Default** 1

**Values** 1 — 10

**timeout** *timeout* — The **timeout** parameter in seconds, expressed as a decimal integer. This value is used to override the default **timeout** value and is the amount of time that the router will wait for a message reply after sending the message request. Upon the expiration of message timeout, the requesting router assumes that the message response will not be received. Any response received after the request times out will be silently discarded.

**Default** 5

**Values** 1 — 60

---

## EFM Commands

### efm

**Syntax** *port-id*

**Context** oam>efm

**Description** This command enables Ethernet in the First Mile (EFM) OAM tests loopback tests on the specified port. The EFM OAM remote loopback OAMPDU will be sent to the peering device to trigger remote loopback.

**Parameters** *port-id* — Specify the port ID in the slot/mda/port format.

### local-loopback

**Syntax** **local-loopback** {start | stop}

**Context** oam>efm

**Description** This command enables local loopback tests on the specified port.

### remote-loopback

**Syntax** **remote-loopback** {start | stop}

**Context** oam>efm

**Description** This command enables remote Ethernet in the First Mile (EFM) OAM loopback tests on the specified port. The EFM OAM remote loopback OAMPDU will be sent to the peering device to trigger remote loopback.

---

## ETH-CFM OAM Commands

### linktrace

**Syntax** `linktrace mac-address mep mep-id domain md-index association ma-index [ttl ttl-value]`

**Context** `oam>eth-cfm`

**Default** The command specifies to initiate a linktrace test.

**Parameters** *mac-address* — Specifies a unicast destination MAC address.

**mep** *mep-id* — Specifies the target MAC address.

**Values** 1 — 8191

**domain** *md-index* — Specifies the MD index.

**Values** 1 — 4294967295

**association** *ma-index* — Specifies the MA index.

**Values** 1 — 4294967295

**ttl** *ttl-value* — Specifies the TTL for a returned linktrace.

**Values** 0 — 255

**Default** 64

### loopback

**Syntax** `loopback mac-address mep mep-id domain md-index association ma-index [send-count send-count] [size data-size] [priority priority]`

**Context** `oam>eth-cfm`

**Default** The command specifies to initiate a loopback test.

**Parameters** *mac-address* — Specifies a unicast MAC address.

**mep** *mep-id* — Specifies target MAC address.

**Values** 1 — 8191

**domain** *md-index* — Specifies the MD index.

**Values** 1 — 4294967295

**association** *ma-index* — Specifies the MA index.

**Values** 1 — 4294967295

**send-count** *send-count* — Specifies the number of messages to send, expressed as a decimal integer. Loopback messages are sent back to back, with no delay between the transmissions.

**Default** 1

**Values** 1 — 5

**size** *data-size* — This is the size of the data portion of the data TLV. If 0 is specified no data TLV is added to the packet.

**Values** 0 — 1500

**priority** *priority* — Specifies a 3-bit value to be used in the VLAN tag, if present, in the transmitted frame.

**Values** 0 — 7

## eth-test

**Syntax** *mac-address mep mep-id domain md-index association ma-index* [**priority** *priority*] [**data-length** *data-length*]

**Context** oam>eth-cfm

**Description** This command issues an ETH-CFM test.

**Parameters** *mac-address* — Specifies a unicast MAC address.

**mep** *mep-id* — Specifies target MAC address.

**Values** 1 — 8191

**domain** *md-index* — Specifies the MD index.

**Values** 1 — 4294967295

**association** *ma-index* — Specifies the MA index.

**Values** 1 — 4294967295

**data-length** *data-length* — Indicates the UDP data length of the echo reply, the length starting after the IP header of the echo reply.

**Values** 64 — 1500

**Default** 64

**priority** *priority* — Specifies the priority.

**Values** 0 — 7

**Default** The CCM and LTM priority of the MEP

## one-way-delay-test

<b>Syntax</b>	<b>one-way-delay-test</b> <i>mac-address</i> <b>mep</b> <i>mep-id</i> <b>domain</b> <i>md-index</i> <b>association</b> <i>ma-index</i> [ <b>priority</b> <i>priority</i> ]
<b>Context</b>	oam>eth-cfm
<b>Description</b>	This command issues an ETH-CFM one-way delay test.
<b>Parameters</b>	<i>mac-address</i> — Specifies a unicast MAC address. <b>mep</b> <i>mep-id</i> — Specifies target MAC address. <b>Values</b> 1 — 8191 <b>domain</b> <i>md-index</i> — Specifies the MD index. <b>Values</b> 1 — 4294967295 <b>association</b> <i>ma-index</i> — Specifies the MA index. <b>Values</b> 1 — 4294967295 <b>priority</b> <i>priority</i> — Specifies the priority. <b>Values</b> 0 — 7 <b>Default</b> The CCM and LTM priority of the MEP.

## two-way-delay-test

<b>Syntax</b>	<b>two-way-delay-test</b> <i>mac-address</i> <b>mep</b> <i>mep-id</i> <b>domain</b> <i>md-index</i> <b>association</b> <i>ma-index</i> [ <b>priority</b> <i>priority</i> ]
<b>Context</b>	oam>eth-cfm
<b>Description</b>	This command issues an ETH-CFM two-way delay test.
<b>Parameters</b>	<i>mac-address</i> — Specifies a unicast MAC address. <b>mep</b> <i>mep-id</i> — Specifies target MAC address. <b>Values</b> 1 — 8191 <b>domain</b> <i>md-index</i> — Specifies the MD index. <b>Values</b> 1 — 4294967295 <b>association</b> <i>ma-index</i> — Specifies the MA index. <b>Values</b> 1 — 4294967295 <b>priority</b> <i>priority</i> — Specifies the priority. <b>Values</b> 0 — 7 <b>Default</b> The CCM and LTM priority of the MEP.

## two-way-slm-test

**Syntax** **two-way-slm-test** *mac-address* **mep** *mep-id* **domain** *md-index* **association** *ma-index* [**priority** *priority*] [**send-count** *send-count*] [**size** *data-size*] [**timeout** *timeout*] [**interval** *interval*]

**Context** oam>eth-cfm

**Description** This command configures an Ethernet CFM two-way SLM test in SAA.

*mac-address* — Specifies a unicast destination MAC address.

**mep** *mep-id* — Specifies the target MAC address.

**Values** 1 — 8191

**domain** *md-index* — Specifies the MD index.

**Values** 1 — 4294967295

**association** *ma-index* — Specifies the MA index.

**Values** 1 — 4294967295

**priority** *priority* — Specifies a 3-bit value to be used in the VLAN tag, if present, in the transmitted frame.

**send-count** *send-count* — The number of messages to send, expressed as a decimal integer. The **count** parameter is used to override the default number of message requests sent. Each message request must either timeout or receive a reply before the next message request is sent. The message **interval** value must be expired before the next message request is sent.

**Default** 1

**Values** 1 — 1000

**size** *data-size* — This is the size of the data portion of the data TLV. If 0 is specified no data TLV is added to the packet.

**Default** 0

**Values** 0 — 1500

**timeout** *timeout* — The **timeout** parameter in seconds, expressed as a decimal integer. This value is used to override the default **timeout** value and is the amount of time that the router waits for a reply message after sending the message request. Upon the expiration of message timeout, the requesting router assumes that the message response is not received. Any response received after the request times out is silently discarded.

**Default** 5

**Values** 1 — 10

**interval** *interval* — The **interval** parameter in seconds, expressed as a decimal integer. This parameter is used to override the default request message send interval and defines the minimum amount of time that must expire before the next message request is sent.

If the **interval** is set to 1 second, and the **timeout** value is set to 10 seconds, then the maximum time

## Operational Commands

between message requests is 10 seconds and the minimum is 1 second. This depends upon the receipt of a message reply corresponding to the outstanding message request.

**Default** 5

**Values** [0.1, 0.2, .. 0.9] | [1, 2, .. 10]

---

## Testhead Commands

### test-oam

**Syntax** `test-oam`

**Context** `config`

**Description** This command enables the context to configure Operations, Administration, and Maintenance test parameters

### testhead-profile

**Syntax** `testhead-profile profile-id create`

**Context** `config> test-oam`

**Description** Provides the context to the create service testhead profiles which is used by the Y.1564/RFC 2544 testhead (also known as, traffic generator) OAM tool. A service testhead profile allows user to configure the parameters such as contents of the frame payload that is generated by traffic generator, the size of the frame, test duration, test acceptance criteria, and other criteria to be used by the testhead tool.

The profile is used the testhead OAM tool to generate the appropriate frame at the configured rate and measure the performance parameters (FD, FDV, and loss). At the end of the test run, the tool compares the measured values against the test acceptance criteria that is configured in the profile to determine if the service is within bounds of the acceptance criteria or not.

The no form the command removes user created profile from the system.

**Default** `none`

**Parameters** `profile-id` — Identifies the profile.

**Values** 1-10

### description

**Syntax** `description profile-description`

**Context** `config> test-oam>testhead-profile`

**Description** Allows user to associate a description with profile.  
The no form the command removes description.

**Default** `none`

## Operational Commands

**Parameters** *profile-description* — Provides a way to add a description to the profile based on its use or as per user choice.

**Values** ASCII string

### rate

**Syntax** **[no] rate cir-rate-in-kbps [cir-adaptation-rule adaptation-rule] [pir cir-rate-in-kbps]**

**Context** config> test-oam>testhead-profile

**Description** The testhead tool generates traffic up to the configured CIR rate, if the PIR rate is not specified. In other words, CIR rate specifies the bandwidth or throughput the user needs to validate. User can specify the optional PIR rate. If the PIR rate is specified, it needs to be greater than or equal to the CIR rate and the testhead generates traffic up to the configured PIR rate.

The *cir-adaptation-rule* parameter rule can be specified to let the system derive the operational hardware rate for both the CIR and PIR rate. This allows the software to find the best operational rate based on the user specified constraint and the hardware based rate steps supported on the platform. For more information about the hardware rate steps supported for meters on different platforms, see the “7210 SAS QoS User Guide”.

The no form of the command sets the CIR to default and PIR is not set. If the test is run after executing no rate command, the test generates traffic up to CIR rate. If PIR rate is specified, it must be greater than or equal to the CIR rate.

**Default** rate cir 1000kbps adaptation-rule closest

**Parameters** *cir-rate* — The cir parameter overrides the default administrative CIR to use. When the rate command has not been executed or the cir parameter is not explicitly specified, the default CIR is assumed. Fractional values are not allowed and must be given as a positive integer. The actual CIR rate is dependent on the meter’s adaptation-rule parameters and the hardware. It is specified in kilo-bits per second (kbps).

**Values** 0 — 10000000, max

*adaptation-rule* — Defines the constraints enforced when adapting the CIR and PIR rate defined with the rate command to the hardware rates supported by the platform. This parameter requires a qualifier that defines the constraint used when deriving the operational CIR and PIR value. If this parameter is not specified then the default adaptation-rule closest is applied.

**Values** [closest|max|min]

*max* - The max (maximum) option is mutually exclusive with the min and closest options. When max is defined, the operational CIR will be the next multiple of the hardware step-size that is equal to or lesser than the specified rate. The hardware step-size is determined by the configured administrative CIR and varies based on the platform.

*min* - The min (minimum) option is mutually exclusive with the max and closest options. When min is defined, the operational PIR will be the next multiple of the hardware step-size that is equal to or lesser than the specified rate. The hardware step-size is determined by the configured administrative CIR and varies based on the platform.

*closest* - The closest parameter is mutually exclusive with the min and max parameter.

When *closest* is defined, the operational CIR will be the next multiple of the hardware step-size that is equal to or lesser than the specified rate. The hardware step-size is determined by the configured administrative CIR and varies based on the platform.

*pir-rate* — The *pir* parameter overrides the default administrative PIR to use. When the *rate* command has not been executed or the PIR parameter is not explicitly specified, the default PIR is assumed. Fractional values are not allowed and must be given as a positive integer. The actual PIR rate is dependent on the meter's adaptation-rule parameters and the hardware. The value is specified in kilo-bits per second (kbps).

**Values** 0 — 10000000, max

## test-duration

**Syntax** `test-duration {[hours hours] [minutes minutes] [seconds seconds]}`

**Context** `config> test-oam>testhead-profile`

**Description** This command allows the user to specify the total test duration to be used for throughput measurement. The CLI parameters, *hours*, *minutes*, and *seconds*, allows the user to specify the number of hours, number of minutes and number of seconds to used for throughput measurement. User can specify all the parameters together. If all the parameters are specified together then the total test duration is set to the sum of the values specified for *hours*, *minutes* and *seconds*.

The no form of the command sets the value to the default value

**Default** no *test-duration* (sets the test duration for 3 minutes).

**Parameters** *hours* — The total number of hours to run the test. The total test duration is determined by the sum of the *hours*, *minutes* and *seconds* specified by the user.

**Values** 0 - 24

*minutes* — The total number of minutes to run the test. The total test duration is determined by the sum of the *hours*, *minutes* and *seconds* specified by the user.

**Values** 0 — 60

*seconds* — The total number of seconds to run the test. The total test duration is determined by the sum of the *hours*, *minutes* and *seconds* specified by the user.

**Values** 0 — 60

## frame-size

<b>Syntax</b>	<b>[no] frame-size [64..9212]</b>
<b>Context</b>	config> test-oam>testhead-profile
<b>Description</b>	This command allows the user to specify the frame size of the packets generated by the testhead tool. Any frame size in the given range can be specified.  The no form of the command sets the value to the default value
<b>Default</b>	no frame-size - set to a default value of 1514 bytes.
<b>Parameters</b>	<i>frame-size</i> — The size of the frame generated by the testhead tool. Choose from among the value allowed in the available range.  <b>Values</b> 64 ... 9212

## acceptance-criteria

<b>Syntax</b>	<b>[no] acceptance-criteria <i>acceptance-criteria-id</i> create</b>
<b>Context</b>	configure> test-oam> testhead-profile
<b>Description</b>	This command provides the context to specify the test acceptance criteria to be used by the testhead OAM tool to declare the PASS/FAIL result at the completion of the test.  User can create upto 4 different acceptance criteria per profile to measure different SLA needs. User has an option to specify only one of the acceptance criteria to be specified with the testhead OAM tool during the invocation of the test.  The no form of the command removes the test acceptance criteria.
<b>Default</b>	no defaults
<b>Parameters</b>	<i>acceptance-criteria-id</i> — A number to identify the test acceptance criteria. It is a decimal number used to identify the test acceptance criteria and to use when starting the throughput test.  <b>Values</b> 1- 4

## cir-threshold

<b>Syntax</b>	<b>[no] cir-threshold <i>cir-threshold</i></b>
<b>Context</b>	configure> test-oam> testhead-profile> acceptance-criteria
<b>Description</b>	The specified value for the CIR rate is compared with the measured CIR rate at the end of the test to declare the test result. If the measured value is greater than the specified value the test is declared as 'PASS', else it is considered to be 'FAIL'.

The no form of the command disables the comparison of the parameter with the measured value at the end of the test. Basically, the threshold value is ignored and not considered for declaring the test result.

**Default** no cir-threshold

**Parameters** *threshold* — Specifies the value for comparison with measured value

**Values** 0 – 1000000kbps

## pir-threshold

**Syntax** **[no]** **pir-threshold** *pir-threshold*

**Context** configure> test-oam> testhead-profile> acceptance-criteria

**Description** The specified value for the PIR rate is compared with the measured PIR rate at the end of the test to declare the test result. If the measured value is greater than the specified value the test is declared as 'PASS', else it is considered to be 'FAIL'.

The no form of the command disables the comparison of the parameter with the measured value at the end of the test. Basically, the threshold value is ignored and not considered for declaring the test result.

**Default** no pir-threshold

**Parameters** *threshold* — Specifies the value for comparison with measured value

**Values** 0 – 1000000kbps

## latency-rising-threshold

**Syntax** **[no]** **latency-rising-threshold** *threshold*

**Context** configure> test-oam> testhead-profile> acceptance-criteria

**Description** The specified value for the latency is compared with the measured latency at the end of the test to declare the test result. If the measured value is greater than the specified value the test is declared as 'FAIL', else it is considered to be 'PASS'.

The no form of the command disables the comparison of the parameter with the measured value at the end of the test. Basically, the threshold value is ignored and not considered for declaring the test result.

**Default** no latency-rising-threshold

**Parameters** *threshold* — Specifies the value for comparison with measured value.

**Values** [0..2147483000], Specified in microseconds.

## latency-rising-threshold-in

<b>Syntax</b>	<b>[no] latency-rising-threshold-in</b> <i>in-profile-threshold</i>
<b>Context</b>	configure> test-oam> testhead-profile> acceptance-criteria
<b>Description</b>	<p>The specified value for the latency is compared with the measured latency for green/in-profile packets at the end of the test to declare the test result. If the measured value is greater than the specified value the test is declared as 'FAIL', else it is considered to be 'PASS'.</p> <p>The no form of the command disables the comparison of the parameter with the measured value at the end of the test. Basically, the threshold value is ignored and not considered for declaring the test result.</p>
<b>Default</b>	no latency-rising-threshold-in
<b>Parameters</b>	<i>In-profile-threshold</i> — Specifies the value for comparison with measured value
<b>Values</b>	[0..2147483000], Specified in microseconds.

## latency-rising-threshold-out

<b>Syntax</b>	<b>[no] latency-rising-threshold out-profile-threshold</b>
<b>Context</b>	configure> test-oam> testhead-profile> acceptance-criteria
<b>Description</b>	<p>The specified value for the latency is compared with the measured latency of yellow or out-of-profile packets at the end of the test to declare the test result. If the measured value is greater than the specified value the test is declared as 'FAIL', else it is considered to be 'PASS'.</p> <p>The no form of the command disables the comparison of the parameter with the measured value at the end of the test. Basically, the threshold value is ignored and not considered for declaring the test result.</p>
<b>Default</b>	no latency-rising-threshold-out
<b>Parameters</b>	<i>out-profile-threshold</i> — Specifies the value for comparison with measured value
<b>Values</b>	[0..2147483000], Specified in microseconds.

## jitter-rising-threshold

<b>Syntax</b>	<b>[no] jitter-rising-threshold</b> <i>threshold</i>
<b>Context</b>	configure> test-oam> testhead-profile> acceptance-criteria
<b>Description</b>	<p>The specified value for the jitter is compared with the measured jitter at the end of the test to declare the test result. If the measured value is greater than the specified value the test is declared as 'FAIL', else it is considered to be 'PASS'.</p> <p>The no form of the command disables the comparison of the parameter with the measured value at the end of the test. Basically, the threshold value is ignored and not considered for declaring the test result.</p>

**Default** no jitter-rising-threshold

**Parameters** *threshold* — Specifies the value for comparison with measured value.

**Values** [0..2147483000], Specified in microseconds.

## jitter-rising-threshold-in

**Syntax** [**no**] jitter-rising-threshold-in *in-profile-threshold*

**Context** configure> test-oam> testhead-profile> acceptance-criteria

**Description** The specified value for the jitter is compared with the measured jitter for green/in-profile packets at the end of the test to declare the test result. If the measured value is greater than the specified value the test is declared as 'FAIL', else it is considered to be 'PASS'.

The no form of the command disables the comparison of the parameter with the measured value at the end of the test. Basically, the threshold value is ignored and not considered for declaring the test result.

**Default** no jitter-rising-threshold-in

**Parameters** *In-profile-threshold* — Specifies the value for comparison with measured value

**Values** [0..2147483000], Specified in microseconds.

## jitter-rising-threshold-out

**Syntax** [**no**] jitter-rising-threshold-out *out-profile-threshold*

**Context** configure> test-oam> testhead-profile> acceptance-criteria

**Description** The specified value for the jitter is compared with the measured jitter for yellow/out-of-profile packets at the end of the test to declare the test result. If the measured value is greater than the specified value the test is declared as 'FAIL', else it is considered to be 'PASS'.

The no form of the command disables the comparison of the parameter with the measured value at the end of the test. Basically, the threshold value is ignored and not considered for declaring the test result.

**Default** no jitter-rising-threshold-out

**Parameters** *out-profile-threshold* — Specifies the value for comparison with measured value

**Values** [0..2147483000], Specified in microseconds.

## loss-rising-threshold

<b>Syntax</b>	<b>[no] loss-rising-threshold</b> <i>threshold</i>
<b>Context</b>	configure> test-oam> testhead-profile> acceptance-criteria
<b>Description</b>	<p>The specified value for the Frame Loss Ratio (FLR) is compared with the measured FLR at the end of the test to declare the test result. If the measured value is greater than the specified value the test is declared as 'FAIL', else it is considered to be 'PASS'.</p> <p>Frame Loss Ratio is computed as a ratio of the difference of number of received frames to number of injected or sent frames divided by the number of sent frames.</p> <p>The no form of the command disables the comparison of the parameter with the measured value at the end of the test. Basically, the threshold value is ignored and not considered for declaring the test result.</p>
<b>Default</b>	no loss-rising-threshold
<b>Parameters</b>	<i>threshold</i> — Specifies the value for comparison with measured value.
<b>Values</b>	1 – 1000000, Loss-rising-threshold is specified as a number which denotes one ten-thousandth (1/10000) of a percent. For example, specifying a value of 1 is equivalent to 0.0001%, and specifying a value of 10000 is equivalent to 1%.

## loss-rising-threshold-in

<b>Syntax</b>	<b>[no] loss-rising-threshold-in</b> <i>in-profile-threshold</i>
<b>Context</b>	configure> test-oam> testhead-profile> acceptance-criteria
<b>Description</b>	<p>The specified value for the frame loss ratio (FLR) is compared with the measured FLR for green or in-profile packets at the end of the test to declare the test result. If the measured value is greater than the specified value the test is declared as 'FAIL', else it is considered to be 'PASS'.</p> <p>Frame Loss Ratio for green/in-profile packets is computed as a ratio of the difference of number of received green or in-profile frames to number of injected/sent green/in-profile frames divided by the number of sent green frames.</p> <p>The no form of the command disables the comparison of the parameter with the measured value at the end of the test. Basically, the threshold value is ignored and not considered for declaring the test result.</p>
<b>Default</b>	no loss-rising-threshold-in
<b>Parameters</b>	<i>in-profile-threshold</i> — Specifies the value for comparison with measured value
<b>Values</b>	1 – 1000000, Loss-rising-threshold is specified as a number which denotes one ten-thousandth (1/10000) of a percent. For example, specifying a value of 1 is equivalent to 0.0001%, and specifying a value of 10000 is equivalent to 1%.

## loss-rising-threshold-out

<b>Syntax</b>	<b>[no] loss-rising-threshold-out</b> <i>out-profile-threshold</i>
<b>Context</b>	configure> test-oam> testhead-profile> acceptance-criteria
<b>Description</b>	<p>The specified value for the frame loss ratio (FLR) is compared with the measured FLR for yellow/out-of-profile packets at the end of the test to declare the test result. If the measured value is greater than the specified value the test is declared as 'FAIL', else it is considered to be 'PASS'.</p> <p>Frame Loss ratio for yellow/out-of-profile packets is computed as a ratio of the difference of number of received yellow frames to number of injected/sent yellow frames divided by the number of sent yellow frames.</p> <p>The no form of the command disables the comparison of the parameter with the measured value at the end of the test. Basically, the threshold value is ignored and not considered for declaring the test result.</p>
<b>Default</b>	no loss-rising-threshold
<b>Parameters</b>	<i>out-profile-threshold</i> — Specifies the value for comparison with measured value
<b>Values</b>	1 – 1000000, Loss-rising-threshold is specified as a number which denotes one ten-thousandth (1/10000) of a percent. For example, specifying a value of 1 is equivalent to 0.0001%, and specifying a value of 10000 is equivalent to 1%.

## test-completion-trap-enable

<b>Syntax</b>	<b>[no] test-completion-trap-enable</b>
<b>Context</b>	configure> test-oam> testhead-profile
<b>Description</b>	<p>Executing this command allows the user to specify that the test completion trap needs to be generated after the completion of the test or if the test is stopped. The trap contains the details of test configuration, the measured values, test completion status and PASS/FAIL result.</p> <p>The no form of the command disables the generation of the event/log/trap after test completion.</p>
<b>Default</b>	no test-completion-trap-enable – that is, trap is not generated on completion of the test.

## dot1p

<b>Syntax</b>	<b>[no] dot1p in-profile</b> <i>dot1p-value</i> <b>out-of-profile</b> <i>dot1p-value</i>
<b>Context</b>	configure> test-oam> testhead-profile
<b>Description</b>	<p>This command allows the user to configure the Dot1p values to identify the in-profile or green packets and out-of-profile or yellow packets. The values configured using this command are used by the testhead tool on the local end (that is, the node on which the testhead tool is executed) to match the dot1p values received in the packet header and identify green and yellow packets and appropriately account the packets. These values are used only when the testhead tool is invoked with the parameter <i>color-aware</i> is set to 'enable'.</p>

## Operational Commands

The dot1p in-profile value (that is, packets with dot1p values in the L2 header equal to the dot1p-in-profile value configured is considered to be in-profile or green packet) is used to count the number of in-profile packets and measure the latency, jitter, and FLR for in-profile packets. Similarly, the dot1p out-profile is used to count the total out-of-profile or yellow packets and measure latency, jitter, and FLR for out-of-profile or yellow packets.

While the testhead tool is initiated, if color-aware is set to enable and no values are specified (that is, the no form of the command is used in the profile), the CLI gives an error. If values are specified, then the configured values are used to match and identify in-profile and out-of-profile packets.

The no form of the command disables the use of dot1p to identify a green or yellow packet.

**Note:** Testhead OAM tool does not mark the packets below CIR as in-profile packets and packets above CIR and below PIR as out-of-profile packets using the Dot1p or DSCP or other packet header bits to indicate the color of the packet (for example: DEI bit), as the 7210 SAS access SAP ingress does not support color-aware metering. It is used to only identify green and yellow packets and maintain a count of received green and yellow packets when the tests are run in color-aware mode.

**Default** The no form of this command is the default. There are no defaults for the dot1p values.

**Parameters** *in-profile dot1p-value* — Specifies the dot1p value used to identify green or in-profile packets. It must be different than the value configured for yellow or out-of-profile packets.

**Values** 0-7

*out-profile dot1p-value* — Specifies the dot1p value used to identify green or out-of-profile packets. It must be different than the value configured for green or in-profile packets.

**Values** 0-7

## frame-payload

**Syntax** **[no] frame-payload** *frame-payload-id* [**payload-type** [I2|tcp-ipv4|udp-ipv4|ipv4] **create**

**Context** configure> test-oam> testhead-profile

**Description** This command provides the context to specify the packet header values to be used in frames generated by testhead tool.

User can create up to 4 different types of frame payload representing different kinds of traffic, within a profile. User chooses one among these when starting the throughput test.

The parameter payload-type determines the packet header fields that are used to populate the frame generated by the testhead OAM tool. The packet header fields use the value from the parameters configured under the frame-payload. For example, when the payload-type is configured as "I2", software uses the parameters src-mac, dst-mac, vlan-tag-1 (if configured), vlan-tag-2 (if configured), ethertype, and data-pattern. See below for parameters used when other values are specified with payload-type.

The no form of the command removes the frame payload context.

**Default** no defaults – no frame payload is created by default.

**Parameters** *frame-payload-id* — A number to identify the frame-payload. it is an integer used to identify the frame type to use when starting the throughput test.

**Values** 1-4

*frame-payload-type* — Identifies whether the frame payload is L2 traffic, IP traffic, TCP/IP traffic or UDP/IP traffic and uses appropriate parameters to build the frame to be generated by the testhead OAM tool. It defaults to tcp-ipv4, if the user does not specify the value during creation of the new frame-payload.

**Values** l2|tcp-ipv4|udp-ipv4|ipv4  
 If l2 is specified, use src-mac+dst-mac+vlan-tag-1(if available)+vlan-tag-2 (if available)+ethertype+data-pattern.  
 If tcp-ipv4 or udp-ipv4 is specified, use src-mac+dst-mac+vlan-tag-1(if available)+vlan-tag-2 (if available)+ethertype=0x0800+src-ipv4+dst-ipv4+ip-ttl+ip-dscp or ip-tos+TCP/UDP Protocol Number+src-port+dst-port+data-pattern.  
 If ipv4 is specified, use src-mac+dst-mac+vlan-tag-1(if available)+vlan-tag-2 (if available)+ethertype=0x0800+src-ipv4+dst-ipv4+ip-ttl+ip-dscp or ip-tos+ip-proto+data-pattern.

## description

**Syntax** [no] **description** *frame-description*

**Context** configure> test-oam> testhead-profile> frame-payload

**Description** This command allows user to add some description to the frame type created to describe the purpose or identify the usage or any other such purpose.

The no form of the command removes the description.

**Default** no description

**Parameters** *frame-description* — it is an ASCII string used to describe the frame.

**Values** ASCII string

## src-mac

**Syntax** [no] **src-mac** *mac-address*

**Context** configure> test-oam> testhead-profile> frame-payload

**Description** Specifies the value of source MAC address to use in the frame generated by the testhead OAM tool. Only unicast MAC address must be specified.

This value must be specified for all possible values of payload-type.

The no form of the command indicates that the field is not to be used in the frame generated by the tool.

**Default** no src-mac

## Operational Commands

**Parameters** *mac-address* — Specify the unicast source MAC address.

**Values** It is specified as a hexadecimal string using the notation xx:xx:xx:xx:xx:xx. The values for xx can be in the range 0-9 and a-f.

### dst-mac

**Syntax** **[no] dst-mac** *mac-address*

**Context** configure> test-oam> testhead-profile> frame-payload

**Description** Specifies the value of source MAC address to use in the frame generated by the testhead OAM tool. Only unicast MAC address must be specified.

This value must be specified for all possible values of payload-type.

The no form of the command indicates that the field is not to be used in the frame generated by the tool.

**Default** no dst-mac

**Parameters** *mac-address* — Specify the unicast source MAC address.

**Values** It is specified as a hexadecimal string using the notation xx:xx:xx:xx:xx:xx. The values for xx can be in the range 0-9 and a-f.

### vlan-tag-1

**Syntax** **[no] vlan-tag-1** **vlan-id** *vlan-id-value* **[tpid** *tpid value* **]** **[dot1p** *dot1p-value* **]**

**Context** configure> test-oam> testhead-profile> frame-payload

**Description** This command allows the user to specify the values to be used for the outermost vlan-tag (often called the outer vlan) in the frame generated by the testhead OAM tool. The tool uses the values specified for VLAN ID, dot1p bits and TPID in populating the outermost VLAN tag in the frame generated.

Configuration of this parameter is optional and it is used for all possible values of payload-type, if configured.

The no form of the command indicates that the field is not to be used in the frame generated by the tool.

NOTES:

- User must ensure that TPID/ethertype configured with this command matches the QinQ ethertype value in use on the port on which the test SAP is configured or must match 0x8100 if the test SAP is configured on a Dot1q encapsulation port, for the frame generated by the tool to be processed successfully on SAP ingress. If this value does not match the one configured under the port, frames generated by the testhead will be dropped by the node on SAP ingress due to ethertype mismatch.
- User must ensure that VLAN ID configured with this command matches the outermost VLAN tag of the QinQ SAP or the Dot1q SAP used for the test SAP for the frame generated by the tool to be processed successfully on SAP ingress. If this value does not match the one configured for the SAP,

frames generated by the testhead will be dropped by the node on SAP ingress due to VLAN ID mismatch.

- The Dot1p bits specified for the outermost tag can be used for SAP ingress QoS classification.

**Default** no vlan-tag-1

**Parameters** *vlan-id-value* — Specify the VLAN ID to use to populate the VLAN ID value of the VLAN tag. No defaults are chosen and user has to specify a value to use, if they configure this command.

**Values** Values can be in the range 0-4094.

*tpid-value* — Specify the TPID (also known as, ethertype) to use for the VLAN tag addition. It defaults to 0x8100 if user does not specify it.

**Values** Values can be any of the valid ethertype values allowed for use with VLAN tags in the range 0x0600..0xffff.

*Dot1p-value* — Specify the Dot1p value to use to populate the Dot1p bits in the VLAN tag. It defaults to 0, if the user does not specify it.

**Values** Values can be in the range of 0 – 7.

## vlan-tag-2

**Syntax** **[no] vlan-tag-2 vlan-id *vlan-id-value* [tpid *tpid value*] [dot1p *dot1p-value*]**

**Context** configure> test-oam> testhead-profile> frame-payload

**Description** This command allows the user to specify the values to be used for the second vlan-tag (often called the inner vlan or the C-vlan) in the frame generated by the testhead OAM tool. The tool uses the values specified for VLAN ID, dot1p bits and TPID in populating the second VLAN tag in the frame generated.

Configuration of this parameter is optional and it is used for all possible values of payload-type, if configured.

The no form of the command indicates that the field is not to be used in the frame generated by the tool.

### NOTES:

- User must ensure that TPID/ethertype configured with this command is 0x8100 for the frame generated by the tool to be processed successfully on SAP ingress. If this value does not match 0x8100, frames generated by the testhead will be dropped by the node on SAP ingress due to ethertype mismatch (7210 supports only 0x8100 as the ethertype value for the inner vlan tag).
- User must ensure that VLAN ID configured with this command matches the outermost VLAN tag of the QinQ SAP or the Dot1q SAP used for the test SAP for the frame generated by the tool to be processed successfully on SAP ingress. If this value does not match the one configured for the SAP, frames generated by the testhead will be dropped by the node on SAP ingress due to VLAN ID mismatch.
- The Dot1p bits specified for the outermost tag can be used for SAP ingress QoS classification.

**Default** no vlan-tag-2

## Operational Commands

**Parameters** *vlan-id-value* — Specify the VLAN ID to use to populate the VLAN ID value of the VLAN tag. No defaults are chosen and user has to specify a value to use, if they configure this command.

**Values** Values can be in the range 0-4094.

*tpid-value* — Specify the TPID (also known as, ether-type) to use for the VLAN tag addition. It defaults to 0x8100 if user does not specify it.

**Values** Values can be any of the valid ether-type values allowed for use with VLAN tags in the range 0x0600..0xffff.

*Dot1p-value* — Specify the Dot1p value to use to populate the Dot1p bits in the VLAN tag. It defaults to 0, if the user does not specify it.

**Values** Values can be in the range of 0 – 7

## ether-type

**Syntax** **[no] ether-type ether-type-value**

**Context** configure> test-oam> testhead-profile> frame-payload

**Description** This command allows the user to specify the ether-type of the frame generated by the testhead tool.

This value must be specified if the payload-type is “l2”. The testhead tool uses the value specified with this command only if the payload-type is “l2”. For all other values of payload-type, the ether-type value used in the frame generated by the testhead tool uses specific value based on the payload-type. See the frame-payload CLI description for more information.

The no form of the command indicates that the field is not to be used in the frame generated by the tool.

**Default** no ether-type, if the payload-type is set to l2, else the values used depends on the payload-type specified.

**Parameters** *ether-type-value* — Specify the frame payload ether-type value.

**Values** Valid ether-type values specified in the range 0x0600..0xffff, as hexadecimal string.

## src-ip

**Syntax** **[no] src-ip ipv4 ipv4-address**

**Context** configure> test-oam> testhead-profile> frame-payload

**Description** This command allows the user to specify the source IPv4 address to use in the IP header for the frame generated by the testhead tool.

This value must be specified if the payload-type is configured as ipv4 or tcp-ipv4 or udp-ipv4. The testhead tool does not use the value specified with this command if the payload-type is “l2”.

The no form of the command indicates that the field is not to be used in the frame generated by the tool.

**Default** no src-ip, if the payload-type is set to ipv4, tcp-ipv4, udp-ipv4.

**Parameters** *ipv4-address* — Specify the IPv4 source IP address to use in the IP header

**Values** Valid IPv4 address specified in dotted decimal format (that is, a.b.c.d) where a, b, c, d are decimal values in the range1-255

## dst-ip

**Syntax** **[no] dst-ip ipv4** *ipv4-address*

**Context** configure> test-oam> testhead-profile> frame-payload

**Description** This command allows the user to specify the destination IPv4 address to use in the IP header for the frame generated by the testhead tool.

This value must be specified if the payload-type is configured as ipv4 or tcp-ipv4 or udp-ipv4. The testhead tool does not use the value specified with this command if the payload-type is “12”.

The no form of the command indicates that the field is not to be used in the frame generated by the tool.

**Default** no dst-ip, if the payload-type is set to ipv4, tcp-ipv4, udp-ipv4.

**Parameters** *ipv4-address* — Specify the IPv4 destination IP address to use in the IP header

**Values** Valid IPv4 address specified in dotted decimal format (that is, a.b.c.d) where a, b, c, d are decimal values in the range1-255.

## ip-proto

**Syntax** **[no] ip-proto** *ip-protocol-number*

**Context** configure> test-oam> testhead-profile> frame-payload

**Description** This command allows the user to specify the IP protocol value to use in the IP header for the frame payload generated by the testhead tool.

This value must be specified if the payload-type is configured as ipv4. If the payload-type is specified as tcp-ipv4 or udp-ipv4, the appropriate standard defined values are used. The testhead tool does not use the value specified with this command if the payload-type is “12”.

The no form of the command indicates that the field is not to be used in the frame generated by the tool.

**Default** no ip-proto

**Parameters** *ip-protocol-number* — Specify the IP-protocol number to use in the IP header.

**Values** Valid IP protocol number specified as a decimal number in the range 0-255.

## Operational Commands

### dscp

**Syntax** [no] dscp *dscp-name*

**Context** configure> test-oam> testhead-profile> frame-payload

**Description** This command allows the user to specify the IP DSCP value to use in the IP header for the frame generated by the testhead tool.

This value can be specified if the payload-type is configured as ipv4 or tcp-ipv4 or udp-ipv4 and if configured is used by the testhead tool to populate the IP DSCP field of the IP header. If it is not specified it defaults to 0 when the payload type is ipv4, tcp-ipv4, and udp-ipv4. The testhead tool does not use the value specified with this command if the payload-type is "l2".

**NOTES:**

- If both IP DSCP and IP ToS is configured them IP DSCP take precedence.
- If IP DSCP is not configured but IP ToS is configured, then IP ToS value is used.

The no form of the command indicates that the field is not to be used in the frame generated by the tool.

**Default** no dscp

**Parameters** *dscp-name* — Specify the IPv4 DSCP value to use in the IP header.

**Values** Valid values from the list of DSCP names.  
be|ef|cp1|cp2|cp3|cp4|cp5|cp6|cp7|cp9|cs1|cs2|cs3|cs4|cs5|nc1|nc2|af11|af12|af13|af21|af22|af23|af31|af32|af33|af41|af42|af43|cp11|cp13|cp15|cp17|cp19|cp21|cp23|cp25|cp27|cp29|cp31|cp33|cp35|cp37|cp39|cp41|cp42|cp43|cp44|cp45|cp47|cp49|cp50|cp51|cp52|cp53|cp54|cp55|cp57|cp58|cp59|cp60|cp61|cp62|cp63

### ip-ttl

**Syntax** [no] ip-ttl *tll-value*

**Context** configure> test-oam> testhead-profile> frame-payload

**Description** This command allows the user to specify the IP TTL (Time-to-Live) value to use in the IP header for the frame generated by the testhead tool.

This value can be specified if the payload-type is configured as ipv4 or tcp-ipv4 or udp-ipv4 and if configured is used by the testhead tool to populate the IP TTL field of the IP header. If it is not specified it defaults to 1 when the payload type is ipv4, tcp-ipv4, and udp-ipv4. The testhead tool does not use the value specified with this command if the payload-type is "l2".

The no form of the command indicates that the field is not to be used in the frame generated by the tool.

**Default** no ip-ttl

**Parameters** *tll-value* — Specify the IP TTL value to use in the IP header.

**Values** Specified as a decimal number in the range 1-255.

## ip-tos

**Syntax** [no] ip-tos *type-of-service*

**Context** configure> test-oam> testhead-profile> frame-payload

**Description** This command allows the user to specify the IP TOS (Type of Service) value to use in the IP header for the frame generated by the testhead tool.

This value can be specified if the payload-type is configured as ipv4 or tcp-ipv4 or udp-ipv4 and if configured is used by the testhead tool to populate the IP TOS field of the IP header. If it is not specified it defaults to 0 when the payload type is ipv4, tcp-ipv4, and udp-ipv4. The testhead tool does not use the value specified with this command if the payload-type is "l2".

**NOTES:**

- If both IP DSCP and IP ToS is configured them IP DSCP take precedence.
- If IP DSCP is not configured but IP ToS is configured, then IP ToS value is used.

The no form of the command indicates that the field is not to be used in the frame generated by the tool.

**Default** no ip-tos

**Parameters** *type-of-service* — Specify the value of ToS bits to use in the IP header.

**Values** Valid number in the range 0-8.

## src-port

**Syntax** [no] src-port *src-port-number*

**Context** configure> test-oam> testhead-profile> frame-payload

**Description** This command allows the user to specify the source port to use in the TCP header for the frame generated by the testhead tool.

This value must be specified if the payload-type is configured as tcp-ipv4 or udp-ipv4. The testhead tool does not use the value specified with this command if the payload-type is l2 or ipv4.

The no form of the command indicates that the field is not to be used in the frame generated by the tool.

**Default** no src-port, if the payload-type is set to tcp-ipv4 or udp-ipv4

**Parameters** *src-port-number* — Specify the source TCP/UDP port number to use in the frame's TCP/UDP header.

**Values** Valid TCP/UDP port number specified in decimal or hexadecimal in the range 0-65535.

## dst-port

<b>Syntax</b>	<b>[no] dst-port</b>
<b>Context</b>	configure> test-oam> testhead-profile> frame-payload
<b>Description</b>	<p>This command allows the user to specify the destination port to use in the TCP header for the frame generated by the testhead tool.</p> <p>This value must be specified if the payload-type is configured as tcp-ipv4 or udp-ipv4. The testhead tool does not use the value specified with this command if the payload-type is l2 or ipv4.</p> <p>The no form of the command indicates that the field is not to be used in the frame generated by the tool.</p>
<b>Default</b>	no dst-port, if the payload-type is set to tcp-ipv4 or udp-ipv4
<b>Parameters</b>	<i>dst-port-number</i> — Specify the destination TCP/UDP port number to use in the frame's TCP/UDP header.
<b>Values</b>	Valid TCP/UDP port number specified in decimal or hexadecimal in the range 0-65535.

## data-pattern

<b>Syntax</b>	<b>[no] data-pattern <i>data-pattern</i></b>
<b>Context</b>	configure> test-oam> testhead-profile> frame-payload
<b>Description</b>	<p>This command allows the user to specify the data pattern to populate the payload portion of the frame generated by the testhead tool.</p> <p>This value can be specified if the payload-type is configured as l2 or ipv4 or tcp-ipv4 or udp-ipv4. For all these payload types, the frame with the appropriate headers is created and the payload portion of the frame, is filled up with the data-pattern-value specified with this command, repeating it as many times as required to fill up the remaining length of the payload.</p> <p>The no form of the command uses the default data-pattern value of 0xa1b2c3d4e5f6.</p>
<b>Default</b>	no data-pattern
<b>Parameters</b>	<i>data-pattern</i> — Used to specify the data-pattern to fill the payload data.
<b>Values</b>	A string of decimal or hexadecimal numbers of length in the range 1-64.

---

## OAM testhead commands

### testhead

**Syntax** `testhead test-name owner owner-name testhead-profile profile-id [frame-payload frame-payload-id] [acceptance-criteria acceptance-criteria-id] [color-aware enable|disable] sap sap-id [fc fc-name]`

**Context** oam

**Description** This command allows the user to execute the throughput test by generating the traffic up to the configured rate and measures the delay, delay-variation and frame-loss ratio. At the end of the test run the testhead command compares the measured values against the test acceptance criteria that is specified to determine if the service is within bounds of the acceptance criteria or not. It declares the test to have PASSED if the configured rate thresholds are achieved and the measured performance parameters (that is, latency, jitter, and FLR) values are lesser than the thresholds configured in the acceptance criteria. It reports a FAILURE, if the configured rate thresholds are not achieved or if any of the measured values for the performance parameters exceeds the thresholds configured in the acceptance criteria.

The user must specify the testhead-profile parameter to use. This profile parameter determines the rate at which traffic is generated and the content of the frames used for traffic generation. If both CIR and PIR is specified or if only PIR is specified (by setting CIR to zero), the tool generates traffic up to the configured PIR rate. If only CIR is specified the tool generates traffic up to the configured CIR rate.

If the acceptance-criteria parameter is not specified and color-aware is set to disable, then by default software will display the test result as "PASS", if the frame loss is zero and desired rate is achieved. For comparison with measured rate, the test uses the configured CIR rate, if only CIR is configured or it uses the PIR rate, if either only PIR rate is specified or if both CIR and PIR rates are set to non-zero values. Measured value of latency, jitter and delay variation is not compared.

If the acceptance-criteria parameter is not specified and color-aware is set to enable, then the test is declared to be pass, if the measured CIR and PIR rates matches the configured CIR and PIR values and frame loss is zero OR if one of the following is true:

- If the measured throughput rate (CIR + PIR) is equal to the configured CIR rate and if no PIR rate is configured.
- If the measured throughput rate (CIR + PIR) is equal to the configured PIR rate and if either no CIR rate is configured or if CIR rate is configured.

The test is declared to 'FAIL' otherwise. Measured value of latency, jitter, and delay variation is not compared.

If acceptance-criteria is specified and color-aware is set to enable, the test will use the configured packet header marking values (that is, dot1p) to identify the color of the packet and classify it as green (in-profile) or yellow (out-of-profile). It measures the green packet (that is, CIR rate) and the green/in-profile packet performance parameter values and the yellow packet rate (that is, PIR rate) and the yellow/out-of-profile packet performance parameter values individually based on the packet markings. In addition to comparing the measured performance parameter values against the normal performance parameter threshold values (if enabled), if user has enabled in/out thresholds for performance parameters in the acceptance-criteria, the tool will use these values to compare against the measured values and declare a pass/fail result. The tool uses the

## OAM testhead commands

*cir-threshold* and *pir-threshold* to compare against the measured CIR and PIR throughput rates and declare PASS/FAIL, if the thresholds specified by the *cir-threshold* and *pir-threshold* are achieved.

**NOTE:** When color-aware mode is set to enable, the marking values used to identify both in-profile/green packet and out-of-profile/yellow packet must be configured. If either of the packet header marking values (For example: dot1p) are not configured by the user, then the CLI displays an error.

If acceptance-criteria is specified and color-aware is set to disable, the tests are color blind (not color-aware). The tool does not use the configured packet header marking values to identify the color of the packet and treats all packets the same. The tool uses the normal thresholds configured in the acceptance-criteria (i.e. the threshold values other than the in/out profile thresholds) to compare the measured values and declare a pass/fail result. The tool will not make any attempt to compare the in/out thresholds against measured values. The tool uses the *cir-threshold* and *pir-threshold* as follows:

- If no PIR rate is configured and if the measured throughput rate is equal to the configured *cir-threshold* rate, the desired rate is said to have been achieved and the tests continue to compare the measured performance parameter thresholds with the configured performance parameter thresholds (if any).
- If PIR rate is configured and no CIR rate is configured and if the measured throughput rate is equal to the configured *pir-threshold* rate, the desired rate is said to have been achieved and the tests continue to compare the measured performance parameter thresholds with the configured performance parameter thresholds (if any).
- If PIR rate is configured and CIR rate is configured and if the measured throughput rate is equal to the configured *pir-threshold* rate, the desired rate is said to have been achieved and the tests continue to compare the measured performance parameter thresholds with the configured performance parameter thresholds (if any).

The test-name and owner-name together identify a particular testhead invocation/session uniquely. The results of the testhead session are associated with the test-name and owner-name. These parameters must be used if the user needs to display the results of the testhead tool and to clear the results of a completed run. Multiple invocations of the testhead tool with the same test-name and owner-name is not allowed if the results of the old run using the same pair of test-name and owner-name are present. In other words, the results are not overwritten when the testhead is invoked again with the same values for test-name and owner-name. The results needs to be cleared explicitly using the clear command before invoking the testhead tool with the same test-name and owner-name. Results for up to 100 unique sessions each using a different test-name and owner-name is saved in memory (in other words, the results are not available for use after a reboot).

**NOTE:** This command is not saved in the configuration file across a reboot.

For more information, See the, “Pre-requisites for using the Testhead Tool on page 152”

**Default** no defaults

**Parameters** *test-name* — Name of the test

**Values** ASCII string upto 32 characters in length

*owner test-owner* — Specifies the owner of an testhead operation.

**Values** ASCII string upto 32 characters in length

*testhead-profile profile-id* — Specifies the testhead profile ID to use with this run/session of testhead invocation. Testhead profile must be configured beforehand using the commands under `config> test-oam> test-head-profile>`.

**Values** 1- 10

*frame-payload frame-payload-id* — Optional parameter used to specify the frame payload ID to use for this run. It identifies the parameters used to construct the frame generated by the testhead tool.

**Values** 1 – 4, if this parameter is not specified, then by default parameters configured under `frame-payload-id 1` is used by this run.

*acceptance-criteria acceptance-criteria-id* — Optional parameter used to specify the test acceptance criteria parameters to use. for this run. It identifies the parameters used to compare the measured performance values against the configured thresholds configured in the acceptance criteria.

**Values** 1 – 4. If this parameter is not specified then the run is declared pass if the throughput configured in the testhead-profile is achieved without any loss.

*color-aware* — Optional parameter that specifies if color aware tests need to be executed. If set to enable, then color-aware test enabled. If set to disable, which is the default, then non-color-ware test is enabled.

*sap sap-id* — Identifies the test SAP. Must be specified by the user.

**Values** null - <port-id|lag-id>  
 dot1q - <port-id|lag-id>:qtag1  
 QinQ - <port-id|lag-id>:qtag1.qtag2  
 port-id - slot/mda/port  
 lag-id - lag-<id>  
 lag - keyword  
 id - [1..200]  
 qtag1 - [0..4094]  
 qtag2 - [\*|1..4094]

For more information, see “SAP configuration guidelines”.

*fc fc-name* — Optional parameter that specifies the forwarding class (FC) to use to send the frames generated by the testhead tool.

**Values** be, l2, af, l1, h2, ef, h1, nc

## testhead

**Syntax** `testhead test-name owner owner-name stop`

**Context** oam

**Description** The currently running test, if any will be stopped. All performance results based on the data available upto the time the test is stopped is used determine the pass/fail criteria. Additionally, the test-status will display “Stopped” and Test completion status will be marked “Incomplete or No”.

## OAM testhead commands

**Parameters**    *test-name* — Name of the test

**Values**        ASCII string upto 32 characters in length

*owner test-owner* — Specifies the owner of an testhead operation.

**Values**        ASCII string upto 32 characters in length

---

## Service Assurance Agent (SAA) Commands

### saa

**Syntax**    **saa**

**Context**    config

**Description**    This command creates the context to configure the Service Assurance Agent (SAA) tests.

### test

**Syntax**    **test** *name* [**owner** *test-owner*]  
**no test** *name*

**Context**    config>saa

**Description**    This command identifies a test and create/modify the context to provide the test parameters for the named test. Subsequent to the creation of the test instance the test can be started in the OAM context.

A test can only be modified while it is shut down.

The **no** form of this command removes the test from the configuration. In order to remove a test it can not be active at the time.

**Parameters**    *name* — Identify the saa test name to be created or edited.

**owner** *test-owner* — Specifies the owner of an SAA operation upto 32 characters in length.

**Values**        If a *test-owner* value is not specified, tests created by the CLI have a default owner “TIMOS CLI”.

### accounting-policy

**Syntax**    **accounting-policy** *acct-policy-id*  
**no accounting-policy**

**Context**    config>saa>test

**Description**    This command associates an accounting policy to the SAA test. The accounting policy must already be defined before it can be associated else an error message is generated.

A notification (trap) when a test is completed is issued whenever a test terminates.

The **no** form of this command removes the accounting policy association.

**Default**    none

## OAM testhead commands

**Parameters** *acct-policy-id* — Enter the accounting *policy-id* as configured in the **config>log>accounting-policy** context.  
**Values** 1 — 99

## description

**Syntax** **description** *description-string*  
**no description**

**Context** config>saa>test

**Description** This command creates a text description stored in the configuration file for a configuration context. The **description** command associates a text string with a configuration context to help identify the content in the configuration file. The **no** form of this command removes the string from the configuration.

**Default** No description associated with the configuration context.

**Parameters** *string* — The description character string. Allowed values are any string up to 80 characters long composed of printable, 7-bit ASCII characters. If the string contains special characters (#, \$, spaces, etc.), the entire string must be enclosed within double quotes.

## continuous

**Syntax** [**no**] **continuous**

**Context** config>saa>test

**Description** This command specifies whether the SAA test is continuous. Once the test is configured as continuous, it cannot be started or stopped by using the **saa** command. The **no** form of the command disables the continuous running of the test. Use the **shutdown** command to disable the test.

## jitter-event

**Syntax** **jitter-event rising-threshold** *threshold* [**falling-threshold** *threshold*] [**direction**]  
**no jitter-event**

**Context** config>saa>test

**Description** Specifies that at the termination of an SAA test probe, the calculated jitter value is evaluated against the configured rising and falling jitter thresholds. SAA threshold events are generated as required. Once the threshold (rising/falling) is crossed, it is disabled from generating additional events until the opposite threshold is crossed. If a falling-threshold is not supplied, the rising threshold will be re-enabled when it falls below the threshold after the initial crossing that generate the event.

The configuration of jitter event thresholds is optional.

<b>Parameters</b>	<b>rising-threshold</b> <i>threshold</i> — Specifies a rising threshold jitter value. When the test run is completed, the calculated jitter value is compared to the configured jitter rising threshold. If the test run jitter value is greater than the configured rising threshold value then an SAA threshold event is generated. The SAA threshold event is <code>tmnxOamSaaThreshold</code> , logger application OAM, event #2101.
	<p><b>Default</b> 0</p> <p><b>Values</b> 0 — 2147483 milliseconds</p>
	<b>falling-threshold</b> <i>threshold</i> — Specifies a falling threshold jitter value. When the test run is completed, the calculated jitter value is compared to the configured jitter falling threshold. If the test run jitter value is greater than the configured falling threshold value then an SAA threshold event is generated. The SAA threshold event is <code>tmnxOamSaaThreshold</code> , logger application OAM, event #2101.
	<p><b>Default</b> 0</p> <p><b>Values</b> 0 — 2147483 milliseconds</p>
	<i>direction</i> — Specifies the direction for OAM ping responses received for an OAM ping test run.
	<p><b>Values</b> <b>inbound</b> — Monitor the value of jitter calculated for the inbound, one-way, OAM ping responses received for an OAM ping test run.</p> <p><b>outbound</b> — Monitor the value of jitter calculated for the outbound, one-way, OAM ping requests sent for an OAM ping test run.</p> <p><b>roundtrip</b> — Monitor the value of jitter calculated for the round trip, two-way, OAM ping requests and replies for an OAM ping test run.</p>
	<b>Default</b> roundtrip

## latency-event

<b>Syntax</b>	<b>latency-event rising-threshold</b> <i>threshold</i> [ <b>falling-threshold</b> <i>threshold</i> ] [ <b>direction</b> ] <b>no latency-event</b>
<b>Context</b>	config>saa>test
<b>Description</b>	<p>Specifies that at the termination of an SAA test probe, the calculated latency event value is evaluated against the configured rising and falling latency event thresholds. SAA threshold events are generated as required.</p> <p>Once the threshold (rising/falling) is crossed, it is disabled from generating additional events until the opposite threshold is crossed. If a falling-threshold is not supplied, the rising threshold will be re-enabled when it falls below the threshold after the initial crossing that generate the event.</p> <p>The configuration of latency event thresholds is optional.</p>
<b>Parameters</b>	<b>rising-threshold</b> <i>threshold</i> — Specifies a rising threshold latency value. When the test run is completed, the calculated latency value is compared to the configured latency rising threshold. If the test run latency value is greater than the configured rising threshold value then an SAA threshold event is generated. The SAA threshold event is <code>tmnxOamSaaThreshold</code> , logger application OAM, event #2101.
	<b>Default</b> 0
	<b>Values</b> 0 — 2147483 milliseconds

## OAM testhead commands

**falling-threshold** *threshold* — Specifies a falling threshold latency value. When the test run is completed, the calculated latency value is compared to the configured latency falling threshold. If the test run latency value is greater than the configured falling threshold value then an SAA threshold event is generated. The SAA threshold event is `tmnxOamSaaThreshold`, logger application OAM, event #2101.

**Default** 0

**Values** 0 — 2147483 milliseconds

*direction* — Specifies the direction for OAM ping responses received for an OAM ping test run.

**Values** **inbound** — Monitor the value of jitter calculated for the inbound, one-way, OAM ping responses received for an OAM ping test run.

**outbound** — Monitor the value of jitter calculated for the outbound, one-way, OAM ping requests sent for an OAM ping test run.

**roundtrip** — Monitor the value of jitter calculated for the round trip, two-way, OAM ping requests and replies for an OAM ping test run.

**Default** roundtrip

## loss-event

**Syntax** **loss-event rising-threshold** *threshold* [**falling-threshold** *threshold*] [**direction**]  
**no loss-event**

**Context** config>saa>test

**Description** Specifies that at the termination of an SAA testrun, the calculated loss event value is evaluated against the configured rising and falling loss event thresholds. SAA threshold events are generated as required.

The configuration of loss event thresholds is optional.

**Parameters** **rising-threshold** *threshold* — Specifies a rising threshold loss event value. When the test run is completed, the calculated loss event value is compared to the configured loss event rising threshold. If the test run loss event value is greater than the configured rising threshold value then an SAA threshold event is generated. The SAA threshold event is `tmnxOamSaaThreshold`, logger application OAM, event #2101.

**Default** 0

**Values** 0 — 2147483647 packets

**falling-threshold** *threshold* — Specifies a falling threshold loss event value. When the test run is completed, the calculated loss event value is compared to the configured loss event falling threshold. If the test run loss event value is greater than the configured falling threshold value then an SAA threshold event is generated. The SAA threshold event is `tmnxOamSaaThreshold`, logger application OAM, event #2101.

**Default** 0

**Values** 0 — 2147483647 packets

*direction* — Specifies the direction for OAM ping responses received for an OAM ping test run.

**Values** **inbound** — Monitor the value of jitter calculated for the inbound, one-way, OAM ping responses received for an OAM ping test run.

**outbound** — Monitor the value of jitter calculated for the outbound, one-way, OAM ping requests sent for an OAM ping test run.

**roundtrip** — Monitor the value of jitter calculated for the round trip, two-way, OAM ping requests and replies for an OAM ping test run.

**Default** roundtrip

## probe-history

**Syntax** **probe-history [auto | drop | keep]**

**Context** config>saa>test

**Description** Defines history probe behavior. Defaults are associated with various configured parameters within the SAA test. Auto (keep) is used for test with probe counts of 100 or less, and intervals of 1 second and above. Auto (drop) will only maintain summary information for tests marked as continuous with file functions, probe counts in excess of 100 and intervals of less than 1 second. SAA tests that are not continuous with a write to file will default to Auto (keep). The operator is free to change the default behaviors for each type. Each test that maintains per probe history will consume more system memory. When per probe entries are required the probe history is available at the completion of the test.

**Default** auto

**Parameters** *auto* — An auto selector that determines the storage of the history information.

*drop* — Store summarized min/max/ave data not per probe information for test runs. This may be configured for all tests in an effort to conserve memory.

*keep* — Store per probe information for tests. This consumes significantly more memory than summary information and should only be used if necessary.

## trap-gen

**Syntax** **trap-gen**

**Context** config>saa>test

**Description** This command enables the context to configure trap generation for the SAA test.

## probe-fail-enable

**Syntax** **[no] probe-fail-enable**

**Context** config>saa>test>trap-gen

**Description** This command enables the generation of an SNMP trap when probe-fail-threshold consecutive probes fail during the execution of the SAA ping test. This command is not applicable to SAA trace route tests.

The **no** form of the command disables the generation of an SNMP trap.

## probe-fail-threshold

**Syntax** [no] **probe-fail-threshold** *threshold*

**Context** config>saa>test>trap-gen

**Description** This command has no effect when probe-fail-enable is disabled. This command is not applicable to SAA trace route tests.

The **probe-fail-enable** command enables the generation of an SNMP trap when the probe-fail-threshold consecutive probes fail during the execution of the SAA ping test. This command is not applicable to SAA trace route tests.

The **no** form of the command returns the threshold value to the default.

**Default** 1

## test-completion-enable

**Syntax** [no] **test-completion-enable**

**Context** config>saa>test>trap-gen

**Description** This command enables the generation of a trap when an SAA test completes.

The **no** form of the command disables the trap generation.

## test-fail-enable

**Syntax** [no] **test-fail-enable**

**Context** config>saa>test>trap-gen

**Description** This command enables the generation of a trap when a test fails. In the case of a ping test, the test is considered failed (for the purpose of trap generation) if the number of failed probes is at least the value of the **test-fail-threshold** parameter.

The **no** form of the command disables the trap generation.

## test-fail-threshold

**Syntax** [no] **test-fail-threshold** *threshold*

**Context** config>saa>test>trap-gen

**Description** This command configures the threshold for trap generation on test failure.

This command has no effect when test-fail-enable is disabled. This command is not applicable to SAA trace route tests.

The **no** form of the command returns the threshold value to the default.

**Default** 1

## type

**Syntax** **type**  
**no type**

**Context** config>saa>test

**Description** This command creates the context to provide the test type for the named test. Only a single test type can be configured.

A test can only be modified while the test is in shut down mode.

Once a test type has been configured the command can be modified by re-entering the command, the test type must be the same as the previously entered test type.

To change the test type, the old command must be removed using the **config>saa>test>no type** command.

## cpe-ping

**Note:** This command is not supported on 7210 SAS-M and 7210 SAS-T devices configured in Access uplink mode. Only on the devices configured in Network mode.

**Syntax** **cpe-ping service** *service-id* **destination** *ip-address* **source** *ip-address* [*ttl vc-label-ttl*] [**return-control**] [**source-mac** *ieee-address*] [**fc** *fc-name*] [**interval** *interval*] [**send-count** *send-count*] [**send-control**]

**Context** oam  
config>saa>test>type

**Description** This ping utility determines the IP connectivity to a CPE within a specified VPLS service.

**Parameters** **service** *service-id* — The service ID of the service to diagnose or manage.

**Values** *service-id:* 1 — 2147483647  
*svc-name:* 64 characters maximum

**destination** *ip-address* — Specifies the IP address to be used as the destination for performing an OAM ping operations.

**source** *ip-address* — Specify an unused IP address in the same network that is associated with the VPLS.

**ttl** *vc-label-ttl* — The TTL value in the VC label for the OAM MAC request, expressed as a decimal integer.

**Default** 255

**Values** 1 — 255

**return-control** — Specifies the MAC OAM reply to a data plane MAC OAM request be sent using the control plane instead of the data plane.

## OAM testhead commands

**Default** MAC OAM reply sent using the data plane.

**source-mac** *ieee-address* — Specify the source MAC address that will be sent to the CPE. If not specified or set to 0, the MAC address configured for the CPMCFM is used.

**fc-name** — The forwarding class of the MPLS echo request encapsulation.

**Default** be

**Values** be, l2, af, l1, h2, ef, h1, nc

**interval** *interval* — The **interval** parameter in seconds, expressed as a decimal integer. This parameter is used to override the default request message send interval and defines the minimum amount of time that must expire before the next message request is sent.

If the **interval** is set to 1 second where the **timeout** value is set to 10 seconds, then the maximum time between message requests is 10 seconds and the minimum is 1 second. This depends upon the receipt of a message reply corresponding to the outstanding message request.

**Default** 1

**Values** 1 — 10

**send-count** *send-count* — The number of messages to send, expressed as a decimal integer. The **count** parameter is used to override the default number of message requests sent. Each message request must either timeout or receive a reply before the next message request is sent. The message **interval** value must be expired before the next message request is sent.

**Default** 1

**Values** 1 — 255

**send-control** — Specifies the MAC OAM request be sent using the control plane instead of the data plane.

**Default** MAC OAM request sent using the data plane.

## dns

**Syntax** **dns target-addr** *dns-name* **name-server** *ip-address* [**source** *ip-address*] [**send-count** *send-count*] [**timeout** *timeout*] [**interval** *interval*] [**record-type** {**ipv4-a-record** | **ipv6-aaaa-record**}]

**Context** <GLOBAL>  
config>saa>test>type

**Description** This command configures a DNS name resolution test.

**Parameters** **target-addr** — The IP host address to be used as the destination for performing an OAM ping operation. *dns-name* — The DNS name to be resolved to an IP address.

**name-server** *ip-address* — Specifies the server connected to a network that resolves network names into network addresses.

**Values** ipv4-address - a.b.c.d

ipv6-address - x:x:x:x:x:x:x (eight 16-bit pieces)  
x:x:x:x:x:d.d.d.d

x - [0..FFFF]H  
d - [0..255]D

**source** *ip-address* — Specifies the IP address to be used as the source for performing an OAM ping operation.

**Values**    ipv4-address - a.b.c.d  
              ipv6-address - x:x:x:x:x:x:x:x (eight 16-bit pieces)  
                              x:x:x:x:x:x:d.d.d.d  
                              x - [0..FFFF]H  
                              d - [0..255]D

**send-count** *send-count* — The number of messages to send, expressed as a decimal integer. The **send-count** parameter is used to override the default number of message requests sent. Each message request must either timeout or receive a reply before the next message request is sent. The message **interval** value must be expired before the next message request is sent.

**Default**    1

**Values**    1 — 255

**timeout** *timeout* — The **timeout** parameter in seconds, expressed as a decimal integer. This value is used to override the default **timeout** value and is the amount of time that the router will wait for a message reply after sending the message request. Upon the expiration of message timeout, the requesting router assumes that the message response will not be received. Any response received after the request times out will be silently discarded.

**Default**    5

**Values**    1 — 120

**interval** *interval* — The **interval** parameter in seconds, expressed as a decimal integer. This parameter is used to override the default request message send interval and defines the minimum amount of time that must expire before the next message request is sent.

If the **interval** is set to 1 second, and the **timeout** value is set to 10 seconds, then the maximum time between message requests is 10 seconds and the minimum is 1 second. This depends upon the receipt of a message reply corresponding to the outstanding message request.

**Default**    1

**Values**    1 — 10

**record-type** — Specifies a record type.

**Values**    **ipv4-a-record** - A record specific mapping a host name to an IPv4 address.  
              **ipv6-aaaa-record** - A record specific to the Internet class that stores a single IPv6 address.

## eth-cfm-linktrace

**Syntax**    **eth-cfm-linktrace** *mac-address mep mep-id domain md-index association ma-index [ttl ttlvalue]*

## OAM testhead commands

[**fc** {*fc-name*} ] [**send-count** *send-count*] [**timeout** *timeout*] [**interval** *interval*] [**record-type** {ipv4-a-record|ipv6-aaaa-record}]

**Context** config>saa>test>type

**Description** This command configures a CFM linktrace test in SAA.

**Parameters-** *mac-address* — Specifies a unicast destination MAC address.

**mep** *mep-id* — Specifies the target MAC address.

**Values** 1 — 8191

**domain** *md-index* — Specifies the MD index.

**Values** 1 — 4294967295

**association** *ma-index* — Specifies the MA index.

**Values** 1 — 4294967295

**tll** *tll-value* — Specifies the maximum number of hops traversed in the linktrace.

**Default** 64

**Values** 1— 255

**fc** *fc-name* — The **fc** parameter is used to indicate the forwarding class of the CFM Linktrace request messages.

The actual forwarding class encoding is controlled by the network egress mappings.

**Default** nc

**Values** be, l2, af, l1, h2, ef, h1, nc

**send-count** *send-count* — The number of messages to send, expressed as a decimal integer. The **count** parameter

is used to override the default number of message requests sent. Each message request must either timeout or receive a reply before the next message request is sent. The message **interval** value must be expired before the next message request is sent.

**Default** 1

**Values** 1 — 10

**timeout** *timeout* — The **timeout** parameter in seconds, expressed as a decimal integer. This value is used to override the default **timeout** value and is the amount of time that the router will wait for a message reply after sending the message request. Upon the expiration of message timeout, the requesting router assumes that the message response will not be received. Any response received after the request times out will be silently discarded. The **timeout** value must be less than the **interval**.

**Default** 5

**Values** 1 — 10

**interval** *interval* — The **interval** parameter in seconds, expressed as a decimal integer. This parameter is used to override the default request message send interval and defines the minimum amount of time that must expire before the next message request is sent.

If the **interval** is set to “1” second, and the **timeout** value is set to “10” seconds, then the maximum time

between message requests is “10” seconds and the minimum is “1” second. This depends upon the receipt of a message reply corresponding to the outstanding message request. The **timeout** value must be less than the **interval**.

**Default** 5

**Values** 1 — 10

**record-type** — Specifies a record type.

**Values** ipv4-a-record — A record specific mapping a host name to an IPv4 address.  
 ipv6-aaaa-record — A record specific to the Internet class that stores a single IPv6 address.

## eth-cfm-loopback

**Syntax** **eth-cfm-loopback** *mac-address* **mep** *mep-id* **domain** *md-index* **association** *ma-index* [**size** *datasize*] [**fc** {*fc-name*} ] [**count** *send-count*] [**timeout** *timeout*] [**interval** *interval*]

**Context** config>saa>test>type

**Description** This command configures an Ethernet CFM loopback test in SAA.

*mac-address* — Specifies a unicast destination MAC address.

**mep** *mep-id* — Specifies the target MAC address.

**Values** 1 — 8191

**domain** *md-index* — Specifies the MD index.

**Values** 1 — 4294967295

**association** *ma-index* — Specifies the MA index.

**Values** 1 — 4294967295

**size** *data-size* — The packet size in bytes, expressed as a decimal integer.

**Default** 0

**Values** 0 — 1500

**fc** *fc-name* — The **fc** parameter is used to indicate the forwarding class of the CFM Loopback request messages.

The actual forwarding class encoding is controlled by the network egress mappings.

**Default** nc

**Values** be, l2, af, l1, h2, ef, h1, nc

**count** *send-count* — The number of messages to send, expressed as a decimal integer. The **count** parameter is used to override the default number of message requests sent. Each message request must either timeout or receive a reply before the next message request is sent. The message **interval** value must be expired before the next message request is sent.

## OAM testhead commands

**Default** 1

**Values** 1 — 100

**timeout** *timeout* — The **timeout** parameter in seconds, expressed as a decimal integer. This value is used to override the default **timeout** value and is the amount of time that the router will wait for a message reply after sending the message request. Upon the expiration of message timeout, the requesting router assumes that the message response will not be received. Any response received after the request times out will be silently discarded. The **timeout** value must be less than the **interval**.

**Default** 5

**Values** 1 — 10

**interval** *interval* — The **interval** parameter in seconds, expressed as a decimal integer. This parameter is used to override the default request message send interval and defines the minimum amount of time that must expire before the next message request is sent.

If the **interval** is set to “1” second, and the **timeout** value is set to “10” seconds, then the maximum time between message requests is “10” seconds and the minimum is “1” second. This depends upon the receipt of a message reply corresponding to the outstanding message request. The **timeout** value must be less than the **interval**.

**Default** 5

**Values** 1 — 10

## eth-cfm-two-way-delay

**Syntax** **eth-cfm-two-way-delay** *mac-address* **mep** *mep-id* **domain** *md-index* **association** *ma-index* [**fc** *{fc-name}*] [**send-count** *send-count*] [**timeout** *timeout*] [**interval** *interval*]

**Context** config>saa>test>type

**Description-** This command configures an Ethernet CFM two-way delay test in SAA.

*mac-address* — Specifies a unicast destination MAC address.

**mep** *mep-id* — Specifies the target MAC address.

**Values** 1 — 8191

**domain** *md-index* — Specifies the MD index.

**Values** 1 — 4294967295

**association** *ma-index* — Specifies the MA index.

**Values** 1 — 4294967295

*ttl* *ttl-value* — Specifies the maximum number of hops traversed in the linktrace.

**Default** 64

**Values** 1 — 255

**fc** *fc-name* — The **fc** parameter is used to indicate the forwarding class of the CFM two-delay request

messages.

The actual forwarding class encoding is controlled by the network egress mappings.

**Default** nc

**Values** be, l2, af, l1, h2, ef, h1, nc

**send-count** *send-count* — The number of messages to send, expressed as a decimal integer. The **count** parameter

is used to override the default number of message requests sent. Each message request must either timeout or receive a reply before the next message request is sent. The message **interval** value must be expired before the next message request is sent.

**Default** 1

**Values** 1 — 100

**timeout** *timeout* — The **timeout** parameter in seconds, expressed as a decimal integer. This value is used to override the default **timeout** value and is the amount of time that the router will wait for a message reply after sending the message request. Upon the expiration of message timeout, the requesting router assumes that the message response will not be received. Any response received after the request times out will be silently discarded. The **timeout** value must be less than the **interval**.

**Default** 5

**Values** 1 — 10

**interval** *interval* — The **interval** parameter in seconds, expressed as a decimal integer. This parameter is used to override the default request message send interval and defines the minimum amount of time that must expire before the next message request is sent.

If the **interval** is set to “1” second, and the **timeout** value is set to “10” seconds, then the maximum time between message requests is “10” seconds and the minimum is “1” second. This depends upon the receipt of a message reply corresponding to the outstanding message request. The **timeout** value must be less than the **interval**.

**Default** 5

**Values** [0.1, 0.2, .. 0.9] | [1, 2, .. 10]

## eth-cfm-two-way-slm

**Syntax** **eth-cfm-two-way-delay** *mac-address* **mep** *mep-id* **domain** *md-index* **association** *ma-index* [**fc** *{fc-name}*] [**send-count** *send-count*] [**size** *data-size*] [**timeout** *timeout*] [**interval** *interval*]

**Context** config>saa>test>type

**Description** This command configures an Ethernet CFM two-way SLM test in SAA.

*mac-address* — Specifies a unicast destination MAC address.

**mep** *mep-id* — Specifies the target MAC address.

**Values** 1 — 8191

## OAM testhead commands

**domain** *md-index* — Specifies the MD index.

**Values** 1 — 4294967295

**association** *ma-index* — Specifies the MA index.

**Values** 1 — 4294967295

**fc** *fc-name* — The fc parameter is used to indicate the forwarding class of the CFM SLM request messages. The actual forwarding class encoding is controlled by the network egress mappings.

**Default** nc

**Values** be, l2, af, l1, h2, ef, h1, nc

**send-count** *send-count* — The number of messages to send, expressed as a decimal integer. The count parameter is used to override the default number of message requests sent. Each message request must either timeout or receive a reply before the next message request is sent. The message interval value must be expired before the next message request is sent.

**Default** 1

**Values** 1 — 100

**size** *data-size* — This is the size of the data portion of the data TLV. If 0 is specified no data TLV is added to the packet.

**Default** 0

**Values** 0 — 1500

**timeout** *timeout* — The timeout parameter in seconds, expressed as a decimal integer. This value is used to override the default timeout value and is the amount of time that the router waits for a message reply after sending the message request. Upon the expiration of message timeout, the requesting router assumes that the message response is not received. Any response received after the request times out is silently discarded. The timeout value must be less than the interval.

**Default** 5

**Values** 1 — 10

**interval** *interval* — The interval parameter in seconds, expressed as a decimal integer. This parameter is used to override the default request message send interval and defines the minimum amount of time that must expire before the next message request is sent. If the interval is set to 1 second, and the timeout value is set to 10 seconds, then the maximum time between message requests is 10 seconds and the minimum is 1 second. This depends upon the receipt of a message reply corresponding to the outstanding message request. The timeout value must be less than the interval.

**Default** 5

**Values** [0.1, 0.2, .. 0.9] | [1, 2, .. 10]

## icmp-ping

**Syntax** **icmp-ping** [*ip-address* | *dns-name*] [**rapid** | **detail**] [**ttl** *time-to-live*] [**tos** *type-of-service*] [**size** *bytes*] [**pattern** *pattern*] [**source** *ip-address* | *dns-name*] [**interval** *seconds*] [{**next-hop** *ip-address*}

| **{interface interface-name}** | **bypass-routing**] [**count requests**] [**do-not-fragment**] [**router router-instance** | **service-name service-name**] [**timeout timeout**]

**Context** config>saa>test>type

**Description** This command configures an ICMP ping test.

**Parameters** *ip-address* — The far-end IP address to which to send the **svc-ping** request message in dotted decimal notation.

**Values**

ipv4-address:	a.b.c.d
ipv6-address:	x:x:x:x:x:x:x (eight 16-bit pieces)
	x:x:x:x:x:d.d.d.d
x:	[0 .. FFFF]H
d:	[0 .. 255]D

*dns-name* — The DNS name of the far-end device to which to send the **svc-ping** request message, expressed as a character string up to 63 characters maximum.

**rapid** — Packets will be generated as fast as possible instead of the default 1 per second.

**detail** — Displays detailed information.

**ttl time-to-live** — The TTL value for the IP packet, expressed as a decimal integer.

**Values** 1 — 128

**tos type-of-service** — Specifies the service type.

**Values** 0 — 255

**size bytes** — The request packet size in bytes, expressed as a decimal integer.

**Values** 0 — 16384

**pattern pattern** — The data portion in a ping packet will be filled with the pattern value specified. If not specified, position info will be filled instead.

**Values** 0 — 65535

**source ip-address/dns-name** — Specifies the IP address to be used.

**Values** ipv4-address: a.b.c.d dns-name: 128 characters max

**interval seconds** — This parameter is used to override the default request message send interval and defines the minimum amount of time that must expire before the next message request is sent.

If the **interval** is set to 1 second, and the **timeout** value is set to 10 seconds, then the maximum time between message requests is 10 seconds and the minimum is 1 second. This depends upon the receipt of a message reply corresponding to the outstanding message request.

**Default** 1

**Values** 1 — 10

**next-hop ip-address** — Only displays static routes with the specified next hop IP address.

**Values** ipv4-address: a.b.c.d (host bits must be 0)

**interface interface-name** — The name used to refer to the interface. The name must already exist in the **config>router>interface** context.

## OAM testhead commands

**bypass-routing** — Specifies whether to send the ping request to a host on a directly attached network bypassing the routing table.

**count requests** — Specifies the number of times to perform an OAM ping probe operation. Each OAM echo message request must either timeout or receive a reply before the next message request is sent.

**Values** 1 — 100000

**Default** 5

**do-not-fragment** — Sets the DF (Do Not Fragment) bit in the ICMP ping packet.

**router router-instance** — Specifies the router name or service ID.

**Values** *router-name:* Base , management  
*service-id:* 1 — 2147483647

**Default** Base

**service-name service-name** — Specifies the service name as an integer.

**Values** *service-id:* 1 — 2147483647

**timeout timeout** — Overrides the default **timeout** value and is the amount of time that the router will wait for a message reply after sending the message request. Upon the expiration of message timeout, the requesting router assumes that the message response will not be received. Any response received after the request times out will be silently discarded.

**Default** 5

**Values** 1 — 10

## icmp-trace

**Syntax** **icmp-trace** [*ip-address* | *dns-name*] [**ttl** *time-to-live*] [**wait** *milli-seconds*] [**tos** *type-of-service*] [**source** *ip-address*] [**tos** *type-of-service*] [**router** *router-instance* | **service-name** *service-name*]

**Context** config>saa>test>type

**Description** This command configures an ICMP traceroute test.

**Parameters** *ip-address* — The far-end IP address to which to send the **svc-ping** request message in dotted decimal notation.

**Values** *ipv4-address:* a.b.c.d  
*ipv6-address:* x:x:x:x:x:x:x (eight 16-bit pieces)  
x:x:x:x:x:d.d.d.d  
x: [0 .. FFFF]H  
d: [0 .. 255]D

*dns-name* — The DNS name of the far-end device to which to send the **svc-ping** request message, expressed as a character string to 63 characters maximum.

**ttl time-to-live** — The TTL value for the MPLS label, expressed as a decimal integer.

**Values** 1 — 255

**wait** *milliseconds* — The time in milliseconds to wait for a response to a probe, expressed as a decimal integer.

**Default** 5000

**Values** 10 — 60000

**tos** *type-of-service* — Specifies the service type.

**Values** 0 — 255

**source** *ip-address* — Specifies the IP address to be used.

**Values**

ipv4-address:	a.b.c.d
ipv6-address:	x:x:x:x:x:x:x (eight 16-bit pieces)
	x:x:x:x:x:d.d.d.d
x:	[0 .. FFFF]H
d:	[0 .. 255]D

**router** *router-instance* — Specifies the router name or service ID.

**Values**

<i>router-name:</i>	Base, management
<i>service-id:</i>	1 — 2147483647

**Default** Base

## Isp-ping

Note: This command is not supported on 7210 SAS-M and 7210 SAS-T devices configured in Access uplink mode.

**Syntax** **isp-ping** *{lsp-name [path path-name]}* [**fc** *fc-name*] [**src-ipaddress** *ip-address*] [**size** *octets*][**t***ttl label-ttl*] [**send-count** *send-count*] [**timeout** *timeout*] [**interval** *interval*]

**Context** oam  
config>saa>test>type

**Description** This command performs in-band LSP connectivity tests.

The **isp-ping** command performs an LSP ping using the protocol and data structures defined in the RFC 4379, Detecting Multi-Protocol Label Switched (MPLS) Data Plane Failures.

The LSP ping operation is modeled after the IP ping utility which uses ICMP echo request and reply packets to determine IP connectivity.

In an LSP ping, the originating device creates an MPLS echo request packet for the LSP and path to be tested. The MPLS echo request packet is sent through the data plane and awaits an MPLS echo reply packet from the device terminating the LSP. The status of the LSP is displayed when the MPLS echo reply packet is received.

**Parameters** *lsp-name* — Name that identifies an LSP to ping. The LSP name can be up to 32 characters long.

**path** *path-name* — The LSP path name along which to send the LSP ping request.

**Default** The active LSP path.

**Values** Any path name associated with the LSP.

## OAM testhead commands

**fc** *fc-name* — The **fc** parameter is used to indicate the forwarding class of the MPLS echo request packets. The actual forwarding class encoding is controlled by the network egress LSP-EXP mappings.

The LSP-EXP mappings on the receive network interface controls the mapping back to the internal forwarding class used by the far-end 7210 SAS M that receives the message request. The egress mappings of the egress network interface on the far-end 7210 SAS M controls the forwarding class markings on the return reply message.

The LSP-EXP mappings on the receive network interface controls the mapping of the message reply back at the originating router.

**Default**     be

**Values**     be, l2, af, l1, h2, ef, h1, nc

**size** *octets* — The MPLS echo request packet size in octets, expressed as a decimal integer. The request payload is padded with zeroes to the specified size.

**Default**     68 — The system sends the minimum packet size, depending on the type of LSP. No padding is added.

**Values**     84 — 65535

**ttl** *label-ttl* — The TTL value for the MPLS label, expressed as a decimal integer.

**Default**     255

**Values**     1 — 255

**send-count** *send-count* — The number of messages to send, expressed as a decimal integer. The **send-count** parameter is used to override the default number of message requests sent. Each message request must either timeout or receive a reply before the next message request is sent. The message **interval** value must be expired before the next message request is sent.

**Default**     1

**Values**     1 — 100

**src-ip-address** *ip-addr* — Specifies the source IP address. This option is used when an OAM packet must be generated from a different address than the node's system interface address. An example is when the OAM packet is sent over an LDP LSP and the LDP LSR-ID of the corresponding LDP session to the next-hop is set to an address other than the system interface address.

**Values**     ipv4-address: a.b.c.d

**timeout** *timeout* — The **timeout** parameter in seconds, expressed as a decimal integer. This value is used to override the default **timeout** value and is the amount of time that the router will wait for a message reply after sending the message request. Upon the expiration of message timeout, the requesting router assumes that the message response will not be received. Any response received after the request times out will be silently discarded.

**Default**     5

**Values**     1 — 10

**interval** *interval* — The **interval** parameter in seconds, expressed as a decimal integer. This parameter is used to override the default request message send interval and defines the minimum amount of time that must expire before the next message request is sent.

If the **interval** is set to 1 second, and the **timeout** value is set to 10 seconds, then the maximum time between message requests is 10 seconds and the minimum is 1 second. This depends upon the receipt of a message reply corresponding to the outstanding message request.

**Default** 1

**Values** 1 — 10

## lsp-trace

Note: This command is not supported on 7210 SAS-M and 7210 SAS-T devices configured in Access uplink mode.

**Syntax** **lsp-trace** *{lsp-name [path path-name]}* [**src-ipaddress** ip-address] [**fc** fc-name] [**max-fail** no-response-count] [**probe-count** probes-per-hop] [**size** octets] [**min-ttl** min-label-ttl] [**max-ttl** max-label-ttl] [**timeout** timeout] [**interval** interval]

**Context** oam  
config>saa>test>type

**Description** This command displays the hop-by-hop path for an LSP.

The **lsp-trace** command performs an LSP traceroute using the protocol and data structures defined in the IETF draft (draft-ietf-mpls-lsp-ping-02.txt).

The LSP traceroute operation is modeled after the IP traceroute utility which uses ICMP echo request and reply packets with increasing TTL values to determine the hop-by-hop route to a destination IP.

In an LSP traceroute, the originating device creates an MPLS echo request packet for the LSP to be tested with increasing values of the TTL in the outermost label. The MPLS echo request packet is sent through the data plane and awaits a TTL exceeded response or the MPLS echo reply packet from the device terminating the LSP. The devices that reply to the MPLS echo request packets with the TTL exceeded and the MPLS echo reply are displayed.

**Parameters** *lsp-name* — Name that identifies an LSP to ping. The LSP name can be up to 32 characters long.

**path** *path-name* — The LSP pathname along which to send the LSP trace request.

**Default** The active LSP path.

**Values** Any path name associated with the LSP.

**min-ttl** *min-label-ttl* — The minimum TTL value in the MPLS label for the LSP trace test, expressed as a decimal integer.

**Default** 1

**Values** 1 — 255

**max-ttl** *max-label-ttl* — The maximum TTL value in the MPLS label for the LDP tree-trace test, expressed as a decimal integer.

**Default** 30

**Values** 1 — 255

**max-fail** *no-response-count* — The maximum number of consecutive MPLS echo requests, expressed as a

## OAM testhead commands

decimal integer that do not receive a reply before the trace operation fails for a given TTL.

**Default** 5

**Values** 1 — 255

**src-ip-address** *ip-addr* — Specifies the source IP address. This option is used when an OAM packet must be generated from a different address than the node's system interface address. An example is when the OAM packet is sent over an LDP LSP and the LDP LSR-ID of the corresponding LDP session to the next-hop is set to an address other than the system interface address.

**Values** ipv4-address: a.b.c.d

**timeout** *timeout* — The **timeout** parameter in seconds, expressed as a decimal integer. This value is used to override the default **timeout** value and is the amount of time that the 7210 SAS M will wait for a message reply after sending the message request. Upon the expiration of message timeout, the requesting router assumes that the message response will not be received. A 'request timeout' message is displayed by the CLI for each message request sent that expires. Any response received after the request times out will be silently discarded.

**Default** 3

**Values** 1 — 10

**interval** *interval* — The **interval** parameter in seconds, expressed as a decimal integer. This parameter is used to override the default request message send interval and defines the minimum amount of time that must expire before the next message request is sent.

If the **interval** is set to 1 second, and the **timeout** value is set to 10 seconds, then the maximum time between message requests is 10 seconds and the minimum is 1 second. This depends upon the receipt of a message reply corresponding to the outstanding message request.

**Default** 1

**Values** 1 — 10

**fc** *fc-name* — The **fc** parameter is used to indicate the forwarding class of the MPLS echo request packets. The actual forwarding class encoding is controlled by the network egress LSP-EXP mappings.

The LSP-EXP mappings on the receive network interface controls the mapping back to the internal forwarding class used by the far-end 7210 SAS M that receives the message request. The egress mappings of the egress network interface on the far-end 7210 SAS M controls the forwarding class markings on the return reply message.

The LSP-EXP mappings on the receive network interface controls the mapping of the message reply back at the originating 7210 SAS M.

**Default** be

**Values** be, l2, af, l1, h2, ef, h1, nc

## mac-ping

Note: This command is not supported on 7210 SAS-M and 7210 SAS-T devices configured in Access uplink mode.

<b>Syntax</b>	<b>mac-ping service</b> <i>service-id</i> <b>destination</b> <i>dst-ieee-address</i> [ <b>source</b> <i>src-ieee-address</i> ] [ <b>fc</b> <i>fc-name</i> ] [ <b>size</b> <i>octets</i> ] [ <b>ttl</b> <i>vc-label-ttl</i> ] [ <b>send-count</b> <i>send-count</i> ] [ <b>send-control</b> ] [ <b>return-control</b> ] [ <b>interval</b> <i>interval</i> ] [ <b>timeout</b> <i>timeout</i> ]
<b>Context</b>	oam config>saa>test>type
<b>Description</b>	<p>The mac-ping utility is used to determine the existence of an egress SAP binding of a given MAC within a VPLS service.</p> <p>A <b>mac-ping</b> packet can be sent via the control plane or the data plane. The <b>send-control</b> option specifies the request be sent using the control plane. If <b>send-control</b> is not specified, the request is sent using the data plane.</p> <p>A <b>mac-ping</b> is forwarded along the flooding domain if no MAC address bindings exist. If MAC address bindings exist, then the packet is forwarded along those paths, provided they are active. A response is generated only when there is an egress SAP binding for that MAC address or if the MAC address is a “local” OAM MAC address associated with the device’s control plane.</p> <p>A <b>mac-ping</b> reply can be sent using the data plane or the control plane. The <b>return-control</b> option specifies the reply be sent using the control plane. If <b>return-control</b> is not specified, the request is sent using the data plane.</p> <p>A <b>mac-ping</b> with data plane reply can only be initiated on nodes that can have an egress MAC address binding. A node without a FIB and without any SAPs cannot have an egress MAC address binding, so it is not a node where replies in the data plane will be trapped and sent up to the control plane.</p> <p>A control plane request is responded to via a control plane reply only.</p> <p>By default, MAC OAM requests are sent with the system or chassis MAC address as the source MAC. The <b>source</b> option allows overriding of the default source MAC for the request with a specific MAC address.</p> <p>When a <b>source</b> <i>ieee-address</i> value is specified and the source MAC address is locally registered within a split horizon group (SHG), then this SHG membership will be used as if the packet originated from this SHG. In all other cases, SHG 0 (zero) will be used. Note that if the <b>mac-trace</b> is originated from a non-zero SHG, such packets will not go out to the same SHG.</p> <p>If EMG is enabled, mac-ping will return only the first SAP in each chain.</p>
<b>Parameters</b>	<p><b>service</b> <i>service-id</i> — The service ID of the service to diagnose or manage.</p> <p style="padding-left: 2em;"><b>Values</b>     <i>service-id</i>:        1 — 2147483647</p> <p><b>destination</b> <i>ieee-address</i> — The destination MAC address for the OAM MAC request.</p> <p><b>size</b> <i>octets</i> — The MAC OAM request packet size in octets, expressed as a decimal integer. The request payload is padded to the specified size with a 6 byte PAD header and a byte payload of 0xAA as necessary. If the octet size specified is less than the minimum packet, the minimum sized packet necessary to send the request is used.</p> <p style="padding-left: 2em;"><b>Default</b>     No OAM packet padding.</p> <p style="padding-left: 2em;"><b>Values</b>     1 — 65535</p> <p><b>ttl</b> <i>vc-label-ttl</i> — The TTL value in the VC label for the OAM MAC request, expressed as a decimal integer.</p> <p style="padding-left: 2em;"><b>Default</b>     255</p> <p style="padding-left: 2em;"><b>Values</b>     1 — 255</p>

## OAM testhead commands

**send-control** — Specifies the MAC OAM request be sent using the control plane instead of the data plane.

**Default** MAC OAM request sent using the data plane.

**return-control** — Specifies the MAC OAM reply to a data plane MAC OAM request be sent using the control plane instead of the data plane.

**Default** MAC OAM reply sent using the data plane.

**source** *src-ieee-address* — The source MAC address from which the OAM MAC request originates. By default, the system MAC address for the chassis is used.

**Default** The system MAC address.

**Values** Any unicast MAC value.

**fc** *fc-name* — The **fc** parameter is used to test the forwarding class of the MPLS echo request packets. The actual forwarding class encoding is controlled by the network egress LSP-EXP mappings.

**Values** be, l2, af, l1, h2, ef, h1, nc

**interval** *interval* — The **interval** parameter in seconds, expressed as a decimal integer. This parameter is used to override the default request message send interval and defines the minimum amount of time that must expire before the next message request is sent.

If the **interval** is set to 1 second where the **timeout** value is set to 10 seconds, then the maximum time between message requests is 10 seconds and the minimum is 1 second. This depends upon the receipt of a message reply corresponding to the outstanding message request.

**Default** 1

**Values** 1 — 10

**send-count** *send-count* — The number of messages to send, expressed as a decimal integer. The **count** parameter is used to override the default number of message requests sent. Each message request must either timeout or receive a reply before the next message request is sent. The message **interval** value must be expired before the next message request is sent.

**Default** 1

**Values** 1 — 100

**timeout** *timeout* — The **timeout** parameter in seconds, expressed as a decimal integer. This value is used to override the default **timeout** value and is the amount of time that the router will wait for a message reply after sending the message request. Upon the expiration of message timeout, the requesting router assumes that the message response will not be received. Any response received after the request times out will be silently discarded.

**Default** 5

**Values** 1 — 10

### Sample Output

```
oam mac-ping service 1 destination 00:bb:bb:bb:bb:bb
Seq Node-id Path RTT
-----
[Send request Seq. 1, Size 126]
1 2.2.2.2:sap1/1/1:1 In-Band 960ms
```

## sdp-ping

Note: This command is not supported on 7210 SAS-M and 7210 SAS-T devices configured in Access uplink mode.

**Syntax** **sdp-ping** *orig-sdp-id* [**resp-sdp** *resp-sdp-id*] [**fc** *fc-name* [**profile** {**in** | **out**}] ] [**timeout** *seconds*] [**interval** *seconds*] [**size** *octets*] [**send-count** *send-count*] [**interval** *<interval>*]

**Context** oam  
config>saa>test>type

**Description** This command tests SDPs for uni-directional or round trip connectivity and performs SDP MTU Path tests. The **sdp-ping** command accepts an originating SDP-ID and an optional responding SDP-ID. The size, number of requests sent, message time-out and message send interval can be specified. All **sdp-ping** requests and replies are sent with PLP OAM-Label encapsulation, as a *service-id* is not specified. For round trip connectivity testing, the **resp-sdp** keyword must be specified. If **resp-sdp** is not specified, a uni-directional SDP test is performed.

To terminate an **sdp-ping** in progress, use the CLI break sequence <Ctrl-C>.

An **sdp-ping** response message indicates the result of the **sdp-ping** message request. When multiple response messages apply to a single SDP echo request/reply sequence, the response message with the high precedence will be displayed. The following table displays the response messages sorted by precedence.

Result of Request	Displayed Response Message	Precedence
Request timeout without reply	Request Timeout	1
Request not sent due to non-existent <i>orig-sdp-id</i>	Orig-SDP Non-Existent	2
Request not sent due to administratively down <i>orig-sdp-id</i>	Orig-SDP Admin-Down	3
Request not sent due to operationally down <i>orig-sdp-id</i>	Orig-SDP Oper-Down	4
Request terminated by user before reply or timeout	Request Terminated	5
Reply received, invalid <i>origination-id</i>	Far End: Originator-ID Invalid	6
Reply received, invalid <i>responder-id</i>	Far End: Responder-ID Error	7
Reply received, non-existent <i>resp-sdp-id</i>	Far End: Resp-SDP Non-Existent	8
Reply received, invalid <i>resp-sdp-id</i>	Far End: Resp-SDP Invalid	9
Reply received, <i>resp-sdp-id</i> down (admin or oper)	Far-end: Resp-SDP Down	10
Reply received, No Error	Success	11

Parameters *orig-sdp-id* — The SDP-ID to be used by **sdp-ping**, expressed as a decimal integer. The far-end address of

## OAM testhead commands

the specified SDP-ID is the expected *responder-id* within each reply received. The specified SDP-ID defines the encapsulation of the SDP tunnel encapsulation used to reach the far end. This can be IP or MPLS. If *orig-sdp-id* is invalid or administratively down or unavailable for some reason, the SDP Echo Request message is not sent and an appropriate error message is displayed (once the **interval** timer expires, sdp-ping will attempt to send the next request if required).

**Values** 1 — 17407

**resp-sdp** *resp-sdp-id* — Optional parameter is used to specify the return SDP-ID to be used by the far-end 7210 SAS M for the message reply for round trip SDP connectivity testing. If *resp-sdp-id* does not exist on the far-end 7210 SAS M, terminates on another 7210 SAS M different than the originating 7210 SAS M, or another issue prevents the far-end router from using *resp-sdp-id*, the SDP echo reply will be sent using generic IP/OAM encapsulation. The received forwarding class (as mapped on the ingress network interface for the far end) defines the forwarding class encapsulation for the reply message.

**Default** null. Use the non-SDP return path for message reply.

**Values** 1 — 17407

**fc** *fc-name* — The **fc** parameter is used to indicate the forwarding class of the SDP encapsulation. The actual forwarding class encoding is controlled by the network egress DSCP or LSP-EXP mappings.

The DSCP or LSP-EXP mappings on the receive network interface controls the mapping back to the internal forwarding class used by the far-end 7210 SAS M that receives the message request. The egress mappings of the egress network interface on the far-end 7210 SAS M controls the forwarding class markings on the return reply message.

The DSCP or LSP-EXP mappings on the receive network interface controls the mapping of the message reply back at the originating 7210 SAS M. This is displayed in the response message output upon receipt of the message reply.

**Default** be

**Values** be, l2, af, l1, h2, ef, h1, nc

**timeout** *seconds* — The **timeout** parameter in seconds, expressed as a decimal integer. This value is used to override the default **timeout** value and is the amount of time that the router will wait for a message reply after sending the message request. Upon the expiration of message timeout, the requesting router assumes that the message response will not be received. A 'request timeout' message is displayed by the CLI for each message request sent that expires. Any response received after the request times out will be silently discarded.

**Default** 5

**Values** 1 — 10

**interval** *seconds* — The **interval** parameter in seconds, expressed as a decimal integer. This parameter is used to override the default request message send interval and defines the minimum amount of time that must expire before the next message request is sent.

If the **interval** is set to 1 second, and the **timeout** value is set to 10 seconds, then the maximum time between message requests is 10 seconds and the minimum is 1 second. This depends upon the receipt of a message reply corresponding to the outstanding message request.

**Default** 1

**Values** 1 — 10

**size octets** — The **size** parameter in octets, expressed as a decimal integer. This parameter is used to override the default message size for the **sdp-ping** request. Changing the message size is a method of checking the ability of an SDP to support a **path-mtu**. The size of the message does not include the SDP encapsulation, VC-Label (if applied) or any DLC headers or trailers.

When the OAM message request is encapsulated in an IP/ SDP, the IP ‘DF’ (Do Not Fragment) bit is set. If any segment of the path between the sender and receiver cannot handle the message size, the message is discarded. MPLS LSPs are not expected to fragment the message either, as the message contained in the LSP is not an IP packet.

**Default** 72

**Values** 72 — 9198

**send-count send-count** — The number of messages to send, expressed as a decimal integer. The **count** parameter is used to override the default number of message requests sent. Each message request must either timeout or receive a reply before the next message request is sent. The message **interval** value must be expired before the next message request is sent.

**Default** 1

**Values** 1 — 100

**Special Cases** Single Response Connectivity Tests — A single response sdp-ping test provides detailed test results.

Upon request timeout, message response, request termination, or request error the following local and remote information will be displayed. Local and remote information will be dependent upon SDP-ID existence and reception of reply.

Field	Description	Values
Request Result	The result of the <b>sdp-ping</b> request message.	Sent - Request Timeout Sent - Request Terminated Sent - Reply Received Not Sent - Non-Existent Local SDP-ID Not Sent - Local SDP-ID Down
Originating SDP-ID	The originating SDP-ID specified by <b>orig-sdp</b> .	<i>orig-sdp-id</i>
Originating SDP-ID Administrative State	The local administrative state of the originating SDP-ID. If the SDP-ID has been shutdown, Admin-Down is displayed. If the originating SDP-ID is in the no shutdown state, Admin-Up is displayed. If the <i>orig-sdp-id</i> does not exist, Non-Existent is displayed.	Admin-Up Admin-Down Non-Existent
Originating SDP-ID Operating State	The local operational state of the originating SDP-ID. If <i>orig-sdp-id</i> does not exist, N/A will be displayed.	Oper-Up Oper-Down N/A

## OAM testhead commands

Field	Description	Values
Originating SDP-ID Path MTU	The local <b>path-mtu</b> for <i>orig-sdp-id</i> . If <i>orig-sdp-id</i> does not exist locally, N/A is displayed.	<i>orig-path-mtu</i> N/A
Responding SDP-ID	The SDP-ID requested as the far-end path to respond to the <b>sdp-ping</b> request. If <b>resp-sdp</b> is not specified, the responding router will not use an SDP-ID as the return path and N/A will be displayed.	<i>resp-sdp-id</i> N/A
Responding SDP-ID Path Used	Displays whether the responding 7210 SAS M used the responding <i>sdp-id</i> to respond to the <b>sdp-ping</b> request. If <i>resp-sdp-id</i> is a valid, operational SDP-ID, it must be used for the SDP echo reply message. If the far-end uses the responding <i>sdp-id</i> as the return path, Yes will be displayed. If the far-end does not use the responding <i>sdp-id</i> as the return path, No will be displayed. If <b>resp-sdp</b> is not specified, N/A will be displayed.	Yes No N/A
Responding SDP-ID Administrative State	The administrative state of the responding <i>sdp-id</i> . When <i>resp-sdp-id</i> is administratively down, Admin-Down will be displayed. When <i>resp-sdp-id</i> is administratively up, Admin-Up will be displayed. When <i>resp-sdp-id</i> exists on the far-end 7210 SAS M but is not valid for the originating router, Invalid is displayed. When <i>resp-sdp-id</i> does not exist on the far-end router, Non-Existent is displayed. When <b>resp-sdp</b> is not specified, N/A is displayed.	Admin-Down Admin-Up Invalid Non-Existent N/A

Field	Description	Values
Responding SDP-ID Operational State	The operational state of the far-end <i>sdp-id</i> associated with the return path for <i>service-id</i> . When a return path is operationally down, Oper-Down is displayed. If the return <i>sdp-id</i> is operationally up, Oper-Up is displayed. If the responding <i>sdp-id</i> is non-existent, N/A is displayed.	Oper-Up Oper-Down N/A
Responding SDP-ID Path MTU	The remote <b>path-mtu</b> for <i>resp-sdp-id</i> . If <i>resp-sdp-id</i> does not exist remotely, N/A is displayed	<i>resp-path-mtu</i> N/A
Local Service IP Address	The local system IP address used to terminate remotely configured <i>sdp-ids</i> (as the <i>sdp-id</i> <b>far-end</b> address). If an IP address has not been configured to be the system IP address, N/A is displayed.	<i>system-ip-addr</i> N/A
Local Service IP Interface Name	The name of the local system IP interface. If the local system IP interface has not been created, N/A is displayed.	<i>system-interface-name</i> N/A
Local Service IP Interface State	The state of the local system IP interface. If the local system IP interface has not been created, Non-Existent is displayed.	Up Down Non-Existent
Expected Far End Address	The expected IP address for the remote system IP interface. This must be the <b>far-end</b> address configured for the <i>orig-sdp-id</i> .	<i>orig-sdp-far-end-addr</i> <i>dest-ip-addr</i> N/A
Actual Far End Address	The returned remote IP address. If a response is not received, the displayed value is N/A. If the far-end service IP interface is down or non-existent, a message reply is not expected.	<i>resp-ip-addr</i> N/A
Responders Expected Far End Address	The expected source of the originators <i>sdp-id</i> from the perspective of the remote terminating the <i>sdp-id</i> . If the far-end cannot detect the expected source of the ingress <i>sdp-id</i> , N/A is displayed.	<i>resp-rec-tunnel-far-end-addr</i> N/A
Round Trip Time	The round trip time between SDP echo request and the SDP echo reply. If the request is not sent, times out or is terminated, N/A is displayed.	<i>delta-request-reply</i> N/A

Multiple Response Connectivity Tests — When the connectivity test count is greater than one (1), a single line is displayed per SDP echo request send attempt.

The request number is a sequential number starting with 1 and ending with the last request sent, incrementing by one (1) for each request. This should not be confused with the *message-id* contained in each request and reply message.

A response message indicates the result of the message request. Following the response message is the round trip time value. If any reply is received, the round trip time is displayed.

## OAM testhead commands

After the last reply has been received or response timed out, a total is displayed for all messages sent and all replies received. A maximum, minimum and average round trip time is also displayed. Error response and timed out requests do not apply towards the average round trip time.

### Multiple Response Round Trip Connectivity Test Sample Output

```
*A:DUT-A# oam sdp-ping 101 resp-sdp 102
Err SDP-ID Info Local Remote
-----
SDP-ID: 101 102
Administrative State: Up Up
Operative State: Up Up
Path MTU: 9186 N/A
Response SDP Used: Yes

IP Interface State: Up
Actual IP Address: 10.20.1.1 10.20.1.2
Expected Peer IP: 10.20.1.2 10.20.1.1

Forwarding Class be be
Profile Out Out

Request Result: Sent - Reply Received
RTT: 10(ms)

*A:DUT-A# oam sdp-ping 101 resp-sdp 102 count 10
Request Response RTT
-----
1 Success 10ms
2 Success 0ms
3 Success 0ms
4 Success 0ms
5 Success 0ms
6 Success 0ms
7 Success 0ms
8 Success 0ms
9 Success 0ms
10 Success 0ms

Sent: 10 Received: 10
Min: 0ms Max: 10ms Avg: 1ms
*A:DUT-A#
```

## vccv-ping

**Note:** This command is not supported on 7210 SAS devices configured in Access uplink mode.

**Syntax** **vccv-ping** *sdp-id:vc-id* [**src-ip-address** *ip-addr* **dst-ip-address** *ip-addr* **pw-id** *pw-id*][**reply-mode** {**ip-routed**|**control-channel**}] [**fc** *fc-name*] [**size** *octets*] [**send-count** *send-count*] [**timeout** *timeout*] [**interval** *interval*] [**ttl** *vc-label-ttl*]

**vccv-ping saii-type2** *global-id:prefix:ac-id* **taii-type2** *global-id:prefix:ac-id* [**reply-mode** *ip-routed|control-channel*] [**src-ip-address** *ip-addr dst-ip-address ip-addr*]  
**vccv-ping spoke-sdp-fec** *spoke-sdp-fec-id* [**reply-mode** *ip-routed*] *control-channel*] [**saii-type2** *global-id:prefix:ac-id* **taii-type2** *global-id:prefix:ac-id*] [**src-ip-address** *ip-addr dst-ip-address ip-addr*]  
**options common to all vccv-ping cases:** [**count** *send-count*] [**fc** *fc-name*] [**profile** *in|out*]  
[**interval** *interval*] [**size** *octets*] [**timeout** *timeout*] [**ttl** *vc-label-ttl*]

Context  
oam  
config>saa>test

Description  
This command configures a Virtual Circuit Connectivity Verification (VCCV) ping test. A vccv-ping test checks connectivity of a VLL inband. It checks to verify that the destination (target) PE is the egress for the Layer 2 FEC. It provides for a cross-check between the dataplane and the control plane. It is inband which means that the vccv-ping message is sent using the same encapsulation and along the same path as user packets in that VLL. The vccv-ping test is the equivalent of the lsp-ping test for a VLL service. The vccv-ping reuses an lsp-ping message format and can be used to test a VLL configured over an MPLS.

Note that VCCV ping can be initiated on TPE or SPE. If initiated on the SPE, the **reply-mode** parameter must be used with the *ip-routed* value. The ping from the TPE can have either values or can be omitted, in which case the default value is used.

If a VCCV ping is initiated from TPE to neighboring a SPE (one segment only) it is sufficient to only use the *sdpid:vcid* parameter. However, if the ping is across two or more segments, at least the *sdpid:vcid*, **src-ip-address** *ip-addr*, **dst-ip-address** *ip-addr*, **ttl** *vc-label-ttl* and **pw-id** *pw-id* parameters are used where:

- The *src-ip-address* is system IP address of the router preceding the destination router.
- The *pwid* is actually the VC ID of the last pseudowire segment.
- The *vc-label-ttl* must have a value equal or higher than the number of pseudowire segments.

Note that VCCV ping is a multi-segment pseudowire. For a single-hop pseudowire, only the peer VCCV CC bit of the control word is advertised when the control word is enabled on the pseudowire. VCCV ping on multi-segment pseudowires require that the control word be enabled in all segments of the VLL.

If the control word is not enabled on spoke SDP it will not be signaled peer VCCV CC bits to the far end, consequently VCCV ping cannot be successfully initiated on that specific spoke SDP.

**Parameters**  
*sdp-id:vc-id* — The VC ID of the pseudowire being tested must be indicated with this parameter. The VC ID needs to exist on the local router and the far-end peer needs to indicate that it supports VCCV to allow the user to send vccv-ping message.

**Values** 1 — 17407:1 — 4294967295

**spoke-sdp-fec** *spoke-sdp-fec-id* — If a FEC 129 PW is being tested, then its *spoke-sdp-fec-id* must be indicated with this parameter. The *spoke-sdp-fec-id* must exist on the local router and the far-end peer needs to indicate that it supports VCCV to allow the user to send vccv-ping messages.

**spoke-sdp-fec** is mutually exclusive with the *sdp-id:vc-id* parameter.

**Values** 1 — 4294967295

**src-ip-address** *ip-addr* — Specifies the source IP address.

**ipv4-address:** a.b.c.d **control-channel** { **ipv4** | **non-ip** } — Specifies the encapsulation format to use for

the VCCV ping echo request and echo reply packet.

**Values** **ipv4** — IPv4 encapsulation in an IPv4 pseudowire associated channel (channel type 0x0021)

**Values** **non-ip** — MPLS-TP encapsulation without UDP/IP headers, in pseudowire associated channel using channel type 0x025.

**Default** non-ip

**saii-type2** *global-id:prefix:ac-id* — If a FEC129 AII Type 2 pseudowire is being tested, then the source attachment individual identifier (SAII) must be indicated.

The **saii-type2** parameter is mutually exclusive with the *sdp-id:vc-id* parameter.

**Syntax:** *global-id* — The global ID of this T-PE node.

Values: 1 — 4294967295

*prefix* — The prefix on this T-PE node that the spoke-SDP is associated with.

*ac-id* — An unsigned integer representing a locally unique identifier for the spoke-SDP.

Values: 1 — 4294967295

**taii-type2** *global-id:prefix:ac-id* — If a FEC129 AII Type 2 pseudowire is being tested, then the target attachment individual identifier (TAII) must be indicated. The **taii-type2** parameter is mutually exclusive with *sdp-id:vc-id*.

**Syntax:** *global-id* — The global ID of the far end T-PE node of the FEC129 pseudowire.

Values: 1 — 4294967295

*prefix* — The prefix on far end T-PE node that the pseudowire being tested is associated with.

Values: ipv4-formatted address: a.b.c.d

*ac-id* — An unsigned integer representing a locally unique identifier for the pseudowire being tested at the far end T-PE.

Values: 1 — 4294967295

**dst-ip-address** *ip-address* — Specifies the destination IP address.

**Values** ipv4-address: a.b.c.d

ipv6-address - x:x:x:x:x:x:x (eight 16-bit pieces)

**pw-id** *pw-id* — Specifies the pseudowire ID to be used for performing a **vccv-ping** operation. The pseudowire ID is a non-zero 32-bit connection ID required by the FEC 128, as defined in RFC 4379, *Detecting Multi-Protocol Label Switched (MPLS) Data Plane Failures*.

**reply-mode** {**ip-routed** | **control-channel**} — The reply-mode parameter indicates to the far-end how to send the reply message. The option **control-channel** indicates a reply mode in-band using vccv control channel.

**Default** control-channel

**fc** *fc-name* — The **fc** parameter is used to indicate the forwarding class of the MPLS echo request packets. The actual forwarding class encoding is controlled by the network egress LSP-EXP mappings.

The LSP-EXP mappings on the receive network interface controls the mapping back to the internal forwarding class used by the far-end 7210 SAS M that receives the message request. The egress mappings of the egress network interface on the far-end router controls the forwarding class markings on the return reply message. The LSP-EXP mappings on the receive network interface controls the mapping of the message reply back at the originating SR.

**Default** be

**Values** be, l2, af, l1, h2, ef, h1, nc

**timeout** *seconds* — The timeout parameter, in seconds, expressed as a decimal integer. This value is used to override the default timeout value and is the amount of time that the router will wait for a message reply after sending the message request. Upon the expiration of message timeout, the requesting router assumes that the message response will not be received. A 'request timeout' message is displayed by the CLI for each message request sent that expires. Any response received after the request times out will be silently discarded.

**Default** 5

**Values** 1 — 10

**interval** *seconds* — The interval parameter in seconds, expressed as a decimal integer. This parameter is used to override the default request message send interval and defines the minimum amount of time that must expire before the next message request is sent.

If the interval is set to 1 second, and the timeout value is set to 10 seconds, then the maximum time between message requests is 10 seconds and the minimum is 1 second. This depends upon the receipt of a message reply corresponding to the outstanding message request.

**Default** 1

**Values** 1 — 10

**size** *octets* — The VCCV ping echo request packet size in octets, expressed as a decimal integer. The request payload is padded with zeroes to the specified size.

**Default** 88

**Values** 88 — 9198

**send-count** *send-count* — The number of messages to send, expressed as a decimal integer. The count parameter is used to override the default number of message requests sent. Each message request must either timeout or receive a reply before the next message request is sent. The message interval value must be expired before the next message request is sent.

**Default** 1

**Values** 1 — 100

**t1l** *vc-label-ttl* — Specifies the time-to-live value for the vc-label of the echo request message. The outer label TTL is still set to the default of 255 regardless of this value.

## vccv-trace

**Syntax** **vccv-trace** *sdp-id:vc-id* [**fc** *fc-name* [**profile** {**in** | **out**}]] [**size** *octets*] [**reply-mode** *ip-routed|control-channel*] [**probe-count** *probe-count*] [**timeout** *timeout*] [**interval** *interval*] [**min-ttl** *min-vc-label-ttl*] [**max-ttl** *max-vc-label-ttl*] [**max-fail** *no-response-count*] [**detail**]

```

vccv-trace saii-type2 global-id:prefix:ac-id taii-type2 global-id:prefix:ac-id [reply-mode ip-routed|control-channel]
vccv-trace spoke-sdp-fec spoke-sdp-fec-id [reply-mode ip-routed] control-channel] [saii-type2 global-id:prefix:ac-id taii-type2 global-id:prefix:ac-id]
options common to all vccv-trace cases: [detail] [fc fc-name] [profile in|out] [interval interval-value] [max-fail no-response-count] [max-ttl max-vc-label-ttl] [min-ttl min-vc-label-ttl] [probe-count probe-count] [size octets] [timeout timeout-value]

```

**Context** oam  
config>saa>test>type

**Description** This command configures a Virtual Circuit Connectivity Verification (VCCV) automated trace test. The automated VCCV-trace can trace the entire path of a PW with a single command issued at the T-PE or at an S-PE. This is equivalent to LSP-Trace and is an iterative process by which the source T-PE or S-PE node sends successive VCCV-Ping messages with incrementing the TTL value, starting from TTL=1.

In each iteration, the T-PE builds the MPLS echo request message in a way similar to vccv-ping. The first message with TTL=1 will have the next-hop S-PE T-LDP session source address in the Remote PE Address field in the PW FEC TLV. Each S-PE which terminates and processes the message will include in the MPLS echo reply message the FEC 128 TLV corresponding the PW segment to its downstream node. The source T-PE or S-PE node can then build the next echo reply message with TTL=2 to test the next-next hop for the MS-PW. It will copy the FEC TLV it received in the echo reply message into the new echo request message. The process is terminated when the reply is from the egress T-PE or when a timeout occurs.

The user can specify to display the result of the VCCV-trace for a fewer number of PW segments of the end-to-end MS-PW path. In this case, the min-ttl and max-ttl parameters are configured accordingly. However, the T-PE/S-PE node will still probe all hops up to min-ttl in order to correctly build the FEC of the desired subset of segments.

**Parameters** *sdpid:vcid* — The VC ID of the pseudowire being tested must be indicated with this parameter. The VC ID needs to exist on the local 7210 SAS M and the far-end peer needs to indicate that it supports VCCV to allow the user to send vccv-ping message.

**Values** 1-17407:1 — 4294967295

**reply-mode** {*ip-routed* / *control-channel*} — The reply-mode parameter indicates to the far-end how to send the reply message. The option control-channel indicates a reply mode in-band using vccv control channel.

Note that when a VCCV trace message is originated from an S-PE node, the user should use the IPv4 reply mode as the replying node does not know how to set the TTL to reach the sending S-PE node. If the user attempts this, a warning is issued to use the ipv4 reply mode.

**Default** control-channel

**control-channel** {*none* | *non-ip*} — The encapsulation format to use for the VCCV ping echo request and echo reply packet.

**Values** none — IPv4 encapsulation in an IPv4 pseudowire associated channel (channel type 0x0021)

**Values** non-ip — MPLS-TP encapsulation without UDP/IP headers, in pseudowire associated channel using channel type 0x025.

**Default** non-ip

**spoke-sdp-fec** *spoke-sdp-fec-id* — If a FEC 129 PW is being tested, then its *spoke-sdp-fec-id* must be indicated with this parameter. The *spoke-sdp-fec-id* must exist on the local router and the far-end peer needs to indicate that it supports VCCV to allow the user to send vccv-ping messages.

**spoke-sdp-fec** is mutually exclusive with the *sdp-id:vc-id* parameter.

**Values** 1 — 4294967295

**saii-type2** *global-id:prefix:ac-id* — If a FEC129 AII Type 2 pseudowire is being tested, then the source attachment individual identifier (SAII) must be indicated.

The **saii-type2** parameter is mutually exclusive with the *sdp-id:vc-id* parameter.

**Syntax:** *global-id* — The global ID of this 7210 T-PE node.

Values: 1 — 4294967295

*prefix* — The prefix on this 7210 T-PE node that the spoke-SDP is associated with.

*ac-id* — An unsigned integer representing a locally unique identifier for the spoke-SDP.

Values: 1 — 4294967295

**taii-type2** *global-id:prefix:ac-id* — If a FEC129 AII Type 2 pseudowire is being tested, then the target attachment individual identifier (TAII) must be indicated. The **taii-type2** parameter is mutually exclusive with *sdp-id:vc-id*.

**Syntax:** *global-id* — The global ID of the far end T-PE of the FEC129 pseudowire.

Values: 1 — 4294967295

*prefix* — The prefix on far end T-PE that the pseudowire being tested is associated with.

Values: ipv4-formatted address: a.b.c.d

*ac-id* — An unsigned integer representing a locally unique identifier for the pseudowire being tested at the far end T-PE.

Values: 1 — 4294967295

**fc** *fc-name* [**profile** {**in** | **out**}] — The *fc* and *profile* parameters are used to indicate the forwarding class of the VCCV trace echo request packets. The actual forwarding class encoding is controlled by the network egress LSP-EXP mappings.

The LSP-EXP mappings on the receive network interface controls the mapping back to the internal forwarding class used by the far-end router that receives the message request. The egress mappings of the egress network interface on the far-end router controls the forwarding class markings on the return reply message. The LSP-EXP mappings on the receive network interface controls the mapping of the message reply back at the originating router.

*fc-name* — The forwarding class of the VCCV trace echo request encapsulation.

**Default** be

**Values** be, l2, af, l1, h2, ef, h1, nc

**profile** {**in** | **out**} — The *profile* state of the VCCV trace echo request encapsulation.

**Default** out

**size** *octets* — The VCCV ping echo request packet size in octets, expressed as a decimal integer. The request payload is padded with zeroes to the specified size.

## OAM testhead commands

**Default** 88

**Values** 88 — 9198

**probe-count** *probe-count* — The number of VCCV trace echo request messages to send per TTL value.

**Default** 1

**Values** 1 — 10

**timeout** *timeout* — The timeout parameter in seconds, expressed as a decimal integer. This value is used to override the default timeout value and is the amount of time that the router will wait for a message reply after sending the message request. Upon the expiration of message timeout, the requesting router assumes that the message response will not be received. A request timeout message is displayed by the CLI for each message request sent that expires. Any response received after the request times out will be silently discarded.

**Default** 3

**Values** 1 — 60

**interval** *interval* — The interval parameter in seconds, expressed as a decimal integer. This parameter is used to override the default request message send interval and defines the minimum amount of time that must expire before the next message request is sent.

If the interval is set to 1 second, and the timeout value is set to 10 seconds, then the maximum time between message requests is 10 seconds and the minimum is 1 second. This depends upon the receipt of a message reply corresponding to the outstanding message request.

**Default** 1

**Values** 1 — 255

**min-ttl** *min-vc-label-ttl* — The TTL value for the VC label of the echo request message for the first hop of the MS-PW for which the results are to be displayed. This is expressed as a decimal integer. Note that the outer label TTL is still set to the default of 255 regardless of the value of the VC label.

**Default** 1

**Values** 1 — 255

**max-ttl** *max-vc-label-ttl* — The TTL value for the VC label of the echo request message for the last hop of the MS-PW for which the results are to be displayed. This is expressed as a decimal integer. Note that the outer label TTL is still set to the default of 255 regardless of the value of the VC label.

**Default** 8

**Values** 1 — 255

**max-fail** *no-response-count* — The maximum number of consecutive VCCV trace echo requests, expressed as a decimal integer that do not receive a reply before the trace operation fails for a given TTL value.

**Default** 5

**Values** 1 — 255

---

## OAM SAA Commands

### saa

**Syntax** `saa test-name [owner test-owner] {start | stop} [no-accounting]`

**Context** oam

**Description** Use this command to start or stop an SAA test.

*test-name* — Name of the SAA test. The test name must already be configured in the **config>saa>test** context.

**owner test-owner** — Specifies the owner of an SAA operation up to 32 characters in length.

**Values** If a *test-owner* value is not specified, tests created by the CLI have a default owner “TiMOS CLI”.

**start** — This keyword starts the test. A test cannot be started if the same test is still running.

A test cannot be started if it is in a shut-down state. An error message and log event will be generated to indicate a failed attempt to start an SAA test run. A test cannot be started if it is in a continuous state.

**stop** — This keyword stops a test in progress. A test cannot be stopped if it is not in progress. A log message will be generated to indicate that an SAA test run has been aborted. A test cannot be stopped if it is in a continuous state.

**no-accounting** — This parameter disables the recording results in the accounting policy. If **no-accounting** is specified, the MIB record produced at the end of the test will not be added to the accounting file. It will however use up one of the three MIB rows available for the accounting module to be collected.

## Twamp commands

### twamp

<b>Syntax</b>	<b>twamp</b>
<b>Context</b>	config>oam-test
<b>Description</b>	This command enables TWAMP functionality.
<b>Default</b>	TWAMP is disabled.

### server

<b>Syntax</b>	<b>retry-count</b> <i>retry-count</i>
<b>Context</b>	config>test-oam>twamp
<b>Description</b>	This command configures the node for TWAMP server functionality.
<b>Default</b>	TWAMP is disabled.

### prefix

<b>Syntax</b>	<b>prefix</b> { <i>ip-prefix</i>   <i>mask</i> } [ <b>create</b> ] <b>no prefix</b>
<b>Context</b>	config>test-oam>twamp>server
<b>Description</b>	This command configures an IP address prefix containing one or more TWAMP clients. In order for a TWAMP client to connect to the TWAMP server (and subsequently conduct tests) it must establish the control connection using an IP address that is part of a configured prefix.
<b>Default</b>	no prefix
<b>Parameters</b>	<b>prefix</b> <i>ip-prefix/mask</i> — Specifies the address prefix and subnet mask of the destination node. <i>ip-prefix</i> — An IPv4 address in dotted decimal notation. <b>Values</b> a.b.c.d <b>Default</b> none <i>mask</i> — The prefix length. <b>Values</b> 0—32 <b>Default</b> none <i>create</i> — keyword - mandatory when creating an entry.

## max-conn-prefix

**Syntax** **max-conn-prefix** *count*  
**no max-conn-prefix**

**Context** config>test-oam>twamp>server>prefix

**Description** This command configures the maximum number of TWAMP control connections by clients with an IP address in a specific prefix. A new control connection is rejected if accepting it would cause either the prefix limit defined by this command or the server limit (max-conn-server) to be exceeded.

The no form of the command sets the default value.

**Default** no max-conn-prefix

**Parameters** *count* — The maximum number of control connections.

**Values** 7210 SAS-M : 16

**Default** 8

**Values** 7210 SAS-T, 7210 SAS-R6, and 7210 SAS-R12: 32

**Default** 16

**Values** 7210 SAS-X : 48

**Default** 24

## max-conn-server

**Syntax** **max-conn-server** *count*  
**no max-conn-server**

**Context** config>test-oam>twamp>server

**Description** This command configures the maximum number of TWAMP control connections from all TWAMP clients. A new control connection is rejected if accepting it would cause either this limit or a prefix limit (max-conn-prefix) to be exceeded.

The no form of the command sets the default value.

**Default** no max-conn-server

**Parameters** *count* — The maximum number of control connections.

**Values** 7210 SAS-M : 16

## OAM testhead commands

<b>Default</b>	8
<b>Values</b>	7210 SAS-T, 7210 SAS-R6, and 7210 SAS-R12: 32
<b>Default</b>	16
<b>Values</b>	7210 SAS-X : 48
<b>Default</b>	24

## inactivity-timeout

**Syntax** **inactivity-timeout** *seconds*  
**no inactivity-timeout**

**Context** config>test-oam>twamp>server

**Description** This command configures the inactivity timeout for all TWAMP-control connections. If no TWAMP control message is exchanged over the TCP connection for this duration of time the connection is closed and all inprogress tests are terminated.

The no form of the command instructs the system to go with the default value.

**Default** no inactivity-timeout

**Parameters** *retry-count* — The duration of the inactivity timeout.

**Values** 60— 3600

**Default** 900

## max-sess-prefix

**Syntax** **max-sess-prefix** *count*  
**no max-sess-prefix**

**Context** config>test-oam>twamp>server>prefix

**Description** This command configures the maximum number of concurrent TWAMP-Test sessions by clients with an IP address in a specific prefix. A new test session (described by a Request-TW-Session message) is rejected if accepting it would cause either the limit defined by this command or the server limit (max-sess-server) to be exceeded.

The no form of the command instructs the system to go with the default value.

**Default** no max-sess-prefix

**Parameters** *count* — The maximum number of concurrent test sessions.

**Values** 7210 SAS-M : 16

<b>Default</b>	8
<b>Values</b>	7210 SAS-T, 7210 SAS-R6, and 7210 SAS-R12: 32
<b>Default</b>	16
<b>Values</b>	7210 SAS-X : 48
<b>Default</b>	24

## max-sess-server

**Syntax** `max-sess-server count`  
`no max-sess-server`

**Context** `config>test-oam>twamp>server`

**Description** This command configures the maximum number of concurrent TWAMP-Test sessions across all allowed clients.

A new test session (described by a Request-TW-Session message) is rejected if accepting it would cause either the limit defined by this command or a prefix limit (max-sess-prefix) to be exceeded.

The no form of the command instructs the system to go with the default value.

**Default** no max-sessions

**Parameters** *count* — The maximum number of concurrent test sessions.

<b>Values</b>	7210 SAS-M : 16
<b>Default</b>	8
<b>Values</b>	7210 SAS-T, 7210 SAS-R6, and 7210 SAS-R12: 32
<b>Default</b>	16
<b>Values</b>	7210 SAS-X : 48
<b>Default</b>	24

---

## Show Commands

### saa

**Syntax** `saa [test-name] [owner test-owner]`

**Context** `show>saa`

**Description** Use this command to display information about the SAA test.

If no specific test is specified a summary of all configured tests is displayed.

If a specific test is specified then detailed test results for that test are displayed for the last three occurrences that this test has been executed, or since the last time the counters have been reset via a system reboot or clear command.

**Parameters** *test-name* — Enter the name of the SAA test for which the information needs to be displayed. The test name must already be configured in the `config>saa>test` context.

This is an optional parameter.

**owner test-owner** — Specifies the owner of an SAA operation up to 32 characters in length.

**Values** 32 characters maximum.

**Default** If a *test-owner* value is not specified, tests created by the CLI have a default owner “TIMOS CLP”.

**Output** **SAA Output** — The following table provides SAA field descriptions.

Label	Description
Test Name	Specifies the name of the test.
Owner Name	Specifies the owner of the test.
Description	Specifies the description for the test type.
Accounting policy	Specifies the associated accounting policy ID.
Administrative status	Specifies whether the administrative status is enabled or disabled.
Test type	Specifies the type of test configured.
Trap generation	Specifies the trap generation for the SAA test.
Test runs since last clear	Specifies the total number of tests performed since the last time the tests were cleared.
Number of failed tests run	Specifies the total number of tests that failed.

Label	Description (Continued)
Last test run	Specifies the last time a test was run.
Threshold type	Indicates the type of threshold event being tested, jitter-event, latency-event, or loss-event, and the direction of the test responses received for a test run: in — inbound out — outbound rt — roundtrip
Direction	Indicates the direction of the event threshold, rising or falling.
Threshold	Displays the configured threshold value.
Value	Displays the measured crossing value that triggered the threshold crossing event.
Last event	Indicates the time that the threshold crossing event occurred.
Run #	Indicates what test run produced the specified values.

test-oam

**Syntax** test-oam

**Context** show

**Description** This command enables the context to display Operations, Administration, and Maintenance test parameters

**Sample Output**

```
*A:Dut-A# show saa "Dut-A:1413:1501" owner "TiMOS"
=====
SAA Test Information
=====
Test name           : Dut-A:1413:1501
Owner name          : TiMOS
Administrative status : Enabled
Test type           : vccv-ping 1413:1501 fc "nc" timeout 10 size 200
                    : count 2
Test runs since last clear : 1
Number of failed test runs : 0
Last test result    : Success
-----
Threshold
Type      Direction Threshold Value      Last Event      Run #
-----
Jitter-in Rising      None      None      Never           None
          Falling    None      None      Never           None
Jitter-out Rising      None      None      Never           None
          Falling    None      None      Never           None
Jitter-rt Rising      None      None      Never           None
```

## OAM testhead commands

	Falling	None	None	Never	None
Latency-in	Rising	None	None	Never	None
	Falling	None	None	Never	None
Latency-out	Rising	None	None	Never	None
	Falling	None	None	Never	None
Latency-rt	Rising	100	None	Never	None
	Falling	None	None	Never	None
Loss-in	Rising	None	None	Never	None
	Falling	None	None	Never	None
Loss-out	Rising	None	None	Never	None
	Falling	None	None	Never	None
Loss-rt	Rising	2	None	Never	None
	Falling	None	None	Never	None

```

=====
Test Run: 144
Total number of attempts: 2
Number of requests that failed to be sent out: 0
Number of responses that were received: 2
Number of requests that did not receive any response: 0
Total number of failures: 0, Percentage: 0
(in ms)           Min           Max           Average       Jitter
Outbound  :           0           0             0             0
Inbound   :          10          20            15            0
Roundtrip :          10          20            15            0
Per test packet:
  Sequence  Outbound  Inbound  RoundTrip  Result
           1           0         20         20  EgressRtr(10.20.1.4)
           2           0         10         10  EgressRtr(10.20.1.4)
=====
*A:Dut-A#

```

## eth-cfm

**Syntax** eth-cfm

**Context** show

**Description** This command enables the context to display CFM information.

## association

**Syntax** association [*ma-index*] [**detail**]

**Context** show>eth-cfm

**Description** This command displays eth-cfm association information.

**Parameters** *ma-index* — Specifies the MA index.

**Values** 1— 4294967295

**detail** — Displays detailed information for the eth-cfm association.

**Sample Output**

```
A:dut-b# show eth-cfm association

=====
CFM Association Table
=====
Md-index   Ma-index   Name                               CCM-interval  Bridge-id
-----
1           1           a1                                  1              1
1           2           a2                                  1              2
2           1           a1                                  1              2
2           2           a2                                  1              1
=====
A:dut-b#
```

**cfm-stack-table**

**Syntax** **cfm-stack-table***up* | *down*[*port* [*port-id* [*vlan* *vlan-id*]]|*sdp* *sdp-id*[:*vc-id*]] [*level* *0..7*]  
[*direction* *up* | *down*]

**Context** show>eth-cfm

**Description** This command displays stack-table information. This stack-table is used to display the various management points MEPs and MIPs that are configured on the system. These can be Service based or facility based. The various option allow the operator to be specific. If no parameters are include then the entire stack-table will be displayed.

**Parameters** **port** *port-id* — Displays the bridge port or aggregated port on which MEPs or MHFs are configured.

**vlan** *vlan-id* — Displays the associated VLAN ID.

**Values** 0 — 4094

**level** — Display the MD level of the maintenance point.

**Values** 0 — 7

**direction** *up* | *down* — Displays the direction in which the MP faces on the bridge port.

**Sample Output**

```
A:dut-b# show eth-cfm cfm-stack-table

=====
CFM SAP Stack Table
=====
Sap          Level Dir  Md-index  Ma-index  Mep-id  Mac-address
-----
1/1/9:1      6     Down  1          1          1        00:25:ba:01:c3:6a
1/1/9:1      7     Down  2          2          1        00:25:ba:01:c3:6a
```

## OAM testhead commands

```
1/1/9:2      6      Down 1      2      1      00:25:ba:01:c3:6a
1/1/9:2      7      Down 2      1      1      00:25:ba:01:c3:6a
=====

=====
CFM Ethernet Tunnel Stack Table
=====
Eth-tunnel   Level Dir  Md-index  Ma-index  Mep-id  Mac-address
-----
=====

=====
CFM SDP Stack Table
=====
Sdp          Level Dir  Md-index  Ma-index  Mep-id  Mac-address
-----
No Matching Entries
=====

=====
CFM Virtual Stack Table
=====
Service      Level Dir  Md-index  Ma-index  Mep-id  Mac-address
-----
No Matching Entries
=====
A:dut-b#
```

## domain

**Syntax** **domain** [*md-index*] [**association** *ma-index* | **all-associations**] [**detail**]

**Context** show>eth-cfm

**Description** This command displays domain information.

**Parameters** *md-index* — Displays the index of the MD to which the MP is associated, or 0, if none.

**Values** [1..4294967295]

**association** *ma-index* — Displays the index to which the MP is associated, or 0, if none.

**all-associations** — Displays all associations to the MD.

**detail** — Displays detailed domain information.

**Sample Output**

```
A:dut-b# show eth-cfm domain

=====
CFM Domain Table
=====
Md-index   Level Name                                     Format
-----
1           6       d1                                           charString
2           7       d2                                           charString
=====
A:dut-b#
```

**mep**

**Syntax** **mep** *mep-id* **domain** *md-index* **association** *ma-index* [**loopback**] [**linktrace**]  
**mep** *mep-id* **domain** *md-index* **association** *ma-index* [**remote-mepid** *mep-id* | **all-remote-mepids**]  
**mep** *mep-id* **domain** *md-index* **association** *ma-index* **eth-test-results** [**remote-peer** *mac-address*]  
**mep** *mep-id* **domain** *md-index* **association** *ma-index* **one-way-delay-test** [**remote-peer** *mac-address*]  
**mep** *mep-id* **domain** *md-index* **association** *ma-index* **two-way-delay-test** [**remote-peer** *mac-address*]  
**mep** *mep-id* **domain** *md-index* **association** *ma-index* **two-way-slm-test** [**remote-peer** *mac-address*]

**Context** show>eth-cfm

**Description** This command displays Maintenance Endpoint (MEP) information.

**Parameters** **domain** *md-index* — Displays the index of the MD to which the MP is associated, or 0, if none.  
**association** *ma-index* — Displays the index to which the MP is associated, or 0, if none.  
**loopback** — Displays loopback information for the specified MEP.  
**linktrace** — Displays linktrace information for the specified MEP.  
**two-way-slm-test** — Includes specified MEP information for two-way-slm-test. **Sample Output**

```
A:dut-b# show eth-cfm mep 1 domain 1 association 1 linktrace

-----
Mep Information
-----
Md-index       : 1                Direction       : Down
Ma-index       : 1                Admin           : Enabled
MepId          : 1                CCM-Enable     : Enabled
IfIndex        : 35946496         PrimaryVid     : 1
FngState       : fngReset         ControlMep     : False
LowestDefectPri : macRemErrXcon    HighestDefect   : none
Defect Flags   : None
Mac Address    : 00:25:ba:01:c3:6a  CcmLtmPriority  : 7
CcmTx         : 0                CcmSequenceErr : 0
```

## OAM testhead commands

```
Eth-1Dm Threshold : 3(sec)
Eth-Ais:           : Disabled
Eth-Tst:           : Disabled
CcmLastFailure Frame:
    None
XconCcmFailure Frame:
    None
```

---

### Mep Linktrace Message Information

---

```
LtRxUnexplained      : 0                      LtNextSequence      : 2
LtStatus              : False                  LtResult             : False
TargIsMepId          : False                  TargMepId           : 0
TargMac               : 00:00:00:00:00:00      TTL                  : 64
EgressId              : 00:00:00:25:ba:01:c3:6a SequenceNum          : 1
LtFlags               : useFDBOnly
```

---

### Mep Linktrace Replies

---

```
SequenceNum          : 1                      ReceiveOrder         : 1
Ttl                  : 63                      Forwarded            : False
LastEgressId         : 00:00:00:25:ba:01:c3:6a TerminalMep         : True
NextEgressId         : 00:00:00:25:ba:00:5e:bf Relay              : rlyHit
ChassisIdSubType     : unknown value (0)
ChassisId:
    None
```

```
ManAddressDomain:
    None
```

```
ManAddress:
    None
```

```
IngressMac           : 00:25:ba:00:5e:bf      Ingress Action      : ingOk
IngrPortIdSubType    : unknown value (0)
```

```
IngressPortId:
    None
```

```
EgressMac            : 00:00:00:00:00:00      Egress Action       : egrNoTlv
EgrPortIdSubType     : unknown value (0)
```

```
EgressPortId:
    None
```

```
Org Specific TLV:
    None
```

```
A:dut-b#
A:dut-b#
```

```
A:dut-b# show eth-cfm mep 1 domain 1 association 1 loopback
```

---

### Mep Information

---

```
Md-index             : 1                      Direction           : Down
Ma-index             : 1                      Admin                : Enabled
MepId                : 1                      CCM-Enable          : Enabled
IfIndex              : 35946496               PrimaryVid           : 1
FngState              : fngReset               ControlMep           : False
LowestDefectPri      : macRemErrXcon           HighestDefect        : none
Defect Flags         : None
Mac Address           : 00:25:ba:01:c3:6a      CcmLtmPriority       : 7
CcmTx                 : 0                      CcmSequenceErr      : 0
Eth-1Dm Threshold    : 3(sec)
Eth-Ais:              : Disabled
Eth-Tst:              : Disabled
```

```
CcmLastFailure Frame:
    None
XconCcmFailure Frame:
    None
```

-----  
Mep Loopback Information  
-----

```
LbRxReply          : 1                LbRxBadOrder       : 0
LbRxBadMsdu        : 0                LbTxReply          : 0
LbSequence         : 2                LbNextSequence     : 2
LbStatus           : False            LbResultOk         : True
DestIsMepId        : False            DestMepId          : 0
DestMac            : 00:00:00:00:00:00 SendCount           : 0
VlanDropEnable     : True              VlanPriority        : 7
Data TLV:
    None
A:dut-b#
```

```
*A:dut-b# show eth-cfm mep 1 domain 4 association 4 two-way-delay-test remote-peer
00:25:ba:00:5e:bf
```

=====  
Eth CFM Two-way Delay Test Result Table  
=====

Peer Mac Addr	Delay (us)	Delay Variation (us)
00:25:ba:00:5e:bf	507	507

```
*A:dut-b#
```

```
*A:dut-b# show eth-cfm mep 1 domain 4 association 4 two-way-delay-test
```

=====  
Eth CFM Two-way Delay Test Result Table  
=====

Peer Mac Addr	Delay (us)	Delay Variation (us)
00:25:ba:00:5e:bf	507	507

```
*A:dut-b#
```

```
*A:dut-a# show eth-cfm mep 2 domain 4 association 4 eth-test-results remote-peer
00:25:ba:01:c3:6a
```

=====  
Eth CFM ETH-Test Result Table  
=====

Peer Mac Addr	FrameCount	Current	Accumulate
	ByteCount	ErrBits	ErrBits
00:25:ba:01:c3:6a	6	0	0
	384	0	0

```
*A:dut-a#
```

```
*A:dut-a# show eth-cfm mep 2 domain 4 association 4 eth-test-results
```

=====  
Eth CFM ETH-Test Result Table  
=====

Current                      Accumulate

## OAM testhead commands

```

Peer Mac Addr          FrameCount  ErrBits    ErrBits
                        ByteCount   CrcErrs    CrcErrs
-----
00:25:ba:01:c3:6a 6           0           0
                        384         0           0
=====
*A:dut-a# show eth-cfm mep 2 domain 4 association 4 one-way-delay-test remote-peer
00:25:ba:01:c3:6a

=====
Eth CFM One-way Delay Test Result Table
=====
Peer Mac Addr          Delay (us)    Delay Variation (us)
-----
00:25:ba:01:c3:6a    402           402
=====
*A:dut-a#

*A:dut-a# show eth-cfm mep 2 domain 4 association 4 one-way-delay-test

=====
Eth CFM One-way Delay Test Result Table
=====
Peer Mac Addr          Delay (us)    Delay Variation (us)
-----
00:25:ba:01:c3:6a    402           402
=====
*A:dut-a#

```

## mip

**Syntax** mip

**Context** show>eth-cfm

**Description** This command displays SAPs/bindings provisioned for allowing the default MIP creation.

```

*A:node-1# show eth-cfm mip
=====
CFM SAP MIP Table
=====
Sap Mip-Enabled Mip Mac Address
-----
1/1/1:1.1 yes Not Configured
=====
CFM SDP MIP Table
=====
Sdp Mip-Enabled Mip Mac Address
-----
No Matching Entries

```

## system-config

**Syntax** system-config**Context** show>eth-cfm**Description** This command shows various system level configuration parameters. These global eth-cfm commands are those which are configured directly under the config>eth-cfm context.

```
# show eth-cfm system-config
=====
CFM System Configuration
=====
Redundancy
MC-LAG Standby MEP Shutdown: true
MC-LAG Hold-Timer : 1 second(s)
Synthetic Loss Measurement
Inactivity Timer : 100 second(s)
=====
```

## twamp server

**Syntax** twamp server**Context** show>test-oam**Description** Used to obtain information about the TWAMP server. It displays summary information for the ip-prefix in use.**Sample Output**

```
*A:Dut-G>show>test-oam# twamp server

=====
TWAMP Server
=====
Admin State           : Down           Operational State    : Down
Up Time               : 0d 00:00:00
Current Connections   : 0               Max Connections     : 8
Connections Rejected : 0               Inactivity Time Out : 900 seconds
Current Sessions      : 0               Max Sessions        : 8
Sessions Rejected     : 0               Sessions Aborted    : 0
Sessions Completed    : 0
Test Packets Rx       : 0               Test Packets Tx     : 0
=====

=====
TWAMP Server Prefix Summary
=====
Prefix                Current    Current  Description
                   Connections Sessions
-----
-----
```

## OAM testhead commands

```
No. of TWAMP Server Prefixes: 0
=====
*A:Dut-G>show>test-oam#
```

### server all

**Syntax** server all

**Context** show>test-oam twamp server

**Description** Used to display detailed information about the TWAMP server and TWAMP clients using different IP prefix.

### Sample Output

```
7210SASM# show test-oam twamp server all

=====
TWAMP Server
=====
Admin State           : Up                Operational State    : Up
Up Time               : 0d 08:17:34
Current Connections   : 0                Max Connections     : 16
Connections Rejected : 0                Inactivity Time Out : 900 seconds
Current Sessions      : 0                Max Sessions        : 16
Sessions Rejected     : 0                Sessions Aborted    : 0
Sessions Completed    : 0
Test Packets Rx       : 0                Test Packets Tx     : 0
=====

TWAMP Server Prefix 30.1.1.0/24
=====
Description           : (Not Specified)
Current Connections   : 0                Max Connections     : 16
Connections Rejected : 0                Max Sessions        : 16
Current Sessions      : 0                Sessions Aborted    : 0
Sessions Rejected     : 0
Sessions Completed    : 0
Test Packets Rx       : 0                Test Packets Tx     : 0
=====

Connection information for TWAMP server prefix 30.1.1.0/24
=====
Client                State      Curr Sessions  Sessions Rejected  Sessions Completed
                   Idle Time (s)  Test Packets Rx  Test Packets Tx
-----
No. of TWAMP Server Connections for Prefix 30.1.1.0/24: 0
=====

TWAMP Server Prefix 60.1.1.0/24
=====
```

```

Description          : (Not Specified)
Current Connections  : 0                Max Connections      : 16
Connections Rejected : 0
Current Sessions     : 0                Max Sessions         : 16
Sessions Rejected    : 0                Sessions Aborted     : 0
Sessions Completed   : 0
Test Packets Rx      : 0                Test Packets Tx      : 0
=====

=====
Connection information for TWAMP server prefix 60.1.1.0/24
=====
Client              State      Curr Sessions  Sessions Rejected  Sessions Completed
                   Idle Time (s)  Test Packets Rx  Test Packets Tx
-----
No. of TWAMP Server Connections for Prefix 60.1.1.0/24: 0
=====
No. of TWAMP Server Prefixes: 2
=====

```

## server prefix

**Syntax** server prefix *ip-prefix/mask*

**Context** show>test-oam twamp server

**Description** Display information about the TWAMP clients using the specified prefix.

### Sample output

```

*A:7210SAS# show test-oam twamp server prefix 60.1.1.0/24

=====
TWAMP Server Prefix 60.1.1.0/24
=====
Description          : (Not Specified)
Current Connections  : 0                Max Connections      : 16
Connections Rejected : 0
Current Sessions     : 0                Max Sessions         : 16
Sessions Rejected    : 0                Sessions Aborted     : 0
Sessions Completed   : 0
Test Packets Rx      : 0                Test Packets Tx      : 0
=====

=====
Connection information for TWAMP server prefix 60.1.1.0/24
=====
Client              State      Curr Sessions  Sessions Rejected  Sessions Completed
                   Idle Time (s)  Test Packets Rx  Test Packets Tx
-----
No. of TWAMP Server Connections for Prefix 60.1.1.0/24: 0

```

## OAM testhead commands

=====

**Parameters** *ip-prefix* — The destination address of the static route.

**Values** [18 chars max]

*mask* — The prefix length.

## testhead-profile

**Syntax** **testhead-profile** *profile-id*

**Context** show>test-oam

**Description** Specifies the testhead profile ID to use with this run/session of testhead invocation. Testhead profile must be configured beforehand using the commands under *config> test-oam> testhead-profile>*.

**Output** **Testhead-profile Output** — The following table provides testhead-profile field descriptions.

Label	Description
Description	Displays the description configured by the user for the test.
Profile Id	Displays the profile identifier.
CIR Configured	Displays the value of the CIR configured.
PIR Configured	Displays the value of the PIR configured.
Frame Size	Displays the size of the frame.
CIR Operational	Displays the value of the CIR operational rate configured.
PIR Operational	Displays the value of the PIR operational rate configured.
CIR Rule	Displays the adaptation rule configured by the user.
InPrf Dot1p	Displays the dot1p value used to identify green or in-profile packets.
Ref. Count	Displays the total number of testhead (completed or running) sessions pointing to a profile or acceptance criteria or a frame payload.
OutPrf Dot1p	Displays the dot1p value used to identify green or out-of-profile packets.
Duration Hrs, mins, and secs	Displays the test duration in hours, minutes, and seconds.
Loss TH	Displays the user configured loss threshold value for comparison with measured value.
Jitter TH	Displays the user configured jitter threshold value for comparison with measured value.

Label	Description (Continued)
InProf Loss TH	Displays the user configured in-profile loss threshold value for comparison with measured value.
OutProf Loss TH	Displays the user configured out-of-profile loss threshold value for comparison with measured value.
Latency TH	Displays the user configured latency threshold value for comparison with measured value.
InProf Latency TH	Displays the user configured in-profile latency threshold value for comparison with measured value.
OutProf Latency TH	Displays the user configured out-of-profile latency threshold value for comparison with measured value.
InProf Jitter TH	Displays the user configured in-profile jitter threshold value for comparison with measured value.
OutProf Jitter TH	Displays the user configured out-of-profile jitter threshold value for comparison with measured value.
CIR TH	Displays the user configured CIR threshold value for comparison with measured value.
PIR TH	Displays the user configured PIR threshold value for comparison with measured value.
Payload Type	Identifies the type of the payload.
Dst Mac	Displays the value of destination MAC configured by the user to use in the frame generated by the testhead tool
Src Mac	Displays the value of source MAC configured by the user to use in the frame generated by the testhead tool
Vlan Tag 1	Displays the values of the outermost vlan-tag configured by the user to use in the frame generated by the testhead tool.
Vlan Tag 2	Displays the values of the second vlan-tag configured by the user to use in the frame generated by the testhead tool.
Ethertype	Displays the values of the ethertype configured by the user to use in the frame generated by the testhead tool.
TOS	Displays the values of the IP TOS (Type of Service) configured by the user to use in the frame generated by the testhead tool.
Src. IP	Displays the values of the source IPv4 address configured by the user to use in the frame generated by the testhead tool.

## OAM testhead commands

Label	Description (Continued)
L4 Dst Port	Displays the values of the TCP header configured by the user to use in the frame generated by the testhead tool.
Protocol	Displays the values of the IP protocol value configured by the user to use in the frame generated by the testhead tool.
Data Pattern	Displays the values of the data pattern configured by the user to use in the frame generated by the testhead tool.
DSCP	Displays the values of the DSCP configured by the user to use in the frame generated by the testhead tool.
TTL	Displays the values of the IP TTL (Time-to-Live) value configured by the user to use in the frame generated by the testhead tool.
Dst. IP	Displays the values of the destination IPv4 address configured by the user to use in the frame generated by the testhead tool.
L4 Src Port	Displays the values of the source port configured by the user to use in the frame generated by the testhead tool.

### Sample Output

```
*A:7210SAS>config>test-oam># show test-oam testhead-profile 1

=====
Y.1564 Testhead Profile
=====
Description      : Testhead_Profile_1
Profile Id       : 1                      Frame Size      : 512
CIR Configured   : 100                   CIR Operational : 96
PIR Configured   : 200                   PIR Operational : 200
CIR Rule         : max                    Ref. Count      : 0
InPrf Dot1p     : 2                      OutPrf Dot1p    : 4
Duration Hrs     : 0
Duration Mins    : 3
Duration Secs    : 0

-----
Acceptance Criteria Id 1
-----
Loss TH          : 0.000100                Jitter TH       : 100
InProf Loss TH   : 0.000100                InProf Jitter TH : 100
OutProf Loss TH  : 0.000100                OutProf Jitter TH : 100

Latency TH       : 100                      Ref. Count      : 0
InProf Latency TH : 100                    CIR TH          : 1000
OutProf Latency TH : 100                    PIR TH         : 200

-----
Frame Payload Id 1
-----
```

```

Payload Type      : tcp-ipv4
Description       : Frame_Payload_1
Dst Mac          : 00:00:00:00:00:02
Src Mac          : 00:00:00:00:00:01
Vlan Tag 1       : Not configured
Vlan Tag 2       : Not configured
Ethertype        : 0x0800
TOS              : 8
Src. IP          : 1.1.1.1
L4 Dst Port      : 50
Protocol         : 6
Data Pattern     : alb2c3d4e5f6
DSCP             : af11
TTL              : 64
Dst. IP          : 2.2.2.2
L4 Src Port      : 40
Ref. Count       : 0
=====
*A:7210SAS>config>test-oam>#

```

## testhead

**Syntax** `testhead test-name owner test-owner`

**Context** show

**Parameters** *test-name* — Name of the SAA test. The test name must already be configured in the `config>saa>test` context.

*owner test-owner* — Specifies the owner of an SAA operation up to 32 characters in length.

**Default** If a *test-owner* value is not specified, tests created by the CLI have a default owner “TiMOS CLI”.

**Output** **Testhead Output** — The following table provides “testhead test-me owner owner-me” field descriptions.

Label	Description
Owner	Displays the owner of the test.
Name	Displays the name of the test.
Description	Displays the description for the test type.
Profile Id	Displays the associated profile ID.
Accept. Crit. Id	Displays the test acceptance criteria ID to be used by the testhead OAM tool to declare the PASS/FAIL result at the completion of the test.
Frame Payload Id	Displays frame payload ID, that determines the frame content of the frames generated by the tool.
Frame Payload Type	Displays the type of frame payload to be used in frames generated by testhead tool.
Color Aware Test	Displays if color aware tests need to be executed.

## OAM testhead commands

Label	Description (Continued)
SAP	Displays the SAP ID configured.
Completed	Displays if the test has been completed.
Stopped	Displays if the test has been stopped.
FC	Displays the forwarding class (FC) to use to send the frames generated by the testhead tool.
Start Time	Displays the start time of the test.
End Time	Displays the end time of the test.
Total time taken	Displays the total time taken to execute the test.
total pkts in us	Displays the total packets in microseconds.
OutPrf pkts in us	Displays the out-of-profile packets in microseconds.
InPrf pkts in us	Displays the in-profile packets in microseconds.
Total Injected	Displays the running count of total injected packets, including marker packets.
Total Received	Displays the running count of total received packets, including marker packets.
OutPrf Injected	Displays the running count of total out-of-profile packets, excluding marker packets.
OutPrf Received	Displays the running count of total out-of-profile packets received, including marker packets.
InPrf Injected	Displays the running count of total in-profile packets, excluding marker packets.
InPrf Received	Displays the running count of total in-profile packets received, including marker packets.
Throughput Configd	Displays the CIR Throughput rate Threshold Configured (in Kbps).
Throughput Oper	Displays the operational rate used for the configured rate. Operational rate is arrived considering the adaptation rule configured by the user and supported hardware rate.
Throughput Measurd	Displays the CIR Throughput Measured Value (in Kbps).
PIR Tput Threshld	Displays the PIR Throughput rate Threshold Configured (in Kbps).

Label	Description (Continued)
PIR Tput Meas	Displays the PIR Throughput rate Measured Value (in Kbps).
FLR Configured	Displays the Frame Loss Ratio Threshold Configured (in-profile).
FLR Measurd	Displays the Frame Loss Ratio Measured (in-profile).
FLR Acceptance	Displays Pass, Fail, or Not Applicable. It displays Pass, if the measured value is less than or equal to the configured threshold and displays "Fail" otherwise, and displays "Not Applicable", if the FLR criteria is not used to determine whether the test is in Passed or Failed status.
OutPrf FLR Conf	Displays the out-of-profile Frame Loss Ratio configured.
OutPrf FLR Meas	Displays the out-of-profile Frame Loss Ratio measured.
OutPrf FLR Acep	Displays Pass, Fail, or Not Applicable. It displays Pass, if the measured value is less than or equal to the configured threshold and displays "Fail" otherwise, and displays "Not Applicable", if the out-of-profile FLR criteria is not used to determine whether the test is in Passed or Failed status.
InPrf FLR Conf	Displays the in-profile Frame Loss Ratio configured.
InPrf FLR Meas	Displays the in-profile Frame Loss Ratio measured.
InPrf FLR Acep	Displays Pass, Fail, or Not Applicable. It displays Pass, if the measured value is less than or equal to the configured threshold and displays "Fail" otherwise, and displays "Not Applicable", if the in-profile FLR criteria is not used to determine whether the test is in Passed or Failed status.
Latency Con- figd(us)	Displays the Latency Threshold configured (in microseconds)
Latency Mea- surd(us)	Displays the Average Latency measured (in microseconds)
Latency Accep- tance	Displays Pass, Fail, or Not Applicable. It displays Pass, if the measured value is less than or equal to the configured threshold and displays "Fail" otherwise, and displays "Not Applicable", if the latency criteria is not used to determine whether the test is in Passed or Failed status.
OutPrf Lat Conf(us)	Displays the out-of-profile latency configured.
OutPrf Lat Meas(us)	Displays the out-of-profile latency measured.

## OAM testhead commands

Label	Description (Continued)
OutPrf Lat Acep	Displays Pass, Fail, or Not Applicable. It displays Pass, if the measured value is less than or equal to the configured threshold and displays "Fail" otherwise, and displays "Not Applicable", if the out-of-profile latency criteria is not used to determine whether the test is in Passed or Failed status.
InPrf Lat Conf(us)	Displays the in-profile latency configured.
InPrf Lat Meas(us)	Displays the in-profile latency measured.
InPrf Lat Acep	Displays Pass, Fail, or Not Applicable. It displays Pass, if the measured value is less than or equal to the configured threshold and displays "Fail" otherwise, and displays "Not Applicable", if the in-profile latency criteria is not used to determine whether the test is in Passed or Failed status.
Jitter Con- figd(us)	Displays the Jitter Threshold Configured (in microseconds).
Jitter Mea- surd(us)	Displays the Jitter Measured (in microseconds).
Jitter Accep- tance	Displays Pass, Fail, or Not Applicable. It displays Pass, if the measured value is less than or equal to the configured threshold and displays "Fail" otherwise, and displays "Not Applicable", if the jitter criteria is not used to determine whether the test is in Passed or Failed status.
OutPrf Jit Conf(us)	Displays the out-of-profile Jitter configured.
OutPrf Jit Meas(us)	Displays the out-of-profile Jitter measured.
OutPrf Jit Acep	Displays Pass, Fail, or Not Applicable. It displays Pass, if the measured value is less than or equal to the configured threshold and displays "Fail" otherwise, and displays "Not Applicable", if the out-of-profile jitter criteria is not used to determine whether the test is in Passed or Failed status.
InPrf Jit Conf(us)	Displays the in-profile Jitter configured.
InPrf Jit Meas(us)	Displays the in-profile Jitter measured.

Label	Description (Continued)
InPrf Jit Acep	Displays Pass, Fail, or Not Applicable. It displays Pass, if the measured value is less than or equal to the configured threshold and displays "Fail" otherwise, and displays "Not Applicable", if the in-profile jitter criteria is not used to determine whether the test is in Passed or Failed status.
Total Pkts. Tx.	Total number of packets ( that is, data and marker) transmitted by the testhead session for the duration of the test.
OutPrf Latency Pkt*	Total number of out-of-profile marker packets received by the testhead session for the duration of the test.
Total Tx. Fail	Total number of failed transmission attempts by the testhead session for the duration of the test.
Latency Pkts. Tx	Total number of marker packets transmitted by the testhead session for the duration of the test.
InPrf Latency Pkt*	Total number of in-profile marker packets received by the testhead session for the duration of the test.

**Sample output**

```
*A:7210SAS# show testhead test-me owner owner-me

=====
Y.1564 Testhead Session
=====
Owner           : owner-me
Test            : test-me
Profile Id      : 1                SAP           : 1/1/2:100
Accept. Crit. Id : 0                Completed      : Yes
Frame Payload Id : 1                Stopped        : No
Frame Payload Type : tcp-ipv4          FC             : be
Color Aware Test : Yes
Start Time      : 08/08/2001 19:37:11
End Time        : 08/08/2001 19:40:16
Total time taken : 0d 00:03:05

-----
Latency Results
-----
(total pkts in us):      Min      Max      Average      Jitter
Roundtrip :              0        0          0          0

(OutPrf pkts in us):    Min      Max      Average      Jitter
Roundtrip :              0        0          0          0

(InPrf pkts in us):     Min      Max      Average      Jitter
Roundtrip :              0        0          0          0

-----
Packet Count
```

## OAM testhead commands

-----  
Total Injected : 42273637  
Total Received : 0

OutPrf Injected : 16898179  
OutPrf Received : 0

InPrf Injected : 25375450  
InPrf Received : 0

-----  
Test Compliance Report  
-----

Throughput Configd : 962388  
Throughput Oper : 962384  
Throughput Measurd : 0

PIR Tput Threshld : Not configured  
PIR Tput Meas : 0

CIR Tput Threshld : Not configured  
CIR Tput Meas : 0

FLR Configured : None  
FLR Measurd : Not Applicable  
FLR Acceptance : Fail

OutPrf FLR Conf : None  
OutPrf FLR Meas : Not Applicable  
OutPrf FLR Acep : Not Applicable

InPrf FLR Conf : None  
InPrf FLR Meas : Not Applicable  
InPrf FLR Acep : Not Applicable

Latency Configd(us): None  
Latency Measurd(us): None  
Latency Acceptance : Not Applicable

OutPrf Lat Conf(us): None  
OutPrf Lat Meas(us): None  
OutPrf Lat Acep : Not Applicable

InPrf Lat Conf(us) : None  
InPrf Lat Meas(us) : None  
InPrf Lat Acep : Not Applicable

Jitter Configd(us) : None  
Jitter Measurd(us) : None  
Jitter Acceptance : Not Applicable

OutPrf Jit Conf(us): None  
OutPrf Jit Meas(us): None  
OutPrf Jit Acep : Not Applicable

InPrf Jit Conf(us) : None  
InPrf Jit Meas(us) : None  
InPrf Jit Acep : Not Applicable

## OAM and SAA Command Reference

```
Total Pkts. Tx.      : 13                Latency Pkts. Tx. : 8
OutPrf Latency Pkt* : 0                InPrf Latency Pkt* : 0
Total Tx. Fail      : 0
=====
*A:7210SAS# show testhead test-me  owner owner-me
```

## Clear Commands

### saa

**Syntax** `saa-test [test-name [owner test-owner]]`

**Context** clear

**Description** Clear the SAA results for the latest and the history for this test. If the test name is omitted, all the results for all tests are cleared.

**Parameters** *test-name* — Name of the SAA test. The test name must already be configured in the `config>saa>test` context.

*owner test-owner* — Specifies the owner of an SAA operation up to 32 characters in length.

**Default** If a *test-owner* value is not specified, tests created by the CLI have a default owner “TiMOS CLI”.

### test-oam

**Syntax** `test-oam`

**Context** clear

**Description** Clears the Operations, Administration, and Maintenance test parameters

### twamp server

**Syntax** `twamp server`

**Context** clear>test-oam

**Description** Clear TWAMP server statistics.

### testhead

**Syntax** `testhead result [ test-name ] [owner test-owner]`

**Context** oam>clear

**Description** Clear the testhead results identified by the test-name and test-owner.

- Parameters** *result* — Clears the test results from the latest history for the test.  
*test-name* — Name of the test
- Values** ASCII string upto 32 characters in length
- owner test-owner* — Specifies the owner of a testhead operation.
- Values** ASCII string upto 32 characters in length

## testhead

- Syntax** `testhead testhead-profile profile-id`
- Context** `oam>clear`
- Description** Clear the testhead results identified by the testhead-profile.
- Parameters** *testhead-profile profile-id* — Clears the testhead profile ID to use with this run/session of testhead invocation.
- Values** [1..10]



---

## Tools Command Reference

---

### Command Hierarchies

- [Tools Dump Commands on page 303](#)
- [Tools Perform Commands on page 305](#)

### Configuration Commands

#### Tools Dump Commands

- tools**
  - **dump**
    - **accounting-policy** *acct-policy-id* **flash-write-count** [**clear**]
    - **eth-ring** *ring-index* [**clear**]
    - **eth-ring** **control-sap-tag** *port-id* [**list-in-use**|**next-available**] (Supported only on 7210 SAS-X)
    - **lag** **lag-id** *lag-id*
    - **redundancy**
      - **multi-chassis**
        - **mc-endpoint** **peer** *ip-address*
        - **sync-database** [**peer** *ip-address*] [**port** *port-id* | *lag-id*] [**sync-tag** *sync-tag*] [**application** *application*] [**detail**] [**type** *type*]
  - **router** *router-instance*
    - **dintf** [*ip-address*]
    - **filter-info** [*verbose*]
    - **l3info**
    - **l3-stats** [*clear*]
    - **service-name** *service-name*
    - **ldp**
      - **fec** **prefix** *ip-prefix/mask*
      - **fec** **vc-type** {*vc-type*} **agi** *agi*
      - **fec** **vc-type** {*ethernet*|*vlan*} **vc-id** *vc-id*
      - **instance**
      - **interface** [*ip-int-name* | *ip-address*]
      - **memory-usage**
      - **peer** *ip-address*
      - **session** [*ip-addr[:label-space]*] [**connection**|**peer**|**adjacency**]
      - **sockets**
      - **timers**
  - **mpls**
    - **ospf** **to** *ip-addr* [**from** *ip-addr*] [**strict-srlg**] [**srlg-group** *grp-id...*(up to 8 max)] [**bandwidth** *bandwidth*] [**include-bitmap** *bitmap*] [**exclude-bitmap** *bitmap*] [**hop-limit** *limit*] [**exclude-address** *excl-addr* [*excl-addr...*(upto 8 max)]] [**use-te-metric**] [**exclude-node** *excl-node-id* [*excl-node-id...*(upto 8 max)]] [**skip-interface** *interface-name*]
    - **force-switch-path** **lsp** *lsp-name* **path** *path-name*
    - **no force-switch-path** **lsp** *lsp-name*

- **ftn** [endpoint *endpoint* | sender *sender* | nexthop *nexthop* | lsp-id *lsp-id* | tunnel-id *tunnel-id* | label *start-label end-label*]
- **ilm** [endpoint *endpoint* | sender *sender* | nexthop *nexthop* | lsp-id *lsp-id* | tunnel-id *tunnel-id* | label *start-label end-label*]
- **lspinfo** [*lsp-name*] [detail]
- **memory-usage**
- **resignal** lsp *lsp-name* path *path-name* delay *minutes*
- **resignal** { p2mp-lsp *p2mp-lsp-name* p2mp-instance *p2mp-instance-name* | p2mp-delay *p2mp-minutes* }
- **te-lspinfo** [endpoint *ip-address*] [sender *ip-address*] [lspid *lsp-id*] [detail]
- **te-lspinfo** [endpoint *ip-address*] [sender *ip-address*] [lspid *lsp-id*] [detail] switch-path lsp *lsp-name* path *path-name*
- **tp-tunnel**
  - **clear** { *lsp-name* | id *tunnel-id* }
  - **force** { *lsp-name* | id *tunnel-id* }
  - **manual** { *lsp-name* | id *tunnel-id* }
  - **lockout** { *lsp-name* | id *tunnel-id* }
- **trap-suppress** *number-of-traps* *time-interval*
- **memory-usage** lsp *lsp-name* path *path-name* new-path *path-name*
- **ospf** *ospf-instance*
  - **abr** [detail]
  - **asbr** [detail]
  - **bad-packet** *interface-name*
  - **leaked-routes** [summary | detail]
  - **memory-usage** [detail]
  - **request-list** [neighbor *ip-address*] [detail]
  - **request-list** virtual-neighbor *ip-address* area-id *area-id* [detail]
  - **retransmission-list** [neighbor *ip-address*] [detail]
  - **retransmission-list** virtual-neighbor *ip-address* area-id *area-id* [detail]
  - **route-summary**
  - **route-table** *ip-prefix/mask* [type] [detail]
- **ospf3**
- **rsvp**
  - **psb** [endpoint *endpoint-address*] [sender *sender-address*] [tunnelid *tunnel-id*] [lspid *lsp-id*]
  - **rsb** [endpoint *endpoint-address*] [sender *sender-address*] [tunnelid *tunnel-id*] [lspid *lsp-id*]
  - **tcsb** [endpoint *endpoint-address*] [sender *sender-address*] [tunnelid *tunnel-id*] [lspid *lsp-id*]
  - **neighbor** [*ip-address*] [detail]
- **service**
  - **base-stats** [clear]
  - **dpipe** *service-id*
  - **dtls** *service-id*
  - **iom-stats** [clear]
  - **l2pt-diags**
  - **l2pt-diags** clear
  - **l2pt-diags** detail
  - **vpls-fdb-stats** [clear]
  - **vpls-mfib-stats** [clear]
- **system**
  - **cpu-pkt-stats**
- **system-resources** *slot-number*
- **system-resources** *sap-ingress-qos*

## Tools Perform Commands

- tools**
  - **perform**
    - **cron**
    - **action**
      - **stop** *[action-name]* [**owner** *action-owner*] [**all**]
    - **tod**
      - **re-evaluate**
        - **customer** *customer-id* [**site** *customer-site-name*]
        - **filter ip-filter** [*filter-id*]
        - **filter ipv6-filter** [*filter-id*]
        - **filter mac-filter** [*filter-id*]
        - **service id** *service-id* [**sap** *sap-id*]
        - **tod-suite** *tod-suite-name*
  - **eth-ring**
    - **clear** *ring-index*
    - **force** *ring-index* **path** {**a**|**b**}
    - **manual** *ring-index* **path** {**a**|**b**}
  - **lag**
    - **clear-force** **all-mc**
    - **clear-force lag-id** *lag-id* [**sub-group** *sub-group-id*]
    - **clear-force peer-mc** *ip-address*
    - **force** **all-mc** {**active** | **standby**}
    - **force lag-id** *lag-id* [**sub-group** *sub-group-id*] {**active** | **standby**}
    - **force peer-mc** *peer-ip-address* {**active** | **standby**}
  - **log**
  - **test-event**
  - **router** [*router-instance*]
    - **isis** (Not supported on 7210 SAS-M device configured in Access uplink mode)
    - **mpls** (Not supported on 7210 SAS-M device configured in Access uplink mode)
      - **cspf to ip-addr** [**from** *ip-addr*] [**bandwidth** *bandwidth*] [**include-bitmap** *bitmap*] [**exclude-bitmap** *bitmap*] [**hop-limit** *limit*] [**exclude-address** *excl-addr* [*excl-addr...*(up to 8 max)]] [**use-te-metric**] [**skip-interface** *interface-name*]
      - **resignal lsp** *lsp-name* **path** *path-name* **delay** *minutes*
      - **trap-suppress** *number-of-traps* *time-interval*
    - **ospf** [*ospf-instance*] (Not supported on 7210 SAS-M device configured in Access uplink mode)
      - **ldp-sync-exit**
      - **refresh-lsas**
      - **run-manual-spf**
    - **ospf3**
      - **ldp-sync-exit**
      - **refresh-lsas**
      - **run-manual-spf**
  - **service**
    - **eval-pw-template** *policy-id* [**allow-service-impact**]
    - **id** *service-id*
      - **endpoint** *endpoint-name*
        - **force-switchover** *sdp-id:vc-id*
        - **no force-switchover**
      - **eval-pw-template** *policy-id* [**allow-service-impact**]

- **pw-routing**
  - **eval-expired-fec** *spoke-sdp-fec-id*
  - **eval-expired-fec** **all**
- **spoke-sdp-fec-release** *global-id[:prefix[:ac-id]]*

---

## Tools Configuration Commands

---

### Generic Commands

#### tools

**Syntax** tools

**Context** root

**Description** This command enables the context to enable useful tools for debugging purposes.

**Default** none

**Parameters** **dump** — Enables dump tools for the various protocols.

**perform** — Enables tools to perform specific tasks.

---

## Dump Commands

### dump

<b>Syntax</b>	<b>dump</b> <i>router-name</i>
<b>Context</b>	tools
<b>Description</b>	The context to display information for debugging purposes.
<b>Default</b>	none
<b>Parameters</b>	<i>router-name</i> — Specify a router name, up to 32 characters in length. <b>Default</b> Base

### accounting-policy

<b>Syntax</b>	accounting-policy <i>acct-policy-id</i> <b>flash-write-count</b> [clear]
<b>Context</b>	tools>dump
<b>Description</b>	The above command dumps the total count of flash writes for the accounting policy specified by the user. The 'clear' option allows the user to clear the count maintained per accounting policy and starts the counter afresh.
<b>Parameters</b>	<b>flash-write-count</b> — This is a keyword used to dump the total number of flash writes up to the present for the accounting policy specified by accounting-policy 'id'. <i>acct-policy-id</i> — Identifies the Accounting policy. <b>Values</b> 1 - 99 <b>clear</b> — This keyword clears statistics.

### eth-ring

<b>Syntax</b>	eth-ring <i>ring-index</i> [clear] <b>eth-ring control-sap-tag</b> <i>port-id</i> [ <b>list-in-use</b>   <b>next-available</b> ] (Supported only on 7210 SAS-X)
<b>Context</b>	tools>dump
<b>Description</b>	The command displays Ethernet-ring information.
<b>Parameters</b>	<i>ring-index</i> — Specify ring index. <b>Values</b> 1 —128 <b>clear</b> — This keyword clears statistics.

## eth-ring

**Syntax** **eth-ring control-sap-tag** *port-id* [**list-in-use**|**next-available**] (Supported only on 7210 SAS-X)

**Context** tools>dump

**Description** This command allows the user to list the VLAN IDs on the given port in use as G.8032 control SAP tags using the 'list-in-use' option. These VLAN IDs cannot be used with any other SAP on the same port (even the Default SAP, will not receive packets with this VLAN ID).

User can obtain the next available VLAN ID to use as a control SAP tag using the 'next-available' option. This option returns a VLAN ID, after ensuring the following:

- The VLAN ID is in the range of VLAN IDs reserved for G.8032 control SAP tags.
- The VLAN ID is not being used by any service SAP on the same port.
- This VLAN ID is not being used as a control-sap-tag on any other eth-ring instance configured on the same port.

**Parameters** *port-id* — Specify the port ID.

**Values** slot/mda/port

**list-in-use** — Lists the in-use control SAP VLAN IDs on the port.

**next-available** — Lists the next available VLAN ID which can be used as control SAP TAG.

## lag

**Syntax** **lag** lag-id *lag-id*

**Context** tools>dump

**Description** This tool displays LAG information.

**Parameters** *lag-id* — Specify an existing LAG id.

**Values** 1 — 12

```
*A:kiran3>tools>dump# lag lag-id 1
```

```
Port state      : Up
Selected subgrp : 1
NumActivePorts  : 2
ThresholdRising : 2
ThresholdFalling: 0
IOM bitmask     : 2
Config MTU      : 1522
Oper. MTU       : 1522
Bandwidth       : 200000
```

```
multi-chassis   : NO
```

```
-----
Indx  PortId  RX pkts  TX pkts  State Active Port  Cfg Oper Speed  BW AP CS
      Pri  Mtu Mtu
-----
0     1/1/1    1        1     Up  yes 32768 1522 1522 1000 100000 0 2
-----
```

## Dump Commands

1 1/1/2 0 0 Up yes 32768 1522 1522 1000 100000 0 2

### eth-ring

**Syntax** eth-ring *ring-index* [**clear**]

**Context** tools>dump

**Description** This tool displays eth-ring information.

**Parameters** *ring-index* — Specifies the ring index.

**Values** 1 — 128

*clear* — Clears the eth-ring statistics.

### redundancy

**Syntax** redundancy

**Context** tools>dump

**Description** This command enables the context to dump tools for redundancy.

### multi-chassis

**Syntax** multi-chassis

**Context** tools>dump>redundancy>multi-chassis

**Description** This command enables the context to dump tools for multi-chassis redundancy.

### mc-endpoint

**Syntax** multi-chassis

**Context** tools>dump>redundancy>multi-chassis

**Description** This command dumps multi-chassis endpoint information.

**Parameters** *peer ip-address* — Specifies the peer's IP address.

## sync-database

**Syntax** **sync-database** [**peer** *ip-address*] [**port** *port-id* | *lag-id*] [**sync-tag** *sync-tag*] [**application** *application*] [**detail**] [**type** *type*]

**Context** tools>dump>redundancy>multi-chassis

**Description** This command dumps MCS database information.

**peer** *ip-address* — Specifies the peer's IP address.

**port** *port-id* | *lag-id* — Indicates the port or LAG ID to be synchronized with the multi-chassis peer.

**Values** *slot/mda/port* or *lag-lag-id*

**sync-tag** *sync-tag* — Specifies a synchronization tag to be used while synchronizing this port with the multi-chassis peer.

**application** *application* — Specifies a particular multi-chassis peer synchronization protocol application.

**Values**

igmp-snooping:	igmp-snooping
mc-ring:	multi-chassis ring
sub-host-trk:	subscriber host tracking

**type** *type* — Indicates the locally deleted or alarmed deleted entries in the MCS database per multi-chassis peer.

**Values** alarm-deleted, local-deleted

**detail** — Displays detailed information.

## system

**Syntax** **cpu-pkt-stats**

**Context** tools>dump>system

**Description** This command dumps tools for system information.

## cpu-pkt-stats

**Syntax** **cpu-pkt-stats**

**Context** tools>dump>system

**Description** This command dumps statistics for CPU traffic.

## system-resources

**Syntax** **system-resources** *slot-number*  
**system-resources** *sap-ingress-qos*  
**system-resources** *slot-number* **g8032-control-sap-tags**

**Context** tools>dump

**Description** This command displays system resource information.

**Default** none

**Parameters** *slot-number* — Specify a specific slot to view system resources information.

**Values** 1

*sap-ingress-qos* — This command provides details on usage of resources allocated for QoS classification and different match criteria under QoS classification.

### Sample Output

**tools dump system-resources sap-ingress-qos** — The following table describes tools dump system-resource sap-ingress-qos output fields:

**Table 16: Output fieldstools dump system-resource sap-ingress-qos**

Labels	Descriptions
Total Chunks Configured	Displays the total number of chunks configured for use by SAP ingress QoS classification across all the match criteria.
Total Chunks Available	Displays the total number of chunks allotted by software for use by SAP ingress QoS classification across all the match criteria.
Number of Chunks in Use	Displays the total number of chunks in use by SAP for SAP ingress QoS classification.
Number of Free Chunks	Displays the total number of chunks available for use by SAP for SAP ingress QoS classification.
Number of Chunks in use for IP match	Displays the total number of chunks in use for by SAP that use IP classification match criteria in the SAP ingress QoS policy.
Number of Chunks in use for IPv6 match	Displays the total number of chunks in use for by SAP that use IPv6 classification match criteria in the SAP ingress QoS policy.

**Table 16: Output fieldstools dump system-resource sap-ingress-qos**

Labels	Descriptions
Number of Chunks in use for MAC match	Displays the total number of chunks in use for by SAP that use MAC classification match criteria in the SAP ingress QoS policy.
Classification Entries	The total number of Classification entries that are available/allocated/free per chunk. Information is displayed only for chunks that are in use. <b>Meters</b> - The total number of Meters that are available/allocated/free per chunk. Information is displayed only for chunks that are in use.
Number of Chunks available for use with IP match criteria	Displays the total number of chunks in use for by SAP that use IP classification match criteria in the SAP ingress QoS policy. This assumes all of the free chunks are allotted to IP classification match criteria.
Number of Chunks available for use with IPv6 match criteria	Displays the total number of chunks in use for by SAP that use IPv6 classification match criteria in the SAP ingress QoS policy. This assumes all of the free chunks are allotted to IPv6 classification match criteria.
Number of Chunks available for use with MAC match criteria	Displays the total number of chunks in use for by SAP that use MAC classification match criteria in the SAP ingress QoS policy. This assumes all of the free chunks are allotted to MAC classification match criteria.

```
*A:7210-SAS>tools>dump# system-resources tools dump system-resources sap-ingress-qos
Sap Resource Manager info at 001 d 10/11/12 04:42:00.043:
```

```
Sap Ingress Resource Usage for Slot #1, Cmplx #0:
```

```
Total Chunks Configured : 6
Total Chunks Available : 6
Number of Chunks in Use : 1
Number of Free Chunks : 5
Number of Chunks in use for IP match : 0
Number of Chunks in use for IPv6 match : 0
Number of Chunks in use for MAC match : 1
```

Chunk	Type	Classification Entries			Meters		
		Total	Allocated	Free	Total	Allocated	Free
0	Mac	512	2	510	256	1	255

```
Number of Chunks available for use with IP match* : 5
Number of Chunks available for use with IPv6 match* : 0
Number of Chunks available for use with MAC match* : 5
```

\* - Assumes all remaining chunks are used

## Dump Commands

```
*A:Dut-A>tools>dump#
```

**The following sample displays the resource utilization for SAP egress aggregate meter on 7210 SAS-M and 7210 SAS-T:**

```
*7210SAS>config>service# /tools dump system-resources  
Resource Manager info at 022 h 07/27/01 22:50:44.676:
```

Hardware Resource Usage per Node:

	Total	Allocated	Free
Max System Ecmp Routes		1	

Hardware Resource Usage for Slot #1, CardType iom-sas, Cmplx #0:

	Total	Allocated	Free
SAP Ingress QoS Policies	1791	1	1790
Access Egr. QoS Policies	255	1	254
SAP Ingress Aggregate-Meter	256	0	256
Shared Qos Ingress Meters	1280	256	1024
Shared Qos Ingress CAM Entries	2560	512	2048
Mac Qos Ingress Meters	256	2	254
Mac Qos Ingress CAM Entries	512	4	508
IPv4 Qos Ingress Meters	0	0	0
IPv4 Qos Ingress CAM Entries	0	0	0
IPv6 Qos Ingress Meters	0	0	0
IPv6 Qos Ingress CAM Entries	0	0	0
IP + Mac Qos Ingress Meters	0	0	0
IP + Mac Qos Ingress CAM Entries	0	0	0
SAP Egress Aggregate-Meter Entries	512	2	510
Network Ingress Meters	256	0	256
Network Ing CAM Entries	512	0	512
Port Scheduler Policies	1023	1	1022
Ingress Shared ACL Entries	2560	0	2560
Ingress Mac ACL Entries	0	0	0
Ingress IPv4 ACL Entries	0	0	0
Ing IPv6 128 bit ACL Entries	0	0	0
Ing IPv6 64 bit ACL Entries	0	0	0
Egress Shared ACL Entries	0	0	0
Egress Mac only ACL Entries	0	0	0
Egress Mac+IPv4 ACL Entries	0	0	0
Egr IPv6 128 bit ACL Entries	0	0	0
Egr Mac+IPv6 64 bit ACL Entries	0	0	0
Ingress SAP Lookup Entries	1496	4	1492
Num VLAN-ID/Range in Con Profile	4096	0	4096

**The following sample displays the resource utilization for SAP egress aggregate meter on 7210 SAS-R6:**

```
A:7210SAS-053>tools>dump# system-resources  
Resource Manager info at 001 h 02/29/16 10:03:45.035:
```

Hardware Resource Usage per Node:

	Total	Allocated	Free
Max System Ecmp Routes		1	
Ldp Ecmp percent value		0	
Eth-Ring Fast Flood Entries	1280	1	1279

Hardware Resource Usage for Slot #1, CardType imm-sas-b-10sfp-1sfp+, Cmplx #0:

	Total	Allocated	Free
SAP Ingress QoS Policies	1791	2	1789
Access Egr. QoS Policies	255	2	253
SAP Egress QoS Policies	2047	2	2045
SAP Ingress Aggregate-Meter	384	0	384
Shared Qos Ingress Meters	640	128	512
Shared Qos Ingress CAM Entries	1280	256	1024
Mac Qos Ingress Meters	128	6	122
Mac Qos Ingress CAM Entries	256	12	244
IPv4 Qos Ingress Meters	0	0	0
IPv4 Qos Ingress CAM Entries	0	0	0
IPv6 Qos Ingress Meters	0	0	0
IPv6 Qos Ingress CAM Entries	0	0	0
IP + Mac Qos Ingress Meters	0	0	0
IP + Mac Qos Ingress CAM Entries	0	0	0
SAP Egress Agg-Meter Entries	0	0	0
Network Ing Port Meters	128	10	118
Network Ing Port CAM Entries	256	10	246
Network Ing IpIntf Meters	128	4	124
Network Ing IpIntf CAM Entries	256	4	252
Network MPLS Exp Profile Table	31	0	31
Port Scheduler Policies	0	0	0
Queue Management Policies	500	1	499
Remark Policies	256	5	251
Shared Egr QOS MAP Entries	14	1	13
Egress QOS CAM Entries	400	6	394
Ingress Shared ACL Entries	768	0	768
Ingress Mac ACL Entries	0	0	0
Ingress IPv4 ACL Entries	0	0	0
Ing IPv6 128 bit ACL Entries	0	0	0
Ing IPv6 64 bit ACL Entries	0	0	0
Egress Shared ACL Entries	128	0	128
Egress Mac only ACL Entries	0	0	0
Egress Mac+IPv4 ACL Entries	0	0	0
Egr IPv6 128 bit ACL Entries	0	0	0
Egr Mac+IPv6 64 bit ACL Entries	0	0	0
Ingress SAP Lookup Entries	706	8	698
Egress Sap Counter Entries	127	0	127
MEP Lookup CAM Entries	256	0	256
DN MEP Entries	256	38	218
Port Scheduler Mode	0		
Num VLAN-ID/Range in Con Profile	4096	0	4096

## Service Commands

### service

**Syntax** `service`

**Context** `tools>dump`

**Description** Use this command to configure tools to display service dump information.

### base-stats

**Syntax** `base-stats [clear]`

**Context** `tools>dump>service`

**Description** Use this command to display internal service statistics.

**Default** `none`

**Parameters** `clear` — Clears stats after reading.

### dpipe

**Syntax** `dpipe service-id`

**Context** `tools>dump>service`

**Description** This command displays debug information for specified service.

**Parameters** `service-id` — Displays specified service ID details.

**Values** 1 - 2147483647

### dtls

**Syntax** `dtls service-id`

**Context** `tools>dump>service`

**Description** Use this command to display TLS service statistics.

**Default** `none`

**Parameters** `service-id` — Displays specified service ID details.

## iom-stats

<b>Syntax</b>	<b>iom-stats [clear]</b>
<b>Context</b>	tools>dump>service
<b>Description</b>	Use this command to display IOM message statistics.
<b>Default</b>	none
<b>Parameters</b>	<b>clear</b> — Clears stats after reading.

## l2pt-diags

<b>Syntax</b>	<b>l2pt-diags</b> <b>l2pt-diags clear</b> <b>l2pt-diags detail</b>
<b>Context</b>	tools>dump>service
<b>Description</b>	Use this command to display L2pt diagnostics.
<b>Default</b>	none
<b>Parameters</b>	<b>clear</b> — Clears the diags after reading. <b>detail</b> — Displays detailed information.

**Sample Output**

```
A:ALA-48>tools>dump>service# l2pt-diags
[ l2pt/bpdu error diagnostics ]
  Error Name          | Occurrence   | Event log
  -----+-----+-----
[ l2pt/bpdu forwarding diagnostics ]

  Rx Frames   | Tx Frames   | Frame Type
  -----+-----+-----
A:ALA-48>tools>dump>service#

A:ALA-48>tools>dump>service# l2pt-diags detail
[ l2pt/bpdu error diagnostics ]
  Error Name          | Occurrence   | Event log
  -----+-----+-----
[ l2pt/bpdu forwarding diagnostics ]

  Rx Frames   | Tx Frames   | Frame Type
  -----+-----+-----
[ l2pt/bpdu config diagnostics ]
WARNING - service 700 has l2pt termination enabled on all access points :
         consider translating further down the chain or turning it off.
WARNING - service 800 has l2pt termination enabled on all access points :
         consider translating further down the chain or turning it off.
WARNING - service 9000 has l2pt termination enabled on all access points :
         consider translating further down the chain or turning it off.
WARNING - service 32806 has l2pt termination enabled on all access points :
```

## Service Commands

```
consider translating further down the chain or turning it off.  
WARNING - service 90001 has l2pt termination enabled on all access points :  
consider translating further down the chain or turning it off.  
A:ALA-48>tools>dump>service#
```

### vpls-fdb-stats

**Syntax** `vpls-fdb-stats [clear]`

**Context** `tools>dump>service`

**Description** Use this command to display VPLS FDB statistics.

**Default** none

**Parameters** `clear` — Clears stats after reading.

### vpls-mfib-stats

**Syntax** `vpls-mfib-stats [clear]`

**Context** `tools>dump>service`

**Description** Use this command to display VPLS MFIB statistics.

**Default** none

**Parameters** `clear` — Clears stats after reading.

---

## Router Commands

### router

<b>Syntax</b>	<b>router</b> <i>router-instance</i>
<b>Context</b>	tools>dump tools>perform
<b>Description</b>	This command enables tools for the router instance.
<b>Default</b>	none
<b>Parameters</b>	<b>router</b> <i>router-instance</i> — Specifies the router name or service ID.
	<b>Values</b> <i>router-name:</i> Base, management
	<b>Default</b> Base

### dintf

<b>Syntax</b>	<b>dintf</b> [ <i>ip-address</i> ]
<b>Context</b>	tools>dump>router
<b>Description</b>	This command displays the internal IP interface details.
<b>Parameters</b>	<i>ip-address</i> — Only displays the internal IP interface details.

### filter-info

<b>Syntax</b>	<b>filter-info</b> [ <b>verbose</b> ]
<b>Context</b>	tools>dump>router
<b>Description</b>	This command dumps the hardware-specific filter information.
<b>Parameters</b>	<b>verbose</b> — Displays the hardware information of the filter.

### l3info

<b>Syntax</b>	<b>lag</b>
<b>Context</b>	tools>dump>router
<b>Description</b>	This command dumps the hardware-specific L3 information.

## l3-stats

<b>Syntax</b>	<b>l3-stats [clear]</b>
<b>Context</b>	tools>dump>router
<b>Description</b>	This command dumps the hardware-specific L3 statistics.
<b>Parameters</b>	<b>clear</b> — Clears the hardware information of the filter.

## eth-ring

<b>Syntax</b>	eth-ring
<b>Context</b>	tools>perform
<b>Description</b>	This command configures tools to control Ethernet rings.

## clear

<b>Syntax</b>	<b>clear <i>ring-index</i></b>
<b>Context</b>	tools>perform>eth-ring
<b>Description</b>	This command removes all switching operational commands. The clear command is used for the following operations: <ul style="list-style-type: none"><li>• Clears an active local administrative command (for example the Force switch or Manual switch commands).</li><li>• Triggers reversion before the WTR or WTB timer expires in case of revertive operation.</li><li>• Triggers reversion in case of non-revertive operation.</li></ul>
<b>Parameters</b>	<i>ring-index</i> — Specifies the ring index of the Ethernet ring. <b>Values</b> 1—128

## force

<b>Syntax</b>	<b>force <i>ring-index</i> path {a b}</b>
<b>Context</b>	tools>perform>eth-ring
<b>Description</b>	This command forces the specified path into a blocked state.
<b>Parameters</b>	<i>ring-index</i> — Specifies the ring index of the Ethernet ring. <b>Values</b> 1—128 <b>path {a b}</b> — Specifies the path of the Ethernet ring.

## manual

**Syntax** `manual ring-index path {a|b}`

**Context** `tools>perform>eth-ring`

**Description** This command sets the specified eth-ring path into a blocked state.

**Parameters** *ring-index* — Specifies the ring index of the Ethernet ring.

**Values** 1—128

*path {a|b}* — Specifies the path of the Ethernet ring.

## lag

**Syntax** `lag`

**Context** `tools>perform`

**Description** This command configures tools to control LAG.

## clear-force

**Syntax** `clear-force lag-id lag-id [sub-group sub-group-id]`  
`clear-force all-mc`  
`clear-force peer-mc ip-address`

**Context** `tools>perform>lag`

**Description** This command clears a forced status.

**Parameters** *lag-id lag-id* — Specify an existing LAG id.

**Values** 1-200

*all-mc* — Clears all multi-chassis LAG information.

## force

**Syntax** `force lag-id lag-id [sub-group sub-group-id] {active | standby}`  
`force all-mc {active | standby}`  
`force peer-mc peer-ip-address {active | standby}`

**Context** `tools>perform>lag`

**Description** This command forces an active or standby status.

**Parameters** *active* — If *active* is selected, then all drives on the active CPM are forced.

*all-mc* — Clears all multi-chassis LAG information.

## Router Commands

**peer-mc** — Clears mutichassis LAG peer information.

**standby** — If **standby** is selected, then all drives on the standby CPM are forced.

**lag-id** *lag-id* — Specify an existing LAG id.

**Values** 1 — 6

### log

**Syntax** **log**

**Context** tools>perform

**Description** Tools for event logging.

### test-event

**Syntax** **test-event**

**Context** tools>perform>log

**Description** This command causes a test event to be generated. The test event is LOGGER event #2011 and maps to the tmnxEventSNMP trap in the TIMETRA-LOG-MIB.

### interface

**Syntax** **interface** [*ip-int-name* | *ip-address*]

**Context** tools>dump>router>ldp

**Description** This command displays information for an LDP interface.

**Default** none

**Parameters** *ip-int-name* — Specifies the interface name.

*ip-address* — Specifies the IP address.

### ldp

**Syntax** **ldp**

**Context** tools>dump>router

**Description** This command enables dump tools for LDP.

**Default** none

## peer

<b>Syntax</b>	<b>peer</b> <i>ip-address</i>
<b>Context</b>	tools>dump>router>ldp
<b>Description</b>	This command displays information for an LDP peer.
<b>Default</b>	none
<b>Parameters</b>	<i>ip-address</i> — Specifies the IP address.

## fec

<b>Syntax</b>	<b>fec prefix</b> [ <i>ip-prefix/mask</i> ] <b>fec vc-type</b> { <b>ethernet</b>   <b>vlan</b> } <b>vc-id</b> <i>vc-id</i>
<b>Context</b>	tools>dump>router>ldp
<b>Description</b>	This command displays information for an LDP FEC.
<b>Default</b>	none
<b>Parameters</b>	<i>ip-prefix/mask</i> — Specifies the IP prefix and host bits.

<b>Values</b>	host bits:	must be 0
	mask:	0 — 32

**vc-type** — Specifies the VC type signaled for the spoke or mesh binding to the far end of an SDP. The VC type is a 15 bit-quantity containing a value which represents the type of VC. The actual signaling of the VC type depends on the signaling parameter defined for the SDP. If signaling is disabled, the **vc-type** command can still be used to define the Dot1q value expected by the far-end provider equipment. A change of the binding's VC type causes the binding to signal the new VC type to the far end when signaling is enabled.

VC types are derived according to IETF *draft-martini-l2circuit-trans-mpls*.

- Ethernet — The VC type value for Ethernet is 0x0005.
- VLAN — The VC type value for an Ethernet VLAN is 0x0004.

*vc-id* — Specifies the virtual circuit identifier.

<b>Values</b>	1 — 4294967295
---------------	----------------

## instance

<b>Syntax</b>	<b>instance</b>
<b>Context</b>	tools>dump>router>ldp
<b>Description</b>	This command displays information for an LDP instance.

## memory-usage

<b>Syntax</b>	<b>memory-usage</b>
<b>Context</b>	tools>dump>router>ldp
<b>Description</b>	This command displays memory usage information for LDP.
<b>Default</b>	none

## session

<b>Syntax</b>	<b>session</b> [ <i>ip-address</i> [: <i>label space</i> ] [ <i>connection</i>   <i>peer</i>   <i>adjacency</i> ]
<b>Context</b>	tools>dump>router>ldp
<b>Description</b>	This command displays information for an LDP session.
<b>Default</b>	none
<b>Parameters</b>	<i>ip-address</i> — Specifies the IP address of the LDP peer. <i>label-space</i> — Specifies the label space identifier that the router is advertising on the interface. <b>connection</b> — Displays connection information. <b>peer</b> — Displays peer information. <b>adjacency</b> — Displays hello adjacency information.

## sockets

<b>Syntax</b>	<b>sockets</b>
<b>Context</b>	tools>dump>router>ldp
<b>Description</b>	This command displays information for all sockets being used by the LDP protocol.
<b>Default</b>	none

## timers

<b>Syntax</b>	<b>timers</b>
<b>Context</b>	tools>dump>router>ldp
<b>Description</b>	This command displays timer information for LDP.
<b>Default</b>	none

## mpls

<b>Syntax</b>	<b>mpls</b>
<b>Context</b>	tools>dump>router
<b>Description</b>	This command enables the context to display MPLS information.
<b>Default</b>	none

## ftn

<b>Syntax</b>	<b>ftn</b>
<b>Context</b>	tools>dump>router>mpls
<b>Description</b>	This command displays FEC-to-NHLFE (FTN) dump information for MPLS. (NHLFE is the acronym for Next Hop Label Forwarding Entry.)
<b>Default</b>	none

## ilm

<b>Syntax</b>	<b>ilm</b>
<b>Context</b>	tools>dump>router>mpls
<b>Description</b>	This command displays incoming label map (ILM) information for MPLS.
<b>Default</b>	none

## lspinfo

<b>Syntax</b>	<b>lspinfo</b> [ <i>lsp-name</i> ] [ <b>detail</b> ]
<b>Context</b>	tools>dump>router>mpls
<b>Description</b>	This command displays label-switched path (LSP) information for MPLS.
<b>Default</b>	none
<b>Parameters</b>	<p><i>lsp-name</i> — Specifies the name that identifies the LSP. The LSP name can be up to 32 characters long and must be unique.</p> <p><b>detail</b> — Displays detailed information about the LSP.</p>

## cspf

## Router Commands

**Syntax** **cspf to** *ip-addr* [**from** *ip-addr*] [**strict-srlg**] [**srlg-group** *grp-id...*(up to 8 max)] [**bandwidth** *bandwidth*] [**include-bitmap** *bitmap*] [**exclude-bitmap** *bitmap*] [**hop-limit** *limit*] [**exclude-address** *excl-addr* [*excl-addr...*(upto 8 max)]] [**use-te-metric**] [**exclude-node** *excl-node-id* [*excl-node-id...*(upto 8 max)]] [**skip-interface** *interface-name*]

**Context** tools>perform>router>mpls

**Description** This command computes a CSPF path with specified user constraints.

**Default** none

**Parameters** **to** *ip-addr* — Specify the destination IP address.

**from** *ip-addr* — Specify the originating IP address.

**srlg-group** *grp-id* — Specify the

**bandwidth** *bandwidth* — Specifies the amount of bandwidth in mega-bits per second (Mbps) to be reserved.

**include-bitmap** *bitmap* — Specifies to include a bit-map that specifies a list of admin groups that should be included during setup.

**exclude-bitmap** *bitmap* — Specifies to exclude a bit-map that specifies a list of admin groups that should be included during setup.

**hop-limit** *limit* — Specifies the total number of hops a detour LSP can take before merging back onto the main LSP path.

**exclude-address** *ip-addr* — Specifies an IP address to exclude from the operation.

**use-te-metric** — Specifies whether the TE metric would be used for the purpose of the LSP path computation by CSPF.

**skip-interface** *interface-name* — Specifies a local interface name, instead of the interface address, to be excluded from the CSPF computation.

## force-switch-path

**Syntax** **force-switch-path lsp** *lsp-name path path-name*  
**no force-switch-path lsp** *lsp-name*

**Context** tools>perform>router>mpls

**Description**

## resignal

**Syntax** **resignal lsp** *lsp-name path path-name delay minutes*

**resignal** {**p2mp-lsp** *p2mp-lsp-name* **p2mp-instance** *p2mp-instance-name* | **p2mp-delay** *p2mp-minutes*}

**Context** tools>perform>router>mpls

**Description** Use this command to resignal a specific LSP path.

**Default** none

**Parameters** **lsp** *lsp-name* — Specifies the name that identifies the LSP. The LSP name can be up to 32 characters long and must be unique.

**path** *path-name* — Specifies the name for the LSP path up to 32 characters in length.

**delay** *minutes* — Specifies the resignal delay in minutes.

**Values** 0 — 30

**p2mp-lsp** *p2mp-lsp-name* — Specifies an existing point-to-multipoint LSP name.

**p2mp-instance** *p2mp-instance-name* — Specifies a name that identifies the P2MP LSP instance

**p2mp-delay** *p2mp-minutes* — Specifies the delay time, in minutes.

**Values** 0 — 60

## switch-path

**Syntax** **switch-path lsp** *lsp-name path path-name*

**Context** tools>perform>router>mpls

**Description**

## trap-suppress

**Syntax** **trap-suppress** [*number-of-traps*] [*time-interval*]

**Context** tools>perform>router>mpls

**Description** This command modifies thresholds for trap suppression.

**Default** none

**Parameters** *number-of-traps* — Specify the number of traps in multiples of 100. An error message is generated if an invalid value is entered.

**Values** 100 to 1000

*time-interval* — Specify the timer interval in seconds.

**Values** 1 — 300

## tp-tunnel

**Syntax** **tp-tunnel**

**Context** tools>perform>router>mpls

**Description** This command enables the context to perform Linear Protection operations on an MPLS-TP LSP.

## clear

**Syntax** **clear** {*lsp-name* | **id** *tunnel-id*}

**Context** tools>perform>router>mpls>tp-tunnel

**Description** Clears all the MPLS-TP linear protection operational commands for the specified LSP that are currently active.

**Parameters** *lsp-name* — Specifies the name of the MPLS-TP LSP.

**Values** up to 32 characters in text

**id** *tunnel-id* — Specifies the tunnel number of the MPLS-TP LSP

**Values** 1 — 61440

## force

**Syntax** **force** {*lsp-name* | **id** *tunnel-id*}

**Context** tools>perform>router>mpls>tp-tunnel

**Description** Performs a force switchover of the MPLS-TP LSP from the active path to the protect path.

**Parameters** *lsp-name* — Specifies the name of the MPLS-TP LSP.

**Values** up to 32 characters in text

**id** *tunnel-id* — Specifies the tunnel number of the MPLS-TP LSP

**Values** 1 — 61440

## manual

**Syntax** **manual** {*lsp-name* | **id** *tunnel-id*}

**Context** tools>perform>router>mpls>tp-tunnel

**Description** Performs a manual switchover of the MPLS-TP LSP from the active path to the protect path.

**Parameters** *lsp-name* — Specifies the name of the MPLS-TP LSP.

**Values** up to 32 characters in text

**id** *tunnel-id* — Specifies the tunnel number of the MPLS-TP LSP

**Values** 1 — 61440

## lockout

**Syntax** **lockout** {*lsp-name* | **id** *tunnel-id*}

**Context** tools>perform>router>mpls>tp-tunnel

**Description** Performs a lockout of protection for an MPLS-TP LSP. This prevents a switchover to the protect path.

**Parameters** *lsp-name* — Specifies the name of the MPLS-TP LSP.

**Values** up to 32 characters in text

**id** *tunnel-id* — Specifies the tunnel number of the MPLS-TP LSP

**Values** 1 — 61440

## memory-usage

**Syntax** **memory-usage**

**Context** tools>dump>router>mpls

**Description** This command displays memory usage information for MPLS.

**Default** none

## te-lspinfo

**Syntax** **te-lspinfo** [**endpoint** *ip-address*] [**sender** *ip-address*] [**lspid** *lsp-id*] [**detail**]  
**te-lspinfo** [**endpoint** *ip-address*] [**sender** *ip-address*] [**lspid** *lsp-id*] [**detail**]

**Context** tools>dump>router>mpls

**Description** This command displays TE LSP information for MPLS.

**Default** none

## ospf

**Syntax** **ospf** [*ospf-instance*]

**Context** tools>dump>router

**Description** This command enables the context to display tools information for OSPF.

**CONFIGURATION NOTES:**

## Router Commands

- 7210 SAS-M network mode devices allow for configuration of a single instance at any given time. The instance ID can be anything other than zero. It allows 7210 SAS-M devices to be used in a network, where Multi-Instance OSPF is deployed and the node needs to use an instance ID other than the default instance ID of 0.
- Number of OSPF instances supported on different 7210 platforms are different. Kindly talk to a Nokia/Alcatel-Lucent representative to know the supported scaling limits.

**Default** none

**Parameters** **ospf-instance** — OSPF instance.

**Values** 0— 31

### abr

**Syntax** **abr [detail]**

**Context** tools>dump>router>ospf

**Description** This command displays area border router (ABR) information for OSPF.

**Default** none

**Parameters** **detail** — Displays detailed information about the ABR.

### asbr

**Syntax** **asbr [detail]**

**Context** tools>dump>router>ospf

**Description** This command displays autonomous system border router (ASBR) information for OSPF.

**Default** none

**Parameters** **detail** — Displays detailed information about the ASBR.

### bad-packet

**Syntax** **bad-packet [interface-name]**

**Context** tools>dump>router>ospf

**Description** This command displays information about bad packets for OSPF.

**Default** none

**Parameters** *interface-name* — Display only the bad packets identified by this interface name.

## leaked-routes

<b>Syntax</b>	<b>leaked-routes</b> [ <b>summary</b>   <b>detail</b> ]
<b>Context</b>	tools>dump>router>ospf
<b>Description</b>	This command displays information about leaked routes for OSPF.
<b>Default</b>	summary
<b>Parameters</b>	<b>summary</b> — Display a summary of information about leaked routes for OSPF. <b>detail</b> — Display detailed information about leaked routes for OSPF.

## memory-usage

<b>Syntax</b>	<b>memory-usage</b> [ <b>detail</b> ]
<b>Context</b>	tools>dump>router>ospf
<b>Description</b>	This command displays memory usage information for OSPF.
<b>Default</b>	none
<b>Parameters</b>	<b>detail</b> — Displays detailed information about memory usage for OSPF.

## request-list

<b>Syntax</b>	<b>request-list</b> [ <b>neighbor</b> <i>ip-address</i> ] [ <b>detail</b> ] <b>request-list</b> <b>virtual-neighbor</b> <i>ip-address</i> <b>area-id</b> <i>area-id</i> [ <b>detail</b> ]
<b>Context</b>	tools>dump>router>ospf
<b>Description</b>	This command displays request list information for OSPF.
<b>Default</b>	none
<b>Parameters</b>	<b>neighbor</b> <i>ip-address</i> — Display neighbor information only for neighbor identified by the IP address. <b>detail</b> — Displays detailed information about the neighbor. <b>virtual-neighbor</b> <i>ip-address</i> — Displays information about the virtual neighbor identified by the IP address. <b>area-id</b> <i>area-id</i> — The OSPF area ID expressed in dotted decimal notation or as a 32-bit decimal integer.

## retransmission-list

**Syntax** **retransmission-list** [**neighbor** *ip-address*] [**detail**]  
**retransmission-list virtual-neighbor** *ip-address area-id area-id* [**detail**]

**Context** tools>dump>router>ospf

**Description** This command displays dump retransmission list information for OSPF.

**Default** none

**Parameters** **neighbor** *ip-address* — Display neighbor information only for neighbor identified by the IP address.  
*detail* — Displays detailed information about the neighbor.  
**virtual-neighbor** *ip-address* — Displays information about the virtual neighbor identified by the IP address.  
**area-id** *area-id* — The OSPF area ID expressed in dotted decimal notation or as a 32-bit decimal integer.

## route-summary

**Syntax** **route-summary**

**Context** tools>dump>router>ospf

**Description** This command displays dump route summary information for OSPF.

**Default** none

## route-table

**Syntax** **route-table** *ip-prefix/mask* [**type**] [**detail**]

**Context** tools>dump>router>ospf

**Description** This command displays dump information about routes learned through OSPF.

**Default** none

**Parameters** **type** — Specify the type of route table to display information.  
**Values** intra-area, inter-area, external-1, external-2, nssa-1, nssa-2  
**detail** — Displays detailed information about learned routes.

## ospf3

<b>Syntax</b>	<b>ospf3</b>
<b>Context</b>	tools>dump>router
<b>Description</b>	This command enables the context to display tools information for OSPF3.
<b>Default</b>	none

## refresh-lsas

<b>Syntax</b>	<b>refresh-lsas [lsa-type] [area-id]</b>
<b>Context</b>	tools>perform>router>ospf tools>perform>router>ospf3
<b>Description</b>	This command refreshes LSAs for OSPF.
<b>Default</b>	none
<b>Parameters</b>	<b>lsa-type</b> — Specify the LSA type using allow keywords. <b>Values</b> router, network, summary, asbr, extern, nssa, opaque <b>area-id</b> — The OSPF area ID expressed in dotted decimal notation or as a 32-bit decimal integer. <b>Values</b> 0 — 4294967295

## run-manual-spf

<b>Syntax</b>	<b>run-manual-spf externals-only</b>
<b>Context</b>	tools>perform>router>ospf tools>perform>router>ospf3
<b>Description</b>	This command runs the Shortest Path First (SPF) algorithm.
<b>Default</b>	none
<b>Parameters</b>	<b>externals-only</b> — Specify the route preference for OSPF external routes.

## rsvp

<b>Syntax</b>	rsvp
<b>Context</b>	tools>dump>router
<b>Description</b>	This command enables the context to display RSVP information.

## Router Commands

**Default** none

### psb

**Syntax** **psb** [**endpoint** *endpoint-address*] [**sender** *sender-address*] [**tunnelid** *tunnel-id*] [**lspid** *lsp-id*]

**Context** tools>dump>router>rsvp

**Description** This command displays path state block (PSB) information for RSVP.  
When a PATH message arrives at an LSR, the LSR stores the label request in the local PSB for the LSP. If a label range is specified, the label allocation process must assign a label from that range.  
The PSB contains the IP address of the previous hop, the session, the sender, and the TSPEC. This information is used to route the corresponding RESV message back to LSR 1.

**Default** none

**Parameters** **endpoint** *endpoint-address* — Specifies the IP address of the last hop.

**sender** *sender-address* — Specifies the IP address of the sender.

**tunnelid** *tunnel-id* — Specifies the SDP ID.

**Values** 0 — 4294967295

**lspid** *lsp-id* — Specifies the label switched path that is signaled for this entry.

**Values** 1 — 65535

### rsb

**Syntax** **rsb** [**endpoint** *endpoint-address*] [**sender** *sender-address*] [**tunnelid** *tunnel-id*] [**lspid** *lsp-id*]

**Context** tools>dump>router>rsvp

**Description** This command displays RSVP Reservation State Block (RSB) information.

**Default** none

**Parameters** **endpoint** *endpoint-address* — Specifies the IP address of the last hop.

**sender** *sender-address* — Specifies the IP address of the sender.

**tunnelid** *tunnel-id* — Specifies the SDP ID.

**Values** 0 — 4294967295

**lspid** *lsp-id* — Specifies the label switched path that is signaled for this entry.

**Values** 1 — 65535

## tcsb

<b>Syntax</b>	<b>tcsb</b> [ <b>endpoint</b> <i>endpoint-address</i> ] [ <b>sender</b> <i>sender-address</i> ] [ <b>tunnelid</b> <i>tunnel-id</i> ] [ <b>lspid</b> <i>lsp-id</i> ]
<b>Context</b>	tools>dump>router>rsvp
<b>Description</b>	This command displays RSVP traffic control state block (TCSB) information.
<b>Default</b>	none
<b>Parameters</b>	<p><b>endpoint</b> <i>endpoint-address</i> — Specifies the IP address of the egress node for the tunnel supporting this session.</p> <p><b>sender</b> <i>sender-address</i> — Specifies the IP address of the sender node for the tunnel supporting this session. It is derived from the source address of the associated MPLS LSP definition.</p> <p><b>tunnelid</b> <i>tunnel-id</i> — Specifies the IP address of the ingress node of the tunnel supporting this RSVP session.</p> <p><b>Values</b>      0 — 4294967295</p> <p><b>lspid</b> <i>lsp-id</i> — Specifies the label switched path that is signaled for this entry.</p> <p><b>Values</b>      1 — 65535</p>

## static-route

<b>Syntax</b>	<b>static-route</b> <b>ldp-sync-status</b>
<b>Context</b>	tools>dump>router
<b>Description</b>	This command displays the sync status of LDP interfaces that static-route keeps track of.

---

## Performance Tools

### perform

**Syntax** perform

**Context** tools

**Description** This command enables the context to enable tools to perform specific tasks.

**Default** none

### cron

**Syntax** cron

**Context** tools>perform

**Description** This command enables the context to perform CRON (scheduling) control operations.

**Default** none

### action

**Syntax** action

**Context** tools>perform>cron

**Description** This command enables the context to stop the execution of a script started by CRON action. See the **stop** command.

### stop

**Syntax** stop [*action-name*] [**owner** *action-owner*] [**all**]

**Context** tools>perform>cron>action

**Description** This command stops execution of a script started by CRON action.

**Parameters** *action-name* — Specifies the action name.

**Values** Maximum 32 characters.

**owner** *action-owner* — Specifies the owner name.

**Default** TiMOS CLI

**all** — Specifies to stop all CRON scripts.

## tod

<b>Syntax</b>	<b>tod</b>
<b>Context</b>	tools>perform>cron
<b>Description</b>	This command enables the context for tools for controlling time-of-day actions.
<b>Default</b>	none

## re-evaluate

<b>Syntax</b>	<b>re-evaluate</b>
<b>Context</b>	tools>perform>cron>tod
<b>Description</b>	This command enables the context to re-evaluate the time-of-day state.
<b>Default</b>	none

## customer

<b>Syntax</b>	<b>customer</b> <i>customer-id</i> [ <b>site</b> <i>customer-site-name</i> ]
<b>Context</b>	tools>perform>cron>tod>re-eval
<b>Description</b>	This command re-evaluates the time-of-day state of a multi-service site.
<b>Parameters</b>	<i>customer-id</i> — Specify an existing customer ID. <b>Values</b> 1 — 2147483647 <i>site</i> <i>customer-site-name</i> — Specify an existing customer site name.

## filter

<b>Syntax</b>	<b>filter</b> <i>ip-filter</i> [ <i>filter-id</i> ] <b>filter</b> <i>ipv6-filter</i> [ <i>filter-id</i> ] <b>filter</b> <i>mac-filter</i> [ <i>filter-id</i> ]
<b>Context</b>	tools>perform>cron>tod>re-eval
<b>Description</b>	This command re-evaluates the time-of-day state of a filter entry.
<b>Parameters</b>	<i>filter-type</i> — Specify the filter type. <b>Values</b> ip-filter, mac-filter <i>filter-id</i> — Specify an existing filter ID. <b>Values</b> 1 — 65535

## service

**Syntax** `service id service-id [sap sap-id]`

**Context** `tools>perform>cron>tod>re-eval`

**Description** This command re-evaluates the time-of-day state of a SAP.

**Parameters** `r service-id` — Specify the an existing service ID.

**Values** 1 — 2147483647

`sap sap-id` — Specifies the physical port identifier portion of the SAP definition. See [Common CLI Command Descriptions on page 345](#) for CLI command syntax.

## tod-suite

**Syntax** `tod-suite tod-suite-name`

**Context** `tools>perform>cron>tod>re-eval`

**Description** This command re-evaluates the time-of-day state for the objects referring to a tod-suite.

**Parameters** `tod-suite-name` — Specify an existing TOD nfname.

## ldp-sync-exit

**Syntax** `[no] ldp-sync-exit`

**Context** `tools>perform>router>isis`  
`tools>perform>router>ospf`  
`tools>perform>router>ospf3`

**Description** This command restores the actual cost of an interface at any time. When this command is executed, IGP immediately advertises the actual value of the link cost for all interfaces which have the IGP-LDP synchronization enabled if the currently advertised cost is different.

## run-manual-spf

<b>Syntax</b>	<b>run-manual-spf</b>
<b>Context</b>	tools>perform>router>isis tools>perform>router>ospf
<b>Description</b>	This command runs the Shortest Path First (SPF) algorithm or OSPF or ISIS.
	tools>perform m>router>o spf3

## isis

Note : This command is not supported on 7210 SAS-M and 7210 SAS-T devices configured in Access uplink mode

<b>Syntax</b>	<b>isis</b>
<b>Context</b>	tools>perform>router
<b>Description</b>	This command enables the context to configure tools to perform certain ISIS tasks.

## mpls

Note : This command is not supported on 7210 SAS-M and 7210 SAS-T devices configured in Access uplink mode

<b>Syntax</b>	<b>mpls</b>
<b>Context</b>	tools>perform>router
<b>Description</b>	This command enables the context to perform specific MPLS tasks.
<b>Default</b>	none

## cspf

<b>Syntax</b>	<b>cspf to ip-addr</b> [ <b>from ip-addr</b> ] [ <b>bandwidth bandwidth</b> ] [ <b>include-bitmap bitmap</b> ] [ <b>exclude-bitmap bitmap</b> ] [ <b>hop-limit limit</b> ] [ <b>exclude-address excl-addr</b> [ <b>excl-addr...</b> (up to 8 max)]] [ <b>use-te-metric</b> ] [ <b>skip-interface interface-name</b> ] [ <b>ds-class-type class-type</b> ] [ <b>cspf-reqtype req-type</b> ]
<b>Context</b>	tools>perform>router>mpls
<b>Description</b>	This command computes a CSPF path with specified user constraints.
<b>Default</b>	none
<b>Parameters</b>	<b>to ip-addr</b> — Specify the destination IP address. <b>from ip-addr</b> — Specify the originating IP address.

## Performance Tools

**bandwidth** *bandwidth* — Specifies the amount of bandwidth in mega-bits per second (Mbps) to be reserved.

**Values** 1 - 100000 in Mbps

**include-bitmap** *bitmap* — Specifies to include a bit-map that specifies a list of admin groups that should be included during setup.

**Values** 0 - 4294967295 - accepted in decimal, hex(0x) or binary(0b)

**exclude-bitmap** *bitmap* — Specifies to exclude a bit-map that specifies a list of admin groups that should be included during setup.

**Values** 0 - 4294967295 - accepted in decimal, hex(0x) or binary(0b)

**hop-limit** *limit* — Specifies the total number of hops a detour LSP can take before merging back onto the main LSP path.

**Values** 1- 255

**exclude-address** *ip-addr* — Specifies an IP address to exclude from the operation.

**use-te-metric** — Specifies whether the TE metric would be used for the purpose of the LSP path computation by CSPF.

**skip-interface** *interface-name* — Specifies a local interface name, instead of the interface address, to be excluded from the CSPF computation.

## resignal

**Syntax** **resignal lsp** *lsp-name* **path** *path-name* **delay** *minutes*

**Context** tools>perform>router>mpls

**Description** Use this command to resignal a specific LSP path.

**Default** none

**Parameters** **lsp** *lsp-name* — Specifies the name that identifies the LSP. The LSP name can be up to 32 characters long and must be unique.

**path** *path-name* — Specifies the name for the LSP path up, to 32 characters in length.

**delay** *minutes* — Specifies the resignal delay in minutes.

**Values** 0 — 30

## trap-suppress

**Syntax** **trap-suppress** [*number-of-traps*] [*time-interval*]

**Context** tools>perform>router>mpls

**Description** This command modifies thresholds for trap suppression.

**Default** none

- Parameters** *number-of-traps* — Specify the number of traps in multiples of 100. An error messages is generated if an invalid value is entered.
- Values** 100 to 1000
- time-interval* — Specify the timer interval in seconds.
- Values** 1 — 300

## ospf

Note : This command is not supported on 7210 SAS-M and 7210 SAS-T devices configured in Access uplink mode

- Syntax** ospf
- Context** tools>perform>router
- Description** This command enables the context to perform specific OSPF tasks.
- Default** none

## ldp-sync-exit

- Syntax** [no] ldp-sync-exit
- Context** tools>perform>router>isis  
tools>perform>router>ospf
- Description** This command restores the actual cost of an interface at any time. When this command is executed, IGP immediately advertises the actual value of the link cost for all interfaces which have the IGP-LDP synchronization enabled if the currently advertised cost is different.

## service

- Syntax** services
- Context** tools>perform
- Description** This command enables the context to configure tools for services.

## id

- Syntax** id *service-id*
- Context** tools>perform>service
- Description** This command enables the context to configure tools for a specific service.

## Performance Tools

**Parameters** *service-id* — Specify an existing service ID.

**Values** 1 — 2147483647

### endpoint

**Syntax** **endpoint** *endpoint-name*

**Context** tools>perform>service>id

**Description** This command enables the context to configure tools for a specific VLL service endpoint.

**Parameters** *endpoint-name* — Specify an existing VLL service endpoint name.

### force-switchover

**Syntax** **force-switchover** *sdp-id:vc-id*  
**no force-switchover**

**Context** tools>perform>service>id

**Description** This command forces a switch of the active spoke SDP for the specified service.

**Parameters** *sdp-id:vc-id* — Specify an existing spoke SDP for the service.

#### Sample Output

```
A:Dut-B# tools perform service id 1 endpoint mcep-t1 force-switchover 221:1
*A:Dut-B# show service id 1 endpoint
=====
Service 1 endpoints
=====
Endpoint name           : mcep-t1
Description              : (Not Specified)
Revert time              : 0
Act Hold Delay           : 0
Ignore Standby Signaling : false
Suppress Standby Signaling : false
Block On Mesh Fail      : true
Multi-Chassis Endpoint  : 1
MC Endpoint Peer Addr   : 3.1.1.3
Psv Mode Active          : No
Tx Active                 : 221:1(forced)
Tx Active Up Time        : 0d 00:00:17
Revert Time Count Down   : N/A
Tx Active Change Count   : 6
Last Tx Active Change    : 02/14/2009 00:17:32
-----
Members
-----
Spoke-sdp: 221:1 Prec:1                               Oper Status: Up
Spoke-sdp: 231:1 Prec:2                               Oper Status: Up
=====
*A:Dut-B#
```

## eval-pw-template

- Syntax** **eval-pw-template**
- Context** tools>perform>service
- Description** This command re-evaluates the pseudowire template policy.
- Parameters** *policy-id* — Specifies the pseudowire template policy.

## eval-expired-fec

- Syntax** **eval-expired-fec** spoke-sdp-fec-id  
**eval-expired-fec** all
- Context** tools>perform>service>pw-routing
- Description** This command will reset the retry counter and retry timer for the specified spoke-SDP and attempt to establish the spoke-SDP again.

## spoke-sdp-fec-release

- Syntax** **spoke-sdp-fec-release** *global-id[:prefix[:ac-id]]*
- Context** tools>perform>service
- Description** This command clears the MS-PW bindings associated with a particular SAII or TAIID on an S-PE.
- Parameters** *global-id* — The Global ID of either the SAII or TAIID of the MS-PW to be released.  
**Values** [1..4294967295]
- prefix* — The prefix of either the SAII or TAIID of the MS-PW to be released.  
**Values** ipv4-formatted address: a.b.c.d | [1..4294967295]
- ac-id* — The AC-ID of either the SAII or TAIID of the MS-PW to be released.  
[1..4294967295]



# Common CLI Command Descriptions

---

## In This Chapter

This chapter provides CLI syntax and command descriptions for SAP and port commands.

Topics in this chapter include:

- [SAP Syntax on page 346](#)
- [Port Syntax on page 202](#)

## Common Service Commands

### sap

**Syntax** [no] **sap** *sap-id*

**Description** This command specifies the physical port identifier portion of the SAP definition.

**Parameters** *sap-id* — Specifies the physical port identifier portion of the SAP definition.

The *sap-id* can be configured in one of the following formats:

Type	Syntax	Example
port-id	<i>slot/mda/port[.channel]</i>	1/1/5
null	[ <i>port-id</i>   <i>lag-id</i> ]	<i>port-id</i> : 1/1/3 <i>lag-id</i> : lag-3
dot1q	[ <i>port-id</i>   <i>lag-id</i> ]:qtag1	<i>port-id</i> :qtag1: 1/1/3:100 <i>lag-id</i> :qtag1:lag-3:102
qinq	[ <i>port-id</i> / <i>lag-id</i> ]:qtag1.qtag2	<i>port-id</i> :qtag1.qtag2: 1/1/3:100.10 <i>lag-id</i> :qtag1.qtag2: lag-10:

### port

**Syntax** **port** *port-id*

**Description** This command specifies a port identifier.

**Parameters** *port-id* — The *port-id* can be configured in one of the following formats.

Values	port-id	slot/mda/port[.channel]	lag-id	lag-id	lag	keyword	id	1— 200

# Standards and Protocol Support



**NOTE:** The capabilities available when operating in access-uplink mode/L2 mode and network mode/MPLS mode are different. Correspondingly, not all the standards and protocols listed below are applicable to access-uplink mode and network mode.

## Standards Compliance

IEEE 802.1ab-REV/D3 Station and Media Access Control Connectivity Discovery  
IEEE 802.1D Bridging  
IEEE 802.1p/Q VLAN Tagging  
IEEE 802.1s Multiple Spanning Tree  
IEEE 802.1w Rapid Spanning Tree Protocol  
IEEE 802.1X Port Based Network Access Control  
IEEE 802.1ad Provider Bridges  
IEEE 802.1ah Provider Backbone Bridges (**Not Supported on 7210 SAS-R6 and 7210 SAS-Mxp**)  
IEEE 802.1ag Service Layer OAM  
IEEE 802.3ah Ethernet in the First Mile  
IEEE 802.3 10BaseT  
IEEE 802.3ad Link Aggregation  
IEEE 802.3ae 10Gbps Ethernet  
IEEE 802.3u 100BaseTX  
IEEE 802.3z 1000BaseSX/LX  
ITU-T Y.1731 OAM functions and mechanisms for Ethernet based networks  
draft-ietf-disman-alarm-mib-04.txt  
IANA-IFType-MIB  
IEEE8023-LAG-MIB  
ITU-T G.8032 Ethernet Ring Protection Switching (version 2)

## Protocol Support

### BGP

RFC 1397 BGP Default Route Advertisement  
RFC 1772 Application of BGP in the Internet  
RFC 1997 BGP Communities Attribute

RFC 2385 Protection of BGP Sessions via MD5  
RFC 2439 BGP Route Flap Dampening  
RFC 2547bis BGP/MPLS VPNs  
draft-ietf-idr-rfc2858bis-09.txt.  
RFC 2918 Route Refresh Capability for BGP-4  
RFC 3107 Carrying Label Information in BGP-4  
RFC 3392 Capabilities Advertisement with BGP-4  
RFC 4271 BGP-4 (previously RFC 1771)  
RFC 4360 BGP Extended Communities Attribute  
RFC 4364 BGP/MPLS IP Virtual Private Networks (VPNs) (previously RFC 2547bis BGP/MPLS VPNs)  
RFC 4760 Multi-protocol Extensions for BGP  
RFC 4893 BGP Support for Four-octet AS Number Space  
RFC 5291 Outbound Route Filtering  
RFC 5668 4-Octet AS Specific BGP Extended Community Capability for BGP-4  
draft-ietf-idr-add-paths, 04, Advertisement of Multiple Paths in BGP

### CIRCUIT EMULATION (7210 SAS-M Only)

RFC 4553 Structure-Agnostic Time Division Multiplexing (TDM) over Packet (SAToP)  
RFC 5086 Structure-Aware Time Division Multiplexed (TDM) Circuit Emulation Service over Packet Switched Network (CESoPSN)  
RFC 5287 Control Protocol Extensions for the Setup of Time-Division Multiplexing (TDM) Pseudowires in MPLS Networks

### DHCP

RFC 2131 Dynamic Host Configuration Protocol  
RFC 3046 DHCP Relay Agent Information Option (Option 82)

### DIFFERENTIATED SERVICES

RFC 2474 Definition of the DS Field the IPv4 and IPv6 Headers (Rev)  
RFC 2597 Assured Forwarding PHB Group (rev3260)  
RFC 2598 An Expedited Forwarding PHB  
RFC 2697 A Single Rate Three Color Marker  
RFC 2698 A Two Rate Three Color Marker  
RFC 4115 A Differentiated Service Two-Rate, Three-Color Marker with Efficient Handling of in-Profile Traffic

### IP Fast Reroute

**NOTE: On 7210 LDP FRR is supported.**

RFC 5286, Basic Specification for IP Fast Reroute: Loop-Free Alternates  
draft-ietf-rtgwg-lfa-manageability-08, Operational management of Loop Free Alternates

### IPv6 (Not supported on 7210 SAS-T and 7210 SAS-Mxp)

RFC 2460 Internet Protocol, Version 6 (IPv6) Specification  
RFC 2461 Neighbor Discovery for IPv6  
RFC 2462 IPv6 Stateless Address Auto configuration  
RFC 2463 Internet Control Message Protocol (ICMPv6) for the Internet Protocol Version 6 Specification

## Standards and Protocols

RFC 2464 Transmission of IPv6 Packets over Ethernet Networks  
RFC 2545 Use of BGP-4 Multiprotocol Extension for IPv6 Inter-Domain Routing  
RFC 2740 OSPF for IPv6  
RFC 3587 IPv6 Global Unicast Address Format  
RFC 4007 IPv6 Scoped Address Architecture  
RFC 4193 Unique Local IPv6 Unicast Addresses  
RFC 4291 IPv6 Addressing Architecture  
RFC 4552 Authentication/Confidentiality for OSPFv3  
RFC 4659 BGP-MPLS IP Virtual Private Network (VPN) Extension for IPv6 VPN  
RFC 5095 Deprecation of Type 0 Routing Headers in IPv6  
draft-ietf-isis-ipv6-05  
draft-ietf-isis-wg-multi-topology-xx.txt

### IS-IS

RFC 1142 OSI IS-IS Intra-domain Routing Protocol (ISO 10589)  
RFC 1195 Use of OSI IS-IS for routing in TCP/IP & dual environments  
RFC 2763 Dynamic Hostname Exchange for IS-IS  
RFC 2966 Domain-wide Prefix Distribution with Two-Level IS-IS  
RFC 2973 IS-IS Mesh Groups  
RFC 3373 Three-Way Handshake for Intermediate System to Intermediate System (IS-IS) Point-to-Point Adjacencies  
RFC 3567 Intermediate System to Intermediate System (ISIS) Cryptographic Authentication  
RFC 3719 Recommendations for Interoperable Networks using IS-IS  
RFC 3784 Intermediate System to Intermediate System (IS-IS) Extensions for Traffic Engineering (TE)  
RFC 3787 Recommendations for Interoperable IP Networks  
RFC 3847 Restart Signaling for IS-IS – GR helper  
RFC 4205 for Shared Risk Link Group (SRLG) TLV

### MPLS - General

RFC 3031 MPLS Architecture  
RFC 3032 MPLS Label Stack Encoding  
RFC 4379 Detecting Multi-Protocol Label Switched (MPLS) Data Plane Failures  
RFC 4182 Removing a Restriction on the use of MPLS Explicit NULL

### MPLS - LDP

RFC 5036 LDP Specification  
RFC 3037 LDP Applicability  
RFC 3478 Graceful Restart Mechanism for LDP — GR helper  
RFC 5283 LDP extension for Inter-Area LSP  
RFC 5443 LDP IGP Synchronization

### MPLS - RSVP-TE

RFC 2430 A Provider Architecture DiffServ & TE  
RFC 2702 Requirements for Traffic Engineering over MPLS  
RFC2747 RSVP Cryptographic Authentication  
RFC3097 RSVP Cryptographic Authentication  
RFC 3209 Extensions to RSVP for Tunnels  
RFC 4090 Fast reroute Extensions to RSVP-TE for LSP Tunnels  
RFC 5817 Graceful Shutdown in MPLS and GMPLS Traffic Engineering Networks  
RFC 2961 RSVP Refresh Overhead Reduction Extensions

### MPLS-TP (Transport Profile) [7210 SAS-T in network mode only, 7210 SAS-R6 and 7210 SAS-R12]

RFC 5586 MPLS Generic Associated Channel  
RFC 5921 A Framework for MPLS in Transport Networks  
RFC 5960 MPLS Transport Profile Data Plane Architecture  
RFC 6370 MPLS-TP Identifiers  
RFC 6378 MPLS-TP Linear Protection  
RFC 6428 Proactive Connectivity Verification, Continuity Check and Remote Defect indication for MPLS Transport Profile

RFC 6426 MPLS On-Demand Connectivity and Route Tracing  
RFC 6478 Pseudowire Status for Static Pseudowires  
draft-ietf-mpls-tp-ethernet-addressing-02  
MPLS-TP Next-Hop Ethernet Addressing

### Multicast

RFC 1112 Host Extensions for IP Multicasting (Snooping)  
RFC 2236 Internet Group Management Protocol, (Snooping)  
RFC 3376 Internet Group Management Protocol, Version 3 (Snooping) [Only in 7210 SAS-M and 7210 SAS-T access-uplink mode and supported with IPv4 Multicast in network mode]  
RFC 2362 Protocol Independent Multicast Sparse Mode (PIM-SM)  
RFC 4601 Protocol Independent Multicast - Sparse Mode (PIM-SM): Protocol Specification (Revised)  
RFC 4604 Using IGMPv3 and MLDv2 for Source-Specific Multicast (MLDv2 is not supported)  
RFC 4607 Source-Specific Multicast for IP  
RFC 4608 Source-Specific Protocol Independent Multicast in 232/8  
draft-ietf-pim-sm-bsr-06.txt

### NETWORK MANAGEMENT

ITU-T X.721: Information technology-OSI-Structure of Management Information  
ITU-T X.734: Information technology-OSI-Systems Management: Event Report Management Function  
M.3100/3120 Equipment and Connection Models  
TMF 509/613 Network Connectivity Model  
RFC 1157 SNMPv1  
RFC 1215 A Convention for Defining Traps for use with the SNMP  
RFC 1907 SNMPv2-MIB  
RFC 2011 IP-MIB  
RFC 2012 TCP-MIB  
RFC 2013 UDP-MIB  
RFC 2096 IP-FORWARD-MIB  
RFC 2138 RADIUS

## Standards and Protocols

RFC 2206 RSVP-MIB  
RFC 2571 SNMP-FRAMEWORKMIB  
RFC 2572 SNMP-MPD-MIB  
RFC 2573 SNMP-TARGET-&-NOTIFICATION-MIB  
RFC 2574 SNMP-USER-BASEDSMMIB  
RFC 2575 SNMP-VIEW-BASEDACM-MIB  
RFC 2576 SNMP-COMMUNITY-MIB  
RFC 2665 EtherLike-MIB  
RFC 2819 RMON-MIB  
RFC 2863 IF-MIB  
RFC 2864 INVERTED-STACK-MIB  
RFC 3014 NOTIFICATION-LOGMIB  
RFC 3164 Syslog  
RFC 3273 HCRMON-MI  
RFC 3411 An Architecture for Describing Simple Network Management Protocol (SNMP) Management Frameworks  
RFC 3412 - Message Processing and Dispatching for the Simple Network Management Protocol (SNMP)  
RFC 3413 - Simple Network Management Protocol (SNMP) Applications  
RFC 3414 - User-based Security Model (USM) for version 3 of the Simple Network Management Protocol (SNMPv3)  
RFC 3418 - SNMP MIB  
draft-ietf-mpls-lsr-mib-06.txt  
draft-ietf-mpls-te-mib-04.txt  
draft-ietf-mpls-ldp-mib-07.txt

### OSPF

RFC 1765 OSPF Database Overflow  
RFC 2328 OSPF Version 2  
RFC 2370 Opaque LSA Support  
RFC 3101 OSPF NSSA Option  
RFC 3137 OSPF Stub Router Advertisement  
RFC 3623 Graceful OSPF Restart – GR helper  
RFC 3630 Traffic Engineering (TE) Extensions to OSPF Version 2  
RFC 2740 OSPF for IPv6 (OSPFv3)  
draft-ietf-ospf-ospfv3-update-14.txt  
RFC 4203 Shared Risk Link Group (SRLG) sub-TLV

RFC 4577 OSPF as the Provider/ Customer Edge Protocol for BGP/ MPLS IP Virtual Private Networks (VPNs)

### PSEUDO-WIRE

RFC 3985 Pseudo Wire Emulation Edge-to-Edge (PWE3)  
RFC 4385 Pseudo Wire Emulation Edge-to-Edge (PWE3) Control Word for Use over an MPLS PSN  
RFC 3916 Requirements for Pseudo-Wire Emulation Edge-to-Edge (PWE3)  
RFC 4448 Encapsulation Methods for Transport of Ethernet over MPLS Networks (draft-ietf-pwe3-ethernet-encap-11.txt)  
RFC 4446 IANA Allocations for PWE3  
RFC 4447 Pseudowire Setup and Maintenance Using LDP (draft-ietf-pwe3-control-protocol-17.txt)  
RFC 5085, Pseudowire Virtual Circuit Connectivity Verification (VCCV): A Control Channel for Pseudowires  
RFC 5659 An Architecture for Multi-Segment Pseudowire Emulation Edge-to-Edge  
draft-ietf-l2vpn-vpws-iw-oam-02.txt, OAM Procedures for VPWS Interworking  
RFC6310, Pseudowire (PW) OAM Message Mapping  
RFC6073, Segmented Pseudowire (draft-ietf-pwe3-segmented-pw-18.txt)  
draft-ietf-pwe3-dynamic-ms-pw-14.txt, Dynamic Placement of Multi Segment Pseudo Wires  
draft-ietf-pwe3-redundancy-bit-06.txt, Pseudowire Preferential Forwarding Status bit definition  
draft-ietf-pwe3-redundancy-06.txt, Pseudowire (PW) Redundancy

### RADIUS

RFC 2865 Remote Authentication Dial In User Service  
RFC 2866 RADIUS Accounting

### SSH

draft-ietf-secsh-architecture.txt SSH Protocol Architecture

draft-ietf-secsh-userauth.txt SSH Authentication Protocol  
draft-ietf-secsh-transport.txt SSH Transport Layer Protocol  
draft-ietf-secsh-connection.txt SSH Connection Protocol  
draft-ietf-secsh-newmodes.txt SSH Transport Layer Encryption Modes

### TACACS+

draft-grant-tacacs-02.txt

### TCP/IP

RFC 768 UDP  
RFC 1350 The TFTP Protocol  
RFC 791 IP  
RFC 792 ICMP  
RFC 793 TCP  
RFC 826 ARP  
RFC 854 Telnet  
RFC 1519 CIDR  
RFC 1812 Requirements for IPv4 Routers  
RFC 2347 TFTP option Extension  
RFC 2328 TFTP Blocksize Option  
RFC 2349 TFTP Timeout Interval and Transfer Size option  
draft-ietf-bfd-mib-00.txt Bidirectional Forwarding Detection Management Information Base  
RFC 5880 Bidirectional Forwarding Detection  
RFC 5881 BFD IPv4 (Single Hop)  
RFC 5883 BFD for Multihop Paths

### Timing

ITU-T G.781 Telecommunication Standardization Section of ITU, Synchronization layer functions, issued 09/2008  
ITU-T G.813 Telecommunication Standardization Section of ITU, Timing characteristics of SDH equipment slave clocks (SEC), issued 03/2003.  
GR-1244-CORE Clocks for the Synchronized Network: Common Generic Criteria, Issue 3, May 2005  
ITU-T G.8261 Telecommunication Standardization Section of ITU, Timing and synchronization aspects in packet networks, issued 04/2008.

## Standards and Protocols

ITU-T G.8262 Telecommunication Standardization Section of ITU, Timing characteristics of synchronous Ethernet equipment slave clock (EEC), issued 08/2007.

ITU-T G.8264 Telecommunication Standardization Section of ITU, Distribution of timing information through packet networks, issued 10/2008.

IEEE Std 1588™-2008, IEEE Standard for a Precision Clock Synchronization Protocol for Networked Measurement and Control Systems.

### VPLS

RFC 4762 Virtual Private LAN Services Using LDP (previously draft-ietf-l2vpn-vpls-ldp-08.txt)

### VRRP

RFC 2787 Definitions of Managed Objects for the Virtual Router Redundancy Protocol

RFC 3768 Virtual Router Redundancy Protocol

### Proprietary MIBs

ALCATEL-IGMP-SNOOPING-MIB.mib

TIMETRA-CAPABILITY-7210-SAS-M-V5v0.mib (7210 SAS-M Only)

TIMETRA-CAPABILITY-7210-SAS-X-V5v0.mib (7210 SAS-X Only)

TIMETRA-CHASSIS-MIB.mib

TIMETRA-CLEAR-MIB.mib

TIMETRA-DOT3-OAM-MIB.mib

TIMETRA-FILTER-MIB.mib

TIMETRA-GLOBAL-MIB.mib

TIMETRA-IEEE8021-CFM-MIB.mib

TIMETRA-LAG-MIB.mib

TIMETRA-LOG-MIB.mib

TIMETRA-MIRROR-MIB.mib

TIMETRA-NTP-MIB.mib

TIMETRA-OAM-TEST-MIB.mib

TIMETRA-PORT-MIB.mib

TIMETRA-QOS-MIB.mib

TIMETRA-SAS-ALARM-INPUT-MIB.mib

TIMETRA-SAS-FILTER-MIB.mib

TIMETRA-SAS-IEEE8021-CFM-MIB.mib

TIMETRA-SAS-IEEE8021-PAE-MIB.mib

TIMETRA-SAS-GLOBAL-MIB.mib

TIMETRA-SAS-LOG-MIB.mib.mib

TIMETRA-SAS-MIRROR-MIB.mib

TIMETRA-SAS-MPOINT-MGMT-MIB.mib (Only for 7210 SAS-X)

TIMETRA-SAS-PORT-MIB.mib

TIMETRA-SAS-QOS-MIB.mib

TIMETRA-SAS-SDP-MIB.mib

TIMETRA-SAS-SYSTEM-MIB.mib

TIMETRA-SAS-SERV-MIB.mib

TIMETRA-SAS-VRTR-MIB.mib

TIMETRA-SCHEDULER-MIB.mib

TIMETRA-SECURITY-MIB.mib

TIMETRA-SERV-MIB.mib

TIMETRA-SYSTEM-MIB.mib

TIMETRA-TC-MIB.mib

TIMETRA-ISIS-MIB.mib

TIMETRA-ROUTE-POLICY-MIB.mib

TIMETRA-MPLS-MIB.mib

TIMETRA-RSVP-MIB.mib

TIMETRA-LDP-MIB.mib

TIMETRA-VRRP-MIB.mib

TIMETRA-VRTR-MIB.mib





# Index

## C

continuity check 125  
CPE ping 80

## E

Ethernet CFM 107

## L

linktrace 123  
loopback 122  
LSP diagnostics 75

## M

MAC ping 78  
MAC populate 81  
MAC purge 81  
MAC trace 79  
Mirror  
    overview 16  
        implementation 17  
        source and destination 18  
    configuring  
        basic 30  
        classification rules 31  
            IP filter 32  
            MAC filter 32  
            port 31  
            SAP 31  
        command reference 47  
        local mirror service 34  
        management tasks 40  
        overview 28  
        remote mirror service 36

## O

OAM 74  
    overview 74  
    configuring  
        command reference 161

## P

ping

VCCV 82

## S

SAA test parameters 146  
SDP diagnostics 76  
SDP ping 76  
service assurance agent 145, 148  
service diagnostics 77

## T

Tools 303

## V

VCCV ping 82  
VLL diagnostics 82  
VPLS MAC diagnostics 78

