



# **7750 SR OS OAM and Diagnostics Guide**

Software Version: 7750 SR OS 8.0  
February 2010  
Document Part Number: 93-0181-04-01



---

This document is protected by copyright. Except as specifically permitted herein, no portion of the provided information can be reproduced in any form, or by any means, without prior written permission from Alcatel-Lucent.  
Alcatel, Lucent, Alcatel-Lucent and the Alcatel-Lucent logo are trademarks of Alcatel-Lucent. All other trademarks are the property of their respective owners.  
The information presented is subject to change without notice.  
Alcatel-Lucent assumes no responsibility for inaccuracies contained herein.

Copyright 2010 Alcatel-Lucent. All rights reserved.

# Table of Contents

<b>Preface</b> .....	11
<b>Getting Started</b>	
Alcatel-Lucent 7750 SR-Series Services Configuration Process .....	15
<b>Mirror Services</b>	
Service Mirroring .....	18
Mirror Implementation .....	20
Mirror Source and Destinations .....	20
Mirroring Performance .....	22
Mirroring Configuration .....	23
ATM Mirroring .....	25
IP Mirroring .....	27
Remote IP Mirroring .....	27
Local IP Mirroring .....	28
Port-ID Enabled PPP Mirroring .....	28
Subscriber Mirroring .....	29
Lawful Intercept .....	30
Pseudowire Redundant Mirror Services .....	31
Redundant Mirror Source Notes .....	33
Configuration Process Overview .....	34
Configuration Notes .....	36
Configuring Service Mirroring with CLI .....	37
Mirror Configuration Overview .....	38
Defining Mirrored Traffic .....	38
Lawful Intercept Configuration Overview .....	40
Saving LI Data .....	40
Regulating LI Access .....	41
LI Logging .....	45
Basic Mirroring Configuration .....	46
Mirror Classification Rules .....	48
Common Configuration Tasks .....	51
Configuring a Local Mirror Service .....	53
Configuring SDPs .....	55
Configuring a Remote Mirror Service .....	57
Configuring an ATM Mirror Service .....	60
Configuring Lawful Intercept Parameters .....	61
Pseudowire Redundancy for Mirror Services Configuration Example .....	62
Service Management Tasks .....	64
Modifying a Local Mirrored Service .....	66
Deleting a Local Mirrored Service .....	67
Modifying a Remote Mirrored Service .....	68
Deleting a Remote Mirrored Service .....	70
Mirror Service Command Reference .....	71
Configuration Commands .....	75

## Table of Contents

### OAM and SAA

OAM Overview	122
LSP Diagnostics	122
LSP Ping for RSVP P2MP LSP (P2MP)	123
LSP Trace for RSVP P2MP LSP	125
SDP Diagnostics	129
SDP Ping	129
SDP MTU Path Discovery	129
Service Diagnostics	130
VPLS MAC Diagnostics	130
MAC Ping	131
MAC Trace	131
CPE Ping	132
MAC Populate	133
MAC Purge	133
VLL Diagnostics	134
VCCV Ping	134
Automated VCCV-Trace Capability for MS-Pseudowire	139
IGMP Snooping Diagnostics	142
MFIB Ping	142
ATM Diagnostics	143
End-to-End Testing of Paths in an LDP ECMP Network	144
LDP ECMP Tree Building	145
Periodic Path Exercising	146
Ethernet Connectivity Fault Management (ETH-CFM)	147
ETH-CFM Building Blocks	148
Loopback	153
Linktrace	154
Continuity Check (CC)	156
Alarm Indication Signal (ETH-AIS Y.1731)	158
Test (ETH-TST Y.1731)	158
One-Way Delay Measurement (ETH-1DM Y.1731)	158
Two-Way Delay Measurement (ETH-DMM Y.1731)	158
OAM Mapping	159
CFM Connectivity Fault Conditions	159
CFM Fault Propagation Methods	160
Epipe Services	162
Ipipe Services	163
VPLS Service	164
IES and VPRN Services	166
Pseudowire Switching	166
LLF and CFM Fault Propagation	166
802.3ah EFM OAM Mapping and Interaction with Service Manager	167
Service Assurance Agent Overview	168
SAA Application	168
Traceroute Implementation	168
NTP	169
Ethernet CFM	169
Writing SAA Results to Accounting Files	170

Continuous Testing .....	170
Configuring SAA Test Parameters .....	171
Configuring Trap Generation .....	173
Diagnostics Command Reference .....	175
Tools Command Reference .....	281
<b>Common CLI Command Descriptions</b>	
Common Service Commands .....	328
<b>Standards and Protocol Support</b> .....	333
<b>Index</b> .....	339

## Table of Contents

# List of Tables

## Getting Started

Table 1: Configuration Process .....15

## Mirror Services

Table 2: Mirror Source Port Requirements .....49



# List of Figures

## Mirror Services

Figure 1:	Service Mirroring	19
Figure 2:	Local Mirroring Example	23
Figure 3:	Remote Mirroring Example	24
Figure 4:	Example of an ATM Mirror Service	26
Figure 6:	State Engine for Redundant Service to a Redundant Mirror Service	31
Figure 7:	State Engine for Redundant Service to a Non-Redundant Mirror Service	32
Figure 8:	State Engine for a Non-Redundant Service to a Redundant Mirror Service	32
Figure 9:	Mirror Configuration and Implementation Flow	34
Figure 10:	Lawful Intercept Configuration and Implementation Flow	35
Figure 11:	Creating an LI Operator Account	43
Figure 12:	Local Mirrored Service Tasks	51
Figure 13:	Remote Mirrored Service Configuration Example	52
Figure 14:	Remote Mirrored Service Tasks	58
Figure 15:	State Engine for Redundant Service to a Redundant Mirror Service	62

## OAM and SAA

Figure 16:	Modifications to the Downstream Mapping TLV	126
Figure 17:	OAM Control Word Format	134
Figure 18:	VCCV TLV	135
Figure 19:	VCCV-Ping Application	136
Figure 20:	VCCV-Ping over a Multi-Segment Pseudowire	138
Figure 21:	Network Resilience Using LDP ECMP	144
Figure 22:	MEP and MIP	151
Figure 23:	MEP, MIP and MD Levels	152
Figure 24:	CFM Loopback	153
Figure 25:	CFM Linktrace	154
Figure 26:	CFM Continuity Check	156
Figure 27:	CFM CC Failure Scenario	156



## About This Guide

This guide describes service mirroring and Operations, Administration and Management (OAM) and diagnostic tools provided by the 7750 SR OS and presents examples to configure and implement various tests.

This document is organized into functional chapters and provides concepts and descriptions of the implementation flow, as well as Command Line Interface (CLI) syntax and command usage.

---

## Audience

This manual is intended for network administrators who are responsible for configuring the 7750 SR routers. It is assumed that the network administrators have an understanding of networking principles and configurations. Protocols, standards, and services described in this manual include the following:

- CLI concepts
  - Subscriber services
  - Service mirroring
  - Operation, Administration and Maintenance (OAM) operations
- 

## List of Technical Publications

The 7750 SR documentation set is composed of the following books:

- 7750 SR OS Basic System Configuration Guide  
This guide describes basic system configurations and operations.
- 7750 SR OS System Management Guide  
This guide describes system security and access configurations as well as event logging and accounting logs.

- **7750 SR OS Interface Configuration Guide**  
This guide describes card, Media Dependent Adapter (MDA), and port provisioning.
- **7750 SR OS Router Configuration Guide**  
This guide describes logical IP routing interfaces and associated attributes such as an IP address, port, link aggregation group (LAG) as well as IP and MAC-based filtering, VRRP, and Cflowd.
- **7750 SR OS Routing Protocols Guide**  
This guide provides an overview of routing concepts and provides configuration examples for RIP, OSPF, IS-IS, Multicast, BGP, and route policies.
- **7750 SR OS MPLS Guide**  
This guide describes how to configure Multiprotocol Label Switching (MPLS) and Label Distribution Protocol (LDP).
- **7750 SR OS Services Guide**  
This guide describes how to configure service parameters such as service distribution points (SDPs), customer information, and user services.
- **7750 SR OS OAM and Diagnostic Guide**  
This guide describes how to configure features such as service mirroring and Operations, Administration and Management (OAM) tools.
- **7750 SR OS Triple Play Guide**  
This guide describes Triple Play services and support provided by the 7750 SR and presents examples to configure and implement various protocols and services.
- **7750 SR Quality of Service Guide**  
This guide describes how to configure Quality of Service (QoS) policy management.
- **OS Multi-Service ISA Guide**  
This guide describes services provided by integrated service adapters such as Application Assurance, IPSec, ad insertion (ADI) and Network Address Translation (NAT).

## Technical Support

If you purchased a service agreement for your 7750 SR router and related products from a distributor or authorized reseller, contact the technical support staff for that distributor or reseller for assistance. If you purchased an Alcatel-Lucent service agreement, contact your welcome center.

Web: [http://www1.alcatel-lucent.com/comps/pages/carrier\\_support.jhtml](http://www1.alcatel-lucent.com/comps/pages/carrier_support.jhtml)



# Getting Started

---

## In This Chapter

This book provides process flow information to configure service mirroring and Operations, Administration and Management (OAM) tools.

---

## Alcatel-Lucent 7750 SR-Series Services Configuration Process

[Table 1](#) lists the tasks necessary to configure mirroring, lawful intercept, and perform tools monitoring functions.

This guide is presented in an overall logical configuration flow. Each section describes a software area and provides CLI syntax and command usage to configure parameters for a functional area.

**Table 1: Configuration Process**

Area	Task	Chapter
Diagnostics/ Service verification	Mirroring	<a href="#">Mirror Services on page 17</a>
	Lawful Intercept	<a href="#">Lawful Intercept on page 30</a>
	OAM	<a href="#">OAM and SAA on page 121</a>
Reference	List of IEEE, IETF, and other proprietary entities.	<a href="#">Standards and Protocol Support on page 333</a>



# Mirror Services

---

## In This Chapter

This chapter provides information to configure mirroring.

Topics in this chapter include:

- [Service Mirroring on page 18](#)
  - [Mirror Implementation on page 20](#)
    - [Mirror Source and Destinations on page 20](#)
      - [Local and Remote Mirroring on page 21](#)
      - [Slicing on page 21](#)
    - [Mirroring Performance on page 22](#)
  - [Configuration Process Overview on page 34](#)
- [Lawful Intercept on page 30](#)
- [Pseudowire Redundant Mirror Services on page 31](#)
- [Configuration Notes on page 36](#)
- [Configuring Service Mirroring with CLI on page 37](#)
- [Common Configuration Tasks on page 51](#)
- [Service Management Tasks on page 64](#)

## Service Mirroring

When troubleshooting complex operational problems, customer packets can be examined as they traverse the network. Alcatel-Lucent's service mirroring provides the capability to mirror customer packets to allow for trouble shooting and offline analysis. One way to accomplish this is with an overlay of network analyzers established at multiple PoPs, together with skilled technicians to operate them to decode the data provided. This method of traffic mirroring often requires setting up complex filters in multiple switches and/or routers. These, at best, are only able to mirror from one port to another on the same device.

Alcatel-Lucent's service mirroring extends and integrates these capabilities into the network and provides significant operational benefits. Each 7750 SR can mirror packets from a specific service to any destination point in the network, regardless of interface type or speed.

This capability also extends beyond troubleshooting services. Telephone companies have the ability to obtain itemized calling records and wire-taps where legally required by investigating authorities. The process can be very complex and costly to carry out on data networks. Service Mirroring greatly simplifies these tasks, as well as reduces costs through centralization of analysis tools and skilled technicians.

Alcatel-Lucent's 7750 SR routers support service-based mirroring. While some Layer 3 switches and routers can mirror on a per-port basis within the device, Alcatel-Lucent 7750 SR routers can mirror on an n-to-1 unidirectional service basis and re-encapsulate the mirrored data for transport through the core network to another location, using either IP or MPLS tunneling as required (Figure 1).

Original packets are forwarded while a copy is sent out the mirrored port to the mirroring (destination) port. Service mirroring allows an operator to see the actual traffic on a customer's service with a sniffer sitting in a central location. In many cases, this reduces the need for a separate, costly overlay sniffer network.

The mirrored frame size that is to be transmitted to the mirror destination can be explicitly configured by using slicing features. This enables mirroring only the parts needed for analysis. For example, only the headers can be copied for analysis, protecting the integrity and security of customer data, or conversely, copying the full packet, including customer data.

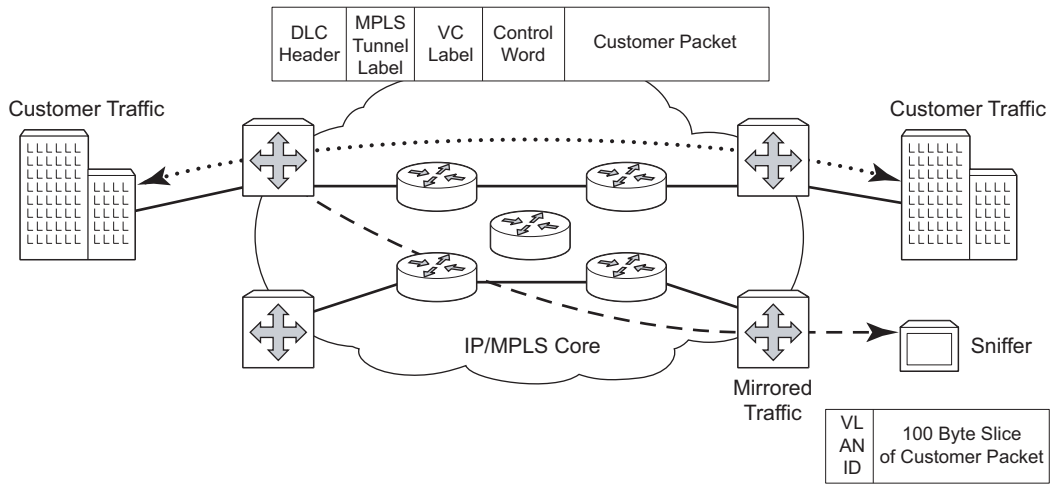

OSSG025

Figure 1: Service Mirroring

## Mirror Implementation

Mirroring can be implemented on ingress service access points (SAPs) or ingress network interfaces. The Flexible Fast Path processing complexes preserve the ingress packet throughout the forwarding and mirroring process, making incremental packet changes on a separate copy.

Alcatel-Lucent's implementation of packet mirroring is based on the following assumptions:

- Ingress and egress packets are mirrored as they appear on the wire. This is important for troubleshooting encapsulation and protocol issues.
  - When mirroring at ingress, the Flexible Fast Path network processor array (NPA) sends an exact copy of the original ingress packet to the mirror destination while normal forwarding proceeds on the original packet.
  - When mirroring is at egress, the system performs normal packet handling on the egress packet, encapsulating it for the destination interface. A copy of the forwarded packet (as seen on the wire) is forwarded to the mirror destination.
- Mirroring must support tunnel destinations.
  - Remote destinations are reached by encapsulating the ingress or egress packet within an SDP, like the traffic for distributed VPN connectivity services. At the remote destination, the tunnel encapsulation is removed and the packet is forwarded out a local SAP.

---

## Mirror Source and Destinations

Mirror sources and destinations have the following characteristics:

- They can be on the same 7750 SR router (local) or on two different routers (remote).
- Mirror destinations can terminate on egress virtual ports which allows multiple mirror destinations to send to the same packet decode device, delimited by IEEE 802.1Q (referred to as Dot1q) tags. This is helpful when troubleshooting a multi-port issue within the network.

When multiple mirror destinations terminate on the same egress port, the individual dot1q tags can provide a DTE/DCE separation between the mirror sources.
- Packets ingressing a port can have a mirror destination separate from packets egressing another or the same port (the ports can be on separate nodes).
- A total of 255 mirror destinations are supported (local and/or remote), per chassis.

## Local and Remote Mirroring

Mirrored frames can be copied and sent to a specific local destination or service on the 7750 SR router (local mirroring) or copies can be encapsulated and sent to a different 7750 SR router (remote mirroring). This functionality allows network operators to centralize not only network analyzer (sniffer) resources, but also the technical staff who operate them.

The 7750 SR allows multiple concurrent mirroring sessions so traffic from more than one ingress mirror source can be mirrored to the same or different egress mirror destinations.

Remote mirroring uses a service distribution path (SDP) which acts as a logical way of directing traffic from one 7750 SR router to another through a uni-directional (one-way) service tunnel. The SDP terminates at the far-end 7750 SR which directs packets to the correct destination on that device.

The SDP configuration from the mirrored device to a far-end router requires a return path SDP from the far-end router back to the mirrored router. Each device must have an SDP defined for every remote router to which it wants to provide mirroring services. SDPs must be created first, before services can be configured.

---

## Slicing

A further service mirroring refinement is “slicing” which copies a specified packet size of each frame. This is useful to monitor network usage without having to copy the actual data. Slicing enables mirroring larger frames than the destination packet decode equipment can handle. It also allows conservation of mirroring resources by limiting the size of the stream of packet through the 7750 SR and the core network.

When a mirror **slice-size** is defined, a threshold that truncates a mirrored frame to a specific size is created. For example, if the value of 256 bytes is defined, up to the first 256 bytes of the frame are transmitted to the mirror destination. The original frame is not affected by the truncation. Mirrored frames, most likely, will grow larger as encapsulations are added when packets are transmitted through the network core or out the mirror destination SAP to the packet/protocol decode equipment. Note that slice-size is not supported by CEM encap-types or IP-mirroring.

The transmission of a sliced or non-sliced frame is also dependent on the mirror destination SDP path MTU and/or the mirror destination SAP physical MTU. Packets that require a larger MTU than the mirroring destination supports are discarded if the defined slice size does not truncate the packet to an acceptable size.

## Mirroring Performance

Replication of mirrored packets can, typically, affect performance and should be used carefully. Alcatel-Lucent 7750 SR routers minimize the impact of mirroring on performance by taking advantage of its distributed Flexible Fast Path technology. Flexible Fast Path forwarding allows efficient mirror service scaling and, at the same time, allows a large amount of data to be mirrored with minimal performance impact. When a mirror destination is configured, the packet slice option can truncate mirrored packets to the destination, which minimizes replication and tunneling overhead. The mirroring architecture also supports mirror rate limiting both at the ingress and egress Flexible Fast Path NPA. This rate limiting is accomplished through a shaping queue and is set according to the maximum amount of mirroring desired.

Mirroring can be performed based on the following criteria:

- Port
- SAP
- MAC filter
- IP filter
- Ingress label
- Subscriber

## Mirroring Configuration

Configuring mirroring is similar to creating a uni-direction service. Mirroring requires the configuration of:

- Mirror source — The traffic on a specific point(s) to mirror.
- Mirror destination — The location to send the mirrored traffic, where the sniffer will be located.

Figure 2 depicts a local mirror service configured on ALA-A.

- Port 2/1/2 is specified as the source. Mirrored traffic ingress and egressing this port will be sent to port 2/1/3.
- SAP 2/1/3 is specified as the destination. The sniffer is physically connected to this port. Mirrored traffic ingress and egressing port 2/1/2 is sent here. SAP, encapsulation requirements, packet slicing, and mirror classification parameters are configured. SDPs are not used in local mirroring.

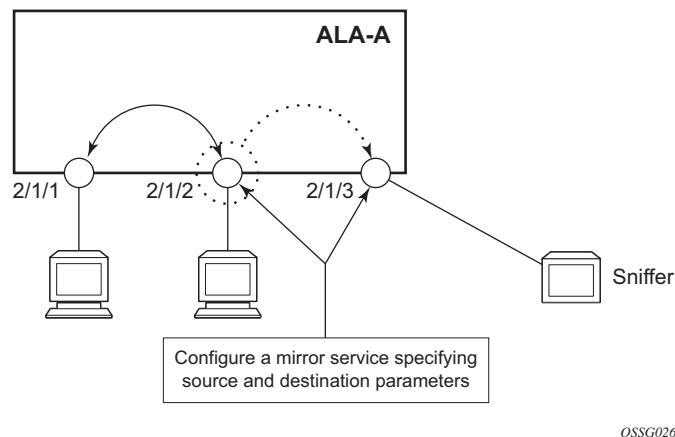

**Figure 2: Local Mirroring Example**

Figure 3 depicts a remote mirror service configured as ALA B as the mirror source and ALA A as the mirror destination. Mirrored traffic ingress and egressing port 5/2/1 (the source) on ALA B is handled the following ways:

- Port 5/2/1 is specified as the mirror source port. Parameters are defined to select specific traffic ingress and egressing this port.

## Mirror Implementation

Destination parameters are defined to specify where the mirrored traffic will be sent. In this case, mirrored traffic will be sent to a SAP configured as part of the mirror service on port 3/1/3 on ALA A (the mirror destination).

ALA A decodes the service ID and sends the traffic out of port 3/1/3. The sniffer is physically connected to this port (3/1/3). SAP, encapsulation requirements, packet slicing, and mirror classification parameters are configured in the destination parameters.

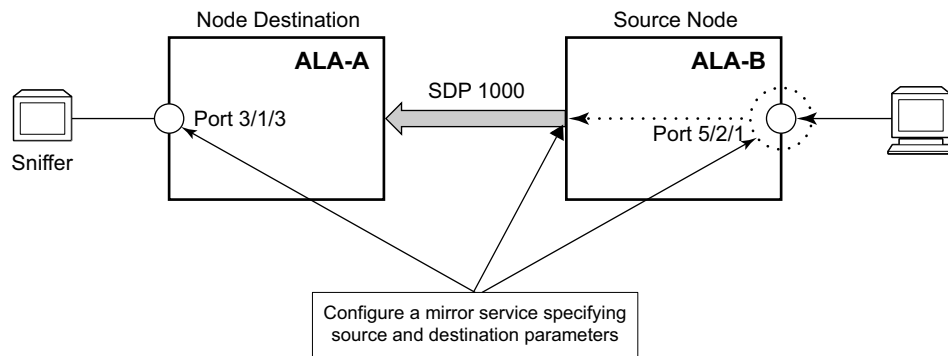

O5SG027

**Figure 3: Remote Mirroring Example**

## ATM Mirroring

ATM mirror functionality allows 7750 SR users to mirror AAL5 packets from a source ATM SAP to a destination ATM SAP connected locally or remotely. This functionality can be used to monitor the ATM traffic on a particular ATM SAP. In both the local and remote scenarios the source and destination SAPs must be of ATM SAP type.

All ingress and egress AAL5 traffic at the source ATM SAP is duplicated and sent toward the destination ATM SAP. Mirroring the ingress traffic only, egress traffic only, or both, can be configured. ATM OAM traffic is not mirrored toward the destination ATM SAP.

IP filters used as a mirror source are supported on ATM SAPs based on the IP filter applicability for different services.

ATM mirroring is applicable to the following services using an ATM SAP:

- Layer 3: IES and VPRN
- Layer 2: Apipe (sdu-type only), Ipipe, Epipe, VPLS

ATM mirroring on an ATM SAP extends the service mirroring feature to include mirror sources with SAP type of ATM. Mirroring is supported on the following services:

- IES
- VPRN
- VPLS
- Epipe
- Ipipe
- Apipe VLL service with the AAL5 SDU mode (atm-sdu spoke-sdp type)

Characteristics include:

- Supported only ATM MDAs and on the Any Service Any Port (ASAP) MDA.
- Mirror destinations for ATM mirroring must be ATM SAPs and cannot be part of an APS group, an IMA bundle, or an IMA Bundle Protection Group (BPGRP).
- A mirror source can be an ATM SAP component of an IMA bundle but cannot be part of an IMA BPGRP.
- ATM SAPs of an Apipe service with N:1 cell mode (atm-vcc, atm-vpc, and atm-cell spoke-sdp types) cannot be ATM mirror sources.

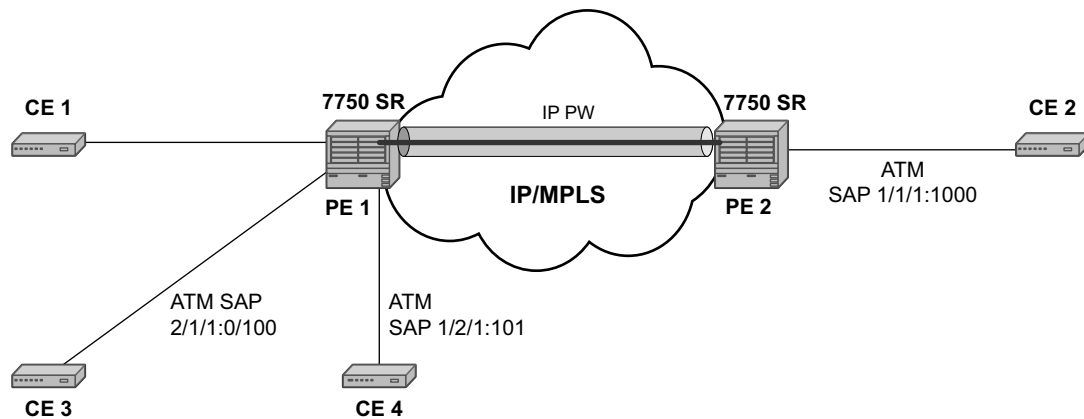

Fig 21

**Figure 4: Example of an ATM Mirror Service**

In [Figure 4](#), CE 3 is connected to PE1 on ATM SAP 2/1/1:0/100 as part of an IES service. The traffic on ATM SAP 2/1/1:0/100 is mirrored locally to CE4 device through ATM SAP 1/2/1:1/101. In this scenario, all AAL5 packets arriving at SAP 2/1/1:0/100 are duplicated and send towards ATM SAP 1/2/1:1/101.

In the case where the destination ATM SAP is on a remote node PE2, then the AAL5 traffic arriving at ATM SAP 2/1/1:0/100 is duplicated and sent across the IP/MPLS network to PE2. At PE2 the traffic is forwarded to ATM SAP 1/1/1:0/1000 towards the ATM traffic monitoring device.

## IP Mirroring

The IP mirroring capability allows a mirror to be created with a parameter that specifies that only the IP packet is mirrored without the original ATM/FR/POS/Ethernet DLC header. This results in the mirrored IP packet becoming media agnostic on the mirror service egress.

This option is configurable on SAP mirrors for IES, VPRN and VPLS services, Ipipe services, and subscriber mirrors. It is not supported on VLL services such as Apipe, Epipe, Fpipe, and on ports.

## Remote IP Mirroring

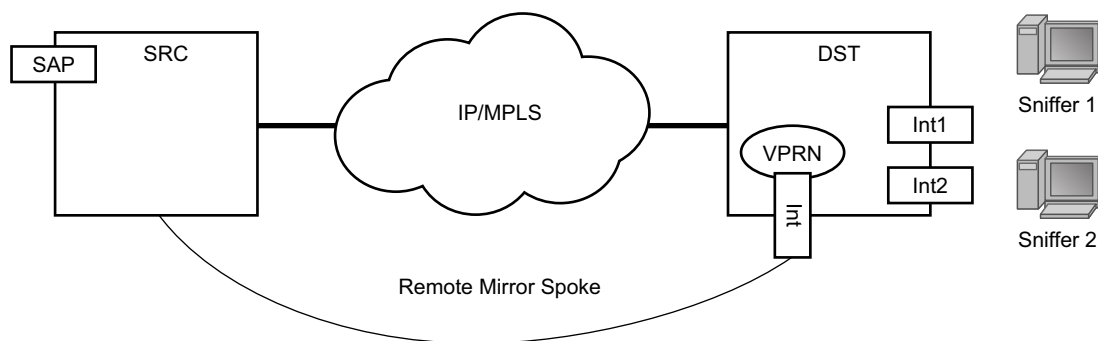

Fig\_17

**Figure 5: Remote IP Mirroring**

With remote IP mirroring, the mirror destination configuration can allow IP packets to be mirrored from a source router (Figure 5). The packets will be delivered to the destination in a spoke-terminated interface created in a VPRN service. IES interfaces are not supported. The interface can be configured with policy-based routing filters to allow sniffer selection based on incoming mirrored destination IP addresses. The interface cannot send traffic out as it is a destination only feature. Packets arriving at the interface will be routed based on the routing information within the VPRN. Policy-based routing should always be used unless only a sniffer is connected to the VPRN.

## Local IP Mirroring

Local mirroring is similar to remote mirroring but the source and destination of the mirror exist in the same Local IP mirroring node. The configuration must include the source address and destination MAC addresses for the packets going to the sniffer. The destination SAP must be Ethernet.

---

## Port-ID Enabled PPP Mirroring

Operators that use mirroring for statistics collection make use of VLANs or DLCIs for customer separation. Since PPP offers no such separation, the maximum number of PPP circuits may be identified (one per destination). This feature provides a proprietary mechanism to allow a single mirror to be used.

Port-ID enabled PPP mirroring includes the system's port ID in the mirrored packet. An operator using this flag in a PPP mirror will be able to identify the end customer circuit by finding the system's port ID (which is optionally made persistent) and correlating it to the port-id in the mirrored packet.

This mirroring does not change the priority of the mirror order (port/sap/sub/filter). Lawful intercept mirrors can use the flag and their priority is also maintained.

Since the inclusion of the port ID flag is placed on the mirror destination, all mirrored packets of all sources will include the port ID. For remote mirroring, the mirror destination service at the source node must be configured with this flag.

Note the following restrictions:

- This flag can only be used with a PPP mirror destination.
- This flag is mutually exclusive with a remote-source.
- This flag cannot be enabled on a an IP mirror type.

## Subscriber Mirroring

This section describes mirroring based on a subscriber match. Enhanced subscriber management provides the mechanism to associate subscriber hosts with queuing and filtering resources in a shared SAP environment. Mirroring used in subscriber aggregation networks for lawful intercept and debugging is required. With this feature, the mirroring capability allows the match criteria to include a subscriber-id.

Subscriber mirroring provides the ability to create a mirror source with subscriber information as match criteria. Specific subscriber packets can be mirrored mirror when using ESM with a shared SAP without prior knowledge of their IP or MAC addresses and without concern that they may change. The subscriber mirroring decision is more specific than a SAP. If a SAP (or port) is placed in a mirror and a subscriber host of which a mirror was configured is mirrored on that SAP packets matching the subscriber host will be mirrored to the subscriber mirror destination.

The mirroring configuration can be limited to specific forwarding classes used by the subscriber. When a forwarding class (FC) map is placed on the mirror only packets that match the specified FCs are mirrored. A subscriber can be referenced in maximum 2 different mirror-destinations: 1 for ingress and 1 for egress.

## Lawful Intercept

Lawful Intercept (LI) describes a process to intercept telecommunications by which law enforcement authorities can un-obtrusively monitor voice and data communications to combat crime and terrorism with higher security standards of lawful intercept capabilities in accordance with local law and after following due process and receiving proper authorization from competent authorities. The interception capabilities are sought by various telecommunications providers.

As lawful interception is subject to national regulation, requirements vary from one country to another. Alcatel-Lucent's implementation satisfies most national standard's requirements. LI capability is configurable for all Alcatel-Lucent service types.

LI mirroring is configured by an operator that has LI permission. LI mirroring is hidden from anyone who does not have the right permission.

## Pseudowire Redundant Mirror Services

This section describes the implementation and configuration of redundant Mirror /Lawful Intercept services using redundant pseudowires.

Regardless of the protection mechanism (MC-LAG, STP or APS) the source switch will only transmit on the active link and not simultaneously on the standby link. As a result when configuring a redundant mirror / LI service or a mirror service where the customer has a redundant service but the mirror / LI service is not redundant the mirror source must be configured on both (A and B) PE nodes. In either case the PE with a mirror source will establish a pseudo wire to each eligible PE where the mirror / LI service terminates.

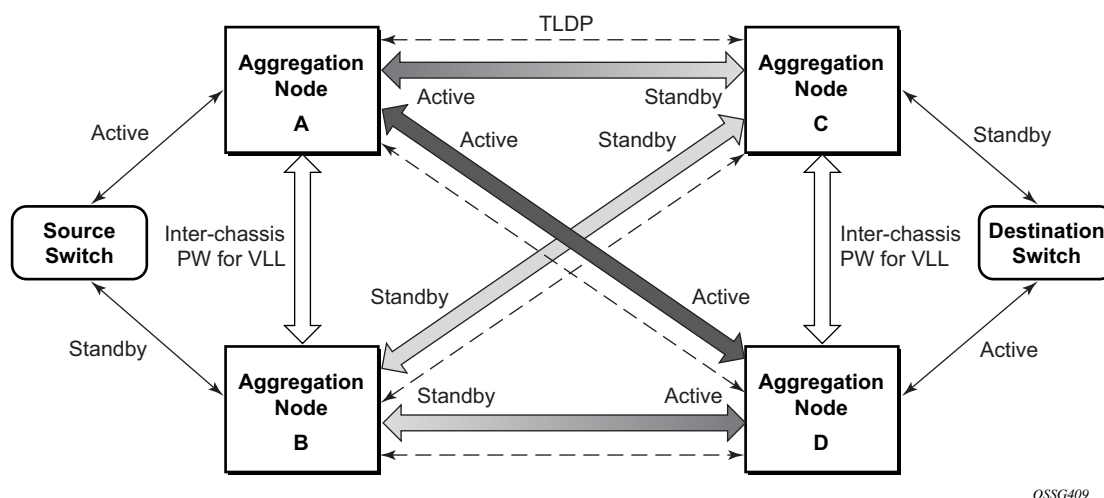

**Figure 6: State Engine for Redundant Service to a Redundant Mirror Service**

It is important to note that in order to provide protection in case the active SDP between node A and D fails and the need to limit the number of lost data for lawful intercept the ICB between node A and B must be supported. As a result when the SDP connecting nodes A and D fails the data on its way from the source switch to node A and the data in node A must be directed by the ICB to node B and from there to node D.

This functionality is already supported in when providing pseudo wire redundancy for VLLs and must be extended to mirror / LI service redundancy.

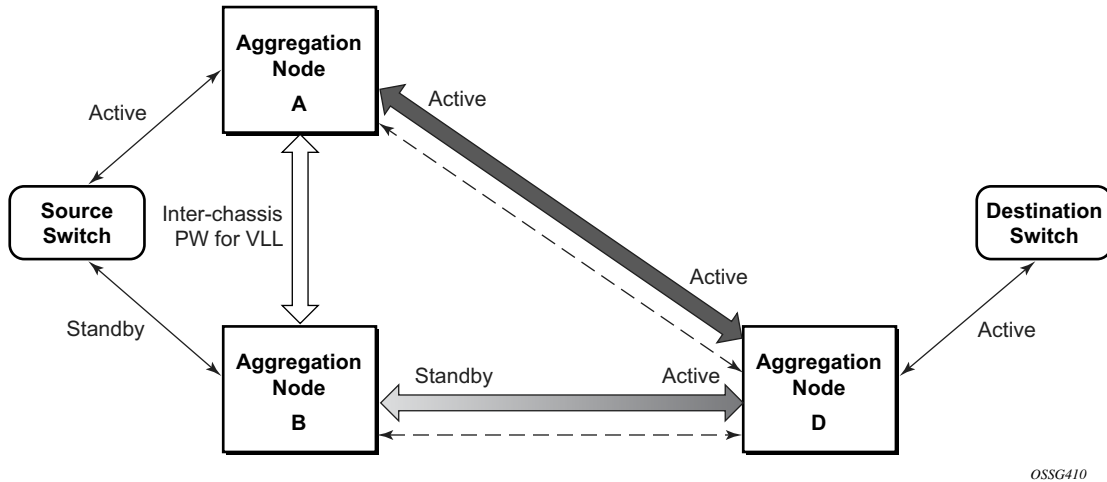

**Figure 7: State Engine for Redundant Service to a Non-Redundant Mirror Service**

The notable difference with scenarios standard pseudo wire redundancy scenarios is that provided the customer service is redundant on nodes A and B (Figure 6 and Figure 7) both aggregation node A and Aggregation node B maintain an active Pseudo wire to Node D who in turn has an active link to the destination switch. If in the sample in Figure 6, the link between D and the destination switch is disconnected then both aggregation A and B must switch to use pseudo wire connection to Node C.

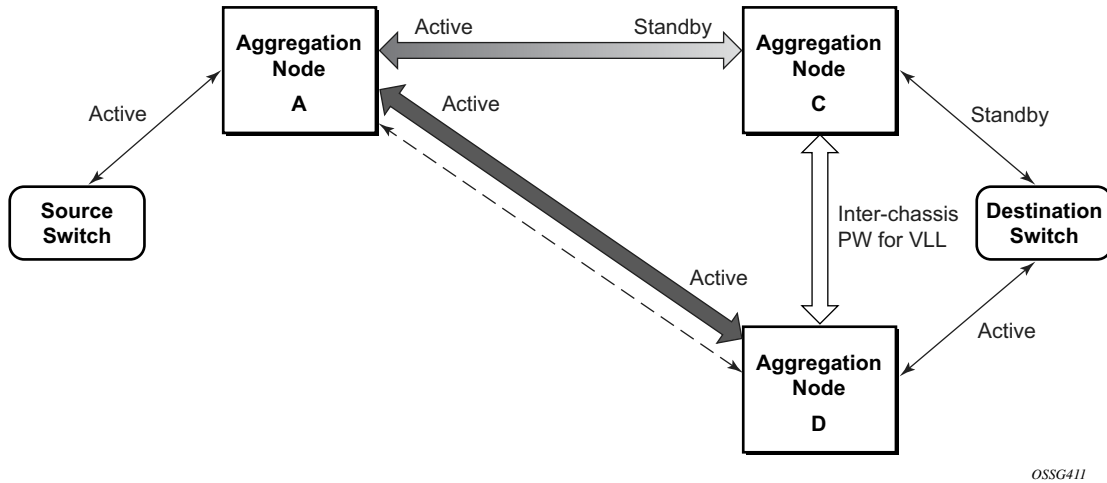

**Figure 8: State Engine for a Non-Redundant Service to a Redundant Mirror Service**

In the case where a non redundant service is being mirrored to a redundant mirror service (Figure 8) the source aggregation node (A) can only maintain a pseudo wire to the active destination aggregation node (D). Should the link between aggregation node D and the destination switch fail then the pseudo wire must switch to the new active aggregation node (C).

---

## Redundant Mirror Source Notes

A redundant remote mirror service destination is not supported for IP Mirrors (a set of remote IP mirror destinations). The remote destination of an IP mirror is a VPRN instance, and an “endpoint” cannot be configured in a VPRN service.

A redundant mirror source is supported for IP mirrors, but the remote destination must be a single node (a set of mirror source nodes, each with a mirror destination that points to the same destination node). In this case the destination node would have a VPRN instance with multiple ip-mirror-interfaces.

Multi Chassis APS (MC-APS) groups can not be used as the SAP for a redundant remote mirror destination service. APS can not be used to connect the remote mirror destination SR nodes to a destination switch.

Multi Chassis APS (MC-APS) groups can be used as the SAP for a redundant mirror service source. APS can be used to redundantly connect the source of the mirrored traffic to the SR nodes that are behaving as the mirror-sources.

## Configuration Process Overview

Figure 9 displays the process to provision basic mirroring parameters.

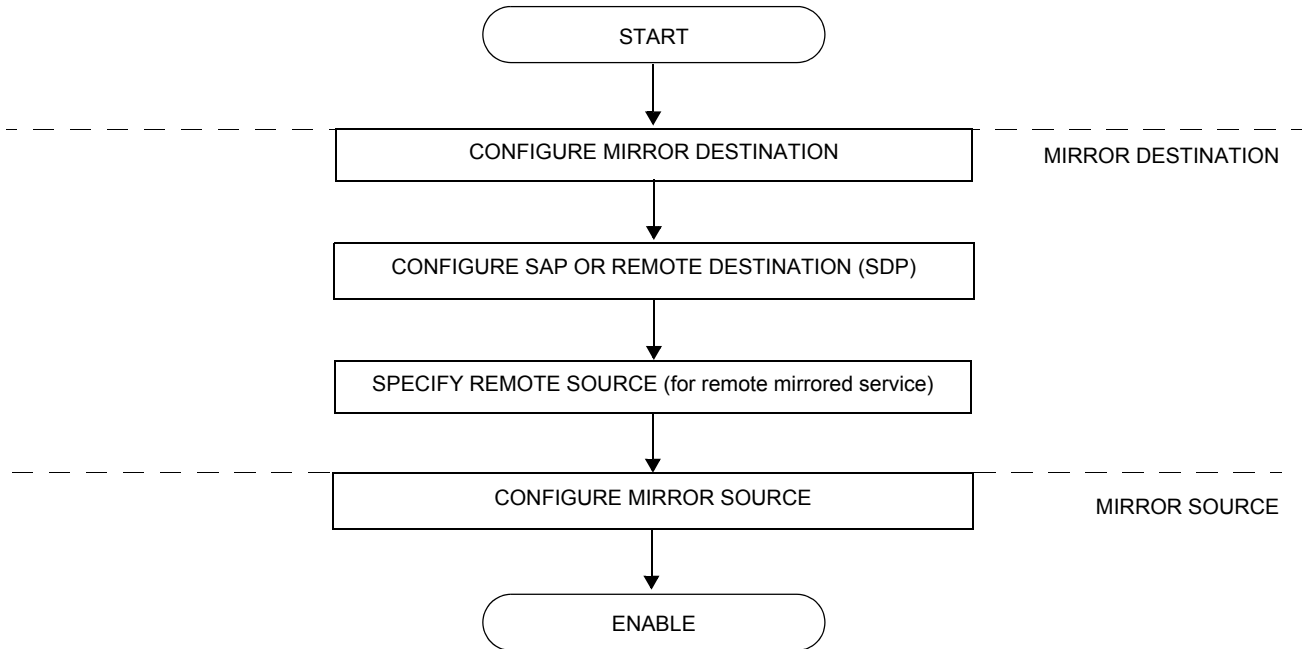
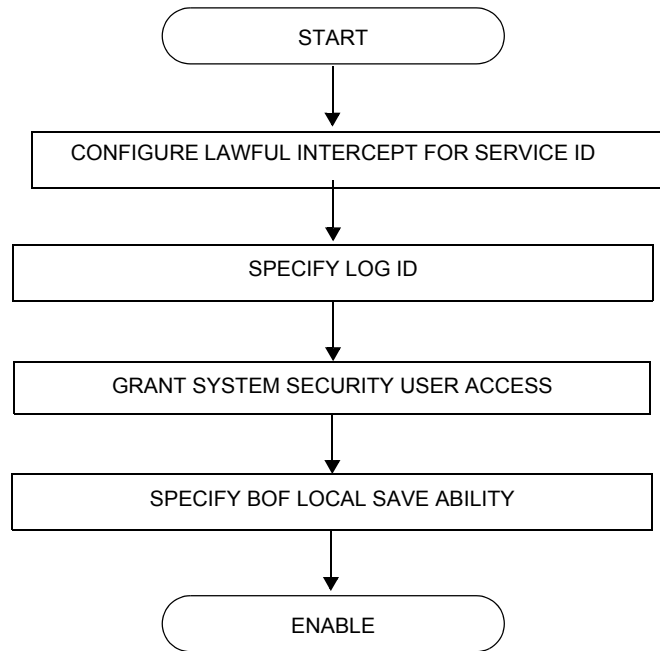

Figure 9: Mirror Configuration and Implementation Flow

Figure 10 displays the process to provision lawful intercept parameters.



**Figure 10: Lawful Intercept Configuration and Implementation Flow**

## Configuration Notes

This section describes mirroring configuration caveats.

- Up to 255 mirroring service IDs may be created within a single system.
- A mirrored source can only have one destination.
- The destination mirroring service IDs and service parameters are persistent between router (re)boots and are included in the configuration saves.

The source packet mirroring enabling criteria defined in `debug mirror mirror-source` commands are not preserved in configuration saves.

- Physical layer problems such as collisions, jabbers, etc., are not mirrored. Typically, only complete packets are mirrored.
- Starting and shutting down mirroring:

Mirror destinations:

- The default state for a mirror destination service ID is shutdown. You must issue a **no shutdown** command to enable the feature.
- When a mirror destination service ID is shutdown, mirrored packets associated with the service ID are not accepted from its mirror source or remote source. The associated mirror source is put into an operationally down mode. Mirrored packets are not transmitted out the SAP or SDP. Each mirrored packet is silently discarded. If the mirror destination is a SAP, the SAP's discard counters are incremented.
- Issuing the `shutdown` command causes the mirror destination service or its mirror source to be put into an administratively down state. Mirror destination service IDs must be shut down first in order to delete a service ID, SAP, or SDP association from the system.

Mirror sources:

- The default state for a mirror source for a given mirror-dest service ID is `no shutdown`. Enter a `shutdown` command to deactivate (disable) mirroring from that mirror-source.
- Mirror sources do not need to be shutdown to remove them from the system. When a mirror source is shutdown, mirroring is terminated for all sources defined locally for the mirror destination service ID.

The following are lawful intercept configuration caveats.

Network management — Operators without LI permission cannot view or manage the LI data on the node nor can they view or manage the data on the Network Management platform.

LI mirroring does not allow the configuration of ports and ingress labels as a source parameter.

## Configuring Service Mirroring with CLI

This section provides information about service mirroring

Topics in this section include:

- [Mirror Configuration Overview on page 38](#)
- [Lawful Intercept Configuration Overview on page 40](#)
- [Basic Mirroring Configuration on page 46](#)
  - [Mirror Classification Rules on page 48](#)
- [Common Configuration Tasks on page 51](#)
  - [Configuring a Local Mirror Service on page 53](#)
  - [Configuring a Remote Mirror Service on page 57](#)
  - [Configuring SDPs on page 55](#)
  - [Configuring Lawful Intercept Parameters on page 61](#)
  - [Pseudowire Redundancy for Mirror Services Configuration Example on page 62](#)
- [Service Management Tasks on page 64](#)
  - [Modifying a Local Mirrored Service on page 66](#)
  - [Deleting a Local Mirrored Service on page 67](#)
  - [Modifying a Remote Mirrored Service on page 68](#)
  - [Deleting a Remote Mirrored Service on page 70](#)

## Mirror Configuration Overview

7750 SR mirroring can be organized in the following logical entities:

- The mirror source is defined as the location where ingress or egress traffic specific to a port, SAP, MAC or IP filter, ingress label or a subscriber is to be mirrored (copied). The original frames are not altered or affected in any way.
  - An SDP is used to define the mirror destination on the source router to point to a remote destination (another router).
  - A SAP is defined in local and remote mirror services as the mirror destination to where the mirrored packets are sent.
  - The subscriber contains hosts which are added to a mirroring service.
  -
- 

## Defining Mirrored Traffic

In some scenarios, like using VPN services or when multiple services are configured on the same port, specifying the port does not provide sufficient resolution to separate traffic. In Alcatel-Lucent's implementation of mirroring, multiple source mirroring parameters can be specified to further identify traffic.

Mirroring of packets matching specific filter entries in an IP or MAC filter can be applied to refine what traffic is mirrored to flows of traffic within a service. The IP criteria can be combinations of:

- Source IP address/mask
- Destination IP address/mask
- IP Protocol value
- Source port value/range (for example, UDP or TCP port)
- Destination port value/range (for example, UDP or TCP port)
- DiffServ Code Point (DSCP) value
- ICMP code
- ICMP type
- IP fragments
- IP option value/mask
- Single or multiple IP option fields present
- IP option fields present
- TCP ACK set/reset

- TCP SYN set/reset
- SAP ingress/egress labels

The MAC criteria can be combinations of:

- IEEE 802.1p value/mask
- Source MAC address/mask
- Destination MAC address/mask
- Ethernet Type II Ethernet type value
- Ethernet 802.2 LLC DSAP value/mask
- Ethernet 802.2 LLC SSAP value/mask
- IEEE 802.3 LLC SNAP Ethernet Frame OUI zero/non-zero value
- IEEE 802.3 LLC SNAP Ethernet Frame PID value
- SAP ingress/egress labels

## Lawful Intercept Configuration Overview

Lawful Intercept allows the user to access and execute commands at various command levels based on profiles assigned to the user by the administrator. LI must be configured in the **config>system>security>user>access** and **config>system>security>profile** contexts. The options include FTP, SNMP, console, and LI access.

LI parameters configured in the BOF context (**li-local-save** and **li-separate**) include the ability to access LI separately than the normal administrator. As with all BOF entities, changing the BOF file during normal system operation only results in the parameter being set for the next reboot. These BOF commands are initialized to the default values, **no li-separate** and **no-li-local-save**. A system boot is necessary for any change to the **li-separate** and **li-local-save** to become effective.

Changes to the **li-separate** and **li-local-save** configurations should be made in both primary and backup CM BOF files.

At regular intervals, a LI status event is generated by the system to indicate the mode of the LI administration, time of the last reboot, and whether local save is enabled.

---

## Saving LI Data

Depending on location and law enforcement preferences, the node can be configured to save all LI data on local media. If the operator saves this data then when starting/restarting the system the configuration file will be processed first then the LI configuration will be restarted.

When permitted to save the data, the data is encrypted and the encryption key is unique per system and is not visible to any administrator.

To save LI data locally, the option must be configured in the **bof>li-local-save** context. Enabling this option will only be applied after a system reboot.

If an LI save is permitted, then only a local save is permitted and, by default, it will be saved to Compact Flash 3 with the filename of "*li.cfg*". An explicit save command under the **config>li** context must be executed to save the LI. An LI administrator with privileges to configure LI, can execute the *li.cfg* file.

## Regulating LI Access

Depending on local regulations pertaining to Lawful Intercept (LI) a node can be configured to separate normal system administration tasks from tasks of a Lawful Intercept operator.

If the separation of access is not required and any administrator can manage lawful intercept or plain mirroring, then it is not necessary to configure the **li-separate** parameter in the BOF configuration. However, to ensure logical separation, the following must occur:

- An **administrator** must create a user and configure the user as LI capable (**config>system> security>user>access** context). Furthermore, the **administrator** must assure that both CLI and SNMP access permission is granted for the LI operator.
- Finally, before turning the system into two separate administration domains, the CLI user must be granted a profile that limits the LI operator to those tasks relevant to the job (**config>system> security>profile>li** context).

It is important to remember that the LI operator is the only entity who can grant LI permission to any other user once in **li-separate** mode.

Provided the above procedure is followed, the LI administrator must decide whether to allow the LI (source) configuration to be saved onto local media. This is also subject to local regulations.

At this point, the BOF file can be configured with the **li-separate** and **li-local-save** parameters. If the local save is not configured then the LI information must be reconfigured after a system reboot.

Assuming **li-separate** is configured, the node should be rebooted to activate the **separate** mode. At this point the system administrators without LI permission cannot modify, create or view any LI- specific configurations. In order for this to occur, the BOF file must be reconfigured and the system rebooted. This, combined with other features prohibits an unauthorized operator from modifying the administrative separation without notifying the LI administrator.

The following displays an SNMP example showing views, access groups, and attempts parameters.

```
A:ALA-23>config>system>security>snmp# info detail
-----
view iso subtree 1
  mask ff type included
exit
view no-security subtree 1
  mask ff type included
exit
view no-security subtree 1.3.6.1.6.3
  mask ff type excluded
exit
view no-security subtree 1.3.6.1.6.3.10.2.1
  mask ff type included
exit
view no-security subtree 1.3.6.1.6.3.11.2.1
```

## Configuring Service Mirroring with CLI

```
        mask ff type included
    exit
    view no-security subtree 1.3.6.1.6.3.15.1.1
        mask ff type included
    exit
...
    access group "snmp-li-ro" security-model usm security-level <security level>
context "li" read "li-view" notify "iso"
    access group "snmp-li-rw" security-model usm security-level <security level>
context "li" read "li-view" write "li-view" notify "iso"
    attempts 20 time 5 lockout 10
...
-----
A:ALA-23>config>system>security>snmp#
```

The following displays a user account configuration example.

```
A:ALA-23>config>system>security# info
-----
...
    user "liuser"
        access console snmp li
        console
            no member "default"
            member "liprofile"
        exit
        snmp
            authentication md5 <auth-key> privacy des <priv-key>
            group "snmp-li-rw"
        exit
    exit
...
-----
A:ALA-23>config>system>security#
```

---

## LI User Access

By default, LI user access is limited to those commands that are required to manage LI functionality. If a user is granted permission to access other configuration and operational data, then this must be explicitly configured in the user profile of the LI operator in the **config>system>security>profile>entry>match** *command-string* context. [Figure 11](#) depicts a flow as to set an LI operator.

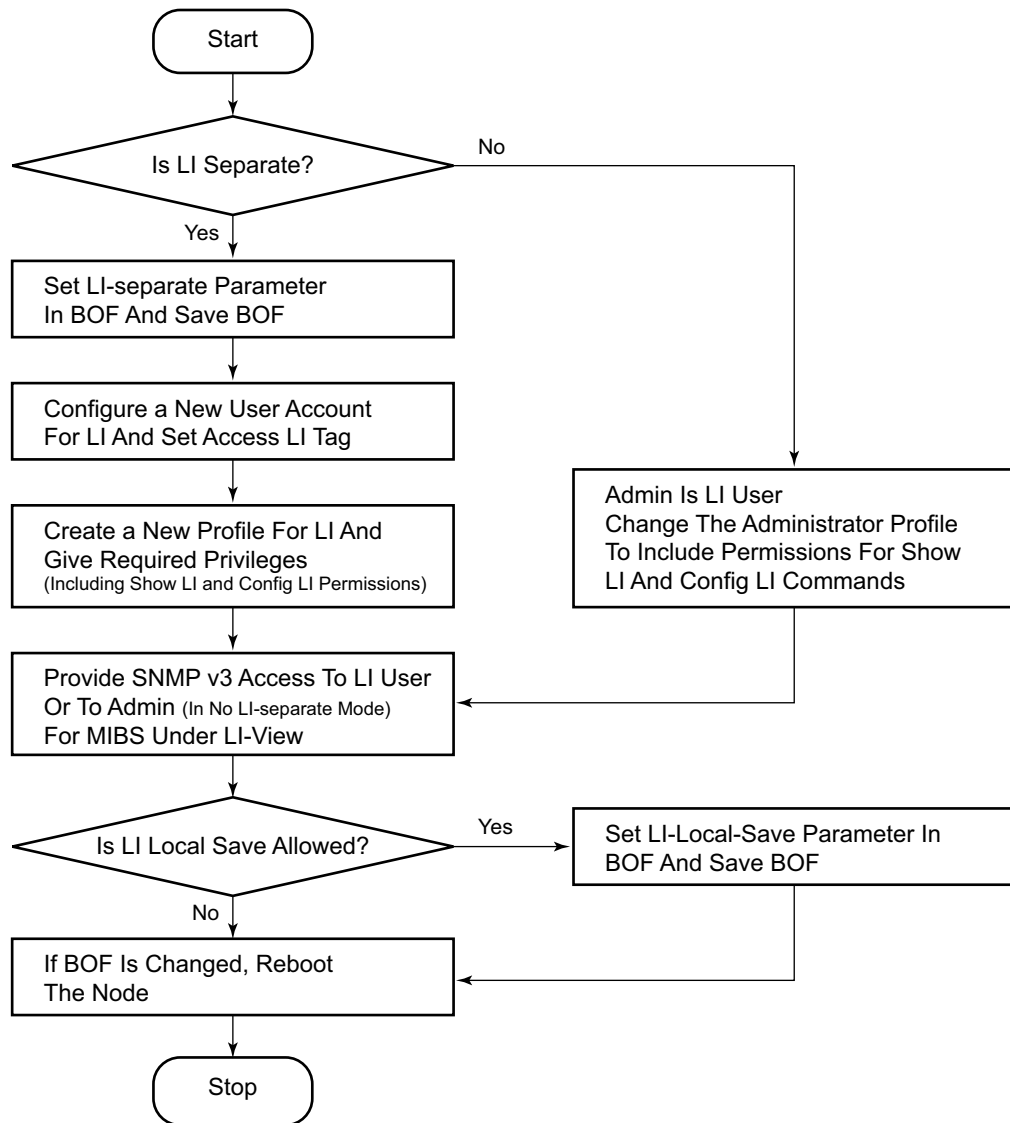

OSSG264

Figure 11: Creating an LI Operator Account

### LI Source Configuration

Filter configuration is accessible to both the LI operator and regular system administrators. If the content of a filter list that is subject to an LI operation and if a filter (included in the filter list) is used by an LI operator, its contents cannot be modified. If an attempt is made, then an LI event is generated. Only one mirror source can be attached to one mirror destination service. LI takes priority over debug mirror sources, So if a debug mirror source (for example, 10) exists and an LI mirror source is created with same ID 10, then the debug mirror source is silently discarded.

In the configuration, when an LI operator specifies that a given entry must be used as an LI entry then this fact is hidden from all non-LI operators. Modification of a filter entry is not allowed if it is used by LI. However, an event is generated, directed to the LI operator, indicating that the filter has been compromised.

Standard mirroring (non-LI) has a lower priority than LI instantiated mirroring. If a mirror source parameter (for example, SAP 1/1/1) exists and the same parameter is created in an LI source, the parameter is silently deleted from the debug mirror source.

The following order applies for both ingress and egress traffic:

- Port mirroring (debug only)
- SAP mirroring (debug or LI)
- Subscriber mirroring (debug or LI)
- Filter mirroring (debug or LI)

For frames from network ports:

- Port mirroring (debug only)
- Label mirroring (debug only, ingress only)
- Filter mirroring (debug or LI)

Filters can be created by all users that have access to the relevant CLI branches.

Once an LI mirror source using a given service ID is created and is in the **no shutdown** state, the corresponding mirror destination on the node cannot be modified (including **shutdown/no shutdown** commands) or deleted.

In the **separate** mode, the anonymity of the source is protected. Once source criterion is attached to the LI source, the following applies:

- In SAP configurations, only modifications that stop the flow of LI data while the customer receives data is blocked.
- In filter configurations, if a filter entry is attached to the LI source, modification and deletion of both the filter and the filter entry are blocked.

## LI Logging

A logging collector is supported in addition to existing main, security, change, and debug log collectors. LI log features include the following:

- Only visible to LI operators (such as show command output)
- Encrypted when transmitted (SNMPv3)
- Logging ability can only be created, modified, or deleted by an LI operator
- The LI user profile must include the ability to manage the LI functions

## Basic Mirroring Configuration

Destination mirroring parameters must include at least:

- A mirror destination ID (same as the mirror source service ID).
- A mirror destination SAP or SDP.

Mirror source parameters must include at least:

- A mirror service ID (same as the mirror destination service ID).
- At least one source type (port, SAP, ingress label, IP filter or MAC filter) specified.

The following example displays a sample configuration of a local mirrored service where the source and destinations are on the same device (ALA-A).

```
*A:ALA-A>config>mirror# info
-----
mirror-dest 103 create
  sap 2/1/25:0 create
  egress
  qos 1
  exit
exit
no shutdown
exit
-----
*A:ALA-A>config>mirror#
```

The following displays the mirror source configuration:

```
*A:ALA-A>debug>mirror-source# show debug mirror
debug
  mirror-source 103
  port 2/1/24 egress ingress
  no shutdown
  exit
exit
*A:ALA-A>debug>mirror-source# exit
```

The following example displays a sample configuration of a remote mirrored service where the source is a port on ALA-A and the destination a SAP is on ALA-B.

```
*A:ALA-A>config>mirror# info
-----
      mirror-dest 1000 create
          sdp 2 egr-svc-label 7000
          no shutdown
      exit
-----
*A:ALA-A>config>mirror# exit all
*A:ALA-A# show debug
debug
      mirror-source 1000
          port 2/1/2 egress ingress
          no shutdown
      exit
exit
*A:ALA-A#

*A:ALA-B>config>mirror# info
-----
      mirror-dest 1000 create
          remote-source
              far-end 10.10.10.104 ing-svc-label 7000
          exit
      sap 3/1/2:0 create
          egress
              qos 1
          exit
      exit
      no shutdown
      exit
-----
*A:ALA-B>config>mirror#
```

## Mirror Classification Rules

Alcatel-Lucent's implementation of mirroring can be performed by configuring parameters to select network traffic according to any of the following entities:

- [Port](#)
- [SAP](#)
- [MAC filter](#)
- [IP filter](#)
- [Ingress label](#)
- [Subscriber](#)

---

### Port

The `port` command associates a port to a mirror source. The port is identified by the port ID. The following displays the `port-id` syntax:

```

port-id:  slot/mda/port[.channel]
          aps-id      aps-group-id[.channel]
                   aps      keyword
                   group-id  1 — 64

          bundle-type-slot/mda.bundle-num
                   bundle   keyword
                   type     ima
                   bundle-num 1 — 128

          ccag-id - ccag-id.path-id[cc-type]:cc-id
                   ccag     keyword
                   id        1 — 8
                   path-id   a, b
                   cc-type   .sap-net, .net-sap
                   cc-id     0 — 4094

          lag-id     1 — 64
          egress     keyword
          ingress     keyword

```

The defined port can be Ethernet or Frame Relay port, a SONET/SDH path, a multilink bundle, a TDM channel, a Cross Connect Aggregation Group (CCAG), or a Link Aggregation Group (LAG) ID. If the port is a SONET/SDH or TDM channel, the channel ID must be specified to identify which channel is being mirrored. When a LAG ID is given as the port ID, mirroring is enabled on all ports making up the LAG. Ports that are ATM, circuit-emulation (CEM), and PPP bundle groups cannot be used in a mirror source.

Mirror sources can be ports in either access or network mode. Port mirroring is supported in the following combinations:

**Table 2: Mirror Source Port Requirements**

Port Type	Port Mode	Port Encap Type
faste/gige/xgige	access	dot1q, null
faste/gige/xgige	network	dot1q, null
SONET (clear/deep channel)	access	bcp-null, bcp-dot1q, ipcp
TDM (clear/deep channel)	access	bcp-null, bcp-dot1q, ipcp

**CLI Syntax:** `debug>mirror-source# port {port-id|lag lag-id} {[egress] [ingress]}`

**Example:** `*A:ALA-A>debug>mirror-source# port 2/2/2 ingress egress`

## SAP

More than one SAP can be associated within a single mirror-source. Each SAP has its own ingress and egress parameter keywords to define which packets are mirrored to the mirror-dest service ID. A SAP that is defined within a mirror destination cannot be used in a mirror source.

**CLI Syntax:** `debug>mirror-source# sap sap-id {[egress] [ingress]}`

**Example:** `*A:ALA-A>debug>mirror-source# sap 2/1/4:100 ingress egress`

or `debug>mirror-source# port 2/2/1.sts12 ingress`

## Basic Mirroring Configuration

**MAC filter** MAC filters are configured in the **config>filter>mac-filter** context. The **mac-filter** command causes all the packets matching the explicitly defined list of entry IDs to be mirrored to the mirror destination specified by the service-id of the mirror source.

**CLI Syntax:** `debug>mirror-source# mac-filter mac-filter-id entry entry-id [entry-id ...]`

**Example:** `*A:ALA-2>debug>mirror-source# mac-filter 12 entry 15 20 25`

---

**IP filter** IP filters are configured in the **config>filter>ip-filter** context. The **ip-filter** command causes all the packets matching the explicitly defined list of entry IDs to be mirrored to the mirror destination specified by the service-id of the mirror source.

Ingress mirrored packets are mirrored to the mirror destination prior to any ingress packet modifications. Egress mirrored packets are mirrored to the mirror destination after all egress packet modifications.

**CLI Syntax:** `debug>mirror-source# ip-filter ip-filter-id entry entry-id [entry-id ...]`

**Example:** `*A:ALA-A>debug>mirror-source# ip-filter 1 entry 20`

NOTE: An IP filter cannot be applied to a mirror destination SAP.

---

**Ingress label**

The **ingress-label** command is used to mirror ingressing MPLS frames with the specified MPLS labels. The ingress label must be at the top of the label stack and can only be mirrored to a single mirror destination. If the same label is defined with multiple mirror destinations, an error is generated and the original mirror destination does not change. The **ingress-label** allows packets matching the ingress label to be duplicated (mirrored) and forwarded to the mirror destination. The ingress label has to be active before it can be used as mirror source criteria. If the ingress label is not used in the router, the mirror source will remove the ingress label automatically.

**CLI Syntax:** `debug>mirror-source# ingress-label label [label...]`

**Example:** `*A:ALA-A>debug>mirror-source# ingress-label 103000 1048575`

---

**Subscriber** The subscriber command is used to add hosts of a subscriber to a mirroring service.

**CLI Syntax:** `debug>mirror-source# subscriber sub-ident-string [sap...]`

## Common Configuration Tasks

This section provides a brief overview of the tasks that must be performed to configure both local and remote mirror services and provides the CLI command syntax. Note that local and remote mirror source and mirror destination components must be configured under the same service ID context.

Each local mirrored service (Figure 12) (within the same router) requires the following configurations:

1. Specify mirror destination (SAP).
2. Specify mirror source (port, SAP, IP filter, MAC filter, ingress label, subscriber).

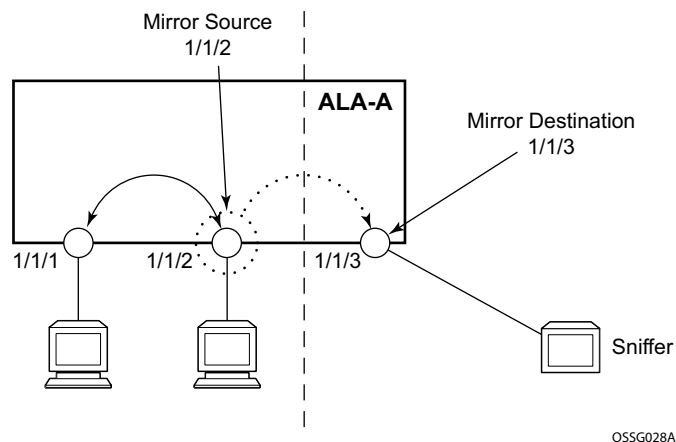
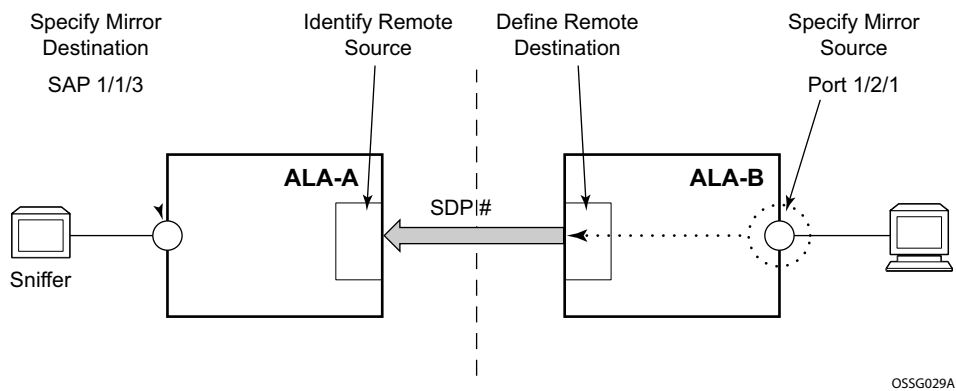

Figure 12: Local Mirrored Service Tasks

Each remote mirrored service (Figure 13) (across the network core) requires the following configurations:

1. Define the remote destination (SDP)
2. Identify the remote source (the device allowed to mirror traffic to this device)
3. Specify the mirror destination (SAP)
4. Specify mirror source (port, SAP, IP filter, MAC filter, ingress label, subscriber)



**Figure 13: Remote Mirrored Service Configuration Example**

## Configuring a Local Mirror Service

To configure a local mirror service, the source and destinations must be located on the same router. Note that local mirror source and mirror destination components must be configured under the same service ID context.

The **mirror-source** commands are used as traffic selection criteria to identify traffic to be mirrored at the source. Each of these criteria are independent. For example, use the **debug>mirror-source>port** *{port-id | lag lag-id}* **{[egress] [ingress]}** command and **debug>mirror-source ip-filter** *ip-filter-id entry entry-id [entry-id...]* command to capture (mirror) traffic that matches a specific IP filter entry and traffic ingressing and egressing a specific port. A filter must be applied to the SAP or interface if only specific packets are to be mirrored. Note that slice-size is not supported by CEM encap-types or IP-mirroring.

Use the CLI syntax to configure one or more mirror source parameters:

The **mirror-dest** commands are used to specify where the mirrored traffic is to be sent, the forwarding class, and the size of the packet. Use the following CLI syntax to configure mirror destination parameters:

**CLI Syntax:** `config>mirror mirror-dest service-id [type {ether|frame-relay|ppp|ip-only|atm-sdu|satop-e1|satop-t1|cesopsn|cesopsn-cas}] [create] description string fc fc-name sap sap-id [create] slice-size bytes no shutdown`

**CLI Syntax:** `debug# mirror-source service-id ip-filter ip-filter-id entry entry-id [entry-id ...] ingress-label label [label ...] mac-filter mac-filter-id entry entry-id [entry-id ...] port {port-id|lag lag-id} {[egress][ingress]} sap sap-id {[egress][ingress]} subscriber sub-ident-string [sap sap-id [ip ip-address] [mac ieee-address]|sla-profile sla-profile-name] [fc {[be] [l2] [af] [l1] [h2] [ef] [h1] [nc]}] {[ingress] [egress]} no shutdown`

**CLI Syntax:** `config>li li-source service-id ip-filter ip-filter-id entry entry-id [entry-id ...] mac-filter mac-filter-id entry entry-id [entry-id ...] sap sap-id {[ingress] [egress]} subscriber sub-ident-string [sap sap-id [ip ip-address] [mac ieee-address]|sla-profile sla-profile-name] [fc {[be] [l2] [af] [l1] [h2] [ef] [h1] [nc]}] {[in-`

## Common Configuration Tasks

```
gress] [egress]}  
no shutdown
```

The following output displays an example of a local mirrored service. On ALA-A, mirror service 103 is mirroring traffic matching IP filter 2, entry 1 as well as egress and ingress traffic on port 2/1/24 and sending the mirrored packets to SAP 2/1/25.

```
*A:ALA-A>config>mirror# info  
-----  
mirror-dest 103 create  
  sap 2/1/25:0 create  
    egress  
      qos 1  
    exit  
  exit  
no shutdown  
exit  
-----  
*A:ALA-A>config>mirror#
```

The following displays the debug mirroring information:

```
*A:ALA-A>debug>mirror-source# show debug mirror  
debug  
  mirror-source 103  
    no shutdown  
    port 2/1/24 egress ingress  
    ip-filter 2 entry 1  
  exit  
exit  
*A:ALA-A>debug>mirror-source# exit
```

## Configuring SDPs

This section provides a brief overview of the tasks that must be performed to configure SDPs and provides the CLI commands. For more information about service configuration, refer to the Subscriber Services chapter.

Consider the following SDP characteristics:

- Configure either GRE or MPLS SDPs.
- Each distributed service must have an SDP defined for every remote SR to provide Epipe, VPLS, or mirrored services.
- A distributed service must be bound to an SDP. By default, no SDP is associated with a service. Once an SDP is created, services can be associated to that SDP.
- An SDP is not specific to any one service or any type of service. An SDP can have more than one service bound to it.
- The SDP IP address must be a 7750 SR system IP address.
- In order to configure an MPLS SDP, LSPs must be configured first and then the LSP-to-SDP association must be explicitly created.

To configure a basic SDP, perform the following steps:

1. Select an originating node.
2. Create an SDP ID.
  1. Select an encapsulation type.
  2. Select the far-end node.

To configure the return path SDP, perform the same steps on the far-end 7750 SR router.

1. Select an originating node.
2. Create an SDP ID.
3. Select an encapsulation type.
4. Select the far-end node.

Use the following CLI syntax to create an SDP and select an encapsulation type. If you do not specify GRE or MPLS, the default encapsulation type is GRE.

**NOTE:** When you specify the far-end ip address, you are creating the tunnel. In essence, you are creating the path from Point A to Point B. When you configure a distributed Epipe SAP, you must identify an SDP ID. Use the `show service sdp` command to display the qualifying SDPs.

**CLI Syntax:**

```
config>service# sdp sdp-id [gre | mpls] create
description description-string
far-end ip-addr
lsp lsp-name [lsp-name]
path-mtu octets
no shutdown
keep-alive
    hello-time seconds
    hold-down-time seconds
    max-drop-count count
    message-length octets
no shutdown
```

On the mirror-source router, configure an SDP pointing toward the mirror-destination router (or use an existing SDP).

On the mirror-destination router, configure an SDP pointing toward the mirror-source router (or use an existing SDP).

The following example displays SDP configurations on both the mirror-source and mirror-destination routers.

```
*A:ALA-A>config>service# info
-----
sdp 1 create
description "to-10.10.10.104"
far-end 10.10.10.104
no shutdown
exit
-----
*A:ALA-A>config>service#

*A:ALA-B>config>service# info
-----
sdp 4 create
description "to-10.10.10.103"
far-end 10.10.10.103
no shutdown
exit
-----
*A:ALA-B>config>service#
```

## Configuring a Remote Mirror Service

For remote mirroring, the source and destination are configured on the different routers. Note that mirror source and mirror destination parameters must be configured under the same service ID context.

The **mirror-source** commands are used as traffic selection criteria to identify traffic to be mirrored at the source. For example, use the **port** *port-id* [*channel-id*] {[**egress**] [**ingress**] } and **mac-filter** *mac-filter-id* **entry** *entry-id* [*entry-id* ...] commands.

Use the CLI syntax to configure one or more mirror source parameters:

```
CLI Syntax: debug> mirror-source service-id
    ip-filter ip-filter-id entry entry-id [entry-id ...]
    ingress-label label [label ...]
    mac-filter mac-filter-id entry entry-id [entry-id ...]
    port {port-id|lag lag-id} {[egress][ingress]}
    sap sap-id {[egress][ingress]}
    sdp sap-id[:vc-id] {[egress] [ingress]}
    subscriber sub-ident-string [sap sap-id [ip ip-address] [mac
    ieee-address] |sla-profile sla-profile-name] [fc {[be] [l2]
    [af] [l1] [h2] [ef] [h1] [nc] }]} {[ingress] [egress]}
    no shutdown
```

The **mirror-dest** commands are used to specify where the mirrored traffic is to be sent, the forwarding class, and the size of the packet. Use the following CLI syntax to configure mirror destination parameters:

```
CLI Syntax: config>mirror#
    mirror-dest service-id [type {ether|frame-relay|ppp|ip-on-
    ly|atm-sdu|satop-e1|satop-t1|cesopsn|cesopsn-cas}]
    description string
    fc fc-name
    remote-source
        far-end ip-addr ing-svc-label ing-svc-label
    sap sap-id
    sdp sdp-id[:vc-id] [egr-svc-label [label|tldp]
    no shutdown
    slice-size bytes
```

```
CLI Syntax: config>li
    li-source service-id
    ip-filter ip-filter-id entry entry-id [entry-id ...]
    mac-filter mac-filter-id entry entry-id [entry-id ...]
    port {port-id|lag lag-id} {[egress][ingress]}
    subscriber sub-ident-string [sap sap-id [ip ip-address]
```

```

[mac ieee-address]|sla-profile sla-profile-name]
[fc {[be] [l2] [af] [l1] [h2] [ef] [h1] [nc]}} {[in-
gress] [egress]}
no shutdown
    
```

The following displays the mirror destination, which is on ALA-A, configuration for mirror service 1216. This configuration specifies that the mirrored traffic coming from the mirror source (10.10.0.91) is to be directed to SAP 4/1/58 and states that the service only accepts traffic from far end 10.10.0.92 (ALA-B) with an ingress service label of 5678. When a forwarding class is specified, then all mirrored packets transmitted to the destination SAP or SDP override the default (be) forwarding class. The slice size limits the size of the stream of packet through the 7750 SR and the core network.

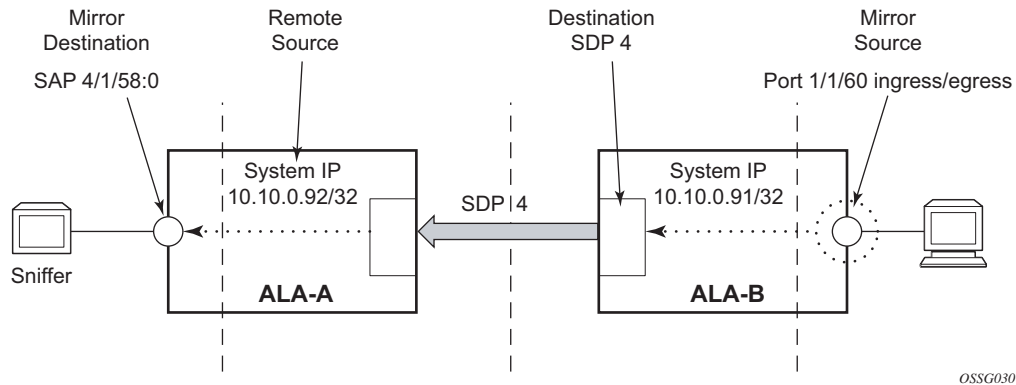

**Figure 14: Remote Mirrored Service Tasks**

The following example displays the CLI output showing the configuration of remote mirrored service 1216. The traffic ingressing and egressing port 1/1/60 on 10.10.0.92 (ALA-B) will be mirrored to the destination SAP 1/1/58:0 on ALA-A.

The following displays the mirror destination configuration for mirror service 1216 on ALA-A.

```

*A:ALA-A>config>mirror# info
-----
mirror-dest 1216 create
  description "Receiving mirror traffic from .91"
  remote-source
    far-end 10.10.0.91 ing-svc-label 5678
  exit
  sap 1/1/58:0 create
    egress
      qos 1
    exit
  exit
  no shutdown
exit
    
```

```
-----
*A:ALA-A>config>mirror#
```

The following displays the remote mirror destination configured on ALA-B:

```
*A:ALA-B>config>mirror# info
-----
mirror-dest 1216 create
  description "Sending mirrored traffic to .92"
  fc h1
  sdp 4 egr-svc-label 5678
  slice-size 128
  no shutdown
exit
```

```
-----
*A:ALA-B>config>mirror#
```

The following displays the mirror source configuration for ALA-B:

```
*A:ALA-B# show debug mirror
debug
  mirror-source 1216
  port 1/1/60 egress ingress
  no shutdown
exit
exit
*A:ALA-B#
```

The following displays the SDP configuration from ALA-A to ALA-B (SDP 2) and the SDP configuration from ALA-B to ALA-A (SDP 4).

```
*A:ALA-A>config>service>sdp# info
-----
description "GRE-10.10.0.91"
far-end 10.10.0.01
no shutdown
```

```
-----
*A:ALA-A>config>service>sdp#
```

```
*A:ALA-B>config>service>sdp# info
-----
description "GRE-10.10.20.92"
far-end 10.10.10.103
no shutdown
```

```
-----
*A:ALA-B>config>service>sdp#
```

## Configuring an ATM Mirror Service

Configure a local ATM mirror service at PE1:

```
Example: config>mirror# mirror-dest 1 type atm-sdu create
config>mirror>mirror-dest# sap 1/2/1:1/101 create
config>mirror>mirror-dest>sap# no shutdown
config>mirror>mirror-dest>sap# exit all
# debug
debug# mirror-source 1
debug>mirror-source# sap 2/1/1/:0/100 ingress
```

Configure a remote ATM mirror service at PE1:

```
Example: config>mirror# mirror-dest 1 type atm-sdu create
config>mirror>mirror-dest# sdp 1:20
config>mirror>mirror-dest# exit all
# debug

debug# mirror-source 1
debug>mirror-source# sap 2/1/1/:0/100 ingress
```

Configure a remote ATM mirror service at PE2:

```
Example: config>mirror# mirror-dest 1 type atm-sdu create
config>mirror>mirror-dest# remote-source
config>mirror>mirror-dest>remote-source# far-end 10.10.10.10
config>mirror>mirror-dest>remote-source# exit
config>mirror>mirror-dest# sap 1/2/1:1/101 create
```

## Configuring Lawful Intercept Parameters

The following display LI source configuration and LI log configuration examples.

```
A:ALA-48>config# info
#-----
...
(LI Source Config)
  li-source 1
    sap 1/5/5:1001 egress ingress
    no shutdown
  exit
  li-source 2
    subscriber "test" sla-profile "test" fc l2 ingress egress
    no shutdown
  exit
  li-source 3
    mac-filter 10 entry 1
    no shutdown
  exit
  li-source 4
    ip-filter 11 entry 1
    no shutdown
  exit
...
(LI Log Config)
  log-id 1
    filter 1
    from li
    to session
  exit
  log-id 11
    from li
    to memory
  exit
  log-id 12
    from li
    to snmp
  exit
...
#-----
A:ALA-48>config#
```

## Pseudowire Redundancy for Mirror Services Configuration Example

A configuration based on [Figure 15](#) is described.

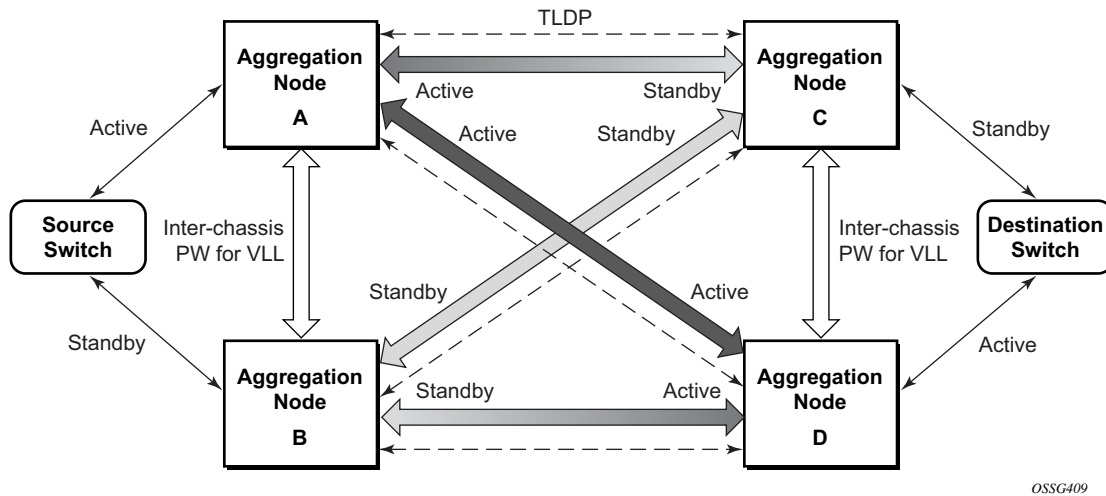

**Figure 15: State Engine for Redundant Service to a Redundant Mirror Service**

The mirror traffic needs to be forwarded from configured debug mirror-source together with mirror-dest/remote-source (icb or non-icb) to either SAP endpoint or SDP endpoint.

A SAP endpoint is an endpoint with a SAP and with or without an additional icb spoke. An SDP endpoint is an endpoint with regular and icb spokes.

Only one tx-active will be chosen for either SAP endpoint or SDP endpoint. Traffic ingressing into a remote-source icb will have only ingressing traffic while an icb spoke will have only egressing traffic.

The ingressing traffic to a remote-source icb cannot be forwarded out of another icb spoke.

```
Node A:
config mirror mirror-dest 100
endpoint X
sdp to-C endpoint X
sdp to-D endpoint X
sdp to-B endpoint X icb // connects to B's remote-source IP-A, traffic A->B only
remote-source IP-B icb // connects to B's sdp to-A, traffic B->A only
```

```
Node B:
config mirror mirror-dest 100
endpoint X
```

```
sdp to-C endpoint X
sdp to-D endpoint X
sdp to-A endpoint X icb // connects to A's remote-source IP-B, traffic B->A only
remote-source IP-A icb // connects to Node A's sdp to-B, traffic A->B only
```

Node C:

```
config mirror mirror-dest 100
endpoint X
sap lag-1:0 endpoint X
sdp to-D endpoint X icb // connects to D's remote-source IP-C, traffic C->D only
remote-source IP-A
remote-source IP-B
remote-source IP-D icb // connects to D's sdp to-C, traffic D->C only
```

Node D:

```
config mirror mirror-dest 100
endpoint X
sap lag-1:0 endpoint X
sdp to-C endpoint X icb // connects to C's remote-source IP-D, traffic D->C only
remote-source IP-A
remote-source IP-B
remote-source IP-C icb // connects to C's sdp to-D, traffic C->D only
```

## Service Management Tasks

This section discusses the following service management tasks:

- [Modifying a Local Mirrored Service on page 66](#)
- [Deleting a Local Mirrored Service on page 67](#)
- [Modifying a Remote Mirrored Service on page 68](#)
- [Deleting a Remote Mirrored Service on page 70](#)

Use the following command syntax to modify an existing mirrored service:

**CLI Syntax:** config>mirror#  
 mirror-dest *service-id* [type {ether|frame-relay|ppp|ip-only|atm-sdu|atm-sdu|satop-e1|satop-t1|cesopsn|cesopsn-cas}]  
 description *description-string*  
 no description  
 fc *fc-name*  
 no fc  
 remote-source  
     far-end *ip-address* [ing-svc-label *ing-svc-label*|tldp]  
     no far-end *ip-address*  
 sap *sap-id*  
 no sap  
 sdp *sdp-name* [egr-svc-label *egr-svc-label*|tldp]  
 no sdp  
 [no] shutdown

**CLI Syntax:** debug  
 [no] mirror-source *service-id*  
 ip-filter *ip-filter-id* entry *entry-id* [*entry-id...*]  
 no ip-filter *ip-filter-id*  
 no ip-filter entry *entry-id* [*entry-id...*]  
 ingress-label *label* [*label*]  
 no ingress-label  
 no ingress-label *label* [*label*]  
 mac-filter *mac-filter-id* entry *entry-id* [*entry-id...*]  
 no mac-filter *mac-filter-id*  
 no mac-filter *mac-filter-id* entry *entry-id* [*entry-id...*]  
 [no] port {*port-id*|lag *lag-id*} {[egress][ingress]}  
 [no] sap *sap-id* {[egress] [ingress]}  
 [no] shutdown

**CLI Syntax:** config>li  
 li-source *service-id*  
 ip-filter *ip-filter-id* entry *entry-id* [*entry-id ...*]  
 mac-filter *mac-filter-id* entry *entry-id* [*entry-id ...*]

```
sap sap-id {[ingress] [egress]}
subscriber sub-ident-string [sap sap-id [ip ip-address]
    [mac ieee-address]|sla-profile sla-profile-name]
    [fc {[be] [l2] [af] [l1] [h2] [ef] [h1] [nc]}] {[in-
    gress] [egress]}
no shutdown
```

## Modifying a Local Mirrored Service

Existing mirroring parameters can be modified in the CLI. The changes are applied immediately. The service must be shut down if changes to the SAP are made.

The following example displays commands to modify parameters for a basic local mirroring service.

```
Example:config>mirror# mirror-dest 103
config>mirror>mirror-dest# shutdown
config>mirror>mirror-dest# no sap
config>mirror>mirror-dest# sap 3/1/5:0 create
config>mirror>mirror-dest>sap$ exit
config>mirror>mirror-dest# fc be
config>mirror>mirror-dest# slice-size 128
config>mirror>mirror-dest# no shutdown

debug# mirror-dest 103
debug>mirror-source# no port 2/1/24 ingress egress
debug>mirror-source# port 3/1/7 ingress egress
```

The following displays the local mirrored service modifications:

```
*A:ALA-A>config>mirror# info
-----
mirror-dest 103 create
  no shutdown
  fc be
  remote-source
  exit
  sap 3/1/5:0 create
    egress
    qos 1
  exit
  exit
  slice-size 128
  exit

*A:ALA-A>debug>mirror-source# show debug mirror
debug
  mirror-source 103
  no shutdown
  port 3/1/7 egress ingress
  exit
*A:ALA-A>debug>mirror-source#
```

## Deleting a Local Mirrored Service

Existing mirroring parameters can be deleted in the CLI. A shutdown must be issued on a service level in order to delete the service. It is not necessary to shut down or remove SAP or port references to delete a local mirrored service.

The following example displays commands to delete a local mirrored service.

```
Example:ALA-A>config>mirror# mirror-dest 103
config>mirror>mirror-dest# shutdown
config>mirror>mirror-dest# exit
config>mirror# no mirror-dest 103
config>mirror# exit
```

## Modifying a Remote Mirrored Service

Existing mirroring parameters can be modified in the CLI. The changes are applied immediately. The service must be shut down if changes to the SAP are made.

In the following example, the mirror destination is changed from 10.10.10.2 (ALA-B) to 10.10.10.3 (SR3). Note that the mirror-dest service ID on ALA-B must be shut down first before it can be deleted.

The following example displays commands to modify parameters for a remote mirrored service.

```
Example:*A:ALA-A>config>mirror# mirror-dest 104
config>mirror>mirror-dest# remote-source
config>mirror>mirror-dest>remote-source# no far-end 10.10.10.2
remote-source# far-end 10.10.10.3 ing-svc-label 3500
```

```
*A:ALA-B>config>mirror# mirror-dest 104
config>mirror>mirror-dest# shutdown
config>mirror>mirror-dest# exit
config>mirror# no mirror-dest 104
```

```
SR3>config>mirror# mirror-dest 104 create
config>mirror>mirror-dest# sdp 4 egr-svc-label 3500
config>mirror>mirror-dest# no shutdown
config>mirror>mirror-dest# exit all
```

```
SR3># debug
debug# mirror-source 104
debug>mirror-source# port 551/1/2 ingress egress
debug>mirror-source# no shutdown
```

```
*A:ALA-A>config>mirror# info
-----
mirror-dest 104 create
  remote-source
    far-end 10.10.10.3 ing-svc-label 3500
  exit
  sap 2/1/15:0 create
    egress
      qos 1
    exit
  exit
  no shutdown
exit
```

```
A:SR3>config>mirror# info
-----
mirror-dest 104 create
  sdp 4 egr-svc-label 3500
  no shutdown
```

```
exit
```

```
-----  
A:SR3>config>mirror#
```

```
A:SR3# show debug mirror  
debug  
  mirror-source 104  
    no shutdown  
    port 5/1/2 egress ingress
```

## Deleting a Remote Mirrored Service

Existing mirroring parameters can be deleted in the CLI. A shut down must be issued on a service level in order to delete the service. It is not necessary to shut down or remove SAP, SDP, or far-end references to delete a remote mirrored service.

Mirror destinations must be shut down first before they can be deleted.

```
Example:*A:ALA-A>config>mirror# mirror-dest 105
config>mirror>mirror-dest# shutdown
config>mirror>mirror-dest# exit
config>mirror# no mirror-dest 105
config>mirror# exit

*A:ALA-B>config>mirror# mirror-dest 105
config>mirror>mirror-dest# shutdown
config>mirror>mirror-dest# exit
config>mirror# no mirror-dest 105
config>mirror# exit
```

The mirror-destination service ID 105 was removed from the configuration on ALA-A and ALA-B, thus, does not appear in the `info` command output.

```
*A:ALA-A>config>mirror# info
-----
-----
*A:ALA-A>config>mirror# exit

*A:ALA-B>config>mirror# info
-----
-----
*A:ALA-B>config>mirror# exit
```

Since the mirror destination was removed from the configuration on ALA-B, the port information was automatically removed from the `debug mirror-source` configuration.

```
*A:ALA-B# show debug mirror
debug
exit
*A:ALA-B#
```

---

# Mirror Service Command Reference

---

## Command Hierarchies

- [Mirror Configuration Commands on page 71](#)
- [Lawful Intercept Commands on page 72](#)
- [Debug Commands on page 72](#)
- [Show Commands on page 73](#)

## Mirror Configuration Commands

```

config
  — mirror
    — mirror-dest service-id [type encap-type]
    — no mirror-dest service-id
      — description description-string
      — no description
      — [no] enable-port-id
      — endpoint endpoint-name [create]
      — no endpoint endpoint-name
        — description description-string
        — no description
        — revert-time {revert-time | infinite}
        — no revert-time
      — fc fc-name
      — no fc
      — [no] remote-source
        — far-end ip-address [ing-svc-label ing-vc-label | tdp]
        — no far-end ip-address
      — sap sap-id [create] [no-endpoint]
      — sap sap-id [create] endpoint name
      — no sap
        — cem
          — packet jitter-buffer milliseconds [payload-size bytes]
          — packet payload-size bytes
          — no packet
          — [no] rtp-header
        — egress
          — ip-mirror
            — sa-mac ieee-address da-mac ieee-address
            — no sa-mac
          — qos policy-id
          — no qos
        — slice-size bytes
        — no slice-size
      — spoke-sdp sdp-id:vc-id [create] [no-endpoint]

```

- **spoke-sdp** *sdp-id:vc-id* [**create**] **endpoint** *name* [**icb**]
- **no spoke-sdp** *sdp-id:vc-id*
  - **egress**
    - **vc-label** *egress-vc-label*
    - **no vc-label** [*egress-vc-label*]
  - **precedence** *precedence-value* | **primary**
  - **no precedence**
  - [**no**] **shutdown**
- [**no**] **shutdown**

## Debug Commands

- debug**
  - [**no**] **mirror-source** *mirror-dest-service-id*
    - **ingress-label** *label* [*label ...up to 8 max*]
    - **no ingress-label** [*label [label ...up to 8 max]*]
    - **ip-filter** *ip-filter-id* **entry** *entry-id* [*entry-id ...*]
    - **no ip-filter** *ip-filter-id* [**entry** *entry-id*] [*entry-id ...*]
    - **mac-filter** *mac-filter-id* **entry** *entry-id* [*entry-id ...*]
    - **no mac-filter** *mac-filter-id* [**entry** *entry-id...*]
    - **port** {*port-id* | **lag** *lag-id*} {[**egress**] [**ingress**]}
    - **no port** {*port-id* | **lag** *lag-id*} [**egress**] [**ingress**]
    - **sap** *sap-id* {[**egress**] [**ingress**]}
    - **no sap** *sap-id* [**egress**] [**ingress**]
    - **subscriber** *sub-ident-string* [**sap** *sap-id*] [**ip** *ip-address*] [**mac** *ieee-address*] |**sla-profile** *sla-profile-name*] [**fc** {[**be**] [**I2**] [**af**] [**I1**] [**h2**] [**ef**] [**h1**] [**nc**]}] {[**ingress**] [**egress**]}
    - **no subscriber** *sub-ident-string*
    - [**no**] **shutdown**

## Lawful Intercept Commands

- config**
  - **li**
    - **li-source** *service-id*
      - **ip-filter** *ip-filter-id* **entry** *entry-id* [*entry-id...*]
      - **no ip-filter** *ip-filter-id* [**entry** *entry-id...*]
      - **mac-filter** *mac-filter-id* **entry** *entry-id* [*entry-id...*]
      - **no mac-filter** *mac-filter-id* [**entry** *entry-id...*]
      - **sap** *sap-id* {[**ingress**] [**egress**]}
      - **no sap** *sap-id* [**ingress**] [**egress**]
      - [**no**] **shutdown**
      - **subscriber** *sub-ident-string* [**sap** *sap-id*] [**ip** *ip-address*] [**mac** *ieee-address*] |**sla-profile** *sla-profile-name*] [**fc** {[**be**] [**I2**] [**af**] [**I1**] [**h2**] [**ef**] [**h1**] [**nc**]}] {[**ingress**] [**egress**]}
      - **no subscriber** *sub-ident-string*
    - **log**
      - [**no**] **log-id** *log-id*
        - **description** *description-string*
        - **no description**
        - **filter** *filter-id*

- **no filter**
- **from** {[li]}
- **no from**
- **[no] shutdown**
- **time-format** {local | utc}
- **to memory** [size]
- **to session**
- **to snmp** [size]
- **save**

The following commands are also described in the 7750 SR OS Basic System Configuration Guide .

- ```
config
  — bof
    — [no] li-local-save
    — [no] li-separate
```

The following commands are also described in the 7750 SR OS System Management Configuration Guide.

- ```
config
  — system
    — security
      — user
        — [no] access [ftp] [snmp] [console] [li]
        — [no] profile user-profile-name
        — [no] li
```

## Show Commands

- ```
show
  — debug [application]
  — mirror mirror-dest [service-id]
  — li
    — li-source [service-id]
    — log
      — log-id [log-id] [severity severity-level] [application application] [sequence from-
        seq [to-seq]] [count count] [router router-instance [expression]] [subject subject
        [regexp]] [ascending | descending]
    — status
  — service
    — active-subscribers summary
    — active-subscribers [subscriber sub-ident-string [sap sap-id sla-profile sla-profile-name]]
      [detail|mirror]
    — active-subscribers hierarchy [subscriber sub-ident-string]
    — service-using mirror
```



---

## Configuration Commands

---

### Generic Commands

#### description

|                    |                                                                                                                                                                                                                                                                                               |
|--------------------|-----------------------------------------------------------------------------------------------------------------------------------------------------------------------------------------------------------------------------------------------------------------------------------------------|
| <b>Syntax</b>      | <b>description</b> <i>description-string</i><br><b>no description</b>                                                                                                                                                                                                                         |
| <b>Context</b>     | config>mirror>mirror-dest<br>config>li>log>log-id                                                                                                                                                                                                                                             |
| <b>Description</b> | This command creates a text description stored in the configuration file for a configuration context to help the administrator identify the content of the file.<br><br>The <b>no</b> form of the command removes the description string.                                                     |
| <b>Default</b>     | There is no default description associated with the configuration context.                                                                                                                                                                                                                    |
| <b>Parameters</b>  | <i>description-string</i> — The description character string. Allowed values are any string up to 80 characters long composed of printable, 7-bit ASCII characters. If the string contains special characters (#, \$, spaces, etc.), the entire string must be enclosed within double quotes. |

#### shutdown

|                    |                                                                                                                                                                                                                                                                                                                                                                                                                                                                                                                                                                                                                                                                                                                                                                                                                                  |
|--------------------|----------------------------------------------------------------------------------------------------------------------------------------------------------------------------------------------------------------------------------------------------------------------------------------------------------------------------------------------------------------------------------------------------------------------------------------------------------------------------------------------------------------------------------------------------------------------------------------------------------------------------------------------------------------------------------------------------------------------------------------------------------------------------------------------------------------------------------|
| <b>Syntax</b>      | <b>[no] shutdown</b>                                                                                                                                                                                                                                                                                                                                                                                                                                                                                                                                                                                                                                                                                                                                                                                                             |
| <b>Context</b>     | config>mirror>mirror-dest<br>debug>mirror-source<br>config>mirror>mirror-dest>spoke-sdp>egress<br>config>li>li-source<br>config>li>log>log-id                                                                                                                                                                                                                                                                                                                                                                                                                                                                                                                                                                                                                                                                                    |
| <b>Description</b> | The <b>shutdown</b> command administratively disables an entity. When disabled, an entity does not change, reset, or remove any configuration settings or statistics. Many entities must be explicitly enabled using the <b>no shutdown</b> command.<br><br>The <b>shutdown</b> command administratively disables an entity. The operational state of the entity is disabled as well as the operational state of any entities contained within. Many objects must be shut down before they may be deleted.<br><br>Unlike other commands and parameters where the default state is not indicated in the configuration file, <b>shutdown</b> and <b>no shutdown</b> are always indicated in system generated configuration files.<br><br>The <b>no</b> form of the command puts an entity into the administratively enabled state. |
| <b>Default</b>     | See Special Cases below.                                                                                                                                                                                                                                                                                                                                                                                                                                                                                                                                                                                                                                                                                                                                                                                                         |

**Special Cases**    **Mirror Destination** — When a mirror destination service ID is shutdown, mirrored packets associated with the service ID are not accepted from the mirror source or remote source 7750 SR router. The associated mirror source is put into an operationally down mode. Mirrored packets are not transmitted out of the SAP or SDP. Each mirrored packet is silently discarded. If the mirror destination is a SAP, the SAP's discard counters are incremented.

The **shutdown** command places the mirror destination service or mirror source into an administratively down state. The **mirror-dest** service ID must be shut down in order to delete the service ID, SAP or SDP association from the system.

The default state for a mirror destination service ID is **shutdown**. A **no shutdown** command is required to enable the service.

**Mirror Source** — Mirror sources do not need to be shutdown in order to remove them from the system.

When a mirror source is **shutdown**, mirroring is terminated for all sources defined locally for the **mirror-dest** service ID. If the **remote-source** command has been executed on the **mirror-dest** associated with the shutdown **mirror-source**, mirroring continues for remote sources.

The default state for a mirror source for a given **mirror-dest** service ID is **no shutdown**. A **shutdown** command is required to disable mirroring from that mirror-source.

## Mirror Destination Configuration Commands

### far-end

|                    |                                                                                                                                                                                                                                                                                                                                                                                                                                                                                                                                                                                                                                                                                                                                                                                                                                                                                                                                                                                                                                                                                                                                                                                                                                                                                                                                                                   |
|--------------------|-------------------------------------------------------------------------------------------------------------------------------------------------------------------------------------------------------------------------------------------------------------------------------------------------------------------------------------------------------------------------------------------------------------------------------------------------------------------------------------------------------------------------------------------------------------------------------------------------------------------------------------------------------------------------------------------------------------------------------------------------------------------------------------------------------------------------------------------------------------------------------------------------------------------------------------------------------------------------------------------------------------------------------------------------------------------------------------------------------------------------------------------------------------------------------------------------------------------------------------------------------------------------------------------------------------------------------------------------------------------|
| <b>Syntax</b>      | <b>far-end</b> <i>ip-address</i> [ <b>ing-svc-label</b> <i>ing-vc-label</i>   <b>tldp</b> ]<br><b>no far-end</b> <i>ip-addr</i>                                                                                                                                                                                                                                                                                                                                                                                                                                                                                                                                                                                                                                                                                                                                                                                                                                                                                                                                                                                                                                                                                                                                                                                                                                   |
| <b>Context</b>     | config>mirror>mirror-dest>remote-source                                                                                                                                                                                                                                                                                                                                                                                                                                                                                                                                                                                                                                                                                                                                                                                                                                                                                                                                                                                                                                                                                                                                                                                                                                                                                                                           |
| <b>Description</b> | <p>This command defines the remote device and configures parameters for mirror destination services on other devices allowed to mirror to the mirror destination service ID.</p> <p>The <b>far-end</b> command is used within the context of the <b>remote-source</b> node. It allows the definition of accepted remote sources for mirrored packets to this <i>mirror-dest-service-id</i>. Up to 50 <b>far-end</b> sources can be specified. If a far end router has not been specified, packets sent to the router are discarded.</p> <p>The <b>far-end</b> command is used to define a remote source 7750 SR that may send mirrored packets to this 7750 SR for handling by this <b>mirror-dest</b> <i>service-id</i>.</p> <p>The <b>ing-svc-label</b> keyword must be given to manually define the expected ingress service label. This ingress label must also be manually defined on the far end address through the <b>mirror-dest</b> SDP binding keyword <b>egr-svc-label</b>.</p> <p>The <b>no</b> form of the command deletes a far end address from the allowed remote senders to this <b>mirror-dest</b> service. All <b>far-end</b> addresses are removed when <b>no remote-source</b> is executed. All signaled ingress service labels are withdrawn from the far end address affected. All manually defined <i>ing-svc-label</i> are removed.</p> |
| <b>Default</b>     | No far end service ingress addresses are defined.                                                                                                                                                                                                                                                                                                                                                                                                                                                                                                                                                                                                                                                                                                                                                                                                                                                                                                                                                                                                                                                                                                                                                                                                                                                                                                                 |
| <b>Parameters</b>  | <p><i>ip-address</i> — The service IP address (system IP address) of the remote device sending mirrored traffic to this mirror destination service. If 0.0.0.0 is specified, any remote is allowed to send to this service.</p> <p><b>Values</b>     1.0.0.1 — 223.255.255.254</p> <p>The ingress service label must be manually defined using the <b>ing-svc-label</b> keyword. On the far end 7750 SR, the associated SDP <b>egr-svc-label</b> must be manually set and equal to the label defined in <b>ing-svc-label</b>.</p> <p><b>ing-svc-label</b> <i>ing-vc-label</i> — Specifies the ingress service label for mirrored service traffic on the <b>far end</b> device for manually configured mirror service labels.</p> <p>The defined <i>ing-svc-label</i> is entered into the ingress service label table which causes ingress packet with that service label to be handled by this <b>mirror-dest</b> service.</p> <p>The specified <i>ing-svc-label</i> must not have been used for any other service ID and must match the far end expected specific <i>egr-svc-label</i> for this 7750 SR. It must be within the range specified for manually configured service labels defined on this 7750 SR. It may be reused for other far end addresses on this <i>mirror-dest-service-id</i>.</p> <p><b>Values</b>     2048 — 18431</p>                     |

**tldp** — Specifies that the label is obtained through signaling via the LDP.

### enable-port-id

|                    |                                                                                                                                                       |
|--------------------|-------------------------------------------------------------------------------------------------------------------------------------------------------|
| <b>Syntax</b>      | <b>[no] enable-port-id</b>                                                                                                                            |
| <b>Context</b>     | configure>mirror>mirror-dest                                                                                                                          |
| <b>Description</b> | This command includes the mirrored packet system's port-id. The system port ID can be used to identify which port the packet was received or sent on. |
| <b>Default</b>     | no enable-port-id                                                                                                                                     |

### endpoint

|                    |                                                                                                                                                                                                                                                                                                                                                                                                                                                                                                                                                                                                                                                                                                                                                                                                                                                                                                                                                                                                                                                                                                                                                                                                                                                                                                                                                                                                                                                                                                                                                                                                                                                                                                    |
|--------------------|----------------------------------------------------------------------------------------------------------------------------------------------------------------------------------------------------------------------------------------------------------------------------------------------------------------------------------------------------------------------------------------------------------------------------------------------------------------------------------------------------------------------------------------------------------------------------------------------------------------------------------------------------------------------------------------------------------------------------------------------------------------------------------------------------------------------------------------------------------------------------------------------------------------------------------------------------------------------------------------------------------------------------------------------------------------------------------------------------------------------------------------------------------------------------------------------------------------------------------------------------------------------------------------------------------------------------------------------------------------------------------------------------------------------------------------------------------------------------------------------------------------------------------------------------------------------------------------------------------------------------------------------------------------------------------------------------|
| <b>Syntax</b>      | <b>endpoint <i>endpoint-name</i> [create]</b><br><b>no endpoint <i>endpoint-name</i></b>                                                                                                                                                                                                                                                                                                                                                                                                                                                                                                                                                                                                                                                                                                                                                                                                                                                                                                                                                                                                                                                                                                                                                                                                                                                                                                                                                                                                                                                                                                                                                                                                           |
| <b>Context</b>     | configure>mirror>mirror-dest<br>configure>mirror>mirror-dest>sap<br>configure>mirror>mirror-dest>sdp                                                                                                                                                                                                                                                                                                                                                                                                                                                                                                                                                                                                                                                                                                                                                                                                                                                                                                                                                                                                                                                                                                                                                                                                                                                                                                                                                                                                                                                                                                                                                                                               |
| <b>Description</b> | <p>A mirror service supports two implicit endpoints managed internally by the system. The following applies to endpoint configurations.</p> <p>Up to two (2) named endpoints may be created per service mirror/LI service. The endpoint name is locally significant to the service mirror/LI service.</p> <ul style="list-style-type: none"><li>• Objects (SAPs or sdp's) may be created on the service mirror/LI with the following limitations:<ul style="list-style-type: none"><li>– two implicit endpoint objects (without explicit endpoints defined)</li><li>– one implicit and multiple explicit object with the same endpoint name</li><li>– multiple explicit objects each with one of two explicit endpoint names</li></ul></li><li>• All objects become associated implicitly or indirectly with the implicit endpoints 'x' and 'y'.</li><li>• Objects may be created without an explicit endpoint defined.</li><li>• Objects may be created with an explicit endpoint defined.</li><li>• Objects without an explicit endpoint may have an explicit endpoint defined without deleting the object.</li><li>• Objects with an explicit endpoint defined may be dynamically moved to another explicit endpoint or may have the explicit endpoint removed.</li></ul> <p>Creating an object without an explicit endpoint:</p> <ul style="list-style-type: none"><li>• If an object on a mirror/LI service has no explicit endpoint name associated, the system attempts to associate the object with implicit endpoint 'x' or 'y'.</li><li>• The implicit endpoint cannot have an existing object association.</li><li>• If both 'x' and 'y' are available, 'x' will be selected.</li></ul> |

- If an 'x' or 'y' association cannot be created, the object cannot be created.

Creating an object with an explicit endpoint name:

- The endpoint name must exist on the mirror/LI service.
- If this is the first object associated with the endpoint name:
  - the object is associated with either implicit endpoint 'x' or 'y'
  - the implicit endpoint cannot have an existing object associated
  - if both 'x' and 'y' are available, 'x' will be selected
  - if 'x' or 'y' is not available, the object cannot be created
  - the implicit endpoint is now associated with the named endpoint
- if this is not the first object associated with the endpoint name:
  - the object is associated with the named endpoint's implicit association

Changing an objects implicit endpoint to an explicit endpoint name

- If the explicit endpoint name is associated with an implicit endpoint, the object is moved to that implicit endpoint
- If the object is the first to be associated with the explicit endpoint name:
  - the object is associated with either implicit endpoint 'x' or 'y'
  - the implicit endpoint cannot have an existing object associated (except this one)
  - if both 'x' and 'y' are available, 'x' will be selected
  - if 'x' or 'y' is not available, the object cannot be moved to the explicit endpoint
  - if moved, the implicit endpoint is now associated with the named endpoint

Changing an objects explicit endpoint to another explicit endpoint name

- If the new explicit endpoint name is associated with an implicit endpoint, the object is moved to that implicit endpoint
- If the object is the first to be associated with the new explicit endpoint name:
  - the object is associated with either implicit endpoint 'x' or 'y'
  - the implicit endpoint cannot have an existing object associated (except this one)
  - if both 'x' and 'y' are available, 'x' will be selected
  - if 'x' or 'y' is not available, the object cannot be moved to the new endpoint
  - if moved, the implicit endpoint is now associated with the named endpoint

An explicitly named endpoint can have a maximum of one SAP and one ICB. Once a SAP is added to the endpoint, only one more object of type ICB sdp is allowed. The ICB sdp cannot be added to the endpoint if the SAP is not part of a MC-LAG instance. Conversely, a SAP which is not part of a MC-LAG instance cannot be added to an endpoint which already has an ICB sdp.

An explicitly named endpoint which does not have a SAP object can have a maximum of four SDPs which can include any of the following: a single primary SDP, one or many secondary SDPs with precedence, and a single ICB SDP.

The user can only add a SAP configured on a MC-LAG instance to this endpoint. Conversely, the user will not be able to change the mirror service type away from mirror service without first deleting the MC-LAG SAP.

The **no** form of the command removes the association of a SAP or a sdp with an explicit endpoint name. Removing an objects explicit endpoint association:

- The system attempts to associate the object with implicit endpoint 'x' or 'y'.
- The implicit endpoint cannot have an existing object association (except this one).
- If both 'x' and 'y' are available, 'x' will be selected.
- If an 'x' or 'y' association cannot be created, the explicit endpoint cannot be removed.

**Parameters** *endpoint-name* — Specifies the endpoint name.  
**create** — Mandatory keyword to create this entry.

## revert-time

**Syntax** **revert-time** {*revert-time* | **infinite**}  
**no revert-time**

**Context** configure>mirror>mirror-dest>endpoint

**Description** This command has an effect only when used in conjunction with a endpoint which contains a SDP of type 'primary'. It is ignored and has no effect in all other cases. The revert-timer is the delay in seconds the system waits before it switches the path of the mirror service from an active secondary SDP in the endpoint into the endpoint primary SDP after the latter comes back up.  
The **no** form of the command resets the timer to the default value of 0. This means that the mirror-service path will be switched back to the endpoint primary sdp immediately after it comes back up.

**Default** 0 — The VLL path will be switched back to the endpoint primary SDP immediately after it comes back up.

**Parameters** *revert-time* — Specifies a delay, in seconds, the system waits before it switches the path of the mirror service from an active secondary SDP in the endpoint into the endpoint primary SDP after the latter comes back up.

**Values** 0 — 600

**infinite** — Forces the mirror/LI service path to never revert to the primary SDP as long as the currently active secondary -SDP is UP.

## fc

|                    |                                                                                                                                                                                                                                                                                                                                                                                                                                                                                                                                                                                                                                                                                                                                                                                                                                                                            |
|--------------------|----------------------------------------------------------------------------------------------------------------------------------------------------------------------------------------------------------------------------------------------------------------------------------------------------------------------------------------------------------------------------------------------------------------------------------------------------------------------------------------------------------------------------------------------------------------------------------------------------------------------------------------------------------------------------------------------------------------------------------------------------------------------------------------------------------------------------------------------------------------------------|
| <b>Syntax</b>      | <b>fc</b> <i>fc-name</i><br><b>no fc</b>                                                                                                                                                                                                                                                                                                                                                                                                                                                                                                                                                                                                                                                                                                                                                                                                                                   |
| <b>Context</b>     | config>mirror>mirror-dest                                                                                                                                                                                                                                                                                                                                                                                                                                                                                                                                                                                                                                                                                                                                                                                                                                                  |
| <b>Description</b> | <p>This command specifies a forwarding class for all mirrored packets transmitted to the destination SAP or SDP overriding the default (be) forwarding class. All packets are sent with the same class of service to minimize out of sequence issues. The mirrored packet does not inherit the forwarding class of the original packet.</p> <p>When the destination is on a SAP, a single egress queue is created that pulls buffers from the buffer pool associated with the <i>fc-name</i>.</p> <p>When the destination is on an SDP, the <i>fc-name</i> defines the DiffServ based egress queue that will be used to reach the destination. The <i>fc-name</i> also defines the encoded forwarding class of the encapsulation.</p> <p>The <b>no</b> form of the command reverts the <b>mirror-dest</b> service ID forwarding class to the default forwarding class.</p> |
| <b>Default</b>     | The best effort (be) forwarding class is associated with the <b>mirror-dest</b> service ID.                                                                                                                                                                                                                                                                                                                                                                                                                                                                                                                                                                                                                                                                                                                                                                                |
| <b>Parameters</b>  | <p><i>fc-name</i> — The name of the forwarding class with which to associate mirrored service traffic. The forwarding class name must already be defined within the system. If the <i>fc-name</i> does not exist, an error will be returned and the <b>fc</b> command will have no effect. If the <i>fc-name</i> does exist, the forwarding class associated with <i>fc-name</i> will override the default forwarding class.</p> <p><b>Values</b>      be, l2, af, l1, h2, ef, h1, nc</p>                                                                                                                                                                                                                                                                                                                                                                                  |

## mirror-dest

|                    |                                                                                                                                                                                                                                                                                                                                                                                                                                                                                                                                                                                                                                                                                                                                                                                                                                                                                                                                                                                                                                                                                                                                                                                                                         |
|--------------------|-------------------------------------------------------------------------------------------------------------------------------------------------------------------------------------------------------------------------------------------------------------------------------------------------------------------------------------------------------------------------------------------------------------------------------------------------------------------------------------------------------------------------------------------------------------------------------------------------------------------------------------------------------------------------------------------------------------------------------------------------------------------------------------------------------------------------------------------------------------------------------------------------------------------------------------------------------------------------------------------------------------------------------------------------------------------------------------------------------------------------------------------------------------------------------------------------------------------------|
| <b>Syntax</b>      | <b>mirror-dest</b> <i>service-id</i> [ <b>type</b> <i>encap-type</i> ]<br><b>no mirror-dest</b>                                                                                                                                                                                                                                                                                                                                                                                                                                                                                                                                                                                                                                                                                                                                                                                                                                                                                                                                                                                                                                                                                                                         |
| <b>Context</b>     | config>mirror                                                                                                                                                                                                                                                                                                                                                                                                                                                                                                                                                                                                                                                                                                                                                                                                                                                                                                                                                                                                                                                                                                                                                                                                           |
| <b>Description</b> | <p>This command creates a context to set up a service that is intended for packet mirroring. It is configured as a service to allow mirrored packets to be directed locally (within the same 7750 SR router) or remotely, over the core of the network and have a far end 7750 SR decode the mirror encapsulation.</p> <p>The <b>mirror-dest</b> service is comprised of destination parameters that define where the mirrored packets are to be sent. It also specifies whether the defined <i>service-id</i> will receive mirrored packets from far end 7750 SR over the network core.</p> <p>The <b>mirror-dest</b> service IDs are persistent between boots of the router and are included in the configuration saves. The local sources of mirrored packets for the service ID are defined within the <b>debug mirror mirror-source</b> command that references the same <i>service-id</i>. Up to 255 <b>mirror-dest</b> service IDs can be created within a single system.</p> <p>The <b>mirror-dest</b> command is used to create or edit a service ID for mirroring purposes. If the <i>service-id</i> does not exist within the context of all defined services, the <b>mirror-dest</b> service is created</p> |

and the context of the CLI is changed to that service ID. If the *service-id* exists within the context of defined **mirror-dest** services, the CLI context is changed for editing parameters on that service ID. If the *service-id* exists within the context of another service type, an error message is returned and CLI context is not changed from the current context.

LI source configuration is saved using the **li>save** command.

The **no** form of the command removes a mirror destination from the system. The **mirror-source** or **li-source** associations with the **mirror-dest** *service-id* do not need to be removed or shutdown first. The **mirror-dest** *service-id* must be shutdown before the service ID can be removed. When the service ID is removed, all **mirror-source** or **li-source** commands that have the service ID defined will also be removed from the system.

**Default** No packet mirroring services are defined.

**Parameters** *service-id* — The service identification identifies the service in the service domain. This ID is unique to this service and cannot be used by any other service, regardless of service type. The same service ID must be configured on every 7750 SR router that this particular service is defined on.

If particular a service ID already exists for a service, then the same value cannot be used to create a mirror destination service ID with the same value. For example:

If an Epipe service-ID **11** exists, then a mirror destination service-ID **11** cannot be created. If a VPLS service-ID **12** exists, then a mirror destination service-ID **12** cannot be created.

If an IES service-ID **13** exists, then a mirror destination service-ID **13** cannot be created.

**Values**     *service-id:*        1 — 2147483647  
              *svc-name:*        64 characters maximum

**type** *encap-type* — The type describes the encapsulation supported by the mirror service.

**Values**     ether, frame-relay, ppp, ip-only, atm-sdu, satop-e1, satop-t1, cesopsn, cesopsn-cas

## remote-source

**Syntax**     [no] **remote-source**

**Context**    config>mirror>mirror-dest

**Description** This command configures remote devices to mirror traffic to this device for mirror service egress. Optionally, deletes all previously defined remote mirror ingress devices.

The remote-source context allows the creation of a ‘sniffer farm’ to consolidate expensive packet capture and diagnostic tools to a central location. Remote areas of the access network can be monitored via normal service provisioning techniques.

Specific far-end routers can be specified with the **far-end** command allowing them to use this router as the destination for the same *mirror-dest-service-id*.

The **remote-source** node allows the source of mirrored packets to be on remote 7750 SR devices. The local 7750 SR will configure its network ports to forward packets associated with the *service-id* to the destination SAP. When **remote-source far-end** addresses are configured, an SDP is not allowed as a destination.

By default, the **remote-source** context contains no **far-end** addresses. When no **far-end** addresses have been specified, network remote devices will not be allowed to mirror packets to the local 7750 SR as a mirror destination. Packets received from unspecified **far-end** addresses will be discarded at network ingress.

The **no** form of the command restores the *service-id* to the default condition to not allow a remote 7750 SR access to the mirror destination. The **far-end** addresses are removed without warning.

**Default** No remote source devices defined

## sap

**Syntax** **sap** *sap-id* [**create**] [**no-endpoint**]  
**sap** *sap-id* [**create**] **endpoint** *name*  
**no sap**

**Context** config>mirror>mirror-dest

**Description** This command creates a service access point (SAP) within a mirror destination service. It also associates a predefined SAP within another service ID to a mirror source.

The SAP is defined with port and encapsulation parameters to uniquely identify the (mirror) SAP on the interface and within the box. The specified SAP may be defined on a FastE, or XGigE, or XGigE access port with a dot1q, null, or q-in-q encapsulation type.

The SAP is owned by the mirror destination service ID. If the interface is administratively down, all SAPs on that interface are also operationally down. A SAP can only be defined on a port configured as an access port with the **mode** command at the interface level.

Only one SAP can be created within a **mirror-dest** service ID. If the defined SAP has not been created on any service within the system, the SAP is created and the context of the CLI will change to the newly created SAP. In addition, the port cannot be a member of a multi-link bundle, LAG, APS group or IMA bundle.

If the defined SAP exists in the context of the service ID of the **mirror-dest** service, the CLI context is changed to the predefined SAP.

If the defined SAP exists in the context of another service ID, **mirror-dest** or any other type, an error is generated and the CLI context is not changed from the current context.

Mirror destination SAPs can be created on Ethernet interfaces that have been defined as an access interface. If the interface is defined as network, the SAP creation returns an error and the current CLI context is not changed.

When the **no** form of this command is used on a SAP created by a mirror destination service ID, the SAP with the specified port and encapsulation parameters is deleted.

**Default** No default SAP for the mirror destination service defined.

**Parameters** *sap-id* — Specifies the physical port identifier portion of the SAP definition. See [Common CLI Command Descriptions on page 327](#) for command syntax.

**endpoint** *name* — specifies the name of the endpoint associated with the SAP.

**no endpoint** — Removes the association of a SAP or a sdp with an explicit endpoint name.

**cem**

**Syntax**  
**Syntax** **cem**

**Context** config>mirror>mirror-dest>sap

**Description** This command enables the context to specify circuit emulation (CEM) mirroring properties. Ingress and egress options cannot be supported at the same time on a CEM encap-type SAP. The options must be configured in either the ingress **or** egress contexts.

**packet**

**Syntax** **packet jitter-buffer milliseconds [payload-size bytes]**  
**packet payload-size bytes**  
**no packet bytes**

**Context** config>mirror>mirror-dest>sap>cem

**Description** This command specifies the jitter buffer size, in milliseconds, and payload size, in bytes.

**Default** The default value depends on the CEM SAP endpoint type, and if applicable, the number of timeslots:

| Endpoint Type     | Timeslots | Default Jitter Buffer (in ms) |
|-------------------|-----------|-------------------------------|
| unstructuredE1    | n/a       | 5                             |
| unstructuredT1    | n/a       | 5                             |
| unstructuredE3    | n/a       | 5                             |
| unstructuredT3    | n/a       | 5                             |
| nxDS0 (E1/T1)     | N = 1     | 32                            |
|                   | N = 2..4  | 16                            |
|                   | N = 5..15 | 8                             |
|                   | N >= 16   | 5                             |
| nxDS0WithCas (E1) | N         | 8                             |
| nxDS0WithCas (T1) | N         | 12                            |

**Parameters** *milliseconds* — specifies the jitter buffer size in milliseconds (ms).  
 Configuring the payload size and jitter buffer to values that result in less than 2 packet buffers or greater than 32 packet buffers is not allowed.

Setting the jitter buffer value to 0 sets it back to the default value.

**Values** 1 — 250

**payload-size bytes** — Specifies the payload size (in bytes) of packets transmitted to the packet service network (PSN) by the CEM SAP. This determines the size of the data that will be transmitted over the service. If the size of the data received is not consistent with the payload size then the packet is considered malformed.

**Default** The default value depends on the CEM SAP endpoint type, and if applicable, the number of timeslots:

| Endpoint Type     | Timeslots | Default Payload Size (in bytes) |
|-------------------|-----------|---------------------------------|
| unstructuredE1    | n/a       | 256                             |
| unstructuredT1    | n/a       | 192                             |
| unstructuredE3    | n/a       | 1024                            |
| unstructuredT3    | n/a       | 1024                            |
| nxDS0 (E1/T1)     | N = 1     | 64                              |
|                   | N = 2..4  | N x 32                          |
|                   | N = 5..15 | N x 16                          |
|                   | N >= 16   | N x 8                           |
| nxDS0WithCas (E1) | N         | N x 16                          |
| nxDS0WithCas (T1) | N         | N x 24                          |

For all endpoint types except for nxDS0WithCas, the valid payload size range is from the default to 2048 bytes.

For nxDS0WithCas, the payload size divide by the number of timeslots must be an integer factor of the number of frames per trunk multiframe (for example, 16 for E1 trunk and 24 for T1 trunk).

For 1xDS0, the payload size must be a multiple of 2.

For NxDS0, where  $N > 1$ , the payload size must be a multiple of the number of timeslots.

For unstructuredE1, unstructuredT1, unstructuredE3 and unstructuredT3, the payload size must be a multiple of 32 bytes.

Configuring the payload size and jitter buffer to values that result in less than 2 packet buffers or greater than 32 packet buffer is not allowed.

Setting the payload size to 0 sets it back to the default value.

**Values** 0, 16 — 2048

### rtp-header

|                    |                                                                                                                                       |
|--------------------|---------------------------------------------------------------------------------------------------------------------------------------|
| <b>Syntax</b>      | <b>[no] rtp-header</b>                                                                                                                |
| <b>Context</b>     | config>mirror>mirror-dest>sap>cem                                                                                                     |
| <b>Description</b> | This command specifies whether an RTP header is used when packets are transmitted to the packet service network (PSN) by the CEM SAP. |
| <b>Default</b>     | no rtp-header                                                                                                                         |

### egress

|                    |                                                                                                                                                                                                                                              |
|--------------------|----------------------------------------------------------------------------------------------------------------------------------------------------------------------------------------------------------------------------------------------|
| <b>Syntax</b>      | <b>egress</b>                                                                                                                                                                                                                                |
| <b>Context</b>     | config>mirror>mirror-dest>sap                                                                                                                                                                                                                |
| <b>Description</b> | This command enables access to the context to associate an egress SAP Quality of Service (QoS) policy with a mirror destination SAP.<br>If no QoS policy is defined, the system default SAP egress QoS policy is used for egress processing. |

### ip-mirror

|                    |                                                |
|--------------------|------------------------------------------------|
| <b>Syntax</b>      | <b>ip-mirror</b>                               |
| <b>Context</b>     | config>mirror>mirror-dest>sap>egress           |
| <b>Description</b> | This command configures IP mirror information. |

### sa-mac

|                    |                                                                                                                                                                                                                             |
|--------------------|-----------------------------------------------------------------------------------------------------------------------------------------------------------------------------------------------------------------------------|
| <b>Syntax</b>      | <b>sa-mac <i>ieee-address</i> da-mac <i>ieee-address</i></b><br><b>no sa-mac</b>                                                                                                                                            |
| <b>Context</b>     | config>mirror>mirror-dest>sap>egress>ip-mirror                                                                                                                                                                              |
| <b>Description</b> | This command configures the source and destination MAC addresses for IP mirroring.                                                                                                                                          |
| <b>Parameters</b>  | <b>sa-mac <i>ieee-address</i></b> — Specifies the source MAC address. Multicast, Broadcast and zeros are not allowed.<br><b>da-mac <i>ieee-address</i></b> — Specifies the destination MAC address. Zeroes are not allowed. |

## qos

|                    |                                                                                                                                                                                                                                                                                                                                                 |
|--------------------|-------------------------------------------------------------------------------------------------------------------------------------------------------------------------------------------------------------------------------------------------------------------------------------------------------------------------------------------------|
| <b>Syntax</b>      | <b>qos</b> <i>policy-id</i><br><b>no qos</b>                                                                                                                                                                                                                                                                                                    |
| <b>Context</b>     | config>mirror>mirror-dest>sap>egress                                                                                                                                                                                                                                                                                                            |
| <b>Description</b> | <p>This command associates a QoS policy with an egress SAP for a mirrored service.</p> <p>By default, no specific QoS policy is associated with the SAP for egress, so the default QoS policy is used.</p> <p>The <b>no</b> form of the command removes the QoS policy association from the SAP, and the QoS policy reverts to the default.</p> |
| <b>Default</b>     | QoS policy-id 1.                                                                                                                                                                                                                                                                                                                                |
| <b>Parameters</b>  | <i>policy-id</i> — The QoS policy ID to associate with SAP for the mirrored service. The policy ID must already exist.                                                                                                                                                                                                                          |
| <b>Values</b>      | 1 — 65535                                                                                                                                                                                                                                                                                                                                       |

## slice-size

|                    |                                                                                                                                                                                                                                                                                                                                                                                                                                                                                                                                                                                                                                                                                                                                                                                                                                                                                                                                                                                                                                                                                                                                                                                                                                                                                                                                                                                                                                                                                                                                                                                                                                                                                                  |
|--------------------|--------------------------------------------------------------------------------------------------------------------------------------------------------------------------------------------------------------------------------------------------------------------------------------------------------------------------------------------------------------------------------------------------------------------------------------------------------------------------------------------------------------------------------------------------------------------------------------------------------------------------------------------------------------------------------------------------------------------------------------------------------------------------------------------------------------------------------------------------------------------------------------------------------------------------------------------------------------------------------------------------------------------------------------------------------------------------------------------------------------------------------------------------------------------------------------------------------------------------------------------------------------------------------------------------------------------------------------------------------------------------------------------------------------------------------------------------------------------------------------------------------------------------------------------------------------------------------------------------------------------------------------------------------------------------------------------------|
| <b>Syntax</b>      | <b>slice-size</b> <i>bytes</i><br><b>no slice-size</b>                                                                                                                                                                                                                                                                                                                                                                                                                                                                                                                                                                                                                                                                                                                                                                                                                                                                                                                                                                                                                                                                                                                                                                                                                                                                                                                                                                                                                                                                                                                                                                                                                                           |
| <b>Context</b>     | config>mirror>mirror-dest                                                                                                                                                                                                                                                                                                                                                                                                                                                                                                                                                                                                                                                                                                                                                                                                                                                                                                                                                                                                                                                                                                                                                                                                                                                                                                                                                                                                                                                                                                                                                                                                                                                                        |
| <b>Description</b> | <p>This command enables mirrored frame truncation and specifies the maximum size, in bytes, of a mirrored frame that can be transmitted to the mirror destination.</p> <p>This command enables mirroring larger frames than the destination packet decode equipment can handle. It also allows conservation of mirroring resources by limiting the size of the packet stream through the router and the core network.</p> <p>When defined, the mirror <b>slice-size</b> creates a threshold that truncates a mirrored frame to a specific size. For example, if the value of 256 bytes is defined, a frame larger than 256 bytes will only have the first 256 bytes transmitted to the mirror destination. The original frame is not affected by the truncation. The mirrored frame size may increase if encapsulation information is added during transmission through the network core or out the mirror destination SAP to the packet/protocol decode equipment.</p> <p>The actual capability of the router to transmit a sliced or non-sliced frame is also dictated by the mirror destination SDP <b>path-mtu</b> and/or the mirror destination SAP physical MTU. Packets that require a larger MTU than the mirroring destination supports are discarded if the defined <b>slice-size</b> does not truncate the packet to an acceptable size.</p> <p><b>Notes:</b></p> <ul style="list-style-type: none"> <li>• When configuring IP mirroring, packet slice will be rejected as an incorrect option as it will cause IP packets to be rejected by the next hop with an IP header verification error.</li> <li>• Slice-size is not supported by CEM encap-types or IP-mirroring.</li> </ul> |

## Configuration Commands

The **no** form of the command disables mirrored packet truncation.

**Default** **no slice-size** — Mirrored packet truncation is disabled.

**Parameters** *bytes* — The number of bytes to which mirrored frames will be truncated, expressed as a decimal integer.

**Values** 128 — 9216

## spoke-sdp

**Syntax** **spoke-sdp** *sdp-id:vc-id* [**create**] [**no-endpoint**]  
**spoke-sdp** *sdp-id:vc-id* [**create**] **endpoint** *name* [**icb**]  
**no sdp** *sdp-id:vc-id*

**Context** config>mirror>mirror-dest

**Description** This command binds an existing (mirror) service distribution path (SDP) to the mirror destination service ID.

The operational state of the SDP dictates the operational state of the SDP binding to the mirror destination. If the SDP is shutdown or operationally down, then SDP binding is down. Once the binding is defined and the service and SDP are operational, the far-end router defined in the **config service sdp sdp-id far-end** parameter is considered part of the service ID.

Only one SDP can be associated with a mirror destination service ID. If a second **sdp** command is executed after a successful SDP binding, an error occurs and the command has no effect on the existing configuration. A **no sdp** command must be issued before a new SDP binding can be attempted.

An SDP is a logical mechanism that ties a far end router to a specific service without having to define the far-end SAP. Each SDP represents a method to reach a router.

One method is the IP Generic Router Encapsulation (GRE) encapsulation, which has no state in the core of the network. GRE does not specify a specific path to a router. A GRE-based SDP uses the underlying IGP routing table to find the best next hop to the far end router.

The other method is Multi-Protocol Label Switching (MPLS) encapsulation. router routers support both signaled and non-signaled LSPs (Label Switched Path) though the network. Non-signaled paths are defined at each hop through the network. Signaled paths are protocol communicated from end to end using RSVP. Paths may be manually defined or a constraint based routing protocol (i.e., OSPF-TE or CSPF) can be used to determine the best path with specific constraints.

SDPs are created and then bound to services. Many services can be bound to a single SDP. The operational and administrative state of the SDP controls the state of the SDP binding to the service.

An egress service label (Martini VC-Label), used by the SDP to differentiate each service bound to the SDP to the far-end router, must be obtained manually or through signaling with the far end. If manually configured, it must match the **ing-svc-label** defined for the local router.

The **no** form of the command removes the SDP binding from the mirror destination service. Once removed, no packets are forwarded to the far-end (destination) router from that mirror destination service ID.

**Default** No default SDP ID is bound to a mirror destination service ID. If no SDP is bound to the service, the mirror destination will be local and cannot be to another router over the core network.

**Parameters** *sdp-id[:vc-id]* — A locally unique SDP identification (ID) number. The SDP ID must exist. If the SDP ID does not exist, an error will occur and the command will not execute.

For mirror services, the *vc-id* defaults to the *service-id*. However, there are scenarios where the *vc-id* is being used by another service. In this case, the SDP binding cannot be created. So, to avoid this, the mirror service SDP bindings now accepts *vc-ids*.

**Values** 1 — 17407

**endpoint name** — specifies the name of the endpoint associated with the SAP.

**no endpoint** — Removes the association of a SAP or a SDP with an explicit endpoint name.

**icb** — Indicates that the SDP is of type Inter-Chassis Backup (ICB). This is a special pseudowire used for MC-LAG and pseudowire redundancy application.

An explicitly named endpoint can have a maximum of one SAP and one ICB. Once a SAP is added to the endpoint, only one more object of type ICB SDP is allowed. The ICB SDP cannot be added to the endpoint if the SAP is not part of a MC-LAG instance. This means that all other SAP types cannot exist on the same endpoint as an ICB SDP since non Ethernet SAP cannot be part of a MC-LAG instance. Conversely, a SAP which is not part of a MC-LAG instance cannot be added to an endpoint which already has an ICB SDP.

An explicitly named endpoint, which does not have a SAP object, can have a maximum of four SDPs, which can include any of the following: a single primary SDP, one or many secondary SDPs with precedence, and a single ICB SDP.

**Default** Null. The user should explicitly configure this option at create time. The user can remove the ICB type simply by retyping the SDP configuration without the *icb* keyword.

## egress

**Syntax** **egress**

**Context** config>mirror>mirror-dest>spoke-sdp

**Description** This command enters the context to configure spoke SDP egress parameters.

## vc-label

**Syntax** **vc-label egress-vc-label**  
**no vc-label [egress-vc-label]**

**Context** config>mirror>mirror-dest>spoke-sdp>egress

**Description** This command configures the spoke-SDP egress VC label.

**Parameters** *egress-vc-label* — A VC egress value that indicates a specific connection.

**Values** 16 — 1048575

## precedence

**precedence** *precedence-value* | **primary**  
**no precedence**

**Context** config>mirror>mirror-dest>spoke-sdp>egress

**Description** This command indicates that the SDP is of type secondary with a specific precedence value or of type primary.

The mirror/LI service always uses the primary type as the active pseudowire and only switches to a secondary pseudowire when the primary is down. The mirror service switches the path back to the primary pseudowire when it is back up. The user can configure a timer to delay reverting back to primary or to never revert back.

If the active pseudowire goes down, the mirror service switches the path to a secondary sdp with the lowest precedence value. That is, secondary SDPs which are operationally up are considered in the order of their precedence value, 1 being the lowest value and 4 being the highest value. If the precedence value is the same, then the SDP with the lowest sdp ID is selected.

An explicitly named endpoint can have a maximum of one SAP and one ICB. Once a SAP is added to the endpoint, only one more object of type ICB SDP is allowed. An explicitly named endpoint, which does not have a SAP object, can have a maximum of four SDPs, which can include any of the following: a single primary SDP, one or many secondary SDPs with precedence, and a single ICB SDP.

**Context** An SDP is created with type secondary and with the lowest precedence value of 4.

**Parameters** *prec-value* — The precedence of the SDP.

**Values** 1-4

**primary** — A special value of the precedence which assigns the SDP the lowest precedence and enables the revertive behavior.

---

## Mirror Source Configuration Commands

### mirror-source

|                    |                                                                                                                                                                                                                                                                                                                                                                                                                                                                                                                                                                                                                                                                                                                                                                                                                                                                                                                                                                                                                                                                                                                                                                                                                                                                                                                                                                                                                                                                                                                                                                                                                                                                                                                                                                                                                                                                                                                                                                                                                                                                                                                                                                                                                                                                                                                                                                                                                                                                                                                                                                                                                               |
|--------------------|-------------------------------------------------------------------------------------------------------------------------------------------------------------------------------------------------------------------------------------------------------------------------------------------------------------------------------------------------------------------------------------------------------------------------------------------------------------------------------------------------------------------------------------------------------------------------------------------------------------------------------------------------------------------------------------------------------------------------------------------------------------------------------------------------------------------------------------------------------------------------------------------------------------------------------------------------------------------------------------------------------------------------------------------------------------------------------------------------------------------------------------------------------------------------------------------------------------------------------------------------------------------------------------------------------------------------------------------------------------------------------------------------------------------------------------------------------------------------------------------------------------------------------------------------------------------------------------------------------------------------------------------------------------------------------------------------------------------------------------------------------------------------------------------------------------------------------------------------------------------------------------------------------------------------------------------------------------------------------------------------------------------------------------------------------------------------------------------------------------------------------------------------------------------------------------------------------------------------------------------------------------------------------------------------------------------------------------------------------------------------------------------------------------------------------------------------------------------------------------------------------------------------------------------------------------------------------------------------------------------------------|
| <b>Syntax</b>      | <b>[no] mirror-source</b> <i>service-id</i>                                                                                                                                                                                                                                                                                                                                                                                                                                                                                                                                                                                                                                                                                                                                                                                                                                                                                                                                                                                                                                                                                                                                                                                                                                                                                                                                                                                                                                                                                                                                                                                                                                                                                                                                                                                                                                                                                                                                                                                                                                                                                                                                                                                                                                                                                                                                                                                                                                                                                                                                                                                   |
| <b>Context</b>     | debug                                                                                                                                                                                                                                                                                                                                                                                                                                                                                                                                                                                                                                                                                                                                                                                                                                                                                                                                                                                                                                                                                                                                                                                                                                                                                                                                                                                                                                                                                                                                                                                                                                                                                                                                                                                                                                                                                                                                                                                                                                                                                                                                                                                                                                                                                                                                                                                                                                                                                                                                                                                                                         |
| <b>Description</b> | <p>This command configures mirror source parameters for a mirrored service.</p> <p>The <b>mirror-source</b> command is used to enable mirroring of packets specified by the association of the <b>mirror-source</b> to sources of packets defined within the context of the <i>mirror-dest-service-id</i>. The mirror destination service must already exist within the system.</p> <p>A mirrored packet cannot be mirrored to multiple destinations. If a mirrored packet is properly referenced by multiple mirror sources (for example, a SAP on one <b>mirror-source</b> and a port on another <b>mirror-source</b>), then the packet is mirrored to a single <i>mirror-dest-service-id</i> based on the following hierarchy:</p> <ol style="list-style-type: none"> <li>1. Filter entry</li> <li>2. Subscriber mirror priority</li> <li>3. Service access port (SAP)</li> <li>4. Physical port</li> </ol> <p>The hierarchy is structured so the most specific match criteria has precedence over a less specific match. For example, if a <b>mirror-source</b> defines a port and a SAP on that port, then the SAP mirror-source is accepted and the mirror-source for the port is ignored because of the hierarchical order of precedence.</p> <p>The <b>mirror-source</b> configuration is not saved when a configuration is saved. A <b>mirror-source</b> manually configured within an ASCII configuration file will not be preserved if that file is overwritten by a <b>save</b> command. Define the <b>mirror-source</b> within a file associated with a <b>config exec</b> command to make a <b>mirror-source</b> persistent between system reboots.</p> <p>By default, all <b>mirror-dest</b> service IDs have a <b>mirror-source</b> associated with them. The <b>mirror-source</b> is not technically created with this command. Instead the service ID provides a contextual node for storing the current mirroring sources for the associated <b>mirror-dest</b> service ID. The <b>mirror-source</b> is created for the mirror service when the operator enters the <b>debug&gt;mirror-source</b> <i>svcId</i> for the first time. If the operator enters <b>li&gt;li-source</b> <i>svcId</i> for the first time, an LI source is created for the mirror service. The <b>mirror-source</b> is also automatically removed when the <b>mirror-dest</b> service ID is deleted from the system.</p> <p>The <b>no</b> form of the command deletes all related source commands within the context of the <b>mirror-source</b> <i>service-id</i>. The command does not remove the service ID from the system.</p> |
| <b>Default</b>     | No mirror source match criteria is defined for the mirror destination service.                                                                                                                                                                                                                                                                                                                                                                                                                                                                                                                                                                                                                                                                                                                                                                                                                                                                                                                                                                                                                                                                                                                                                                                                                                                                                                                                                                                                                                                                                                                                                                                                                                                                                                                                                                                                                                                                                                                                                                                                                                                                                                                                                                                                                                                                                                                                                                                                                                                                                                                                                |
| <b>Parameters</b>  | <i>service-id</i> — The mirror destination service ID for which match criteria will be defined. The <i>service-id</i> must already exist within the system.                                                                                                                                                                                                                                                                                                                                                                                                                                                                                                                                                                                                                                                                                                                                                                                                                                                                                                                                                                                                                                                                                                                                                                                                                                                                                                                                                                                                                                                                                                                                                                                                                                                                                                                                                                                                                                                                                                                                                                                                                                                                                                                                                                                                                                                                                                                                                                                                                                                                   |

|               |                    |                       |
|---------------|--------------------|-----------------------|
| <b>Values</b> | <i>service-id:</i> | 1 — 2147483647        |
|               | <i>svc-name:</i>   | 64 characters maximum |

## ip-filter

|                    |                                                                                                                                                                                                                                                                                                                                                                                                                                                                                                                                                                                                                                                                                                                                                                                                                                                                                                                                                                                                                                                                                                                                                                                                                                                                                                                                                                                                                                                                                                                                                                                                                                                                                                                                                                                                                                                                                                                                                                                                                                                                                                                                                                                     |
|--------------------|-------------------------------------------------------------------------------------------------------------------------------------------------------------------------------------------------------------------------------------------------------------------------------------------------------------------------------------------------------------------------------------------------------------------------------------------------------------------------------------------------------------------------------------------------------------------------------------------------------------------------------------------------------------------------------------------------------------------------------------------------------------------------------------------------------------------------------------------------------------------------------------------------------------------------------------------------------------------------------------------------------------------------------------------------------------------------------------------------------------------------------------------------------------------------------------------------------------------------------------------------------------------------------------------------------------------------------------------------------------------------------------------------------------------------------------------------------------------------------------------------------------------------------------------------------------------------------------------------------------------------------------------------------------------------------------------------------------------------------------------------------------------------------------------------------------------------------------------------------------------------------------------------------------------------------------------------------------------------------------------------------------------------------------------------------------------------------------------------------------------------------------------------------------------------------------|
| <b>Syntax</b>      | <p><b>ip-filter</b> <i>ip-filter-id</i> <b>entry</b> <i>entry-id</i> [<i>entry-id</i> ...]</p> <p><b>no ip-filter</b> <i>ip-filter-id</i></p> <p><b>no ip-filter</b> <i>ip-filter-id</i> <b>entry</b> <i>entry-id</i> [<i>entry-id</i> ...]</p>                                                                                                                                                                                                                                                                                                                                                                                                                                                                                                                                                                                                                                                                                                                                                                                                                                                                                                                                                                                                                                                                                                                                                                                                                                                                                                                                                                                                                                                                                                                                                                                                                                                                                                                                                                                                                                                                                                                                     |
| <b>Context</b>     | debug>mirror-source                                                                                                                                                                                                                                                                                                                                                                                                                                                                                                                                                                                                                                                                                                                                                                                                                                                                                                                                                                                                                                                                                                                                                                                                                                                                                                                                                                                                                                                                                                                                                                                                                                                                                                                                                                                                                                                                                                                                                                                                                                                                                                                                                                 |
| <b>Description</b> | <p>This command enables mirroring of packets that match specific entries in an existing IP filter.</p> <p>The <b>ip-filter</b> command directs packets which match the defined list of entry IDs to be mirrored to the mirror destination referenced by the <i>mirror-dest-service-id</i> of the <b>mirror-source</b>.</p> <p>The IP filter must already exist in order for the command to execute. Filters are configured in the <b>conf&gt;filter</b> context. If the IP filter does not exist, an error will occur. If the filter exists but has not been associated with a SAP or IP interface, an error is not generated but mirroring will not be enabled (there are no packets to mirror). Once the IP filter is defined to a SAP or IP interface, mirroring is enabled.</p> <p>If the IP filter is defined as ingress, only ingress packets are mirrored. Ingress mirrored packets are mirrored to the mirror destination prior to any ingress packet modifications.</p> <p>If the IP filter is defined as egress, only egress packets are mirrored. Egress mirrored packets are mirrored to the mirror destination after all egress packet modifications.</p> <p>An <i>entry-id</i> within an IP filter can only be mirrored to a single mirror destination. If the same <i>entry-id</i> is defined multiple times, an error occurs and only the first <b>mirror-source</b> definition is in effect.</p> <p>By default, no packets matching any IP filters are mirrored. Mirroring of IP filter entries must be explicitly defined.</p> <p>The <b>no ip-filter</b> command, without the <b>entry</b> keyword, removes mirroring on all <i>entry-id</i>'s within the <i>ip-filter-id</i>.</p> <p>When the <b>no</b> command is executed with the <b>entry</b> keyword and one or more <i>entry-id</i>'s, mirroring of that list of <i>entry-id</i>'s is terminated within the <i>ip-filter-id</i>. If an <i>entry-id</i> is listed that does not exist, an error will occur and the command will not execute. If an <i>entry-id</i> is listed that is not currently being mirrored, no error will occur for that <i>entry-id</i> and the command will execute normally.</p> |
| <b>Default</b>     | IP filter mirroring is not defined.                                                                                                                                                                                                                                                                                                                                                                                                                                                                                                                                                                                                                                                                                                                                                                                                                                                                                                                                                                                                                                                                                                                                                                                                                                                                                                                                                                                                                                                                                                                                                                                                                                                                                                                                                                                                                                                                                                                                                                                                                                                                                                                                                 |
| <b>Parameters</b>  | <p><i>ip-filter-id</i> — The IP filter ID whose entries are mirrored. If the <i>ip-filter-id</i> does not exist, an error will occur and the command will not execute. Mirroring of packets will commence once the <i>ip-filter-id</i> is defined on a SAP or IP interface.</p> <p><b>entry</b> <i>entry-id</i> [<i>entry-id</i> ...] — The IP filter entries to use as match criteria for packet mirroring. The <b>entry</b> keyword begins a list of <i>entry-id</i>'s for mirroring. Multiple <i>entry-id</i> entries may be specified with a single command. Each <i>entry-id</i> must be separated by a space.</p> <p>If an <i>entry-id</i> does not exist within the IP filter, an error occurs and the command will not execute.</p>                                                                                                                                                                                                                                                                                                                                                                                                                                                                                                                                                                                                                                                                                                                                                                                                                                                                                                                                                                                                                                                                                                                                                                                                                                                                                                                                                                                                                                         |

If the filter's *entry-id* is renumbered within the IP filter definition, the old *entry-id* is removed but the new *entry-id* must be manually added to the configuration to include the new (renumbered) entry's criteria.

## mac-filter

|                    |                                                                                                                                                                                                                                                                                                                                                                                                                                                                                                                                                                                                                                                                                                                                                                                                                                                                                                                                                                                                                                                                                                                                                                                                                                                                                                                                                                                                                                                                                                                                                                                                                                                                                                                                                                                                                                                                                                                                                                                                                                                                                                                                                                                         |
|--------------------|-----------------------------------------------------------------------------------------------------------------------------------------------------------------------------------------------------------------------------------------------------------------------------------------------------------------------------------------------------------------------------------------------------------------------------------------------------------------------------------------------------------------------------------------------------------------------------------------------------------------------------------------------------------------------------------------------------------------------------------------------------------------------------------------------------------------------------------------------------------------------------------------------------------------------------------------------------------------------------------------------------------------------------------------------------------------------------------------------------------------------------------------------------------------------------------------------------------------------------------------------------------------------------------------------------------------------------------------------------------------------------------------------------------------------------------------------------------------------------------------------------------------------------------------------------------------------------------------------------------------------------------------------------------------------------------------------------------------------------------------------------------------------------------------------------------------------------------------------------------------------------------------------------------------------------------------------------------------------------------------------------------------------------------------------------------------------------------------------------------------------------------------------------------------------------------------|
| <b>Syntax</b>      | <p><b>mac-filter</b> <i>mac-filter-id</i> <b>entry</b> <i>entry-id</i> [<i>entry-id</i> ...]</p> <p><b>no mac-filter</b> <i>mac-filter-id</i></p> <p><b>no mac-filter</b> <i>mac-filter-id</i> <b>entry</b> <i>entry-id</i> [<i>entry-id</i> ...]</p>                                                                                                                                                                                                                                                                                                                                                                                                                                                                                                                                                                                                                                                                                                                                                                                                                                                                                                                                                                                                                                                                                                                                                                                                                                                                                                                                                                                                                                                                                                                                                                                                                                                                                                                                                                                                                                                                                                                                   |
| <b>Context</b>     | debug>mirror-source                                                                                                                                                                                                                                                                                                                                                                                                                                                                                                                                                                                                                                                                                                                                                                                                                                                                                                                                                                                                                                                                                                                                                                                                                                                                                                                                                                                                                                                                                                                                                                                                                                                                                                                                                                                                                                                                                                                                                                                                                                                                                                                                                                     |
| <b>Description</b> | <p>This command enables mirroring of packets that match specific entries in an existing MAC filter.</p> <p>The <b>mac-filter</b> command directs packets which match the defined list of entry IDs to be mirrored to the mirror destination referenced by the <i>mirror-dest-service-id</i> of the <b>mirror-source</b>.</p> <p>The MAC filter must already exist in order for the command to execute. Filters are configured in the config&gt;filter context. If the MAC filter does not exist, an error will occur. If the filter exists but has not been associated with a SAP or IP interface, an error is not generated but mirroring will not be enabled (there are no packets to mirror). Once the filter is defined to a SAP or MAC interface, mirroring is enabled.</p> <p>If the MAC filter is defined as ingress, only ingress packets are mirrored. Ingress mirrored packets are mirrored to the mirror destination prior to any ingress packet modifications.</p> <p>If the MAC filter is defined as egress, only egress packets are mirrored. Egress mirrored packets are mirrored to the mirror destination after all egress packet modifications.</p> <p>An <i>entry-id</i> within a MAC filter can only be mirrored to a single mirror destination. If the same <i>entry-id</i> is defined multiple times, an error occurs and only the first <b>mirror-source</b> definition is in effect.</p> <p>By default, no packets matching any MAC filters are mirrored. Mirroring of MAC filter entries must be explicitly defined.</p> <p>The <b>no mac-filter</b> command, without the <b>entry</b> keyword, removes mirroring on all <i>entry-id</i>'s within the <i>mac-filter-id</i>.</p> <p>When the <b>no</b> command is executed with the <b>entry</b> keyword and one or more <i>entry-id</i>'s, mirroring of that list of <i>entry-id</i>'s is terminated within the <i>mac-filter-id</i>. If an <i>entry-id</i> is listed that does not exist, an error will occur and the command will not execute. If an <i>entry-id</i> is listed that is not currently being mirrored, no error will occur for that <i>entry-id</i> and the command will execute normally.</p> |
| <b>Default</b>     | No MAC filter mirroring defined.                                                                                                                                                                                                                                                                                                                                                                                                                                                                                                                                                                                                                                                                                                                                                                                                                                                                                                                                                                                                                                                                                                                                                                                                                                                                                                                                                                                                                                                                                                                                                                                                                                                                                                                                                                                                                                                                                                                                                                                                                                                                                                                                                        |
| <b>Parameters</b>  | <p><i>mac-filter-id</i> — The MAC filter ID whose entries are mirrored. If the <i>mac-filter-id</i> does not exist, an error will occur and the command will not execute. Mirroring of packets will commence once the <i>mac-filter-id</i> is defined on a SAP.</p> <p><b>entry</b> <i>entry-id</i> [<i>entry-id</i> ...] — The MAC filter entries to use as match criteria for packet mirroring. The <b>entry</b> keyword begins a list of <i>entry-id</i>'s for mirroring. Multiple <i>entry-id</i> entries may be specified with a single command. Each <i>entry-id</i> must be separated by a space. Up to 8 entry IDs may be specified in a single command.</p> <p>Each <i>entry-id</i> must exist within the <i>mac-filter-id</i>. If the <i>entry-id</i> is renumbered within the MAC</p>                                                                                                                                                                                                                                                                                                                                                                                                                                                                                                                                                                                                                                                                                                                                                                                                                                                                                                                                                                                                                                                                                                                                                                                                                                                                                                                                                                                        |

filter definition, the old *entry-id* is removed from the list and the new *entry-id* will need to be manually added to the list if mirroring is still desired.

If no *entry-id* entries are specified in the command, mirroring will not occur for that MAC filter ID. The command will have no effect.

### port

|                    |                                                                                                                                                                                                                                                                                                                                                                                                                                                                                                                                                                                                                                                                                                                                                                                                                                                                                                                                                                                                                                                                                                                                                                                                                                                                                                                                                                                                                                                                                                                                                                                                                                                                                                                                                                                                                                                                                                                                                                                                                                                                                                                                                                                                                                                                                                 |
|--------------------|-------------------------------------------------------------------------------------------------------------------------------------------------------------------------------------------------------------------------------------------------------------------------------------------------------------------------------------------------------------------------------------------------------------------------------------------------------------------------------------------------------------------------------------------------------------------------------------------------------------------------------------------------------------------------------------------------------------------------------------------------------------------------------------------------------------------------------------------------------------------------------------------------------------------------------------------------------------------------------------------------------------------------------------------------------------------------------------------------------------------------------------------------------------------------------------------------------------------------------------------------------------------------------------------------------------------------------------------------------------------------------------------------------------------------------------------------------------------------------------------------------------------------------------------------------------------------------------------------------------------------------------------------------------------------------------------------------------------------------------------------------------------------------------------------------------------------------------------------------------------------------------------------------------------------------------------------------------------------------------------------------------------------------------------------------------------------------------------------------------------------------------------------------------------------------------------------------------------------------------------------------------------------------------------------|
| <b>Syntax</b>      | <b>port</b> { <i>port-id</i>   <b>lag</b> <i>lag-id</i> } {[ <b>egress</b> ] [ <b>ingress</b> ]}<br><b>no port</b> { <i>port-id</i>   <b>lag</b> <i>lag-id</i> } [ <b>egress</b> ] [ <b>ingress</b> ]                                                                                                                                                                                                                                                                                                                                                                                                                                                                                                                                                                                                                                                                                                                                                                                                                                                                                                                                                                                                                                                                                                                                                                                                                                                                                                                                                                                                                                                                                                                                                                                                                                                                                                                                                                                                                                                                                                                                                                                                                                                                                           |
| <b>Context</b>     | debug>mirror-source                                                                                                                                                                                                                                                                                                                                                                                                                                                                                                                                                                                                                                                                                                                                                                                                                                                                                                                                                                                                                                                                                                                                                                                                                                                                                                                                                                                                                                                                                                                                                                                                                                                                                                                                                                                                                                                                                                                                                                                                                                                                                                                                                                                                                                                                             |
| <b>Description</b> | <p>This command enables mirroring of traffic ingressing or egressing a port (Ethernet port, SONET/SDH channel, TDM channel, or Link Aggregation Group (LAG)).</p> <p>The <b>port</b> command associates a port or LAG to a mirror source. The port is identified by the <i>port-id</i>. The defined port may be Ethernet, SONET/SDH, access or network, or TDM channel, access. A network port may be a single port or a Link Aggregation Group (LAG) ID. When a LAG ID is given as the <i>port-id</i>, mirroring is enabled on all ports making up the LAG. If the port is a SONET/SDH interface, the <i>channel-id</i> must be specified to identify which channel is being mirrored. Either a LAG port member <i>or</i> the LAG port can be mirrored.</p> <p>The port is only referenced in the mirror source for mirroring purposes. The mirror source association does not need to be removed before deleting the card to which the port belongs. If the port is removed from the system, the mirroring association will be removed from the mirror source.</p> <p>The same port may not be associated with multiple mirror source definitions with the <b>ingress</b> parameter defined. The same port may not be associated with multiple mirror source definitions with the <b>egress</b> parameter defined.</p> <p>If a SAP is mirrored on an access port, the SAP mirroring will have precedence over the access port mirroring when a packet matches the SAP mirroring criteria. Filter and label mirroring destinations will also precedence over a port-mirroring destination.</p> <p>If the port is not associated with a <b>mirror-source</b>, packets on that port will not be mirrored. Mirroring may still be defined for a SAP, label or filter entry, which will mirror based on a more specific criteria.</p> <p>The encapsulation type on an access port or channel cannot be changed to Frame Relay if it is being mirrored.</p> <p>The <b>no port</b> command disables port mirroring for the specified port. Mirroring of packets on the port may continue due to more specific mirror criteria. If the <b>egress</b> or <b>ingress</b> parameter keywords are specified in the <b>no</b> command, only the ingress or egress mirroring condition will be removed.</p> |
| <b>Default</b>     | No ports are defined.                                                                                                                                                                                                                                                                                                                                                                                                                                                                                                                                                                                                                                                                                                                                                                                                                                                                                                                                                                                                                                                                                                                                                                                                                                                                                                                                                                                                                                                                                                                                                                                                                                                                                                                                                                                                                                                                                                                                                                                                                                                                                                                                                                                                                                                                           |
| <b>Parameters</b>  | <p><i>port-id</i> — Specifies the port ID.</p> <p><b>Syntax:</b> port-id: <i>slot/mda/port[.channel]</i><br/>         bundle-id: <i>bundle-type-slot/mda.bundle-num</i><br/>         bundle keyword<br/> <i>type</i> ima, fr, ppp<br/> <i>bundle-num</i> 1 — 336</p>                                                                                                                                                                                                                                                                                                                                                                                                                                                                                                                                                                                                                                                                                                                                                                                                                                                                                                                                                                                                                                                                                                                                                                                                                                                                                                                                                                                                                                                                                                                                                                                                                                                                                                                                                                                                                                                                                                                                                                                                                            |

**bpgrp-id:** *bpgrp-type-bpgrp-num*  
               **bpgrp**          keyword  
               *type*              ima, ppp  
               *bpgrp-num*      1 — 2000  
**aps-id:**      *aps-group-id.channel*  
               **aps**              keyword  
               *group-id*          1 — 64  
**ccag-id:**      *ccag-id.path-id cc-type:cc-id*  
               **ccag**              keyword  
               *id*                  1 — 8  
               *path-id*          a, b  
               *cc-type*          .sap-net, .net-sap  
               *cc-id*              0 — 4094

**ccag-id** *ccag-id.path-id[cc-type]:cc-id*  
           **ccag**      keyword  
           **id**          1 — 8  
           **path-id**      a, b  
           **cc-type**      .sap-net, .net-sap  
           **cc-id**      0 — 4094

*lag-id* — The LAG identifier, expressed as a decimal integer.

**Values**      1 — 200

**egress** — Specifies that packets egressing the port should be mirrored. Egress packets are mirrored to the mirror destination after egress packet modification.

**ingress** — Specifies that packets ingressing the port should be mirrored. Ingress packets are mirrored to the mirror destination prior to ingress packet modification.

## sap

**Syntax**      **sap** *sap-id* {[**egress**] [**ingress**]}  
               **no sap** *sap-id* [**egress**] [**ingress**]

**Context**      debug>mirror-source

**Description** This command enables mirroring of traffic ingressing or egressing a service access port (SAP). A SAP that is defined within a mirror destination cannot be used in a mirror source. The mirror source SAP referenced by the *sap-id* is owned by the service ID of the service in which it was created. The SAP is only referenced in the mirror source name for mirroring purposes. The mirror source association does not need to be removed before deleting the SAP from its service ID. If the SAP is deleted from its service ID, the mirror association is removed from the mirror source.

More than one SAP can be associated within a single **mirror-source**. Each SAP has its own **ingress** and **egress** parameter keywords to define which packets are mirrored to the mirror destination.

The SAP must be valid and properly configured. If the associated SAP does not exist, an error occurs and the command will not execute.

The same SAP cannot be associated with multiple mirror source definitions for ingress packets.  
The same SAP cannot be associated with multiple mirror source definitions for egress packets.

If a particular SAP is not associated with a mirror source name, then that SAP will not have mirroring enabled for that mirror source.

Note that the ingress and egress options cannot be supported at the same time on a CEM encap-type SAP. The options must be configured in either the ingress **or** egress contexts.

The **no** form of the command disables mirroring for the specified SAP. All mirroring for that SAP on ingress and egress is terminated. Mirroring of packets on the SAP can continue if more specific mirror criteria is configured. If the **egress** or **ingress** parameter keywords are specified in the **no** command, only the ingress or egress mirroring condition is removed.

**Default** No SAPs are defined by default.

**Parameters** *sap-id* — Specifies the physical port identifier portion of the SAP definition. See [Common CLI Command Descriptions on page 327](#) for command syntax.

*channel-id* — The SONET/SDH or TDM channel on the port of the SAP. A period separates the physical port from the *channel-id*. The port must be configured as an access port.

**egress** — Specifies that packets egressing the SAP should be mirrored. Egress packets are mirrored to the mirror destination after egress packet modification.

**ingress** — Specifies that packets ingressing the SAP should be mirrored. Ingress packets are mirrored to the mirror destination prior to ingress packet modification.

## ingress-label

**Syntax** **[no] ingress-label label [label ...up to 8 max]**  
**no ingress-label label [label ...up to 8 max]**

**Context** debug>mirror-source

**Description** This command enables ingress MPLS frame mirroring based on the top-of-stack MPLS label. Multiple labels can be defined simultaneously.

The **ingress-label** command is used to mirror ingressing MPLS frames with specific MPLS labels to a specific mirror destination. The ingress label must be at the top of the label stack and can only be mirrored to a single mirror destination. If the same label is defined with multiple mirror destinations, an error is generated and the original mirror destination remains.

The **ingress-label** mirror source overrides all other mirror source definitions. The MPLS frame is mirrored to the mirror destination as it is received on the ingress network port. The 7750 SR MPLS label space is global for the system. A specific label is mirrored to the mirror destination regardless of the ingress interface.

By default, no ingress MPLS frames are mirrored. The **ingress-label** command must be executed to start mirroring on a specific MPLS label.

The **no ingress-label** command removes all label mirroring for the mirror source. To stop mirroring on specific labels, use the **no ingress-label label** form of the command. Multiple labels may be given in a single **no ingress-label** command.

**Default** No ingress MPLS labels for mirroring are defined.

**Parameters** *label* — The top-of-stack label received on ingress to be mirrored. A label can only be mirrored to a single mirror destination.

If the label does not exist on any ingress network ports, no packets are mirrored for that label. An error will not occur. Once the label exists on a network port, ingress mirroring commences for that label.

**Values** 0 — 1048575. The local MPLS stack may not support portions of this range.

---

## Lawful Intercept Commands

### li

|                    |                                                                                    |
|--------------------|------------------------------------------------------------------------------------|
| <b>Syntax</b>      | li                                                                                 |
| <b>Context</b>     | config                                                                             |
| <b>Description</b> | This command configures the context to configure lawful intercept (LI) parameters. |

### li-source

|                    |                                                                                                                                                                                                                                                                                                        |                    |                |                  |                       |
|--------------------|--------------------------------------------------------------------------------------------------------------------------------------------------------------------------------------------------------------------------------------------------------------------------------------------------------|--------------------|----------------|------------------|-----------------------|
| <b>Syntax</b>      | [no] li-source <i>service-id</i>                                                                                                                                                                                                                                                                       |                    |                |                  |                       |
| <b>Context</b>     | config>li                                                                                                                                                                                                                                                                                              |                    |                |                  |                       |
| <b>Description</b> | This command configures a lawful intercept (LI) mirror source.                                                                                                                                                                                                                                         |                    |                |                  |                       |
| <b>Parameters</b>  | <i>service-id</i> — The service identification identifies the service in the service domain. This ID is unique to this service and cannot be used by any other service, regardless of service type. The same service ID must be configured on every router that this particular service is defined on. |                    |                |                  |                       |
| <b>Values</b>      | <table> <tr> <td><i>service-id:</i></td> <td>1 — 2147483647</td> </tr> <tr> <td><i>svc-name:</i></td> <td>64 characters maximum</td> </tr> </table>                                                                                                                                                    | <i>service-id:</i> | 1 — 2147483647 | <i>svc-name:</i> | 64 characters maximum |
| <i>service-id:</i> | 1 — 2147483647                                                                                                                                                                                                                                                                                         |                    |                |                  |                       |
| <i>svc-name:</i>   | 64 characters maximum                                                                                                                                                                                                                                                                                  |                    |                |                  |                       |

### ip-filter

|                    |                                                                                                                                                                                                                                                                                                                                                                                                                                                                                                                                                                                                                                                                                                                                                                                                                                                                                                                                                                                          |
|--------------------|------------------------------------------------------------------------------------------------------------------------------------------------------------------------------------------------------------------------------------------------------------------------------------------------------------------------------------------------------------------------------------------------------------------------------------------------------------------------------------------------------------------------------------------------------------------------------------------------------------------------------------------------------------------------------------------------------------------------------------------------------------------------------------------------------------------------------------------------------------------------------------------------------------------------------------------------------------------------------------------|
| <b>Syntax</b>      | <b>ip-filter</b> <i>ip-filter-id</i> <b>entry</b> <i>entry-id</i> [ <i>entry-id...</i> ]<br><b>no ip-filter</b> <i>ip-filter-id</i> [ <b>entry</b> <i>entry-id...</i> ]                                                                                                                                                                                                                                                                                                                                                                                                                                                                                                                                                                                                                                                                                                                                                                                                                  |
| <b>Context</b>     | config>li>li-source                                                                                                                                                                                                                                                                                                                                                                                                                                                                                                                                                                                                                                                                                                                                                                                                                                                                                                                                                                      |
| <b>Description</b> | <p>This command enables lawful interception (LI) of packets that match specific entries in an existing IP filter.</p> <p>The <b>ip-filter</b> command directs packets which match the defined list of entry IDs to be intercepted to the destination referenced by the <i>mirror-dest-service-id</i> of the <b>mirror-source</b>.</p> <p>The IP filter must already exist in order for the command to execute. Filters are configured in the <b>config&gt;filter</b> context. If the IP filter does not exist, an error will occur. If the filter exists but has not been associated with a SAP or IP interface, an error is not generated but mirroring will not be enabled (there are no packets to mirror). Once the IP filter is defined to a SAP, IP interface or subscriber, mirroring is enabled.</p> <p>If the IP filter is defined as ingress, only ingress packets are intercepted. Ingress packets are sent to the destination prior to any ingress packet modifications.</p> |

If the IP filter is defined as egress, only egress packets are intercepted. Egress packets are sent to the destination after all egress packet modifications.

An *entry-id* within an IP filter can only be intercepted to a single destination. If the same *entry-id* is defined multiple times, an error occurs and only the first definition is in effect.

By default, no packets matching any IP filters are intercepted. Interception of IP filter entries must be explicitly defined.

When the **no** command is executed with the **entry** keyword and one or more *entry-id*'s, interception of that list of *entry-id*'s is terminated within the *ip-filter-id*. If an *entry-id* is listed that does not exist, an error will occur and the command will not execute. If an *entry-id* is listed that is not currently being intercepted, no error will occur for that *entry-id* and the command will execute normally.

**Parameters** *ip-filter-id* — The IP filter ID whose entries are to be intercepted. If the *ip-filter-id* does not exist, an error will occur and the command will not execute. Intercepting packets will commence when the *ip-filter-id* is defined on a SAP or IP interface.

**entry** *entry-id* [*entry-id* ...] — The IP filter entries to use as match criteria for lawful intercept (LI). The **entry** keyword begins a list of *entry-id*'s for interception. Multiple *entry-id* entries can be specified with a single command. Each *entry-id* must be separated by a space. Up to <N><n> 8 entry IDs may be specified in a single command.

If an *entry-id* does not exist within the IP filter, an error occurs and the command will not execute.

If the filter's *entry-id* is renumbered within the IP filter definition, the old *entry-id* is removed but the new *entry-id* must be manually added to the configuration to include the new (renumbered) entry's criteria.

## mac-filter

**Syntax** **mac-filter** *mac-filter-id* **entry** *entry-id* [*entry-id*...]  
**no mac-filter** *mac-filter-id* [**entry** *entry-id*...]

**Context** config>li>li-source

**Description** This command enables lawful interception (LI) of packets that match specific entries in an existing MAC filter. Multiple entries can be created using unique entry-id numbers within the filter. The 7750 SR OS implementation exits the filter on the first match found and executes the actions in accordance with the accompanying action command. For this reason, entries must be sequenced correctly from most to least explicit.

An entry may not have any match criteria defined (in which case, everything matches) but must have at least the keyword **action** for it to be considered complete. Entries without the **action** keyword will be considered incomplete and hence will be rendered inactive.

The **no** form of the command removes the specified entry from the IP or MAC filter. Entries removed from the IP or MAC filter are immediately removed from all services or network ports where that filter is applied.

**Parameters** *mac-filter-id* — Specifies the MAC filter ID. If the *mac-filter-id* does not exist, an error will occur and the command will not execute.

**entry** *entry-id* [*entry-id* ...] — The MAC filter entries to use as match criteria.

### sap

|                    |                                                                                                                                                                                                                                                                                                                                                                                                                                                                                                                                          |
|--------------------|------------------------------------------------------------------------------------------------------------------------------------------------------------------------------------------------------------------------------------------------------------------------------------------------------------------------------------------------------------------------------------------------------------------------------------------------------------------------------------------------------------------------------------------|
| <b>Syntax</b>      | <b>sap</b> <i>sap-id</i> {[ <b>ingress</b> ] [ <b>egress</b> ]}<br><b>no sap</b> <i>sap-id</i> [ <b>ingress</b> ] [ <b>egress</b> ]                                                                                                                                                                                                                                                                                                                                                                                                      |
| <b>Context</b>     | config>li>li-source                                                                                                                                                                                                                                                                                                                                                                                                                                                                                                                      |
| <b>Description</b> | This command creates a service access point (SAP) within an LI configuration. The specified SAP must define a FastE, GigE, or XGigE, or XGigE access port with a dot1q, null, or q-in-q encapsulation type.<br><br>When the <b>no</b> form of this command is used on a SAP, the SAP with the specified port and encapsulation parameters is deleted.                                                                                                                                                                                    |
| <b>Default</b>     | none                                                                                                                                                                                                                                                                                                                                                                                                                                                                                                                                     |
| <b>Parameters</b>  | <i>sap-id</i> — Specifies the physical port identifier portion of the SAP definition. See <a href="#">Common CLI Command Descriptions on page 327</a> for command syntax.<br><br><b>egress</b> — Specifies that packets egressing the SAP should be mirrored. Egress packets are mirrored to the mirror destination after egress packet modification.<br><br><b>ingress</b> — Specifies that packets ingressing the SAP should be mirrored. Ingress packets are mirrored to the mirror destination prior to ingress packet modification. |

### subscriber

|                    |                                                                                                                                                                                                                                                                                                                                                                                                                                                                                                                                                                                                                                                                                                                                                                                                                                                                 |
|--------------------|-----------------------------------------------------------------------------------------------------------------------------------------------------------------------------------------------------------------------------------------------------------------------------------------------------------------------------------------------------------------------------------------------------------------------------------------------------------------------------------------------------------------------------------------------------------------------------------------------------------------------------------------------------------------------------------------------------------------------------------------------------------------------------------------------------------------------------------------------------------------|
| <b>Syntax</b>      | <b>subscriber</b> <i>sub-ident-string</i> [ <b>sap</b> <i>sap-id</i> [ <b>ip</b> <i>ip-address</i> ] [ <b>mac</b> <i>ieee-address</i> ]][ <b>sla-profile</b> <i>sla-profile-name</i> ] [ <b>fc</b> {[ <b>be</b> ] [ <b>I2</b> ] [ <b>af</b> ] [ <b>I1</b> ] [ <b>h2</b> ] [ <b>ef</b> ] [ <b>h1</b> ] [ <b>nc</b> ]}] {[ <b>ingress</b> ] [ <b>egress</b> ]}<br><b>no subscriber</b> <i>sub-ident-string</i>                                                                                                                                                                                                                                                                                                                                                                                                                                                    |
| <b>Context</b>     | config>li>li-source                                                                                                                                                                                                                                                                                                                                                                                                                                                                                                                                                                                                                                                                                                                                                                                                                                             |
| <b>Description</b> | This command adds hosts of a subscriber to mirroring service.                                                                                                                                                                                                                                                                                                                                                                                                                                                                                                                                                                                                                                                                                                                                                                                                   |
| <b>Parameters</b>  | <i>sub-ident-string</i> — Specifies the name of the subscriber identification policy.<br><br><i>sap-id</i> — Specifies the physical port identifier portion of the SAP definition. See <a href="#">Common CLI Command Descriptions on page 327</a> for command syntax.<br><br><i>ip-address</i> — The service IP address (system IP address) of the remote 7750 SR device sending LI traffic. If 0.0.0.0 is specified, any remote 7750 SR is allowed to send to this service.<br><br><b>Values</b> 1.0.0.1 — 223.255.255.254<br><br><b>mac</b> <i>mac-address</i> — Specify this optional parameter when defining a static host. The MAC address must be specified for <b>anti-spoof ip-mac</b> and <b>arp-populate</b> . Multiple static hosts may be configured with the same MAC address given that each definition is distinguished by a unique IP address. |

*sla-profile-name* — Specifies the SLA profile name.

**Values** 32 characters maximum.

**fc** — The name of the forwarding class with which to associate LI traffic. The forwarding class name must already be defined within the system. If the *fc-name* does not exist, an error will be returned and the **fc** command will have no effect. If the *fc-name* does exist, the forwarding class associated with *fc-name* will override the default forwarding class.

**Values** be, l2, af, l1, h2, ef, h1, nc

**ingress** — Specifies information for the ingress policy.

**egress** — Specifies information for the egress policy.

## log

|                    |                                                                                  |
|--------------------|----------------------------------------------------------------------------------|
| <b>Syntax</b>      | <b>log</b>                                                                       |
| <b>Context</b>     | config>li                                                                        |
| <b>Description</b> | This command enables the context to configure an event log for Lawful Intercept. |

## log-id

|                    |                                                                                                                                                                  |
|--------------------|------------------------------------------------------------------------------------------------------------------------------------------------------------------|
| <b>Syntax</b>      | <b>[no] log-id</b> <i>log-id</i>                                                                                                                                 |
| <b>Context</b>     | config>li>log                                                                                                                                                    |
| <b>Description</b> | This command configures an LI event log destination. The <i>log-id</i> is used to direct events, alarms/traps, and debug information to respective destinations. |
| <b>Parameters</b>  | <i>log-id</i> — The log ID number, expressed as a decimal integer.                                                                                               |
| <b>Values</b>      | 1 — 100                                                                                                                                                          |

## filter

|                    |                                                                                                                                                                                                                                                                                                                                                                                                                                                                                                                          |
|--------------------|--------------------------------------------------------------------------------------------------------------------------------------------------------------------------------------------------------------------------------------------------------------------------------------------------------------------------------------------------------------------------------------------------------------------------------------------------------------------------------------------------------------------------|
| <b>Syntax</b>      | <b>filter</b> <i>filter-id</i><br><b>no filter</b>                                                                                                                                                                                                                                                                                                                                                                                                                                                                       |
| <b>Context</b>     | config>li>log>log-id                                                                                                                                                                                                                                                                                                                                                                                                                                                                                                     |
| <b>Description</b> | This command adds an event filter policy with the log destination.<br><br>The <b>filter</b> command is optional. If no event filter is configured, all events, alarms and traps generated by the source stream will be forwarded to the destination.<br><br>An event filter policy defines (limits) the events that are forwarded to the destination configured in the <i>log-id</i> . The event filter policy can also be used to select the alarms and traps to be forwarded to a destination <b>snmp-trap-group</b> . |

## Configuration Commands

The application of filters for debug messages is limited to application and subject only.

Accounting records cannot be filtered using the **filter** command.

Only one filter-id can be configured per log destination.

The **no** form of the command removes the specified event filter from the *log-id*.

|                   |                                                                                                                                                                                                                      |
|-------------------|----------------------------------------------------------------------------------------------------------------------------------------------------------------------------------------------------------------------|
| <b>Default</b>    | <b>no filter</b> — No event filter policy is specified for a <i>log-id</i> .                                                                                                                                         |
| <b>Parameters</b> | <i>filter-id</i> . The event filter policy ID is used to associate the filter with the <i>log-id</i> configuration. The event filter policy ID must already be defined in <b>config&gt;log&gt;filter filter-id</b> . |
| <b>Values</b>     | 1 — 1000                                                                                                                                                                                                             |

## from

|                    |                                                                                                                                                                                                                                                         |
|--------------------|---------------------------------------------------------------------------------------------------------------------------------------------------------------------------------------------------------------------------------------------------------|
| <b>Syntax</b>      | <b>from</b> {[li]}<br><b>no from</b>                                                                                                                                                                                                                    |
| <b>Context</b>     | config>li>log>log-id                                                                                                                                                                                                                                    |
| <b>Description</b> | This command configures a bit mask that specifies the log event source stream(s) to be forwarded to the destination specified in the log destination (memory, session, SNMP). Events from more than one source can be forwarded to the log destination. |
| <b>Parameters</b>  | <b>li</b> — Specifies the <b>li</b> event stream that contains all events configured for Lawful Intercept activities. If the requestor does not have access to the <b>li</b> context, the event stream will fail.                                       |

## time-format

|                    |                                                                                                                                                                                                                               |
|--------------------|-------------------------------------------------------------------------------------------------------------------------------------------------------------------------------------------------------------------------------|
| <b>Syntax</b>      | <b>time-format</b> {local   utc}                                                                                                                                                                                              |
| <b>Context</b>     | config>li>log>log-id                                                                                                                                                                                                          |
| <b>Description</b> | This command specifies whether the time should be displayed in local or Coordinated Universal Time (UTC) format.                                                                                                              |
| <b>Default</b>     | <b>utc</b>                                                                                                                                                                                                                    |
| <b>Parameters</b>  | <b>local</b> — Specifies that timestamps are written in the system's local time.<br><b>utc</b> — Specifies that timestamps are written using the UTC value. This was formerly called Greenwich Mean Time (GMT) and Zulu time. |

to

|                    |                                                                                                                                                                                                                                                                                                                                                                                                                                   |
|--------------------|-----------------------------------------------------------------------------------------------------------------------------------------------------------------------------------------------------------------------------------------------------------------------------------------------------------------------------------------------------------------------------------------------------------------------------------|
| <b>Syntax</b>      | <b>to memory</b> [ <i>size</i> ]<br><b>to session</b><br><b>to snmp</b> [ <i>size</i> ]                                                                                                                                                                                                                                                                                                                                           |
| <b>Context</b>     | config>li>log>log-id                                                                                                                                                                                                                                                                                                                                                                                                              |
| <b>Description</b> | This command enables the context to configure the destination type for the event log.<br>The source of the data stream must be specified in the <b>from</b> command prior to configuring the destination with the <b>to</b> command.<br>The <b>to</b> command cannot be modified or re-entered. If the destination or maximum size of an SNMP or memory log needs to be modified, the log ID must be removed and then re-created. |
| <b>Parameters</b>  | <i>size</i> — The size parameter indicates the number of events that can be stored into memory.                                                                                                                                                                                                                                                                                                                                   |
|                    | <b>Default</b> 100                                                                                                                                                                                                                                                                                                                                                                                                                |
|                    | <b>Values</b> 50 — 1024                                                                                                                                                                                                                                                                                                                                                                                                           |

save

|                    |                                                               |
|--------------------|---------------------------------------------------------------|
| <b>Syntax</b>      | <b>save</b>                                                   |
| <b>Context</b>     | config>li                                                     |
| <b>Description</b> | This command is required to save LI configuration parameters. |

---

## Other LI Configuration Commands

The following commands are also described in the 7750 SR OS Basic System Configuration Guide.

### li-local-save

|                    |                                                                                                                                                                                            |
|--------------------|--------------------------------------------------------------------------------------------------------------------------------------------------------------------------------------------|
| <b>Syntax</b>      | <b>[no] li-local-save</b>                                                                                                                                                                  |
| <b>Context</b>     | bof                                                                                                                                                                                        |
| <b>Description</b> | This command specifies whether or not lawful intercept (LI) configuration is allowed to be save to a local file. Modifying this command will not take affect until the system is rebooted. |
| <b>Default</b>     | li-local-save                                                                                                                                                                              |

### li-separate

|                    |                                                                                                                                                                                                                                                                                                                                                                                                                                                                                                                                                                                                                                                                                                                                                                                                                                                                                                                                                                                                                                                                                                                                                                                                                                                                                                                                                                                                                                                                                                   |
|--------------------|---------------------------------------------------------------------------------------------------------------------------------------------------------------------------------------------------------------------------------------------------------------------------------------------------------------------------------------------------------------------------------------------------------------------------------------------------------------------------------------------------------------------------------------------------------------------------------------------------------------------------------------------------------------------------------------------------------------------------------------------------------------------------------------------------------------------------------------------------------------------------------------------------------------------------------------------------------------------------------------------------------------------------------------------------------------------------------------------------------------------------------------------------------------------------------------------------------------------------------------------------------------------------------------------------------------------------------------------------------------------------------------------------------------------------------------------------------------------------------------------------|
| <b>Syntax</b>      | <b>[no] li-separate</b>                                                                                                                                                                                                                                                                                                                                                                                                                                                                                                                                                                                                                                                                                                                                                                                                                                                                                                                                                                                                                                                                                                                                                                                                                                                                                                                                                                                                                                                                           |
| <b>Context</b>     | bof                                                                                                                                                                                                                                                                                                                                                                                                                                                                                                                                                                                                                                                                                                                                                                                                                                                                                                                                                                                                                                                                                                                                                                                                                                                                                                                                                                                                                                                                                               |
| <b>Description</b> | <p>This command specifies whether or not a non-LI user has access to lawful intercept (LI) information. When this command is enabled, a user who does not have LI access will not be allowed to access CLI or SNMP objects in the li context. Modifying this command will not take affect until the system is rebooted.</p> <p>When the <b>no li-separate</b> command is set (the default mode), those who are allowed access to the <b>config&gt;system&gt;security&gt;profile</b> context and user command nodes are allowed to modify the configuration of the LI parameters. In this mode, a user that has a profile allowing access to the <b>config&gt;li</b> and/or <b>show&gt;li</b> command contexts can enter and use the commands under those nodes.</p> <p>When the <b>li-separate</b> command is configured, only users that have the LI access capabilities set in the <b>config&gt;system&gt;security&gt;user&gt;access li</b> context are allowed to access the <b>config&gt;li</b> and/or <b>show&gt;li</b> command contexts. A user who does not have LI access is not allowed to enter the <b>config&gt;li</b> and <b>show&gt;li</b> contexts even though they have a profile that allows access to these nodes. When in the <b>li-separate</b> mode, only users with <b>config&gt;system&gt;security&gt;user&gt;access li</b> set in their user account have the ability modify the setting LI parameters in either their own or others profiles and user configurations.</p> |
| <b>Default</b>     | no li-separate                                                                                                                                                                                                                                                                                                                                                                                                                                                                                                                                                                                                                                                                                                                                                                                                                                                                                                                                                                                                                                                                                                                                                                                                                                                                                                                                                                                                                                                                                    |

## access

|                    |                                                                                                                                                                                                                                                                                                                                                                                                                                                                                                                                                                                                               |
|--------------------|---------------------------------------------------------------------------------------------------------------------------------------------------------------------------------------------------------------------------------------------------------------------------------------------------------------------------------------------------------------------------------------------------------------------------------------------------------------------------------------------------------------------------------------------------------------------------------------------------------------|
| <b>Syntax</b>      | <b>[no] access [ftp] [snmp] [console] [li]</b>                                                                                                                                                                                                                                                                                                                                                                                                                                                                                                                                                                |
| <b>Context</b>     | config>>system>security>user                                                                                                                                                                                                                                                                                                                                                                                                                                                                                                                                                                                  |
| <b>Description</b> | <p>This command grants a user permission for FTP, SNMP, console or lawful intercept (LI) access.</p> <p>If a user requires access to more than one application, then multiple applications can be specified in a single command. Multiple commands are treated additively.</p> <p>The <b>no</b> form of command removes access for a specific application.</p> <p><b>no access</b> denies permission for all management access methods. To deny a single access method, enter the <b>no</b> form of the command followed by the method to be denied, for example, <b>no access FTP</b> denies FTP access.</p> |
| <b>Default</b>     | No access is granted to the user by default.                                                                                                                                                                                                                                                                                                                                                                                                                                                                                                                                                                  |
| <b>Parameters</b>  | <p><b>ftp</b> — Specifies FTP permission.</p> <p><b>snmp</b> — Specifies SNMP permission. This keyword is only configurable in the <b>config&gt;system&gt;security&gt;user</b> context.</p> <p><b>console</b> — Specifies console access (serial port or Telnet) permission.</p> <p><b>li</b> — Allows user to access CLI commands in the lawful intercept (LI) context.</p>                                                                                                                                                                                                                                  |

## profile

|                    |                                                                                                                                                                                                                                                                                                                                                                                                                                                                                                                                                                          |
|--------------------|--------------------------------------------------------------------------------------------------------------------------------------------------------------------------------------------------------------------------------------------------------------------------------------------------------------------------------------------------------------------------------------------------------------------------------------------------------------------------------------------------------------------------------------------------------------------------|
| <b>Syntax</b>      | <b>[no] profile <i>user-profile-name</i></b>                                                                                                                                                                                                                                                                                                                                                                                                                                                                                                                             |
| <b>Context</b>     | config>system>security                                                                                                                                                                                                                                                                                                                                                                                                                                                                                                                                                   |
| <b>Description</b> | <p>This command creates a context to create user profiles for CLI command tree permissions.</p> <p>Profiles are used to either deny or permit user console access to a hierarchical branch or to specific commands.</p> <p>Once the profiles are created, the <b>user</b> command assigns users to one or more profiles. You can define up to 16 user profiles but a maximum of 8 profiles can be assigned to a user. The <i>user-profile-name</i> can consist of up to 32 alphanumeric characters.</p> <p>The <b>no</b> form of the command deletes a user profile.</p> |
| <b>Default</b>     | user-profile default                                                                                                                                                                                                                                                                                                                                                                                                                                                                                                                                                     |
| <b>Parameters</b>  | <i>user-profile-name</i> — The user profile name entered as a character string. The string is case sensitive and limited to 32 ASCII 7-bit printable characters with no spaces.                                                                                                                                                                                                                                                                                                                                                                                          |

## Configuration Commands

li

|                    |                                                                    |
|--------------------|--------------------------------------------------------------------|
| <b>Syntax</b>      | li                                                                 |
| <b>Context</b>     | config>system>security>profile                                     |
| <b>Description</b> | This command enables the Lawful Intercept (LI) profile identifier. |
| <b>Default</b>     | no li                                                              |

## Show Commands

### debug

|                    |                                                                                                                                                                                                                                                                                                                                                                                                                                                                                                                                                                                                                                                                                                                                                                                                                                                                                                                                                                                                                                                                                                                                                                                                                                                                                                                                                                                                                                                                   |
|--------------------|-------------------------------------------------------------------------------------------------------------------------------------------------------------------------------------------------------------------------------------------------------------------------------------------------------------------------------------------------------------------------------------------------------------------------------------------------------------------------------------------------------------------------------------------------------------------------------------------------------------------------------------------------------------------------------------------------------------------------------------------------------------------------------------------------------------------------------------------------------------------------------------------------------------------------------------------------------------------------------------------------------------------------------------------------------------------------------------------------------------------------------------------------------------------------------------------------------------------------------------------------------------------------------------------------------------------------------------------------------------------------------------------------------------------------------------------------------------------|
| <b>Syntax</b>      | <b>debug</b> [ <i>application</i> ]                                                                                                                                                                                                                                                                                                                                                                                                                                                                                                                                                                                                                                                                                                                                                                                                                                                                                                                                                                                                                                                                                                                                                                                                                                                                                                                                                                                                                               |
| <b>Context</b>     | <b>show</b>                                                                                                                                                                                                                                                                                                                                                                                                                                                                                                                                                                                                                                                                                                                                                                                                                                                                                                                                                                                                                                                                                                                                                                                                                                                                                                                                                                                                                                                       |
| <b>Description</b> | This command displays set debug points.                                                                                                                                                                                                                                                                                                                                                                                                                                                                                                                                                                                                                                                                                                                                                                                                                                                                                                                                                                                                                                                                                                                                                                                                                                                                                                                                                                                                                           |
| <b>Parameters</b>  | <p><i>application</i> — Display which debug points have been set.</p> <p><b>Values:</b> service, ip, ospf, ospf3, bgp, mtrace, rip, isis, mpls, rsvp, ldp, mirror, vrrp, system, filter, subscriber-mgmt, radius, lag, oam, frame-relay, local-dhcp-server, igmp, mld, pim</p>                                                                                                                                                                                                                                                                                                                                                                                                                                                                                                                                                                                                                                                                                                                                                                                                                                                                                                                                                                                                                                                                                                                                                                                    |
| <b>Output</b>      | <pre>*A:EsrC# show debug debug   mirror-source 100     subscriber "user1" ingress     subscriber "user2" fc be h2 h1 nc egress     subscriber "user3" ingress egress     subscriber "user4" sap 1/1/2:1 fc af ef nc ingress     subscriber "user5" sap 1/1/2:1 egress     subscriber "user6" sap 1/1/2:1 fc be l2 af h2 ef nc ingress egress     subscriber "user7" sap 1/1/2:1 ip 1.1.0.7 fc l1 h2 ingress     subscriber "user8" sap 1/1/2:1 ip 1.1.0.8 fc af l1 h2 ef nc egress     subscriber "user9" sap 1/1/2:1 ip 1.1.0.9 ingress egress     subscriber "user10" sap 1/1/2:1 mac 00:00:01:00:00:01 fc be l2 l1 h1 nc ingress   subscriber "user11" sap 1/1/2:1 mac 00:00:01:00:00:02 fc be l1 h2 ef h1 egress   subscriber "user12" sap 1/1/2:1 mac 00:00:01:00:00:03 fc be ef ingress egress   subscriber "user13" sap 1/1/2:1 ip 1.1.0.13 mac 00:00:01:00:00:01 fc be ef h1 ingress   subscriber "user14" sap 1/1/2:1 ip 1.1.0.14 mac 00:00:01:00:00:02 egress   subscriber "user15" sap 1/1/2:1 ip 1.1.0.15 mac 00:00:01:00:00:03 fc af l1 ef nc ingress egress   subscriber "user16" sla-profile "sla1" ingress   subscriber "user17" sla-profile "sla2" egress   subscriber "user18" sla-profile "sla3" fc be af h2 ingress egress no shutdown   exit exit *A:EsrC#  *A:alul# show debug debug   mirror-source 101     port 1/1/1 ingress     no shutdown   exit   mirror-source 102     port 1/1/3 egress     no shutdown   exit exit *A:alul#</pre> |

## active-subscribers

- Syntax**     **active-subscribers summary**  
**active-subscribers** [**subscriber** *sub-ident-string* [**sap** *sap-id* **sla-profile** *sla-profile-name*]]  
**[detail|mirror]**  
**active-subscribers hierarchy** [**subscriber** *sub-ident-string*]
- Context**     show>service
- Description**   This command displays active subscriber information.
- Parameters**   *sub-ident-string* — Specifies an existing subscriber identification string.
- sap** *sap-id* — Specifies the physical port identifier portion of the SAP definition. See “Common CLI Command Descriptions” on page 327 for command syntax.
- sla-profile-name* — Displays an existing SLA profile name.
- hierarchy* — Displays the subscriber hierarchy.
- summary* — Displays subscriber summary.

### Sample Output

```
*A:EsrC# show service active-subscribers mirror
=====
Active Subscribers
=====
Subscriber user1 (sub1)
-----
SLA Profile Instance sap:lag-8:1 - sla:sla1
-----
IP Address      MAC Address      Origin
-----
1.1.0.1         00:00:01:00:00:01 Static
                  Ingress mirror:   100   12 af 11 nc
-----
SLA Profile Instance sap:lag-8:11 - sla:sla1
-----
IP Address      MAC Address      Origin
-----
11.1.0.1        00:00:01:00:00:01 Static
                  Ingress mirror:   100   12 af 11 nc
-----
Subscriber user10 (sub1)
-----
SLA Profile Instance sap:lag-8:1 - sla:sla1
-----
IP Address      MAC Address      Origin
-----
1.1.0.10        00:00:01:00:00:01 Static
                  Ingress mirror:   100   af ef h1 nc
-----
Subscriber user11 (sub1)
-----
SLA Profile Instance sap:lag-8:1 - sla:sla1
-----
IP Address      MAC Address      Origin
-----
```

```

1.1.0.11      00:00:01:00:00:02 Static
              Egress mirror:      100  12 ef h1
-----
Subscriber user12 (sub1)
-----
SLA Profile Instance sap:lag-8:1 - sla:sla1
-----
IP Address      MAC Address      Origin
-----
1.1.0.12      00:00:01:00:00:03 Static
              Ingress mirror:      100  be 12 af 11 h2 ef h1 nc
              Egress mirror:      100  be 12 af 11 h2 ef h1 nc
-----
Subscriber user13 (sub1)
-----
SLA Profile Instance sap:lag-8:1 - sla:sla1
-----
IP Address      MAC Address      Origin
-----
1.1.0.13      00:00:01:00:00:01 Static
              Ingress mirror:      100  11 ef h1
-----
Subscriber user14 (sub1)
-----
SLA Profile Instance sap:lag-8:1 - sla:sla1
-----
IP Address      MAC Address      Origin
-----
1.1.0.14      00:00:01:00:00:02 Static
              Egress mirror:      100  12 h2 ef h1
-----
Subscriber user15 (sub1)
-----
SLA Profile Instance sap:lag-8:1 - sla:sla1
-----
IP Address      MAC Address      Origin
-----
1.1.0.15      00:00:01:00:00:03 Static
              Ingress mirror:      100  11 nc
              Egress mirror:      100  11 nc
-----
Subscriber user16 (sub1)
-----
SLA Profile Instance sap:lag-8:1 - sla:sla1
-----
IP Address      MAC Address      Origin
-----
1.1.0.16      00:00:01:00:00:01 Static
              Ingress mirror:      100  be 12 af nc
-----
SLA Profile Instance sap:lag-8:11 - sla:sla1
-----
IP Address      MAC Address      Origin
-----
11.1.0.16     00:00:01:00:00:01 Static
              Ingress mirror:      100  be 12 af nc
-----
Subscriber user17 (sub1)
-----
SLA Profile Instance sap:lag-8:1 - sla:sla2
-----

```

```

IP Address      MAC Address      Origin
-----
1.1.0.17       00:00:01:00:00:01 Static
                Egress mirror:   100   af l1 h1
-----
SLA Profile Instance sap:lag-8:11 - sla:sla2
-----
IP Address      MAC Address      Origin
-----
11.1.0.17      00:00:01:00:00:01 Static
                Egress mirror:   100   af l1 h1
-----
Subscriber user18 (sub1)
-----
SLA Profile Instance sap:lag-8:1 - sla:sla3
-----
IP Address      MAC Address      Origin
-----
1.1.0.18       00:00:01:00:00:01 Static
                Ingress mirror:  100   h2
                Egress mirror:  100   h2
-----
SLA Profile Instance sap:lag-8:11 - sla:sla3
-----
IP Address      MAC Address      Origin
-----
11.1.0.18      00:00:01:00:00:01 Static
                Ingress mirror:  100   h2
                Egress mirror:  100   h2
-----
Subscriber user2 (sub1)
-----
SLA Profile Instance sap:lag-8:1 - sla:sla1
-----
IP Address      MAC Address      Origin
-----
1.1.0.2        00:00:01:00:00:01 Static
                Egress mirror:   100   be l2 af l1 h2 ef h1 nc
-----
SLA Profile Instance sap:lag-8:11 - sla:sla1
-----
IP Address      MAC Address      Origin
-----
11.1.0.2       00:00:01:00:00:01 Static
                Egress mirror:   100   be l2 af l1 h2 ef h1 nc
-----
Subscriber user3 (sub1)
-----
SLA Profile Instance sap:lag-8:1 - sla:sla1
-----
IP Address      MAC Address      Origin
-----
1.1.0.3        00:00:01:00:00:01 Static
                Ingress mirror:  100   be l2 af l1 h2 ef h1 nc
                Egress mirror:  100   be l2 af l1 h2 ef h1 nc
-----
SLA Profile Instance sap:lag-8:11 - sla:sla1
-----
IP Address      MAC Address      Origin
-----
11.1.0.3       00:00:01:00:00:01 Static

```

```

                Ingress mirror:    100   be 12 af 11 h2 ef h1 nc
                Egress  mirror:    100   be 12 af 11 h2 ef h1 nc
-----
Subscriber user4 (sub1)
-----
SLA Profile Instance sap:lag-8:1 - sla:sla1
-----
IP Address      MAC Address      Origin
-----
1.1.0.4         00:00:01:00:00:01 Static
                Ingress mirror:    100   be 12 af 11 h2 ef h1 nc
-----
Subscriber user5 (sub1)
-----
SLA Profile Instance sap:lag-8:1 - sla:sla1
-----
IP Address      MAC Address      Origin
-----
1.1.0.5         00:00:01:00:00:01 Static
                Egress  mirror:    100   be 12 af 11 h2 ef h1 nc
-----
Subscriber user6 (sub1)
-----
SLA Profile Instance sap:lag-8:1 - sla:sla1
-----
IP Address      MAC Address      Origin
-----
1.1.0.6         00:00:01:00:00:01 Static
                Ingress mirror:    100   be af 11 h2
                Egress  mirror:    100   be af 11 h2
-----
Subscriber user7 (sub1)
-----
SLA Profile Instance sap:lag-8:1 - sla:sla1
-----
IP Address      MAC Address      Origin
-----
1.1.0.7         00:00:01:00:00:01 Static
                Ingress mirror:    100   be 12 af 11 h2 ef h1 nc
-----
Subscriber user8 (sub1)
-----
SLA Profile Instance sap:lag-8:1 - sla:sla1
-----
IP Address      MAC Address      Origin
-----
1.1.0.8         00:00:01:00:00:01 Static
                Egress  mirror:    100   be af 11 h1 nc
-----
Subscriber user9 (sub1)
-----
SLA Profile Instance sap:lag-8:1 - sla:sla1
-----
IP Address      MAC Address      Origin
-----
1.1.0.9         00:00:01:00:00:01 Static
                Ingress mirror:    100   be 12 af 11 h2 ef h1 nc
                Egress  mirror:    100   be 12 af 11 h2 ef h1 nc
=====
*A:EsrC#

```

## service-using

- Syntax** `service-using [mirror]`
- Context** `show>service`
- Description** Displays mirror services.  
If no optional parameters are specified, all services defined on the system are displayed.
- Parameters** `mirror` — Displays mirror services.
- Output** **Show Service-Using Mirror** — The following table describes service-using mirror output fields:

| Label            | Description                                                                       |
|------------------|-----------------------------------------------------------------------------------|
| Service Id       | The service identifier.                                                           |
| Type             | Specifies the service type configured for the service ID.                         |
| Adm              | The desired state of the service.                                                 |
| Opr              | The operating state of the service.                                               |
| CustomerID       | The ID of the customer who owns this service.                                     |
| Last Mgmt Change | The date and time of the most recent management-initiated change to this service. |

### Sample Output

```
A:ALA-48# show service service-using mirror
=====
Services [mirror]
=====
ServiceId   Type      Adm   Opr      CustomerId  Last Mgmt Change
-----
218         Mirror    Up    Down     1            04/08/2007 13:49:57
318         Mirror    Down  Down     1            04/08/2007 13:49:57
319         Mirror    Up    Down     1            04/08/2007 13:49:57
320         Mirror    Up    Down     1            04/08/2007 13:49:57
1000        Mirror    Down  Down     1            04/08/2007 13:49:57
1216        Mirror    Up    Down     1            04/08/2007 13:49:57
1412412     Mirror    Down  Down     1            04/08/2007 13:49:57
-----
Matching Services : 7
=====
A:ALA-48#
```

## li-source

|                    |                                                                           |
|--------------------|---------------------------------------------------------------------------|
| <b>Syntax</b>      | <b>li-source</b> [ <i>service-id</i> ]                                    |
| <b>Context</b>     | show>li                                                                   |
| <b>Description</b> | Displays Lawful Intercept mirror configuration and operation information. |
| <b>Parameters</b>  | <i>service-id</i> — Specifies the service ID.                             |
| <b>Values</b>      | 1 — 2147483647                                                            |

**Sample Output**

```
*A:sim138# show li li-source 2
=====
Mirror Service
=====
Service Id       : 2                Type           : Ether
Admin State      : Up                Oper State      : Up
Forwarding Class : be                Remote Sources : No
Slice            : 0
Destination SDP  : 1000 (100.1.1.2)    Egress Label   : 4000
Signaling        : None

-----
Local Sources
-----
Admin State      : Up

- IP Filter      1                Entry 1
=====
*A:sim138#
```

## log

|                    |                                                  |
|--------------------|--------------------------------------------------|
| <b>Syntax</b>      | <b>log</b>                                       |
| <b>Context</b>     | show>li                                          |
| <b>Description</b> | Displays Lawful Intercept event log information. |

## log-id

|                    |                                                                                                                                                                                                                                                                                                                                                                 |
|--------------------|-----------------------------------------------------------------------------------------------------------------------------------------------------------------------------------------------------------------------------------------------------------------------------------------------------------------------------------------------------------------|
| <b>Syntax</b>      | <b>log-id</b> [ <i>log-id</i> ] [ <b>severity</b> <i>severity-level</i> ] [ <b>application</b> <i>application</i> ] [ <b>sequence</b> <i>from-seq</i> [ <i>to-seq</i> ]] [ <b>count</b> <i>count</i> ] [ <b>router</b> <i>router-instance</i> [ <b>expression</b> ]] [ <b>subject</b> <i>subject</i> [ <b>regex</b> ]] [ <b>ascending</b>   <b>descending</b> ] |
| <b>Context</b>     | show>li>log                                                                                                                                                                                                                                                                                                                                                     |
| <b>Description</b> | Displays information for specified log.                                                                                                                                                                                                                                                                                                                         |
| <b>Parameters</b>  | <i>log-id</i> — Specifies the log ID.                                                                                                                                                                                                                                                                                                                           |

**Values** 1 — 100

*severity-level* — Specifies the severity level.

**Values** cleared, indeterminate, critical, major, minor, warning

*application* — Specifies the application name.

**Values** application\_assurance, aps, atm, bgp, cflowd, chassis, debug, dhcp, dhcps, dot1ag, efm\_oam, filter, gsmp, igmp, igmp\_snooping, ip, isis, lag, ldp, li, logger, mc\_redundancy, mirror, mld, mld\_snooping, mpls, msdp, ntp, oam, ospf, pim, pim\_snooping, port, ppp, pppoe, rip, route\_policy, rsvp, security, snmp, stp, svcmgr, system, user, vrrp, vrtr

*from-seq [to-seq]* — Specifies the sequence value.

**Values** 1 — 4294967295

*count* — Specifies the count.

**Values** 1 — 4294967295

*subject* — Specifies a subject string to match.

**reexp** — Specifies to use a regular expression match.

*ascending|descending* — Specifies the sort direction

*router-instance* — Specifies the router instance.

## status

|                    |                                               |
|--------------------|-----------------------------------------------|
| <b>Syntax</b>      | <b>status</b>                                 |
| <b>Context</b>     | show>li                                       |
| <b>Description</b> | Displays Lawful Intercept status information. |

### Sample Output

```
*A:sim138# show li status
=====
Lawful Intercept Status Information
=====
LI Booted Config Status      : fail
LI Local Save Allowed       : yes
Separate LI administration   : no
Last LI Config Save Time    : N/A
Last Config Save Result     : none
Changes Since Last Save     : yes
Last LI Config Modified Time : 2008/01/11 10:24:30
=====
*A:sim138#
```

li

|                    |                                             |
|--------------------|---------------------------------------------|
| <b>Syntax</b>      | li                                          |
| <b>Context</b>     | show                                        |
| <b>Description</b> | Displays Lawful Intercept (LI) information. |

## mirror mirror-dest

- Syntax** `mirror mirror-dest service-id`
- Context** show
- Description** This command displays mirror configuration and operation information.
- Parameters** *service-id* — Specify the mirror service ID.
- Output** **Mirroring Output** — The following table describes the mirroring output fields:

| Label            | Description                                                                                                                                                                                                                                                                                                                            |
|------------------|----------------------------------------------------------------------------------------------------------------------------------------------------------------------------------------------------------------------------------------------------------------------------------------------------------------------------------------|
| Service Id       | The service ID associated with this mirror destination.                                                                                                                                                                                                                                                                                |
| Type             | Entries in this table have an implied storage type of “volatile”. The configured mirror source information is not persistent.                                                                                                                                                                                                          |
| Admin State      | Up — The mirror destination is administratively enabled.<br>Down — The mirror destination is administratively disabled.                                                                                                                                                                                                                |
| Oper State       | Up — The mirror destination is operationally enabled.<br>Down — The mirror destination is operationally disabled.                                                                                                                                                                                                                      |
| Forwarding Class | The forwarding class for all packets transmitted to the mirror destination.                                                                                                                                                                                                                                                            |
| Remote Sources   | Yes — A remote source is configured.<br>No — A remote source is not configured.                                                                                                                                                                                                                                                        |
| Enable Port Id   | Yes — PPP Port ID Mirroring is enabled.<br>No — PPP Port ID Mirroring is disabled.                                                                                                                                                                                                                                                     |
| Slice            | The value of the slice-size, the maximum portion of the mirrored frame that will be transmitted to the mirror destination. Any frame larger than the slice-size will be truncated to this value before transmission to the mirror destination. A value of 0 indicates that mirrored packet truncation based on slice size is disabled. |
| Destination SAP  | The ID of the access port where the Service Access Point (SAP) associated with this mirror destination service is defined.                                                                                                                                                                                                             |
| Egr QoS Policy   | This value indicates the egress QoS policy ID. A value of 0 indicates that no QoS policy is specified.                                                                                                                                                                                                                                 |

### Sample Output

```
A:SR7# show mirror mirror-dest 1000
```

```
=====
```

```
Mirror Service
```

```

=====
Service Id      : 1000                Type           : Ether
Admin State    : Up                  Oper State     : Down
Forwarding Class : be                 Remote Sources: No
Slice          : 0
Destination SAP : 1/1/1              Egr QoS Policy: 1
-----
Local Sources
-----
Admin State    : Up
- Port        : 1/1/2                Egress Ingress
=====
A:SR7#

```

```

A:ALA-123>config>mirror# show mirror mirror-dest 500
=====
Mirror Service
=====
Service Id      : 500                Type           : Ether
Admin State    : Up                  Oper State     : Up
Forwarding Class : be                 Remote Sources: Yes
Destination SAP : 1/1/2              Egr QoS Policy: 1
-----
Remote Sources
-----
Far End        : 10.20.1.45          Ingress Label  : 131070
-----
Local Sources
-----
Admin State    : Up
No Mirror Sources configured
=====
A:ALA-123>config>mirror#

```

```

A:ALA-456# show mirror mirror-dest 500
=====
Mirror Service
=====
Service Id      : 500                Type           : Ether
Admin State    : Up                  Oper State     : Up
Forwarding Class : be                 Remote Sources: No
Destination SDP : 144 (10.20.1.44)   Egress Label  : 131070
Signaling:      : TLDP
-----
Local Sources
-----
Admin State    : Up
No Mirror Sources configured
=====
A:ALA-456#

```

```

A:NS042650115# show mirror mirror-dest 100
=====
Mirror Service
=====
Service Id      : 100                Type           : PPP
Admin State    : Up                  Oper State     : Up
Forwarding Class : be                 Remote Sources: No

```

```

Slice          : 0          Enable Port Id: Yes
Destination SDP : 100 (2.2.2.2) Egress Label : 131070
Signaling:     : TLDP

```

```
-----
Local Sources
-----
```

```
Admin State      : Up
No Mirror Sources configured
=====
```

```
A:NS042650115#
```

```
*A:EsrC# show mirror mirror-dest 100
```

```
=====
Mirror Service
=====
```

```
Service Id      : 100          Type          : Ether
Description     : Added by createMirrorDestination 100
Admin State     : Up          Oper State    : Up
Forwarding Class : be          Remote Sources: No
Slice          : 0
Destination SAP : 1/1/5:100    Egr QoS Policy: 1
-----
```

```
Local Sources
-----
```

```
Admin State      : Up
```

```

-Subs user1                      Ing
-Subs user2                      Egr
                                FC be h2 h1 nc
-Subs user3                      Egr Ing
-Subs user4                      1/1/2:1                      Ing
                                FC af ef nc
-Subs user5                      1/1/2:1                      Egr
-Subs user6                      1/1/2:1                      Egr Ing
                                FC be l2 af h2 ef nc
-Subs user7                      1/1/2:1                      Ing
    IP 1.1.0.7                    FC l1 h2
-Subs user8                      1/1/2:1                      Egr
    IP 1.1.0.8                    FC af l1 h2 ef nc
-Subs user9                      1/1/2:1                      Egr Ing
    IP 1.1.0.9                    FC
-Subs user10                     1/1/2:1                      Ing
                                MAC 00:00:01:00:00:01 FC be l2 l1 h1 nc
-Subs user11                     1/1/2:1                      Egr
                                MAC 00:00:01:00:00:02 FC be l1 h2 ef h1
-Subs user12                     1/1/2:1                      Egr Ing
                                MAC 00:00:01:00:00:03 FC be ef
-Subs user13                     1/1/2:1                      Ing
    IP 1.1.0.13                   MAC 00:00:01:00:00:01 FC be ef h1
-Subs user14                     1/1/2:1                      Egr
    IP 1.1.0.14                   MAC 00:00:01:00:00:02
-Subs user15                     1/1/2:1                      Egr Ing
    IP 1.1.0.15                   MAC 00:00:01:00:00:03 FC af l1 ef nc
-Subs user16                     SLA sla1                      Ing
-Subs user17                     SLA sla2                      Egr
-Subs user18                     SLA sla3                      Egr Ing
                                FC be af h2
=====
```

```
A:EsrC#
```

---

## Debug Commands

### subscriber

|                    |                                                                                                                                                                                                                                                                                                                                                                                                                                                                                                                                                                                                                                                                                                                                                                                                                                                                                                                                                                                                                                                                                                                                                           |
|--------------------|-----------------------------------------------------------------------------------------------------------------------------------------------------------------------------------------------------------------------------------------------------------------------------------------------------------------------------------------------------------------------------------------------------------------------------------------------------------------------------------------------------------------------------------------------------------------------------------------------------------------------------------------------------------------------------------------------------------------------------------------------------------------------------------------------------------------------------------------------------------------------------------------------------------------------------------------------------------------------------------------------------------------------------------------------------------------------------------------------------------------------------------------------------------|
| <b>Syntax</b>      | <b>subscriber</b> <i>sub-ident-string</i> [ <b>sap</b> <i>sap-id</i> [ <b>ip</b> <i>ip-address</i> ] [ <b>mac</b> <i>ieee-address</i> ]] <b>sla-profile</b> <i>sla-profile-name</i> ] [ <b>fc</b> {[ <b>be</b> ] [ <b>l2</b> ] [ <b>af</b> ] [ <b>l1</b> ] [ <b>h2</b> ] [ <b>ef</b> ] [ <b>h1</b> ] [ <b>nc</b> ]}] {[ <b>ingress</b> ] [ <b>egress</b> ]}<br><b>no subscriber</b> <i>sub-ident-string</i>                                                                                                                                                                                                                                                                                                                                                                                                                                                                                                                                                                                                                                                                                                                                               |
| <b>Context</b>     | debug>mirroring-source                                                                                                                                                                                                                                                                                                                                                                                                                                                                                                                                                                                                                                                                                                                                                                                                                                                                                                                                                                                                                                                                                                                                    |
| <b>Description</b> | This command adds hosts of a subscriber to mirroring service.                                                                                                                                                                                                                                                                                                                                                                                                                                                                                                                                                                                                                                                                                                                                                                                                                                                                                                                                                                                                                                                                                             |
| <b>Parameters</b>  | <i>sub-ident-string</i> — Specifies the name of the subscriber identification policy.<br><i>sap-id</i> — Specifies the physical port identifier portion of the SAP definition. See “Common CLI Command Descriptions” on page 327 for command syntax.<br><b>ip</b> <i>ip-address</i> — The service IP address (system IP address) of the remote 7750 SR device sending LI traffic.<br><b>Values</b> 1.0.0.1 — 223.255.255.254<br><b>mac</b> <i>mac-address</i> — Specify this optional parameter when defining a static host. The MAC address must be specified for <b>anti-spoof ip-mac</b> and <b>arp-populate</b> . Multiple static hosts may be configured with the same MAC address given that each definition is distinguished by a unique IP address.<br><b>sla-profile</b> <i>sla-profile-name</i> — Specifies the SLA profile name.<br><b>Values</b> 32 characters maximum.<br><b>fc</b> — The name of the forwarding class with which to associate LI traffic.<br><b>Values</b> be, l2, af, l1, h2, ef, h1, nc<br><b>ingress</b> — Specifies information for the ingress policy.<br><b>egress</b> — Specifies information for the egress policy. |

### ingress-label

|                    |                                                                                                                                            |
|--------------------|--------------------------------------------------------------------------------------------------------------------------------------------|
| <b>Syntax</b>      | <b>ingress-label</b> <i>label</i> [ <i>label</i> ...up to 8 max]<br><b>no ingress-label</b> [ <i>label</i> [ <i>label</i> ...up to 8 max]] |
| <b>Context</b>     | debug>mirror-source                                                                                                                        |
| <b>Description</b> | This command configures mirroring of ingress MPLS frames with a specific MPLS label to a mirror destination.                               |



# OAM and SAA

---

## In This Chapter

This chapter provides information about the Operations, Administration and Management (OAM) and Service Assurance Agent (SAA) commands available in the CLI for troubleshooting services.

Topics in this chapter include:

- [OAM Overview on page 122](#)
  - [LSP Diagnostics on page 122](#)
    - [LSP Ping for RSVP P2MP LSP \(P2MP\) on page 123](#)
    - [LSP Trace for RSVP P2MP LSP on page 125](#)
  - [SDP Diagnostics on page 129](#)
  - [Service Diagnostics on page 130](#)
  - [VPLS MAC Diagnostics on page 130](#)
  - [VLL Diagnostics on page 134](#)
  - [IGMP Snooping Diagnostics on page 142](#)
  - [ATM Diagnostics on page 143](#)
  - [End-to-End Testing of Paths in an LDP ECMP Network on page 144](#)
- [Ethernet Connectivity Fault Management \(ETH-CFM\) on page 147](#)
- [OAM Mapping on page 159](#)
- [Service Assurance Agent Overview on page 168](#)
  - [SAA Application on page 168](#)
  - [Configuring SAA Test Parameters on page 171](#)
- [Service Assurance Agent Overview on page 168](#)
  - [SAA Application on page 168](#)

## OAM Overview

Delivery of services requires a number of operations occur properly and at different levels in the service delivery model. For example, operations such as the association of packets to a service, VC-labels to a service and each service to a service tunnel must be performed properly in the forwarding plane for the service to function properly. In order to verify that a service is operational, a set of in-band, packet-based Operation, Administration, and Maintenance (OAM) tools is required, with the ability to test each of the individual packet operations.

For in-band testing, the OAM packets closely resemble customer packets to effectively test the customer's forwarding path, but they are distinguishable from customer packets so they are kept within the service provider's network and not forwarded to the customer.

The suite of OAM diagnostics supplement the basic IP ping and traceroute operations with diagnostics specialized for the different levels in the service delivery model. There are diagnostics for MPLS LSPs, SDPs, services and VPLS MACs within a service.

---

## LSP Diagnostics

The 7750 SR LSP diagnostics are implementations of LSP ping and LSP traceroute based on RFC 4379, *Detecting Multi-Protocol Label Switched (MPLS) Data Plane Failures*. In an LDP ECMP network, a unique-path trace can be accomplished by specifying a unique 127/8 IP address for the **path-destination ip-address** parameter. Note that the 7750 SR can send multipath type 0 or 8, and up to a maximum of 36 bytes for multipath length (refer to RFC 4379 for more details). The 7750 SR supports unique-path trace on an LER of an LDP ECMP path. LSP ping, as described in the draft, provides a mechanism to detect dataplane failures in MPLS LSPs. LSP ping and LSP traceroute are modeled after the ICMP echo request/reply used by ping and traceroute to detect and localize faults in IP networks.

For a given FEC, LSP ping verifies whether the packet reaches the egress label edge router (LER), while in LSP traceroute mode, the packet is sent to the control plane of each transit label switched router (LSR) which performs various checks to see if it is actually a transit LSR for the path.

## LSP Ping for RSVP P2MP LSP (P2MP)

Note: For more information about P2MP refer to the 7750 SR OS MPLS Guide.

The P2MP LSP ping complies to draft-ietf-mpls-p2mp-lsp-ping-06, *Detecting Data Plane Failures in Point-to-Multipoint Multiprotocol Label Switching (MPLS) - Extensions to LSP Ping*.

An LSP ping can be generated by entering the following OAM command:

```
oam p2mp-lsp-ping lsp-name [p2mp-instance instance-name [s2l-dest-addr
ip-address [...up to 5 max]]] [fc fc-name [profile {in | out}]] [size
octets] [ttl label-ttl] [timeout timeout] [detail]
```

The echo request message is sent on the active P2MP instance and is replicated in the data path over all branches of the P2MP LSP instance. By default, all egress LER nodes which are leaves of the P2MP LSP instance will reply to the echo request message.

The user can reduce the scope of the echo reply messages by explicitly entering a list of addresses for the egress LER nodes that are required to reply. A maximum of 5 addresses can be specified in a single execution of the **p2mp-lsp-ping** command. If all 5 egress LER nodes are 7750 nodes, they will be able to parse the list of egress LER addresses and will reply. Note however that draft-ietf-mpls-p2mp-lsp-ping-06 specifies that only the top address in the P2MP egress identifier TLV must be inspected by an egress LER. When interoperating with other implementations, an 7750 egress LER will respond if its address is anywhere in the list. Furthermore, if another vendor implementation is the egress LER, only the egress LER matching the top address in the TLV may respond.

If the user enters the same egress LER address more than once in a single p2mp-lsp-ping command, the head-end node displays a response to a single one and displays a single error warning message for the duplicate ones. When queried over SNMP, the head-end node issues a single response trap and issues no trap for the duplicates.

The **timeout** parameter should be set to the time it would take to get a response from all probed leaves under no failure conditions. For that purpose, its range extends to 120 seconds for a p2mp-lsp-ping from a 10 second lsp-ping for P2P LSP. The default value is 10 seconds.

A 7750 head-end node displays a “Send\_Fail” error when a specific S2L path is down only if the user explicitly listed the address of the egress LER for this S2L in the **ping** command.

Similarly, a 7750 head-end node displays the timeout error when no response is received for an S2L after the expiry of the timeout timer only if the user explicitly listed the address of the egress LER for this S2L in the **ping** command.

The user can configure a specific value of the **ttl** parameter to force the echo request message to expire on a 7750 branch node or a bud LSR node. The latter replies with a downstream mapping TLV for each branch of the P2MP LSP in the echo reply message. Note however that a maximum

of 16 downstream mapping TLVs can be included in a single echo reply message. It also sets the multipath type to zero in each downstream mapping TLV and will thus not include any egress address information for the reachable egress LER nodes for this P2MP LSP.

If a 7750 ingress LER node receives the new multipath type field with the list of egress LER addresses in an echo reply message from another vendor implementation, it will ignore but will not cause an error in processing the downstream mapping TLV.

If the ping expires at an LSR node which is performing a re-merge or cross-over operation in the data path between two or more ILMs of the same P2MP LSP, there will be an echo reply message for each copy of the echo request message received by this node.

The output of the command without the **detail** parameter specified provides a high-level summary of error codes and/or success codes received.

The output of the command with the **detail** parameter specified shows a line for each replying node as in the output of the LSP ping for a P2P LSP.

The display is delayed until all responses are received or the timer configured in the timeout parameter expired. No other CLI commands can be entered while waiting for the display. A control-C (^C) command will abort the ping operation.

## LSP Trace for RSVP P2MP LSP

The P2MP LSP trace complies to draft-ietf-mpls-p2mp-lsp-ping-06.

An LSP trace can be generated by entering the following OAM command:

```
oam p2mp-lsp-trace lsp-name p2mp-instance instance-name s2l-dest-address
ip-address [fc fc-name [profile {in|out}]] [size octets] [max-fail no-
response-count] [probe-count probes-per-hop] [min-ttl min-label-ttl]
[max-ttl max-label-ttl] [timeout timeout] [interval interval] [detail]
```

The LSP trace capability allows the user to trace the path of a single S2L path of a P2MP LSP. Its operation is similar to that of the **p2mp-lsp-ping** command but the sender of the echo reply request message includes the downstream mapping TLV to request the downstream branch information from a branch LSR or bud LSR. The branch LSR or bud LSR will then also include the downstream mapping TLV to report the information about the downstream branches of the P2MP LSP. An egress LER does not include this TLV in the echo response message.

The **probe-count** parameter operates in the same way as in LSP trace on a P2P LSP. It represents the maximum number of probes sent per TTL value before giving up on receiving the echo reply message. If a response is received from the traced node before reaching maximum number of probes, then no more probes are sent for the same TTL. The sender of the echo request then increments the TTL and uses the information it received in the downstream mapping TLV to start sending probes to the node downstream of the last node which replied. This continues until the egress LER for the traced S2L path replied.

Since the command traces a single S2L path, the timeout and interval parameters keep the same value range as in LSP trace for a P2P LSP.

The downstream mapping TLV is modified when used over a P2MP LSP (draft-ietf-mpls-p2mp-lsp-ping-06):

- A new B-flag is added to the downstream mapping TLV to indicate that the reporting LSR is not a branch for this LSP (cleared to zero) or is a branch (set to one).
- A new E-flag is added to the downstream mapping TLV to indicate that the reporting LSR is not a bud node for this LSP (cleared to zero) or is a bud node (set to one).
- The flags are placed in the fourth byte of the TLV that was previously reserved as shown below. All other fields are unchanged from their definitions in RFC 4379, *Detecting Multi-Protocol Label Switched (MPLS) Data Plane Failures*, except for the additional information that can be carried in the multipath information.

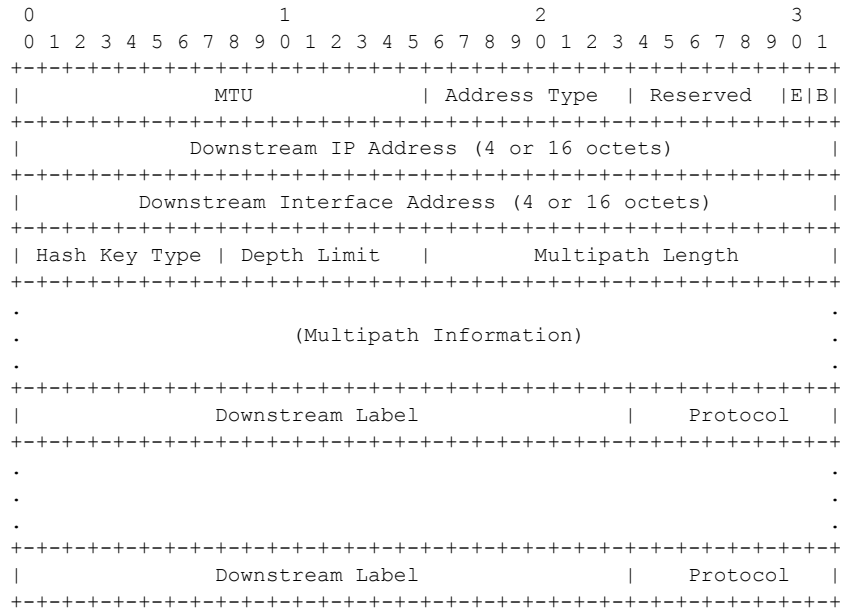

**Figure 16: Modifications to the Downstream Mapping TLV**

Note that the E-flag and B-flag are at bit positions 28 and 29 respectively. Bits 30 and 31 are already used as per RFC 4379. This error was reported to the authors of the draft.

Similar to p2mp-lsp-ping, an LSP trace probe results on all egress LER nodes eventually receiving the echo request message but only the traced egress LER node will reply to the last probe.

Also any branch LSR node or bud LSR node in the P2MP LSP tree may receive a copy of the echo request message with the TTL in the outer label expiring at this node. However, only a branch LSR or bud LSR which has a downstream branch over which the traced egress LER is reachable must respond.

When a branch LSR or bud LSR responds, it sets the B-flag in the downstream mapping TLV to indicate to the sender of the echo request message it has other branches for this LSP. A bud LSR will also set the E-flag in the downstream mapping TLV to indicate to the sender of the echo request message that it is also an egress LER for the P2MP LSP when the traced egress is reachable via a downstream branch. In this case, the return code must correspond to the LSR role and must code #8: "Label switched at stack-depth <RSC>"

Since a single egress LER address, for example an S2L path, can be traced, the branch LSR or bud LSR node will set the multipath type of zero in the downstream mapping TLV in the echo response message as no egress LER address need to be included.

## LSP Trace Behavior When S2L Path Traverses a Re-Merge Node

When a 7750 LSR performs a re-merge of one or more ILMs of the P2MP LSP to which the traced S2L sub-LSP belongs, it may block the ILM over which the traced S2L resides. This causes the trace to either fail or to succeed with a missing hop.

The following is an example of this behavior.

S2L1 and S2L2 use ILMs which re-merge at node B. Depending of which ILM is blocked at B, the TTL=2 probe will either yield two responses or will timeout.

```
S2L1 = ACBDF (to leaf F)
S2L2 = ABDE (to leaf E)
```

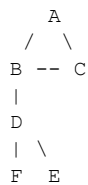

- Tracing S2L1 when ILM on interface C-B blocked at node B:

For TTL=1, A gets a response from C only as B does not have S2L1 on the ILM on interface A-B.

For TTL=2, assume A gets first the response from B which indicates a success. It then builds the next probe with TTL=3. B will only pass the copy of the message arriving on interface A-B and will drop the one arriving on interface C-B (treats it like a data packet since it does not expire at node B). This copy will expire at F. However F will return a **DSMAP mismatch** error because the DSMAP was the one provided by node B in TTL=2 step. The trace will abort at this point in time. However, A knows it got a second response from Node D for TTL=2 with a "DSMAP mismatch" error.

If A gets the response from D first with the error code, it waits to see if it gets a response from B or it times out. In either case, it will log this status as **multiple replies received per probe** in the last probe history and aborts the trace.

- Tracing S2L2 when ILM on interface A-B blocked at node B:

For TTL=1, B responds with a success. C does not respond as it does not have an ILM for S2L2.

For TTL=2, B drops the copy coming on interface A-B. It receives a copy coming on interface B-C but will drop it as the ILM does not contain S2L2. Node A times out. Next, node A generates a probe with TTL=3 without a DSMAP. This time node D will respond with a success and will include its downstream DSMAP to node E. The rest of the path will be discovered correctly. The traced path for S2L2 will look something like: A-B-(\*)-D-E.

A 7750 ingress LER detects a re-merge condition when it receives two or more replies to the same probe, such as the same TTL value. It displays the following message to the user regardless if the trace operation successfully reached the egress LER or was aborted earlier:

```
“Probe returned multiple responses. Result may be inconsistent.”
```

This warning message indicates to the user the potential of a re-merge scenario and that a p2mp-lsp-ping command for this S2L should be used to verify that the S2L path is not defective.

The 7750 ingress LER behavior is to always proceed to the next ttl probe when it receives an OK response to a probe or when it times out on a probe. If however it receives replies with an error return code, it must wait until it receives an OK response or it times out. If it times out without receiving an OK reply, the LSP trace must be aborted.

The following are possible echo reply messages received and corresponding ingress LER behavior:

- One or more error return codes + OK: display OK return code. Proceed to next ttl probe. Display warning message at end of trace.
- OK + One or more error return codes: display OK return code. Proceed to next ttl probe right after receiving the OK reply but keep state that more replies received. Display warning message at end of trace.
- OK + OK: should not happen for re-merge but would continue trace on 1st OK reply. This is the case when one of the branches of the P2MP LSP is activating the P2P bypass LSP. In this case, the head-end node will get a reply from both a regular P2MP LSR which has the ILM for the traced S2L and from an LSR switching the P2P bypass for other S2Ls. The latter does not have context for the P2MP LSP being tunneled but will respond after doing a label stack validation.
- One error return code + timeout: abort LSP trace and display error code. Ingress LER cannot tell the error is due to a re-merge condition.
- More than one error return code + timeout: abort LSP trace and display first error code. Display warning message at end of trace.
- Timeout on probe without any reply: display “\*” and proceed to next ttl probe.

## SDP Diagnostics

The 7750 SR OS SDP diagnostics are SDP ping and SDP MTU path discovery.

---

### SDP Ping

SDP ping performs in-band uni-directional or round-trip connectivity tests on SDPs. The SDP ping OAM packets are sent in-band, in the tunnel encapsulation, so it will follow the same path as traffic within the service. The SDP ping response can be received out-of-band in the control plane, or in-band using the data plane for a round-trip test.

For a uni-directional test, SDP ping tests:

- Egress SDP ID encapsulation
- Ability to reach the far-end IP address of the SDP ID within the SDP encapsulation
- Path MTU to the far-end IP address over the SDP ID
- Forwarding class mapping between the near-end SDP ID encapsulation and the far-end tunnel termination

For a round-trip test, SDP ping uses a local egress SDP ID and an expected remote SDP ID. Since SDPs are uni-directional tunnels, the remote SDP ID must be specified and must exist as a configured SDP ID on the far-end 7750 SR. SDP round trip testing is an extension of SDP connectivity testing with the additional ability to test:

- Remote SDP ID encapsulation
  - Potential service round trip time
  - Round trip path MTU
  - Round trip forwarding class mapping
- 

### SDP MTU Path Discovery

In a large network, network devices can support a variety of packet sizes that are transmitted across its interfaces. This capability is referred to as the Maximum Transmission Unit (MTU) of network interfaces. It is important to understand the MTU of the entire path end-to-end when provisioning services, especially for virtual leased line (VLL) services where the service must support the ability to transmit the largest customer packet.

The Path MTU discovery tool provides a powerful tool that enables service provider to get the exact MTU supported by the network's physical links between the service ingress and service termination points (accurate to one byte).

## Service Diagnostics

Alcatel-Lucent's Service ping feature provides end-to-end connectivity testing for an individual service. Service ping operates at a higher level than the SDP diagnostics in that it verifies an individual service and not the collection of services carried within an SDP.

Service ping is initiated from a 7750 SR router to verify round-trip connectivity and delay to the far-end of the service. Alcatel-Lucent's implementation functions for both GRE and MPLS tunnels and tests the following from edge-to-edge:

- Tunnel connectivity
- VC label mapping verification
- Service existence
- Service provisioned parameter verification
- Round trip path verification
- Service dynamic configuration verification

---

## VPLS MAC Diagnostics

While the LSP ping, SDP ping and service ping tools enable transport tunnel testing and verify whether the correct transport tunnel is used, they do not provide the means to test the learning and forwarding functions on a per-VPLS-service basis.

It is conceivable, that while tunnels are operational and correctly bound to a service, an incorrect Forwarding Information Base (FIB) table for a service could cause connectivity issues in the service and not be detected by the ping tools. Alcatel-Lucent has developed VPLS OAM functionality to specifically test all the critical functions on a per-service basis. These tools are based primarily on the IETF document draft-stokes-vkompella-ppvnp-hvpls-oam-xx.txt, *Testing Hierarchical Virtual Private LAN Services*.

The VPLS OAM tools are:

- **MAC Ping** — Provides an end-to-end test to identify the egress customer-facing port where a customer MAC was learned. MAC ping can also be used with a broadcast MAC address to identify all egress points of a service for the specified broadcast MAC.
- **MAC Trace** — Provides the ability to trace a specified MAC address hop-by-hop until the last node in the service domain. An SAA test with MAC trace is considered successful

when there is a reply from a far-end node indicating that they have the destination MAC address on an egress SAP or the CPM.

- **CPE Ping** — Provides the ability to check network connectivity to the specified client device within the VPLS. CPE ping will return the MAC address of the client, as well as the SAP and PE at which it was learned.
- **MAC Populate** — Allows specified MAC addresses to be injected in the VPLS service domain. This triggers learning of the injected MAC address by all participating nodes in the service. This tool is generally followed by MAC ping or MAC trace to verify if correct learning occurred.
- **MAC Purge** — Allows MAC addresses to be flushed from all nodes in a service domain.

## MAC Ping

For a MAC ping test, the destination MAC address (unicast or multicast) to be tested must be specified. A MAC ping packet can be sent through the control plane or the data plane. When sent by the control plane, the ping packet goes directly to the destination IP in a UDP/IP OAM packet. If it is sent by the data plane, the ping packet goes out with the data plane format.

In the control plane, a MAC ping is forwarded along the flooding domain if no MAC address bindings exist. If MAC address bindings exist, then the packet is forwarded along those paths (if they are active). Finally, a response is generated only when there is an egress SAP binding to that MAC address. A control plane request is responded to via a control reply only.

In the data plane, a MAC ping is sent with a VC label TTL of 255. This packet traverses each hop using forwarding plane information for next hop, VC label, etc. The VC label is swapped at each service-aware hop, and the VC TTL is decremented. If the VC TTL is decremented to 0, the packet is passed up to the management plane for processing. If the packet reaches an egress node, and would be forwarded out a customer facing port, it is identified by the OAM label below the VC label and passed to the management plane.

MAC pings are flooded when they are unknown at an intermediate node. They are responded to only by the egress nodes that have mappings for that MAC address.

## MAC Trace

A MAC trace functions like an LSP trace with some variations. Operations in a MAC trace are triggered when the VC TTL is decremented to 0.

Like a MAC ping, a MAC trace can be sent either by the control plane or the data plane.

For MAC trace requests sent by the control plane, the destination IP address is determined from the control plane mapping for the destination MAC. If the destination MAC is known to be at a

specific remote site, then the far-end IP address of that SDP is used. If the destination MAC is not known, then the packet is sent unicast, to all SDPs in the service with the appropriate squelching.

A control plane MAC traceroute request is sent via UDP/IP. The destination UDP port is the LSP ping port. The source UDP port is whatever the system gives (note that this source UDP port is really the demultiplexor that identifies the particular instance that sent the request, when correlating the reply). The source IP address is the system IP of the sender.

When a traceroute request is sent via the data plane, the data plane format is used. The reply can be via the data plane or the control plane.

A data plane MAC traceroute request includes the tunnel encapsulation, the VC label, and the OAM, followed by an Ethernet DLC, a UDP and IP header. If the mapping for the MAC address is known at the sender, then the data plane request is sent down the known SDP with the appropriate tunnel encapsulation and VC label. If it is not known, then it is sent down every SDP (with the appropriate tunnel encapsulation per SDP and appropriate egress VC label per SDP binding).

The tunnel encapsulation TTL is set to 255. The VC label TTL is initially set to the min-ttl (default is 1). The OAM label TTL is set to 2. The destination IP address is the all-routers multicast address. The source IP address is the system IP of the sender.

The destination UDP port is the LSP ping port. The source UDP port is whatever the system gives (note that this source UDP port is really the demultiplexor that identifies the particular instance that sent the request, when correlating the reply).

The Reply Mode is either 3 (i.e., reply via the control plane) or 4 (i.e., reply through the data plane), depending on the reply-control option. By default, the data plane request is sent with Reply Mode 3 (control plane reply).

The Ethernet DLC header source MAC address is set to either the system MAC address (if no source MAC is specified) or to the specified source MAC. The destination MAC address is set to the specified destination MAC. The EtherType is set to IP.

---

## CPE Ping

The MAC ping OAM tool makes it possible to detect whether a particular MAC address has been learned in a VPLS.

The **cpe-ping** command extends this capability to detecting end-station IP addresses inside a VPLS. A CPE ping for a specific destination IP address within a VPLS will be translated to a MAC-ping towards a broadcast MAC address. Upon receiving such a MAC ping, each peer PE within the VPLS context will trigger an ARP request for the specific IP address. The PE receiving a response to this ARP request will report back to the requesting 7750 SR. It is encouraged to use the source IP address of 0.0.0.0 to prevent the provider's IP address of being learned by the CE.

## MAC Populate

MAC populate is used to send a message through the flooding domain to learn a MAC address as if a customer packet with that source MAC address had flooded the domain from that ingress point in the service. This allows the provider to craft a learning history and engineer packets in a particular way to test forwarding plane correctness.

The MAC populate request is sent with a VC TTL of 1, which means that it is received at the forwarding plane at the first hop and passed directly up to the management plane. The packet is then responded to by populating the MAC address in the forwarding plane, like a conventional learn although the MAC will be an OAM-type MAC in the FIB to distinguish it from customer MAC addresses.

This packet is then taken by the control plane and flooded out the flooding domain (squelching appropriately, the sender and other paths that would be squelched in a typical flood).

This controlled population of the FIB is very important to manage the expected results of an OAM test. The same functions are available by sending the OAM packet as a UDP/IP OAM packet. It is then forwarded to each hop and the management plane has to do the flooding.

Options for MAC populate are to force the MAC in the table to type OAM (in case it already existed as dynamic or static or an OAM induced learning with some other binding), to prevent new dynamic learning to over-write the existing OAM MAC entry, to allow customer packets with this MAC to either ingress or egress the network, while still using the OAM MAC entry.

Finally, an option to flood the MAC populate request causes each upstream node to learn the MAC, for example, populate the local FIB with an OAM MAC entry, and to flood the request along the data plane using the flooding domain.

An age can be provided to age a particular OAM MAC after a different interval than other MACs in a FIB.

---

## MAC Purge

MAC purge is used to clear the FIBs of any learned information for a particular MAC address. This allows one to do a controlled OAM test without learning induced by customer packets. In addition to clearing the FIB of a particular MAC address, the purge can also indicate to the control plane not to allow further learning from customer packets. This allows the FIB to be clean, and be populated only via a MAC Populate.

MAC purge follows the same flooding mechanism as the MAC populate.

A UDP/IP version of this command is also available that does not follow the forwarding notion of the flooding domain, but the control plane notion of it.

## VLL Diagnostics

---

### VCCV Ping

VCCV ping is used to check connectivity of a VLL in-band. It checks that the destination (target) PE is the egress for the Layer 2 FEC. It provides a cross-check between the data plane and the control plane. It is in-band, meaning that the VCCV ping message is sent using the same encapsulation and along the same path as user packets in that VLL. This is equivalent to the LSP ping for a VLL service. VCCV ping reuses an LSP ping message format and can be used to test a VLL configured over an MPLS and GRE SDP.

---

### VCCV-Ping Application

VCCV effectively creates an IP control channel within the pseudowire between PE1 and PE2. PE2 should be able to distinguish on the receive side VCCV control messages from user packets on that VLL. There are three possible methods of encapsulating a VCCV message in a VLL which translates into three types of control channels:

1. Use of a Router Alert Label immediately above the VC label. This method has the drawback that if ECMP is applied to the outer LSP label (for example, transport label), the VCCV message will not follow the same path as the user packets. This effectively means it will not troubleshoot the appropriate path. This method is supported by the 7750 SR.
2. Use of the OAM control word as illustrated in [Figure 17](#).

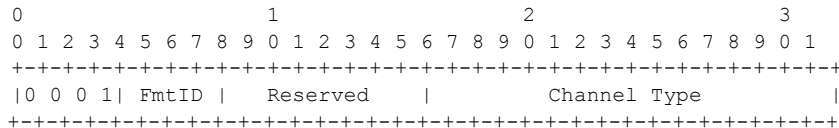

**Figure 17: OAM Control Word Format**

The first nibble is set to 0x1. The Format ID and the reserved fields are set to 0 and the channel type is the code point associated with the VCCV IP control channel as specified in the PWE3 IANA registry (RFC 4446). The channel type value of 0x21 indicates that the Associated Channel carries an IPv4 packet.

The use of the OAM control word assumes that the draft-martini control word is also used on the user packets. This means that if the control word is optional for a VLL and is not configured, the 7750 SR PE node will only advertise the router alert label as the CC capability in the Label Mapping message. This method is supported by the 7750 SR.

- Set the TTL in the VC label to 1 to force PE2 control plane to process the VCCV message. This method is not guaranteed to work under all circumstances. For instance, the draft mentions some implementations of penultimate hop popping overwrite the TTL field. This method is not supported by the 7750 SR.

When sending the label mapping message for the VLL, PE1 and PE2 must indicate which of the above OAM packet encapsulation methods (for example, which control channel type) they support. This is accomplished by including an optional VCCV TLV in the pseudowire FEC Interface Parameter field. The format of the VCCV TLV is shown in [Figure 18](#).

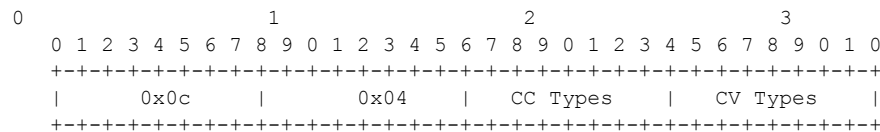

**Figure 18: VCCV TLV**

Note that the absence of the optional VCCV TLV in the Interface parameters field of the pseudowire FEC indicates the PE has no VCCV capability.

The Control Channel (CC) Type field is a bitmask used to indicate if the PE supports none, one, or many control channel types.

- 0x00 None of the following VCCV control channel types are supported
- 0x01 PWE3 OAM control word (see [Figure 17](#))
- 0x02 MPLS Router Alert Label
- 0x04 MPLS inner label TTL = 1

If both PE nodes support more than one of the CC types, then a 7750 SR PE will make use of the one with the lowest type value. For instance, OAM control word will be used in preference to the MPLS router alert label.

The Connectivity Verification (CV) bitmask field is used to indicate the specific type of VCCV packets to be sent over the VCCV control channel. The valid values are:

0x00 None of the below VCCV packet type are supported.

0x01 ICMP ping. Not applicable to a VLL over a MPLS or GRE SDP and as such is not supported by the 7750 SR.

0x02 LSP ping. This is used in VCCV-Ping application and applies to a VLL over an MPLS or a GRE SDP. This is supported by the 7750 SR.

A VCCV ping is an LSP echo request message as defined in RFC 4379. It contains an L2 FEC stack TLV which must include within the sub-TLV type 10 “FEC 128 Pseudowire”. It also

contains a field which indicates to the destination PE which reply mode to use. There are four reply modes defined in RFC 4379:

Reply mode, meaning:

1. Do not reply. This mode is supported by the 7750 SR.
2. Reply via an IPv4/IPv6 UDP packet. This mode is supported by the 7750 SR.
3. Reply with an IPv4/IPv6 UDP packet with a router alert. This mode sets the router alert bit in the IP header and is not be confused with the CC type which makes use of the router alert label. This mode is not supported by the 7750 SR.
4. Reply via application level control channel. This mode sends the reply message inband over the pseudowire from PE2 to PE1. PE2 will encapsulate the Echo Reply message using the CC type negotiated with PE1. This mode is supported by the 7750 SR.

The reply is an LSP echo reply message as defined in RFC 4379. The message is sent as per the reply mode requested by PE1. The return codes supported are the same as those supported in the 7750 SR LSP ping capability.

The VCCV ping feature is in addition to the service ping OAM feature which can be used to test a service between 7750 SR nodes. The VCCV ping feature can test connectivity of a VLL with any third party node which is compliant to RFC 5085.

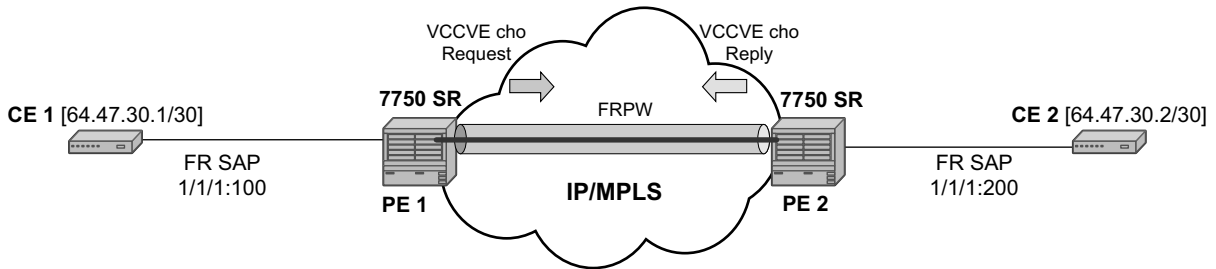

IPIPE\_010

Figure 19: VCCV-Ping Application

## VCCV-Ping in a Multi-Segment Pseudowire

Figure 20 displays an example of an application of VCCV ping over a multi-segment pseudowire.

Pseudowire switching is a method for scaling a large network of VLL or VPLS services by removing the need for a full mesh of T-LDP sessions between the PE nodes as the number of these nodes grows over time. Pseudowire switching is also used whenever there is a need to deploy a VLL service across two separate routing domains.

In the network, a Termination PE (T-PE) is where the pseudowire originates and terminates. The Switching PE (S-PE) is the node which performs pseudowire switching by cross-connecting two spoke SDPs.

VCCV ping is extended to be able to perform the following OAM functions:

1. VCCV ping to a destination PE. A VLL FEC Ping is a message sent by T-PE1 to test the FEC at T-PE2. The operation at T-PE1 and T-PE2 is the same as in the case of a single-segment pseudowire. The pseudowire switching node, S-PE1, pops the outer label, swaps the inner (VC) label, decrements the TTL of the VC label, and pushes a new outer label. The 7750 SR PE1 node does not process the VCCV OAM Control Word unless the VC label TTL expires. In that case, the message is sent to the CPM for further validation and processing. This is the method described in draft-hart-pwe3-segmented-pw-vcv.

Note that the originator of the VCCV ping message does not need to be a T-PE node; it can be an S-PE node. The destination of the VCCV ping message can also be an S-PE node.

VCCV trace to trace the entire path of a pseudowire with a single command issued at the T-PE. This is equivalent to LSP trace and is an iterative process by which T-PE1 sends successive VCCV ping messages while incrementing the TTL value, starting from TTL=1. The procedure for each iteration is the same as above and each node in which the VC label TTL expires checks the FEC and replies with the FEC to the downstream S-PE or T-PE node. The process is terminated when the reply is from T-PE2 or when a timeout occurs.

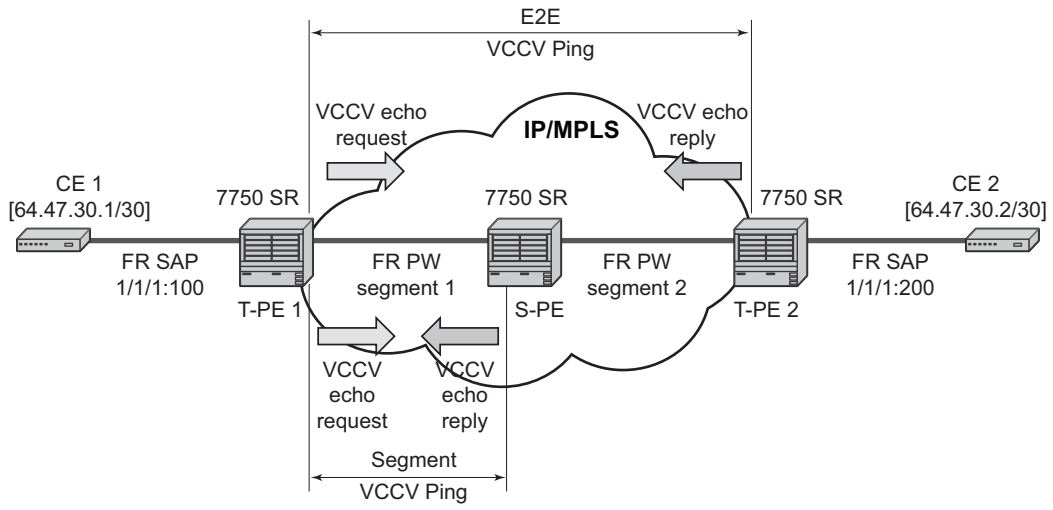

OSSG113

Figure 20: VCCV-Ping over a Multi-Segment Pseudowire

## Automated VCCV-Trace Capability for MS-Pseudowire

Although tracing of the MS-pseudowire path is possible using the methods explained in previous sections, these require multiple manual iterations and that the FEC of the last pseudowire segment to the target T-PE/S-PE be known a priori at the node originating the echo request message for each iteration. This mode of operation is referred to as a “ping” mode.

The automated VCCV-trace can trace the entire path of a pseudowire with a single command issued at the T-PE or at an S-PE. This is equivalent to LSP-trace and is an iterative process by which the ingress T-PE or T-PE sends successive VCCV-ping messages with incrementing the TTL value, starting from TTL=1.

The method is described in draft-hart-pwe3-segmented-pw-vccv, *VCCV Extensions for Segmented Pseudo-Wire*, and is pending acceptance by the PWE3 working group. In each iteration, the source T-PE or S-PE builds the MPLS echo request message in a way similar to [VCCV Ping on page 134](#). The first message with TTL=1 will have the next-hop S-PE T-LDP session source address in the Remote PE Address field in the pseudowire FEC TLV. Each S-PE which terminates and processes the message will include in the MPLS echo reply message the FEC 128 TLV corresponding the pseudowire segment to its downstream node. The inclusion of the FEC TLV in the echo reply message is allowed in RFC 4379, *Detecting Multi-Protocol Label Switched (MPLS) Data Plane Failures*. The source T-PE or S-PE can then build the next echo reply message with TTL=2 to test the next-next hop for the MS-pseudowire. It will copy the FEC TLV it received in the echo reply message into the new echo request message. The process is terminated when the reply is from the egress T-PE or when a timeout occurs. If specified, the max-ttl parameter in the vccv-trace command will stop on SPE before reaching T-PE.

The results VCCV-trace can be displayed for a fewer number of pseudowire segments of the end-to-end MS-pseudowire path. In this case, the min-ttl and max-ttl parameters are configured accordingly. However, the T-PE/S-PE node will still probe all hops up to min-ttl in order to correctly build the FEC of the desired subset of segments.

Note that this method does not require the use of the downstream mapping TLV in the echo request and echo reply messages.

---

## VCCV for Static Pseudowire Segments

MS pseudowire is supported with a mix of static and signaled pseudowire segments. However, VCCV ping and VCCV-trace is allowed until at least one segment of the MS pseudowire is static. Users cannot test a static segment but also, cannot test contiguous signaled segments of the MS-pseudowire. VCCV ping and VCCV trace is not supported in static-to-dynamic configurations.

## Detailed VCCV-Trace Operation

In [Figure 20 on page 138](#) a trace can be performed on the MS-pseudowire originating from T-PE1 by a single operational command. The following process occurs:

1. T-PE1 sends a VCCV echo request with TTL set to 1 and a FEC 128 containing the pseudowire information of the first segment (pseudowire1 between T-PE1 and S-PE) to S-PE for validation.
2. S-PE validates the echo request with the FEC 128. Since it is a switching point between the first and second segment it builds an echo reply with a return code of 8 and includes the FEC 128 of the second segment (pseudowire2 between S-PE and T-PE2) and sends the echo reply back to T-PE1.
3. T-PE1 builds a second VCCV echo request based on the FEC128 in the echo reply from the S-PE. It increments the TTL and sends the next echo request out to T-PE2. Note that the VCCV echo request packet is switched at the S-PE datapath and forwarded to the next downstream segment without any involvement from the control plane.
4. T-PE2 receives and validates the echo request with the FEC 128 of the pseudowire2 from T-PE1. Since T-PE2 is the destination node or the egress node of the MS-pseudowire it replies to T-PE1 with an echo reply with a return code of 3 (egress router) and no FEC 128 is included.
5. T-PE1 receives the echo reply from T-PE2. T-PE1 is made aware that T-PE2 is the destination of the MS pseudowire because the echo reply does not contain the FEC 128 and because its return code is 3. The trace process is completed.

## Control Plane Processing of a VCCV Echo Message in a MS-Pseudowire

---

### Sending a VCCV Echo Request

When in the ping mode of operation, the sender of the echo request message requires the FEC of the last segment to the target S-PE/T-PE node. This information can either be configured manually or be obtained by inspecting the corresponding sub-TLV's of the pseudowire switching point TLV. However, the pseudowire switching point TLV is optional and there is no guarantee that all S-PE nodes will populate it with their system address and the pseudowire-id of the last pseudowire segment traversed by the label mapping message. Thus the 7750 SR implementation will always make use of the user configuration for these parameters.

When in the trace mode operation, the T-PE will automatically learn the target FEC by probing one by one the hops of the MS-pseudowire path. Each S-PE node includes the FEC to the downstream node in the echo reply message in a similar way that LSP trace will have the probed node return the downstream interface and label stack in the echo reply message.

---

### Receiving an VCCV Echo Request

Upon receiving a VCCV echo request the control plane on S-PEs (or the target node of each segment of the MS pseudowire) validates the request and responds to the request with an echo reply consisting of the FEC 128 of the next downstream segment and a return code of 8 (label switched at stack-depth) indicating that it is an S-PE and not the egress router for the MS-pseudowire.

If the node is the T-PE or the egress node of the MS-pseudowire, it responds to the echo request with an echo reply with a return code of 3 (egress router) and no FEC 128 is included.

---

### Receiving an VCCV Echo Reply

The operation to be taken by the node that receives the echo reply in response to its echo request depends on its current mode of operation such as ping or trace.

In ping mode, the node may choose to ignore the target FEC 128 in the echo reply and report only the return code to the operator.

However, in trace mode, the node builds and sends the subsequent VCCV echo request with a incrementing TTL and the information (such as the downstream FEC 128) it received in the echo request to the next downstream pseudowire segment.

## IGMP Snooping Diagnostics

---

### MFIB Ping

The multicast forwarding information base (MFIB) ping OAM tool allows to easily verify inside a VPLS which SAPs would normally egress a certain multicast stream. The multicast stream is identified by a source unicast and destination multicast IP address, which are mandatory when issuing an MFIB ping command.

An MFIB ping packet will be sent through the data plane and goes out with the data plane format containing a configurable VC label TTL. This packet traverses each hop using forwarding plane information for next hop, VC label, etc. The VC label is swapped at each service-aware hop, and the VC TTL is decremented. If the VC TTL is decremented to 0, the packet is passed up to the management plane for processing. If the packet reaches an egress node, and would be forwarded out a customer facing port (SAP), it is identified by the OAM label below the VC label and passed to the management plane.

## ATM Diagnostics

The ATM OAM ping allows operators to test VC-integrity and endpoint connectivity for existing PVCCs using OAM loopback capabilities.

If portId:vpi/vci PVCC does not exist, a PVCC is administratively disabled, or there is already a ping executing on this PVCC, then this command returns an error.

Because oam atm-ping is a dynamic operation, the configuration is not preserved. The number of oam atm-ping operations that can be performed simultaneously on a 7750 SR is configurable as part of the general OAM MIB configuration.

An operator can specify the following options when performing an oam atm-ping:

**end-to-end** – this option allows sending oam atm-ping towards the connection endpoint in the line direction by using OAM end-to-end loopback cells

**segment** – this option allows sending oam atm-ping towards the segment termination point in the line direction by using OAM segment loopback cells.

The result of ATM ping will show if the ping to a given location was successful. It also shows the round-trip time the ping took to complete (from the time the ping was injected in the ATM SAR device until the time the ping response was given to S/W by the ATM SAR device) and the average ping time for successful attempts up to the given ping response.

An oam atm ping in progress will time-out if a PVCC goes to the operational status down as result of a network failure, an administrative action, or if a PVCC gets deleted. Any subsequent ping attempts will fail until the VC's operational state changes to up.

To stop a ping in progress, an operator can enter "CTRL – C". This will stop any outstanding ping requests and will return ping result up to the point of interruption (a ping in progress during the above stop request will fail).

## End-to-End Testing of Paths in an LDP ECMP Network

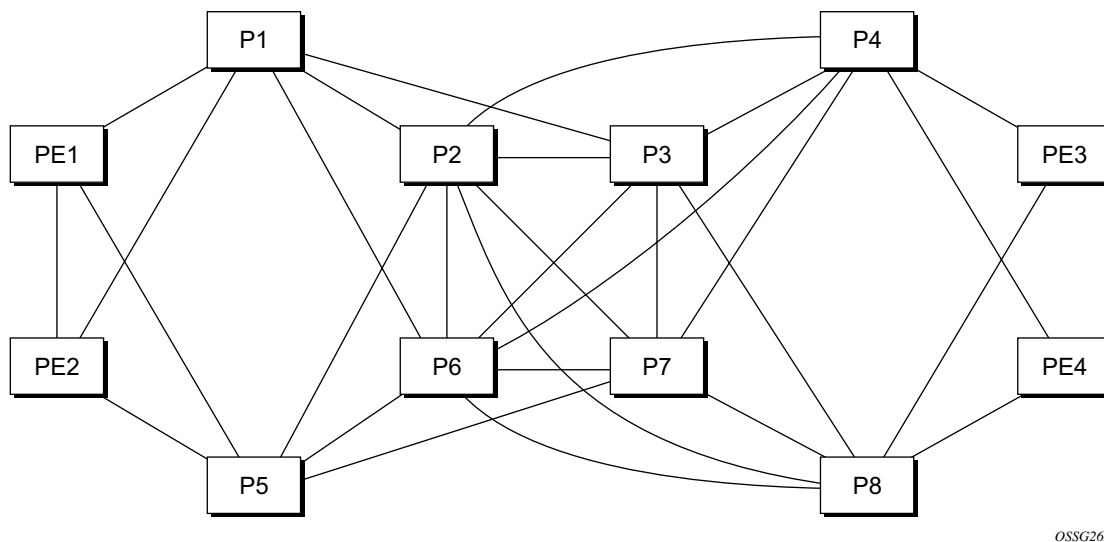

OSSG265

**Figure 21: Network Resilience Using LDP ECMP**

Figure 21 depicts an IP/MPLS network which uses LDP ECMP for network resilience. Faults that are detected through IGP and/or LDP are corrected as soon as IGP and LDP re-converge. The impacted traffic will be forwarded on the next available ECMP path as determined by the hash routine at the node that had a link failure.

However, there are faults which the IGP/LDP control planes may not detect. These faults may be due to a corruption of the control plane state or of the data plane state in a node. Although these faults are very rare and mostly due to misconfiguration, the LDP ECMP OAM is intended to detect these “silent” data plane and control plane faults. For example, it is possible that the forwarding plane of a node has a corrupt Next Hop Label Forwarding Entry (NLHFE) and keeps forwarding packets over an ECMP path only to have the downstream node discard them. This data plane fault can only be detected by an OAM tool that can test all possible end-to-end paths between the ingress LER and the egress LER. A corruption of the NLHFE entry can also result from a corruption in the control plane at that node.

## LDP ECMP Tree Building

The 7750 SR ingress LER builds the ECM tree for a given FEC (egress LER) by sending LSP trace messages and including the LDP IPv4 Prefix FEC TLV as well as the downstream mapping TLV. In order to build the ECMP tree, the 7750 SR LER inserts an IP address range drawn from the 127/8 space. When received by the downstream LSR, it will use this range to determine which ECMP path is exercised by any IP address or a sub-range of addresses within that range based on its internal hash routine. When the MPLS echo reply is received by the 7750 SR LER, it will record this information and proceed with the next echo request message targeted for a node downstream of the first LSR node along one of the ECMP paths. The sub-range of IP addresses indicated in the initial reply will be used since the objective is to have the LSR downstream of the 7750 SR LER pass this message to its downstream node along the first ECMP path.

The following figure illustrates the behavior through the following example adapted from RFC 4379, *Detecting Multi-Protocol Label Switched (MPLS) Data Plane Failures*:

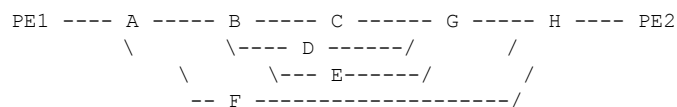

LSR A has two downstream LSRs, B and F, for PE2 FEC. PE1 receives an echo reply from A with the Multipath Type set to 4, with low/high IP addresses of 127.1.1.1->127.1.1.255 for downstream LSR B and 127.2.1.1->127.2.1.255 for downstream LSR F. PE1 reflects this information to LSR B. B, which has three downstream LSRs, C, D, and E, computes that 127.1.1.1->127.1.1.127 would go to C and 127.1.1.128-> 127.1.1.255 would go to D. B would then respond with 3 Downstream Mappings: to C, with Multipath Type 4 (127.1.1.1->127.1.1.127); to D, with Multipath Type 4 (127.1.1.127->127.1.1.255); and to E, with Multipath Type 0.

The 7750 SR supports multipath type 0 and 8, and up to a maximum of 36 bytes for the multipath length and supports the LER part of the LDP ECMP tree building feature.

A user configurable parameter sets the frequency of running the tree trace capability. The minimum and default value is 60 minutes and the increment is 1 hour.

The 7750 SR LER gets the list of FECs from the LDP FEC database. New FECs will be added to the discovery list at the next tree trace and not when they are learned and added into the FEC database. The maximum number of FECs to be discovered with the tree building feature is limited to 500. The user can configure FECs to exclude the use of a policy profile.

## Periodic Path Exercising

The periodic path exercising runs in the background to test the LDP ECMP paths discovered by the tree building capability. The probe used is an LSP ping message with an IP address drawn from the sub-range of 127/8 addresses indicated by the output of the tree trace for this FEC.

The periodic LSP ping messages continuously probes an ECMP path at a user configurable rate of at least 1 message per minute. This is the minimum and default value. The increment is 1 minute. If an interface is down on a 7750 SR LER, then LSP ping probes that normally go out this interface will not be sent.

The LSP ping routine updates the content of the MPLS echo request message, specifically the IP address, as soon as the LDP ECMP tree trace has output the results of a new computation for the path in question.

## Ethernet Connectivity Fault Management (ETH-CFM)

The IEEE and the ITU-T have cooperated to define the protocols, procedures and managed objects to support service based fault management. Both IEEE 802.1ag standard and the ITU-T Y.1731 recommendation support a common set of tools that allow operators to deploy the necessary administrative constructs, management entities and functionality, Ethernet Connectivity Fault Management (ETH-CFM). The ITU-T has also implemented a set of advanced ETH-CFM and performance management functions and features that build on the proactive and on demand troubleshooting tools.

CFM uses Ethernet frames and is distinguishable by ether-type 0x8902. In certain cases the different functions will use a reserved multicast address that could also be used to identify specific functions at the MAC layer. However, the multicast MAC addressing is not used for every function or in every case. The Operational Code (OpCode) in the common CFM header is used to identify the type of function carried in the CFM packet. CFM frames are only processed by IEEE MAC bridges. With CFM, interoperability can be achieved between different vendor equipment in the service provider network up to and including customer premises bridges. The following table lists CFM-related acronyms used in this section.

IEEE 802.1ag and ITU-T Y.1731 functions that are implemented are available on the SR and ESS platforms.

| Acronym | Callout                            |
|---------|------------------------------------|
| IDM     | One way Delay Measurement (Y.1731) |
| AIS     | Alarm Indication Signal            |
| CCM     | Continuity check message           |
| CFM     | Connectivity fault management      |
| DMM     | Delay Measurement Message (Y.1731) |
| DMR     | Delay Measurement Reply (Y.1731)   |
| LBM     | Loopback message                   |
| LBR     | Loopback reply                     |
| LTM     | Linktrace message                  |
| LTR     | Linktrace reply                    |
| ME      | Maintenance entity                 |
| MA      | Maintenance association            |
| MA-ID   | Maintenance association identifier |

| Acronym | Callout (Continued)                          |
|---------|----------------------------------------------|
| MD      | Maintenance domain                           |
| MEP     | Maintenance association end point            |
| MEP-ID  | Maintenance association end point identifier |
| MHF     | MIP half function                            |
| MIP     | Maintenance domain intermediate point        |
| OpCode  | Operational Code                             |
| RDI     | Remote Defect Indication                     |
| TST     | Ethernet Test (Y.1731)                       |

## ETH-CFM Building Blocks

The IEEE and the ITU-T use their own nomenclature when describing administrative contexts and functions. This introduces a level of complexity to configuration, discussion and different vendors naming conventions. The SR and ESS OS CLI has chosen to standardize on the IEEE 802.1ag naming where overlap exists. ITU-T naming is used, thus, no equivalent is available in the IEEE standard. In the following definitions, both the IEEE name and ITU-T names are provided for completeness, using the format IEEE Name/ITU-T Name.

Maintenance Domain (MD)/Maintenance Entity (ME) is the administrative container that defines the scope, reach and boundary for faults. It is typically the area of ownership and management responsibility. The IEEE allows for various formats to name the domain, allowing up to 45 characters, depending on the format selected. ITU-T supports only a format of “none” and does not accept the IEEE naming conventions.

0 — Undefined and reserved by the IEEE.

1 — No domain name. It is the only format supported by Y.1731 as the ITU-T specification does not use the domain name. This is supported in the IEEE 802.1ag standard but not in currently implemented for 802.1ag defined contexts.

2,3,4 — Provides the ability to input various different textual formats, up to 45 characters. The string format (2) is the default and therefore the keyword is not shown when looking at the configuration.

Maintenance Association (MA)/Maintenance Entity Group (MEG) is the construct where the different management entities will be contained. Each MA is uniquely identified by its MA-ID. The MA-ID is comprised of the by the MD level and MA name and associated format. This is another administrative context where the linkage is made between the domain and the service using the **bridging-identifier** configuration option. Currently the IEEE and the ITU-T use their own specific formats. As of writing, neither standards body supported the others formats. The MA short name formats (0-255) have been divided between the IEEE (0-31, 64-255) and the ITU-T (32-63), with five currently defined (1-4, 32).

1 (Primary VID) — Values 0 — 4094

2 (String) — Raw ASCII, excluding 0-31 decimal/0-1F hex (which are control characters) form the ASCII table

3 (2-octet integer) — 0 — 65535

4 (VPN ID) — Hex value as described in RFC 2685, *Virtual Private Networks Identifier*

32 (icc-format) — Exactly 13 characters from the ITU-T recommendation T.50.

Note: When a VID is used as the short MA name, 802.1ag will not support VLAN translation because the MA-ID must match all the MEPs. The default format for a short MA name is an integer. Integer value 0 means the MA is not attached to a VID. This is useful for VPLS services on SR/ESS platforms because the VID is locally significant.

Maintenance Domain Level (MD Level)/Maintenance Entity Group Level (MEG Level) is the numerical value (0-7) representing the width of the domain. The wider the domain, higher the numerical value, the farther the ETH-CFM packets can travel. It is important to understand that the level establishes the processing boundary for the packets. Strict rules control the flow of ETH-CFM packets and are used to ensure proper handling, forwarding, processing and dropping of these packets. To keep it simple ETH-CFM packets with higher numerical level values will flow through MEPs on MIPs on SAPs configured with lower level values. This allows the operator to implement different areas of responsibility and nest domains within each other. Maintenance association (MA) includes a set of MEPs, each configured with the same MA-ID and MD level used verify the integrity of a single service instance.

Maintenance Endpoint (MEP)/MEG Endpoint (MEP) are the workhorses of ETH-CFM. A MEP is the unique identification within the association (0-8191). Each MEP is uniquely identified by the MA-ID, MEPID tuple. This management entity is responsible for initiating, processing and terminating ETH-CFM functions, following the nesting rules. MEPs form the boundaries which prevent the ETH-CFM packets from flowing beyond the specific scope of responsibility. A MEP has direction, **up** or **down**. Each indicates the directions packets will be generated; UP toward the switch fabric, **down** toward the SAP away from the fabric. Each MEP has an active and passive side. Packets that enter the active point of the MEP will be compared to the existing level and processed accordingly. Packets that enter the passive side of the MEP are passed transparently through the MEP. Each MEP contained within the same maintenance association and with the

same level (MA-ID) represents points within a single service. MEP creation on a SAP is allowed only for Ethernet ports with NULL, q-tags, q-in-q encapsulations. MEPs may also be created on SDP bindings.

Maintenance Intermediate Point (MIP)/MEG Intermediate Point (MIP) are management entities between the terminating MEPs along the service path. These provide insight into the service path connecting the MEPs. MIPs only respond to Loopback Messages (LBM) and Linktrace Messages (LTM). All other CFM functions are transparent to these entities. Only one MIP is allowed per SAP or SDP. The creation of the MIPs can be done when the lower level domain is created (explicit) or manually (default). This is controlled by the use of the mhf-creation mode within the association under the bridge-identifier. MIP creation is supported on a SAP and SDP, not including Mesh SDP bindings. By default, no MIPs are created.

There are two locations in the configuration where ETH-CFM is defined. The domains, associations (including linkage to the service id), MIP creation method, common ETH-CFM functions and remote MEPs are defined under the top level **eth-cfm** command. It is important to note, when Y.1731 functions are required the context under which the MEPs are configured must follow the Y.1731 specific formats (domain format of none, MA format icc-format). Once these parameters have been entered, the MEP and possibly the MIP can be defined within the service under the SAP or SDP.

Not all service types support the different directions of MEPs or the creation of MIPs. The following table provides MEP/MIP support information.

| <b>Service</b>           | <b>Description</b>      | <b>MEP/MIP Support</b>    |
|--------------------------|-------------------------|---------------------------|
| Epipe (Ethernet SAP/SDP) | Ethernet Point to Point | Down MEP<br>Up MEP<br>MIP |
| Ipipe (Ethernet SAP)     | Point to Point          | Down MEP                  |
| VPLS (Ethernet SAP/SDP)  | Multipoint Ethernet     | Down MEP<br>Up MEP<br>MIP |
| IES (Ethernet SAP/SDP)   | Internet Enhanced       | Down MEP                  |
| VPRN (Ethernet SAP/SDP)  | Virtual Private Routed  | Down MEP                  |

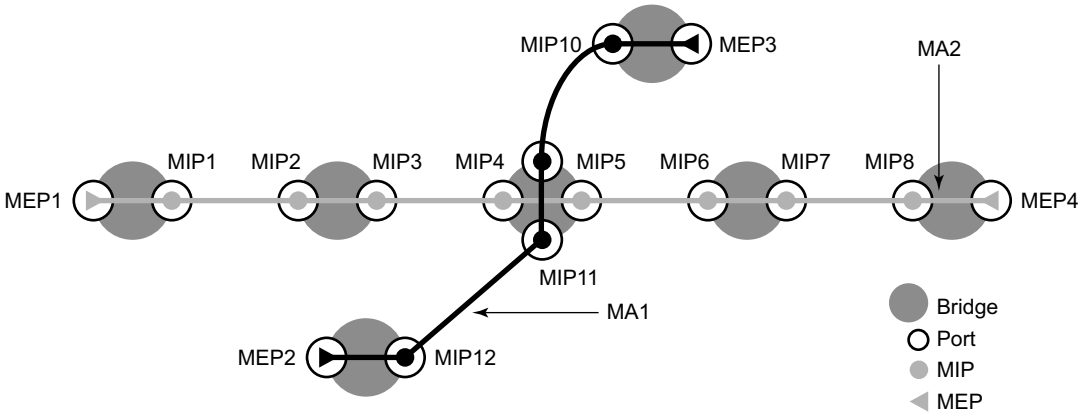

Figure 22: MEP and MIP

Figure 23 shows the detailed IEEE representation of MEPs, MIPs, levels and associations, using the standards defined icons.

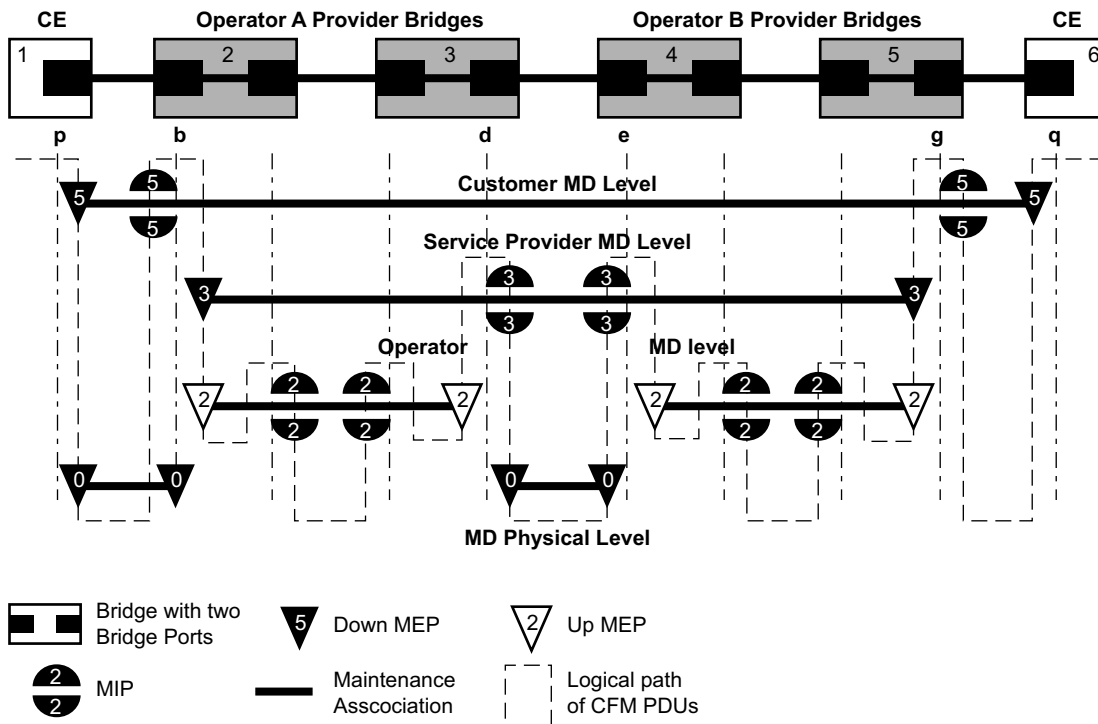
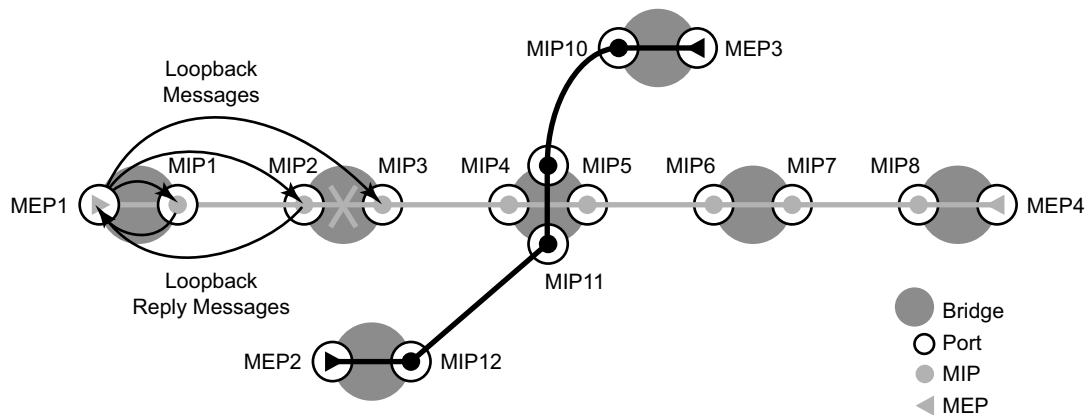

Figure 23: MEP, MIP and MD Levels

## Loopback

A loopback message is generated by an MEP to its peer MEP or a MIP (Figure 24). The functions are similar to an IP ping to verify Ethernet connectivity between the nodes.



**Figure 24: CFM Loopback**

The following loopback-related functions are supported:

- Loopback message functionality on an MEP or MIP can be enabled or disabled.
- MEP — Supports generating loopback messages and responding to loopback messages with loopback reply messages.
- MIP — Supports responding to loopback messages with loopback reply messages when loopback messages are targeted to self.
- Displays the loopback test results on the originating MEP.

## Linktrace

A linktrace message is originated by an MEP and targeted to a peer MEP in the same MA and within the same MD level (Figure 25). Its function is similar to IP traceroute. Traces a specific MAC address through the service. The peer MEP responds with a linktrace reply message after successful inspection of the linktrace message. The MIPs along the path also process the linktrace message and respond with linktrace replies to the originating MEP if the received linktrace message has a TTL greater than 1 and forward the linktrace message if a look up of the target MAC address in the Layer 2 FIB is successful. The originating MEP shall expect to receive multiple linktrace replies and from processing the linktrace replies, it can put together the route to the target bridge.

A traced MAC address is carried in the payload of the linktrace message. Each MIP and MEP receiving the linktrace message checks whether it has learned the target MAC address. In order to use linktrace the target MAC address must have been learned by the nodes in the network. If so, a linktrace message is sent back to the originating MEP. Also, a MIP forwards the linktrace message out of the port where the target MAC address was learned.

The linktrace message itself has a multicast destination address. On a broadcast LAN, it can be received by multiple nodes connected to that LAN. But, at most, one node will send a reply.

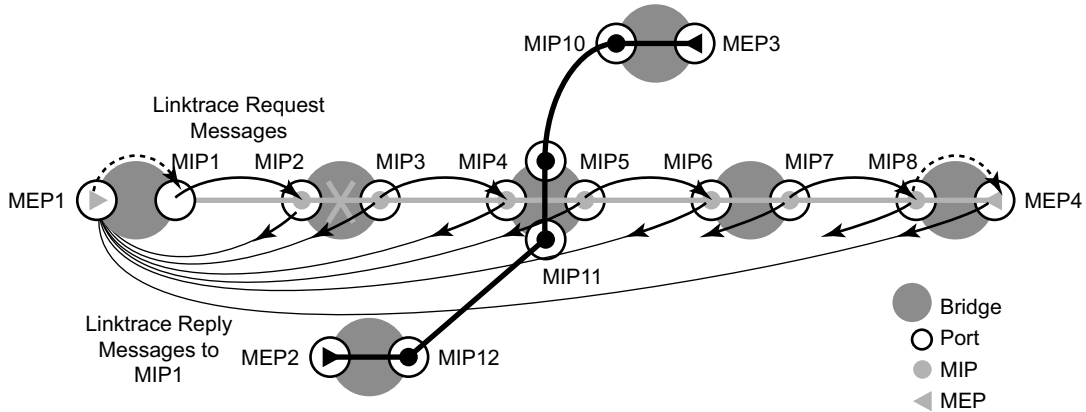

Figure 25: CFM Linktrace

The following linktrace related functions are supported:

- Enable or disables linktrace functions on an MEP.
- MEP — Supports generating linktrace messages and responding with linktrace reply messages.
- MIP — Supports responding to linktrace messages with linktrace reply messages when encoded TTL is greater than 1, and forward the linktrace messages accordingly if a lookup of the target MAC address in the Layer 2 FIB is successful.
- Displays linktrace test results on the originating MEP.

## Continuity Check (CC)

A Continuity Check Message (CCM) is a multicast frame that is generated by a MEP and multicast to all other MEPs in the same MA. The CCM does not require a reply message. To identify faults, the receiving MEP maintains an internal list of remote MEPs it should be receiving CCM messages from.

This list is based off of the remote-mepid configuration on the association that the MEP is created on. When the local MEP does not receive a CCM from one of the configured remote MEPs within a pre-configured period, the local MEP raises an alarm.

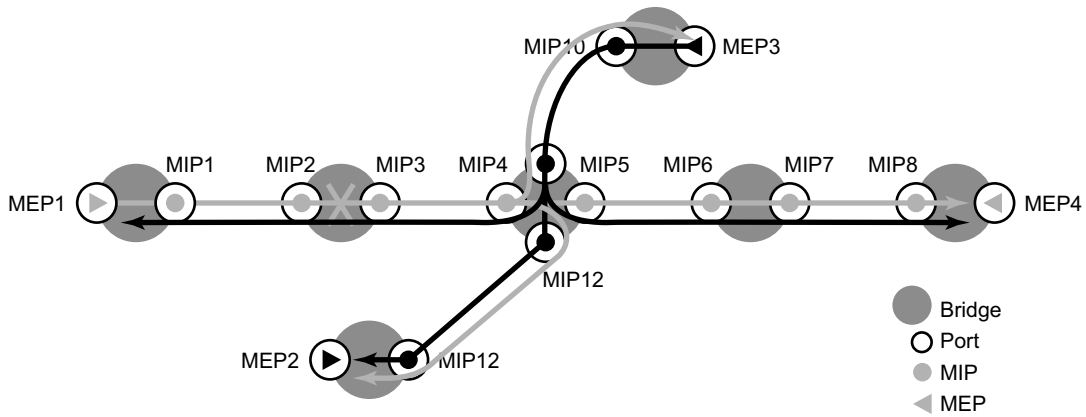

Figure 26: CFM Continuity Check

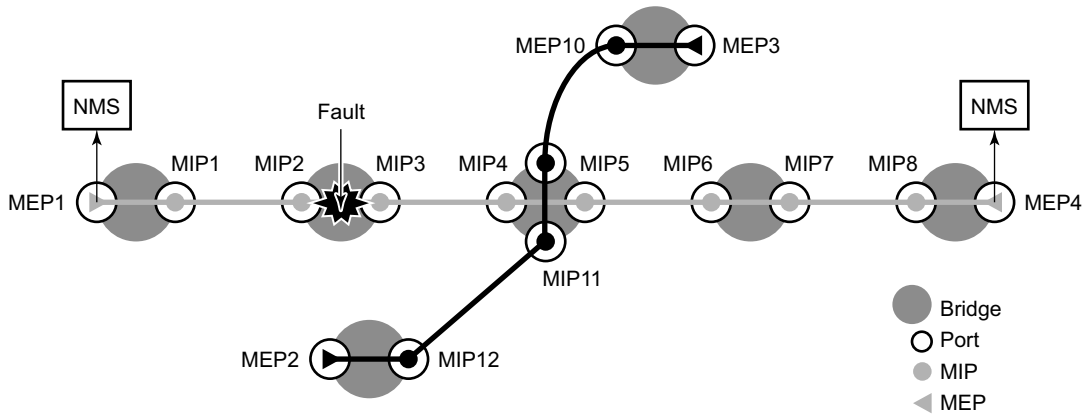

Figure 27: CFM CC Failure Scenario

The following functions are supported:

- Enable and disable CC for an MEP
- Configure and delete the MEP entries in the CC MEP monitoring database manually. It is only required to provision remote MEPs. Local MEPs shall be automatically put into the database when they are created.
- CCM transmit interval: 10ms, 100ms, 1s, 10s, 60s, 600s. Default: 10s. Sub-second or fast CC requires a ESS-7/ESS-12 and SR-7/SR-12 with a minimum SF/CPM-3, with only a limited number supported on SF/CPM-1 & SF/CPM-2. Sub-second enabled MEPs are supported on the following:
  - Down MEPs configured on Ethernet SAPs.
  - Lowest MD-level, when multiple MEPs exist on same Ethernet SAP.
  - Individual Ethernet tunnel paths requiring EAPs but not on the Ethernet tunnel itself. This requires a the MEPs to be part of the Y.1731 context because of the EAPS.
- CCM will declare a fault, when:
  - The CCM stops hearing from one of the remote MEPs for 3.5 times CC interval
  - Hears from a MEP with a LOWER MD level
  - Hears from a MEP that is not in our MA
  - Hears from a MEP that is in the same MA but not in the configured MEP list
  - Hears from a MEP in the same MA with the same MEP id as the receiving MEP
  - The CC interval of the remote MEP does not match the local configured CC interval
  - The remote MEP is declaring a fault
- An alarm is raised and a trap is sent if the defect is greater than or equal to the configured low-priority-defect value.
- Remote Defect Indication (RDI) is supported but by default is not recognized as a defect condition because the low-priority-defect setting default does not include RDI.

## **Alarm Indication Signal (ETH-AIS Y.1731)**

Alarm Indication Signal (AIS) provides an Y.1731 capable MEP the ability to signal a fault condition in the reverse direction of the MEP, out the passive side. When a fault condition is detected the MEP will generate AIS packets at the configured client levels and at the specified AIS interval until the condition is cleared. Currently a MEP configured to generate AIS must do so at a level higher than its own. The MEP configured on the service receiving the AIS packets is required to have the active side facing the receipt of the AIS packet and must be at the same level the AIS, The absence of an AIS packet for 3.5 times the AIS interval set by the sending node will clear the condition on the receiving MEP.

---

## **Test (ETH-TST Y.1731)**

Ethernet test affords operators an Y.1731 capable MEP the ability to send an in service on demand function to test connectivity between two MEPs. The test is generated on the local MEP and the results are verified on the destination MEP. Any ETH-TST packet generated that exceeds the MTU will be silently dropped by the lower level processing of the node.

---

## **One-Way Delay Measurement (ETH-1DM Y.1731)**

One-way delay measurement allows the operator the ability to check unidirectional delay between MEPs. An ETH-TST packet is time stamped by the generating MEP and sent to the remote node. The remote node time stamps the packet on receipt and generates the results. The results, available from the receiving MEP, will indicate the delay and jitter. Jitter, or delay variation, is the difference in delay between tests. This means the delay variation on the first test will not be valid. It is important to ensure that the clocks are synchronized on both nodes to ensure the results are accurate. NTP can be used to achieve a level of wall clock synchronization between the nodes. Note: accuracy relies on the nodes ability to timestamp the packet in hardware. Network elements that do not support this hardware time stamping, like the ESS-1 and SR-1, will display different results than hardware time stamp capable devices, like the SR-7/SR-12 and ESS-7/ESS-12.

---

## **Two-Way Delay Measurement (ETH-DMM Y.1731)**

Two-way delay measurement is similar to one way delay measurement except it measures the round trip delay from the generating MEP. In this case wall clock synchronization issues will not influence the test results because four timestamps are used. This allows the remote nodes time to be removed from the calculation and as a result clock variances are not included in the results. The same consideration for first test and hardware based time stamping stated for one way delay measurement are applicable to two-way delay measurement.

## OAM Mapping

OAM mapping is a mechanism that enables a way of deploying OAM end-to-end in a network where different OAM tools are used in different segments. For instance, an Epipe service could span across the network using Ethernet access (CFM used for OAM), pseudowire (T-LDP status signaling used for OAM), and Ethernet access (E-LMI used for OAM). Another example allows an Ipipe service, where one end is Ethernet and the other end is Frame Relay or ATM.

In the SR OS implementation, the Service Manager (SMGR) is used as the central point of OAM mapping. It receives and processes the events from different OAM components, then decide the actions to take, including triggering OAM events to remote peers.

Fault propagation for CFM is by default disabled at the MEP level to maintain backward compatibility. When required, it can be explicitly enabled by configuration.

Fault propagation for a MEP can only be enabled when the MA is comprised of no more than two MEPs (point-to-point).

Fault propagation cannot be enabled for eth-tun control MEPs (MEPs configured under the eth-tun primary and protection paths). However, failure of the eth-tun (meaning both paths fail) will be propagated by SMGR because all the SAPs on the eth-tun will go down.

## CFM Connectivity Fault Conditions

CFM MEP declares a connectivity fault when its defect flag is equal to or higher than its configured lowest defect priority. The defect can be any of the following depending on configuration:

- DefRDICCM
- DefMACstatus
- DefRemoteCCM
- DefErrorCCM
- DefXconCCM

The following additional fault condition applies to Y.1731 MEPs:

- Reception of AIS for the local MEP level

Setting the lowest defect priority to allDef may cause problems when fault propagation is enabled in the MEP. In this scenario, when MEP A sends CCM to MEP B with interface status down, MEP B will respond with a CCM with RDI set. If MEP A is configured to accept RDI as a fault, then it gets into a dead lock state, where both MEPs will declare fault and never be able to recover. The default lowest defect priority is DefMACstatus, which will not be a problem when interface status

TLV is used. It is also very important that different Ethernet OAM strategies should not overlap the span of each other. In some cases, independent functions attempting to perform their normal fault handling can negatively impact the other. This interaction can lead to fault propagation in the direction toward the original fault, a false positive, or worse, a deadlock condition that may require the operator to modify the configuration to escape the condition. For example, overlapping Link Loss Forwarding (LLF) and ETH-CFM fault propagation could cause these issues.

For the DefRemoteCCM fault, it is raised when any remote MEP is down. So whenever a remote MEP fails and fault propagation is enabled, a fault is propagated to SMGR.

---

## CFM Fault Propagation Methods

When CFM is the OAM module at the other end, it is required to use any of the following methods (depending on local configuration) to notify the remote peer:

- Generating AIS for certain MEP levels
- Sending CCM with interface status TLV “down”
- Stopping CCM transmission

For using AIS for fault propagation, AIS must be enabled for the MEP. The AIS configuration needs to be updated to support the MD level of the MEP (currently it only supports the levels above the local MD level).

Note that the existing AIS procedure still applies even when fault propagation is disabled for the service or the MEP. For example, when a MEP loses connectivity to a configured remote MEP, it generates AIS if it is enabled. The new procedure that is defined in this document introduces a new fault condition for AIS generation, fault propagated from SMGR, that is used when fault propagation is enabled for the service and the MEP.

The transmission of CCM with interface status TLV must be done instantly without waiting for the next CCM transmit interval. This rule applies to CFM fault notification for all services.

Notifications from SMGR to the CFM MEPs for fault propagation should include a direction for the propagation (up or down: up means in the direction of coming into the SAP/SDP-binding; down means in the direction of going out of the SAP/SDP-binding), so that the MEP knows what method to use. For instance, an up fault propagation notification to a down MEP will trigger an AIS, while a down fault propagation to the same MEP can trigger a CCM with interface TLV with status down.

For a specific SAP/SDP-binding, CFM and SMGR can only propagate one single fault to each other for each direction (up or down).

When there are multiple MEPs (at different levels) on a single SAP/SDP-binding, the fault reported from CFM to SMGR will be the logical OR of results from all MEPs. Basically, the first

fault from any MEP will be reported, and the fault will not be cleared as long as there is a fault in any local MEP on the SAP/SDP-binding.

## Epipse Services

Down and up MEPs are supported for Epipse services as well as fault propagation. When there are both up and down MEPs configured in the same SAP/SDP-binding and both MEPs have fault propagation enabled, a fault detected by one of them will be propagated to the other, which in turn will propagate fault in its own direction.

---

### CFM Detected Fault

When a MEP detects a fault and fault propagation is enabled for the MEP, CFM needs to communicate the fault to SMGR, so SMGR will mark the SAP/SDP-binding faulty but still oper-up. CFM traffic can still be transmitted to or received from the SAP/SDP-binding to ensure when the fault is cleared, the SAP will go back to normal operational state. Since the operational status of the SAP/SDP-binding is not affected by the fault, no fault handling is performed. For example, applications relying on the operational status are not affected.

If the MEP is an up MEP, the fault is propagated to the OAM components on the same SAP/SDP-binding; if the MEP is a down MEP, the fault is propagated to the OAM components on the mate SAP/SDP-binding at the other side of the service.

---

### SAP/SDP-Binding Failure (Including Pseudowire Status)

When a SAP/SDP-binding becomes faulty (oper-down, admin-down, or pseudowire status faulty), SMGR needs to propagate the fault to up MEP(s) on the same SAP/SDP-bindings about the fault, as well as to OAM components (such as down MEPs and E-LMI) on the mate SAP/SDP-binding.

---

### Service Down

This section describes procedures for the scenario where an Epipse service is down due to the following:

- Service is administratively shutdown. When service is administratively shutdown, the fault is propagated to the SAP/SDP-bindings in the service.
- If the Epipse service is used as a PBB tunnel into a B-VPLS, the Epipse service is also considered operationally down when the B-VPLS service is administratively shutdown or operationally down. If this is the case, fault is propagated to the Epipse SAP.
- In addition, one or more SAPs/SDP-bindings in the B-VPLS can be configured to propagate fault to this Epipse (see fault-propagation-bmac below). If the B-VPLS is operationally up but all of these entities have detected fault or are down, the fault is propagated to this Epipse's SAP.

## Interaction with Pseudowire Redundancy

When a fault occurs on the SAP side, the pseudowire status bit is set for both active and standby pseudowires. When only one of the pseudowire is faulty, SMGR does not notify CFM. The notification occurs only when both pseudowire becomes faulty. The SMGR propagates the fault to CFM.

Since there is no fault handling in the pipe service, any CFM fault detected on an SDP binding is not used in the pseudowire redundancy's algorithm to choose the most suitable SDP binding to transmit on.

---

## Ipipe Services

For Ipipe services, only down MEPs are supported on Ethernet SAPs.

---

## CFM Detected Fault

When a MEP detects a fault and fault propagation is enabled for the MEP, CFM needs to communicate the fault to SMGR, so SMGR will mark the SAP/SDP-binding faulty but still oper-up. CFM traffic can still be transmitted to or received from the SAP/SDP-binding to ensure when the fault is cleared, the SAP will go back to normal operational state.

Because the MEP is a down MEP, the fault is always propagated to the OAM components on the mate SAP/SDP-binding at the other side of the service.

---

## SAP/SDP-binding Failure (Including Pseudowire Status)

When a SAP/SDP-binding becomes faulty (oper-down, admin-down, or pseudowire status faulty), SMGR propagates the fault to OAM components on the mate SAP/SDP-binding.

---

## Service Administratively Shutdown

When the service is administratively shutdown, SMGR propagates the fault to OAM components on both SAP/SDP-bindings.

---

## Interaction with Pseudowire Redundancy

When the fault occurs on the SAP side, the pseudowire status bit is set for both active and standby pseudowires.

When only one of the pseudowire is faulty, SMGR does not notify CFM. The notification only occurs when both pseudowires become faulty. Then the SMGR propagates the fault to CFM. Since there is no fault handling in the PIPE service, any CFM fault detected on a SDP-binding is not used in the pseudowire redundancy's algorithm to choose the most suitable SDP-binding to transmit on.

---

## VPLS Service

For VPLS services, on down MEPs are supported for fault propagation.

---

## CFM Detected Fault

When a MEP detects a fault and fault propagation is enabled for the MEP, CFM communicate the fault to the SMGR. The SMGR will mark the SAP/SDP-binding as oper-down. Note that oper-down is used here in VPLS instead of “oper-up but faulty” in the pipe services. CFM traffic can be transmitted to or received from the SAP/SDP-binding to ensure when the fault is cleared, the SAP will go back to normal operational state.

Note that as stated in [CFM Connectivity Fault Conditions on page 159](#), a fault is raised whenever a remote MEP is down (not all remote MEPs have to be down). When it is not desirable to trigger fault handling actions in some cases when a down MEP has multiple remote MEPs, operators can disable fault propagation for the MEP.

If the MEP is a down MEP, SMGR performs the fault handling actions for the affected service(s). Local actions done by the SMGR include (but are not limited to):

- Flushing MAC addresses learned on the faulty SAP/SDP-binding.
- Triggering transmission of MAC flush messages.
- Notifying MSTP/RSTP about topology change. If the VPLS instance is a management VPLS (mVPLS), all VPLS instances that are managed by the m VPLS inherits the MSTP/RSTP state change and react accordingly to it.
- If the service instance is a B-VPLS, and fault-propagation-bmac address(es) is/are configured for the SAP/SDP-binding, SMGR performs a lookup using the BMAC address(es) to find out which pipe services need to be notified, then propagates a fault to these services. There can be up to four remote BMAC addresses associated with an SAP/SDP-binding for the same B-VPLS.

### **SAP/SDP-Binding Failure (Including Pseudowire Status)**

If the service instance is a B-VPLS, and an associated BMAC address is configured for the failed SAP/SDP-binding, the SMGR performs a lookup using the BMAC address to find out which pipe services will be notified and then propagate fault to these services.

Within the same B-VPLS service, all SAPs/SDP-bindings configured with the same fault propagation BMACs must be faulty or oper down for the fault to be propagated to the appropriate pipe services.

---

### **Service Down**

When a VPLS service is down:

- If the service is not a B-VPLS service, the SMGR propagates the fault to OAM components on all SAP/SDP-bindings in the service.
  - If the service is a B-VPLS service, the SMGR propagates the fault to OAM components on all SAP/SDP-bindings in the service as well as all pipe services that are associated with the B-VPLS instance.
- 

### **Pseudowire Redundancy and Spanning Tree Protocol**

A SAP or SDP binding that has a down MEP fault is made operationally down. This causes pseudowire redundancy or Spanning Tree Protocol (STP) to take the appropriate actions.

However, the reverse is not true. If the SAP or SDP binding is blocked by STP, or is not tx-active due to pseudowire redundancy, no fault is generated for this entity.

## IES and VPRN Services

For IES and VPRN services, only down MEP is supported on Ethernet SAPs and spoke SDP bindings.

When a down MEP detects a fault and fault propagation is enabled for the MEP, CFM communicates the fault to the SMGR. The SMGR marks the SAP/SDP binding as operationally down. CFM traffic can still be transmitted to or received from the SAP/SDP-binding to ensure when the fault is cleared and the SAP will go back to normal operational state.

Because the SAP/SDP-binding goes down, it is not usable to upper applications. In this case, the IP interface on the SAP/SDP-binding go down. The prefix is withdrawn from routing updates to the remote PEs. The same applies to subscriber group interface SAPs.

When the IP interface is administratively shutdown, the SMGR notifies the down MEP and a CFM fault notification is generated to the CPE through interface status TLV or suspension of CCM based on local configuration.

---

## Pseudowire Switching

When the node acts as a pseudowire switching node, meaning two pseudowires are stitched together at the node, the SMGR will not communicate pseudowire failures to CFM. Such features are expected to be communicated by pseudowire status messages, and CFM will run end-to-end on the head-end and tail-end of the stitched pseudowire for failure notification.

---

## LLF and CFM Fault Propagation

LLF and CFM fault propagation are mutually exclusive. CLI protection is in place to prevent enabling both LLF and CFM fault propagation in the same service, on the same node and at the same time. However, there are still instances where irresolvable fault loops can occur when the two schemes are deployed within the same service on different nodes. This is not preventable by the CLI. At no time should these two fault propagation schemes be enabled within the same service.

## 802.3ah EFM OAM Mapping and Interaction with Service Manager

802.3ah EFM OAM declares a link fault when any of the following occurs:

- Loss of OAMPDU for a certain period of time
- Receiving OAMPDU with link fault flags from the peer

When 802.3ah EFM OAM declares a fault, the port goes into operation state down. The SMGR communicates the fault to CFM MEPs in the service.

OAM fault propagation in the opposite direction (SMGR to EFM OAM) is not supported.

## Service Assurance Agent Overview

In the last few years, service delivery to customers has drastically changed. Services such as VPLS and VPRN are offered. The introduction of Broadband Service Termination Architecture (BSTA) applications such as Voice over IP (VoIP), TV delivery, video and high speed Internet services force carriers to produce services where the health and quality of Service Level Agreement (SLA) commitments are verifiable to the customer and internally within the carrier.

SAA is a feature that monitors network operations using statistics such as jitter, latency, response time, and packet loss. The information can be used to troubleshoot network problems, problem prevention, and network topology planning.

The results are saved in SNMP tables are queried by either the CLI or a management system. Threshold monitors allow for both rising and falling threshold events to alert the provider if SLA performance statistics deviate from the required parameters.

---

### SAA Application

SAA allows two-way timing for several applications. This provides the carrier and their customers with data to verify that the SLA agreements are being properly enforced.

Two-way time measures requests from this node to the specified DNS server. This is done by performing an address request followed by an immediate release of the acquired address once the time measurement has been performed.

---

### Traceroute Implementation

Various applications, such as lsp-trace, traceroute and vprn-trace, and traceroute, pass through the P-chip on the way to the control CPU. At this point, and when it egresses the control CPU, the P-chip should insert a timestamp inside the packet. Only packets processed by the Control CPU are processed.

When interpreting these timestamps care must be taken that some nodes are not capable of providing timestamps, as such timestamps must be associated with the same IP-address that is being returned to the originator to indicate what hop is being measured.

## NTP

Because NTP precision can vary (+/- 1.5ms between nodes even under best case conditions), SAA one-way latency measurements might display negative values, especially when testing network segments with very low latencies. The one-way time measurement relies on the accuracy of NTP between the sending and responding nodes.

---

## Ethernet CFM

Loopback (LBM), linktrace (LTR) and two-way-delay measurements (Y.1731 ETH-DMM) can be scheduled using SAA. Additional timestamping is required for non Y.1731 delay-measurement tests, to be specific, loopback and linktrace tests. An organization-specific TLV is used on both sender and receiver nodes to carry the timestamp information. Currently, timestamps are only applied by the sender node. This means any time measurements resulting from loopback and linktrace tests includes the packet processing time of the remote node. Since Y.1731 ETH-DMM uses a four time stamp approach to remove the remote processing time it should be used for accurate delay measurements.

The SAA versions of the CFM loopback, linktrace and ETH-DMM tests support send-count, interval, timeout, and FC. The existing CFM OAM commands have not been extended to support send-count and interval natively. The summary of the test results are stored in an accounting file that is specified in the SAA accounting-policy.

## Writing SAA Results to Accounting Files

SAA statistics enables writing statistics to an accounting file. When results are calculated an accounting record is generated.

In order to write the SAA results to an accounting file in a compressed XML format at the termination of every test, the results must be collected, and, in addition to creating the entry in the appropriate MIB table for this SAA test, a record must be generated in the appropriate accounting file.

---

## Accounting File Management

Because the SAA accounting files have a similar role to existing accounting files that are used for billing purposes, existing file management information is leveraged for these accounting (billing) files.

---

## Assigning SAA to an Accounting File ID

Once an accounting file has been created, accounting information can be specified and will be collected by the **config>log>acct-policy> to file** *log-file-id* context.

---

## Continuous Testing

When you configure a test, use the **config>saa>test>continuous** command to make the test run continuously. Use the **no continuous** command to disable continuous testing and **shutdown** to disable the test completely. Once you have configured a test as continuous, you cannot start or stop it by using the **saa test-name [owner test-owner] {start | stop} [no-accounting]** command.

## Configuring SAA Test Parameters

The following example displays an SAA configuration:

```
A:ALA-48>config>saa# info
-----
...
    test "vprnTr"
      type
        vprn-trace 5 source 20.20.12.1 destination 10.10.12.2
      exit
      jitter-event rising-threshold 5 falling-threshold 2 inbound
      jitter-event rising-threshold 5 falling-threshold 2 outbound
      jitter-event rising-threshold 6 falling-threshold 3
      loss-event rising-threshold 1 inbound
      loss-event rising-threshold 1 outbound
      loss-event rising-threshold 1
      latency-event rising-threshold 30 falling-threshold 1 inbound
      latency-event rising-threshold 30 falling-threshold 1 outbound
      latency-event rising-threshold 30 falling-threshold 1
      no shutdown
    exit
-----
A:ALA-48>config>saa#
```

After running the test twice, the result is displayed below:

```
*A:ALA-48>config>saa# show saa vprnTr
=====
SAA Test Information
=====
Test name           : vprnTr
Owner name          : TiMOS CLI
Description         : N/A
Accounting policy   : None
Administrative status : Enabled
Test type           : vprn-trace 5 source 20.20.12.1 destination 10.
                    : 10.12.2
Test runs since last clear : 0
Number of failed test runs : 0
Last test result    : Undetermined
-----
Threshold
Type      Direction Threshold Value      Last Event      Run #
-----
Jitter-in Rising      5.00      None          Never           None
          Falling    2.00      None          Never           None
Jitter-out Rising      5.00      None          Never           None
          Falling    2.00      None          Never           None
Jitter-rt  Rising      6.00      None          Never           None
          Falling    3.00      None          Never           None
Latency-in Rising      30.0     None          Never           None
          Falling    1.00      None          Never           None
Latency-out Rising      30.0     None          Never           None
          Falling    1.00      None          Never           None
Latency-rt Rising      30.0     None          Never           None
```

## Service Assurance Agent Overview

|          |         |      |      |       |      |
|----------|---------|------|------|-------|------|
|          | Falling | 1.00 | None | Never | None |
| Loss-in  | Rising  | 1    | None | Never | None |
|          | Falling | None | None | Never | None |
| Loss-out | Rising  | 1    | None | Never | None |
|          | Falling | None | None | Never | None |
| Loss-rt  | Rising  | 1    | None | Never | None |
|          | Falling | None | None | Never | None |

=====  
\*A:ALA-48>config>saa#

## Configuring Trap Generation

The following shows an example of a ping test.

```
*A:bksim130>config>saa>test>trap-gen# probe-fail-enable
*A:bksim130>config>saa>test>trap-gen# probe-fail-threshold 3
*A:bksim130>config>saa>test>trap-gen# test-completion-enable
*A:bksim130>config>saa>test>trap-gen# test-fail-enable
*A:bksim130>config>saa>test>trap-gen# test-fail-threshold 2

*A:bksim130>config>saa>test>trap-gen# info
-----
      trap-gen
        probe-fail-enable
        probe-fail-threshold 3
        test-completion-enable
        test-fail-enable
        test-fail-threshold 2
      exit
-----
*A:bksim130>config>saa>test>trap-gen#
```

The following shows an example of a trap generation configuration.

```
*A:bksim130# configure saa test mySaaTraceRouteTest1
*A:bksim130>config>saa>test$ type icmp-trace 11.22.33.44

*A:bksim130>config>saa>test$ trap-gen
*A:bksim130>config>saa>test>trap-gen$ probe-fail-enable
MINOR: CLI SAA test with testName=mySaaTraceRouteTest1, ownerName=TiMOS CLI: probe-fail-
enable applies to ping tests only.

*A:bksim130>config>saa>test>trap-gen$ probe-fail-threshold 2
MINOR: CLI SAA test with testName=mySaaTraceRouteTest1, ownerName=TiMOS CLI: probe-fail-
threshold applies to ping tests only.

*A:bksim130>config>saa>test>trap-gen$ test-completion-enable
*A:bksim130>config>saa>test>trap-gen$ test-fail-enable
*A:bksim130>config>saa>test>trap-gen$ test-fail-threshold 2
MINOR: CLI SAA test with testName=mySaaTraceRouteTest1, ownerName=TiMOS CLI: test-fail-
threshold applies to ping tests only.

*A:bksim130>config>saa>test>trap-gen$ info
-----
      trap-gen
        test-completion-enable
        test-fail-enable
      exit
-----
*A:bksim130>config>saa>test>trap-gen#
```



---

## Diagnostics Command Reference

- [OAM Commands on page 175](#)
- [SAA Commands on page 179](#)

---

### OAM Commands

#### Base Operational Commands

##### GLOBAL

- **ping** *[ip-address | dns-name]* [**rapid** | **detail**] [**ttl** *time-to-live*] [**tos** *type-of-service*] [**size** *bytes*] [**pattern** *pattern*] [**source** *ip-address | ipv6-address | dns-name*] [**interval** *seconds*] [**next-hop** *ip-address*] | **{interface** *interface-name*} | **bypass-routing**] [**count** *requests*] [**do-not-fragment**] [**router** *router-instance*] [**timeout** *timeout*]
- **traceroute** *[ip-address | dns-name]* [**ttl** *tll*] [**wait** *milli-seconds*] [**no-dns**][**source** *src-ip-address*] [**tos** *type-of-service*] [**router** *[router-instance]*]
- **oam**
  - **dns** **target-addr** *dns-name* **name-server** *ip-address* [**source** *ip-address*] [**count** *send-count*] [**timeout** *timeout*] [**interval** *interval*] [**record-type** {**ipv4-a-record** | **ipv6-aaaa-record**}]
  - **saa** *test-name* [**owner** *test-owner*] {**start** | **stop**} [**no-accounting**]

#### ATM Diagnostics

##### GLOBAL

- **oam**
  - **atm-ping** *port-id:vpi/vci* [**end-to-end** | **segment**] [**dest** *destination-id*][**send-count** *send-count*][**timeout** *seconds*][**interval** *seconds*]

#### IGMP Snooping

##### GLOBAL

- **oam**
  - **mfib-ping** **service** *service-id* **source** *src-ip* **destination** *mcast-address* [**size** *size*] [**tll** *vc-label-ttl*] [**return-control**] [**interval** *interval*] [**count** *send-count*] [**timeout** *timeout*]

#### LDP Diagnostics

##### GLOBAL

- **oam**
  - **ldp-tretrace** {**prefix** *ip-prefix/mask*} [**max-ttl** *tll-value*] [**max-path** *max-paths*] [**timeout** *timeout*] [**retry-count** *retry-count*] [**fc** *fc-name*] [**profile** *profile*]
- **config**
  - **test-oam**
    - [**no**] **ldp-tretrace**
      - **fc** *fc-name* [**profile** {**in**|**out**}]

- **no fc**
- **path-discovery**
  - **interval** *minutes*
  - **no interval**
  - **max-path** *max-paths*
  - **no max-path**
  - **max-ttl** *ttl-value*
  - **no max-ttl**
  - **policy-statement** *policy-name* [...(up to 5 max)]
  - **no policy-statement**
  - **retry-count** *retry-count*
  - **no retry-count**
  - **timeout** *timeout*
  - **no timeout**
- **path-probing**
  - **interval** *minutes*
  - **no interval**
  - **retry-count** *retry-count*
  - **no retry-count**
  - **timeout** *timeout*
  - **no timeout**
- **[no] shutdown**

## LSP Diagnostics

### GLOBAL

#### — oam

- **lsp-ping** {{[*lsp-name*] [*path path-name*]} | {**prefix** *ip-prefix/mask*}} [**fc** *fc-name*] [**profile** {**in** | **out**}] [**size** *octets*] [**ttl** *label-ttl*] [**send-count** *send-count*] [**timeout** *timeout*] [**interval** *interval*] [**path-destination** *ip-address*] [**interface** *if-name* | **next-hop** *ip-address*][**detail**]
- **lsp-trace** {{[*lsp-name*] [*path path-name*]} | {**prefix** *ip-prefix/mask*}} [**fc** *fc-name*] [**profile** {**in** | **out**}] [**max-fail** *no-response-count*] [**probe-count** *probes-per-hop*] [**size** *octets*][**min-ttl** *min-label-ttl*] [**max-ttl** *max-label-ttl*] [**timeout** *timeout*] [[**interval** *interval*] [**path-destination** *ip-address*] [**interface** *if-name* | **next-hop** *ip-address*]][**detail**]
- **p2mp-lsp-ping** *lsp-name* [**p2mp-instance** *instance-name*] [**s2l-dest-address** *ip-address* [...(up to 5 max)]] [**fc** *fc-name*] [**profile** {**in**|**out**}] [**size** *octets*] [**ttl** *label-ttl*] [**timeout** *timeout*] [**detail**]
- **p2mp-lsp-trace** *lsp-name* **p2mp-instance** *instance-name* **s2l-dest-address** *ip-address* [**fc** *fc-name*] [**profile** {**in** | **out**}] [**size** *octets*] [**max-fail** *no-response-count*] [**probe-count** *probes-per-hop*] [**min-ttl** *min-label-ttl*] [**max-ttl** *max-label-ttl*] [**timeout** *timeout*] [**interval** *interval*] [**detail**]

## SDP Diagnostics

### GLOBAL

#### — oam

- **sdp-mtu** *orig-sdp-id* **size-inc** *start-octets end-octets* [**step** *step-size*] [**timeout** *seconds*] [**interval** *seconds*]
- **sdp-ping** *orig-sdp-id* [**resp-sdp** *resp-sdp-id*] [**fc** *fc-name*] [**profile** {**in** | **out**}] [**timeout** *seconds*] [**interval** *seconds*] [**size** *octets*] [**count** *send-count*]

## Common Service Diagnostics

### GLOBAL

#### — oam

- **ancp** {subscriber *sub-ident-string* | **ancp-string** *ancp-string*} **loopback** [count *count*] [time-out *seconds*] [alarm]
- **ancp subscriber** *sub-ident-string* **loopback** [count *send-count*] [timeout *seconds*] [alarm]
- **svc-ping** {*ip-addr* | *dns-name*} **service** *service-id* [**local-sdp**] [**remote-sdp**]
- **host-connectivity-verify** **service** *service-id* [**sap** *sap-id*]
- **host-connectivity-verify subscriber** *sub-ident-string* [**sla-profile** *sla-profile-name*]
- **dns target-addr** *dns-name* **name-server** *ip-address* [**source** *ip-address*] [count *send-count*] [timeout *timeout*] [interval *interval*]
- **vprn-ping** *service-id* **source** *src-ip* **destination** *ip-address* [**fc** *fc-name*] [**profile** {**in** | **out**}] [size *size*] [ttl *vc-label-ttl*] [**return-control**] [interval *interval*] [count *send-count*] [timeout *time-out*]
- **vprn-trace** *service-id* **source** *src-ip* **destination** *ip-address* [**fc** *fc-name*] [**profile** {**in** | **out**}] [size *size*] [**min-ttl** *vc-label-ttl*] [**max-ttl** *vc-label-ttl*] [**return-control**] [**probe-count** *send-count*] [interval *seconds*] [timeout *timeout*]

## VLL Diagnostics

### GLOBAL

#### — oam

- **vccv-ping** *sdp-id:vc-id* [**src-ip-address** *ip-addr* **dst-ip-address** *ip-addr* **pw-id** *pw-id*] [**reply-mode** {**ip-routed** | **control-channel**}] [**fc** *fc-name*] [**profile** {**in** | **out**}] [size *octets*] [count *send-count*] [timeout *timeout*] [interval *interval*] [ttl *vc-label-ttl*]
- **vccv-trace** *sdp-id:vc-id* [**fc** *fc-name*] [**profile** {**in** | **out**}] [size *octets*] [**reply-mode** *ip-routed|control-channel*] [**probe-count** *probes-per-hop*] [timeout *timeout*] [interval *interval*] [**min-ttl** *min-vc-label-ttl*] [**max-ttl** *max-vc-label-ttl*] [**max-fail** *no-response-count*] [**detail**]

## VPLS MAC Diagnostics

### GLOBAL

#### — oam

- **cpe-ping** **service** *service-id* **destination** *dst-ieee-address* **source** *ip-address* [**source-mac** *ieee-address*] [ttl *vc-label-ttl*] [count *send-count*] [**send-control**] [**return-control**] [interval *interval*]
- **mac-ping** **service** *service-id* **destination** *dst-ieee-address* [**source** *src-ieee-address*] [**fc** *fc-name*] [**profile** **in** | **out**] [size *octets*] [ttl *vc-label-ttl*] [count *send-count*] [**send-control**] [**return-control**] [interval *interval*] [timeout *timeout*]
- **mac-populate** *service-id* **mac** *ieee-address* [**flood**] [**age** *seconds*] [**force**] [**target-sap** *sap-id*] [**send-control**]
- **mac-purge** *service-id* **target** *ieee-address* [**flood**] [**send-control**] [**register**]
- **mac-trace** **service** *service-id* **destination** *ieee-address* [**source** *ieee-address*] [**fc** *fc-name*] [**profile** **in** | **out**] [size *octets*] [**min-ttl** *vc-label-ttl*] [**max-ttl** *vc-label-ttl*] [**probe-count** *send-count*] [**send-control**] [**return-control**] [interval *interval*] [timeout *timeout*]

## Ethernet in the First Mile (EFM) Commands

### GLOBAL

#### — oam

- **efm** *port-id* **local-loopback** {**start** | **stop**}
- **efm** *port-id* **remote-loopback** {**start** | **stop**}

## ETH-CFM OAM Commands

### oam

- **eth-cfm eth-test** *mac-address* **mep** *mep-id* **domain** *md-index* **association** *ma-index* [priority *priority*] [data-length *data-length*]

- **eth-cfm linktrace** *mac-address mep mep-id domain md-index association ma-index* [**tfl** *tfl-value*]
- **eth-cfm loopback** *mac-address mep mep-id domain md-index association ma-index* [**send-count** *send-count*] [**size** *data-size*] [**priority** *priority*]
- **eth-cfm one-way-delay-test** *mac-address mep mep-id domain md-index association ma-index* [**priority** *priority*]
- **eth-cfm two-way-delay-test** *mac-address mep mep-id domain md-index association ma-index* [**priority** *priority*]

## SAA Commands

config

— **saa**

- [no] **test** *test-name* [owner *test-owner*]
  - **accounting-policy** *acct-policy-id*
  - **no accounting-policy**
  - [no] **continuous**
  - **description** *description-string*
  - **no description**
  - [no] **jitter-event** **rising-threshold** *threshold* [**falling-threshold** *threshold*] [*direction*]
  - [no] **latency-event** **rising-threshold** *threshold* [**falling-threshold** *threshold*] [*direction*]
  - [no] **loss-event** **rising-threshold** *threshold* [**falling-threshold** *threshold*] [*direction*]
  - [no] **shutdown**
  - **trap-gen**
    - [no] **probe-fail-enable**
    - [no] **probe-fail-threshold** *0..15*
    - [no] **test-completion-enable**
    - [no] **test-fail-enable**
    - [no] **test-fail-threshold** *0..15*
- [no] **type**
  - **cpe-ping** **service** *service-id* **destination** *ip-address* **source** *ip-address* [**source-mac** *ieee-address*] [**fc** *fc-name*] [**profile** [**in** | **out**]][**ttl** *vc-label-ttl*] [**count** *send-count*] [**send-control**] [**return-control**] [**interval** *interval*]
  - **dns** **target-addr** *dns-name* **name-server** *ip-address* [**source** *ip-address*] [**count** *send-count*] [**timeout** *timeout*] [**interval** *interval*]
  - **eth-cfm-linktrace** *mac-address* **mep** *mep-id* **domain** *md-index* **association** *ma-index* [**ttl** *ttl-value*] [**fc** *fc-name*] [**profile** {**in**|**out**}] [**count** *send-count*] [**timeout** *timeout*] [**interval** *interval*]
  - **eth-cfm-loopback** *mac-address* **mep** *mep-id* **domain** *md-index* **association** *ma-index* [**size** *data-size*] [**fc** *fc-name*] [**profile** {**in**|**out**}] [**count** *send-count*] [**timeout** *timeout*] [**interval** *interval*]
  - **eth-cfm-two-way-delay** *mac-address* **mep** *mep-id* **domain** *md-index* **association** *ma-index* [**fc** *fc-name*] [**profile** {**in**|**out**}] [**count** *send-count*] [**timeout** *timeout*] [**interval** *interval*]
  - **icmp-ping** *mac-address* **mep** *mep-id* **domain** *md-index* **association** *ma-index* [**fc** *fc-name*] [**profile** {**in**|**out**}] [**count** *send-count*] [**timeout** *timeout*] [**interval** *interval*]
  - **icmp-ping** [*ip-address* | *dns-name*] [**rapid** | **detail**] [**ttl** *time-to-live*] [**tos** *type-of-service*] [**size** *bytes*] [**pattern** *pattern*] [**source** *ip-address* | *dns-name*] [**interval** *seconds*] [{**next-hop** *ip-address*}] [{**interface** *interface-name*}] [**bypass-routing**] [**count** *requests*] [**do-not-fragment**] [**router** *router-instance*] [**timeout** *timeout*]
  - **icmp-trace** [*ip-address* | *dns-name*] [**ttl** *time-to-live*] [**wait** *milli-seconds*] [**tos** *type-of-service*] [**source** *ip-address*] [**tos** *type-of-service*] [**router** *router-instance*]
  - **lsp-ping** {{**lsp-name** [**path** *path-name*]}|{**prefix** *ip-prefix/mask*}} [**src-ip-address** *ip-addr*] [**size** *octets*] [**ttl** *label-ttl*] [**timeout** *timeout*] [**interval** *interval*] [**fc** *fc-name*] [**profile** {**in** | **out**}] [**send-count** *send-count*]

- **lsp-trace** *{ {lsp-name [path path-name]} | {prefix ip-prefix/mask} }* [**src-ip-address** *ip-addr*] [**fc** *fc-name* [**profile** {**in** | **out**}]] [**max-fail** *no-response-count*] [**probe-count** *probes-per-hop*] [**size** *octets*] [**min-ttl** *min-label-ttl*] [**max-ttl** *max-label-ttl*] [**timeout** *timeout*] [**interval** *interval*] [**path-destination** *ip-address*] [**interface** *if-name* | **next-hop** *ip-address*]]
- **mac-ping** **service** *service-id* **destination** *ieee-address* [**source** *src-ieee-address*] [**fc** *fc-name* [**profile** {**in** | **out**}]] [**size** *octets*] [**ttl** *vc-label-ttl*] [**count** *send-count*] [**send-control**] [**return-control**] [**interval** *interval*] [**timeout** *timeout*]
- **mac-trace** **service** *service-id* **destination** *ieee-address* [**source** *src-ieee-address*] [**fc** *fc-name* [**profile** {**in** | **out**}]] [**size** *octets*] [**min-ttl** *min-label-ttl*] [**max-ttl** *max-label-ttl*] [**probe-count** *send-count*] [**send-control**] [**return-control**] [**interval** *interval*] [**timeout** *timeout*]
- **sdp-ping** *orig-sdp-id* [**resp-sdp** *resp-sdp-id*] [**fc** *fc-name* [**profile** {**in** | **out**}]] [**size** *octets*] [**count** *send-count*][**timeout** *seconds*] [**interval** *seconds*]
- **vccv-ping** *sdp-id:vc-id* [**src-ip-address** *ip-addr* **dst-ip-address** *ip-addr* **pw-id** *pw-id*][**reply-mode** {**ip-routed** | **control-channel**}][**fc** *fc-name* [**profile** {**in** | **out**}]] [**size** *octets*] [**count** *send-count*][**timeout** *timeout*] [**interval** *interval*][**ttl** *vc-label-ttl*]
- **vccv-trace** *sdp-id:vc-id* [**size** *octets*][**min-ttl** *vc-label-ttl*] [**max-ttl** *vc-label-ttl*][**max-fail** *no-response-count*][**probe-count** *probe-count*][**reply-mode** *ip-routed* | **control-channel**][**timeout** *timeout-value*][**interval** *interval-value*][**fc** *fc-name* [**profile** {**in** | **out**}]] [**detail**]
- **vprn-ping** *service-id* **source** *src-ip* **destination** *dst-ip* [**fc** *fc-name* [**profile** {**in** | **out**}]] [**size** *size*] [**ttl** *vc-label-ttl*] [**count** *send-count*] [**return-control**] [**timeout** *timeout*] [**interval** *seconds*]
- **vprn-trace** *service-id* **source** *src-ip* **destination** *dst-ip* [**fc** *fc-name* [**profile** {**in** | **out**}]] [**size** *size*] [**min-ttl** *vc-label-ttl*] [**max-ttl** *vc-label-ttl*] [**probe-count** *send-count*] [**return-control**] [**timeout** *timeout*] [**interval** *interval*]

## Show Commands

- ```

show
  — eth-cfm
    — association [ma-index] [detail]
    — cfm-stack-table [port [port-id [vlan vlan-id]]] sdp sdp-id[:vc-id]][level 0..7] [direction up | down]
    — cfm-stack-table
    — cfm-stack-table port [port [port-id [vlan vlan-id]]]sdp sdp-id[:vc-id]][level 0..7] [direction up | down]
    — cfm-stack-table sdp [sdp-id[:vc-id]] [level 0..7][direction up | down]
    — cfm-stack-table virtual [service-id] [level 0..7]
    — domain [md-index] [association ma-index | all-associations] [detail]
    — mep mep-id domain md-index association ma-index [loopback] [linktrace]
    — mep mep-id domain md-index association ma-index [remote-mepid mep-id | all-remote-mepids]
    — mep mep-id domain md-index association ma-index eth-test-results [remote-peer mac-address]
    — mep mep-id domain md-index association ma-index one-way-delay-test [remote-peer mac-address]
    — mep mep-id domain md-index association ma-index two-way-delay-test [remote-peer mac-address]
    — mip
  — saa [test-name [owner test-owner]]
  — test-oam
    — ldp-treetrace [prefix ip-prefix/mask] [detail]

```

## Clear Commands

- ```

clear
  — saa [test-name [owner test-owner]]

```

## Debug Commands

- ```

debug
  — oam
    — lsp-ping-trace [tx | rx | both] [raw | detail]
    — no lsp-ping-trace

```



---

## OAM and SAA Commands

---

### Command Hierarchies

---

#### Operational Commands

##### shutdown

<b>Syntax</b>	<b>[no] shutdown</b>
<b>Context</b>	config>saa>test
<b>Description</b>	<p>In order to modify an existing test it must first be shut down. When a test is created it will be in shutdown mode until a <b>no shutdown</b> command is executed.</p> <p>A <b>shutdown</b> can only be performed if a test is not executing at the time the command is entered.</p> <p>Use the <b>no</b> form of the command to set the state of the test to operational.</p>

##### shutdown

<b>Syntax</b>	<b>[no] shutdown</b>
<b>Context</b>	config>test-oam>ldp-treetrace
<b>Description</b>	<p>This command suspends the background process running the LDP ECMP OAM tree discovery and path probing features. The configuration is not deleted.</p> <p>Use the <b>no</b> form of the command to enable the background process.</p>

##### dns

<b>Syntax</b>	<b>dns target-addr dns-name name-server ip-address [source ip-address] [count send-count] [timeout timeout] [interval interval] [record-type {ipv4-a-record   ipv6-aaaa-record}]</b>
<b>Context</b>	oam
<b>Description</b>	This command performs DNS name resolution. If ipv4-a-record is specified, dns-names are queried for A-records only. If ipv6-aaaa-record is specified, AAAA-records are queried first, and if a successful reply is not received, the dns-server is queried for A-records.
<b>Parameters</b>	<b>count send-count</b> — The number of messages to send, expressed as a decimal integer. The <b>send-count</b> parameter is used to override the default number of message requests sent. Each message

request must either timeout or receive a reply before the next message request is sent. The message **interval** value must be expired before the next message request is sent.

**Default** 1

**Values** 1 — 100

*ip-address* — The IP or IPv6 address of the primary DNS server.

ipv4-address - a.b.c.d

ipv6-address - x:x:x:x:x:x:x:x (eight 16-bit pieces)

x:x:x:x:x:d.d.d.d

x - [0..FFFF]H

d - [0..255]D

**timeout** *timeout* — The **timeout** parameter in seconds, expressed as a decimal integer. This value is used to override the default **timeout** value and is the amount of time that the router will wait for a message reply after sending the message request. Upon the expiration of message timeout, the requesting router assumes that the message response will not be received. Any response received after the request times out will be silently discarded.

**Default** 5

**Values** 1 — 120

**interval** *interval* — The **interval** parameter in seconds, expressed as a decimal integer. This parameter is used to override the default request message send interval and defines the minimum amount of time that must expire before the next message request is sent.

If the **interval** is set to 1 second, and the **timeout** value is set to 10 seconds, then the maximum time between message requests is 10 seconds and the minimum is 1 second. This depends upon the receipt of a message reply corresponding to the outstanding message request.

**Default** 1

**Values** 1 — 10

**record-type** — Specifies a record type.

**Values** **ipv4-a-record** — A record specific mapping a host name to an IPv4 address.

**ipv6-aaaa-record** — A record specific to the Internet class that stores a single IPv6 address.

## ping

**Syntax** **ping** [*ip-address* | *dns-name*] [**rapid** | **detail**] [**ttl** *time-to-live*] [**tos** *type-of-service*] [**size** *bytes*] [**pattern** *pattern*] [**source** *ip-address* | *dns-name*] [**interval** *seconds*] [{**next-hop** *ip-*

*address*] | {**interface** *interface-name*} | **bypass-routing**] [**count** *requests*] [**do-not-fragment**] [**router** *router-instance*] [**timeout** *timeout*]

**Context** <GLOBAL>

**Description** This command verifies the reachability of a remote host.

**Parameters** *ip-address* — The far-end IP address to which to send the **svc-ping** request message in dotted decimal notation.

**Values**

ipv4-address:	a.b.c.d
ipv6-address:	x:x:x:x:x:x[-interface] x:x:x:x:x:d.d.d.d[-interface]
x:	[0 — FFFF]H
d:	[0 — 255]D
interface:	32 characters maximum, mandatory for link local addresses

*dns-name* — The DNS name of the far-end device to which to send the **svc-ping** request message, expressed as a character string.

**rapid** — Packets will be generated as fast as possible instead of the default 1 per second.

**detail** — Displays detailed information.

**ttl** *time-to-live* — The TTL value for the MPLS label, expressed as a decimal integer.

**Values** 1 — 128

**tos** *type-of-service* — Specifies the service type.

**Values** 0 — 255

**size** *bytes* — The request packet size in bytes, expressed as a decimal integer.

**Values** 0 — 16384

**pattern** *pattern* — The date portion in a ping packet will be filled with the pattern value specified. If not specified, position info will be filled instead.

**Values** 0 — 65535

**source** *ip-address* — Specifies the IP address to be used.

**Values**

ipv4-address:	a.b.c.d
ipv6-address:	x:x:x:x:x:x: x:x:x:x:x:d.d.d.d
x:	[0 — FFFF]H
d:	[0 — 255]D

**router** *router-instance* — Specifies the router name or service ID.

**Values**

<i>router-name:</i>	Base , management
<i>service-id:</i>	1 — 2147483647

**Default** Base

**bypass-routing** — Specifies whether to send the ping request to a host on a directly attached network

bypassing the routing table.

**interface** *interface-name* — Specifies the name of an IP interface. The name must already exist in the **config>router>interface** context.

**next-hop** *ip-address* — Only displays static routes with the specified next hop IP address.

**Values**     ipv4-address:    a.b.c.d (host bits must be 0)  
               ipv6-address:  x:x:x:x:x:x:x (eight 16-bit pieces)  
                               x:x:x:x:x:d.d.d.d  
                               x:            [0 — FFFF]H  
                               d:            [0 — 255]

**count** *requests* — Specifies the number of times to perform an OAM ping probe operation. Each OAM echo message request must either timeout or receive a reply before the next message request is sent.

**Values**     1 — 100000  
**Default**    5

**do-not-fragment** — Sets the DF (Do Not Fragment) bit in the ICMP ping packet.

**timeout** *seconds* — Overrides the default **timeout** value and is the amount of time that the router will wait for a message reply after sending the message request. Upon the expiration of message timeout, the requesting router assumes that the message response will not be received. A ‘request timeout’ message is displayed by the CLI for each message request sent that expires. Any response received after the request times out will be silently discarded.

**Default**     5  
**Values**     1 — 10

## traceroute

**Syntax**     **traceroute** [*ip-address* | *dns-name*] [**t***tl ttl*] [**w***ait milli-seconds*] [**n***o-dns*] [**s***ource ip-address*] [**t***os type-of-service*] [**r***outer router-instance*]

**Context**    oam

**Description**   The TCP/IP traceroute utility determines the route to a destination address. DNS lookups of the responding hosts is enabled by default.

```
*A:ALA-1# traceroute 192.168.xx.xx4
traceroute to 192.168.xx.xx4, 30 hops max, 40 byte packets
 1 192.168.xx.xx4 0.000 ms 0.000 ms 0.000 ms
*A:ALA-1#
```

**Parameters**   *ip-address* — The far-end IP address to which to send the traceroute request message in dotted decimal notation.

**Values**     ipv4-address :    a.b.c.d  
               ipv6-address:  x:x:x:x:x:x:x  
                               x:x:x:x:x:d.d.d.d

x: [0 — FFFF]H  
 d: [0 — 255]D

**dns-name** — The DNS name of the far-end device to which to send the traceroute request message, expressed as a character string.

**tll** *tll* — The maximum Time-To-Live (TTL) value to include in the traceroute request, expressed as a decimal integer.

**Values** 1 — 255

**wait** *milliseconds* — The time in milliseconds to wait for a response to a probe, expressed as a decimal integer.

**Default** 5000

**Values** 1 — 60000

**no-dns** — When the **no-dns** keyword is specified, DNS lookups of the responding hosts will not be performed, only the IP addresses will be printed.

**Default** DNS lookups are performed

**source** *ip-address* — The source IP address to use as the source of the probe packets in dotted decimal notation. If the IP address is not one of the device's interfaces, an error is returned.

**tos** *type-of-service* — The type-of-service (TOS) bits in the IP header of the probe packets, expressed as a decimal integer.

**Values** 0 — 255

**router** *router-name* — Specify the alphanumeric character string up to 32 characters.

**Default** Base

**router** *service-id* — The unique service identification number identifying the service in the service domain. This ID must be unique to this service and may not be used for any other service of any type. The *service-id* must be the same number used for every 7750 SR on which this service is defined.

**Values** 1 — 2147483647

## p2mp-lsp-ping

**Syntax** **p2mp-lsp-ping** *lsp-name* [**p2mp-instance** *instance-name* [**s2l-dest-address** *ip-address* [...(up to 5 max)]]] [**fc** *fc-name* [**profile** {**in** | **out**}]] [**size** *octets*] [**tll** *label-ttl*] [**timeout** *timeout*] [**detail**]

**Context** oam

**Description** This command performs in-band connectivity test for an RSVP P2MP LSP. The echo request message is sent on the active P2MP instance and is replicated in the data path over all branches of the P2MP LSP instance. By default, all egress LER nodes which are leaves of the P2MP LSP instance will reply to the echo request message.

The user can reduce the scope of the echo reply messages by explicitly entering a list of addresses for the egress LER nodes that are required to reply. A maximum of 5 addresses can be specified in a single run of the **p2mp-lsp-ping** command. A LER node is able to parse the list of egress LER addresses and if its address is included, it will reply with an echo reply message.

The output of the command without the detail option provides a high-level summary of error codes and/or success codes received. The output of the command with the detail option shows a line for each replying node as in the output of the LSP ping for a P2P LSP.

The display will be delayed until all responses are received or the timer configured in the timeout parameter expired. No other CLI commands can be entered while waiting for the display. A ^C will abort the ping operation.

### Parameters

**lsp-name** — Name that identifies an P2MP LSP to ping. The LSP name can be up to 32 characters long.

**p2mp-instance** *instance-name* — Configures the name, up to 32 characters long, of the specific instance of the P2MP LSP to send the echo request.

**s2l-dest-addr** *ip-address* [*ip-address*...up to 5] — Specifies the list of egress LER system addresses which are required to reply to the LSP ping echo request message.

**fc** *fc-name* — The fc parameter is used to indicate the forwarding class of the MPLS echo request packets. The actual forwarding class encoding is controlled by the network egress LSP-EXP mappings.

The LSP-EXP mappings on the receive network interface controls the mapping back to the internal forwarding class used by the far-end router that receives the message request. The egress mappings of the egress network interface on the far-end far-end controls the forwarding class markings on the return reply message.

The LSP-EXP mappings on the receive network interface controls the mapping of the message reply back at the originating far-end.

**Default**     be

**Values**     be, l2, af, l1, h2, ef, h1, nc

**profile** {in | out} — The profile of the LSP ping echo request message.

**Default**     out

**size** *octets* — The MPLS echo request packet size in octets, expressed as a decimal integer. The request payload is padded with zeroes to the specified size.

**Default**     128 octets. The system sends the minimum packet size for an RSVP P2MP LSP.

**Values**     128 — 65535

**ttl** *label-ttl* — The TTL value for the MPLS label, expressed as a decimal integer.

**Default**     255

**Values**     1 — 255

**timeout** *timeout* — The timeout parameter in seconds, expressed as a decimal integer. This value is used to override the default timeout value and is the amount of time that the router will wait for an echo reply message from all leaves of the P2MP LSP after sending the message request message. Upon the expiration of message timeout, the requesting router assumes that the missing

replies will not be received. Any echo reply message received after the request times out will be silently discarded.

**Default** 10 seconds

**Values** 1 — 120

## p2mp-lsp-trace

<b>Syntax</b>	<b>p2mp-lsp-trace</b> <i>lsp-name</i> <b>p2mp-instance</b> <i>instance-name</i> <b>s2l-dest-address</b> <i>ip-address</i> [ <b>fc</b> <i>fc-name</i> [ <b>profile</b> { <b>in</b>   <b>out</b> }]] [ <b>size</b> <i>octets</i> ] [ <b>max-fail</b> <i>no-response-count</i> ] [ <b>probe-count</b> <i>probes-per-hop</i> ] [ <b>min-ttl</b> <i>min-label-ttl</i> ] [ <b>max-ttl</b> <i>max-label-ttl</i> ] [ <b>timeout</b> <i>timeout</i> ] [ <b>interval</b> <i>interval</i> ] [ <b>detail</b> ]
<b>Context</b>	oam
<b>Description</b>	<p>This command discovers and displays the hop-by-hop path for a source-to-leaf (S2L) sub-LSP of an RSVP P2MP LSP.</p> <p>The LSP trace capability allows the user to trace the path of a single S2L path of a P2MP LSP. Its operation is similar to that of the p2mp-lsp-ping but the sender of the echo reply request message includes the downstream mapping TLV to request the downstream branch information from a branch LSR or bud LSR. The branch LSR or bud LSR will then also include the downstream mapping TLV to report the information about the downstream branches of the P2MP LSP. An egress LER must not include this TLV in the echo response message.</p> <p>The parameter probe-count operates in the same way as in LSP Trace on a P2P LSP. It represents the maximum number of probes sent per TTL value before giving up on receiving the echo reply message. If a response is received from the traced node before reaching maximum number of probes, then no more probes are sent for the same TTL. The sender of the echo request then increments the TTL and uses the information it received in the downstream mapping TLV to start sending probes to the node downstream of the last node which replied. This continues until the egress LER for the traced S2L path replied.</p> <p>Similar to p2mp-lsp-ping, an LSP trace probe results on all egress LER nodes eventually receiving the echo request message but only the traced egress LER node will reply to the last probe.</p> <p>Also any branch LSR node or bud LSR node in the P2MP LSP tree may receive a copy of the echo request message with the TTL in the outer label expiring at this node. However, only a branch LSR or bud LSR which has a downstream branch over which the traced egress LER is reachable will respond.</p> <p>When a branch LSR or bud LSR responds, it sets the B-flag in the downstream mapping TLV to indicate to the sender of the echo request message it has other branches for this LSP. A bud LSR will also set the E-flag in the downstream mapping TLV to indicate to the sender of the echo request message that it is also an egress LER for the P2MP LSP when the traced egress is reachable via a downstream branch. In this case, the return code must correspond to the LSR role and must code #8: “Label switched at stack-depth &lt;RSC&gt;”</p>
<b>Parameters</b>	<p><i>lsp-name</i> — Name that identifies an P2MP LSP, to 32 characters long, to ping.</p> <p><b>p2mp-instance</b> <i>instance-name</i> — configures the name, up to 32 characters long, of the specific instance of the P2MP LSP to send the echo request.</p>

**s2l-dest-addr** *ip-address* — Specifies the egress LER system address of the S2L sub-LSP path which is being traced.

**fc fc-name** — The **fc** parameter is used to indicate the forwarding class of the MPLS echo request packets. The actual forwarding class encoding is controlled by the network egress LSP-EXP mappings.

The LSP-EXP mappings on the receive network interface controls the mapping back to the internal forwarding class used by the far-end node that receives the message request. The egress mappings of the egress network interface on the far-end node controls the forwarding class markings on the return reply message.

The LSP-EXP mappings on the receive network interface controls the mapping of the message reply back at the originating node.

**Default**     be

**Values**     be, l2, af, l1, h2, ef, h1, nc

**profile {in | out}** — The profile of the LSP trace echo request message.

**Default**     out

**size** *octets* — The MPLS echo request packet size in octets, expressed as a decimal integer. The request payload is padded with zeroes to the specified size.

**Default**     128 octets. The system sends the minimum packet size for an RSVP P2MP LSP.

**Values**     128 — 65535

**max-fail** *no-response-count* — The maximum number of consecutive MPLS echo requests, expressed as a decimal integer that do not receive a reply before the trace operation fails for a given TTL.

**Default**     5

**Values**     1 — 255

**min-ttl** *min-label-ttl* — The minimum TTL value in the MPLS label for the LSP trace test, expressed as a decimal integer.

**Default**     1

**Values**     1 — 255

**max-ttl** *max-label-ttl* — the maximum TTL value in the MPLS label for the LSP trace test, expressed as a decimal integer.

**Default**     30

**Values**     1-255

**probe-count** *probes-per-hop* — The number of LSP trace echo request messages to send per TTL value.

**Default**     1

**Values**     1 — 10

**timeout** *timeout* — The timeout parameter in seconds, expressed as a decimal integer. This value is used to override the default timeout value and is the amount of time that the router will wait for

an echo reply message from all leaves of the P2MP LSP after sending the message request message. Upon the expiration of message timeout, the requesting router assumes that the missing replies will not be received. Any echo reply message received after the request times out will be silently discarded.

**Default** 3 seconds

**Values** 1 — 60

**interval** *interval* — The interval parameter in seconds, expressed as a decimal integer. This parameter is used to override the default echo request message send interval and defines the minimum amount of time that must expire before the next echo request message is sent.

If the interval is set to 1 second, and the timeout value is set to 10 seconds, then the maximum time between message requests is 10 seconds and the minimum is 1 second. This depends upon the receipt of an echo reply message corresponding to the outstanding message request.

**Default** 1

**Values** 1 — 10

## ATM Diagnostics

### atm-ping

<b>Syntax</b>	<b>atm-ping</b> <i>port-id</i> : <i>vpi/vci</i> [ <b>end-to-end</b>   <b>segment</b> ] [ <b>dest</b> <i>destination-id</i> ] [ <b>send-count</b> <i>send-count</i> ] [ <b>timeout</b> <i>timeout</i> ] [ <b>interval</b> <i>seconds</i> ]															
<b>Context</b>	<GLOBAL>															
<b>Description</b>	This command tests ATM path connectivity and round trip time on an ATM VCC.															
<b>Parameters</b>	<i>port-id</i> : <i>vpi/vci</i> — Specifies the ID of the access port of the target VC. This parameter is required.															
	<b>Values</b>	<table> <tr> <td>port-id</td> <td><i>slot/mda/port</i></td> </tr> <tr> <td>aps-id</td> <td><i>aps-group-id</i></td> </tr> <tr> <td></td> <td>aps keyword</td> </tr> <tr> <td></td> <td>group-id 1 — 64</td> </tr> <tr> <td>vpi</td> <td>0 — 4095 (NNI)</td> </tr> <tr> <td></td> <td>0 — 255 (UNI)</td> </tr> <tr> <td>vci</td> <td>1, 2, 5 — 65535</td> </tr> </table>	port-id	<i>slot/mda/port</i>	aps-id	<i>aps-group-id</i>		aps keyword		group-id 1 — 64	vpi	0 — 4095 (NNI)		0 — 255 (UNI)	vci	1, 2, 5 — 65535
port-id	<i>slot/mda/port</i>															
aps-id	<i>aps-group-id</i>															
	aps keyword															
	group-id 1 — 64															
vpi	0 — 4095 (NNI)															
	0 — 255 (UNI)															
vci	1, 2, 5 — 65535															
	<b>end-to-end</b>   <b>segment</b>	— Specifies whether the ATM OAM loopback cell is destined to the first segment point in the line direction or the PVCC's connection endpoint.														
	<b>Default</b>	end-to-end														
	<b>dest</b> <i>destination-id</i>	— Defines the LLID field in an OAM loopback cell. If set to all 1s, only the connection end (end-to-end ping) or segment end (segment ping) will respond to the ping. If the 'segment' parameter is specified and 'dest' is set to a specific destination, only the destination will respond to the ping.														
	<b>Values</b>	A 16 byte octet string, with each octet separated by a colon, if not specified the value of all 0x11 will be used.														
	<b>send-count</b> <i>send-count</i>	— The number of messages to send, expressed as a decimal integer. The <b>send-count</b> parameter is used to override the default number of message requests sent. Each message request must either timeout or receive a reply before the next message request is sent. The message <b>interval</b> value must be expired before the next message request is sent.														
	<b>Default</b>	1														
	<b>Values</b>	1 — 100														
	<b>timeout</b> <i>timeout</i>	— The <b>timeout</b> parameter in seconds, expressed as a decimal integer. This value is used to override the default timeout value and is the amount of time that the router will wait for a message reply after sending the message request. Upon the expiration of message timeout, the requesting router assumes that the message response will not be received. Any response received after the request times out will be silently discarded.														
	<b>Default</b>	5														
	<b>Values</b>	1 — 10														

**interval** *interval* — The **interval** parameter in seconds, expressed as a decimal integer. This parameter is used to override the default request message send interval and defines the minimum amount of time that must expire before the next message request is sent.

If the **interval** is set to 1 second, and the **timeout** value is set to 10 seconds, then the maximum time between message requests is 10 seconds and the minimum is 1 second. This depends upon the receipt of a message reply corresponding to the outstanding message request.

**Default** 1

**Values** 1 — 10

---

## Service Diagnostics

### ancp

<b>Syntax</b>	<b>ancp</b> { <b>subscriber</b> <i>sub-ident-string</i>   <b>ancp-string</b> <i>ancp-string</i> } <b>loopback</b> [ <b>count</b> <i>count</i> ] [ <b>timeout</b> <i>seconds</i> ] [ <b>alarm</b> ] <b>ancp subscriber</b> <i>sub-ident-string</i> <b>loopback</b> [ <b>count</b> <i>send-count</i> ] [ <b>timeout</b> <i>seconds</i> ] [ <b>alarm</b> ]
<b>Context</b>	<GLOBAL>
<b>Description</b>	This command sends an OAM request to the access node. ANCP can be used to send OAM messages to the access node. The access node must be able to accept these messages and will signal such support by the capability negotiations. If the operator attempts to send an OAM command to an access node that does not support such command the operation results in an error.
<b>Parameters</b>	<p><b>subscriber</b> <i>sub-ident-string</i> — Specifies an existing subscriber-id. The node will use the ancp-string associated with the provided subscriber-id to identify the circuit.</p> <p><b>ancp-string</b> <i>ancp-string</i> — Specifies an existing ANCP string.</p> <p><b>count</b> <i>send-count</i> — Specifies the number of messages the access node will use to test the circuit. If omitted, the number will be determined by the access node via local policy. 1 — 32</p> <p><b>timeout</b> <i>seconds</i> — Specifies how long the controlling node will wait for a result. 0 — 300</p> <p><b>alarm</b> — Specifies that the CLI the result will be returned to the CLI and a trap will be issued to indicate the test finished. If the flag is used through SNMP the results will be available in the results MIB and after the node sent the trap to indicate the results are ready.</p> <p><b>loopback</b> — Sends an OAM loopback test request to the access node</p>

### sdp-mtu

<b>Syntax</b>	<b>sdp-mtu</b> <i>orig-sdp-id</i> <b>size-inc</b> <i>start-octets end-octets</i> [ <b>step</b> <i>step-size</i> ] [ <b>timeout</b> <i>seconds</i> ] [ <b>interval</b> <i>seconds</i> ]
<b>Context</b>	oam
<b>Description</b>	Performs MTU Path tests on an SDP to determine the largest path-mtu supported on an SDP. The <b>size-inc</b> parameter can be used to easily determine the <b>path-mtu</b> of a given SDP-ID. The forwarding class is assumed to be Best-Effort Out-of-Profile. The message reply is returned with IP/GRE encapsulation from the far-end 7750 SR. OAM request messages sent within an IP/GRE SDP must have the 'DF' IP header bit set to 1 to prevent message fragmentation. To terminate an <b>sdp-mtu</b> in progress, use the CLI break sequence <Ctrl-C>.

**Special Cases** **SDP Path MTU Tests** — SDP Path MTU tests can be performed using the **sdp-mtu size-inc** keyword to easily determine the **path-mtu** of a given SDP-ID. The forwarding class is assumed to be Best-Effort Out-of-Profile. The message reply is returned with IP/GRE encapsulation from the far-end 7750 SR.

With each OAM Echo Request sent using the **size-inc** parameter, a response line is displayed as message output. The path MTU test displays incrementing packet sizes, the number sent at each size until a reply is received and the response message.

As the request message is sent, its size value is displayed followed by a period for each request sent of that size. Up to three requests will be sent unless a valid response is received for one of the requests at that size. Once a response is received, the next size message is sent.

The response message indicates the result of the message request.

After the last reply has been received or response timeout, the maximum size message replied to indicates the largest size OAM Request message that received a valid reply.

**Parameters** *orig-sdp-id* — The *sdp-id* to be used by **sdp-ping**, expressed as a decimal integer. The far-end address of the specified *sdp-id* is the expected *responder-id* within each reply received. The specified *sdp-id* defines the encapsulation of the SDP tunnel encapsulation used to reach the far end. This can be IP/GRE or MPLS. If *orig-sdp-id* is invalid or administratively down or unavailable for some reason, the SDP echo request message is not sent and an appropriate error message is displayed (once the **interval** timer expires, sdp-ping will attempt to send the next request if required).

**Values** 1 — 17407

**size-inc** *start-octets end-octets* — Indicates an incremental path MTU test will be performed with by sending a series of message requests with increasing MTU sizes. The *start-octets* and *end-octets* parameters are described below.

*start-octets* — The beginning size in octets of the first message sent for an incremental MTU test, expressed as a decimal integer.

**Values** 40 — 9198

*end-octets* — The ending size in octets of the last message sent for an incremental MTU test, expressed as a decimal integer. The specified value must be greater than *start-octets*.

**Values** 40 — 9198

**step** *step-size* — The number of octets to increment the message size request for each message sent for an incremental MTU test, expressed as a decimal integer. The next size message will not be sent until a reply is received or three messages have timed out at the current size.

If the incremented size exceeds the *end-octets* value, no more messages will be sent.

**Default** 32

**Values** 1 — 512

**timeout** *seconds* — The **timeout** parameter in seconds, expressed as a decimal integer. This value is used to override the default **timeout** value and is the amount of time that the router will wait for a message reply after sending the message request. Upon the expiration of message timeout, the requesting router assumes that the message response will not be received. A ‘request timeout’ message is displayed by the CLI for each message request sent that expires. Any response received after the request times out will be silently discarded.

**Default** 5

**Values** 1 — 10

**interval seconds** — The **interval** parameter in seconds, expressed as a decimal integer. This parameter is used to override the default request message send interval and defines the minimum amount of time that must expire before the next message request is sent.

If the **interval** is set to 1 second, and the **timeout** value is set to 10 seconds, then the maximum time between message requests is 10 seconds and the minimum is 1 second. This depends upon the receipt of a message reply corresponding to the outstanding message request.

**Default** 1

**Values** 1 — 10

**Output Sample SDP MTU Path Test Sample Output**

```
*A:Dut-A# oam sdp-mtu 1201 size-inc 512 3072 step 256
Size      Sent      Response
-----
512       .         Success
768       .         Success
1024      .         Success
1280      .         Success
1536      .         Success
1792      .         Success
2048      .         Success
2304      .         Success
2560      .         Success
2816      .         Success
3072      .         Success

Maximum Response Size: 3072
*A:Dut-A#
```

## svc-ping

**Syntax** **svc-ping** *ip-address* [**service** *service-id*] [**local-sdp**] [**remote-sdp**]

**Context** <GLOBAL>

**Description** Tests a service ID for correct and consistent provisioning between two service end points.

The **svc-ping** command accepts a far-end IP address and a *service-id* for local and remote service testing. The following information can be determined from **svc-ping**:

1. Local and remote service existence
2. Local and remote service state
3. Local and remote service type correlation
4. Local and remote customer association
5. Local and remote service-to-SDP bindings and state
6. Local and remote ingress and egress service label association

Unlike **sdp-ping**, only a single message will be sent per command; no count nor interval parameter is supported and round trip time is not calculated. A timeout value of 10 seconds is used before failing the request. The forwarding class is assumed to be Best-Effort Out-of-Profile

If no request is sent or a reply is not received, all remote information will be shown as N/A.

To terminate a **svc-ping** in progress, use the CLI break sequence <Ctrl-C>.

Upon request timeout, message response, request termination, or request error the following local and remote information will be displayed. Local and remote information will be dependent upon service existence and reception of reply.

Field	Description	Values
Request Result	The result of the <b>svc-ping</b> request message.	Sent - Request Timeout Sent - Request Terminated Sent - Reply Received Not Sent - Non-Existent Service-ID Not Sent - Non-Existent SDP for Service Not Sent - SDP For Service Down Not Sent - Non-existent Service Egress Label
Service-ID	The ID of the service being tested.	<i>service-id</i>
Local Service Type	The type of service being tested. If <i>service-id</i> does not exist locally, N/A is displayed.	Epipes, Ipipes, Fpipes, Apipes TLS IES Mirror-Dest N/A
Local Service Admin State	The local administrative state of <i>service-id</i> . If the service does not exist locally, the administrative state will be Non-Existent.	Admin-Up Admin-Down Non-Existent
Local Service Oper State	The local operational state of <i>service-id</i> . If the service does not exist locally, the state will be N/A.	Oper-Up Oper-Down N/A

Field	Description	Values (Continued)
Remote Service Type	The remote type of service being tested. If <i>service-id</i> does not exist remotely, N/A is displayed.	Epipe, Ipipe, Fpipe, Apipe TLS IES Mirror-Dest N/A
Remote Service Admin State	The remote administrative state of <i>service-id</i> . If the service does not exist remotely, the administrative state is Non-Existent.	Up Down Non-Existent
Local Service MTU	The local <b>service-mtu</b> for <i>service-id</i> . If the service does not exist, N/A is displayed.	<i>service-mtu</i> N/A
Remote Service MTU	The remote <b>service-mtu</b> for <i>service-id</i> . If the service does not exist remotely, N/A is displayed.	<i>remote-service-mtu</i> N/A
Local Customer ID	The local <i>customer-id</i> associated with <i>service-id</i> . If the service does not exist locally, N/A is displayed.	<i>customer-id</i> N/A
Remote Customer ID	The remote <i>customer-id</i> associated with <i>service-id</i> . If the service does not exist remotely, N/A is displayed.	<i>customer-id</i> N/A
Local Service IP Address	The local system IP address used to terminate remotely configured SDP-ID (as the <b>far-end</b> address). If an IP interface has not been configured to be the system IP address, N/A is displayed.	<i>system-ip-address</i> N/A
Local Service IP Interface Name	The name of the local system IP interface. If the local system IP interface has not been created, N/A is displayed.	<i>system-interface-name</i> N/A
Local Service IP Interface State	The state of the local system IP interface. If the local system IP interface has not been created, Non-Existent is displayed.	Up Down Non-Existent
Expected Far-end Address	The expected IP address for the remote system IP interface. This must be the <b>far-end</b> address entered for the <b>svc-ping</b> command.	<i>orig-sdp-far-end-addr</i> <i>dest-ip-addr</i> N/A
Actual Far-end Address	The returned remote IP address. If a response is not received, the displayed value is N/A. If the far-end service IP interface is down or non-existent, a message reply is not expected. <b>sdp-ping</b> should also fail.	<i>resp-ip-addr</i> N/A

Field	Description	Values (Continued)
Responders Expected Far-end Address	The expected source of the originator's <i>sdp-id</i> from the perspective of the remote router terminating the <i>sdp-id</i> . If the far-end cannot detect the expected source of the ingress <i>sdp-id</i> or the request is transmitted outside the <i>sdp-id</i> , N/A is displayed.	<i>resp-rec-tunnel-far-end-address</i> N/A
Originating SDP-ID	The <i>sdp-id</i> used to reach the <b>far-end</b> IP address if <b>sdp-path</b> is defined. The originating <i>sdp-id</i> must be bound to the <i>service-id</i> and terminate on the <b>far-end</b> IP address. If an appropriate originating <i>sdp-id</i> is not found, Non-Existent is displayed.	orig-sdp-id Non-Existent
Originating SDP-ID Path Used	Whether the Originating router used the originating <i>sdp-id</i> to send the <b>svc-ping</b> request. If a valid originating <i>sdp-id</i> is found, operational and has a valid egress service label, the originating router should use the <i>sdp-id</i> as the requesting path if <b>sdp-path</b> has been defined. If the originating router uses the originating <i>sdp-id</i> as the request path, Yes is displayed. If the originating router does not use the originating <i>sdp-id</i> as the request path, No is displayed. If the originating <i>sdp-id</i> is non-existent, N/A is displayed.	Yes No N/A
Originating SDP-ID Administrative State	The local administrative state of the originating <i>sdp-id</i> . If the <i>sdp-id</i> has been shutdown, Admin-Down is displayed. If the originating <i>sdp-id</i> is in the no shutdown state, Admin-Up is displayed. If an originating <i>sdp-id</i> is not found, N/A is displayed.	Admin-Up Admin-Up N/A
Originating SDP-ID Operating State	The local operational state of the originating <i>sdp-id</i> . If an originating <i>sdp-id</i> is not found, N/A is displayed.	Oper-Up Oper-Down N/A
Originating SDP-ID Binding Admin State	The local administrative state of the originating <i>sdp-ids</i> binding to <i>service-id</i> . If an <i>sdp-id</i> is not bound to the service, N/A is displayed.	Admin-Up Admin-Up N/A
Originating SDP-ID Binding Oper State	The local operational state of the originating <i>sdp-ids</i> binding to <i>service-id</i> . If an <i>sdp-id</i> is not bound to the service, N/A is displayed.	Oper-Up Oper-Down N/A
Responding SDP-ID	The <i>sdp-id</i> used by the far end to respond to the <b>svc-ping</b> request. If the request was received without the <b>sdp-path</b> parameter, the responding router will not use an <i>sdp-id</i> as the return path, but the appropriate responding <i>sdp-id</i> will be displayed. If a valid <i>sdp-id</i> return path is not found to the originating router that is bound to the <i>service-id</i> , Non-Existent is displayed.	<i>resp-sdp-id</i> Non-Existent

Field	Description	Values (Continued)
Responding SDP-ID Path Used	Whether the responding router used the responding <i>sdp-id</i> to respond to the <b>svc-ping</b> request. If the request was received via the originating <i>sdp-id</i> and a valid return <i>sdp-id</i> is found, operational and has a valid egress service label, the far-end router should use the <i>sdp-id</i> as the return <i>sdp-id</i> . If the far end uses the responding <i>sdp-id</i> as the return path, Yes is displayed. If the far end does not use the responding <i>sdp-id</i> as the return path, No is displayed. If the responding <i>sdp-id</i> is non-existent, N/A is displayed.	Yes No N/A
Responding SDP-ID Administrative State	The administrative state of the far-end <i>sdp-id</i> associated with the return path for <i>service-id</i> . When a return path is administratively down, Admin-Down is displayed. If the return <i>sdp-id</i> is administratively up, Admin-Up is displayed. If the responding <i>sdp-id</i> is non-existent, N/A is displayed.	Admin-Up Admin-Up N/A
Responding SDP-ID Operational State	The operational state of the far-end <i>sdp-id</i> associated with the return path for <i>service-id</i> . When a return path is operationally down, Oper-Down is displayed. If the return <i>sdp-id</i> is operationally up, Oper-Up is displayed. If the responding <i>sdp-id</i> is non-existent, N/A is displayed.	Oper-Up Oper-Down N/A
Responding SDP-ID Binding Admin State	The local administrative state of the responder's <i>sdp-id</i> binding to <i>service-id</i> . If an <i>sdp-id</i> is not bound to the service, N/A is displayed.	Admin-Up Admin-Down N/A
Responding SDP-ID Binding Oper State	The local operational state of the responder's <i>sdp-id</i> binding to <i>service-id</i> . If an <i>sdp-id</i> is not bound to the service, N/A is displayed.	Oper-Up Oper-Down N/A
Originating VC-ID	The originator's VC-ID associated with the <i>sdp-id</i> to the far-end address that is bound to <i>service-id</i> . If the <i>sdp-id</i> signaling is off, <i>originator-vc-id</i> is 0. If the <i>originator-vc-id</i> does not exist, N/A is displayed.	<i>originator-vc-id</i> N/A
Responding VC-ID	The responder's VC-ID associated with the <i>sdp-id</i> to <i>originator-id</i> that is bound to <i>service-id</i> . If the <i>sdp-id</i> signaling is off or the service binding to <i>sdp-id</i> does not exist, <i>responder-vc-id</i> is 0. If a response is not received, N/A is displayed.	<i>responder-vc-id</i> N/A
Originating Egress Service Label	The originating service label (VC-Label) associated with the <i>service-id</i> for the originating <i>sdp-id</i> . If <i>service-id</i> does not exist locally, N/A is displayed. If <i>service-id</i> exists, but the egress service label has not been assigned, Non-Existent is displayed.	<i>egress-vc-label</i> N/A Non-Existent

Field	Description	Values (Continued)
Originating Egress Service Label Source	The originating egress service label source. If the displayed egress service label is manually defined, Manual is displayed. If the egress service label is dynamically signaled, Signaled is displayed. If the <i>service-id</i> does not exist or the egress service label is non-existent, N/A is displayed.	Manual Signaled N/A
Originating Egress Service Label State	The originating egress service label state. If the originating router considers the displayed egress service label operational, Up is displayed. If the originating router considers the egress service label inoperative, Down is displayed. If the <i>service-id</i> does not exist or the egress service label is non-existent, N/A is displayed.	Up Down N/A
Responding Service Label	The actual responding service label in use by the far-end router for this <i>service-id</i> to the originating router. If <i>service-id</i> does not exist in the remote router, N/A is displayed. If <i>service-id</i> does exist remotely but the remote egress service label has not been assigned, Non-Existent is displayed.	<i>rec-vc-label</i> N/A Non-Existent
Responding Egress Service Label Source	The responder's egress service label source. If the responder's egress service label is manually defined, Manual is displayed. If the responder's egress service label is dynamically signaled, Signaled is displayed. If the <i>service-id</i> does not exist on the responder or the responder's egress service label is non-existent, N/A is displayed.	Manual Signaled N/A
Responding Service Label State	The responding egress service label state. If the responding router considers its egress service label operational, Up is displayed. If the responding router considers its egress service label inoperative, Down is displayed. If the <i>service-id</i> does not exist or the responder's egress service label is non-existent, N/A is displayed.	Up Down N/A
Expected Ingress Service Label	The locally assigned ingress service label. This is the service label that the far-end is expected to use for <i>service-id</i> when sending to the originating router. If <i>service-id</i> does not exist locally, N/A is displayed. If <i>service-id</i> exists but an ingress service label has not been assigned, Non-Existent is displayed.	<i>ingress-vc-label</i> N/A Non-Existent
Expected Ingress Label Source	The originator's ingress service label source. If the originator's ingress service label is manually defined, Manual is displayed. If the originator's ingress service label is dynamically signaled, Signaled is displayed. If the <i>service-id</i> does not exist on the originator or the originators ingress service label has not been assigned, N/A is displayed.	Manual Signaled N/A

Field	Description	Values (Continued)
Expected Ingress Service Label State	The originator's ingress service label state. If the originating router considers its ingress service label operational, Up is displayed. If the originating router considers its ingress service label inoperative, Down is displayed. If the <i>service-id</i> does not exist locally, N/A is displayed.	Up Down N/A
Responders Ingress Service Label	The assigned ingress service label on the remote router. This is the service label that the far end is expecting to receive for <i>service-id</i> when sending to the originating router. If <i>service-id</i> does not exist in the remote router, N/A is displayed. If <i>service-id</i> exists, but an ingress service label has not been assigned in the remote router, Non-Existent is displayed.	<i>resp-ingress-vc-label</i> N/A Non-Existent
Responders Ingress Label Source	The assigned ingress service label source on the remote router. If the ingress service label is manually defined on the remote router, Manual is displayed. If the ingress service label is dynamically signaled on the remote router, Signaled is displayed. If the <i>service-id</i> does not exist on the remote router, N/A is displayed.	Manual Signaled N/A
Responders Ingress Service Label State	The assigned ingress service label state on the remote router. If the remote router considers its ingress service label operational, Up is displayed. If the remote router considers its ingress service label inoperative, Down is displayed. If the <i>service-id</i> does not exist on the remote router or the ingress service label has not been assigned on the remote router, N/A is displayed.	Up Down N/A

**Parameters** *ip-address* — The far-end IP address to which to send the **svc-ping** request message in dotted decimal notation.

**service** *service-id* — The service ID of the service being tested must be indicated with this parameter. The service ID need not exist on the local 7750 SR to receive a reply message.

**Values** 1 — 2147483647

**local-sdp** — Specifies the **svc-ping** request message should be sent using the same service tunnel encapsulation labeling as service traffic. If **local-sdp** is specified, the command attempts to use an egress *sdp-id* bound to the service with the specified **far-end** IP address with the VC-Label for the service. The far-end address of the specified *sdp-id* is the expected *responder-id* within the reply received. The *sdp-id* defines the encapsulation of the SDP tunnel encapsulation used to reach the far end; this can be IP/GRE or MPLS. On originator egress, the service-ID must have an associated VC-Label to reach the far-end address of the *sdp-id* and the *sdp-id* must be operational for the message to be sent.

If **local-sdp** is not specified, the **svc-ping** request message is sent with GRE encapsulation with the OAM label.

The following table indicates whether a message is sent and how the message is encapsulated based on the state of the service ID.

Local Service State	local-sdp Not Specified		local-sdp Specified	
	Message Sent	Message Encapsulation	Message Sent	Message Encapsulation
Invalid Local Service	Yes	Generic IP/GRE OAM (PLP)	No	None
No Valid SDP-ID Bound	Yes	Generic IP/GRE OAM (PLP)	No	None
SDP-ID Valid But Down	Yes	Generic IP/GRE OAM (PLP)	No	None
SDP-ID Valid and Up, But No Service Label	Yes	Generic IP/GRE OAM (PLP)	No	None
SDP-ID Valid, Up and Egress Service Label	Yes	Generic IP/GRE OAM (PLP)	Yes	SDP Encapsulation with Egress Service Label (SLP)

**remote-sdp** — Specifies **svc-ping** reply message from the **far-end** should be sent using the same service tunnel encapsulation labeling as service traffic.

If **remote-sdp** is specified, the **far-end** responder attempts to use an egress *sdp-id* bound to the service with the message originator as the destination IP address with the VC-Label for the service. The *sdp-id* defines the encapsulation of the SDP tunnel encapsulation used to reply to the originator; this can be IP/GRE or MPLS. On responder egress, the service-ID must have an associated VC-Label to reach the originator address of the *sdp-id* and the *sdp-id* must be operational for the message to be sent.

If **remote-sdp** is not specified, the **svc-ping** request message is sent with GRE encapsulation with the OAM label.

The following table indicates how the message response is encapsulated based on the state of the remote service ID.

Remote Service State	Message Encapsulation	
	remote-sdp Not Specified	remote-sdp Specified
Invalid Ingress Service Label	Generic IP/GRE OAM (PLP)	Generic IP/GRE OAM (PLP)
Invalid Service-ID	Generic IP/GRE OAM (PLP)	Generic IP/GRE OAM (PLP)
No Valid SDP-ID Bound on Service-ID	Generic IP/GRE OAM (PLP)	Generic IP/GRE OAM (PLP)
SDP-ID Valid But Down	Generic IP/GRE OAM (PLP)	Generic IP/GRE OAM (PLP)
SDP-ID Valid and Up, but No Service Label	Generic IP/GRE OAM (PLP)	Generic IP/GRE OAM (PLP)
SDP-ID Valid and Up, Egress Service Label, but VC-ID Mismatch	Generic IP/GRE OAM (PLP)	Generic IP/GRE OAM (PLP)
SDP-ID Valid and Up, Egress Service Label, but VC-ID Match	Generic IP/GRE OAM (PLP)	SDP Encapsulation with Egress Service Label (SLP)

### Sample Output

```
*A:router1> svc-ping far-end 10.10.10.10 service 101 local-sdp remote-sdp
Request Result: Sent - Reply Received
```

```
Service-ID: 101
```

```
Err      Basic Info          Local      Remote
---      -----
___      Type:                   TLS        TLS
___      Admin State:           Up         Up
___      Oper State:            Up         Up
___      Service-MTU:           1514      1514
___      Customer ID:           1001      1001
```

```
Err      System IP Interface Info
---      -----
```

```
Local Interface Name: "7750 SR-System-IP-Interface (Up to 32 chars)..."
```

```
___      Local IP Interface State:      Up
___      Local IP Address:              10.10.10.11
___      IP Address Expected By Remote: 10.10.10.11
___      Expected Remote IP Address:    10.10.10.10
___      Actual Remote IP Address:      10.10.10.10
```

```
Err      SDP-ID Info          Local      Remote
---      -----
___      Path Used:             Yes        Yes
___      SDP-ID:                123       325
___      Administrative State:   Up         Up
___      Operative State:       Up         Up
___      Binding Admin State:   Up         Up
___      Binding Oper State:    Up         Up
___      Binding VC-ID:         101       101
```

```
Err      Service Label Information  Label      Source      State
---      -----
```

—	Local Egress Label:	45	Signaled	Up
—	Remote Expected Ingress:	45	Signaled	Up
—	Remote Egress:	34	Signaled	Up
—	Local Expected Ingress:	34	Signaled	Up

## host-connectivity-verify

<b>Syntax</b>	<b>host-connectivity-verify service</b> <i>service-id</i> [ <b>sap</b> <i>sap-id</i> ] <b>host-connectivity-verify subscriber</b> <i>sub-ident-string</i> [ <b>sla-profile</b> <i>sla-profile-name</i> ]
<b>Context</b>	oam
<b>Description</b>	This command enables host connectivity verification checks.
<b>Parameters</b>	<b>service</b> <i>service-id</i> — Specifies the service ID to diagnose or manage. <b>Values</b> 1 — 2147483647 <b>sap</b> <i>sap-id</i> — Specifies the physical port identifier portion of the SAP definition. See <Link>Common CLI Command Descriptions on page 327 for command syntax. <b>sub-profile</b> <i>sub-profile-name</i> — Specifies an existing subscriber profile name. The subscriber profile is configured in the <b>config&gt;subscr-mgmt&gt;sub-profile</b> context. <b>sla-profile</b> <i>sla-profile-name</i> — Specifies an existing SLA profile name. The SLA profile is configured in the <b>config&gt;subscr-mgmt&gt;sla-profile</b> context.

## vprn-ping

<b>Syntax</b>	<b>vprn-ping</b> <i>service-id</i> <b>source</b> <i>ip-address</i> <b>destination</b> <i>ip-address</i> [ <b>fc</b> <i>fc-name</i> [ <b>profile</b> [ <b>in</b>   <b>out</b> ]]][ <b>size</b> <i>size</i> ] [ <b>ttl</b> <i>vc-label-ttl</i> ] [ <b>return-control</b> ] [ <b>interval</b> <i>interval</i> ] [ <b>count</b> <i>send-count</i> ] [ <b>timeout</b> <i>timeout</i> ]
<b>Context</b>	<GLOBAL> config>saa>test>type
<b>Description</b>	This command performs a VPRN ping.
<b>Parameters</b>	<b>service</b> <i>service-id</i> — The VPRN service ID to diagnose or manage. <b>Values</b> <i>service-id</i> : 1 — 2147483647 <i>svc-name</i> : 64 characters maximum <b>source</b> <i>ip-address</i> — The IP prefix for the source IP address in dotted decimal notation. <b>Values</b> <i>ipv4-address</i> : 0.0.0.0 — 255.255.255.255 <i>ipv6-address</i> : x:x:x:x:x:x:x x:x:x:x:x:d.d.d.d x: [0..FFFF]H d: [0..255]D

**destination** *ip-address* — The IP prefix for the destination IP address in dotted decimal notation.

**Values** 0.0.0.0 — 255.255.255.255

**size** *octets* — The OAM request packet size in octets, expressed as a decimal integer.

**Values** 1 — 9198

**ttl** *vc-label-ttl* — The TTL value in the VC label for the OAM request, expressed as a decimal integer.

**Default** 255

**Values** 1 — 255

**return-control** — Specifies the response to come on the control plane.

**interval** *interval* — The **interval** parameter in seconds, expressed as a decimal integer. This parameter is used to override the default request message send interval and defines the minimum amount of time that must expire before the next message request is sent.

If the **interval** is set to 1 second where the **timeout** value is set to 10 seconds, then the maximum time between message requests is 10 seconds and the minimum is 1 second. This depends upon the receipt of a message reply corresponding to the outstanding message request.

**Default** 1

**Values** 1 — 10

**count** *send-count* — The number of messages to send, expressed as a decimal integer. The **count** parameter is used to override the default number of message requests sent. Each message request must either timeout or receive a reply before the next message request is sent. The message **interval** value must be expired before the next message request is sent.

**Default** 1

**Values** 1 — 100

**timeout** *timeout* — The **timeout** parameter in seconds, expressed as a decimal integer. This value is used to override the default **timeout** value and is the amount of time that the router will wait for a message reply after sending the message request. Upon the expiration of message timeout, the requesting router assumes that the message response will not be received. Any response received after the request times out will be silently discarded.

**Default** 5

**Values** 1 — 100

**fc-name** — The forwarding class of the MPLS echo request encapsulation.

**Default** be

**Values** be, l2, af, l1, h2, ef, h1, nc

**profile** {in | out} — The profile state of the MPLS echo request encapsulation.

**Default** out

**Sample Output**

```

A:PE_1# oam vprn-ping 25 source 10.4.128.1 destination 10.16.128.0
Sequence Node-id Reply-Path Size RTT
-----
[Send request Seq. 1.]
1 10.128.0.3:cpm In-Band 100 0ms
-----
...
A:PE_1#
-----
A:PE_1#

```

**vprn-trace**

- Syntax** **vprn-trace** *service-id* **source** *src-ip* **destination** *ip-address* [**fc** *fc-name* [**profile** [**in** | **out**]]] [**size** *size*] [**min-ttl** *vc-label-ttl*] [**max-ttl** *vc-label-ttl*] [**return-control**] [**probe-count** *probes-per-hop*] [**interval** *seconds*] [**timeout** *timeout*]
- Context** <GLOBAL>  
config>saa>test>type
- Description** Performs VPRN trace.
- Parameters**
- service** *service-id* — The VPRN service ID to diagnose or manage.
- Values**
- |                     |                       |
|---------------------|-----------------------|
| <i>service-id</i> : | 1 — 2147483647        |
| <i>svc-name</i> :   | 64 characters maximum |
- source** *src-ip* — The IP prefix for the source IP address in dotted decimal notation.
- Values**
- |               |                           |
|---------------|---------------------------|
| ipv4-address: | 0.0.0.0 — 255.255.255.255 |
| ipv6-address: | x:x:x:x:x:x:x             |
|               | x:x:x:x:x:d.d.d           |
|               | x: [0..FFFF]H             |
|               | d: [0..255]D              |
- destination** *dst-ip* — The IP prefix for the destination IP address in dotted decimal notation.
- Values** 0.0.0.0 — 255.255.255.255
- size** *octets* — The OAM request packet size in octets, expressed as a decimal integer.
- min-ttl** *vc-label-ttl* — The minimum TTL value in the VC label for the trace test, expressed as a decimal integer.
- Default** 1
- Values** 1 — 255
- max-ttl** *vc-label-ttl* — The maximum TTL value in the VC label for the trace test, expressed as a decimal integer.
- Default** 4
- Values** 1 — 255

**return-control** — Specifies the OAM reply to a data plane OAM request be sent using the control plane instead of the data plane.

**Default** OAM reply sent using the data plane.

**probe-count** *send-count* — The number of OAM requests sent for a particular TTL value, expressed as a decimal integer.

**Default** 1

**Values** 1 — 10

**interval** *seconds* — The **interval** parameter in seconds, expressed as a decimal integer. This parameter is used to override the default request message send interval and defines the minimum amount of time that must expire before the next message request is sent.

If the **interval** is set to 1 second where the **timeout** value is set to 10 seconds, then the maximum time between message requests is 10 seconds and the minimum is 1 second. This depends upon the receipt of a message reply corresponding to the outstanding message request.

**Default** 1

**Values** 1 — 10

**timeout** *timeout* — The **timeout** parameter in seconds, expressed as a decimal integer. This value is used to override the default **timeout** value and is the amount of time that the router will wait for a message reply after sending the message request. Upon the expiration of message timeout, the requesting router assumes that the message response will not be received. Any response received after the request times out will be silently discarded.

**Default** 3

**Values** 1 — 10

**fc-name** — The forwarding class of the MPLS echo request encapsulation.

**Default** be

**Values** be, l2, af, l1, h2, ef, h1, nc

**profile** {in | out} — The profile state of the MPLS echo request encapsulation.

**Default** out

### Sample Output

```
A:PE_1# oam vprn-trace 25 source 10.4.128.1 destination 10.16.128.0
TTL Seq Reply Node-id          Rcvd-on          Reply-Path RTT
-----
[Send request TTL: 1, Seq. 1.]
1  1  1  10.128.0.4          cpm              In-Band         0ms
Requestor 10.128.0.1 Route: 0.0.0.0/0
  Vpn Label: 131071 Metrics 0 Pref 170 Owner bgpVpn
  Next Hops: [1] ldp tunnel
  Route Targets: [1]: target:65100:1
Responder 10.128.0.4 Route: 10.16.128.0/24
  Vpn Label: 131071 Metrics 0 Pref 170 Owner bgpVpn
  Next Hops: [1] ldp tunnel
  Route Targets: [1]: target:65001:100
```

```
[Send request TTL: 2, Seq. 1.]
2 1 1 10.128.0.3 cpm In-Band 0ms
  Requestor 10.128.0.1 Route: 0.0.0.0/0
    Vpn Label: 131071 Metrics 0 Pref 170 Owner bgpVpn
    Next Hops: [1] ldp tunnel
    Route Targets: [1]: target:65100:1
  Responder 10.128.0.3 Route: 10.16.128.0/24
    Vpn Label: 0 Metrics 0 Pref 0 Owner local
    Next Hops: [1] ifIdx 2 nextHopIp 10.16.128.0
```

```
[Send request TTL: 3, Seq. 1.]
```

```
[Send request TTL: 4, Seq. 1.]
```

```
...
```

```
-----
A:PE_1#
```

## VPLS MAC Diagnostics

### cpe-ping

<b>Syntax</b>	<b>cpe-ping service</b> <i>service-id</i> <b>destination</b> <i>ip-address</i> <b>source</b> <i>ip-address</i> [ <b>ttl</b> <i>vc-label-ttl</i> ] [ <b>return-control</b> ] [ <b>source-mac</b> <i>ieee-address</i> ] [ <b>fc</b> <i>fc-name</i> [ <b>profile</b> { <b>in</b>   <b>out</b> }] [ <b>interval</b> <i>interval</i> ] [ <b>count</b> <i>send-count</i> ] [ <b>send-control</b> ]
<b>Context</b>	oam config>saa>test>type
<b>Description</b>	This ping utility determines the IP connectivity to a CPE within a specified VPLS service.
<b>Parameters</b>	<p><b>service</b> <i>service-id</i> — The service ID of the service to diagnose or manage.</p> <p><b>Values</b> 1 — 2147483647</p> <p><b>Values</b> <i>service-id:</i> 1 — 2147483647 <i>svc-name:</i> 64 characters maximum</p> <p><b>destination</b> <i>ip-address</i> — Specifies the IP address to be used as the destination for performing an OAM ping operations.</p> <p><b>source</b> <i>ip-address</i> — Specify an unused IP address in the same network that is associated with the VPLS.</p> <p><b>ttl</b> <i>vc-label-ttl</i> — The TTL value in the VC label for the OAM MAC request, expressed as a decimal integer.</p> <p><b>Default</b> 255</p> <p><b>Values</b> 1 — 255</p> <p><b>return-control</b> — Specifies the MAC OAM reply to a data plane MAC OAM request be sent using the control plane instead of the data plane.</p> <p><b>Default</b> MAC OAM reply sent using the data plane.</p> <p><b>source-mac</b> <i>ieee-address</i> — Specify the source MAC address that will be sent to the CPE. If not specified or set to 0, the MAC address configured for the CPM is used.</p> <p><b>fc-name</b> — The forwarding class of the MPLS echo request encapsulation.</p> <p><b>Default</b> be</p> <p><b>Values</b> be, l2, af, l1, h2, ef, h1, nc</p> <p><b>profile</b> {<b>in</b>   <b>out</b>} — The profile state of the MPLS echo request encapsulation.</p> <p><b>Default</b> out</p> <p><b>interval</b> <i>interval</i> — The <b>interval</b> parameter in seconds, expressed as a decimal integer. This parameter is used to override the default request message send interval and defines the minimum amount of time that must expire before the next message request is sent.</p> <p>If the <b>interval</b> is set to 1 second where the <b>timeout</b> value is set to 10 seconds, then the maximum</p>

time between message requests is 10 seconds and the minimum is 1 second. This depends upon the receipt of a message reply corresponding to the outstanding message request.

**Default** 1

**Values** 1 — 10

**count** *send-count* — The number of messages to send, expressed as a decimal integer. The **count** parameter is used to override the default number of message requests sent. Each message request must either timeout or receive a reply before the next message request is sent. The message **interval** value must be expired before the next message request is sent.

**Default** 1

**Values** 1 — 255

**send-control** — Specifies the MAC OAM request be sent using the control plane instead of the data plane.

**Default** MAC OAM request sent using the data plane.

## mac-populate

**Syntax** **mac-populate** *service-id* **mac** *ieee-address* [**flood**] [**age** *seconds*] [**force**]

**Context** oam

**Description** This command populates the FIB with an OAM-type MAC entry indicating the node is the egress node for the MAC address and optionally floods the OAM MAC association throughout the service. The **mac-populate** command installs an OAM MAC into the service FIB indicating the device is the egress node for a particular MAC address. The MAC address can be bound to a particular SAP (the **target-sap**) or can be associated with the control plane in that any data destined to the MAC address is forwarded to the control plane (cpm). As a result, if the service on the node has neither a FIB nor an egress SAP, then it is not allowed to initiate a **mac-populate**.

The MAC address that is populated in the FIBs in the provider network is given a type OAM, so that it can be treated distinctly from regular dynamically learned or statically configured MACs. Note that OAM MAC addresses are operational MAC addresses and are not saved in the device configuration. An exec file can be used to define OAM MACs after system initialization.

The **force** option in **mac-populate** forces the MAC in the table to be type OAM in the case it already exists as a dynamic, static or an OAM induced learned MAC with some other type binding. An OAM-type MAC cannot be overwritten by dynamic learning and allows customer packets with the MAC to either ingress or egress the network while still using the OAM MAC entry.

The **flood** option causes each upstream node to learn the MAC (that is, populate the local FIB with an OAM MAC entry) and to flood the request along the data plane using the flooding domain. The flooded **mac-populate** request can be sent via the data plane or the control plane. The **send-control** option specifies the request be sent using the control plane. If **send-control** is not specified, the request is sent using the data plane.

An **age** can be provided to age a particular OAM MAC using a specific interval. By default, OAM MAC addresses are not aged and can be removed with a **mac-purge** or with an FDB clear operation.

When split horizon group (SHG) is configured, the flooding domain depends on which SHG the packet originates from. The **target-sap** *sap-id* value dictates the originating SHG information.

**Parameters** **service** *service-id* — The Service ID of the service to diagnose or manage.

**Values** 1 — 2147483647

**destination** *ieee-address* — The MAC address to be populated.

**flood** — Sends the OAM MAC populate to all upstream nodes.

**Default** MAC populate only the local FIB.

**age** *seconds* — The age for the OAM MAC, expressed as a decimal integer.

**Default** The OAM MAC does not age.

**Values** 1 — 65535

**force** — Converts the MAC to an OAM MAC even if it currently another type of MAC.

**Default** Do not overwrite type.

**target-sap** *sap-id* — The local target SAP bound to a service on which to associate the OAM MAC. By default, the OAM MAC is associated with the control plane, that is, it is associated with the CPU on the router.

When the **target-sap** *sap-id* value is not specified the MAC is bound to the CPM. The originating SHG is 0 (zero). When the **target-sap** *sap-id* value is specified, the originating SHG is the SHG of the target-sap.

**Default** Associate OAM MAC with the control plane (CPU).

## mac-purge

**Syntax** **mac-purge** *service-id* **target** *ieee-address* [**flood**] [**send-control**] [**register**]

**Context** oam

**Description** This command removes an OAM-type MAC entry from the FIB and optionally floods the OAM MAC removal throughout the service. A **mac-purge** can be sent via the forwarding path or via the control plane. When sending the MAC purge using the data plane, the TTL in the VC label is set to 1. When sending the MAC purge using the control plane, the packet is sent directly to the system IP address of the next hop.

A MAC address is purged only if it is marked as OAM. A mac-purge request is an HVPLS OAM packet, with the following fields. The Reply Flags is set to 0 (since no reply is expected), the Reply Mode and Reserved fields are set to 0. The Ethernet header has source set to the (system) MAC address, the destination set to the broadcast MAC address. There is a VPN TLV in the FEC Stack TLV to identify the service domain.

If the register option is provided, the R bit in the Address Delete flags is turned on.

The **flood** option causes each upstream node to be sent the OAM MAC delete request and to flood the request along the data plane using the flooding domain. The flooded **mac-purge** request can be sent via the data plane or the control plane. The **send-control** option specifies the request be sent using the control plane. If **send-control** is not specified, the request is sent using the data plane.

The **register** option reserves the MAC for OAM testing where it is no longer an active MAC in the FIB for forwarding, but it is retained in the FIB as a registered OAM MAC. Registering an OAM MAC prevents relearns for the MAC based on customer packets. Relearning a registered MAC can only be done through a **mac-populate** request. The originating SHG is always 0 (zero).

- Parameters**
- service** *service-id* — The service ID of the service to diagnose or manage.
    - Values** 1 — 2147483647
  - target** *ieee-address* — The MAC address to be purged.
  - flood** — Sends the OAM MAC purge to all upstream nodes.
    - Default** MAC purge only the local FIB.
  - send-control** — Send the mac-purge request using the control plane.
    - Default** Request is sent using the data plane.
  - register** — Reserve the MAC for OAM testing.
    - Default** Do not register OAM MAC.

## mac-ping

- Syntax** **mac-ping service** *service-id* **destination** *dst-ieee-address* [**source** *src-ieee-address*] [**fc** *fc-name* [**profile** *in* | *out*]] [**size** *octets*] [**ttl** *vc-label-ttl*] [**count** *send-count*] [**send-control**] [**return-control**] [**interval** *interval*] [**timeout** *timeout*]
- Context** oam  
config>saa>test>type
- Description** The **mac-ping** utility is used to determine the existence of an egress SAP binding of a given MAC within a VPLS service.
- A **mac-ping** packet can be sent via the control plane or the data plane. The **send-control** option specifies the request be sent using the control plane. If **send-control** is not specified, the request is sent using the data plane.
- A **mac-ping** is forwarded along the flooding domain if no MAC address bindings exist. If MAC address bindings exist, then the packet is forwarded along those paths, provided they are active. A response is generated only when there is an egress SAP binding for that MAC address or if the MAC address is a “local” OAM MAC address associated with the device’s control plan.
- A **mac-ping** reply can be sent using the data plane or the control plane. The **return-control** option specifies the reply be sent using the control plane. If **return-control** is not specified, the request is sent using the data plane.
- A **mac-ping** with data plane reply can only be initiated on nodes that can have an egress MAC address binding. A node without a FIB and without any SAPs cannot have an egress MAC address binding, so it is not a node where replies in the data plane will be trapped and sent up to the control plane.
- A control plane request is responded to via a control plane reply only.

By default, MAC OAM requests are sent with the system or chassis MAC address as the source MAC. The **source** option allows overriding of the default source MAC for the request with a specific MAC address.

When a **source** *ieee-address* value is specified and the source MAC address is locally registered within a split horizon group (SHG), then this SHG membership will be used as if the packet originated from this SHG. In all other cases, SHG 0 (zero) will be used. Note that if the **mac-trace** is originated from a non-zero SHG, such packets will not go out to the same SHG.

If EMG is enabled, mac-ping will return only the first SAP in each chain.

**Parameters**

**service** *service-id* — The service ID of the service to diagnose or manage.

**Values** 1 — 2147483647

**destination** *ieee-address* — The destination MAC address for the OAM MAC request.

**size** *octets* — The MAC OAM request packet size in octets, expressed as a decimal integer. The request payload is padded to the specified size with a 6 byte PAD header and a byte payload of 0xAA as necessary. If the octet size specified is less than the minimum packet, the minimum sized packet necessary to send the request is used.

**Default** No OAM packet padding.

**Values** 1 — 65535

**ttl** *vc-label-ttl* — The TTL value in the VC label for the OAM MAC request, expressed as a decimal integer.

**Default** 255

**Values** 1 — 255

**send-control** — Specifies the MAC OAM request be sent using the control plane instead of the data plane.

**Default** MAC OAM request sent using the data plane.

**return-control** — Specifies the MAC OAM reply to a data plane MAC OAM request be sent using the control plane instead of the data plane.

**Default** MAC OAM reply sent using the data plane.

**source** *src-ieee-address* — The source MAC address from which the OAM MAC request originates. By default, the system MAC address for the chassis is used.

**Default** The system MAC address.

**Values** Any unicast MAC value.

**fc** *fc-name* — The **fc** parameter is used to test the forwarding class of the MPLS echo request packets. The actual forwarding class encoding is controlled by the network egress LSP-EXP mappings.

**Values** be, l2, af, l1, h2, ef, h1, nc

**profile** {**in** | **out**} — The profile state of the MPLS echo request encapsulation.

**Default** out

**interval** *interval* — The **interval** parameter in seconds, expressed as a decimal integer. This parame-

ter is used to override the default request message send interval and defines the minimum amount of time that must expire before the next message request is sent.

If the **interval** is set to 1 second where the **timeout** value is set to 10 seconds, then the maximum time between message requests is 10 seconds and the minimum is 1 second. This depends upon the receipt of a message reply corresponding to the outstanding message request.

**Default** 1

**Values** 1 — 10

**count** *send-count* — The number of messages to send, expressed as a decimal integer. The **count** parameter is used to override the default number of message requests sent. Each message request must either timeout or receive a reply before the next message request is sent. The message **interval** value must be expired before the next message request is sent.

**Default** 1

**Values** 1 — 100

**timeout** *timeout* — The **timeout** parameter in seconds, expressed as a decimal integer. This value is used to override the default **timeout** value and is the amount of time that the router will wait for a message reply after sending the message request. Upon the expiration of message timeout, the requesting router assumes that the message response will not be received. Any response received after the request times out will be silently discarded.

**Default** 5

**Values** 1 — 10

## mac-trace

**Syntax** **mac-trace service** *service-id* **destination** *ieee-address* [**size** *octets*] [**min-ttl** *vc-label-ttl*] [**max-ttl** *vc-label-ttl*] [**send-control**] [**return-control**] [**source** *ieee-address*] [**z-count** *probes-per-hop*] [**interval** *interval*] [**timeout** *timeout*]

**Context** oam  
config>saa>test>type

**Description** This command displays the hop-by-hop path for a destination MAC address within a VPLS. The MAC traceroute operation is modeled after the IP traceroute utility which uses ICMP echo request and reply packets with increasing TTL values to determine the hop-by-hop route to a destination IP. The MAC traceroute command uses Alcatel-Lucent OAM packets with increasing TTL values to determine the hop-by-hop route to a destination MAC.

In a MAC traceroute, the originating device creates a MAC ping echo request packet for the MAC to be tested with increasing values of the TTL. The echo request packet is sent through the control plane or data plane and awaits a TTL exceeded response or the echo reply packet from the device with the destination MAC. The devices that reply to the echo request packets with the TTL exceeded and the echo reply are displayed.

When a **source** *ieee-address* value is specified and the source MAC address is locally registered within a split horizon group (SHG), then this SHG membership will be used as if the packet origi-

nated from this SHG. In all other cases, SHG 0 (zero) will be used. Note that if the **mac-ping** is originated from a non-zero SHG, such packets will not go out to the same SHG.

If EMG is enabled, mac-trace will return only the first SAP in each chain.

**Parameters** **service** *service-id* — The Service ID of the service to diagnose or manage.

**Values** 1 — 2147483647

**destination** *ieee-address* — The destination MAC address to be traced.

**size** *octets* — The MAC OAM request packet size in octets, expressed as a decimal integer. The request payload is padded to the specified size with a 6 byte PAD header and a byte payload of 0xAA as necessary. If the octet size specified is less than the minimum packet, the minimum sized packet necessary to send the request is used.

**Default** No OAM packet padding.

**Values** 1 — 65535

**min-ttl** *vc-label-ttl* — The minimum TTL value in the VC label for the MAC trace test, expressed as a decimal integer.

**Default** 1

**Values** 1 — 255

**max-ttl** *vc-label-ttl* — The maximum TTL value in the VC label for the MAC trace test, expressed as a decimal integer.

**Default** 4

**Values** 1 — 255

**send-control** — Specifies the MAC OAM request be sent using the control plane instead of the data plane.

**Default** MAC OAM request sent using the data plane.

**return-control** — Specifies the MAC OAM reply to a data plane MAC OAM request be sent using the control plane instead of the data plane.

**Default** MAC OAM reply sent using the data plane.

**source** *ieee-address* — The source MAC address from which the OAM MAC request originates. By default, the system MAC address for the chassis is used.

**Default** The system MAC address.

**Values** Any unicast MAC value.

**send-count** *send-count* — The number of MAC OAM requests sent for a particular TTL value, expressed as a decimal integer.

**Default** 1

**Values** 1 — 100

**interval** *interval* — The **interval** parameter in seconds, expressed as a decimal integer. This parameter is used to override the default request message send interval and defines the minimum amount of time that must expire before the next message request is sent.

If the **interval** is set to 1 second, and the **timeout** value is set to 10 seconds, then the maximum time between message requests is 10 seconds and the minimum is 1 second. This depends upon the receipt of a message reply corresponding to the outstanding message request.

**Default** 1

**Values** 1 — 10

**timeout** *timeout* — The **timeout** parameter in seconds, expressed as a decimal integer. This value is used to override the default **timeout** value and is the amount of time that the router will wait for a message reply after sending the message request. Upon the expiration of message timeout, the requesting router assumes that the message response will not be received. Any response received after the request times out will be silently discarded.

**Default** 5

**Values** 1 — 10

---

## IGMP Snooping Diagnostics

### mfib-ping

<b>Syntax</b>	<b>mfib-ping service</b> <i>service-id</i> <b>source</b> <i>src-ip</i> <b>destination</b> <i>mcast-address</i> [ <b>size</b> <i>size</i> ] [ <b>ttl</b> <i>vc-label-ttl</i> ] [ <b>return-control</b> ] [ <b>interval</b> <i>interval</i> ] [ <b>count</b> <i>send-count</i> ] [ <b>timeout</b> <i>timeout</i> ]
<b>Context</b>	oam
<b>Description</b>	<p>The mfib-ping utility determines the list of SAPs which egress a certain IP multicast stream (identified by source unicast and destination multicast IP addresses) within a VPLS service. An mfib-ping packet is always sent via the data plane.</p> <p>An mfib-ping is forwarded across the VPLS following the MFIB. If an entry for the specified source unicast and destination multicast IP addresses exist in the MFIB for that VPLS, then the packet is forwarded along those paths, provided they are active. A response is generated only when there is an egress SAP binding for the specified IP multicast stream.</p> <p>An mfib-ping reply can be sent using the data plane or the control plane. The return-control option specifies the reply be sent using the control plane. If return-control is not specified, the reply is sent using the data plane.</p>
<b>Parameters</b>	<p><b>service</b> <i>service-id</i> — The service ID of the VPLS to diagnose or manage.</p> <p><b>Values</b> 1 — 2147483647</p> <p><b>source</b> <i>src-ip</i> — The source IP address for the OAM request.</p> <p><b>destination</b> <i>mcast-address</i> — The destination multicast address for the OAM request.</p> <p><b>size</b> <i>size</i> — The multicast OAM request packet size in octets, expressed as a decimal integer. The request payload is padded to the specified size with a 6 byte PAD header and a byte payload of 0xAA as necessary.</p> <p>If the octet size specified is less than the minimum packet, the minimum sized packet necessary to send the request is used.</p> <p><b>Default</b> No OAM packet padding.</p> <p><b>Values</b> 1 — 65535</p> <p><b>ttl</b> <i>vc-label-ttl</i> — The TTL value in the VC label for the OAM request, expressed as a decimal integer.</p> <p><b>Default</b> 255</p> <p><b>Values</b> 1 — 255</p> <p><b>return-control</b> — Specifies the OAM reply has to be sent using the control plane instead of the data plane.</p> <p><b>Default</b> OAM reply is sent using the data plane.</p> <p><b>interval</b> <i>interval</i> — The interval parameter in seconds, expressed as a decimal integer. This parameter is used to override the default request message send interval and defines the minimum</p>

amount of time that must expire before the next message request is sent.

If the interval is set to 1 second where the timeout value is set to 10 seconds, then the maximum time between message requests is 10 seconds and the minimum is 1 second. This depends upon the receipt of a message reply corresponding to the outstanding message request.

**Default** 1

**Values** 1 — 10

**count** *send-count* — The number of messages to send, expressed as a decimal integer. The count parameter is used to override the default number of message requests sent. Each message request must either timeout or receive a reply before the next message request is sent.

The message interval value must be expired before the next message request is sent.

**Default** 1

**Values** 1 — 100

**timeout** *seconds* — The timeout parameter in seconds, expressed as a decimal integer. This value is used to override the default timeout value and is the amount of time that the 7750 SR will wait for a message reply after sending the next message request.

Upon the expiration of message timeout, the requesting 7750 SR assumes that the message response will not be received. A 'request timeout' message is displayed by the CLI for each message request sent that expires. Any response received after the request times out will be silently discarded.

**Default** 5

**Values** 1 — 100

**Special Cases**

**MFIB 224.0.0.X pings** — Mfib-ping requests directed to a destination address in the special 224.0.0.X range are flooded throughout the service flooding domain and will receive a response from all operational SAPs. Note that SAPs that are operationally down do not reply. If EMG is enabled, mfib-ping will return only the first SAP in each chain.

**Multicast FIB Connectivity Test Sample Output**

```
A:ALA-A# oam mfib-ping service 10 source 10.10.10.1 destination 225.0.0.1 count 2
Seq Node-id Path Size RTT
-----
[Send request Seq. 1.]
1 51.51.51.51:sap1/1/1 Self 100 0ms
1 54.54.54.54:sap1/1/2 In-Band 100 20ms
1 54.54.54.54:sap1/1/3 In-Band 100 10ms
1 52.52.52.52:sap1/1/3 In-Band 100 20ms
[Send request Seq. 2.]
2 51.51.51.51:sap1/1/1 Self 100 0ms
2 52.52.52.52:sap1/1/2 In-Band 100 10ms
2 54.54.54.54:sap1/1/2 In-Band 100 10ms
2 52.52.52.52:sap1/1/3 In-Band 100 20ms
2 54.54.54.54:sap1/1/3 In-Band 100 30ms
-----
A:ALA-AIM# oam mfib-ping service 1 source 11.11.0.0 destination 224.0.0.1
Seq Node-id Path Size RTT
-----
```

## OAM and SAA Command Reference

```
[Send request Seq. 1.]
1  10.20.1.3:sap1/1/5:1          Not in MFIB Self    40    0ms
1  10.20.1.3:sap1/1/2:1          Self               40    10ms
[Echo replies received: 2]
-----
A:ALA-AIM#
```

---

## EFM Commands

### efm

<b>Syntax</b>	<b>efm</b> <i>port-id</i>
<b>Context</b>	oam
<b>Description</b>	<p>This command enables Ethernet in the First Mile (EFM) OAM tests loopback tests on the specified port. The EFM OAM remote loopback OAMPDU will be sent to the peering device to trigger remote loopback.</p> <p>When EFM OAM is disabled or shutdown on a port, the dying gasp flag for the OAMPDU is set for the OAMPDUs sent to the peer. This speeds up the peer loss detection time.</p>
<b>Parameters</b>	<i>port-id</i> — Specify the port ID in the slot/mda/port format.

### local-loopback

<b>Syntax</b>	<b>local-loopback</b> { <b>start</b>   <b>stop</b> }
<b>Context</b>	oam>emf
<b>Description</b>	This command enables local loopback tests on the specified port.

### remote-loopback

<b>Syntax</b>	<b>remote-loopback</b> { <b>start</b>   <b>stop</b> }
<b>Context</b>	oam>emf
<b>Description</b>	<p>This command enables remote Ethernet in the First Mile (EFM) OAM loopback tests on the specified port. The EFM OAM remote loopback OAMPDU will be sent to the peering device to trigger remote loopback.</p> <p>In order for EFM OAM tunneling to function properly, EFM OAM tunneling should be configured for VLL services or a VPLS service with two SAPs only.</p>

---

## ETH-CFM OAM Commands

### linktrace

<b>Syntax</b>	<b>eth-cfm linktrace</b> <i>mac-address</i> <b>mep</b> <i>mep-id</i> <b>domain</b> <i>md-index</i> <b>association</b> <i>ma-index</i> [ <b>ttl</b> <i>tll-value</i> ]
<b>Context</b>	oam>eth-cfm
<b>Default</b>	The command specifies to initiate a linktrace test.
<b>Parameters</b>	<p><i>mac-address</i> — Specifies a unicast destination MAC address.</p> <p><b>mep</b> <i>mep-id</i> — Specifies the target MAC address.</p> <p><b>Values</b> 1 — 8191</p> <p><b>domain</b> <i>md-index</i> — Specifies the MD index.</p> <p><b>Values</b> 1 — 4294967295</p> <p><b>association</b> <i>ma-index</i> — Specifies the MA index.</p> <p><b>Values</b> 1 — 4294967295</p> <p><b>tll</b> <i>tll-value</i> — Specifies the TTL for a returned linktrace.</p> <p><b>Values</b> 0 — 255</p>

### loopback

<b>Syntax</b>	<b>eth-cfm loopback</b> <i>mac-address</i> <b>mep</b> <i>mep-id</i> <b>domain</b> <i>md-index</i> <b>association</b> <i>ma-index</i> [ <b>send-count</b> <i>send-count</i> ] [ <b>size</b> <i>data-size</i> ] [ <b>priority</b> <i>priority</i> ]
<b>Context</b>	oam>eth-cfm
<b>Default</b>	The command specifies to initiate a loopback test.
<b>Parameters</b>	<p><i>mac-address</i> — Specifies a unicast MAC address.</p> <p><b>mep</b> <i>mep-id</i> — Specifies target MAC address.</p> <p><b>Values</b> 1 — 8191</p> <p><b>domain</b> <i>md-index</i> — Specifies the MD index.</p> <p><b>Values</b> 1 — 4294967295</p> <p><b>association</b> <i>ma-index</i> — Specifies the MA index.</p> <p><b>Values</b> 1 — 4294967295</p> <p><b>send-count</b> <i>send-count</i> — Specifies the number of messages to send, expressed as a decimal integer. Loopback messages are sent back to back, with no delay between the transmissions.</p>

**Default** 1

**Values** 1 — 5

**size** *data-size* — The packet size in bytes, expressed as a decimal integer.

**Values** 0 — 1500

**priority** *priority* — Specifies a 3-bit value to be used in the VLAN tag, if present, in the transmitted frame.

**Values** 0 — 7

## eth-test

**Syntax** **eth-cfm eth-test** *mac-address* **mep** *mep-id* **domain** *md-index* **association** *ma-index* [**priority** *priority*] [**data-length** *data-length*]

**Context** oam eth-cfm

**Description** This command issues an ETH-CFM test.

**Parameters** *mac-address* — Specifies a unicast MAC address.

**mep** *mep-id* — Specifies target MAC address.

**Values** 1 — 8191

**domain** *md-index* — Specifies the MD index.

**Values** 1 — 4294967295

**association** *ma-index* — Specifies the MA index.

**Values** 1 — 4294967295

**data-length** *data-length* — Indicates the UDP data length of the echo reply, the length starting after the IP header of the echo reply.

**Values** 64 — 1500

**Default** 64

## one-way-delay-test

**Syntax** **eth-cfm one-way-delay-test** *mac-address* **mep** *mep-id* **domain** *md-index* **association** *ma-index* [**priority** *priority*]

**Context** oam eth-cfm

**Description** This command issues an ETH-CFM one-way delay test.

**Parameters** *mac-address* — Specifies a unicast MAC address.

**mep** *mep-id* — Specifies target MAC address.

**Values** 1 — 8191

**domain** *md-index* — Specifies the MD index.

**Values** 1 — 4294967295

**association** *ma-index* — Specifies the MA index.

**Values** 1 — 4294967295

**priority** *priority* — Specifies the priority.

**Values** 0 — 7

**Default** The CCM and LTM priority of the MEP.

## two-way-delay-test

**Syntax** **eth-cfm two-way-delay-test** *mac-address* **mep** *mep-id* **domain** *md-index* **association** *ma-index* [**priority** *priority*]

**Context** oam eth-cfm

**Description** This command issues an ETH-CFM two-way delay test.

**Parameters** *mac-address* — Specifies a unicast MAC address.

**mep** *mep-id* — Specifies target MAC address.

**Values** 1 — 8191

**domain** *md-index* — Specifies the MD index.

**Values** 1 — 4294967295

**association** *ma-index* — Specifies the MA index.

**Values** 1 — 4294967295

**priority** *priority* — Specifies the priority.

**Values** 0 — 7

**Default** The CCM and LTM priority of the MEP.

---

## Service Assurance Agent (SAA) Commands

### saa

<b>Syntax</b>	<b>saa</b>
<b>Context</b>	config
<b>Description</b>	This command creates the context to configure the Service Assurance Agent (SAA) tests.

### test

<b>Syntax</b>	<b>test name [owner test-owner]</b> <b>no test name</b>
<b>Context</b>	config>saa
<b>Description</b>	This command identifies a test and create/modify the context to provide the test parameters for the named test. Subsequent to the creation of the test instance the test can be started in the OAM context.  A test can only be modified while it is shut down.  The <b>no</b> form of this command removes the test from the configuration. In order to remove a test it can not be active at the time.
<b>Parameters</b>	<i>name</i> — Identify the saa test name to be created or edited.  <b>owner test-owner</b> — Specifies the owner of an SAA operation up to 32 characters in length.
<b>Values</b>	If a <i>test-owner</i> value is not specified, tests created by the CLI have a default owner “TiMOS CLI”.

### accounting-policy

<b>Syntax</b>	<b>accounting-policy acct-policy-id</b> <b>no accounting-policy</b>
<b>Context</b>	config>saa>test
<b>Description</b>	This command associates an accounting policy to the SAA test. The accounting policy must already be defined before it can be associated else an error message is generated.  A notification (trap) when a test is completed is issued whenever a test terminates.  The <b>no</b> form of this command removes the accounting policy association.
<b>Default</b>	none

**Parameters** *acct-policy-id* — Enter the accounting *policy-id* as configured in the **config>log>accounting-policy** context.

**Values** 1 — 99

## description

**Syntax** **description** *description-string*  
**no description**

**Context** config>saa>test

**Description** This command creates a text description stored in the configuration file for a configuration context. The **description** command associates a text string with a configuration context to help identify the content in the configuration file. The **no** form of this command removes the string from the configuration.

**Default** No description associated with the configuration context.

**Parameters** *string* — The description character string. Allowed values are any string up to 80 characters long composed of printable, 7-bit ASCII characters. If the string contains special characters (#, \$, spaces, etc.), the entire string must be enclosed within double quotes.

## continuous

**Syntax** **[no] continuous**

**Context** config>saa>test

**Description** This command specifies whether the SAA test is continuous. Once you have configured a test as continuous, you cannot start or stop it by using the **saa** command. The **no** form of the command disables the continuous running of the test. Use the **shutdown** command to disable the test.

## jitter-event

**Syntax** **jitter-event rising-threshold** *threshold* [**falling-threshold** *threshold*] [**direction**]  
**no jitter-event**

**Context** config>saa>test

**Description** Specifies that at the termination of an SAA test probe, the calculated jitter value is evaluated against the configured rising and falling jitter thresholds. SAA threshold events are generated as required. Once the threshold (rising/falling) is crossed, it is disabled from generating additional events until the opposite threshold is crossed. If a falling-threshold is not supplied, the rising threshold will be re-enabled when it falls below the threshold after the initial crossing that generate the event.

The configuration of jitter event thresholds is optional.

<b>Parameters</b>	<p><b>rising-threshold</b> <i>threshold</i> — Specifies a rising threshold jitter value. When the test run is completed, the calculated jitter value is compared to the configured jitter rising threshold. If the test run jitter value is greater than the configured rising threshold value then an SAA threshold event is generated. The SAA threshold event is <code>tmnxOamSaaThreshold</code>, logger application OAM, event #2101.</p> <p><b>Default</b> 0</p> <p><b>Values</b> 0 — 2147483 milliseconds</p> <p><b>falling-threshold</b> <i>threshold</i> — Specifies a falling threshold jitter value. When the test run is completed, the calculated jitter value is compared to the configured jitter falling threshold. If the test run jitter value is greater than the configured falling threshold value then an SAA threshold event is generated. The SAA threshold event is <code>tmnxOamSaaThreshold</code>, logger application OAM, event #2101.</p> <p><b>Default</b> 0</p> <p><b>Values</b> 0 — 2147483 milliseconds</p> <p><i>direction</i> — Specifies the direction for OAM ping responses received for an OAM ping test run.</p> <p><b>Values</b> <b>inbound</b> — Monitor the value of jitter calculated for the inbound, one-way, OAM ping responses received for an OAM ping test run.  <b>outbound</b> — Monitor the value of jitter calculated for the outbound, one-way, OAM ping requests sent for an OAM ping test run.  <b>roundtrip</b> — Monitor the value of jitter calculated for the round trip, two-way, OAM ping requests and replies for an OAM ping test run.</p> <p><b>Default</b> roundtrip</p>
-------------------	--

## latency-event

<b>Syntax</b>	<b>latency-event rising-threshold</b> <i>threshold</i> [ <b>falling-threshold</b> <i>threshold</i> ] [ <b>direction</b> ] <b>no latency-event</b>
<b>Context</b>	config>saa>test
<b>Description</b>	<p>Specifies that at the termination of an SAA test probe, the calculated latency event value is evaluated against the configured rising and falling latency event thresholds. SAA threshold events are generated as required.</p> <p>Once the threshold (rising/falling) is crossed, it is disabled from generating additional events until the opposite threshold is crossed. If a falling-threshold is not supplied, the rising threshold will be re-enabled when it falls below the threshold after the initial crossing that generate the event.</p> <p>The configuration of latency event thresholds is optional.</p>
<b>Parameters</b>	<p><b>rising-threshold</b> <i>threshold</i> — Specifies a rising threshold latency value. When the test run is completed, the calculated latency value is compared to the configured latency rising threshold. If the test run latency value is greater than the configured rising threshold value then an SAA threshold event is generated. The SAA threshold event is <code>tmnxOamSaaThreshold</code>, logger application</p>

OAM, event #2101.

**Default** 0

**Values** 0 — 2147483 milliseconds

**falling-threshold *threshold*** — Specifies a falling threshold latency value. When the test run is completed, the calculated latency value is compared to the configured latency falling threshold. If the test run latency value is greater than the configured falling threshold value then an SAA threshold event is generated. The SAA threshold event is `tmnxOamSaaThreshold`, logger application OAM, event #2101.

**Default** 0

**Values** 0 — 2147483 milliseconds

*direction* — Specifies the direction for OAM ping responses received for an OAM ping test run.

**Values** **inbound** — Monitor the value of jitter calculated for the inbound, one-way, OAM ping responses received for an OAM ping test run.

**outbound** — Monitor the value of jitter calculated for the outbound, one-way, OAM ping requests sent for an OAM ping test run.

**roundtrip** — Monitor the value of jitter calculated for the round trip, two-way, OAM ping requests and replies for an OAM ping test run.

**Default** roundtrip

## loss-event

**Syntax** `loss-event rising-threshold threshold [falling-threshold threshold] [direction]`  
`no loss-event`

**Context** `config>saa>test`

**Description** Specifies that at the termination of an SAA testrun, the calculated loss event value is evaluated against the configured rising and falling loss event thresholds. SAA threshold events are generated as required.

The configuration of loss event thresholds is optional.

**Parameters** **rising-threshold *threshold*** — Specifies a rising threshold loss event value. When the test run is completed, the calculated loss event value is compared to the configured loss event rising threshold. If the test run loss event value is greater than the configured rising threshold value then an SAA threshold event is generated. The SAA threshold event is `tmnxOamSaaThreshold`, logger application OAM, event #2101.

**Default** 0

**Values** 0 — 2147483647 packets

**falling-threshold *threshold*** — Specifies a falling threshold loss event value. When the test run is completed, the calculated loss event value is compared to the configured loss event falling threshold. If the test run loss event value is greater than the configured falling threshold value then an SAA threshold event is generated. The SAA threshold event is `tmnxOamSaaThreshold`, logger application OAM, event #2101.

**Default** 0

**Values** 0 — 2147483647 packets

*direction* — Specifies the direction for OAM ping responses received for an OAM ping test run.

**Values** **inbound** — Monitor the value of jitter calculated for the inbound, one-way, OAM ping responses received for an OAM ping test run.

**outbound** — Monitor the value of jitter calculated for the outbound, one-way, OAM ping requests sent for an OAM ping test run.

**roundtrip** — Monitor the value of jitter calculated for the round trip, two-way, OAM ping requests and replies for an OAM ping test run.

**Default** roundtrip

## trap-gen

**Syntax** trap-gen

**Context** config>saa>test

**Description** This command enables the context to configure trap generation for the SAA test.

## probe-fail-enable

**Syntax** [no] probe-fail-enable

**Context** config>saa>test>trap-gen

**Description** This command enables the generation of an SNMP trap when probe-fail-threshold consecutive probes fail during the execution of the SAA ping test. This command is not applicable to SAA trace route tests.

The **no** form of the command disables the generation of an SNMP trap.

## probe-fail-threshold

**Syntax** [no] probe-fail-threshold 0..15

**Context** config>saa>test>trap-gen

**Description** This command has no effect when probe-fail-enable is disabled. This command is not applicable to SAA trace route tests.

The **probe-fail-enable** command enables the generation of an SNMP trap when the probe-fail-threshold consecutive probes fail during the execution of the SAA ping test. This command is not applicable to SAA trace route tests.

The **no** form of the command returns the threshold value to the default.

**Default** 1

## test-completion-enable

**Syntax** [no] test-completion-enable

**Context** config>saa>test>trap-gen

**Description** This command enables the generation of a trap when an SAA test completes.  
The **no** form of the command disables the trap generation.

## test-fail-enable

**Syntax** [no] test-fail-enable

**Context** config>saa>test>trap-gen

**Description** This command enables the generation of a trap when a test fails. In the case of a ping test, the test is considered failed (for the purpose of trap generation) if the number of failed probes is at least the value of the **test-fail-threshold** parameter.  
The **no** form of the command disables the trap generation.

## test-fail-threshold

**Syntax** [no] test-fail-threshold 0..15

**Context** config>saa>test>trap-gen

**Description** This command configures the threshold for trap generation on test failure.  
This command has no effect when test-fail-enable is disabled. This command is not applicable to SAA trace route tests.  
The **no** form of the command returns the threshold value to the default.

**Default** 1

## type

**Syntax** type  
no type

**Context** config>saa>test

**Description** This command creates the context to provide the test type for the named test. Only a single test type can be configured.

A test can only be modified while the test is in shut down mode.

Once a test type has been configured the command can be modified by re-entering the command, the test type must be the same as the previously entered test type.

To change the test type, the old command must be removed using the **config>saa>test>no type** command.

## cpe-ping

Syntax	<b>cpe-ping service</b> <i>service-id</i> <b>destination</b> <i>ip-address</i> <i>source ip-address</i> [ <i>ttl vc-label-ttl</i> ] [ <b>return-control</b> ] [ <b>source-mac</b> <i>ieee-address</i> ] [ <b>fc</b> <i>fc-name</i> [ <b>profile</b> [ <i>in</i>   <i>out</i> ]]] [ <b>interval</b> <i>interval</i> ] [ <b>count</b> <i>send-count</i> ] [ <b>send-control</b> ]
Context	oam config>saa>test>type
Description	This ping utility determines the IP connectivity to a CPE within a specified VPLS service.
Parameters	<p><b>service</b> <i>service-id</i> — The service ID of the service to diagnose or manage.</p> <p><b>Values</b>     <i>service-id:</i>        1 — 2147483647                   <i>svc-name:</i>         64 characters maximum</p> <p><b>destination</b> <i>ip-address</i> — Specifies the IP address to be used as the destination for performing an OAM ping operations.</p> <p><b>source</b> <i>ip-address</i> — Specify an unused IP address in the same network that is associated with the VPLS.</p> <p><b>ttl</b> <i>vc-label-ttl</i> — The TTL value in the VC label for the OAM MAC request, expressed as a decimal integer.</p> <p><b>Default</b>     255</p> <p><b>Values</b>     1 — 255</p> <p><b>return-control</b> — Specifies the MAC OAM reply to a data plane MAC OAM request be sent using the control plane instead of the data plane.</p> <p><b>Default</b>     MAC OAM reply sent using the data plane.</p> <p><b>source-mac</b> <i>ieee-address</i> — Specify the source MAC address that will be sent to the CPE. If not specified or set to 0, the MAC address configured for the CPMCFM is used.</p> <p><b>fc-name</b> — The forwarding class of the MPLS echo request encapsulation.</p> <p><b>Default</b>     be</p> <p><b>Values</b>     be, l2, af, l1, h2, ef, h1, nc</p> <p><b>profile</b> {<i>in</i>   <i>out</i>} — The profile state of the MPLS echo request encapsulation.</p> <p><b>Default</b>     out</p> <p><b>interval</b> <i>interval</i> — The <b>interval</b> parameter in seconds, expressed as a decimal integer. This parameter is used to override the default request message send interval and defines the minimum amount</p>

of time that must expire before the next message request is sent.

If the **interval** is set to 1 second where the **timeout** value is set to 10 seconds, then the maximum time between message requests is 10 seconds and the minimum is 1 second. This depends upon the receipt of a message reply corresponding to the outstanding message request.

**Default** 1

**Values** 1 — 10

**count** *send-count* — The number of messages to send, expressed as a decimal integer. The **count** parameter is used to override the default number of message requests sent. Each message request must either timeout or receive a reply before the next message request is sent. The message **interval** value must be expired before the next message request is sent.

**Default** 1

**Values** 1 — 255

**send-control** — Specifies the MAC OAM request be sent using the control plane instead of the data plane.

**Default** MAC OAM request sent using the data plane.

## dns

<b>Syntax</b>	<b>dns target-addr</b> <i>dns-name</i> <b>name-server</b> <i>ip-address</i> [ <b>source</b> <i>ip-address</i> ] [ <b>count</b> <i>send-count</i> ] [ <b>timeout</b> <i>timeout</i> ] [ <b>interval</b> <i>interval</i> ]
<b>Context</b>	<GLOBAL> config>saa>test>type
<b>Description</b>	This command configures a DNS name resolution test.
<b>Parameters</b>	<p><b>target-addr</b> — The IP host address to be used as the destination for performing an OAM ping operation.</p> <p><i>dns-name</i> — The DNS name to be resolved to an IP address.</p> <p><b>name-server</b> <i>ip-address</i> — Specifies the server connected to a network that resolves network names into network addresses.</p> <p><b>source</b> <i>ip-address</i> — Specifies the IP address to be used as the source for performing an OAM ping operation.</p> <p><b>count</b> <i>send-count</i> — The number of messages to send, expressed as a decimal integer. The <b>send-count</b> parameter is used to override the default number of message requests sent. Each message request must either timeout or receive a reply before the next message request is sent. The message <b>interval</b> value must be expired before the next message request is sent.</p> <p><b>Default</b> 1</p> <p><b>Values</b> 1 — 100</p> <p><b>timeout</b> <i>timeout</i> — The <b>timeout</b> parameter in seconds, expressed as a decimal integer. This value is used to override the default <b>timeout</b> value and is the amount of time that the router will wait for</p>

a message reply after sending the message request. Upon the expiration of message timeout, the requesting router assumes that the message response will not be received. Any response received after the request times out will be silently discarded.

**Default** 5

**Values** 1 — 120

**interval** *interval* — The **interval** parameter in seconds, expressed as a decimal integer. This parameter is used to override the default request message send interval and defines the minimum amount of time that must expire before the next message request is sent.

If the **interval** is set to 1 second, and the **timeout** value is set to 10 seconds, then the maximum time between message requests is 10 seconds and the minimum is 1 second. This depends upon the receipt of a message reply corresponding to the outstanding message request.

**Default** 1

**Values** 1 — 10

## eth-cfm-linktrace

<b>Syntax</b>	<b>eth-cfm-linktrace</b> <i>mac-address</i> <b>mep</b> <i>mep-id</i> <b>domain</b> <i>md-index</i> <b>association</b> <i>ma-index</i> [ <b>ttl</b> <i>tll-value</i> ] [ <b>fc</b> { <i>fc-name</i> }] [ <b>profile</b> { <i>in out</i> }] [ <b>count</b> <i>send-count</i> ] [ <b>timeout</b> <i>timeout</i> ] [ <b>interval</b> <i>interval</i> ]
<b>Context</b>	config>saa>test>type
<b>Description</b>	This command configures a CFM linktrace test in SAA.
<b>Parameters</b>	<p><i>mac-address</i> — Specifies a unicast destination MAC address.</p> <p><b>mep</b> <i>mep-id</i> — Specifies the target MAC address.</p> <p><b>Values</b> 1 — 8191</p> <p><b>domain</b> <i>md-index</i> — Specifies the MD index.</p> <p><b>Values</b> 1 — 4294967295</p> <p><b>association</b> <i>ma-index</i> — Specifies the MA index.</p> <p><b>Values</b> 1 — 4294967295</p> <p><b>tll</b> <i>tll-value</i> — Specifies the maximum number of hops traversed in the linktrace.</p> <p><b>Default</b> 64</p> <p><b>Values</b> 1 — 255</p> <p><b>fc</b> <i>fc-name</i> — The <b>fc</b> parameter is used to indicate the forwarding class of the MPLS echo request packets. The actual forwarding class encoding is controlled by the network egress LSP-EXP mappings.</p> <p><b>Default</b> nc</p> <p><b>Values</b> be, l2, af, l1, h2, ef, h1, nc</p>

**profile** {**in** | **out**} — The profile state of the MPLS echo request encapsulation.

**Default** in

**count** *send-count* — The number of messages to send, expressed as a decimal integer. The **count** parameter is used to override the default number of message requests sent. Each message request must either timeout or receive a reply before the next message request is sent. The message **interval** value must be expired before the next message request is sent.

**Default** 1

**Values** 1 — 10

**timeout** *timeout* — The **timeout** parameter in seconds, expressed as a decimal integer. This value is used to override the default **timeout** value and is the amount of time that the router will wait for a message reply after sending the message request. Upon the expiration of message timeout, the requesting router assumes that the message response will not be received. Any response received after the request times out will be silently discarded. The **timeout** value must be less than the **interval**.

**Default** 5

**Values** 1 — 10

**interval** *interval* — The **interval** parameter in seconds, expressed as a decimal integer. This parameter is used to override the default request message send interval and defines the minimum amount of time that must expire before the next message request is sent.

If the **interval** is set to 1 second, and the **timeout** value is set to 10 seconds, then the maximum time between message requests is 10 seconds and the minimum is 1 second. This depends upon the receipt of a message reply corresponding to the outstanding message request. The **timeout** value must be less than the **interval**.

**Default** 5

**Values** 1 — 10

## eth-cfm-loopback

**Syntax** **eth-cfm-loopback** *mac-address* **mep** *mep-id* **domain** *md-index* **association** *ma-index* [**size** *data-size*] [**fc** {*fc-name*}] [**profile** {**in**|**out**}]] [**count** *send-count* ] [**timeout** *timeout*] [**interval** *interval*]

**Context** config>saa>test>type

**Description** This command configures an Ethernet CFM loopback test in SAA.

*mac-address* — Specifies a unicast destination MAC address.

**mep** *mep-id* — Specifies the target MAC address.

**Values** 1 — 8191

**domain** *md-index* — Specifies the MD index.

**Values** 1 — 4294967295

**association** *ma-index* — Specifies the MA index.

**Values** 1 — 4294967295

**size** *data-size* — The packet size in bytes, expressed as a decimal integer.

**Default** 0

**Values** 0 — 1500

**fc** *fc-name* — The **fc** parameter is used to indicate the forwarding class of the MPLS echo request packets. The actual forwarding class encoding is controlled by the network egress LSP-EXP mappings.

**Default** nc

**Values** be, l2, af, l1, h2, ef, h1, nc

**profile** {**in** | **out**} — The profile state of the MPLS echo request encapsulation.

**Default** in

**count** *send-count* — The number of messages to send, expressed as a decimal integer. The **count** parameter is used to override the default number of message requests sent. Each message request must either timeout or receive a reply before the next message request is sent. The message **interval** value must be expired before the next message request is sent.

**Default** 1

**Values** 1 — 100

**timeout** *timeout* — The **timeout** parameter in seconds, expressed as a decimal integer. This value is used to override the default **timeout** value and is the amount of time that the router will wait for a message reply after sending the message request. Upon the expiration of message timeout, the requesting router assumes that the message response will not be received. Any response received after the request times out will be silently discarded. The **timeout** value must be less than the **interval**.

**Default** 5

**Values** 1 — 10

**interval** *interval* — The **interval** parameter in seconds, expressed as a decimal integer. This parameter is used to override the default request message send interval and defines the minimum amount of time that must expire before the next message request is sent.

If the **interval** is set to 1 second, and the **timeout** value is set to 10 seconds, then the maximum time between message requests is 10 seconds and the minimum is 1 second. This depends upon the receipt of a message reply corresponding to the outstanding message request. The **timeout** value must be less than the **interval**.

**Default** 5

**Values** 1 — 10

## eth-cfm-two-way-delay

- Syntax** `eth-cfm-two-way-delay mac-address mep mep-id domain md-index association ma-index [fc {fc-name} [profile {in|out}] [count send-count] [timeout timeout] [interval interval]`
- Context** config>saa>test>type
- Description** This command configures an Ethernet CFM two-way delay test in SAA.
- mac-address* — Specifies a unicast destination MAC address.
- mep** *mep-id* — Specifies the target MAC address.
- Values** 1 — 8191
- domain** *md-index* — Specifies the MD index.
- Values** 1 — 4294967295
- association** *ma-index* — Specifies the MA index.
- Values** 1 — 4294967295
- fc** *fc-name* — The **fc** parameter is used to indicate the forwarding class of the MPLS echo request packets. The actual forwarding class encoding is controlled by the network egress LSP-EXP mappings.
- Default** nc
- Values** be, l2, af, l1, h2, ef, h1, nc
- profile** {*in | out*} — The profile state of the MPLS echo request encapsulation.
- Default** in
- count** *send-count* — The number of messages to send, expressed as a decimal integer. The **count** parameter is used to override the default number of message requests sent. Each message request must either timeout or receive a reply before the next message request is sent. The message **interval** value must be expired before the next message request is sent.
- Default** 1
- Values** 1 — 100
- timeout** *timeout* — The **timeout** parameter in seconds, expressed as a decimal integer. This value is used to override the default **timeout** value and is the amount of time that the router will wait for a message reply after sending the message request. Upon the expiration of message timeout, the requesting router assumes that the message response will not be received. Any response received after the request times out will be silently discarded. The **timeout** value must be less than the **interval**.
- Default** 5
- Values** 1 — 10
- interval** *interval* — The **interval** parameter in seconds, expressed as a decimal integer. This parameter is used to override the default request message send interval and defines the minimum amount of time that must expire before the next message request is sent.

If the **interval** is set to 1 second, and the **timeout** value is set to 10 seconds, then the maximum time between message requests is 10 seconds and the minimum is 1 second. This depends upon the receipt of a message reply corresponding to the outstanding message request. The **timeout** value must be less than the **interval**.

**Default** 5

**Values** 1 — 10

## icmp-ping

- Syntax** **icmp-ping** [*ip-address* | *dns-name*] [**rapid** | **detail**] [**ttl** *time-to-live*] [**tos** *type-of-service*] [**size** *bytes*] [**pattern** *pattern*] [**source** *ip-address* | *dns-name*] [**interval** *seconds*] [{**next-hop** *ip-address*} | {**interface** *interface-name*} | **bypass-routing**] [**count** *requests*] [**do-not-fragment**] [**router** *router-instance* | **service-name** *service-name*] [**timeout** *timeout*]
- Context** config>saa>test>type
- Description** This command configures an ICMP traceroute test.
- Parameters** *ip-address* — The far-end IP address to which to send the **svc-ping** request message in dotted decimal notation.
- Values** ipv4-address: a.b.c.d  
 ipv6-address: x:x:x:x:x:x:x  
 x:x:x:x:x:x:d.d.d.d  
 x: [0 — FFFF]H  
 d: [0 — 255]D
- dns-name* — The DNS name of the far-end device to which to send the **svc-ping** request message, expressed as a character string up to 63 characters maximum.
- Values** ipv6-address: x:x:x:x:x:x:x[-interface]  
 x:x:x:x:x:x:d.d.d.d[-interface]  
 x: [0 — FFFF]H  
 d: [0 — 255]D  
 interface (32 chars max, mandatory for link local addresses)
- rapid** — Packets will be generated as fast as possible instead of the default 1 per second.
- detail** — Displays detailed information.
- ttl** *time-to-live* — The TTL value for the MPLS label, expressed as a decimal integer.
- Values** 1 — 128
- tos** *type-of-service* — Specifies the service type.
- Values** 0 — 255
- size** *bytes* — The request packet size in bytes, expressed as a decimal integer.
- Values** 0 — 16384
- pattern** *pattern* — The data portion in a ping packet will be filled with the pattern value specified. If

not specified, position info will be filled instead.

**Values** 0 — 65535

**source** *ip-address|dns-name* — Specifies the IP address to be used.

**Values**

ipv4-address:	a.b.c.d
ipv6-address:	x:x:x:x:x:x:x
	x:x:x:x:x:d.d.d
x:	[0 — FFFF]H
d:	[0 — 255]D
dns-name:	128 characters max

**interval** *seconds* — This parameter is used to override the default request message send interval and defines the minimum amount of time that must expire before the next message request is sent.

If the **interval** is set to 1 second, and the **timeout** value is set to 10 seconds, then the maximum time between message requests is 10 seconds and the minimum is 1 second. This depends upon the receipt of a message reply corresponding to the outstanding message request.

**Default** 1

**Values** 1 — 10

**next-hop** *ip-address* — Only displays static routes with the specified next hop IP address.

**Values**

ipv4-address:	a.b.c.d (host bits must be 0)
ipv6-address:	x:x:x:x:x:x (eight 16-bit pieces)
	x:x:x:x:x:d.d.d
x:	[0 — FFFF]H
d:	[0 — 255]D

**interface** *interface-name* — The name used to refer to the interface. The name must already exist in the **config>router>interface** context.

**bypass-routing** — Specifies whether to send the ping request to a host on a directly attached network bypassing the routing table.

**count** *requests* — Specifies the number of times to perform an OAM ping probe operation. Each OAM echo message request must either timeout or receive a reply before the next message request is sent.

**Values** 1 — 100000

**Default** 5

**do-not-fragment** — Sets the DF (Do Not Fragment) bit in the ICMP ping packet.

**router** *router-instance* — Specifies the router name or service ID.

**Values**

<i>router-name:</i>	Base , management
<i>service-id:</i>	1 — 2147483647

**Default** Base

**service-name** *service-name* — Specifies the service name as an integer or string.

**Values**

<i>service-id:</i>	1 — 2147483647
<i>svc-name:</i>	64 characters maximum

**timeout** *timeout* — Overrides the default **timeout** value and is the amount of time that the router will wait for a message reply after sending the message request. Upon the expiration of message timeout, the requesting router assumes that the message response will not be received. Any response received after the request times out will be silently discarded.

**Default** 5

**Values** 1 — 10

## icmp-trace

<b>Syntax</b>	<b>icmp-trace</b> [ <i>ip-address</i>   <i>dns-name</i> ] [ <b>ttl</b> <i>time-to-live</i> ] [ <b>wait</b> <i>milli-seconds</i> ] [ <b>tos</b> <i>type-of-service</i> ] [ <b>source</b> <i>ip-address</i> ] [ <b>tos</b> <i>type-of-service</i> ] [ <b>router</b> <i>router-instance</i>   <b>service-name</b> <i>service-name</i> ]																				
<b>Context</b>	config>saa>test>type																				
<b>Description</b>	This command configures an ICMP traceroute test.																				
<b>Parameters</b>	<p><i>ip-address</i> — The far-end IP address to which to send the <b>svc-ping</b> request message in dotted decimal notation.</p> <p><b>Values</b></p> <table> <tr> <td>ipv4-address:</td> <td>a.b.c.d</td> </tr> <tr> <td>ipv6-address:</td> <td>x:x:x:x:x:x:x</td> </tr> <tr> <td></td> <td>x:x:x:x:x:x:d.d.d.d</td> </tr> <tr> <td>x:</td> <td>[0 — FFFF]H</td> </tr> <tr> <td>d:</td> <td>[0 — 255]D</td> </tr> </table> <p><i>dns-name</i> — The DNS name of the far-end device to which to send the <b>svc-ping</b> request message, expressed as a character string to 63 characters maximum.</p> <p><b>ttl</b> <i>time-to-live</i> — The TTL value for the MPLS label, expressed as a decimal integer.</p> <p><b>Values</b> 1 — 255</p> <p><b>wait</b> <i>milliseconds</i> — The time in milliseconds to wait for a response to a probe, expressed as a decimal integer.</p> <p><b>Default</b> 5000</p> <p><b>Values</b> 1 — 60000</p> <p><b>tos</b> <i>type-of-service</i> — Specifies the service type.</p> <p><b>Values</b> 0 — 255</p> <p><b>source</b> <i>ip-address</i> — Specifies the IP address to be used.</p> <p><b>Values</b></p> <table> <tr> <td>ipv4-address:</td> <td>a.b.c.d</td> </tr> <tr> <td>ipv6-address:</td> <td>x:x:x:x:x:x:x</td> </tr> <tr> <td></td> <td>x:x:x:x:x:x:d.d.d.d</td> </tr> <tr> <td>x:</td> <td>[0 — FFFF]H</td> </tr> <tr> <td>d:</td> <td>[0 — 255]D</td> </tr> </table>	ipv4-address:	a.b.c.d	ipv6-address:	x:x:x:x:x:x:x		x:x:x:x:x:x:d.d.d.d	x:	[0 — FFFF]H	d:	[0 — 255]D	ipv4-address:	a.b.c.d	ipv6-address:	x:x:x:x:x:x:x		x:x:x:x:x:x:d.d.d.d	x:	[0 — FFFF]H	d:	[0 — 255]D
ipv4-address:	a.b.c.d																				
ipv6-address:	x:x:x:x:x:x:x																				
	x:x:x:x:x:x:d.d.d.d																				
x:	[0 — FFFF]H																				
d:	[0 — 255]D																				
ipv4-address:	a.b.c.d																				
ipv6-address:	x:x:x:x:x:x:x																				
	x:x:x:x:x:x:d.d.d.d																				
x:	[0 — FFFF]H																				
d:	[0 — 255]D																				

**router** *router-instance* — Specifies the router name or service ID.

<b>Values</b>	<i>router-name:</i>	Base , management
	<i>service-id:</i>	1 — 2147483647
<b>Default</b>		Base

## Isp-ping

### Syntax

**Isp-ping** {[*isp-name*] [**path** *path-name*]} | {**prefix** *ip-prefix/mask*}} [**src-ip-address** *ip-addr*] [**fc** *fc-name*] [**profile** {*in* | *out*}] [**size** *octets*] [**ttl** *label-ttl*] [**send-count** *send-count*] [**timeout** *timeout*] [**interval** *interval*] [**path-destination** *ip-address*] [**interface** *if-name* | **next-hop** *ip-address*][**detail**]

### Context

oam  
config>saa>test>type

### Description

This command performs in-band LSP connectivity tests.

The **Isp-ping** command performs an LSP ping using the protocol and data structures defined in the RFC 4379, Detecting Multi-Protocol Label Switched (MPLS) Data Plane Failures.

The LSP ping operation is modeled after the IP ping utility which uses ICMP echo request and reply packets to determine IP connectivity.

In an LSP ping, the originating device creates an MPLS echo request packet for the LSP and path to be tested. The MPLS echo request packet is sent through the data plane and awaits an MPLS echo reply packet from the device terminating the LSP. The status of the LSP is displayed when the MPLS echo reply packet is received.

### Parameters

*isp-name* — Name that identifies an LSP to ping. The LSP name can be up to 32 characters long.

**path** *path-name* — The LSP path name along which to send the LSP ping request.

**Default** The active LSP path.

**Values** Any path name associated with the LSP.

**prefix** *ip-prefix/mask* — Specifies the address prefix and subnet mask of the destination node.

**src-ip-address** *ip-addr* — Specifies the source IP address. This option is used when an OAM packet must be generated from a different address than the node's system interface address. An example is when the OAM packet is sent over an LDP LSP and the LDP LSR-ID of the corresponding LDP session to the next-hop is set to an address other than the system interface address.

**Values** ipv4-address: a.b.c.d

**fc** *fc-name* — The **fc** parameter is used to indicate the forwarding class of the MPLS echo request packets. The actual forwarding class encoding is controlled by the network egress LSP-EXP mappings.

The LSP-EXP mappings on the receive network interface controls the mapping back to the internal forwarding class used by the far-end 7750 SR that receives the message request. The egress mappings of the egress network interface on the far-end 7750 SR controls the forwarding class markings on the return reply message.

The LSP-EXP mappings on the receive network interface controls the mapping of the message reply back at the originating router.

**Default** be

**Values** be, l2, af, l1, h2, ef, h1, nc

**src-ip-address** *ip-addr* — This parameter specifies the source IP address. This parameter is used when an OAM packet must be generated from a different address than the node's system interface address. For example, when the OAM packet is sent over an LDP LSP and the LDP LSR-ID of the corresponding LDP session to the next-hop is set to an address other than the system interface address.

**Values** ipv4-address: a.b.c.d

**profile** {*in* | *out*} — The profile state of the MPLS echo request encapsulation.

**Default** out

**size** *octets* — The MPLS echo request packet size in octets, expressed as a decimal integer. The request payload is padded with zeroes to the specified size.

**Default** 68 — The system sends the minimum packet size, depending on the type of LSP. No padding is added.

**Values** 84 — 65535

**ttl** *label-ttl* — The TTL value for the MPLS label, expressed as a decimal integer.

**Default** 255

**Values** 1 — 255

**send-count** *send-count* — The number of messages to send, expressed as a decimal integer. The **send-count** parameter is used to override the default number of message requests sent. Each message request must either timeout or receive a reply before the next message request is sent. The message **interval** value must be expired before the next message request is sent.

**Default** 1

**Values** 1 — 100

**timeout** *timeout* — The **timeout** parameter in seconds, expressed as a decimal integer. This value is used to override the default **timeout** value and is the amount of time that the router will wait for a message reply after sending the message request. Upon the expiration of message timeout, the requesting router assumes that the message response will not be received. Any response received after the request times out will be silently discarded.

**Default** 5

**Values** 1 — 10

**interval** *interval* — The **interval** parameter in seconds, expressed as a decimal integer. This parameter is used to override the default request message send interval and defines the minimum amount of time that must expire before the next message request is sent.

If the **interval** is set to 1 second, and the **timeout** value is set to 10 seconds, then the maximum time between message requests is 10 seconds and the minimum is 1 second. This depends upon the receipt of a message reply corresponding to the outstanding message request.

**Default** 1  
**Values** 1 — 10

**path-destination** *ip-address* — Specifies the IP address of the path destination.

**interface** *interface-name* — Specifies the name of an IP interface. The name must already exist in the **config>router>interface** context.

**next-hop** *ip-address* — Only displays static routes with the specified next hop IP address.

**Values**

ipv4-address:	a.b.c.d (host bits must be 0)
ipv6-address:	x:x:x:x:x:x:x (eight 16-bit pieces)
	x:x:x:x:x.d.d.d
x:	[0 — FFFF]H
d:	[0 — 255]D

## lsp-trace

### Syntax

**lsp-trace** {{{*lsp-name*} [**path** *path-name*]} | {**prefix** *ip-prefix/mask*}} [**src-ip-address** *ip-addr*] [**fc** *fc-name*] [**profile** {**in** | **out**}] [**max-fail** *no-response-count*] [**probe-count** *probes-per-hop*] [**size** *octets*][**min-ttl** *min-label-ttl*] [**max-ttl** *max-label-ttl*] [**timeout** *timeout*] [[**interval** *interval*] [**path-destination** *ip-address*] [**interface** *if-name* | **next-hop** *ip-address*]][**detail**]

### Context

oam  
 config>saa>test>type

### Description

This command displays the hop-by-hop path for an LSP.

The **lsp-trace** command performs an LSP traceroute using the protocol and data structures defined in the IETF draft (draft-ietf-mpls-lsp-ping-02.txt).

The LSP traceroute operation is modeled after the IP traceroute utility which uses ICMP echo request and reply packets with increasing TTL values to determine the hop-by-hop route to a destination IP.

In an LSP traceroute, the originating device creates an MPLS echo request packet for the LSP to be tested with increasing values of the TTL in the outermost label. The MPLS echo request packet is sent through the data plane and awaits a TTL exceeded response or the MPLS echo reply packet from the device terminating the LSP. The devices that reply to the MPLS echo request packets with the TTL exceeded and the MPLS echo reply are displayed.

### Parameters

*lsp-name* — Name that identifies an LSP to ping. The LSP name can be up to 32 characters long.

**path** *path-name* — The LSP pathname along which to send the LSP trace request.

**Default** The active LSP path.

**Values** Any path name associated with the LSP.

**prefix** *ip-prefix/mask* — Specifies the address prefix and subnet mask of the destination node.

**size** *octets* — The MPLS echo request packet size in octets, expressed as a decimal integer. The request payload is padded with zeroes to the specified size.

**Default** 68 — The system sends the minimum packet size, depending on the type of LSP. No padding is added.

**Values** 84 — 65535

**src-ip-address** *ip-addr* — Specifies the source IP address. This option is used when an OAM packet must be generated from a different address than the node's system interface address. An example is when the OAM packet is sent over an LDP LSP and the LDP LSR-ID of the corresponding LDP session to the next-hop is set to an address other than the system interface address.

**Values** ipv4-address: a.b.c.d

**min-ttl** *min-label-ttl* — The minimum TTL value in the MPLS label for the LSP trace test, expressed as a decimal integer.

**Default** 1

**Values** 1 — 255

**max-ttl** *max-label-ttl* — The maximum TTL value in the MPLS label for the LDP tree-trace test, expressed as a decimal integer.

**Default** 30

**Values** 1 — 255

**max-fail** *no-response-count* — The maximum number of consecutive MPLS echo requests, expressed as a decimal integer that do not receive a reply before the trace operation fails for a given TTL.

**Default** 5

**Values** 1 — 255

**send-count** *send-count* — The number of messages to send, expressed as a decimal integer. The **send-count** parameter is used to override the default number of message requests sent. Each message request must either timeout or receive a reply before the next message request is sent. The message **interval** value must be expired before the next message request is sent.

**Default** 1

**Values** 1 — 100

**timeout** *timeout* — The **timeout** parameter in seconds, expressed as a decimal integer. This value is used to override the default **timeout** value and is the amount of time that the 7750 SR will wait for a message reply after sending the message request. Upon the expiration of message timeout, the requesting router assumes that the message response will not be received. A 'request timeout' message is displayed by the CLI for each message request sent that expires. Any response received after the request times out will be silently discarded.

**Default** 3

**Values** 1 — 10

**interval** *interval* — The **interval** parameter in seconds, expressed as a decimal integer. This parameter is used to override the default request message send interval and defines the minimum amount of time that must expire before the next message request is sent.

If the **interval** is set to 1 second, and the **timeout** value is set to 10 seconds, then the maximum

time between message requests is 10 seconds and the minimum is 1 second. This depends upon the receipt of a message reply corresponding to the outstanding message request.

**Default** 1

**Values** 1 — 10

**fc** *fc-name* — The **fc** parameter is used to indicate the forwarding class of the MPLS echo request packets. The actual forwarding class encoding is controlled by the network egress LSP-EXP mappings.

The LSP-EXP mappings on the receive network interface controls the mapping back to the internal forwarding class used by the far-end 7750 SR that receives the message request. The egress mappings of the egress network interface on the far-end 7750 SR controls the forwarding class markings on the return reply message.

The LSP-EXP mappings on the receive network interface controls the mapping of the message reply back at the originating 7750 SR.

**Default** be

**Values** be, l2, af, l1, h2, ef, h1, nc

**profile** {**in** | **out**} — The profile state of the MPLS echo request encapsulation.

**Default** out

## mac-ping

- Syntax** **mac-ping service** *service-id* **destination** *dst-ieee-address* [**source** *src-ieee-address*] [**fc** *fc-name* [**profile** **in** | **out**]] [**size** *octets*] [**ttl** *vc-label-ttl*] [**count** *send-count*] [**send-control**] [**return-control**] [**interval** *interval*] [**timeout** *timeout*]
- Context** oam  
config>saa>test>type
- Description** The mac-ping utility is used to determine the existence of an egress SAP binding of a given MAC within a VPLS service.
- A **mac-ping** packet can be sent via the control plane or the data plane. The **send-control** option specifies the request be sent using the control plane. If **send-control** is not specified, the request is sent using the data plane.
- A **mac-ping** is forwarded along the flooding domain if no MAC address bindings exist. If MAC address bindings exist, then the packet is forwarded along those paths, provided they are active. A response is generated only when there is an egress SAP binding for that MAC address or if the MAC address is a “local” OAM MAC address associated with the device’s control plan.
- A **mac-ping** reply can be sent using the data plane or the control plane. The **return-control** option specifies the reply be sent using the control plane. If **return-control** is not specified, the request is sent using the data plane.
- A **mac-ping** with data plane reply can only be initiated on nodes that can have an egress MAC address binding. A node without a FIB and without any SAPs cannot have an egress MAC address

binding, so it is not a node where replies in the data plane will be trapped and sent up to the control plane.

A control plane request is responded to via a control plane reply only.

By default, MAC OAM requests are sent with the system or chassis MAC address as the source MAC. The **source** option allows overriding of the default source MAC for the request with a specific MAC address.

When a **source** *ieee-address* value is specified and the source MAC address is locally registered within a split horizon group (SHG), then this SHG membership will be used as if the packet originated from this SHG. In all other cases, SHG 0 (zero) will be used. Note that if the **mac-trace** is originated from a non-zero SHG, such packets will not go out to the same SHG.

If EMG is enabled, mac-ping will return only the first SAP in each chain.

### Parameters

**service** *service-id* — The service ID of the service to diagnose or manage.

**Values**     *service-id:*     1 — 2147483647  
                  *svc-name:*       64 characters maximum

**destination** *ieee-address* — The destination MAC address for the OAM MAC request.

**size** *octets* — The MAC OAM request packet size in octets, expressed as a decimal integer. The request payload is padded to the specified size with a 6 byte PAD header and a byte payload of 0xAA as necessary. If the octet size specified is less than the minimum packet, the minimum sized packet necessary to send the request is used.

**Default**     No OAM packet padding.

**Values**     1 — 65535

**ttl** *vc-label-ttl* — The TTL value in the VC label for the OAM MAC request, expressed as a decimal integer.

**Default**     255

**Values**     1 — 255

**send-control** — Specifies the MAC OAM request be sent using the control plane instead of the data plane.

**Default**     MAC OAM request sent using the data plane.

**return-control** — Specifies the MAC OAM reply to a data plane MAC OAM request be sent using the control plane instead of the data plane.

**Default**     MAC OAM reply sent using the data plane.

**source** *src-ieee-address* — The source MAC address from which the OAM MAC request originates. By default, the system MAC address for the chassis is used.

**Default**     The system MAC address.

**Values**     Any unicast MAC value.

**fc** *fc-name* — The **fc** parameter is used to test the forwarding class of the MPLS echo request packets. The actual forwarding class encoding is controlled by the network egress LSP-EXP mappings.

**Values**     be, l2, af, l1, h2, ef, h1, nc

**interval** *interval* — The **interval** parameter in seconds, expressed as a decimal integer. This parameter is used to override the default request message send interval and defines the minimum amount of time that must expire before the next message request is sent.

If the **interval** is set to 1 second where the **timeout** value is set to 10 seconds, then the maximum time between message requests is 10 seconds and the minimum is 1 second. This depends upon the receipt of a message reply corresponding to the outstanding message request.

**Default** 1

**Values** 1 — 10

**count** *send-count* — The number of messages to send, expressed as a decimal integer. The **count** parameter is used to override the default number of message requests sent. Each message request must either timeout or receive a reply before the next message request is sent. The message **interval** value must be expired before the next message request is sent.

**Default** 1

**Values** 1 — 100

**timeout** *timeout* — The **timeout** parameter in seconds, expressed as a decimal integer. This value is used to override the default **timeout** value and is the amount of time that the router will wait for a message reply after sending the message request. Upon the expiration of message timeout, the requesting router assumes that the message response will not be received. Any response received after the request times out will be silently discarded.

**Default** 5

**Values** 1 — 10

## sdp-ping

<b>Syntax</b>	<b>sdp-ping</b> <i>orig-sdp-id</i> [ <b>resp-sdp</b> <i>resp-sdp-id</i> ] [ <b>fc</b> <i>fc-name</i> [ <b>profile</b> { <b>in</b>   <b>out</b> }]] [ <b>timeout</b> <i>seconds</i> ] [ <b>interval</b> <i>seconds</i> ] [ <b>size</b> <i>octets</i> ] [ <b>count</b> <i>send-count</i> ]
<b>Context</b>	oam config>saa>test>type
<b>Description</b>	<p>This command tests SDPs for uni-directional or round trip connectivity and performs SDP MTU Path tests.</p> <p>The <b>sdp-ping</b> command accepts an originating SDP-ID and an optional responding SDP-ID. The size, number of requests sent, message time-out and message send interval can be specified. All <b>sdp-ping</b> requests and replies are sent with PLP OAM-Label encapsulation, as a <i>service-id</i> is not specified.</p> <p>For round trip connectivity testing, the <b>resp-sdp</b> keyword must be specified. If <b>resp-sdp</b> is not specified, a uni-directional SDP test is performed.</p> <p>To terminate an <b>sdp-ping</b> in progress, use the CLI break sequence &lt;Ctrl-C&gt;.</p> <p>An <b>sdp-ping</b> response message indicates the result of the <b>sdp-ping</b> message request. When multiple response messages apply to a single SDP echo request/reply sequence, the response message with the</p>

highest precedence will be displayed. The following table displays the response messages sorted by precedence.

Result of Request	Displayed Response Message	Precedence
Request timeout without reply	Request Timeout	1
Request not sent due to non-existent <i>orig-sdp-id</i>	Orig-SDP Non-Existent	2
Request not sent due to administratively down <i>orig-sdp-id</i>	Orig-SDP Admin-Down	3
Request not sent due to operationally down <i>orig-sdp-id</i>	Orig-SDP Oper-Down	4
Request terminated by user before reply or timeout	Request Terminated	5
Reply received, invalid <i>origination-id</i>	Far End: Originator-ID Invalid	6
Reply received, invalid <i>responder-id</i>	Far End: Responder-ID Error	7
Reply received, non-existent <i>resp-sdp-id</i>	Far End: Resp-SDP Non-Existent	8
Reply received, invalid <i>resp-sdp-id</i>	Far End: Resp-SDP Invalid	9
Reply received, <i>resp-sdp-id</i> down (admin or oper)	Far-end: Resp-SDP Down	10
Reply received, No Error	Success	11

**Parameters** *orig-sdp-id* — The SDP-ID to be used by **sdp-ping**, expressed as a decimal integer. The far-end address of the specified SDP-ID is the expected *responder-id* within each reply received. The specified SDP-ID defines the encapsulation of the SDP tunnel encapsulation used to reach the far end. This can be IP/GRE or MPLS. If *orig-sdp-id* is invalid or administratively down or unavailable for some reason, the SDP Echo Request message is not sent and an appropriate error message is displayed (once the **interval** timer expires, sdp-ping will attempt to send the next request if required).

**Values** 1 — 17407

**resp-sdp** *resp-sdp-id* — Optional parameter is used to specify the return SDP-ID to be used by the far-end 7750 SR for the message reply for round trip SDP connectivity testing. If *resp-sdp-id* does not exist on the far-end 7750 SR, terminates on another 7750 SR different than the originating 7750 SR, or another issue prevents the far-end router from using *resp-sdp-id*, the SDP echo reply will be sent using generic IP/GRE OAM encapsulation. The received forwarding class (as mapped on the ingress network interface for the far end) defines the forwarding class encapsulation for the reply message.

**Default** null. Use the non-SDP return path for message reply.

**Values** 1 — 17407

**fc** *fc-name* — The **fc** parameter is used to indicate the forwarding class of the SDP encapsulation. The actual forwarding class encoding is controlled by the network egress DSCP or LSP-EXP mappings.

The DSCP or LSP-EXP mappings on the receive network interface controls the mapping back to

the internal forwarding class used by the far-end 7750 SR that receives the message request. The egress mappings of the egress network interface on the far-end 7750 SR controls the forwarding class markings on the return reply message.

The DSCP or LSP-EXP mappings on the receive network interface controls the mapping of the message reply back at the originating 7750 SR. This is displayed in the response message output upon receipt of the message reply.

**Default**     be

**Values**     be, l2, af, ll, h2, ef, h1, nc

**profile {in | out}** — The profile state of the SDP encapsulation.

**Default**     out

**timeout seconds** — The **timeout** parameter in seconds, expressed as a decimal integer. This value is used to override the default **timeout** value and is the amount of time that the router will wait for a message reply after sending the message request. Upon the expiration of message timeout, the requesting router assumes that the message response will not be received. A ‘request timeout’ message is displayed by the CLI for each message request sent that expires. Any response received after the request times out will be silently discarded.

**Default**     5

**Values**     1 — 10

**interval seconds** — The **interval** parameter in seconds, expressed as a decimal integer. This parameter is used to override the default request message send interval and defines the minimum amount of time that must expire before the next message request is sent.

If the **interval** is set to 1 second, and the **timeout** value is set to 10 seconds, then the maximum time between message requests is 10 seconds and the minimum is 1 second. This depends upon the receipt of a message reply corresponding to the outstanding message request.

**Default**     1

**Values**     1 — 10

**size octets** — The **size** parameter in octets, expressed as a decimal integer. This parameter is used to override the default message size for the **sdp-ping** request. Changing the message size is a method of checking the ability of an SDP to support a **path-mtu**. The size of the message does not include the SDP encapsulation, VC-Label (if applied) or any DLC headers or trailers.

When the OAM message request is encapsulated in an IP/GRE SDP, the IP ‘DF’ (Do Not Fragment) bit is set. If any segment of the path between the sender and receiver cannot handle the message size, the message is discarded. MPLS LSPs are not expected to fragment the message either, as the message contained in the LSP is not an IP packet.

**Default**     40

**Values**     40 — 9198

**count send-count** — The number of messages to send, expressed as a decimal integer. The **count** parameter is used to override the default number of message requests sent. Each message request must either timeout or receive a reply before the next message request is sent. The message **interval** value must be expired before the next message request is sent.

**Default** 1  
**Values** 1 — 100

**Special Cases** Single Response Connectivity Tests — A single response sdp-ping test provides detailed test results. Upon request timeout, message response, request termination, or request error the following local and remote information will be displayed. Local and remote information will be dependent upon SDP-ID existence and reception of reply.

Field	Description	Values
Request Result	The result of the <b>sdp-ping</b> request message.	Sent - Request Timeout Sent - Request Terminated Sent - Reply Received Not Sent - Non-Existent Local SDP-ID Not Sent - Local SDP-ID Down
Originating SDP-ID	The originating SDP-ID specified by <b>orig-sdp</b> .	<i>orig-sdp-id</i>
Originating SDP-ID Administrative State	The local administrative state of the originating SDP-ID. If the SDP-ID has been shutdown, Admin-Down is displayed. If the originating SDP-ID is in the no shutdown state, Admin-Up is displayed. If the <i>orig-sdp-id</i> does not exist, Non-Existent is displayed.	Admin-Up Admin-Down Non-Existent
Originating SDP-ID Operating State	The local operational state of the originating SDP-ID. If <i>orig-sdp-id</i> does not exist, N/A will be displayed.	Oper-Up Oper-Down N/A
Originating SDP-ID Path MTU	The local <b>path-mtu</b> for <i>orig-sdp-id</i> . If <i>orig-sdp-id</i> does not exist locally, N/A is displayed.	<i>orig-path-mtu</i> N/A
Responding SDP-ID	The SDP-ID requested as the far-end path to respond to the <b>sdp-ping</b> request. If <b>resp-sdp</b> is not specified, the responding router will not use an SDP-ID as the return path and N/A will be displayed.	<i>resp-sdp-id</i> N/A
Responding SDP-ID Path Used	Displays whether the responding 7750 SR used the responding <i>sdp-id</i> to respond to the <b>sdp-ping</b> request. If <i>resp-sdp-id</i> is a valid, operational SDP-ID, it must be used for the SDP echo reply message. If the far-end uses the responding <i>sdp-id</i> as the return path, Yes will be displayed. If the far-end does not use the responding <i>sdp-id</i> as the return path, No will be displayed. If <b>resp-sdp</b> is not specified, N/A will be displayed.	Yes No N/A

Field	Description	Values
Responding SDP-ID Administrative State	The administrative state of the responding <i>sdp-id</i> . When <i>resp-sdp-id</i> is administratively down, Admin-Down will be displayed. When <i>resp-sdp-id</i> is administratively up, Admin-Up will be displayed. When <i>resp-sdp-id</i> exists on the far-end 7750 SR but is not valid for the originating router, Invalid is displayed. When <i>resp-sdp-id</i> does not exist on the far-end router, Non-Existent is displayed. When <b>resp-sdp</b> is not specified, N/A is displayed.	Admin-Down Admin-Up Invalid Non-Existent N/A
Responding SDP-ID Operational State	The operational state of the far-end <i>sdp-id</i> associated with the return path for <i>service-id</i> . When a return path is operationally down, Oper-Down is displayed. If the return <i>sdp-id</i> is operationally up, Oper-Up is displayed. If the responding <i>sdp-id</i> is non-existent, N/A is displayed.	Oper-Up Oper-Down N/A
Responding SDP-ID Path MTU	The remote <b>path-mtu</b> for <i>resp-sdp-id</i> . If <i>resp-sdp-id</i> does not exist remotely, N/A is displayed	<i>resp-path-mtu</i> N/A
Local Service IP Address	The local system IP address used to terminate remotely configured <i>sdp-ids</i> (as the <i>sdp-id</i> <b>far-end</b> address). If an IP address has not been configured to be the system IP address, N/A is displayed.	<i>system-ip-addr</i> N/A
Local Service IP Interface Name	The name of the local system IP interface. If the local system IP interface has not been created, N/A is displayed.	<i>system-interface-name</i> N/A
Local Service IP Interface State	The state of the local system IP interface. If the local system IP interface has not been created, Non-Existent is displayed.	Up Down Non-Existent
Expected Far End Address	The expected IP address for the remote system IP interface. This must be the <b>far-end</b> address configured for the <i>orig-sdp-id</i> .	<i>orig-sdp-far-end-addr</i> <i>dest-ip-addr</i> N/A
Actual Far End Address	The returned remote IP address. If a response is not received, the displayed value is N/A. If the far-end service IP interface is down or non-existent, a message reply is not expected.	<i>resp-ip-addr</i> N/A
Responders Expected Far End Address	The expected source of the originators <i>sdp-id</i> from the perspective of the remote 7750 SR terminating the <i>sdp-id</i> . If the far-end cannot detect the expected source of the ingress <i>sdp-id</i> , N/A is displayed.	<i>resp-rec-tunnel-far-end-addr</i> N/A
Round Trip Time	The round trip time between SDP echo request and the SDP echo reply. If the request is not sent, times out or is terminated, N/A is displayed.	<i>delta-request-reply</i> N/A

**Single Response Round Trip Connectivity Test Sample Output**

```
A:router1> sdp-ping 10 resp-sdp 22 fc ef
Request Result: Sent - Reply Received
RTT: 30ms
```

```
Err SDP-ID Info      Local  Remote
__  SDP-ID:          10    22
__  Administrative State: Up    Up
__  Operative State:   Up    Up
__  Path MTU         4470   4470
__  Response SDP Used:      Yes
```

```
Err System IP Interface Info
Local Interface Name: "ESR-System-IP-Interface (Up to 32 chars)..."
__  Local IP Interface State:   Up
__  Local IP Address:          10.10.10.11
__  IP Address Expected By Remote: 10.10.10.11
__  Expected Remote IP Address:  10.10.10.10
__  Actual Remote IP Address:    10.10.10.10
```

```
Err FC Mapping Info  Local  Remote
__  Forwarding Class  Assured Assured
__  Profile           In     In
```

Multiple Response Connectivity Tests — When the connectivity test count is greater than one (1), a single line is displayed per SDP echo request send attempt.

The request number is a sequential number starting with 1 and ending with the last request sent, incrementing by one (1) for each request. This should not be confused with the *message-id* contained in each request and reply message.

A response message indicates the result of the message request. Following the response message is the round trip time value. If any reply is received, the round trip time is displayed.

After the last reply has been received or response timed out, a total is displayed for all messages sent and all replies received. A maximum, minimum and average round trip time is also displayed. Error response and timed out requests do not apply towards the average round trip time.

**Multiple Response Round Trip Connectivity Test Sample Output**

```
A:router1> sdp-ping 6 resp-sdp 101size 1514 count 5
Request  Response  RTT
-----  -
1       Success   10ms
2       Success   15ms
3       Success   10ms
4       Success   20ms
5       Success   5ms
Sent: 5  Received: 5
Min: 5ms  Max: 20ms  Avg: 12ms
```

## vccv-ping

<b>Syntax</b>	<b>vccv-ping</b> <i>sdp-id:vc-id</i> [ <b>src-ip-address</b> <i>ip-addr</i> <b>dst-ip-address</b> <i>ip-addr</i> <b>pw-id</b> <i>pw-id</i> ][ <b>reply-mode</b> { <b>ip-routed</b>   <b>control-channel</b> }] [ <b>fc</b> <i>fc-name</i> [ <b>profile</b> { <b>in</b>   <b>out</b> }]] [ <b>size</b> <i>octets</i> ] [ <b>count</b> <i>send-count</i> ] [ <b>timeout</b> <i>timeout</i> ] [ <b>interval</b> <i>interval</i> ] [ <b>ttl</b> <i>vc-label-ttl</i> ]
<b>Context</b>	oam config>saa>test
<b>Description</b>	<p>This command configures a Virtual Circuit Connectivity Verification (VCCV) ping test. A vccv-ping test checks connectivity of a VLL inband. It checks to verify that the destination (target) PE is the egress for the Layer 2 FEC. It provides for a cross-check between the dataplane and the control plane. It is inband which means that the vccv-ping message is sent using the same encapsulation and along the same path as user packets in that VLL. The vccv-ping test is the equivalent of the lsp-ping test for a VLL service. The vccv-ping reuses an lsp-ping message format and can be used to test a VLL configured over both an MPLS and a GRE SDP.</p> <p>Note that VCCV ping can be initiated on TPE or SPE. If initiated on the SPE, the <b>reply-mode</b> parameter must be used with the ip-routed value. The ping from the TPE can have either values or can be omitted, in which case the default value is used.</p> <p>If a VCCV ping is initiated from TPE to neighboring a SPE (one segment only) it is sufficient to only use the <i>sdpid:vcid</i> parameter. However, if the ping is across two or more segments, at least the <i>sdpId:vcId</i>, <b>src-ip-address</b> <i>ip-addr</i>, <b>dst-ip-address</b> <i>ip-addr</i>, <b>ttl</b> <i>vc-label-ttl</i> and <b>pw-id</b> <i>pw-id</i> parameters are used where:</p> <ul style="list-style-type: none"> <li>• The <i>src-ip-address</i> is system IP address of the router preceding the destination router.</li> <li>• The <i>pwid</i> is actually the VC ID of the last pseudowire segment.</li> <li>• The <i>vc-label-ttl</i> must have a value equal or higher than the number of pseudowire segments.</li> </ul> <p>Note that VCCV ping is a multi-segment pseudowire. For a single-hop pseudowire, only the peer VCCV CC bit of the control word is advertised when the control word is enabled on the pseudowire. VCCV ping on multi-segment pseudowires require that the control word be enabled in all segments of the VLL.</p> <p>If the control word is not enabled on spoke SDP it will not be signaled peer VCCV CC bits to the far end, consequently VCCV ping cannot be successfully initiated on that specific spoke SDP.</p>
<b>Parameters</b>	<p><i>sdp-id:vc-id</i> — The VC ID of the pseudowire being tested must be indicated with this parameter. The VC ID needs to exist on the local router and the far-end peer needs to indicate that it supports VCCV to allow the user to send vccv-ping message.</p> <p><b>Values</b>     1 — 17407:1 — 4294967295</p> <p><b>src-ip-address</b> <i>ip-addr</i> — Specifies the source IP address.</p> <p><b>Values</b>     ipv4-address:     a.b.c.d</p> <p><b>dst-ip-address</b> <i>ip-address</i> — Specifies the destination IP address.</p> <p><b>Values</b>     ipv4-address:     a.b.c.d</p> <p><b>pw-id</b> <i>pw-id</i> — Specifies the pseudowire ID to be used for performing a <b>vccv-ping</b> operation. The pseudowire ID is a non-zero 32-bit connection ID required by the FEC 128, as defined in RFC 4379, <i>Detecting Multi-Protocol Label Switched (MPLS) Data Plane Failures</i>.</p>

**reply-mode** {**ip-routed** | **control-channel**} — The reply-mode parameter indicates to the far-end how to send the reply message. The option control-channel indicates a reply mode in-band using vccv control channel.

**Default** control-channel

**fc fc-name** — The **fc** parameter is used to indicate the forwarding class of the MPLS echo request packets. The actual forwarding class encoding is controlled by the network egress LSP-EXP mappings.

The LSP-EXP mappings on the receive network interface controls the mapping back to the internal forwarding class used by the far-end 7750 SR that receives the message request. The egress mappings of the egress network interface on the far-end router controls the forwarding class markings on the return reply message. The LSP-EXP mappings on the receive network interface controls the mapping of the message reply back at the originating SR.

**Default** be

**Values** be, l2, af, l1, h2, ef, h1, nc

**profile** {**in** | **out**} — The profile state of the MPLS echo request encapsulation.

**Default** out

**timeout seconds** — The timeout parameter, in seconds, expressed as a decimal integer. This value is used to override the default timeout value and is the amount of time that the router will wait for a message reply after sending the message request. Upon the expiration of message timeout, the requesting router assumes that the message response will not be received. A ‘request timeout’ message is displayed by the CLI for each message request sent that expires. Any response received after the request times out will be silently discarded.

**Default** 5

**Values** 1 — 10

**interval seconds** — The interval parameter in seconds, expressed as a decimal integer. This parameter is used to override the default request message send interval and defines the minimum amount of time that must expire before the next message request is sent.

If the interval is set to 1 second, and the timeout value is set to 10 seconds, then the maximum time between message requests is 10 seconds and the minimum is 1 second. This depends upon the receipt of a message reply corresponding to the outstanding message request.

**Default** 1

**Values** 1 — 10

**size octets** — The VCCV ping echo request packet size in octets, expressed as a decimal integer. The request payload is padded with zeroes to the specified size.

**Default** 88

**Values** 88 — 9198

**count send-count** — The number of messages to send, expressed as a decimal integer. The count parameter is used to override the default number of message requests sent. Each message request must either timeout or receive a reply before the next message request is sent. The message interval value must be expired before the next message request is sent.

**Default** 1  
**Values** 1 — 100

**t**tl *vc-label-ttl* — Specifies the time-to-live value for the vc-label of the echo request message. The outer label TTL is still set to the default of 255 regardless of this value.

**Sample Output**

```
Ping TPE to SPE on a LDP/GRE tunnel
=====

*A:Dut-B# oam vccv-ping 3:1
VCCV-PING 3:1 88 bytes MPLS payload
Seq=1, send from intf toSPE1-D-8 to NH 12.1.8.2
      reply from 4.4.4.4 via Control Channel
      udp-data-len=56 rtt=0.689ms rc=8 (DSRtrMatchLabel)

---- VCCV PING 3:1 Statistics ----
1 packets sent, 1 packets received, 0.00% packet loss
round-trip min = 0.689ms, avg = 0.689ms, max = 0.689ms, stddev = 0.000ms

Ping TPE to SPE on a RSVP tunnel
=====

A:Dut-C# oam vccv-ping 5:1
VCCV-PING 5:1 88 bytes MPLS payload
Seq=1, send from intf toSPE2-E-5 to NH 12.3.5.1
      send from lsp toSPE2-E-5
      reply from 5.5.5.5 via Control Channel
      udp-data-len=56 rtt=1.50ms rc=8 (DSRtrMatchLabel)

---- VCCV PING 5:1 Statistics ----
1 packets sent, 1 packets received, 0.00% packet loss
round-trip min = 1.50ms, avg = 1.50ms, max = 1.50ms, stddev = 0.000ms

Ping TPE to TPE over multisegment pseudowire
=====
*A:Dut-C# oam vccv-ping 5:1 src-ip-address 4.4.4.4 dst-ip-address 2.2.2.2 pw-id 1 ttl
3
VCCV-PING 5:1 88 bytes MPLS payload
Seq=1, send from intf toSPE2-E-5 to NH 12.3.5.1
      send from lsp toSPE2-E-5
      reply from 2.2.2.2 via Control Channel
      udp-data-len=32 rtt=2.50ms rc=3 (EgressRtr)

---- VCCV PING 5:1 Statistics ----
1 packets sent, 1 packets received, 0.00% packet loss
round-trip min = 2.50ms, avg = 2.50ms, max = 2.50ms, stddev = 0.000ms

Ping SPE to TPE (over LDP tunnel)
=====

Single segment:
-----
```

```

*A:Dut-D# oam vccv-ping 3:1 reply-mode ip-routed
VCCV-PING 3:1 88 bytes MPLS payload
Seq=1, send from intf toTPE1-B-8 to NH 12.1.8.1
      reply from 2.2.2.2 via IP
      udp-data-len=32 rtt=1.66ms rc=3 (EgressRtr)

---- VCCV PING 3:1 Statistics ----
1 packets sent, 1 packets received, 0.00% packet loss
round-trip min = 1.66ms, avg = 1.66ms, max = 1.66ms, stddev = 0.000ms

Multisegment:
-----
*A:Dut-D>config>router# oam vccv-ping 4:200 src-ip-address 5.5.5.5 dst-ip-address
3.3.3.3 pw-id 1 ttl 2 reply-mode ip-routed
VCCV-PING 4:200 88 bytes MPLS payload
Seq=1, send from intf toSPE2-E-5 to NH 12.2.5.2
      reply from 3.3.3.3 via IP
      udp-data-len=32 rtt=3.76ms rc=3 (EgressRtr)

---- VCCV PING 4:200 Statistics ----
1 packets sent, 1 packets received, 0.00% packet loss
round-trip min = 3.76ms, avg = 3.76ms, max = 3.76ms, stddev = 0.000ms

Ping SPE to SPE
=====
*A:Dut-D# oam vccv-ping 4:200 reply-mode ip-routed
VCCV-PING 4:200 88 bytes MPLS payload
Seq=1, send from intf toSPE2-E-5 to NH 12.2.5.2
      reply from 5.5.5.5 via IP
      udp-data-len=56 rtt=1.77ms rc=8 (DSRtrMatchLabel)

---- VCCV PING 4:200 Statistics ----
1 packets sent, 1 packets received, 0.00% packet loss
round-trip min = 1.77ms, avg = 1.77ms, max = 1.77ms, stddev = 0.000ms

```

## vccv-trace

- Syntax** `vccv-trace sdp-id:vc-id [fc fc-name [profile {in | out}]] [size octets] [reply-mode ip-routed|control-channel] [probe-count probes-per-hop] [timeout timeout] [interval interval] [min-ttl min-vc-label-ttl] [max-ttl max-vc-label-ttl] [max-fail no-response-count] [detail]`
- Context** oam  
config>saa>test>type
- Description** This command configures a Virtual Circuit Connectivity Verification (VCCV) automated trace test. The automated VCCV-trace can trace the entire path of a PW with a single command issued at the T-PE or at an S-PE. This is equivalent to LSP-Trace and is an iterative process by which the source T-PE or S-PE node sends successive VCCV-Ping messages with incrementing the TTL value, starting from TTL=1.
- In each iteration, the T-PE builds the MPLS echo request message in a way similar to vccv-ping. The first message with TTL=1 will have the next-hop S-PE T-LDP session source address in the Remote

PE Address<sup>1</sup> field in the PW FEC TLV. Each S-PE which terminates and processes the message will include in the MPLS echo reply message the FEC 128 TLV corresponding the PW segment to its downstream node. The source T-PE or S-PE node can then build the next echo reply message with TTL=2 to test the next-next hop for the MS-PW. It will copy the FEC TLV it received in the echo reply message into the new echo request message. The process is terminated when the reply is from the egress T-PE or when a timeout occurs.

The user can specify to display the result of the VCCV-trace for a fewer number of PW segments of the end-to-end MS-PW path. In this case, the min-ttl and max-ttl parameters are configured accordingly. However, the T-PE/S-PE node will still probe all hops up to min-ttl in order to correctly build the FEC of the desired subset of segments.

**Parameters** *sdpid:vcid* — The VC ID of the pseudowire being tested must be indicated with this parameter. The VC ID needs to exist on the local 7750 SR and the far-end peer needs to indicate that it supports VCCV to allow the user to send vccv-ping message.

**Values** 1-17407:1 — 4294967295

**reply-mode** {*ip-routed* | *control-channel*} — The reply-mode parameter indicates to the far-end how to send the reply message. The option control-channel indicates a reply mode in-band using vccv control channel.

Note that when a VCCV trace message is originated from an S-PE node, the user should use the IPv4 reply mode as the replying node does not know how to set the TTL to reach the sending S-PE node. If the user attempts this, a warning is issued to use the ipv4 reply mode.

**Default** control-channel

**fc** *fc-name* [**profile** {*in* | *out*}] — The fc and profile parameters are used to indicate the forwarding class of the VCCV trace echo request packets. The actual forwarding class encoding is controlled by the network egress LSP-EXP mappings.

The LSP-EXP mappings on the receive network interface controls the mapping back to the internal forwarding class used by the far-end router that receives the message request. The egress mappings of the egress network interface on the far-end router controls the forwarding class markings on the return reply message. The LSP-EXP mappings on the receive network interface controls the mapping of the message reply back at the originating router.

*fc-name* — The forwarding class of the VCCV trace echo request encapsulation.

**Default** be

**Values** be, l2, af, l1, h2, ef, h1, nc

**profile** {*in* | *out*} — The profile state of the VCCV trace echo request encapsulation.

**Default** out

**size** *octets* — The VCCV ping echo request packet size in octets, expressed as a decimal integer. The request payload is padded with zeroes to the specified size.

**Default** 88

**Values** 88 — 9198

**probe-count** *probes-per-hop* — The number of VCCV trace echo request messages to send per TTL value.

**Default** 1

**Values** 1 — 10

**timeout** *timeout* — The timeout parameter in seconds, expressed as a decimal integer. This value is used to override the default timeout value and is the amount of time that the router will wait for a message reply after sending the message request. Upon the expiration of message timeout, the requesting router assumes that the message response will not be received. A request timeout message is displayed by the CLI for each message request sent that expires. Any response received after the request times out will be silently discarded.

**Default** 3

**Values** 1 — 60

**interval** *interval* — The interval parameter in seconds, expressed as a decimal integer. This parameter is used to override the default request message send interval and defines the minimum amount of time that must expire before the next message request is sent.

If the interval is set to 1 second, and the timeout value is set to 10 seconds, then the maximum time between message requests is 10 seconds and the minimum is 1 second. This depends upon the receipt of a message reply corresponding to the outstanding message request.

**Default** 1

**Values** 1 — 255

**min-ttl** *min-vc-label-ttl* — The TTL value for the VC label of the echo request message for the first hop of the MS-PW for which the results are to be displayed. This is expressed as a decimal integer. Note that the outer label TTL is still set to the default of 255 regardless of the value of the VC label.

**Default** 1

**Values** 1 — 255

**max-ttl** *max-vc-label-ttl* — The TTL value for the VC label of the echo request message for the last hop of the MS-PW for which the results are to be displayed. This is expressed as a decimal integer. Note that the outer label TTL is still set to the default of 255 regardless of the value of the VC label.

**Default** 8

**Values** 1 — 255

**max-fail** *no-response-count* — The maximum number of consecutive VCCV trace echo requests, expressed as a decimal integer that do not receive a reply before the trace operation fails for a given TTL value.

**Default** 5

**Values** 1 — 255

### Sample Output

```
*A:138.120.214.60# oam vccv-trace 1:33
VCCV-TRACE 1:33 with 88 bytes of MPLS payload
1 1.1.63.63 rtt<10ms rc=8(DSRtrMatchLabel)
```

```
2 1.1.62.62 rtt<10ms rc=8(DSRtrMatchLabel)
3 1.1.61.61 rtt<10ms rc=3(EgressRtr)
```

### Trace with detail:

```
*A:138.120.214.60>oam vccv-trace 1:33 detail
```

```
VCCV-TRACE 1:33 with 88 bytes of MPLS payload
```

```
1 1.1.63.63 rtt<10ms rc=8(DSRtrMatchLabel)
   Next segment: VcId=34 VcType=AAL5SSDU Source=1.1.63.63 Remote=1.1.62.62
2 1.1.62.62 rtt<10ms rc=8(DSRtrMatchLabel)
   Next segment: VcId=35 VcType=AAL5SSDU Source=1.1.62.62 Remote=1.1.61.61
3 1.1.61.61 rtt<10ms rc=3(EgressRtr)
```

```
SAA:
```

```
*A:multisim3>config>saa# info
```

```
-----
      test "vt1"
          shutdown
          type
              vccv-trace 1:2 fc "af" profile in timeout 2 interval 3 size 200
min-ttl 2 max-ttl 5 max-fail 2 probe-count 3
          exit
      exit
..
```

```
-----
*A:multisim3>config>saa#
```

---

## OAM SAA Commands

### saa

<b>Syntax</b>	<b>saa</b> <i>test-name</i> [ <b>owner</b> <i>test-owner</i> ] { <b>start</b>   <b>stop</b> } [ <b>no-accounting</b> ]
<b>Context</b>	oam
<b>Description</b>	<p>Use this command to start or stop an SAA test.</p> <p><i>test-name</i> — Name of the SAA test. The test name must already be configured in the <b>config&gt;saa&gt;test</b> context.</p> <p><b>owner</b> <i>test-owner</i> — Specifies the owner of an SAA operation up to 32 characters in length.</p> <p><b>Values</b> If a <i>test-owner</i> value is not specified, tests created by the CLI have a default owner “TiMOS CLI”.</p> <p><b>start</b> — This keyword starts the test. A test cannot be started if the same test is still running.</p> <p>A test cannot be started if it is in a shut-down state. An error message and log event will be generated to indicate a failed attempt to start an SAA test run. A test cannot be started if it is in a continuous state.</p> <p><b>stop</b> — This keyword stops a test in progress. A test cannot be stopped if it is not in progress. A log message will be generated to indicate that an SAA test run has been aborted. A test cannot be stopped if it is in a continuous state.</p> <p><b>no-accounting</b> — This parameter disables the recording results in the accounting policy. When specifying <b>no-accounting</b> then the MIB record produced at the end of the test will not be added to the accounting file. It will however use up one of the three MIB rows available for the accounting module to be collected.</p>

---

## LDP TreeTrace Commands

### ldp-treetrace

<b>Syntax</b>	<b>ldp-treetrace</b> { <b>prefix</b> <i>ip-prefix/mask</i> } [ <b>max-ttl</b> <i>ttl-value</i> ] [ <b>max-path</b> <i>max-paths</i> ] [ <b>timeout</b> <i>timeout</i> ] [ <b>retry-count</b> <i>retry-count</i> ] [ <b>fc</b> <i>fc-name</i> ] [ <b>profile</b> <i>profile</i> ]
<b>Context</b>	oam
<b>Description</b>	This command enables the context to configure LDP treeTrace parameters to perform Alcatel-Lucent OAM tree trace test operations manually.
<b>Parameters</b>	<p><b>prefix</b> <i>ip-prefix/mask</i> — Specifies the address prefix and subnet mask of the destination node.</p> <p><b>max-ttl</b> <i>max-label-ttl</i> — The maximum TTL value in the MPLS label for the LSP trace test, expressed as a decimal integer.</p> <p><b>Default</b> 30</p> <p><b>Values</b> 1 — 255</p> <p><b>max-paths</b> <i>max-paths</i> — The maximum number of paths for a ldp-treetrace test, expressed as a decimal integer.</p> <p><b>Default</b> 128</p> <p><b>Values</b> 1 — 255</p> <p><b>timeout</b> <i>timeout</i> — The <b>timeout</b> parameter in seconds, expressed as a decimal integer. This value is used to override the default timeout value and is the amount of time that the router will wait for a message reply after sending the message request. Upon the expiration of message timeout, the requesting router assumes that the message response will not be received. Any response received after the request times out will be silently discarded.</p> <p><b>Default</b> 3</p> <p><b>Values</b> 1 — 60</p> <p><b>fc</b> <i>fc-name</i> — The <b>fc</b> and <b>profile</b> parameters are used to indicate the forwarding class of the MPLS echo request packets. The actual forwarding class encoding is controlled by the network egress LSP-EXP mappings.</p> <p>The LSP-EXP mappings on the receive network interface controls the mapping back to the internal forwarding class used by the far-end router that receives the message request. The egress mappings of the egress network interface on the far-end router controls the forwarding class markings on the return reply message.</p> <p>The LSP-EXP mappings on the receive network interface controls the mapping of the message reply back at the originating router.</p> <p><b>Default</b> be</p> <p><b>Values</b> be, l2, af, l1, h2, ef, h1, nc</p> <p><b>profile</b> <i>profile</i> — The profile state of the MPLS echo request encapsulation.</p>

**Default** out

**Values** in, out

**retry-count** *retry-count* — Specifies the maximum number of consecutive MPLS echo requests, expressed as a decimal integer that do not receive a reply before the trace operation fails for a given TTL.

**Default** 5

**Values** 1 — 255

## ldp-treetrace

**Syntax** [no] ldp-treetrace

**Context** config>test-oam

**Description** This command enables the context to configure LDP treetrace parameters to perform OAM tree trace test operations manually.

The **no** form of the command disables the LDP treetrace parameters.

## fc

**Syntax** **fc** *fc-name* [profile {in | out}]  
**no fc**

**Context** config>test-oam>ldp-treetrace

**Description** This command configures forwarding class name and profile parameters. These parameters indicate the forwarding class of the MPLS echo request packets. The actual forwarding class encoding is controlled by the network egress LSP-EXP mappings.

The LSP-EXP mappings on the receive network interface controls the mapping back to the internal forwarding class used by the far-end 7750 SR7450 ESS7710 SR7210 SAS M that receives the message request. The egress mappings of the egress network interface on the far-end 7750 SR7450 ESS7710 SR7210 SAS M controls the forwarding class markings on the return reply message. The LSP-EXP mappings on the receive network interface controls the mapping of the message reply back at the originating router.

**Default** be

**Parameters** *fc-name* — Specifies the forwarding class of the MPLS echo request packets.

**Values** be, l2, af, l1, h2, ef, h1, nc

profile {in | out} — Specifies the profile value to be used with the forwarding class specified in the *fc-name* parameter.

## path-discovery

<b>Syntax</b>	<b>path-discovery</b>
<b>Context</b>	config>test-oam>ldp-treetrace
<b>Description</b>	This command enables the context to configure path discovery parameters.

## interval

<b>Syntax</b>	<b>interval</b> <i>minutes</i> <b>no interval</b>
<b>Context</b>	config>test-oam>ldp-treetrace>path-discovery
<b>Description</b>	This command configures the time to wait before repeating the LDP tree auto discovery process.
<b>Default</b>	60
<b>Parameters</b>	<i>minutes</i> — Specifies the number of minutes to wait before repeating the LDP tree auto discovery process.
	<b>Values</b> 60 — 1440

## max-path

<b>Syntax</b>	<b>max-path</b> <i>max-paths</i>
<b>Context</b>	config>test-oam>ldp-treetrace>path-discovery
<b>Description</b>	This command configures specifies the maximum number of paths that can be discovered for a selected IP address FEC.
<b>Default</b>	128
<b>Parameters</b>	<i>max-paths</i> — Specifies the tree discovery maximum path.
	<b>Values</b> 1 — 128

## max-ttl

<b>Syntax</b>	<b>max-ttl</b> <i>tvl-value</i>
<b>Context</b>	config>test-oam>ldp-treetrace>path-discovery
<b>Description</b>	This command configures the maximum label time-to-live value for an LSP trace request during the tree discovery.
<b>Default</b>	30

**Parameters** *ttl-value* — Specifies the maximum label time-to-live value for an LSP trace request during the tree discovery.

**Values** 1 — 255

## policy-statement

**Syntax** **policy-statement** *policy-name* [...(up to 5 max)]

**Context** config>test-oam>ldp-treetrace>path-discovery

**Description** This command specifies policies to filter LDP imported address FECs.

**Default** no policy-statement

**Parameters** *policy-name* — Specifies the route policy name to filter LDP imported address FECs. Allowed values are any string up to 32 characters long composed of printable, 7-bit ASCII characters. If the string contains special characters (#, \$, spaces, etc.), the entire string must be enclosed within double quotes. The specified policy name(s) must already be defined.

## retry-count

**Syntax** **retry-count** *retry-count*

**Context** config>oam-test>ldp-treetrace>path-discovery  
config>oam-test>ldp-treetrace>path-probing

**Description** This command configures the path probing maximum number of failures.

**Default** 3

**Parameters** *retry-count* — Specifies the maximum number of consecutive timeouts allowed before failing a path probe (ping).

**Values** 1 — 255

## timeout

**Syntax** **timeout** *timeout*  
**no timeout**

**Context** config>test-oam>ldp-treetrace>path-discovery

**Description** This command is used to override the default timeout value and is the amount of time that the router will wait for a message reply after sending the message request. Upon the expiration of message timeout, the requesting router assumes that the message response will not be received. Any response received after the request times out will be silently discarded.

**Default** 30

**Parameters** *timeout* — Specifies the timeout parameter, in seconds, within a range of 1 to 60, expressed as a decimal integer.

## path-probing

**Syntax** **path-probing**

**Context** config>test-oam>ldp-treetrace

**Description** This command enables the context to configure path probing parameters.

## interval

**Syntax** **interval** *minutes*  
**no interval**

**Context** config>test-oam>ldp-treetrace>path-probing

**Description** This command configures the number of minutes to wait before repeating probing (pinging) a discovered path.

**Default** 1

**Parameters** *minutes* — Specifies the number of minutes to probe all active ECMP paths for each LSP

**Values** 1 — 60

## retry-count

**Syntax** **retry-count** *retry-count*

**Context** config>oam-test>ldp-treetrace>path-discovery  
config>oam-test>ldp-treetrace>path-probing

**Description** This command configures the path probing maximum number of failures.

**Default** 3

**Parameters** *retry-count* — Specifies the maximum number of consecutive timeouts allowed before failing a path probe (ping).

**Values** 1 — 255

## timeout

<b>Syntax</b>	<b>timeout</b> <i>timeout</i> <b>no timeout</b>
<b>Context</b>	config>test-oam>ldp-treetrace>path-probing
<b>Description</b>	This command is used to override the default timeout value and is the amount of time that the router will wait for a message reply after sending the message request. Upon the expiration of message timeout, the requesting router assumes that the message response will not be received. Any response received after the request times out will be silently discarded.
<b>Default</b>	1
<b>Parameters</b>	<i>timeout</i> — Specifies the timeout parameter, in minutes, with a range of 1 to 3 minutes, expressed as a decimal integer.

---

## Show Commands

### saa

**Syntax** `saa [test-name] [owner test-owner]`

**Context** `show>saa`

**Description** Use this command to display information about the SAA test.  
 If no specific test is specified a summary of all configured tests is displayed.  
 If a specific test is specified then detailed test results for that test are displayed for the last three occurrences that this test has been executed, or since the last time the counters have been reset via a system reboot or clear command.

**Parameters** *test-name* — Enter the name of the SAA test for which the information needs to be displayed. The test name must already be configured in the `config>saa>test` context.

This is an optional parameter.

**owner test-owner** — Specifies the owner of an SAA operation up to 32 characters in length.

**Values** 32 characters maximum.

**Default** If a *test-owner* value is not specified, tests created by the CLI have a default owner “TiMOS CLI”.

**Output** **SAA Output** — The following table provides SAA field descriptions.

Label	Description
Test Name	Specifies the name of the test.
Owner Name	Specifies the owner of the test.
Description	Specifies the description for the test type.
Accounting policy	Specifies the associated accounting policy ID.
Administrative status	Specifies whether the administrative status is enabled or disabled.
Test type	Specifies the type of test configured.
Trap generation	Specifies the trap generation for the SAA test.
Test runs since last clear	Specifies the total number of tests performed since the last time the tests were cleared.
Number of failed tests run	Specifies the total number of tests that failed.

Label	Description (Continued)
Last test run	Specifies the last time a test was run.
Threshold type	Indicates the type of threshold event being tested, jitter-event, latency-event, or loss-event, and the direction of the test responses received for a test run: in — inbound out — outbound rt — roundtrip
Direction	Indicates the direction of the event threshold, rising or falling.
Threshold	Displays the configured threshold value.
Value	Displays the measured crossing value that triggered the threshold crossing event.
Last event	Indicates the time that the threshold crossing event occurred.
Run #	Indicates what test run produced the specified values.

### Sample Output

```
*A:bksim130>config>saa>test>trap-gen# show saa mySaaPingTest1
=====
SAA Test Information
=====
Test name           : mySaaPingTest1
Owner name          : TiMOS CLI
Description         : N/A
Accounting policy   : None
Administrative status : Disabled
Test type           : icmp-ping 11.22.33.44
Trap generation     : probe-fail-enable probe-fail-threshold 3
                   : test-fail-enable test-fail-threshold 2
                   : test-completion-enable

Test runs since last clear : 0
Number of failed test runs : 0
Last test result        : Undetermined
-----
Threshold
Type      Direction Threshold Value      Last Event      Run #
-----
Jitter-in Rising      None      None      Never           None
          Falling     None      None      Never           None
Jitter-out Rising      None      None      Never           None
          Falling     None      None      Never           None
Jitter-rt  Rising      None      None      Never           None
          Falling     None      None      Never           None
Latency-in Rising      None      None      Never           None
          Falling     None      None      Never           None
Latency-out Rising      None      None      Never           None
          Falling     None      None      Never           None
```

## OAM and SAA Command Reference

```

Latency-rt  Rising  None    None    Never    None
             Falling None    None    Never    None
Loss-in     Rising  None    None    Never    None
             Falling None    None    Never    None
Loss-out    Rising  None    None    Never    None
             Falling None    None    Never    None
Loss-rt     Rising  None    None    Never    None
             Falling None    None    Never    None
    
```

```

=====
*A:bksim130>config>saa>test>trap-gen#
    
```

```

*A:bksim130>config>saa>test>trap-gen$ show saa mySaaTraceRouteTest1
    
```

```

=====
SAA Test Information
    
```

```

Test name           : mySaaTraceRouteTest1
Owner name          : TiMOS CLI
Description         : N/A
Accounting policy   : None
Administrative status : Disabled
Test type           : icmp-trace 11.22.33.44
Trap generation     : test-fail-enable test-completion-enable
Test runs since last clear : 0
Number of failed test runs : 0
Last test result    : Undetermined
    
```

```

-----
Threshold
    
```

Type	Direction	Threshold	Value	Last Event	Run #
Jitter-in	Rising	None	None	Never	None
	Falling	None	None	Never	None
Jitter-out	Rising	None	None	Never	None
	Falling	None	None	Never	None
Jitter-rt	Rising	None	None	Never	None
	Falling	None	None	Never	None
Latency-in	Rising	None	None	Never	None
	Falling	None	None	Never	None
Latency-out	Rising	None	None	Never	None
	Falling	None	None	Never	None
Latency-rt	Rising	None	None	Never	None
	Falling	None	None	Never	None
Loss-in	Rising	None	None	Never	None
	Falling	None	None	Never	None
Loss-out	Rising	None	None	Never	None
	Falling	None	None	Never	None
Loss-rt	Rising	None	None	Never	None
	Falling	None	None	Never	None

```

=====
*A:bksim130>config>saa>test>trap-gen$
    
```

```

show saa <test-name>
    
```

```

CFM Loopback:
    
```

```

=====
SAA Test Information
    
```

```

Test name           : CFMLoopbackTest
    
```

```

Owner name           : TiMOS CLI
Description          : N/A
Accounting policy    : 1
Continuous           : Yes
Administrative status : Enabled
Test type            : eth-cfm-loopback 00:01:01:01:01:01 mep 1 domain 1
association 1 interval 1 count 10
Trap generation      : None
Test runs since last clear : 1
Number of failed test runs : 0
Last test result     : Success
    
```

```

-----
Threshold
Type           Direction Threshold Value      Last Event      Run #
-----
Jitter-in     Rising      None      None      Never           None
              Falling      None      None      Never           None
Jitter-out    Rising      None      None      Never           None
              Falling      None      None      Never           None
Jitter-rt     Rising      None      None      Never           None
              Falling      None      None      Never           None
Latency-in    Rising      None      None      Never           None
              Falling      None      None      Never           None
Latency-out   Rising      None      None      Never           None
              Falling      None      None      Never           None
Latency-rt    Rising      None      None      Never           None
              Falling      None      None      Never           None
Loss-in       Rising      None      None      Never           None
              Falling      None      None      Never           None
Loss-out      Rising      None      None      Never           None
              Falling      None      None      Never           None
Loss-rt       Rising      None      None      Never           None
              Falling      None      None      Never           None
    
```

```

=====
Test Run: 1
Total number of attempts: 10
Number of requests that failed to be sent out: 0
Number of responses that were received: 10
Number of requests that did not receive any response: 0
Total number of failures: 0, Percentage: 0
    
```

```

(in us)           Min      Max      Average      Jitter
Outbound  :      0.000      0.000      0.000        0
Inbound   :      0.000      0.000      0.000        0
Roundtrip :     10200     10300     10250       100
    
```

```

Per test packet:
Sequence  Result           Delay(us)
1         Response Received 10300
2         Response Received 10300
3         Response Received 10300
4         Response Received 10200
5         Response Received 10300
6         Response Received 10200
7         Response Received 10300
8         Response Received 10200
9         Response Received 10300
10        Response Received 10300
    
```

```

=====
CFM Traceroute:
    
```

## OAM and SAA Command Reference

```

=====
SAA Test Information
=====
Test name                : CFMLinkTraceTest
Owner name               : TiMOS CLI
Description               : N/A
Accounting policy        : None
Continuous               : Yes
Administrative status    : Enabled
Test type                : eth-cfm-linktrace 8A:DB:01:01:00:02 mep 1
domain 1 association 1 interval 1
Trap generation          : None
Test runs since last clear : 1
Number of failed test runs : 0
Last test result         : Success
-----
Threshold
Type      Direction Threshold Value      Last Event      Run #
-----
Jitter-in Rising      None      None      Never          None
          Falling    None      None      Never          None
Jitter-out Rising      None      None      Never          None
          Falling    None      None      Never          None
Jitter-rt  Rising      None      None      Never          None
          Falling    None      None      Never          None
Latency-in Rising      None      None      Never          None
          Falling    None      None      Never          None
Latency-out Rising      None      None      Never          None
          Falling    None      None      Never          None
Latency-rt Rising      None      None      Never          None
          Falling    None      None      Never          None
Loss-in    Rising      None      None      Never          None
          Falling    None      None      Never          None
Loss-out   Rising      None      None      Never          None
          Falling    None      None      Never          None
Loss-rt    Rising      None      None      Never          None
          Falling    None      None      Never          None
-----
Test Run: 1
HopIdx: 1
Total number of attempts: 3
Number of requests that failed to be sent out: 0
Number of responses that were received: 3
Number of requests that did not receive any response: 0
Total number of failures: 0, Percentage: 0
  (in ms)      Min      Max      Average      Jitter
Outbound :      0.000      0.000      0.000      0.000
Inbound  :      0.000      0.000      0.000      0.000
Roundtrip :      2.86      3.67      3.15      0.047
Per test packet:
  Sequence      Outbound      Inbound      RoundTrip      Result
      1          0.000          0.000          3.67      Response Received
      2          0.000          0.000          2.92      Response Received
      3          0.000          0.000          2.86      Response Received

HopIdx: 2
Total number of attempts: 3
Number of requests that failed to be sent out: 0
Number of responses that were received: 3

```

Number of requests that did not receive any response: 0

Total number of failures: 0, Percentage: 0

(in ms)	Min	Max	Average	Jitter
Outbound :	0.000	0.000	0.000	0.000
Inbound :	0.000	0.000	0.000	0.000
Roundtrip :	4.07	4.13	4.10	0.005

Per test packet:

Sequence	Outbound	Inbound	RoundTrip	Result
1	0.000	0.000	4.10	Response Received
2	0.000	0.000	4.13	Response Received
3	0.000	0.000	4.07	Response Received

=====  
CFM Two Way Delay Measurement:  
=====

SAA Test Information  
=====

```

Test name                : CFMTwoWayDelayTest
Owner name               : TiMOS CLI
Description              : N/A
Accounting policy       : None
Continuous              : Yes
Administrative status    : Enabled
Test type                : eth-cfm-two-way-delay 00:01:01:01:01:01 mep 1
domain 1 association 1 interval 1
Trap generation         : None
Test runs since last clear : 1
Number of failed test runs : 0
Last test result        : Success
    
```

-----  
Threshold

Type	Direction	Threshold	Value	Last Event	Run #
Jitter-in	Rising	None	None	Never	None
	Falling	None	None	Never	None
Jitter-out	Rising	None	None	Never	None
	Falling	None	None	Never	None
Jitter-rt	Rising	None	None	Never	None
	Falling	None	None	Never	None
Latency-in	Rising	None	None	Never	None
	Falling	None	None	Never	None
Latency-out	Rising	None	None	Never	None
	Falling	None	None	Never	None
Latency-rt	Rising	None	None	Never	None
	Falling	None	None	Never	None
Loss-in	Rising	None	None	Never	None
	Falling	None	None	Never	None
Loss-out	Rising	None	None	Never	None
	Falling	None	None	Never	None
Loss-rt	Rising	None	None	Never	None
	Falling	None	None	Never	None

...

=====  
Test Run: 1  
HopIdx: 1  
Total number of attempts: 3  
Number of requests that failed to be sent out: 0  
Number of responses that were received: 3  
Number of requests that did not receive any response: 0  
Total number of failures: 0, Percentage: 0

```

Total number of failures: 0, Percentage: 0
(in us)           Min           Max           Average       Jitter
Outbound  :       5095         5095         5095          0
Inbound   :       5095         5095         0.000         0
Roundtrip :      10190        10190        10190         0
Per test packet:
  Sequence  (in us)  Outbound    Inbound     Delay      Delay variation
          1           5195        5195        10190        0
          2           5195        5195        10190        0
          3           5195        5195        10190        0
...
=====

```

## ldp-treetrace

- Syntax**     **ldp-treetrace** [**prefix** *ip-prefix/mask*] [**detail**]
- Context**    show>test-oam
- Description** This command displays OAM LDP treetrace information.
- Parameters** **prefix** *ip-prefix/mask* — Specifies the address prefix and subnet mask of the destination node.  
**detail** — Displays detailed information.

### Sample Output

```

*A:ALA-48# show test-oam ldp-treetrace
Admin State           : Up                Discovery State       : Done
Discovery-intvl (min) : 60                Probe-intvl (min)    : 2
Probe-timeout (min)   : 1                  Probe-retry          : 3
Trace-timeout (sec)   : 60                Trace-retry          : 3
Max-TTL               : 30                Max-path             : 128
Forwarding-class (fc) : be                Profile              : Out
Total Fecs            : 400               Discovered Fecs      : 400
Last Discovery Start   : 12/19/2006 05:10:14
Last Discovery End     : 12/19/2006 05:12:02
Last Discovery Duration : 00h01m48s
Policy1                : policy-1
Policy2                : policy-2

*A:ALA-48# show test-oam ldp-treetrace detail
Admin State           : Up                Discovery State       : Done
Discovery-intvl (min) : 60                Probe-intvl (min)    : 2
Probe-timeout (min)   : 1                  Probe-retry          : 3
Trace-timeout (sec)   : 60                Trace-retry          : 3
Max-TTL               : 30                Max-path             : 128
Forwarding-class (fc) : be                Profile              : Out
Total Fecs            : 400               Discovered Fecs      : 400
Last Discovery Start   : 12/19/2006 05:10:14
Last Discovery End     : 12/19/2006 05:12:02
Last Discovery Duration : 00h01m48s
Policy1                : policy-1
Policy2                : policy-2

```

```

=====
Prefix (FEC) Info
=====
Prefix                Path Last                Probe Discov   Discov
                    Num  Discovered                State State   Status
-----
11.11.11.1/32         54  12/19/2006 05:10:15    OK   Done    OK
11.11.11.2/32         54  12/19/2006 05:10:15    OK   Done    OK
11.11.11.3/32         54  12/19/2006 05:10:15    OK   Done    OK
.....
14.14.14.95/32        72  12/19/2006 05:11:13    OK   Done    OK
14.14.14.96/32        72  12/19/2006 05:11:13    OK   Done    OK
14.14.14.97/32        72  12/19/2006 05:11:15    OK   Done    OK
14.14.14.98/32        72  12/19/2006 05:11:15    OK   Done    OK
14.14.14.99/32        72  12/19/2006 05:11:18    OK   Done    OK
14.14.14.100/32       72  12/19/2006 05:11:20    OK   Done    OK
=====

Legend: uP - unexplored paths, tO - trace request timed out
        mH - max hop exceeded, mP - max path exceeded
        nR - no internal resource

*A:ALA-48# show test-oam ldp-treetrace prefix 12.12.12.10/32
Discovery State : Done                Last Discovered : 12/19/2006 05:11:02
Discovery Status : ' OK '
Discovered Paths : 54                Failed Hops      : 0
Probe State      : OK                Failed Probes    : 0

*A:ALA-48# show test-oam ldp-treetrace prefix 12.12.12.10/32 detail
Discovery State : Done                Last Discovered : 12/19/2006 05:11:02
Discovery Status : ' OK '
Discovered Paths : 54                Failed Hops      : 0
Probe State      : OK                Failed Probes    : 0
=====
Discovered Paths
=====
PathDest              Egr-NextHop          Remote-RtrAddr       Discovery-time
  DiscoveryTtl        ProbeState           ProbeTmOutCnt        RtnCode
-----
127.1.0.5             10.10.1.2           12.12.12.10         12/19/2006 05:11:01
                    7 OK                0                    EgressRtr
127.1.0.9             10.10.1.2           12.12.12.10         12/19/2006 05:11:01
                    7 OK                0                    EgressRtr
127.1.0.15            10.10.1.2           12.12.12.10         12/19/2006 05:11:01
                    7 OK                0                    EgressRtr
127.1.0.19            10.10.1.2           12.12.12.10         12/19/2006 05:11:01
                    7 OK                0                    EgressRtr
127.1.0.24            10.10.1.2           12.12.12.10         12/19/2006 05:11:01
                    7 OK                0                    EgressRtr
127.1.0.28            10.10.1.2           12.12.12.10         12/19/2006 05:11:01
                    7 OK                0                    EgressRtr
.....
127.1.0.252           10.10.1.2           12.12.12.10         12/19/2006 05:11:01
                    7 OK                0                    EgressRtr
127.1.0.255           10.10.1.2           12.12.12.10         12/19/2006 05:11:01
                    7 OK                0                    EgressRtr
=====
*A:ALA-48#

```

## eth-cfm

<b>Syntax</b>	<b>eth-cfm</b>
<b>Context</b>	show
<b>Description</b>	This command enables the context to display CFM information.

## association

<b>Syntax</b>	<b>association</b> [ <i>ma-index</i> ] [ <b>detail</b> ]
<b>Context</b>	show>eth-cfm
<b>Description</b>	This command displays dot1ag association information.
<b>Parameters</b>	<i>ma-index</i> — Specifies the MA index. <b>Values</b> 1— 4294967295 <b>detail</b> — Displays detailed information for the dot1ag association.

### Sample Output

```
*A:node-1# show dot1ag association
=====
Dot1ag CFM Association Table
=====
Md-index   Ma-index   Name                CCM-interval  Bridge-id
-----
1          1          test-ma-1           10            2
1          2          2                   10            20
=====
*A:node-1#

*A:node-1# show dot1ag association 1 detail
-----
Domain 1 Associations:
-----
Md-index           : 1                Ma-index           : 1
Name Format         : charString       CCM-interval       : 10
Name               : test-ma-1
Bridge-id          : 2                MHF Creation       : defMHFnone
PrimaryVlan        : 0                Num Vids           : 0
Remote Mep Id      : 1
Remote Mep Id      : 4
Remote Mep Id      : 5
-----
*A:node-1#
```

## cfm-stack-table

- Syntax** **cfm-stack-table**  
**cfm-stack-table port** [**port** [*port-id* [**vlan** *vlan-id*]]]**sdp** *sdp-id[:vc-id]*[[**level** 0..7]] [**direction** **up** | **down**]  
**cfm-stack-table sdp** [*sdp-id[:vc-id]*] [**level** 0..7][**direction** **up** | **down**]  
**cfm-stack-table virtual** [*service-id*] [**level** 0..7]
- Context** show>eth-cfm
- Description** This command displays stack-table information.
- Parameters** **port** *port-id* — Displays the bridge port or aggregated port on which MEPs or MHFs are configured.  
**vlan** *vlan-id* — Displays the associated VLAN ID.  
**sdp** *sdp-id[:vc-id]* — Displays the SDP binding for the bridge.  
**level** — Display the MD level of the maintenance point.  
**Values** 0 — 7  
**direction** **up** | **down** — Displays the direction in which the MP faces on the bridge port.  
**sdp** [*sdp-id[:vc-id]*] — Displays CFM stack table information for the specified SDP.

**Sample Output**

```
*A:node-1# show dotlag cfm-stack-table
=====
Dotlag CFM SAP Stack Table
=====
Sap           Level Dir  Md-index  Ma-index  Mep-id  Mac-address
-----
1/2/1         4      Up    1         1         5       ac:48:01:02:00:01
1/2/3:100     4      Up    1         1         1       ac:48:01:02:00:03
1/2/3:*       4      Up    1         1         4       ac:48:01:02:00:03
=====
Dotlag CFM SDP Stack Table
=====
Sdp           Level Dir  Md-index  Ma-index  Mep-id  Mac-address
-----
No Matching Entries
=====
*A:node-1#
```

## domain

- Syntax** **domain** [*md-index*] [**association** *ma-index* | **all-associations**] [**detail**]
- Context** show>eth-cfm
- Description** This command displays domain information.
- Parameters** *md-index* — Displays the index of the MD to which the MP is associated, or 0, if none.

**association *ma-index*** — Displays the index to which the MP is associated, or 0, if none.

**all-associations** — Displays all associations to the MD.

**detail** — Displays detailed domain information.

### Sample Output

```
*A:node-1# show dotlag domain
=====
Dotlag CFM Domain Table
=====
Md-index    Level Name                                     Format
-----
1           4      test-1                                         charString
7           4      AA:BB:CC:DD:EE:FF-0                          macAddressAndUint
=====
*A:node-1#

*A:node-1# show dotlag domain 1 detail
=====
Domain 1
Md-index      : 1                      Level           : 4
Permission    : sendIdNone             MHF Creation    : defMHFnone
Name Format    : charString             Next Ma Index   : 3
Name          : test-1
=====
*A:node-1#
```

## mep

**Syntax** **mep** *mep-id* **domain** *md-index* **association** *ma-index* [**loopback**] [**linktrace**]  
**mep** *mep-id* **domain** *md-index* **association** *ma-index* [**remote-mepid** *mep-id* | **all-remote-mepids**]  
**mep** *mep-id* **domain** *md-index* **association** *ma-index* **eth-test-results** [**remote-peer** *mac-address*]  
**mep** *mep-id* **domain** *md-index* **association** *ma-index* **one-way-delay-test** [**remote-peer** *mac-address*]  
**mep** *mep-id* **domain** *md-index* **association** *ma-index* **two-way-delay-test** [**remote-peer** *mac-address*]

**Context** show>eth-cfm

**Description** This command displays Maintenance Endpoint (MEP) information.

**Parameters** **domain** *md-index* — Displays the index of the MD to which the MP is associated, or 0, if none.  
**association** *ma-index* — Displays the index to which the MP is associated, or 0, if none.  
**loopback** — Displays loopback information for the specified MEP.  
**linktrace** — Displays linktrace information for the specified MEP.  
**remote-mepid** — Includes specified remote MEP ID information for the specified MEP.

**one-way-delay-test** — Includes specified MEP information for one-way-test.

**two-way-delay-test** — Includes specified MEP information for two-way-test.

**eth-test-results** — Include eth-test-result information for the specified MEP.

**all-remote-mepids** — Includes all remote mep-id information for the specified MEP.

### Sample Output

```
*A:node-1# show dotlag mep 4 domain 1 association 1 loopback linktrace
-----
Mep Information
-----
Md-index          : 1                Direction       : Up
Ma-index          : 1                Admin           : Enabled
MepId             : 4                CCM-Enable     : Enabled
IfIndex           : 37847040         PrimaryVid     : 4095
FngState          : fngReset
LowestDefectPri   : remErrXcon       HighestDefect   : none
Defect Flags      : None
Mac Address       : ac:48:01:02:00:03 CcmLtmPriority  : 7
CcmTx             : 16863            CcmSequenceErr : 0
CcmLastFailure Frame:
    None
XconCcmFailure Frame:
    None
-----
Mep Loopback Information
-----
LbRxReply         : 0                LbRxBadOrder   : 0
LbRxBadMsdu      : 0                LbTxReply      : 0
LbSequence        : 1                LbNextSequence : 1
LbStatus          : False            LbResultOk     : False
DestIsMepId       : False            DestMepId      : 0
DestMac           : 00:00:00:00:00:00 SendCount       : 0
VlanDropEnable    : True              VlanPriority    : 7
Data TLV:
    None
-----
Mep Linktrace Message Information
-----
LtrxUnexplained   : 0                LtNextSequence  : 1
LtStatus          : False            LtResult        : False
TargIsMepId       : False            TargMepId      : 0
TargMac           : 00:00:00:00:00:00 TTL              : 64
EgressId          : ac:48:01:02:00:03:00:00 SequenceNum     : 1
LtFlags           : None
-----
Mep Linktrace Replies
-----
No entries found
*A:node-1#
```

## mip

<b>Syntax</b>	<b>mip</b>
<b>Context</b>	show>eth-cfm
<b>Description</b>	This command displays SAPs/bindings provisioned for allowing the default MIP creation.

---

## Clear Commands

### saa

<b>Syntax</b>	<b>saa-test</b> [ <i>test-name</i> [ <b>owner</b> <i>test-owner</i> ]]
<b>Context</b>	clear
<b>Description</b>	Clear the SAA results for the latest and the history for this test. If the test name is omitted, all the results for all tests are cleared.
<b>Parameters</b>	<i>test-name</i> — Name of the SAA test. The test name must already be configured in the <b>config&gt;saa&gt;test</b> context. <b>owner</b> <i>test-owner</i> — Specifies the owner of an SAA operation up to 32 characters in length. <b>Default</b> If a <i>test-owner</i> value is not specified, tests created by the CLI have a default owner “TIMOS CLI”.

## Debug Commands

### lsp-ping-trace

<b>Syntax</b>	<b>lsp-ping-trace</b> [tx   rx   both] [raw   detail] <b>no lsp-ping-trace</b>
<b>Context</b>	debug>oam
<b>Description</b>	This command enables debugging for lsp-ping.
<b>Parameters</b>	<b>tx   rx   both</b> — Specifies to enable LSP ping debugging for TX, RX, or both RX and TX for the for debug direction. <b>raw   detail</b> — Displays output for the for debug mode.

---

## Tools Command Reference

---

### Command Hierarchies

- [Tools Dump Commands on page 281](#)
- [Tools Perform Commands on page 283](#)

### Configuration Commands

#### Tools Dump Commands

```

tools
  — dump
    — aps aps-id [clear]
    — aps mc-aps-signaling [clear]
    — aps mc-aps-ppp [clear]
    — lag lag-id lag-id
    — ldp-treetrace {prefix ip-prefix/mask | manual-prefix ip-prefix/mask} [path-destination ip-address] [trace-tree]
    — persistence
      — submgt [record record-key]
      — summary
    — ppp port-id
    — redundancy
      — multi-chassis
        — mc-endpoint peer ip-address
        — mc-ring
        — mc-ring peer ip-address [ring sync-tag]
        — srrp-sync-database [instance instance-id] [peer ip-address]
        — sync-database [peer ip-address] [port port-id | lag-id] [sync-tag sync-tag] [application application] [detail] [type type]
    — router router-instance
      — dhcp
        — group-if-mapping [clear]
        — group-if-stats [clear]
      — ldp
        — fec prefix ip-prefix/mask
        — fec vc-type {ethernet|vlan} vc-id vc-id
        — instance
        — interface [ip-int-name | ip-address]
        — memory-usage
        — peer ip-address
        — session [ip-addr[:label-space]] [connection|peer|adjacency]
        — sockets
        — timers
      — mpls
        — ftn [endpoint endpoint | sender sender | nexthop nexthop | lsp-id lsp-id | tunnel-id tunnel-id | label start-label end-label]
  
```

- **ilm** [endpoint *endpoint* | sender *sender* | nexthop *nexthop* | lsp-id *lsp-id* | tunnel-id *tunnel-id* | label *start-label end-label*]
- **lspinfo** [*lsp-name*] [detail]
- **memory-usage**
- **te-lspinfo** [endpoint *ip-address*] [sender *ip-address*] [lspid *lsp-id*] [detail] [p2p | p2p-tid *tunnel-id*]
- **te-lspinfo** [endpoint *ip-address*] [sender *ip-address*] [lspid *lsp-id*] [detail] [p2p | p2p-tid *tunnel-id*] { [phops] [nhops] [s2l *ip-address*] }
- **ospf**
- **ospf3**
  - **abr** [detail]
  - **asbr** [detail]
  - **bad-packet** *interface-name*
  - **leaked-routes** [summary | detail]
  - **memory-usage** [detail]
  - **request-list** [neighbor *ip-address*] [detail]
  - **request-list virtual-neighbor** *ip-address area-id area-id* [detail]
  - **retransmission-list** [neighbor *ip-address*] [detail]
  - **retransmission-list virtual-neighbor** *ip-address area-id area-id* [detail]
  - **route-summary**
  - **route-table** [type] [detail]
- **pim**
  - **iom-failures** [detail]
- **rsvp**
  - **psb** [endpoint *endpoint-address*] [sender *sender-address*] [tunnelid *tunnel-id*] [lspid *lsp-id*]
  - **rsb** [endpoint *endpoint-address*] [sender *sender-address*] [tunnelid *tunnel-id*] [lspid *lsp-id*]
  - **tcsb** [endpoint *endpoint-address*] [sender *sender-address*] [tunnelid *tunnel-id*] [lspid *lsp-id*]
- **static-route** *ldp-sync-status*
- **web-rd**
  - **http-client** [*ip-prefix/mask*]
- **service**
  - **base-stats** [clear]
  - **iom-stats** [clear]
  - **l2pt-diags**
  - **l2pt-diags** clear
  - **l2pt-diags** detail
  - **mc-endpoint** *mc-ep-id*
  - **radius-discovery** [*svc-id service-id*]
  - **vpls-fdb-stats** [clear]
  - **vpls-mfib-stats** [clear]
- **system-resources** *slot-number*

## Tools Perform Commands

```

tools
  — perform
    — aps
      — clear aps-id {protect | working}
      — exercise aps-id {protect | working}
      — force aps-id {protect | working}
      — lockout aps-id
      — request aps-id {protect | working}
    — cron
      — action
        — stop [action-name] [owner action-owner] [all]
      — tod
        — re-evaluate
          — customer customer-id [site customer-site-name]
          — filter filter-type [filter-id]
          — service id service-id [sap sap-id]
          — tod-suite tod-suite-name
    — lag
      — clear-force all-mc
      — clear-force lag-id lag-id [sub-group sub-group-id]
      — clear-force peer-mc ip-address
      — force all-mc {active | standby}
      — force lag-id lag-id [sub-group sub-group-id] {active | standby}
      — force peer-mc peer-ip-address {active | standby}
    — log
      — test-event
    — router [router-instance]
      — consistency
      — isis
        — ldp-sync-exit
        — run-manual-spf
    — mpls
      — cspf to ip-addr [from ip-addr] [bandwidth bandwidth] [include-bitmap
        bitmap] [exclude-bitmap bitmap] [hop-limit limit] [exclude-address
        excl-addr [excl-addr...(up to 8 max)]] [use-te-metric] [strict-srlg] [srlg-
        group grp-id...(up to 8 max)]] [exclude-node excl-node-id [excl-node-id
        ..(up to 8 max)]] [skip-interface interface-name] [ds-class-type class-
        type] [cspf-reqtype req-type] [least-fill-min-thd thd] [setup-priority val]
        [hold-priority val]
      — resignal lsp lsp-name path path-name delay minutes
      — resignal {p2mp-lsp p2mp-lsp-name p2mp-instance p2mp-instance-name
        | p2mp-delay p2mp-minutes}
      — trap-suppress number-of-traps time-interval
    — ospf [ospf-instance]
      — ldp-sync-exit
      — refresh-lsas [lsa-type] [area-id]
      — run-manual-spf externals-only
    — ospf3 [ospf-instance]
      — refresh-lsas [lsa-type] [area-id]
      — run-manual-spf externals-only

```

- **security**
    - **authentication-server-check** *server-address ip-address* [**port** *port*] **user-name** *DHCP client user name* **password** *password* **secret** *key* [**source-address** *ip-address*] [**timeout** *seconds*] [**router** *router-instance*]
  - **service**
    - **egress-multicast-group** *group-name*
      - **force-optimize**
    - **eval-pw-template** *policy-id* [**allow-service-impact**]
    - **id** *service-id*
      - **endpoint** *endpoint-name*
        - **force-switchover** *sdp-id:vc-id*
        - **no force-switchover**
      - **eval-pw-template** *policy-id* [**allow-service-impact**]
      - **mcaac sap** *sap-id* **recalc policy** *policy-name* [**bundle** *bundle-name*]
      - **mcaac sdp** *sdp-id:vc-id* **recalc policy** *policy-name* [**bundle** *bundle-name*]
- tools**
- **perform**
    - **subscriber-mgmt**
      - **edit-lease-state** **sap** *sap-id* **ip** *ip-address* [**subscriber** *sub-ident-string*] [**sub-profile-string** *sub-profile-string*] [**sla-profile-string** *sla-profile-string*]
      - **edit-lease-state** **svc-id** *service-id* **ip** *ip-address* [**subscriber** *sub-ident-string*] [**sub-profile-string** *sub-profile-string*] [**sla-profile-string** *sla-profile-string*]
      - **eval-lease-state** [**svc-id** *service-id*] [**sap** *sap-id*] [**subscriber** *sub-ident-string*] [**ip** *ip-address*]
      - **forcerenew** **svc-id** *service-id* {**ip** *ip-address[/mask]>*|**mac** *ieee-address*}
      - **forcerenew** {**interface** *interface-name* | **sap** *sap-id*|**sdp** *sdp-id:vc-id*} [**ip** *ip-address[/mask]* | **mac** *ieee-address*]
      - **re-ident-sub** *old-sub-ident-string* **to** *new-sub-ident-string*
      - **remap-lease-state** **old-mac** *ieee-address* **mac** *ieee-address*
      - **remap-lease-state** **sap** *sap-id* [**mac** *ieee-address*]

---

## Tools Configuration Commands

---

### Generic Commands

#### tools

<b>Syntax</b>	<b>tools</b>
<b>Context</b>	root
<b>Description</b>	This command enables the context to enable useful tools for debugging purposes.
<b>Default</b>	none
<b>Parameters</b>	<b>dump</b> — Enables dump tools for the various protocols. <b>perform</b> — Enables tools to perform specific tasks.

---

## Dump Commands

### dump

<b>Syntax</b>	<b>dump</b> <i>router-name</i>
<b>Context</b>	tools
<b>Description</b>	The context to display information for debugging purposes.
<b>Default</b>	none
<b>Parameters</b>	<i>router-name</i> — Specify a router name, up to 32 characters in length.
	<b>Default</b> Base

### aps

<b>Syntax</b>	<b>aps</b> <i>aps-id</i> [ <b>clear</b> ] <b>aps mc-aps-signaling</b> [ <b>clear</b> ] <b>aps mc-aps-ppp</b> [ <b>clear</b> ]
<b>Context</b>	tools>dump>aps
<b>Description</b>	This command displays Automated Protection Switching (APS) information.
<b>Parameters</b>	<b>clear</b> — Removes all Automated Protection Switching (APS) operational commands. <b>mc-aps-signaling</b> — Displays multi-chassis APS signaling information. <b>mc-aps-ppp</b> — Displays multi-chassis APS PPP information.

#### Sample Output

```
*A:AS_SR7_2# tools dump aps aps-33

GrpId = 33, state = Running, mode:cfg/oper = Bi-directional/Bi-directional
  revert = 0, workPort: N/A, protPort: 2/1/1, activePort: working
  rxK1 = 0x0 (No-Req on Protect), physRxK1 = 0x0, rxK2 = 0x5
  txK1 = 0x0 (No-Req on Protect), physTxK1 = 0x0, txK2 = 0x5
  K1ReqToBeTxed = 0x0, K1ChanToBeTxed = 0x0, lastRxReq = 0xc
  MC-APS Nbr = 100.100.100.1 (Up), advIntvl = 10, hold = 30
  workPort: status = OK, Tx-Lais = None, sdCnt = 1, sfCnt = 1
    numSwitched = 1, switchSecs = 0, lastSwitched = 07/25/2007 08:00:12
    disCntTime = , alarms = , switchCmd = No Cmd
  protPort: status = OK, Tx-Lais = None, sdCnt = 1, sfCnt = 0
    numSwitched = 1, switchSecs = 0, lastSwitched = 07/25/2007 08:03:39
    disCntTime = , alarms = , switchCmd = No Cmd
  GrpStatus: OK, mmCnt = 1, cmCnt = 1, psbfCnt = 1, feplfCnt = 2
  LocalSwitchCmd: priority = No-Req, portNum = 0
  RemoteSwitchCmd: priority = No-Req, portNum = 0
  Running Timers = mcAdvIntvl mcHold
```

```

processFlag =  apsFailures = , sonet = Y
DebugInfo: dmEv = 0, dmClrEv = 0, amEv = 1, amClrEv = 1
           cmEv = 1, cmClrEv = 1, psbfEv = 1, psbfClrEv = 1
           feplfEv = 2, feplfClrEv = 2, wtrEv = 0, psbfDetectEv = 0
           wSdEv = 1, wSfEv = 2, pSdEv = 1, pSfEv = 1
           portStatusEv = 8, rxK1Ev = 9, txLaisEv = 2, lastEvName = FeplClr
           CtlUpEv = 3, CtlDnEv = 2, wAct = 0, wDeAct = 0
Seq      Event TxK1/K2 RxK1/K2 Dir   Active   Time
====
000      ProtAdd 0xc005 0x0000 Tx-->   Work    497 02:18:10.590
001      RxKByte 0xc005 0x6dea Rx<--   Work    497 02:20:14.820
002      RxKByte 0xc005 0xc005 Rx<--   Work    497 02:21:30.970
003      RxKByte 0xc005 0x2005 Rx<--   Work    497 02:21:36.530
004      pSFClr  0x0005 0x2005 Tx-->   Work    497 02:21:40.590
005      RxKByte 0x0005 0x0005 Rx<--   Work    497 02:21:40.600
006      RxKByte 0x0005 0xc115 Rx<--   Work    497 02:25:22.840
007      RxKByte 0x2115 0xc115 Tx-->   Prot    497 02:25:22.840
008      RxKByte 0x2115 0xa115 Rx<--   Prot    000 00:00:47.070
009      RxKByte 0x2115 0x1115 Rx<--   Prot    000 00:00:47.560
010      RxKByte 0x2115 0xc005 Rx<--   Prot    000 00:00:57.010
011      RxKByte 0x2005 0xc005 Tx-->   Work    000 00:00:57.010
012      RxKByte 0x2005 0x0005 Rx<--   Work    000 00:01:06.170
013      RxKByte 0x0005 0x0005 Tx-->   Work    000 00:01:06.170

```

## Sample Output

```

:AS_SR7_1# tools dump aps mc-aps-ppp

pppmMcsModStarted = Yes
pppmMcsDbgDoSync = Yes
pppmMcsApsGrpHaAuditDone = Yes
pppmMcsPostHaSyncedApsGrpId = 47
pppmMcsMcApsChanCnt = 1280

pppmMcsDbgRxPktCnt = 2560
pppmMcsDbgRxPktNotProcessedCnt = 0
pppmMcsDbgRxPktInvalidCnt = 0
pppmMcsDbgInconsistentRxPktDropCnt = 0
pppmMcsDbgInconsistentTxPktDropCnt = 1176
pppmMcsDbgTxPktNotSentCnt = 0
pppmMcsDbgTxPktSentCnt = 25
pppmMcsDbgEvtDropCnt = 0
pppmMcsDbgMemAllocErrCnt = 0
pppmMcsDbgReTxCnt = 0
pppmMcsDbgReTxExpCnt = 0
pppmMcsDbgReReqCnt = 0

pppmMcsStateAckQueueCnt (curr/peek) = 0/130
pppmMcsStateReqQueueCnt (curr/peek) = 0/1280
pppmMcsStateReReqQueueCnt (curr/peek) = 0/256
pppmMcsStateTxQueueCnt (curr/peek) = 0/512
pppmMcsStateReTxQueueCnt (curr/peek) = 0/130

MC-APS Peer Info :
-----

Grp 13 Addr 100.100.100.2 - Up

```

## Dump Commands

```
Grp 20 Addr 100.100.100.2 - Up
Grp 35 Addr 100.100.100.2 - Up
Grp 43 Addr 100.100.100.2 - Up
Grp 47 Addr 100.100.100.2 - Up
```

```
Number of pppmMcs Evt Msgs dispatched:
ctl_link_state : 0
ctl_link_up_tmr : 0
ctl_link_down_tmr : 0
ha_audit_done : 0
```

## Sample Output

```
*A:eth_aps_sr7# tools dump aps mc-aps-signaling
```

```
MC-APS Control Debug Counters :
```

```
-----
Ctl Pkt Rx = 0
Invalid Rx Ctl Pkt = 0
Incompatible Rx Ctl Pkt = 0
Nbr not Rx Ctl Pkt = 0
Invalid Rx Ctl Pkt Tlv = 0
Ctl Pkt Rx-ed before HaReady = 0
Not sent Tx Ctl Pkt = 0
```

```
MC-APS-LAG Debug Counters :
```

```
-----
Ctl Pkt Rx from IOM          = 0

Not processed Rx Ctl Pkt    = 0
Invalid Rx Ctl Pkt          = 0
Incompatible Rx Ctl Pkt    = 0
Rx Ctl Pkt queueing failed = 0

Ctl Pkt Tx (direct)         = 0
Ctl Pkt Tx (UDP socket)    = 0
Not sent Tx Ctl Pkt        = 0

Route Update                = 0
Matched Route Update        = 0

Msg Buf Alloc Failed        = 0
```

```
MC-APS-LAG NbrRoute Entries :
```

```
-----
NbrAddr 1.1.1.1 NextHopAddr ::
  EgressIfIndex = 0
  EgressPortId = Unknown
  app refCnt = 1
  refCntTotal = 1
```

## lag

<b>Syntax</b>	<b>lag lag-id</b> <i>lag-id</i>
<b>Context</b>	tools>dump
<b>Description</b>	This tool displays LAG information.
<b>Parameters</b>	<i>lag-id</i> — Specify an existing LAG id.
<b>Values</b>	1 — 200 (7750 SR-1: 1 — 64)

```
ALA-12>tools>dump# lag lag-id 1
Port state      : Ghost
Selected subgrp : 1
NumActivePorts  : 0
ThresholdRising : 0
ThresholdFalling: 0
IOM bitmask     : 0
Config MTU      : 1514
Oper. MTU       : 1514
Bandwidth       : 100000
ALA-12>tools>dump#
```

## ldp-treetrace

<b>Syntax</b>	<b>ldp-treetrace</b> { <b>prefix</b> <i>ip-prefix/mask</i>   <b>manual-prefix</b> <i>ip-prefix/mask</i> }[ <b>path-destination</b> <i>ip-address</i> ] [ <b>trace-tree</b> ]
<b>Context</b>	tools>dump
<b>Description</b>	This command displays TreeTrace information.
<b>Parameters</b>	<b>prefix</b> <i>ip-prefix/mask</i> — Specifies the IP prefix and host bits.
<b>Values</b>	host bits: must be 0 mask: 0 — 32

## persistence

<b>Syntax</b>	persistence
<b>Context</b>	tools>dump
<b>Description</b>	This command enables the context to display persistence information for debugging purposes.

## Dump Commands

### submgt

- Syntax** `submgt [record record-key]`
- Context** `tools>dump>persistence`
- Description** This command displays subscriber management persistence information.

### summary

- Syntax** `summary`
- Context** `tools>dump>persistence`
- Description** The context to display persistence summary information for debugging purposes.

#### Sample Output

```
A:ALA-B# tools dump persistence summary
=====
Persistence Summary on Slot A
=====
Client           Location           Entries in use    Status
-----
xxxxxx          cf1:\l2_dhcp.pst   200              ACTIVE
-----
Persistence Summary on Slot B
=====
Client           Location           Entries in use    Status
-----
xxxxxx          cf1:\l2_dhcp.pst   200              ACTIVE
-----
A:ALA-B#
```

### redundancy

- Syntax** `redundancy`
- Context** `tools>dump`
- Description** This command enables the context to dump tools for redundancy.

### multi-chassis

- Syntax** `multi-chassis`
- Context** `tools>dump>redundancy>multi-chassis`
- Description** This command enables the context to dump tools for multi-chassis redundancy.

## mc-endpoint

<b>Syntax</b>	<b>mc-endpoint peer</b> <i>ip-address</i>
<b>Context</b>	tools>dump>redundancy>multi-chassis
<b>Description</b>	This command dumps multi-chassis endpoint information.
<b>Parameters</b>	<b>peer</b> <i>ip-address</i> — Specifies the peer's IP address.

## mc-ring

<b>Syntax</b>	<b>mc-ring</b> <b>mc-ring peer</b> <i>ip-address</i> [ <b>ring</b> <i>sync-tag</i> ]
<b>Context</b>	tools>dump>redundancy>multi-chassis
<b>Description</b>	This command dumps multi-chassis ring information. <b>peer</b> <i>ip-address</i> — Specifies the peer's IP address. <b>ring</b> <i>sync-tag</i> — Specifies the ring's sync-tag created in the <b>config&gt;redundancy&gt;mc&gt;peer&gt;mcr&gt;ring</b> context.

## srrp-sync-database

<b>Syntax</b>	<b>srrp-sync-database</b> [ <b>instance</b> <i>instance-id</i> ] [ <b>peer</b> <i>ip-address</i> ]
<b>Context</b>	tools>dump>redundancy>multi-chassis
<b>Description</b>	This command dumps SRRP database information. <b>peer</b> <i>ip-address</i> — Specifies the peer's IP address. <b>instance</b> <i>instance-id</i> — Dumps information for the specified Subscriber Router Redundancy Protocol instance configured on this system. <b>Values</b> 1 — 4294967295

## sync-database

<b>Syntax</b>	<b>sync-database</b> [ <b>peer</b> <i>ip-address</i> ] [ <b>port</b> <i>port-id</i>   <i>lag-id</i> ] [ <b>sync-tag</b> <i>sync-tag</i> ] [ <b>application</b> <i>application</i> ] [ <b>detail</b> ] [ <b>type</b> <i>type</i> ]
<b>Context</b>	tools>dump>redundancy>multi-chassis
<b>Description</b>	This command dumps MCS database information. <b>peer</b> <i>ip-address</i> — Specifies the peer's IP address.

## Dump Commands

**port** *port-id* | *lag-id* — Indicates the port or LAG ID to be synchronized with the multi-chassis peer.

**Values** *slot/mda/port* or *lag-lag-id*

**sync-tag** *sync-tag* — Specifies a synchronization tag to be used while synchronizing this port with the multi-chassis peer.

**application** *application* — Specifies a particular multi-chassis peer synchronization protocol application.

**Values**

dhcp-server:	local dhcp server
igmp:	Internet group management protocol
igmp-snooping:	igmp-snooping
mc-ring:	multi-chassis ring
mld-snooping:	multicast listener discovery-snooping
srrp:	simple router redundancy protocol
sub-host-trk:	subscriber host tracking
sub-mgmt:	subscriber management

**type** *type* — Indicates the locally deleted or alarmed deleted entries in the MCS database per multi-chassis peer.

**Values** alarm-deleted, local-deleted

**detail** — Displays detailed information.

## ppp

**Syntax** **ppp** *port-id*

**Context** tools>dump

**Description** This command displays PPP information for a port.

**Default** none

**Parameters** *port-id* — Specify the port ID.

**Values**

<i>port-id</i>	<i>slot/mda/port[.channel]</i>
bundle-id:	<i>bundle-type-slot/mda.bundle-num</i>
	bundle: keyword
	type: ppp
	bundle-num: 1 — 256
bpgrp-id:	<i>bpgrp-type-bpgrp-num</i>
	bpgrp: keyword
	type: ppp
	bpgrp-num: 1 — 1280
aps-id:	<i>aps-group-id[.channel]</i>
	aps: keyword
	group-id: 1 — 64

### Sample Output

```
*A:sr7# tools dump ppp aps-1.1.1.1
```

```

=====
Id          : aps-1.1.1.1      ppp unit   : 40
member of   : bpgrp-ppp-1
=====
looped back : no              dbgMask    : 0x0
-----
LCP
-----
phase       : NETWORK        state       : OPENED
passive     : off            silent      : off
restart     : on

mru         : 1500           mtu         : 1502
ack'd peer mru : 1500
got local mrru : 1524
local magic  : 0x0           peer magic  : 0x0

keepalive   : on             echo num    : 2
echo timer  : on             echos fail  : 3
echo intv   : 10            echos pend  : 0

options     mru      asyncMap upap   chap   magic   pfc
we negotiate Yes    No      No      No     No     Yes
peer ack'd  Yes    No      No      No     No     No
we allow    Yes    No      No      No     No     Yes
we ack'd    Yes    No      No      No     No     No

options     acfc     lqr      mrru    shortSeq endPoint mlhdrfmt
we negotiate Yes    No      Yes     No      Yes     No
peer ack'd  No     No      Yes     No      Yes     No
we allow    Yes    No      Yes     Yes     Yes     No
we ack'd    No     No      Yes     No      Yes     No
...
=====
*A:sr7#

```

## system-resources

- Syntax** `system-resources slot-number`
- Context** `tools>dump`
- Description** This command displays system resource information.
- Default** none
- Parameters** *slot-number* — Specify a specific slot to view system resources information.

## Service Commands

### service

<b>Syntax</b>	<b>service</b>
<b>Context</b>	tools>dump
<b>Description</b>	Use this command to configure tools to display service dump information.

### base-stats

<b>Syntax</b>	<b>base-stats [clear]</b>
<b>Context</b>	tools>dump>service
<b>Description</b>	Use this command to display internal service statistics.
<b>Default</b>	none
<b>Parameters</b>	<b>clear</b> — Clears stats after reading.

### iom-stats

<b>Syntax</b>	<b>iom-stats [clear]</b>
<b>Context</b>	tools>dump>service
<b>Description</b>	Use this command to display IOM message statistics.
<b>Default</b>	none
<b>Parameters</b>	<b>clear</b> — Clears stats after reading.

### l2pt-diags

<b>Syntax</b>	<b>l2pt-diags</b> <b>l2pt-diags clear</b> <b>l2pt-diags detail</b>
<b>Context</b>	tools>dump>service
<b>Description</b>	Use this command to display L2pt diagnostics.
<b>Default</b>	none
<b>Parameters</b>	<b>clear</b> — Clears the diags after reading.

**detail** — Displays detailed information.

### Sample Output

```
A:ALA-48>tools>dump>service# l2pt-diags
[ l2pt/bpdu error diagnostics ]
  Error Name      | Occurrence   | Event log
-----+-----+-----
[ l2pt/bpdu forwarding diagnostics ]

  Rx Frames   | Tx Frames   | Frame Type
-----+-----+-----
A:ALA-48>tools>dump>service#

A:ALA-48>tools>dump>service# l2pt-diags detail
[ l2pt/bpdu error diagnostics ]
  Error Name      | Occurrence   | Event log
-----+-----+-----
[ l2pt/bpdu forwarding diagnostics ]

  Rx Frames   | Tx Frames   | Frame Type
-----+-----+-----
[ l2pt/bpdu config diagnostics ]
WARNING - service 700 has l2pt termination enabled on all access points :
         consider translating further down the chain or turning it off.
WARNING - service 800 has l2pt termination enabled on all access points :
         consider translating further down the chain or turning it off.
WARNING - service 9000 has l2pt termination enabled on all access points :
         consider translating further down the chain or turning it off.
WARNING - service 32806 has l2pt termination enabled on all access points :
         consider translating further down the chain or turning it off.
WARNING - service 90001 has l2pt termination enabled on all access points :
         consider translating further down the chain or turning it off.
A:ALA-48>tools>dump>service#
```

## mc-endpoint

**Syntax** **mc-endpoint** *mc-ep-id*

**Context** tools>dump>service

**Description** Use this command to display multi-chassis endpoint information.

**Parameters** *mc-ep-id* — Specifies a multi-chassis endpoint ID.

**Values** 1 — 4294967295

### Sample Output

```
*A:Dut-B# tools dump service mc-endpoint 1
MC Endpoint Info
  mc-endpoint id           : 1
  endpoint                 : mcep-t1
  service                  : 1
  peer ref type            : peer-name
  peer                     : Dut-C
```

## Service Commands

```
mc sel logic           : peer selected active
selection master      : No
retransmit pending    : No
initial config sync   : Yes
config sync           : Yes
peer not mcep         : No
peer acked non-mcep   : No
config mismatch       : No
initial state rx      : Yes
initial state sync    : Yes
state sync            : Yes
can aggregate         : Yes
sel peer active       : No
peer sel active       : Yes
passive mode active   : No
own eligible force    : No
own eligible double active : Yes
own eligible pw status bits : 0
own eligible precedence : 2
own eligible conf chg : No
own eligible revert wait : No
peer eligible force    : No
peer eligible double active : Yes
peer eligible pw status bits : 0
peer eligible precedence : 3
peer eligible conf chg : No
peer eligible revert wait : No
*A:Dut-B# tools perform service id 1 endpoint mcep-t1 force-switchover 221:1
*A:Dut-B>show#
*A:Dut-B# show service id 1 endpoint
=====
Service 1 endpoints
=====
Endpoint name           : mcep-t1
Description              : (Not Specified)
Revert time              : 0
Act Hold Delay           : 0
Ignore Standby Signaling : false
Suppress Standby Signaling : false
Block On Mesh Fail       : true
Multi-Chassis Endpoint   : 1
MC Endpoint Peer Addr    : 3.1.1.3
Psv Mode Active          : No
Tx Active                : 221:1 (forced)
Tx Active Up Time        : 0d 00:00:17
Revert Time Count Down   : N/A
Tx Active Change Count   : 6
Last Tx Active Change    : 02/14/2009 00:17:32
-----
Members
-----
Spoke-sdp: 221:1 Prec:1                               Oper Status: Up
Spoke-sdp: 231:1 Prec:2                               Oper Status: Up
=====
*A:Dut-B#
```

## radius-discovery

- Syntax** `radius-discovery [svc-id service-id]`
- Context** `tools>dump>service`
- Description** Use this command to display RADIUS Discovery membership information.

**Sample Output**

```
A:ALA-48# tools dump service radius-discovery
-----
Service Id 103 Vpn Id 103 UserName 901:103 (Vpn-Id) PolicyName RAD_Disc for Ser-
vice 103
Waiting for Session Timeout (Polling 60), Seconds in State 17
-----
      SdpId      Vcid Deliver      Ip Addr      VcType      Mode      Split Horizon
-----
          3         103   LDP    10. 20.  1.  3      Ether      Spoke
          4         103   LDP    10. 20.  1.  2      Ether      Spoke
-----
A:ALA-48#
```

## vpls-fdb-stats

- Syntax** `vpls-fdb [clear]`
- Context** `tools>dump>service`
- Description** Use this command to display VPLS FDB statistics.
- Default** none
- Parameters** `clear` — Clears stats after reading.

## vpls-mfib-stats

- Syntax** `vpls-mfib-stats [clear]`
- Context** `tools>dump>service`
- Description** Use this command to display VPLS MFIB statistics.
- Default** none
- Parameters** `clear` — Clears stats after reading.

---

## Router Commands

### router

<b>Syntax</b>	<b>router</b> <i>router-instance</i>
<b>Context</b>	tools>dump tools>perform
<b>Description</b>	This command enables tools for the router instance.
<b>Default</b>	none
<b>Parameters</b>	<b>router</b> <i>router-instance</i> — Specifies the router name or service ID.  <b>Values</b> <i>router-name:</i> Base , management <i>service-id:</i> 1 — 2147483647  <b>Default</b> Base

### dhcp

<b>Syntax</b>	<b>dhcp</b>
<b>Context</b>	tools>dump>router
<b>Description</b>	This command enables the context to configure dump router tools for DHCP.

### group-if-mapping

<b>Syntax</b>	<b>group-if-mapping</b> [clear]
<b>Context</b>	tools>dump>router>dhcp
<b>Description</b>	This command dumps group interface mapping information stored in by the DHCP cache for the Routed CO model of operation.

### group-if-stats

<b>Syntax</b>	<b>group-if-stats</b> [clear]
<b>Context</b>	tools>dump>router>dhcp
<b>Description</b>	This command dumps group interface statistics information about the DHCP cache for the Routed CO model of operation.

## lag

<b>Syntax</b>	<b>lag</b>
<b>Context</b>	tools>perform
<b>Description</b>	This command configures tools to control LAG.

## clear-force

<b>Syntax</b>	<b>clear-force all-mc</b> <b>clear-force peer-mc</b> <i>ip-address</i> <b>clear-force lag-id</b> <i>lag-id</i> [ <b>sub-group</b> <i>sub-group-id</i> ]
<b>Context</b>	tools>perform>lag
<b>Description</b>	This command clears a forced status.
<b>Parameters</b>	<b>all-mc</b> — Clears all multi-chassis LAG information. <b>lag-id</b> <i>lag-id</i> — Specify an existing LAG id. <b>Values</b> 1 — 200 (7750 SR-1: 1 — 64)

## force

<b>Syntax</b>	<b>force all-mc</b> { <b>active</b>   <b>standby</b> } <b>force peer-mc</b> <i>peer-ip-address</i> { <b>active</b>   <b>standby</b> } <b>force lag-id</b> <i>lag-id</i> [ <b>sub-group</b> <i>sub-group-id</i> ] { <b>active</b>   <b>standby</b> }
<b>Context</b>	tools>perform>lag
<b>Description</b>	This command forces an active or standby status.
<b>Parameters</b>	<b>all-mc</b> — Clears all multi-chassis LAG information. <b>active</b> — If <b>active</b> is selected, then all drives on the active CPM are forced. <b>standby</b> — If <b>standby</b> is selected, then all drives on the standby CPM are forced. <b>all-mc</b> — Clears all multi-chassis LAG information. <b>lag-id</b> <i>lag-id</i> — Specify an existing LAG id. <b>Values</b> 1 — 200 (7750 SR-1: 1 — 64)

## Router Commands

### log

<b>Syntax</b>	<b>log</b>
<b>Context</b>	tools>perform
<b>Description</b>	Tools for event logging.

### test-event

<b>Syntax</b>	<b>test-event</b>
<b>Context</b>	tools>perform>log
<b>Description</b>	Generates a test event.

### ldp

<b>Syntax</b>	<b>ldp</b>
<b>Context</b>	tools>dump>router
<b>Description</b>	This command enables dump tools for LDP.
<b>Default</b>	none

### interface

<b>Syntax</b>	<b>interface</b> [ <i>ip-int-name</i>   <i>ip-address</i> ]
<b>Context</b>	tools>dump>router>ldp
<b>Description</b>	This command displays information for an LDP interface.
<b>Default</b>	none
<b>Parameters</b>	<i>ip-int-name</i> — Specifies the interface name. <i>ip-address</i> — Specifies the IP address.

### peer

<b>Syntax</b>	<b>peer</b> <i>ip-address</i>
<b>Context</b>	tools>dump>router>ldp
<b>Description</b>	This command displays information for an LDP peer.
<b>Default</b>	none

**Parameters** *ip-address* — Specifies the IP address.

## fec

**Syntax** **fec prefix** [*ip-prefix/mask*]  
**fec vc-type** {**ethernet** | **vlan**} **vc-id** *vc-id*

**Context** tools>dump>router>ldp

**Description** This command displays information for an LDP FEC.

**Default** none

**Parameters** *ip-prefix/mask* — Specifies the IP prefix and host bits.

**Values** host bits: must be 0  
mask: 0 — 32

**vc-type** — Specifies the VC type signaled for the spoke or mesh binding to the far end of an SDP. The VC type is a 15 bit-quantity containing a value which represents the type of VC. The actual signaling of the VC type depends on the signaling parameter defined for the SDP. If signaling is disabled, the **vc-type** command can still be used to define the Dot1q value expected by the far-end provider equipment. A change of the binding's VC type causes the binding to signal the new VC type to the far end when signaling is enabled.

VC types are derived according to IETF *draft-martini-l2circuit-trans-mpls*.

- Ethernet — The VC type value for Ethernet is 0x0005.
- VLAN — The VC type value for an Ethernet VLAN is 0x0004.

*vc-id* — Specifies the virtual circuit identifier.

**Values** 1 — 4294967295

## instance

**Syntax** **instance**

**Context** tools>dump>router>ldp

**Description** This command displays information for an LDP instance.

## memory-usage

**Syntax** **memory-usage**

**Context** tools>dump>router>ldp

**Description** This command displays memory usage information for LDP.

**Default** none

## session

<b>Syntax</b>	<b>session</b> [ <i>ip-address</i>   : <i>label space</i> ] [ <i>connection</i>   <i>peer</i>   <i>adjacency</i> ]
<b>Context</b>	tools>dump>router>ldp
<b>Description</b>	This command displays information for an LDP session.
<b>Default</b>	none
<b>Parameters</b>	<i>ip-address</i> — Specifies the IP address of the LDP peer. <i>label-space</i> — Specifies the label space identifier that the router is advertising on the interface. <b>connection</b> — Displays connection information. <b>peer</b> — Displays peer information. <b>adjacency</b> — Displays hello adjacency information.

## sockets

<b>Syntax</b>	<b>sockets</b>
<b>Context</b>	tools>dump>router>ldp
<b>Description</b>	This command displays information for all sockets being used by the LDP protocol.
<b>Default</b>	none

## timers

<b>Syntax</b>	<b>timers</b>
<b>Context</b>	tools>dump>router>ldp
<b>Description</b>	This command displays timer information for LDP.
<b>Default</b>	none

## mpls

<b>Syntax</b>	<b>mpls</b>
<b>Context</b>	tools>dump>router
<b>Description</b>	This command enables the context to display MPLS information.
<b>Default</b>	none

## ftn

<b>Syntax</b>	<b>ftn</b>
<b>Context</b>	tools>dump>router>mpls
<b>Description</b>	This command displays FEC-to-NHLFE (FTN) dump information for MPLS. (NHLFE is the acronym for Next Hop Label Forwarding Entry.)
<b>Default</b>	none

## ilm

<b>Syntax</b>	<b>ilm</b>
<b>Context</b>	tools>dump>router>mpls
<b>Description</b>	This command displays incoming label map (ILM) information for MPLS.
<b>Default</b>	none

## lspinfo

<b>Syntax</b>	<b>lspinfo</b> [ <i>lsp-name</i> ] [ <b>detail</b> ]
<b>Context</b>	tools>dump>router>mpls
<b>Description</b>	This command displays label-switched path (LSP) information for MPLS.
<b>Default</b>	none
<b>Parameters</b>	<i>lsp-name</i> — Specifies the name that identifies the LSP. The LSP name can be up to 32 characters long and must be unique. <b>detail</b> — Displays detailed information about the LSP.

## memory-usage

<b>Syntax</b>	<b>memory-usage</b>
<b>Context</b>	tools>dump>router>mpls
<b>Description</b>	This command displays memory usage information for MPLS.
<b>Default</b>	none

## te-lspinfo

<b>Syntax</b>	<b>te-lspinfo</b> [endpoint <i>ip-address</i> ] [sender <i>ip-address</i> ] [ <i>lspid lsp-id</i> ] [detail] [p2p   p2p-tid <i>tunnel-id</i> ] <b>te-lspinfo</b> [endpoint <i>ip-address</i> ] [sender <i>ip-address</i> ] [ <i>lspid lsp-id</i> ] [detail] [p2p   p2p-tid <i>tunnel-id</i> ]{ [phops] [nhops] [s2l <i>ip-address</i> ] }
<b>Context</b>	tools>dump>router>mpls
<b>Description</b>	This command displays TE LSP information for MPLS.
<b>Default</b>	none

### Sample Output

```

E:Dut-R# tools dump router mpls te-lspinfo
Key P2P: Session(10.10.3.2, 201, 3.3.3.3) Sender(3.3.3.3, 2) PHOP(10.10.3.1), Flags
0x0

Key P2P: Session(10.10.3.1, 1035, 4.4.4.4) Sender(4.4.4.4, 22) PHOP(10.10.11.2),
Flags 0x0

Key P2MP: Session(0.0.0.0, 1, 4.4.4.4) Sender(4.4.4.4, 52226) PHOP(0.0.0.0) Flags
0x10
  S2L [1] Key: endPoint to 2.2.2.2 subGroupId - 1 subGroupOrigId - 4.4.4.4
  S2L [2] Key: endPoint to 10.10.2.2 subGroupId - 3 subGroupOrigId - 4.4.4.4
  S2L [3] Key: endPoint to 10.10.13.2 subGroupId - 4 subGroupOrigId - 4.4.4.4

Key P2MP: Session(0.0.0.0, 2, 4.4.4.4) Sender(4.4.4.4, 51714) PHOP(0.0.0.0) Flags
0x10
  S2L [1] Key: endPoint to 2.2.2.2 subGroupId - 1 subGroupOrigId - 4.4.4.4
  S2L [2] Key: endPoint to 10.10.2.2 subGroupId - 3 subGroupOrigId - 4.4.4.4
  S2L [3] Key: endPoint to 10.10.13.2 subGroupId - 4 subGroupOrigId - 4.4.4.4

Key P2MP: Session(0.0.0.0, 3, 4.4.4.4) Sender(4.4.4.4, 53250) PHOP(0.0.0.0) Flags
0x10

*A:Dut-T# tools dump router mpls te-lspinfo p2mp-tid 102 nhops

  Key P2MP: Session(0.0.0.0, 102, 4.4.4.4) Sender(4.4.4.4, 3074) PHOP(0.0.0.0) Flags
0x10
  -----
  List of NEXT HOPS
  -----

  NextHop [1] =>
  Key: Nhop - isFrr 0, outIf 0, NextHop 0.0.0.0 label - 128843 global Instance 0 is
Leaf node
  -----
  Primary NHLFE => outLabel - 0 and NextHop - 0.0.0.0, outIf 0 (0)
  Port(NONE) NhIdx 0, ProtNhIdx 0, NumS2L 1
  ProtectInstance - 0, ProtectGroup 0
  POP
  No Backup NHLFEs for this Ltn entry
  Mid List : 3428 numS2Ls - 1 (Primary MID),

  NextHop [2] =>
  Key: Nhop - isFrr 0, outIf 3, NextHop 10.10.13.2 label - 128806 global Instance -

```

```

48747
-----
Primary NHLFE => outLabel - 128806 and NextHop - 10.10.13.2, outIf 3 (126)
      Port(9/1/1) NhIdx 4322, ProtNhIdx 2275, NumS2L 1
      ProtectInstance - 1, ProtectGroup 126
SWAP
Backup NHLFE => outLabel - 130223 and NextHop - 10.10.3.2, outIf 5 (124)
      Port(9/2/3) outPushLabel 128806, NhIdx 5469, ProtNhIdx 0, NumS2L 1
Mid List :      3428 numS2Ls - 1 (Primary MID),

NextHop [3] =>
Key: Nhop - isFrr 0, outIf 4, NextHop 10.10.2.2 label - 128836 global Instance -
48974
-----
Primary NHLFE => outLabel - 128836 and NextHop - 10.10.2.2, outIf 4 (125)
      Port(lag-1) NhIdx 4292, ProtNhIdx 2245, NumS2L 2
      ProtectInstance - 1, ProtectGroup 125
SWAP
Backup NHLFE => outLabel - 130223 and NextHop - 10.10.3.2, outIf 5 (124)
      Port(9/2/3) outPushLabel 128836, NhIdx 5659, ProtNhIdx 0, NumS2L 2
Mid List :      3428 numS2Ls - 1 (Primary MID),      3471 numS2Ls - 1 (Backup MID),

S2L [1] Key: endPoint to 2.2.2.2 subGroupId - 1 subGroupOrigId - 4.4.4.4
S2L [2] Key: endPoint to 3.3.3.3 subGroupId - 2 subGroupOrigId - 4.4.4.4
S2L [3] Key: endPoint to 10.10.2.2 subGroupId - 3 subGroupOrigId - 4.4.4.4
S2L [4] Key: endPoint to 10.10.13.2 subGroupId - 4 subGroupOrigId - 4.4.4.4

Total TeLspInfo Count      : 1

```

## ospf

**Syntax** `ospf [ospf-instance]`

**Context** `tools>dump>router`

**Description** This command enables the context to display tools information for OSPF.

**Default** none

**Parameters** `ospf-instance` — OSPF instance.

**Values** 1 — 4294967295

## ospf3

**Syntax** `ospf3`

**Context** `tools>dump>router`

**Description** This command enables the context to display tools information for OSPF3.

**Default** none

## Router Commands

### abr

<b>Syntax</b>	<b>abr [detail]</b>
<b>Context</b>	tools>dump>router>ospf tools>dump>router>ospf3
<b>Description</b>	This command displays area border router (ABR) information for OSPF.
<b>Default</b>	none
<b>Parameters</b>	<b>detail</b> — Displays detailed information about the ABR.

### asbr

<b>Syntax</b>	<b>asbr [detail]</b>
<b>Context</b>	tools>dump>router>ospf tools>dump>router>ospf3
<b>Description</b>	This command displays autonomous system border router (ASBR) information for OSPF.
<b>Default</b>	none
<b>Parameters</b>	<b>detail</b> — Displays detailed information about the ASBR.

### bad-packet

<b>Syntax</b>	<b>bad-packet [interface-name]</b>
<b>Context</b>	tools>dump>router>ospf tools>dump>router>ospf3
<b>Description</b>	This command displays information about bad packets for OSPF.
<b>Default</b>	none
<b>Parameters</b>	<i>interface-name</i> — Display only the bad packets identified by this interface name.

### leaked-routes

<b>Syntax</b>	<b>leaked-routes [summary   detail]</b>
<b>Context</b>	tools>dump>router>ospf tools>dump>router>ospf3
<b>Description</b>	This command displays information about leaked routes for OSPF.
<b>Default</b>	summary
<b>Parameters</b>	<b>summary</b> — Display a summary of information about leaked routes for OSPF.

**detail** — Display detailed information about leaked routes for OSPF.

## memory-usage

<b>Syntax</b>	<b>memory-usage [detail]</b>
<b>Context</b>	tools>dump>router>ospf tools>dump>router>ospf3
<b>Description</b>	This command displays memory usage information for OSPF.
<b>Default</b>	none
<b>Parameters</b>	<b>detail</b> — Displays detailed information about memory usage for OSPF.

## request-list

<b>Syntax</b>	<b>request-list [neighbor <i>ip-address</i>] [detail]</b> <b>request-list virtual-neighbor <i>ip-address area-id area-id</i> [detail]</b>
<b>Context</b>	tools>dump>router>ospf tools>dump>router>ospf3
<b>Description</b>	This command displays request list information for OSPF.
<b>Default</b>	none
<b>Parameters</b>	<b>neighbor <i>ip-address</i></b> — Display neighbor information only for neighbor identified by the IP address. <b>detail</b> — Displays detailed information about the neighbor. <b>virtual-neighbor <i>ip-address</i></b> — Displays information about the virtual neighbor identified by the IP address. <b>area-id <i>area-id</i></b> — The OSPF area ID expressed in dotted decimal notation or as a 32-bit decimal integer.

## retransmission-list

<b>Syntax</b>	<b>retransmission-list [neighbor <i>ip-address</i>] [detail]</b> <b>retransmission-list virtual-neighbor <i>ip-address area-id area-id</i> [detail]</b>
<b>Context</b>	tools>dump>router>ospf tools>dump>router>ospf3
<b>Description</b>	This command displays dump retransmission list information for OSPF.
<b>Default</b>	none
<b>Parameters</b>	<b>neighbor <i>ip-address</i></b> — Display neighbor information only for neighbor identified by the IP address. <b>detail</b> — Displays detailed information about the neighbor.

## Router Commands

**virtual-neighbor** *ip-address* — Displays information about the virtual neighbor identified by the IP address.

**area-id** *area-id* — The OSPF area ID expressed in dotted decimal notation or as a 32-bit decimal integer.

### route-summary

<b>Syntax</b>	<b>route-summary</b>
<b>Context</b>	tools>dump>router>ospf tools>dump>router>ospf3
<b>Description</b>	This command displays dump route summary information for OSPF.
<b>Default</b>	none

### route-table

<b>Syntax</b>	<b>route-table [type] [detail]</b>
<b>Context</b>	tools>dump>router>ospf tools>dump>router>ospf3
<b>Description</b>	This command displays dump information about routes learned through OSPF.
<b>Default</b>	none
<b>Parameters</b>	<b>type</b> — Specify the type of route table to display information. <b>Values</b> intra-area, inter-area, external-1, external-2, nssa-1, nssa-2 <b>detail</b> — Displays detailed information about learned routes.

### pim

<b>Syntax</b>	<b>pim</b>
<b>Context</b>	tools>dump>router
<b>Description</b>	This command enables the context to display PIM information.

### iom-failures

<b>Syntax</b>	<b>iom-failures [detail]</b>
<b>Context</b>	tools>dump>router>pim
<b>Description</b>	This command displays information about failures in programming IOMs.

**Parameters** *detail* — Displays detailed information about IOM failures.

## rsvp

**Syntax** rsvp

**Context** tools>dump>router

**Description** This command enables the context to display RSVP information.

**Default** none

## psb

**Syntax** **psb** [**endpoint** *endpoint-address*] [**sender** *sender-address*] [**tunnelid** *tunnel-id*] [**lspid** *lsp-id*]

**Context** tools>dump>router>rsvp

**Description** This command displays path state block (PSB) information for RSVP.

When a PATH message arrives at an LSR, the LSR stores the label request in the local PSB for the LSP. If a label range is specified, the label allocation process must assign a label from that range.

The PSB contains the IP address of the previous hop, the session, the sender, and the TSPEC. This information is used to route the corresponding RESV message back to LSR 1.

**Default** none

**Parameters** **endpoint** *endpoint-address* — Specifies the IP address of the last hop.

**sender** *sender-address* — Specifies the IP address of the sender.

**tunnelid** *tunnel-id* — Specifies the SDP ID.

**Values** 0 — 4294967295

**lspid** *lsp-id* — Specifies the label switched path that is signaled for this entry.

**Values** 1 — 65535

## rsb

**Syntax** **rsb** [**endpoint** *endpoint-address*] [**sender** *sender-address*] [**tunnelid** *tunnel-id*] [**lspid** *lsp-id*]

**Context** tools>dump>router>rsvp

**Description** This command displays RSVP Reservation State Block (RSB) information.

**Default** none

**Parameters** **endpoint** *endpoint-address* — Specifies the IP address of the last hop.

**sender** *sender-address* — Specifies the IP address of the sender.

## Router Commands

**tunnelid** *tunnel-id* — Specifies the SDP ID.

**Values** 0 — 4294967295

**lspid** *lsp-id* — Specifies the label switched path that is signaled for this entry.

**Values** 1 — 65535

## tcsb

<b>Syntax</b>	<b>tcsb</b> [ <b>endpoint</b> <i>endpoint-address</i> ] [ <b>sender</b> <i>sender-address</i> ] [ <b>tunnelid</b> <i>tunnel-id</i> ] [ <b>lspid</b> <i>lsp-id</i> ]
<b>Context</b>	tools>dump>router>rsvp
<b>Description</b>	This command displays RSVP traffic control state block (TCSB) information.
<b>Default</b>	none
<b>Parameters</b>	<b>endpoint</b> <i>endpoint-address</i> — Specifies the IP address of the egress node for the tunnel supporting this session. <b>sender</b> <i>sender-address</i> — Specifies the IP address of the sender node for the tunnel supporting this session. It is derived from the source address of the associated MPLS LSP definition. <b>tunnelid</b> <i>tunnel-id</i> — Specifies the IP address of the ingress node of the tunnel supporting this RSVP session. <b>Values</b> 0 — 4294967295 <b>lspid</b> <i>lsp-id</i> — Specifies the label switched path that is signaled for this entry. <b>Values</b> 1 — 65535

## static-route

<b>Syntax</b>	<b>static-route</b> <b>ldp-sync-status</b>
<b>Context</b>	tools>dump>router
<b>Description</b>	This command displays the sync status of LDP interfaces that static-route keeps track of.

## web-rd

<b>Syntax</b>	<b>web-rd</b>
<b>Context</b>	tools>dump>router
<b>Description</b>	This command enables the context to display tools for web redirection.

## http-client

<b>Syntax</b>	<b>http-client</b> [ <i>ip-prefix/mask</i> ]
<b>Context</b>	tools>dump>router>web-rd
<b>Description</b>	This command displays the HTTP client hash table.
<b>Parameters</b>	<i>ip-prefix/mask</i> — Specifies the IP prefix and host bits.
<b>Values</b>	host bits: must be 0 mask: 0 — 32

## Performance Tools

### perform

<b>Syntax</b>	perform
<b>Context</b>	tools
<b>Description</b>	This command enables the context to enable tools to perform specific tasks.
<b>Default</b>	none

### cron

<b>Syntax</b>	<b>cron</b>
<b>Context</b>	tools>perform
<b>Description</b>	This command enables the context to perform CRON (scheduling) control operations.
<b>Default</b>	none

### action

<b>Syntax</b>	<b>action</b>
<b>Context</b>	tools>perform>cron
<b>Description</b>	This command enables the context to stop the execution of a script started by CRON action. See the <b>stop</b> command.

### stop

<b>Syntax</b>	<b>stop</b> [ <i>action-name</i> ] [ <b>owner</b> <i>action-owner</i> ] [ <b>all</b> ]
<b>Context</b>	tools>perform>cron>action
<b>Description</b>	This command stops execution of a script started by CRON action.
<b>Parameters</b>	<i>action-name</i> — Specifies the action name. <b>Values</b> Maximum 32 characters. <i>owner action-owner</i> — Specifies the owner name. <b>Default</b> TiMOS CLI <b>all</b> — Specifies to stop all CRON scripts.

## tod

<b>Syntax</b>	<b>tod</b>
<b>Context</b>	tools>perform>cron
<b>Description</b>	This command enables the context for tools for controlling time-of-day actions.
<b>Default</b>	none

## re-evaluate

<b>Syntax</b>	<b>re-evaluate</b>
<b>Context</b>	tools>perform>cron>tod
<b>Description</b>	This command enables the context to re-evaluate the time-of-day state.
<b>Default</b>	none

## customer

<b>Syntax</b>	<b>customer</b> <i>customer-id</i> [ <b>site</b> <i>customer-site-name</i> ]
<b>Context</b>	tools>perform>cron>tod>re-eval
<b>Description</b>	This command re-evaluates the time-of-day state of a multi-service site.
<b>Parameters</b>	<i>customer-id</i> — Specify an existing customer ID. <b>Values</b> 1 — 2147483647 <i>site customer-site-name</i> — Specify an existing customer site name.

## filter

<b>Syntax</b>	<b>filter</b> <i>filter-type</i> [ <i>filter-id</i> ]
<b>Context</b>	tools>perform>cron>tod>re-eval
<b>Description</b>	This command re-evaluates the time-of-day state of a filter entry.
<b>Parameters</b>	<i>filter-type</i> — Specify the filter type. <b>Values</b> ip-filter, ipv6-filter, mac-filter <i>filter-id</i> — Specify an existing filter ID. <b>Values</b> 1 — 65535

## service

<b>Syntax</b>	<b>service id</b> <i>service-id</i> [ <b>sap</b> <i>sap-id</i> ]
<b>Context</b>	tools>perform>cron>tod>re-eval
<b>Description</b>	This command re-evaluates the time-of-day state of a SAP.
<b>Parameters</b>	<b>id</b> <i>service-id</i> — Specify the an existing service ID. <b>Values</b> 1 — 2147483647 <b>sap</b> <i>sap-id</i> — Specifies the physical port identifier portion of the SAP definition. See <a href="#">Common CLI Command Descriptions on page 327</a> for CLI command syntax.

## tod-suite

<b>Syntax</b>	<b>tod-suite</b> <i>tod-suite-name</i>
<b>Context</b>	tools>perform>cron>tod>re-eval
<b>Description</b>	This command re-evaluates the time-of-day state for the objects referring to a tod-suite.
<b>Parameters</b>	<i>tod-suite-name</i> — Specify an existing TOD nfname.

## aps

<b>Syntax</b>	<b>aps</b>
<b>Context</b>	tools>perform
<b>Description</b>	This command enables the context to perform Automated Protection Switching (APS) operations.

## clear

<b>Syntax</b>	<b>clear</b> <i>aps-id</i> { <b>protect</b>   <b>working</b> }
<b>Context</b>	tools>perform>aps
<b>Description</b>	This command removes all Automated Protection Switching (APS) operational commands.
<b>Parameters</b>	<i>aps-id</i> — This option clears a specific APS on un-bundled SONET/SDH ports. <b>protect</b> — This command clears a physical port that is acting as the protection circuit for the APS group. <b>working</b> — This command clears a physical port that is acting as the working circuit for this APS group.

## exercise

<b>Syntax</b>	<b>exercise</b> <i>aps-id</i> { <b>protect</b>   <b>working</b> }
<b>Context</b>	tools>perform
<b>Description</b>	This command performs an exercise request on the protection or working circuit.
<b>Parameters</b>	<p><i>aps-id</i> — This option clears a specific APS on un-bundled SONET/SDH ports.</p> <p><b>protect</b> — This command performs an exercise request on the port that is acting as the protection circuit for the APS group.</p> <p><b>working</b> — This command performs an exercise request on the port that is acting as the working circuit for this APS group.</p>

## force

<b>Syntax</b>	<b>force</b> <i>aps-id</i> { <b>protect</b>   <b>working</b> }
<b>Context</b>	tools>perform
<b>Description</b>	This command forces a switch to either the protect or working circuit
<b>Parameters</b>	<p><i>aps-id</i> — This option clears a specific APS on un-bundled SONET/SDH ports.</p> <p><b>protect</b> — This command clears a physical port that is acting as the protection circuit for the APS group.</p> <p><b>working</b> — This command clears a physical port that is acting as the working circuit for this APS group.</p>

## lockout

<b>Syntax</b>	<b>lockout</b> <i>aps-id</i>
<b>Context</b>	tools>perform
<b>Description</b>	This command locks out the protection circuit.
<b>Parameters</b>	<p><i>aps-id</i> — Automated Protection Switching ID</p> <p><b>Values</b>      1 — 64</p>

## request

<b>Syntax</b>	<b>request</b> <i>aps-id</i> { <b>protect</b>   <b>working</b> }
<b>Context</b>	tools>perform
<b>Description</b>	This command requests a manual switch to protection or working circuit.

## Performance Tools

- Parameters**
- aps-id* — This option clears a specific APS on un-bundled SONET/SDH ports.
  - protect** — This command requests a manual switch to a port that is acting as the protection circuit for the APS group.
  - working** — This command requests a manual switch to a port that is acting as the working circuit for this APS group.

## consistency

- Syntax** **consistency**
- Context** tools>perform>router
- Description** This command performs route table manager (RTM) consistency checks.
- Default** none

## ldp-sync-exit

- Syntax** **[no] ldp-sync-exit**
- Context** tools>perform>router>isis  
tools>perform>router>ospf
- Description** This command restores the actual cost of an interface at any time. When this command is executed, IGP immediately advertises the actual value of the link cost for all interfaces which have the IGP-LDP synchronization enabled if the currently advertised cost is different.

## isis

- Syntax** **isis**
- Context** tools>perform>router
- Description** This command enables the context to configure tools to perform certain ISIS tasks.

## run-manual-spf

- Syntax** **run-manual-spf**
- Context** tools>perform>router>isis
- Description** This command runs the Shortest Path First (SPF) algorithm.

## mpls

<b>Syntax</b>	<b>mpls</b>
<b>Context</b>	tools>perform>router
<b>Description</b>	This command enables the context to perform specific MPLS tasks.
<b>Default</b>	none

## cspf

<b>Syntax</b>	<b>cspf to <i>ip-addr</i> [from <i>ip-addr</i>] [bandwidth <i>bandwidth</i>] [include-bitmap <i>bitmap</i>] [exclude-bitmap <i>bitmap</i>] [hop-limit <i>limit</i>] [exclude-address <i>excl-addr</i> [<i>excl-addr</i>...(up to 8 max)]] [use-te-metric] [strict-srlg] [srlg-group <i>grp-id</i>...(up to 8 max)] [exclude-node <i>excl-node-id</i> [<i>excl-node-id</i> ..(up to 8 max)]] [skip-interface <i>interface-name</i>] [ds-class-type <i>class-type</i>] [cspf-reqtype <i>req-type</i>] [least-fill-min-thd <i>thd</i>] [setup-priority <i>val</i>] [hold-priority <i>val</i>]</b>
<b>Context</b>	tools>perform>router>mpls
<b>Description</b>	This command computes a CSPF path with specified user constraints.
<b>Default</b>	none
<b>Parameters</b>	<p><b>to <i>ip-addr</i></b> — Specify the destination IP address.</p> <p><b>from <i>ip-addr</i></b> — Specify the originating IP address.</p> <p><b>bandwidth <i>bandwidth</i></b> — Specifies the amount of bandwidth in mega-bits per second (Mbps) to be reserved.</p> <p><b>include-bitmap <i>bitmap</i></b> — Specifies to include a bit-map that specifies a list of admin groups that should be included during setup.</p> <p><b>exclude-bitmap <i>bitmap</i></b> — Specifies to exclude a bit-map that specifies a list of admin groups that should be included during setup.</p> <p><b>hop-limit <i>limit</i></b> — Specifies the total number of hops a detour LSP can take before merging back onto the main LSP path.</p> <p><b>exclude-address <i>ip-addr</i></b> — Specifies an IP address to exclude from the operation.</p> <p><b>skip-interface <i>interface-name</i></b> — Specifies a local interface name, instead of the interface address, to be excluded from the CSPF computation.</p> <p><b>ds-class-type <i>class-type</i></b> — Specifies the class type.</p> <p><b>Values</b>      0 — 7</p> <p><b>cspf-reqtype <i>req-ty</i></b> — Specifies the CSPF request type.</p> <p><b>Values</b>      all — Specifies all ECMP paths.  random — Specifies random ECMP paths.  least-fill — Specifies minimum fill path.</p>

## resignal

<b>Syntax</b>	<b>resignal lsp</b> <i>lsp-name</i> <b>path</b> <i>path-name</i> <b>delay</b> <i>minutes</i> <b>resignal</b> { <b>p2mp-lsp</b> <i>p2mp-lsp-name</i> <b>p2mp-instance</b> <i>p2mp-instance-name</i>   <b>p2mp-delay</b> <i>p2mp-minutes</i> }
<b>Context</b>	tools>perform>router>mpls
<b>Description</b>	Use this command to resignal a specific LSP path.
<b>Default</b>	none
<b>Parameters</b>	<b>lsp</b> <i>lsp-name</i> — Specifies the name that identifies the LSP. The LSP name can be up to 32 characters long and must be unique. <b>path</b> <i>path-name</i> — Specifies the name for the LSP path up, to 32 characters in length. <b>delay</b> <i>minutes</i> — Specifies the resignal delay in minutes. <b>Values</b> 0 — 30 <b>p2mp-lsp</b> <i>p2mp-lsp-name</i> — Specifies an existing point-to-multipoint LSP name. <b>p2mp-instance</b> <i>p2mp-instance-name</i> — Specifies a name that identifies the P2MP LSP instance <b>p2mp-delay</b> <i>p2mp-minutes</i> — Specifies the delay time, in minutes. <b>Values</b> 0 — 60

## trap-suppress

<b>Syntax</b>	<b>trap-suppress</b> [ <i>number-of-traps</i> ] [ <i>time-interval</i> ]
<b>Context</b>	tools>perform>router>mpls
<b>Description</b>	This command modifies thresholds for trap suppression.
<b>Default</b>	none
<b>Parameters</b>	<i>number-of-traps</i> — Specify the number of traps in multiples of 100. An error messages is generated if an invalid value is entered. <b>Values</b> 100 to 1000 <i>time-interval</i> — Specify the timer interval in seconds. <b>Values</b> 1 — 300

## ospf

<b>Syntax</b>	ospf
<b>Context</b>	tools>perform>router
<b>Description</b>	This command enables the context to perform specific OSPF tasks.

**Default** none

## ospf3

**Syntax** ospf3

**Context** tools>perform>router

**Description** This command enables the context to perform specific OSPF3 tasks.

**Default** none

## refresh-lsas

**Syntax** refresh-lsas [*lsa-type*] [*area-id*]

**Context** tools>perform>router>ospf  
tools>perform>router>ospf3

**Description** This command refreshes LSAs for OSPF.

**Default** none

**Parameters** *lsa-type* — Specify the LSA type using allow keywords.

**Values** router, network, summary, asbr, extern, nssa, opaque

*area-id* — The OSPF area ID expressed in dotted decimal notation or as a 32-bit decimal integer.

**Values** 0 — 4294967295

## run-manual-spf

**Syntax** run-manual-spf *externals-only*

**Context** tools>perform>router>ospf  
tools>perform>router>ospf3

**Description** This command runs the Shortest Path First (SPF) algorithm.

**Default** none

**Parameters** *externals-only* — Specify the route preference for OSPF external routes.

## security

- Syntax** **security**
- Context** tools>perform
- Description** This command provides tools for testing security.

## authentication-server-check

- Syntax** **authentication-server-check** *server-address ip-address* [**port** *port*] **user-name** *DHCP client user name* **password** *password* **secret** *key* [**source-address** *ip-address*] [**timeout** *seconds*] [**router** *router-instance*]
- Context** tools>perform>security
- Description** This command checks connection to the RADIUS server.
- Parameters** **router** *router-instance* — Specifies the router name or service ID.
- |                |                     |                   |
|----------------|---------------------|-------------------|
| <b>Values</b>  | <i>router-name:</i> | Base , management |
|                | <i>service-id:</i>  | 1 — 2147483647    |
| <b>Default</b> |                     | Base              |

## service

- Syntax** **services**
- Context** tools>perform
- Description** This command enables the context to configure tools for services.

## egress-multicast-group

- Syntax** **egress-multicast-group** *group-name*
- Context** tools>perform>service
- Description** This command enables the context to configure tools for egress multicast groups.
- Parameters** *group-name* — Specify an existing group name.

## force-optimize

<b>Syntax</b>	<b>force-optimize</b>
<b>Context</b>	tools>perform>service>egress-multicast-group
<b>Description</b>	This command optimizes the chain length.

## eval-pw-template

<b>Syntax</b>	<b>eval-pw-template</b> <i>policy-id</i> [ <b>allow-service-impact</b> ]
<b>Context</b>	tools>perform>service>egress-multicast-group tools>perform>service>id
<b>Description</b>	This command re-evaluates the pseudowire template policy.
<b>Parameters</b>	<i>policy-id</i> — Specifies the pseudowire template policy. <b>allow-service-impact</b> —

## id

<b>Syntax</b>	<b>id</b> <i>service-id</i>
<b>Context</b>	tools>perform>service
<b>Description</b>	This command enables the context to configure tools for a specific service.
<b>Parameters</b>	<i>service-id</i> — Specify an existing service ID. <b>Values</b> 1 — 2147483647

## endpoint

<b>Syntax</b>	<b>endpoint</b> <i>endpoint-name</i>
<b>Context</b>	tools>perform>service>id
<b>Description</b>	This command enables the context to configure tools for a specific VLL service endpoint.
<b>Parameters</b>	<i>endpoint-name</i> — Specify an existing VLL service endpoint name.

## force-switchover

- Syntax** **force-switchover** *sdp-id:vc-id*  
**no force-switchover**
- Context** tools>perform>service>id
- Description** This command forces a switch of the active spoke SDP for the specified service.
- Parameters** *sdp-id:vc-id* — Specify an existing spoke SDP for the service.

### Sample Output

```
A:Dut-B# tools perform service id 1 endpoint mcep-t1 force-switchover 221:1
*A:Dut-B# show service id 1 endpoint
=====
Service 1 endpoints
=====
Endpoint name           : mcep-t1
Description             : (Not Specified)
Revert time            : 0
Act Hold Delay         : 0
Ignore Standby Signaling : false
Suppress Standby Signaling : false
Block On Mesh Fail     : true
Multi-Chassis Endpoint : 1
MC Endpoint Peer Addr  : 3.1.1.3
Psv Mode Active        : No
Tx Active              : 221:1 (forced)
Tx Active Up Time      : 0d 00:00:17
Revert Time Count Down : N/A
Tx Active Change Count : 6
Last Tx Active Change  : 02/14/2009 00:17:32
-----
Members
-----
Spoke-sdp: 221:1 Prec:1                               Oper Status: Up
Spoke-sdp: 231:1 Prec:2                               Oper Status: Up
=====
*A:Dut-B#
```

## mcac

- Syntax** **mcac sap** *sap-id recalc policy policy-name* [**bundle** *bundle-name*]  
**mcac sdp** *sdp-id:vc-id recalc policy policy-name* [**bundle** *bundle-name*]
- Context** tools>perform>service>id
- Description** This command enables too for a multicast CAC.
- Parameters** **sap** *sap-id* — Specifies the SAP ID.  
**recalc** — keyword  
**policy** *policy-name* — Specifies the policy name.

**bundle** *bundle-name* — Specifies the bundle name.

## subscriber-mgmt

<b>Syntax</b>	<b>subscriber-mgmt</b>
<b>Context</b>	tools>perform
<b>Description</b>	This command enables tools to control subscriber management.

## edit-lease-state

<b>Syntax</b>	<b>edit-lease-state sap</b> <i>sap-id</i> <b>ip</b> <i>ip-address</i> [ <b>subscriber</b> <i>sub-ident-string</i> ] [ <b>sub-profile-string</b> <i>sub-profile-string</i> ] [ <b>sla-profile-string</b> <i>sla-profile-string</i> ] <b>edit-lease-state svc-id</b> <i>service-id</i> <b>ip</b> <i>ip-address</i> [ <b>subscriber</b> <i>sub-ident-string</i> ] [ <b>sub-profile-string</b> <i>sub-profile-string</i> ] [ <b>sla-profile-string</b> <i>sla-profile-string</i> ]
<b>Context</b>	tools>perform>subscr-mgmt
<b>Parameters</b>	<b>sap</b> <i>sap-id</i> — Specifies the physical port identifier portion of the SAP definition. See <a href="#">Common CLI Command Descriptions on page 327</a> for CLI command syntax. <b>ip</b> <i>ip-address</i> — Modifies lease state information for the specified IP address. <b>subscriber</b> <i>sub-ident-string</i> — Modifies lease state information for the specified subscriber ID. <b>sub-profile-string</b> <i>sub-profile-string</i> — Modifies lease state information for the specified subscriber profile. <b>sla-profile-string</b> <i>sla-profile-string</i> — Modifies lease state information for the SLA profile. <b>svc-id</b> <i>service-id</i> — Modifies lease state information for the specified service ID. <b>Values</b> 1 — 2147483647

## eval-lease-state

<b>Syntax</b>	<b>eval-lease-state</b> [ <b>svc-id</b> <i>service-id</i> ] [ <b>sap</b> <i>sap-id</i> ] [ <b>subscriber</b> <i>sub-ident-string</i> ] [ <b>ip</b> <i>ip-address</i> ]
<b>Context</b>	tools>perform>subscr-mgmt
<b>Description</b>	This command evaluates lease state information.
<b>Parameters</b>	<b>svc-id</b> <i>service-id</i> — Evaluates lease state information for the specified service. <b>Values</b> 1 — 2147483647 <b>sap</b> <i>sap-id</i> — Evaluates lease state information for the specified SAP. See <a href="#">Common CLI Command Descriptions on page 327</a> for CLI command syntax. <b>subscriber</b> <i>sub-ident-string</i> — Evaluates lease state information for the specified subscriber identification string.

**ip *ip-address*** — Evaluates lease state information for the specified IP address.

## forcerenew

**Syntax** **forcerenew *svc-id service-id* {**ip** *ip-address[/mask]* | **mac** *ieee-address*}**  
**forcerenew {**interface** *interface-name* | **sap** *sap-id* | **sdp** *sdp-id:vc-id*} [**ip** *ip-address[/mask]* | **mac** *ieee-address*]**

**Context** tools>perform>subscr-mgmt

**Description** This command forces the renewal of lease state.

**Parameters** **svc-id *service-id*** — Forces renewal of the lease state for the specified service.

**Values** 1 — 2147483647

**sap *sap-id*** — Forces renewal of the lease state for the specified SAP. See [Common CLI Command Descriptions on page 327](#) for CLI command syntax.

**ip *ip-address*** — Forces renewal of the lease state for the specified IP address.

**mac *ieee-address*** — Forces renewal of the lease state for the specified MAC address.

**interface *interface-name*** — Forces renewal of the lease state for the specified interface name.

## re-ident-sub

**Syntax** **re-ident-sub *old-sub-ident-string* to *new-sub-ident-string***

**Context** tools>perform>subscr-mgmt

**Description** This command renames a subscriber identification string.

**Parameters** ***old-sub-ident-string*** — Specifies the existing subscriber identification string to be renamed.

***new-sub-ident-string*** — Specifies the new subscriber identification string name.

## remap-lease-state

**Syntax** **remap-lease-state **old-mac** *ieee-address* **mac** *ieee-address***  
**remap-lease-state **sap** *sap-id* [**mac** *ieee-address*]**

**Context** tools>perform>subscr-mgmt

**Description** This command allows the remapping of all existing hosts if network card on CMTS/WAC side is changed is required.

When this command is executed, the following restrictions apply

- When **sap** is taken, all leases associated with the SAP are re-written.
  - For a SAP with a configured MAC in "lease-populate" command, this MAC will be taken.
  - For a SAP without a configured MAC the MAC from tools command will be taken.
  - For a SAP without a configured MAC and no MAC in tools command no action will be perform.
- When using the **old-mac** option, providing a new MAC *ieee-address* is mandatory.

This command is applicable only when dealing with DHCP lease states which were instantiated using l2header mode of DHCP operation.

### Parameters

**old-mac** *ieee-address*

**old-mac** *ieee-address* — specifies the old MAC address to remap.

**mac** *ieee-address* — Specifies that the provisioned MAC address will be used in the anti-spoofing entries for this SAP when l2-header is enabled. The parameter may be changed mid-session. Existing sessions will not be re-programmed unless a **tools perform** command is issued for the lease.

**sap** *sap-id* — Specifies the physical port identifier portion of the SAP definition. See [Common CLI Command Descriptions on page 327](#) for CLI command syntax.

When configured, the SAP parameter will remap all MAC addresses of DHCP lease states on the specified SAP. When no optional MAC parameter is specified, the **sap** *sap-id* command remaps all MAC addresses of lease states towards the MAC address specified in the l2-header configuration.



# Common CLI Command Descriptions

---

## In This Chapter

This chapter provides CLI syntax and command descriptions for SAP and port commands.

Topics in this chapter include:

- [SAP Syntax on page 328](#)
- [Port Syntax on page 332](#)

## Common Service Commands

### sap

**Syntax** [no] sap *sap-id*

**Syntax** [no] sap *sap-id*

**Description** This command specifies the physical port identifier portion of the SAP definition.

**Parameters** *sap-id* — Specifies the physical port identifier portion of the SAP definition.

The *sap-id* can be configured in one of the following formats:

Type	Syntax	Example
port-id	<i>slot/mda/port[.channel]</i>	1/1/5
null	<i>[port-id   bundle-id] bpgrp-id   lag-id   aps-id</i>	<i>port-id:</i> 1/1/3 <i>bundle-id:</i> bundle-ppp-1/1.1 <i>bpgrp-id:</i> bpgrp-ima-1 <i>lag-id:</i> lag-3 <i>aps-id:</i> aps-1
dot1q	<i>[port-id   bundle-id] bpgrp-id   lag-id   aps-id]:qtag1</i>	<i>port-id:qtag1:</i> 1/1/3:100 <i>bundle-id:</i> bundle-ppp-1/1.1 <i>bpgrp-id:</i> bpgrp-ima-1 <i>lag-id:qtag1:</i> lag-3:102 <i>aps-id:qtag1:</i> aps-1:27
qinq	<i>[port-id   bpgrp-id   lag-id]:qtag1.qtag2</i>	<i>port-id:qtag1.qtag2:</i> 1/1/3:100.10 <i>bpgrp-id:</i> bpgrp-ima-1 <i>lag-id:qtag1.qtag2:</i> lag-10:
atm	<i>[port-id   aps-id   bundle-id   bpgrp-id][:vpi/vci   vpi   vpi1.vpi2]</i>	<i>port-id:</i> 1/1/1 <i>aps-id:</i> aps-1 <i>bundle-id:</i> bundle-ima-1/1.1 bundle-ppp-1/1.1 <i>bpgrp-id:</i> bpgrp-ima-1 <i>vpi/vci:</i> 16/26 <i>vpi:</i> 16 <i>vpi1.vpi2:</i> 16.200
frame-relay	<i>[port-id   aps-id]:dlci</i>	<i>port-id:</i> 1/1/1:100 <i>bundle-id:</i> bundle-fr-3/1.1:100 <i>aps-id:</i> aps-1 <i>dlci:</i> 16
cisco-hdlc	<i>slot/mda/port.channel</i>	<i>port-id:</i> 1/1/3.1

7750 SR:

<b>Values:</b> <i>sap-id</i>	null [port-id   bundle-id   bpgrp-id   lag-id   aps-id] dot1q [port-id   bundle-id   bpgrp-id   lag-id   aps-id]:qtag1 qinq [port-id   bundle-id   bpgrp-id   lag-id]:qtag1.qtag2 atm [port-id   aps-id][:vpi/vci vpi vpi1.vpi2] frame [port-id   aps-id]:dlci cisco-hdlc slot/mda/port.channel cem slot/mda/port.channel ima-grp [bundle-id][:vpi/vci vpi vpi1.vpi2] port-id slot/mda/port[.channel] bundle-id bundle-type-slot/mda.bundle-num bundle keyword type ima, fr, ppp bundle-num 1 — 336 bpgrp-id bpgrp-type-bpgrp-num bpgrp keyword type ima, ppp bpgrp-num 1 — 2000 aps-id aps-group-id[.channel] aps keyword group-id 1 — 64 ccag-id ccag-id.path-id[cc-type]:cc-id ccag keyword id 1 — 8 path-id a, b cc-type .sap-net, .net-sap cc-id 0 — 4094 eth-tunnel eth-tunnel-id[:eth-tun-sap-id] id 1 — 1024 eth-tun-sap-id 0 — 4094 lag-id lag-id lag keyword id 1 — 200 qtag1 0 — 4094 qtag2 *, 0 — 4094 vpi NNI: 0 — 4095 UNI: 0 — 255 vci 1, 2, 5 — 65535 dlci 16 — 1022 ipsec-id ipsec-id.[private   public]:tag ipsec keyword id 1 — 4 tag 0 — 4094
------------------------------	--

## Common Service Commands

7710 SR:

**Values:** *sap-id*: null [port-id | bundle-id | bpgrp-id | lag-id | aps-id]  
dot1q [port-id | bundle-id | bpgrp-id | lag-id | aps-id]:qtag1  
qinq [port-id | bundle-id | bpgrp-id | lag-id]:qtag1.qtag2  
atm [port-id | aps-id][:vpi/vci|vpi| vpi1.vpi2]  
frame [port-id | aps-id]:dlci  
cisco-hdlc slot/mda/port.channel  
cem slot/mda/port.channel  
ima-grp [bundle-id[:vpi/vci|vpi|vpi1.vpi2]  
port-id slot/mda/port[.channel]  
bundle-id bundle-type-slot/mda.bundle-num  
bundle keyword  
type ima, ppp  
bundle-num 1 — 256  
bpgrp-id bpgrp-type-bpgrp-num  
bpgrp keyword  
type ima, ppp  
bpgrp-num 1 — 1280  
aps-id aps-group-id[.channel]  
aps keyword  
group-id 1 — 16  
lag-id lag-id  
lag keyword  
id 1 — 64  
qtag1 0 — 4094  
qtag2 \*, 0 — 4094  
vpi NNI: 0 — 4095  
UNI: 0 — 255  
vci 1, 2, 5 — 65535  
dlci 16 — 1022

7450 ESS:

<b>Values:</b> <i>sap-id</i>	null	[ <i>port-id</i>   <i>bundle-id</i>   <i>bpgrp-id</i>   <i>lag-id</i>   <i>aps-id</i> ]
	dot1q	[ <i>port-id</i>   <i>bundle-id</i>   <i>bpgrp-id</i>   <i>lag-id</i>   <i>aps-id</i> ]: <i>qtag1</i>
	qinq	[ <i>port-id</i>   <i>bundle-id</i>   <i>bpgrp-id</i>   <i>lag-id</i> ]: <i>qtag1.qtag2</i>
	atm	[ <i>port-id</i>   <i>aps-id</i> ][: <i>vpi/vci</i>   <i>vpi</i>   <i>vpi1.vpi2</i> ]
	frame	[ <i>port-id</i>   <i>aps-id</i> ]: <i>dldci</i>
	cisco-hdlc	<i>slot/mda/port.channel</i>
	ima-grp	[ <i>bundle-id</i> ][: <i>vpi/vci</i>   <i>vpi</i>   <i>vpi1.vpi2</i> ]
	port-id	<i>slot/mda/port</i> [ <i>.channel</i> ]
	bundle-id	<i>bundle-type-slot/mda.bundle-num</i>
		bundle keyword
		type ima, fr, ppp
		bundle-num 1 — 336
	bpgrp-id	<i>bpgrp-type-bpgrp-num</i>
		bpgrp keyword
		type ima, ppp
		bpgrp-num 1 — 2000
	aps-id	<i>aps-group-id</i> [ <i>.channel</i> ]
		aps keyword
		group-id 1 — 64
	ccag-id	<i>ccag-id.path-id</i> [ <i>cc-type</i> ]: <i>cc-id</i>
		ccag keyword
		id 1 — 8
		path-id a, b
		cc-type .sap-net, .net-sap
		cc-id 0 — 4094
	eth-tunnel	<i>eth-tunnel-id</i> [: <i>eth-tun-sap-id</i> ]
		id 1 — 1024
		eth-tun-sap-id 0 — 4094
	lag-id	lag-id
		lag keyword
		id 1 — 200
	qtag1	0 — 4094
	qtag2	*, 0 — 4094
	vpi	NNI: 0 — 4095
		UNI: 0 — 255
	vci	1, 2, 5 — 65535
	dldci	16 — 1022

## port

**Syntax** `port port-id`

**Description** This command specifies a port identifier.

**Parameters** *port-id* — The *port-id* can be configured in one of the following formats.

<b>Values</b>	port-id	
	slot/mda/port	[.channel]
	bundle-id	bundle-type-slot/mda.bundle-num
		bundle keyword
		type ima ppp
		bundle-num 1 — 256
	bpgrp-id	bpgrp-type-bpgrp-num
		bpgrp keyword
		type ima, ppp
		bpgrp-num 1 — 256
	aps-id	aps-group-id[.channel]
		aps keyword
		group-id 1 — 64
	ccag-id	ccag-id.<path-id>[cc-type]
		ccag keyword
		id 1 — 8
		path-id a, b
		cc-type [.sap-net .net-sap]
	lag-id	lag-id
		lag keyword
		id 1 — 200

# Standards and Protocol Support

---

## Standards Compliance

IEEE 802.1ab-REV/D3 Station and Media Access Control Connectivity Discovery  
IEEE 802.1d Bridging  
IEEE 802.1p/Q VLAN Tagging  
IEEE 802.1s Multiple Spanning Tree  
IEEE 802.1w Rapid Spanning Tree Protocol  
IEEE 802.1x Port Based Network Access Control  
IEEE 802.1ad Provider Bridges  
IEEE 802.1ah Provider Backbone Bridges  
IEEE 802.1ag Service Layer OAM  
IEEE 802.3ah Ethernet in the First Mile  
IEEE 802.1ak Multiple MAC Registration Protocol  
IEEE 802.3 10BaseT  
IEEE 802.3ad Link Aggregation  
IEEE 802.3ae 10Gbps Ethernet  
IEEE 802.3ah Ethernet OAM  
IEEE 802.3u 100BaseTX  
IEEE 802.3x Flow Control  
IEEE 802.3z 1000BaseSX/LX  
ITU-T Y.1731 OAM functions and mechanisms for Ethernet based networks  
draft-ietf-disman-alarm-mib-04.txt  
IANA-IFType-MIB  
IEEE8023-LAG-MIB

## ANCP/L2CP

draft-ietf-ancp-framework-01.txt  
draft-ietf-ancp-protocol-00.txt

## ATM

RFC 1626 Default IP MTU for use over ATM AAL5  
RFC 2514 Definitions of Textual Conventions and OBJECT\_IDENTITIES for ATM Management  
RFC 2515 Definition of Managed Objects for ATM Management RFC

2684 Multiprotocol Encapsulation over ATM Adaptation Layer 5  
AF-TM-0121.000 Traffic Management Specification Version 4.1  
ITU-T Recommendation I.610 - B-ISDN Operation and Maintenance Principles and Functions version 11/95  
ITU-T Recommendation I.432.1 ?BISDN user-network interface ?Physical layer specification: General characteristics  
GR-1248-CORE - Generic Requirements for Operations of ATM Network Elements (NEs). Issue 3  
GR-1113-CORE - Bellcore, Asynchronous Transfer Mode (ATM) and ATM Adaptation Layer (AAL) Protocols Generic Requirements, Issue 1  
AF-ILMI-0065.000 Integrated Local Management Interface (ILMI) Version 4.0  
AF-TM-0150.00 Addendum to Traffic Management v4.1 optional minimum desired cell rate indication for UBR  
AF-PHY-0086.001 Inverse Multiplexing for ATM (IMA) Specification Version 1.1

## BGP

RFC 1397 BGP Default Route Advertisement  
RFC 1772 Application of BGP in the Internet  
RFC 1965 Confederations for BGP  
RFC 1997 BGP Communities Attribute  
RFC 2385 Protection of BGP Sessions via MD5  
RFC 2439 BGP Route Flap Dampening  
RFC 2547bis BGP/MPLS VPNs  
draft-ietf-idr-rfc2858bis-09.txt.  
RFC 2918 Route Refresh Capability for BGP-4  
RFC 3107 Carrying Label Information in BGP-4

RFC 3392 Capabilities Advertisement with BGP4  
RFC 4271 BGP-4 (previously RFC 1771)  
RFC 4360 BGP Extended Communities Attribute  
RFC 4364 BGP/MPLS IP Virtual Private Networks (VPNs)(previously RFC 2547bis BGP/MPLS VPNs)  
RFC 4456 BGP Route Reflection: Alternative to Full-mesh IBGP (previously RFC 1966 & 2796)  
RFC 4724 Graceful Restart Mechanism for BGP ?GR helper  
RFC 4760 Multi-protocol Extensions for BGP  
RFC 4893 BGP Support for Four-octet AS Number Space  
RFC 5065 Confederations for BGP (obsoletes 3065)

## CIRCUIT EMULATION

RFC 4553 Structure-Agnostic Time Division Multiplexing (TDM) over Packet (SAToP)  
RFC 5086 Structure-Aware Time Division Multiplexed (TDM) Circuit Emulation Service over Packet Switched Network (CESoPSN)  
MEF-8 Implementation Agreement for the Emulation of PDH Circuits over Metro Ethernet Networks, October 2004  
RFC 5287 Control Protocol Extensions for the Setup of Time-Division Multiplexing (TDM) Pseudowires in MPLS Networks  
draft-ietf-pwe3-tdm-control-protocol-extensi-02.txt

## DHCP

RFC 2131 Dynamic Host Configuration Protocol (REV)  
RFC 3046 DHCP Relay Agent Information Option (Option 82)  
RFC 1534 Interoperation between DHCP and BOOTP

## Standards and Protocols

### DIFFERENTIATED SERVICES

RFC 2474 Definition of the DS Field the IPv4 and IPv6 Headers (Rev)  
RFC 2597 Assured Forwarding PHB Group (rev3260)  
RFC 2598 An Expedited Forwarding PHB  
RFC 3140 Per-Hop Behavior Identification Codes

### Frame Relay

FRF.1.2 - PVC User-to-Network Interface (UNI) Implementation Agreement  
FRF.5 - Frame Relay/ATM PVC Network Interworking Implementation  
ANSI T1.617 Annex D, DSS1 ?Signalling Specification For Frame Relay Bearer Service.  
FRF2.2 -PVC Network-to- Network Interface (NNI) Implementation Agreement.  
FRF.12 Frame Relay Fragmentation Implementation Agreement  
FRF.16.1 Multilink Frame Relay UNI/ NNI Implementation Agreement  
ITU-T Q.933 Annex A-Additional procedures for Permanent Virtual Connection (PVC) status management

### IPSec

RFC 2401 Security Architecture for the Internet Protocol  
RFC 3706 IKE Dead Peer Detection  
RFC 3947 Negotiation of NAT-Traversal in the IKE  
RFC 3948 UDP Encapsulation of IPsec ESP Packets  
draft-ietf-ipsec-isakmp-xauth

### IS-IS

RFC 1142 OSI IS-IS Intra-domain Routing Protocol (ISO 10589)  
RFC 1195 Use of OSI IS-IS for routing in TCP/IP & dual environments  
RFC 2763 Dynamic Hostname Exchange for IS-IS  
RFC 2966 Domain-wide Prefix Distribution with Two-Level IS-IS  
RFC 2973 IS-IS Mesh Groups  
RFC 3373 Three-Way Handshake for Intermediate System to Intermediate

System (IS-IS) Point-to-Point Adjacencies  
RFC 3567 Intermediate System to Intermediate System (ISIS) Cryptographic Authentication  
RFC 3719 Recommendations for Interoperable Networks using IS-IS  
RFC 3784 Intermediate System to Intermediate System (IS-IS) Extensions for Traffic Engineering (TE)  
RFC 3787 Recommendations for Interoperable IP Networks  
RFC 3847 Restart Signaling for IS-IS ?GR helper  
RFC 4205 for Shared Risk Link Group (SRLG) TLV  
draft-ietf-isis-igp-p2p-over-lan-05.txt  
draft-ietf-isis-wg-mib-05.txt

### IPv6

RFC 1981 Path MTU Discovery for IPv6  
RFC 2375 IPv6 Multicast Address Assignments  
RFC 2460 Internet Protocol, Version 6 (IPv6) Specification  
RFC 2461 Neighbor Discovery for IPv6  
RFC 2462 IPv6 Stateless Address Auto configuration  
RFC 2463 Internet Control Message Protocol (ICMPv6) for the Internet Protocol Version 6 Specification  
RFC 2464 Transmission of IPv6 Packets over Ethernet Networks  
RFC 2529 Transmission of IPv6 over IPv4 Domains without Explicit Tunnels  
RFC 2545 Use of BGP-4 Multiprotocol Extension for IPv6 Inter-Domain Routing  
RFC 2710 Multicast Listener Discovery (MLD) for IPv6  
RFC 2740 OSPF for IPv6  
RFC 3306 Unicast-Prefix-based IPv6 Multicast Addresses  
RFC 3315 Dynamic Host Configuration Protocol for IPv6  
RFC 3587 IPv6 Global Unicast Address Format  
RFC3590 Source Address Selection for the Multicast Listener Discovery (MLD) Protocol

RFC 3810 Multicast Listener Discovery Version 2 (MLDv2) for IPv6  
RFC 4007 IPv6 Scoped Address Architecture  
RFC 4193 Unique Local IPv6 Unicast Addresses  
RFC 4291 IPv6 Addressing Architecture  
RFC 4659 BGP-MPLS IP Virtual Private Network (VPN) Extension for IPv6 VPN  
RFC 5072 IP Version 6 over PPP  
draft-ietf-isis-ipv6-05  
draft-ietf-isis-wg-multi-topology-xx.txt

### LDP

RFC 3036 LDP Specification  
RFC 3037 LDP Applicability  
RFC 3478 Graceful Restart Mechanism for LDP ?GR helper  
RFC 5283 LDP extension for Inter-Area LSP  
draft-jork-ldp-igp-sync-03

### MPLS

RFC 3031 MPLS Architecture  
RFC 3032 MPLS Label Stack Encoding (REV3443))  
RFC 4379 Detecting Multi-Protocol Label Switched (MPLS) Data Plane Failures  
RFC 4182 Removing a Restriction on the use of MPLS Explicit NULL  
RFC 5332 MPLS Multicast Encapsulations  
draft-ietf-mpls-lsr-mib-06.txt  
draft-ietf-mpls-te-mib-04.txt  
draft-ietf-mpls-ldp-mib-07.txt

### Multicast

RFC 1112 Host Extensions for IP Multicasting (Snooping)  
RFC 2236 Internet Group Management Protocol, (Snooping)  
RFC 3376 Internet Group Management Protocol, Version 3 (Snooping)  
RFC 2362 Protocol Independent Multicast-Sparse Mode (PIMSM)  
RFC 3618 Multicast Source Discovery Protocol (MSDP)  
RFC 3446 Anycast Rendezvous Point (RP) mechanism using Protocol Independent Multicast (PIM) and

Multicast Source Discovery Protocol (MSDP)  
 RFC 4601 Protocol Independent Multicast - Sparse Mode (PIM-SM): Protocol Specification (Revised)  
 RFC 4604 Using IGMPv3 and MLDv2 for Source-Specific Multicast  
 RFC 4607 Source-Specific Multicast for IP  
 RFC 4608 Source-Specific Protocol Independent Multicast in 232/8  
 RFC 4610 Anycast-RP Using Protocol Independent Multicast (PIM)  
 draft-ietf-pim-sm-bsr-06.txt  
 draft-rosen-vpn-mcast-08.txt  
 draft-ietf-mboned-msdp-mib-01.txt  
 draft-ietf-l3vpn-2547bis-mcast-07: Multicast in MPLS/BGP IP VPNs  
 draft-ietf-l3vpn-2547bis-mcast-bgp-05: BGP Encodings and Procedures for Multicast in MPLS/BGP IP VPNs  
 RFC 3956: Embedding the Rendezvous Point (RP) Address in an IPv6 Multicast Address

#### NETWORK MANAGEMENT

ITU-T X.721: Information technology-OSI-Structure of Management Information  
 ITU-T X.734: Information technology-OSI-Systems Management: Event Report Management Function  
 M.3100/3120 Equipment and Connection Models  
 TMF 509/613 Network Connectivity Model  
 RFC 1157 SNMPv1  
 RFC 1215 A Convention for Defining Traps for use with the SNMP  
 RFC 1657 BGP4-MIB  
 RFC 1724 RIPv2-MIB  
 RFC 1850 OSPF-MIB  
 RFC 1907 SNMPv2-MIB  
 RFC 2011 IP-MIB  
 RFC 2012 TCP-MIB  
 RFC 2013 UDP-MIB  
 RFC 2096 IP-FORWARD-MIB  
 RFC 2138 RADIUS  
 RFC 2206 RSVP-MIB  
 RFC 2452 IPv6 Management Information Base for the Transmission Control Protocol

RFC 2454 IPv6 Management Information Base for the User Datagram Protocol  
 RFC 2465 Management Information Base for IPv6: Textual Conventions and General Group  
 RFC 2558 SONET-MIB  
 RFC 2571 SNMP-FRAMEWORKMIB  
 RFC 2572 SNMP-MPD-MIB  
 RFC 2573 SNMP-TARGET-&-NOTIFICATION-MIB  
 RFC 2574 SNMP-USER-BASED-SMMIB  
 RFC 2575 SNMP-VIEW-BASED-ACM-MIB  
 RFC 2576 SNMP-COMMUNITY-MIB  
 RFC 2665 EtherLike-MIB  
 RFC 2819 RMON-MIB  
 RFC 2863 IF-MIB  
 RFC 2864 INVERTED-STACK-MIB  
 RFC 2987 VRRP-MIB  
 RFC 3014 NOTIFICATION-LOGMIB  
 RFC 3019 IP Version 6 Management Information Base for The Multicast Listener Discovery Protocol  
 RFC 3164 Syslog  
 RFC 3273 HCRMON-MIB  
 RFC 3411 An Architecture for Describing Simple Network Management Protocol (SNMP) Management Frameworks  
 RFC 3412 - Message Processing and Dispatching for the Simple Network Management Protocol (SNMP)  
 RFC 3413 - Simple Network Management Protocol (SNMP) Applications  
 RFC 3414 - User-based Security Model (USM) for version 3 of the Simple Network Management Protocol (SNMPv3)  
 RFC 3418 - SNMP MIB

#### OSPF

RFC 1765 OSPF Database Overflow  
 RFC 2328 OSPF Version 2  
 RFC 2370 Opaque LSA Support  
 RFC 2740 OSPF for IPv6 (OSPFv3)  
 draft-ietf-ospf-ospfv3-update-14.txt  
 RFC 3101 OSPF NSSA Option  
 RFC 3137 OSPF Stub Router Advertisement  
 RFC 3623 Graceful OSPF Restart ?GR helper

RFC 3630 Traffic Engineering (TE) Extensions to OSPF Version 2  
 RFC 4203 for Shared Risk Link Group (SRLG) sub-TLV

#### PPP

RFC 1332 PPP IPCP  
 RFC 1377 PPP OSINLCP  
 RFC 1638/2878PPP BCP  
 RFC 1661 PPP (rev RFC2151)  
 RFC 1662 PPP in HDLC-like Framing  
 RFC 1877 PPP Internet Protocol Control Protocol Extensions for Name Server Addresses  
 RFC 1989 PPP Link Quality Monitoring  
 RFC 1990 The PPP Multilink Protocol (MP)  
 RFC 1994 "PPP Challenge Handshake Authentication Protocol (CHAP)  
 RFC 2516 A Method for Transmitting PPP Over Ethernet  
 RFC 2615 PPP over SONET/SDH  
 RFC 2686 The Multi-Class Extension to Multi-Link PPP

#### RIP

RFC 1058 RIP Version 1  
 RFC 2082 RIP-2 MD5 Authentication  
 RFC 2453 RIP Version 2

#### RSVP-TE

RFC 2430 A Provider Architecture DiffServ & TE  
 RFC 2702 Requirements for Traffic Engineering over MPLS  
 RFC2747 RSVP Cryptographic Authentication  
 RFC3097 RSVP Cryptographic Authentication  
 RFC 3209 Extensions to RSVP for Tunnels  
 RFC 3564 Requirements for Diff-Serv-aware TE  
 RFC 4090 Fast reroute Extensions to RSVP-TE for LSP Tunnels  
 RFC 4124 Protocol Extensions for Support of Diffserv-aware MPLS Traffic Engineering  
 RFC 4125 Maximum Allocation Bandwidth Constraints Model for Diffserv-aware MPLS Traffic Engineering

## Standards and Protocols

RFC 4875 Extensions to Resource Reservation Protocol - Traffic Engineering (RSVP-TE) for Point-to-Multipoint TE Label Switched Paths (LSPs)  
draft-ietf-mpls-soft-preemption-14 MPLS Traffic Engineering Soft Preemption  
draft-ietf-ccamp-mpls-graceful-shutdown-06 Graceful Shutdown in GMPLS Traffic Engineering Networks  
draft-ietf-mpls-p2mp-lsp-ping-06 Graceful Shutdown in GMPLS Traffic Engineering Networks

### PSEUDO-WIRE

RFC 3985 Pseudo Wire Emulation Edge-to-Edge (PWE3)  
RFC 4385 Pseudo Wire Emulation Edge-to-Edge (PWE3) Control Word for Use over an MPLS PSN  
RFC 3916 Requirements for Pseudo-Wire Emulation Edge-to-Edge (PWE3)  
RFC 4717 Encapsulation Methods for Transport ATM over MPLS Networks (draft-ietf-pwe3-atm-encap-10.txt)  
RFC 4816 PWE3 ATM Transparent Cell Transport Service (draft-ietf-pwe3-cell-transport-04.txt)  
RFC 4448 Encapsulation Methods for Transport of Ethernet over MPLS Networks (draft-ietf-pwe3-ethernet-encap-11.txt)  
RFC 4619 Encapsulation Methods for Transport of Frame Relay over MPLS Networks (draft-ietf-pwe3-frame-relay-07.txt)  
RFC 4446 IANA Allocations for PWE3  
RFC 4447 Pseudowire Setup and Maintenance Using LDP (draft-ietf-pwe3-control-protocol-17.txt)  
RFC 5085, Pseudowire Virtual Circuit Connectivity Verification (VCCV): A Control Channel for Pseudowires  
draft-ietf-l2vpn-vpws-iw-oam-02.txt  
draft-ietf-pwe3-oam-msg-map-05.txt  
draft-ietf-l2vpn-arp-mediation-04.txt  
draft-ietf-pwe3-ms-pw-arch-05.txt  
draft-ietf-pwe3-segmented-pw-11.txt

draft-hart-pwe3-segmented-pw-vcv-02.txt  
draft-muley-dutta-pwe3-redundancy-bit-02.txt  
draft-muley-pwe3-redundancy-02.txt  
MFA Forum 9.0.0 The Use of Virtual trunks for ATM/MPLS Control Plane Interworking  
MFA Forum 12.0.0 Multiservice Interworking - Ethernet over MPLS  
MFA forum 13.0.0 - Fault Management for Multiservice Interworking v1.0  
MFA Forum 16.0.0 ?Multiservice Interworking - IP over MPLS

### RADIUS

RFC 2865 Remote Authentication Dial In User Service  
RFC 2866 RADIUS Accounting

### SONET/SDH

GR-253-CORE SONET Transport Systems: Common Generic Criteria. Issue 3, September 2000  
ITU-G.841 Telecommunication Standardization Section of ITU, Types and Characteristics of SDH Networks Protection Architecture, issued in October 1998 and as augmented by Corrigendum1 issued in July 2002  
GR-253-CORE - SONET Transport Systems: Common Generic Criteria. Issue 3, September 2000

### SSH

draft-ietf-secsh-architecture.txt SSH Protocol Architecture  
draft-ietf-secsh-userauth.txt SSH Authentication Protocol  
draft-ietf-secsh-transport.txt SSH Transport Layer Protocol  
draft-ietf-secsh-connection.txt SSH Connection Protocol  
draft-ietf-secsh- newmodes.txt SSH Transport Layer Encryption Modes

### TACACS+

draft-grant-tacacs-02.txt

### TCP/IP

RFC 768 UDP  
RFC 1350 The TFTP Protocol (Rev.

RFC 791 IP  
RFC 792 ICMP  
RFC 793 TCP  
RFC 826 ARP  
RFC 854 Telnet  
RFC 951 BootP (rev)  
RFC 1519 CIDR  
RFC 1542 Clarifications and Extensions for the Bootstrap Protocol  
RFC 1812 Requirements for IPv4 Routers  
RFC 2347 TFTP option Extension  
RFC 2328 TFTP Blocksize Option  
RFC 2349 TFTP Timeout Interval and Transfer Size option  
RFC 2401 Security Architecture for Internet Protocol  
draft-ietf-bfd-mib-00.txt Bidirectional Forwarding Detection Management Information Base  
draft-ietf-bfd-base-05.txt Bidirectional Forwarding Detection  
draft-ietf-bfd-v4v6-1hop-06.txt BFD IPv4 and IPv6 (Single Hop)  
draft-ietf-bfd-multihop-06.txt BFD for Multihop Paths

### VPLS

RFC 4762 Virtual Private LAN Services Using LDP (previously draft-ietf-l2vpn-vpls-ldp-08.txt)  
draft-ietf-l2vpn-vpls-mcast-reqts-04.txt

### VRRP

RFC 2787 Definitions of Managed Objects for the Virtual Router Redundancy Protocol  
RFC 3768 Virtual Router Redundancy Protocol  
draft-ietf-vrrp-unified-spec-02: Virtual Router Redundancy Protocol Version 3 for IPv4 and IPv6

### Proprietary MIBs

TIMETRA-APS-MIB.mib  
TIMETRA-ATM-MIB.mib  
TIMETRA-BGP-MIB.mib  
TIMETRA-CAPABILITY-7750-V4v0.mib  
TIMETRA-CFLOWD-MIB.mib  
TIMETRA-CHASSIS-MIB.mib  
TIMETRA-CLEAR-MIB.mib  
TIMETRA-FILTER-MIB.mib

TIMETRA-GLOBAL-MIB.mib  
TIMETRA-IGMP-MIB.mib  
TIMETRA-ISIS-MIB.mib  
TIMETRA-LAG-MIB.mib  
TIMETRA-LDP-MIB.mib  
TIMETRA-LOG-MIB.mib  
TIMETRA-MIRROR-MIB.mib  
TIMETRA-MPLS-MIB.mib  
TIMETRA-NG-BGP-MIB.mib  
TIMETRA-OAM-TEST-MIB.mib  
TIMETRA-OSPF-MIB.mib  
TIMETRA-OSPF-V3-MIB.mib  
TIMETRA-PIM-MIB.mib  
TIMETRA-PORT-MIB.mib  
TIMETRA-PPP-MIB.mib  
TIMETRA-QOS-MIB.mib  
TIMETRA-RIP-MIB.mib  
TIMETRA-ROUTE-POLICY-MIB.mib  
TIMETRA-RSVP-MIB.mib  
TIMETRA-SECURITY-MIB.mib  
TIMETRA-SERV-MIB.mib  
TIMETRA-SUBSCRIBER-MGMTMIB.  
mib  
TIMETRA-SYSTEM-MIB.mib  
TIMETRA-TC-MIB.mib  
TIMETRA-VRRP-MIB.mib  
TIMETRA-VRTR-MIB.mib



# Index

## C

continuity check 156  
CPE ping 132

## E

Ethernet CFM 147

## I

IGMP snooping diagnostics 142

## L

lawful intercept 30  
    configuration 40  
    logging 45  
LDP  
    ECMP 145  
linktrace 154  
loopback 153  
LSP diagnostics 122

## M

MAC ping 131  
MAC populate 133  
MAC purge 133  
MAC trace 131  
MFIB ping 142  
Mirror  
    overview 18  
        implementation 20  
        local and remote 21  
        slicing 21  
        source and destination 20  
    configuring  
        basic 46  
        classification rules 48  
            ingress label 50  
            IP filter 50  
            MAC filter 50  
        port 48  
        SAP 49

command reference 71  
local mirror service 53  
management tasks 64  
overview 38  
remote mirror service 57  
SDPs 55

## O

OAM 122  
    overview 122  
    configuring  
        command reference 175

## P

periodic path exercising 146  
ping  
    MFIB 142  
    VCCV 134

## S

SAA test parameters 171  
SDP diagnostics 129  
SDP ping 129  
service assurance agent 168  
service diagnostics 130

## T

Tools 281

## V

VCCV ping 134  
VCCV trace 137  
VLL diagnostics 134  
VPLS MAC diagnostics 130

Index