



# 7210 SERVICE ACCESS SWITCH (SAS) ETHERNET INSTALLATION GUIDE

November 2013

Document Part Number: 93-0245-01-13



Copyright 2013 Alcatel-Lucent All rights reserved.

No portion of this document may be reproduced in any form or means without prior written permission from Alcatel-Lucent. Information in this document is proprietary and confidential to Alcatel. The information in this document is subject to change. All trademarks and registered trademarks are the property of the respective owners.

### **USA Requirements Only**

Federal Communications Commission (FCC) Compliance Notice: Radio Frequency Notice

Note: This equipment has been tested and found to comply with the limits for a Class A digital device, pursuant to part 15 of the FCC Rules. These limits are designed to provide reasonable protection against harmful interference when the equipment is operated in a commercial environment. This equipment generates, uses, and can radiate radio frequency energy and, if not installed and used in accordance with the instruction manual, may cause harmful interference to radio communications. Operation of this equipment in a residential area is likely to cause harmful interference in which case the user will be required to correct the interference at his own expense.

### **Canadian Requirements Only**

This Class A digital apparatus meets all requirements of the Canadian Interference-Causing Equipment Regulations.

Cet appareil numérique de la classe A respecte toutes les exigences du Règlement sur le matériel brouilleur du Canada.

### **Japan/Nippon Requirements Only**

This is a Class A product. In a domestic environment this product may cause radio interference in which case the user may be required to take adequate measures.

この装置は、クラスA情報技術装置です。この装置を家庭環境で使用すると電波妨害を引き起こすことがあります。この場合には使用者が適切な対策を講ずるよう要求されることがあります。

VCCI-A



**Caution:**

Use of controls or adjustments or performance of procedures other than those specified herein may result in hazardous laser radiation exposure.

# TABLE OF CONTENTS

<b>Preface</b> .....	9
<b>7210 SAS-E Overview</b>	
Switch Features .....	12
Switch Architecture .....	13
Network Management Options .....	13
Features .....	14
Connectivity .....	14
Hardware Description .....	15
Ethernet Interfaces .....	16
Management Port .....	16
Console Port .....	16
Alarm Interface Port .....	17
Power Modules .....	19
DC power source failure detection .....	21
USB Port .....	24
Fan Tray .....	24
System LEDs and Buttons .....	26
System and Port LEDs .....	27
Port LEDs .....	27
System Buttons and Switches .....	28
<b>Installing the 7210 SAS-E</b>	
Site Preparation .....	32
Selecting a Site .....	32
Ethernet Cabling .....	32
Equipment Checklist .....	33
Installing Your Switch .....	34
Rack Mounting .....	34
Desktop or Shelf Mounting .....	36
Grounding the Chassis .....	37
Connecting to a Power Source .....	38
Connecting to AC Power .....	38
Connecting to DC Power .....	39
Connecting to the Console Port .....	41
Warnings and Notes .....	44
Installation Preparation .....	45
Locking Mechanisms .....	45
Installing SFPs .....	46
Removing SFPs .....	46
<b>Configuring the 7210 SAS-E</b>	
Diagnostics .....	48
Post Installation Status .....	48
Initializing the System and Downloading Software .....	49

## Table of Contents

Booting a 7210 SAS-E in the Lab . . . . .	49
Booting a 7210 SAS-E using the image on Flash (with the image shipped by factory) . . . . .	50
Booting a 7210 SAS-E From the Network . . . . .	53
Using the Out-of-Band Ethernet Management port to boot 7210 from the network . . . . .	60
Downloading the TiMOS software to the internal flash. . . . .	62
Establishing Router Connections . . . . .	66
Console Connection . . . . .	66
Telnet Connection . . . . .	67
Running Telnet . . . . .	68
Restarting the Router . . . . .	69
<b>Troubleshooting</b>	
Diagnosing Switch Indicators . . . . .	72
Power and Cooling Problems . . . . .	73
Installation . . . . .	74
In-Band Access. . . . .	75
<b>Appendix A: Specifications</b>	
Specifications . . . . .	78
Japan VCCI Class A Declaration. . . . .	79
RoHS and WEEE. . . . .	79
<b>Appendix B: Pin Assignments</b>	
Management Port Pin Assignments . . . . .	82
Console Port Pin Assignment. . . . .	83
<b>Appendix C: Alarm Pin Assignments</b>	
Alarm Port Pin Assignments . . . . .	86

# LIST OF TABLES

## Preface

Table 1: Information Symbols .....	10
------------------------------------	----

## 7210 SAS-E Overview

Table 2: 7210 SAS-E Front Panel Features .....	15
Table 3: Alarm Interface Port Pinouts .....	17
Table 4: Power Module LEDs .....	19
Table 5: Power Source Failure Detection Capability .....	22
Table 6: 7210 SAS-E System LEDs and Buttons .....	26
Table 7: System and Port Status LEDs .....	27
Table 8: 100/1000 Fiber-Optic SFP and 10/100/1000Base-T Copper Port LEDs .....	27
Table 9: Port LED Key Descriptions .....	28
Table 10: Front Panel Buttons and Switches .....	28

## Installing the 7210 SAS-E

Table 11: Serial Cable Wiring .....	41
-------------------------------------	----

## Configuring the 7210 SAS-E

Table 12: Console Configuration Parameter Values .....	66
--	----

## Troubleshooting

Table 13: Troubleshooting .....	72
---------------------------------	----

## Appendix A: Specifications

Table 14: 7210 SAS-E Specifications .....	78
---	----

## Appendix B: Pin Assignments

Table 15: 10/100BASE-TX MDI and MDI-X Port Pinouts .....	82
Table 16: Serial Cable Wiring .....	83

## Appendix C: Alarm Pin Assignments

Table 17: Alarm Interface Port Pinouts .....	86
--	----

## List of Tables

# LIST OF FIGURES

## **7210 SAS-E Overview**

Figure 1:	7210 SAS-E Front Panel.....	12
Figure 2:	7210 SAS E Front Panel.....	15
Figure 3:	AC and DC Power Modules.....	19
Figure 4:	Fan Tray.....	24
Figure 5:	Removing and Replacing the Fan Tray and Air Filter.....	25
Figure 6:	System LEDs and Buttons.....	26
Figure 7:	SFP Port LEDs.....	28

## **Installing the 7210 SAS-E**

Figure 8:	Attaching the Brackets.....	34
Figure 9:	Installing the Switch in a Rack.....	35
Figure 10:	Attaching the Adhesive Feet.....	36
Figure 11:	Connecting to a -48 VDC Power Source.....	40
Figure 12:	Connecting to a +24 VDC Power Source.....	40

## **Configuring the 7210 SAS-E**

Figure 13:	7210 SAS-E Boot Process.....	49
------------	------------------------------	----

## **Troubleshooting**

### **Appendix A: Specifications**

### **Appendix B: Pin Assignments**

### **Appendix C: Alarm Pin Assignments**

Figure 14:	DB-15 Alarm Connector.....	86
Figure 15:	Alarm Input Connection Diagram.....	88

## List of Figures



## About This Manual

This guide provides site preparation recommendations, step-by-step procedures to rack mount the Alcatel-Lucent 7210 Service Access Switch (SAS-E)<sup>®</sup>, and instructions to install and configure the TiMOS software.

Each 7210 SAS-E router is shipped with rack-mounting brackets, a console cable, power cord (AC or DC), and rubber feet.

---

## Warnings and Notes

Observe the warnings and notes to avoid injury or router damage during installation and maintenance. Follow the safety procedures and guidelines when working with and near electrical equipment. Warning statements and notes are provided in each chapter.

---





## Audience

This guide is intended for network installers and system administrators who are responsible for installing, configuring, or maintaining networks. This guide assumes you are familiar with electronic and networking technologies.

## Information Symbols

Table 1 describes symbols contained in this guide.

**Table 1: Information Symbols**

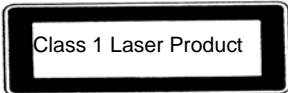
Symbol	Meaning	Description
	Danger	This symbol warns that improper handling and installation could result in bodily injury. An electric shock hazard could exist. Before you begin work on this equipment, be aware of hazards involving electrical circuitry, networking environments, and instigate accident prevention procedures.
	Caution	This symbol warns that improper handling and installation could result in equipment damage or loss of data.
	Warning	This symbol warns that improper handling may reduce your component or system performance.
	Note	This symbol provides additional operational information.
		Class 1 laser products are listed in the MDA installation guides. Only approved Class 1 replaceable laser transceivers should be used with this product.

## Technical Support

If you purchased a service agreement for your 7210 SAS-E and related products from a distributor or authorized reseller, contact the technical support staff for that distributor or reseller for assistance. If you purchased an Alcatel-Lucent service agreement, contact technical assistance at:

Web: [http://www1.alcatel-lucent.com/comps/pages/carrier\\_support.jhtml](http://www1.alcatel-lucent.com/comps/pages/carrier_support.jhtml)

# 7210 SAS-E Overview

---

This chapter describes the 7210 SAS-E features and includes the following sections:

- ["Switch Features" on page 12](#)
- ["Switch Architecture" on page 13](#)
- ["Features" on page 14](#)
- ["Hardware Description" on page 15](#)

## Switch Features

The 7210 SAS-E is a multilayer service-aware Layer 2 switch. It supports up to 24 connections including 12 100/1000 fiber-optic SFP ports and 12 10/100/1000Base-T copper SFP ports.

The 7210 SAS-E has one 10/100BASE-TX management port for dedicated management access.

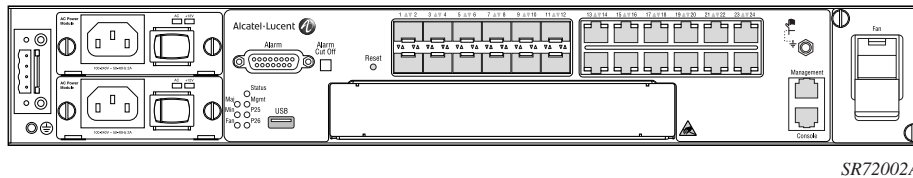

**Figure 1: 7210 SAS-E Front Panel**

The 7210 SAS-E includes the following features:

- 12 100/1000 fiber-optic SFP ports and 12 10/100/1000Base-T copper SFP ports
- One RJ-45 management port for firmware upgrade or system management
- One RJ-45 console (RS-232 interface) connector for device management
- Embedded SR OS
- Compact size: 1.5RU height, 19-inch rack-mountable metal enclosure, 10-inch depth (ETSI)

## Switch Architecture

The 7210 SAS-E employs a wire-speed, non-blocking switching fabric. This permits simultaneous wire-speed transport of multiple packets at low latency on all ports. The switch also features full-duplex capability on all ports, that effectively doubles the bandwidth of each connection.

---

## Network Management Options

This switch contains a comprehensive array of LEDs for at-a-glance monitoring of network and port status. It also includes a management agent that enables you to configure or monitor your switch using its CLI, or by using SNMP applications.

To manage the switch, you can make a direct connection to the console port (out-of-band) or you can manage it by using a network connection (in-band) using Telnet/SSH or SNMP-based network management software.

The management port provides a dedicated management channel that operates outside of the data transport network. This makes it possible to reconfigure or troubleshoot the switch over either a local or remote connection to the management port when access using the data channel is not possible or deemed insecure.

## Features

The 7210 SAS-E includes the following features:

- Wire speed, non-blocking, service-aware Ethernet switch
  - 12 100/1000 fiber-optic SFP ports and 12 10/100/1000Base-T copper SFP ports
  - Powered by SR OS for feature-rich Carrier Ethernet VPN services
  - Per-service quality of service (QoS) with up to eight levels of class-based queuing per port
  - Per-service OAM toolkit with IEEE 802.1ag, IEEE 802.3ah and local service mirroring
  - Ethernet features include IEEE 802.1Q and QinQ (stacked VLAN IDs)
  - Dual homed connections uplinks to separate aggregation devices
  - Flexible deployment options with support for mesh and ring topologies
  - MEF 9 and MEF 14 certified platform
  - Managed by the 5620 SAM
  - Provides four isolated alarm inputs and two dry contacts that relay outputs through a DB-15 interface on the front panel
  - Hot-swappable, redundant, load sharing AC or DC power and fan modules
- 

## Connectivity

The 7210 SAS-E includes the following connectivity features:

- 100/1000 fiber-optic SFP ports and 10/100/1000Base-T copper SFP ports full-duplex connections.
- Auto-negotiation enables each port to automatically select the optimum speed and communication mode (half or full duplex) if this feature is supported by the attached device.
- IEEE 802.3-2005 Ethernet, Fast Ethernet and Gigabit Ethernet compliance ensures compatibility with standards-based network cards and switches from any vendor.

## Hardware Description

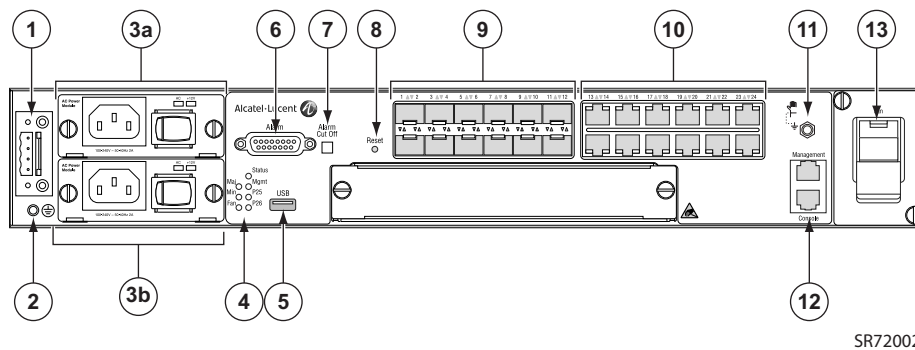

**Figure 2: 7210 SAS E Front Panel**

**Table 2: 7210 SAS-E Front Panel Features**

Key	Description
1	Ground and DC power connection
2	Additional chassis ground point <sup>a</sup>
3	Power trays Power tray one to fit power supply 3a Power tray two to fit power supply 3b
4	LEDs
5	USB port
6	Alarm connector
7	Alarm cut off button
8	Reset button
9	100/1000 fiber-optic SFP ports
10	10/100/1000Base-T copper SFP ports

**Table 2: 7210 SAS-E Front Panel Features**

Key	Description
11	Wrist strap grounding point
12	Management (top) and console (bottom) ports
13	Fan tray

a. The primary ground point is on the rear of the chassis.

## Ethernet Interfaces

The 7210 SAS-E provides 12 100/1000 fiber-optic SFP ports. Each fiber-optic port can be used for a direct connection to a subscriber's Customer Premises Equipment (CPE), or as an uplink to another aggregation node. The 7210 SAS-E also provides 12 10/100/1000Base-T copper SFP ports.

---

## Management Port

The management port provides a dedicated management interface that is segregated from data traffic crossing the other ports.

---

## Console Port

The console port uses an RJ-45 connector with serial pinouts (see [Table 11](#)) that enables a connection to a terminal for performing switch monitoring and configuration operations. The terminal may be a PC or workstation that is running terminal emulation software, or a terminal configured as a Data Terminal Equipment (DTE) connection. A null-modem wired serial cable is supplied with the switch for connecting to this interface.

The serial port configuration requirements are as follows:

- Default Baud rate – 115200 bps
- Character Size – 8 Characters
- Parity – None
- Stop bit – One
- Data bits – 8
- Flow control – none



## Alarm Interface Port

The alarm interface port is a D-type 15-pin connector that supports a critical alarm output, a major alarm output, and four alarm inputs. When your system has a critical or major alarm, the CPU will drive the alarm relay to issue the alarm output and turn on the critical or major LED. If you push the alarm cut off (ACO) button, the relay will be released but the LED will stay on until the alarm is cleared.

The system signals the appropriate alarm output for the following events:

- Fan failure - Critical alarm is raised.
- On power supply failure - Critical alarm is raised. The critical alarm is cleared and a major alarm is raised if the failed power supply is removed).
- On power source failure - Critical alarm is generated and the system's status LED turns amber in color and blinks.
- Chassis temperature threshold exceeded - Major alarm is raised.

The system also supports four alarm inputs. The input voltage range is from 24V to 48V. If an alarm input is active, the CPU will process it, output it to the CLI, and issue an SNMP trap. An alarm input can also be configured to drive the appropriate alarm output pin. Please refer the System Basics user guide for more details on configuring the alarm inputs.

See [Table 3](#) for the alarm interface port pinouts.

**Table 3: Alarm Interface Port Pinouts**

Pin	Name	Function
1	CRIT_ALARM_CNTR	Common contact for critical alarm relay
2	CRIT_ALARM_NO	Normally open during critical alarm state
3	MJR_ALARM_NC	Normally closed during major alarm state
4	No Contact	
5	ALARM_IN4_EXT_P	External alarm input 4 (the positive side of the alarm input)
6	ALARM_IN3_EXT_P	External alarm input 3 (external relay dry contact closure to pin 13)
7	ALARM_IN2_EXT_P	External alarm input 2 (external relay dry contact closure to pin 14)

**Table 3: Alarm Interface Port Pinouts**

<b>Pin</b>	<b>Name</b>	<b>Function</b>
8	ALARM_IN1_EXT_P	External alarm input 1 (external relay dry contact closure to pin 15)
9	CRIT_ALARM_NC	Normally closed during critical alarm state
10	MJR_ALARM_CNTR	Common contact for major alarm relay
11	MJR_ALARM_NO	Normally open during major alarm state
12	ALARM_IN4_EXT_RTN	External alarm input 4 (the negative side of the alarm input)
13	ALARM_IN3_EXT_RTN	External alarm input 3 (external relay dry contact closure from pin 6)
14	ALARM_IN2_EXT_RTN	External alarm input 2 (external relay dry contact closure from pin 7)
15	ALARM_IN1_EXT_RTN	External alarm input 1 (external relay dry contact closure from pin 8)

## Power Modules

7210 SAS-E 24F variant provides three power module options: -48V, +24V and universal AC. See [Figure 3](#) for an illustration of the power modules.

For specifications on the power supply modules and external input power requirements, see [Appendix A, Specifications](#), on page 77.

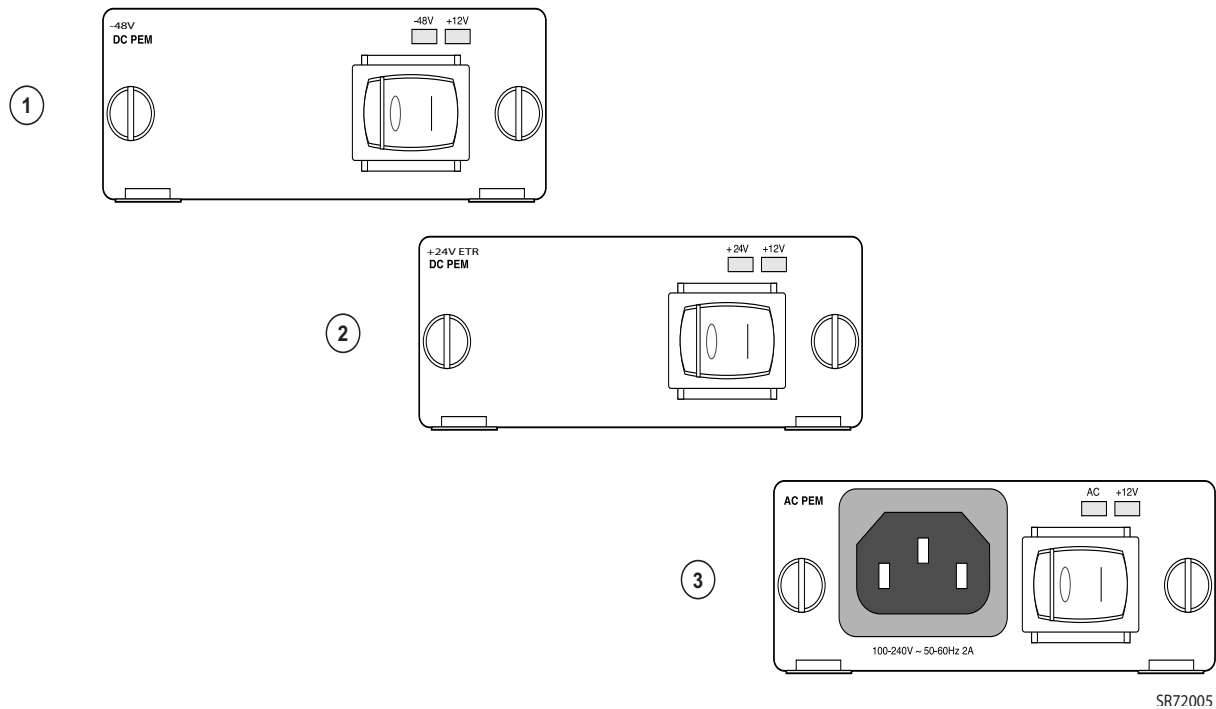

**Figure 3: AC and DC Power Modules**

**Table 4: Power Module LEDs**

LED	Condition	Status
AC, -48V,+24, +12V	Green	DC or AC power is functioning normally.
	Off	External power not connected or has failed.

## Hardware Description

The -48V/+24V/AC LEDs on the left indicate the status of external power. The +12V LED on the right indicates the status of the internal power conversion process.



**Note:** You must use AC and/or DC power supplies with your 7210 SAS-E. AC and DC power supplies can be used simultaneously.

---



**Note:** The +24V DC power module must not be used simultaneously with the -48V DC power supply.

---

## DC power source failure detection

The 7210 platform provides capability to detect DC power source (-48V or +24V source) failure. The 7210 chassis allows two DC power sources to be connected to the chassis. If the system detects that a DC power source has failed, it raises a critical alarm (the Critical LED is lit and the Critical Alarm output pin is triggered) and the system's status LED turns amber and blinks.. The alarm is cleared if the DC power source is restored. There is no user configuration required to enable this feature. The software enables this feature automatically by detecting the capability of the hardware platform.

The system has two slots to plug in AC or DC power supplies. It associates the DC power supply in top slot with power source feed #A (-48V or +24V Ret-A on the chassis) and DC power supply in the bottom slot with power source feed #B (-48V or +24V RetB on the chassis). The system detects the failure of power source feed #A only if the DC power supply is plugged into the top slot. Similarly, the system detects the failure of power source feed #B only if the DC power supply is plugged into the bottom slot. The trap message generated by the system indicates that there was an input failure for the power supply associated with power input feed that failed.



**Note:** New traps needs to be explicitly enabled by the user and are suppressed by default.

---



**Notes:** The power feeds are summed up internally before feeding the power supply units. Hence, the DC power supply units will output power even if one of the power source feed is available.

---



**Note:** Please check the release notes to know the software release that supports this feature.

---

The following table lists the conditions under which the system detects a power source failure.

**Table 5: Power Source Failure Detection Capability**

<b>Power Feed #A (Available/ Failed)</b>	<b>Power Feed #B (Available/ Failed)</b>	<b>Power Supply in Top Slot (PS1)</b>	<b>Power Supply in Bottom Slot (PS2)</b>	<b>Alarm Generated (Yes/No)</b>	<b>Notes</b>
Available	Available	DC	DC	No	
Available	Failed	DC	DC	Yes	PS2 input failure / PS2 output OK
Failed	Available	DC	DC	Yes	PS1 input failure / PS1 output OK
Failed	Failed	DC	DC		No power to system
Available	Available	None	DC	No	
Available	Failed	None	DC	Yes	PS2 input failure / PS2 output OK
Failed	Available	None	DC	No	Input failure / Not detected
Failed	Failed	None	DC		No power to system
Available	Available	DC	None	No	
Available	Failed	DC	None	No	Input failure / Not detected
Failed	Available	DC	None	Yes	PS1 input failure / PS1 output OK
Failed	Failed	DC	None		No power to system
Available	Available	AC	DC	No	
Available	Failed	AC	DC	Yes	PS2 input failure / PS2 output OK
Failed	Available	AC	DC	No	Input failure / Not detected
Failed	Failed	AC	DC	Yes	PS2 input failure / PS2 output failure
Available	Available	DC	AC	No	

**Table 5: Power Source Failure Detection Capability**

<b>Power Feed #A (Available/ Failed)</b>	<b>Power Feed #B (Available/ Failed)</b>	<b>Power Supply in Top Slot (PS1)</b>	<b>Power Supply in Bottom Slot (PS2)</b>	<b>Alarm Generated (Yes/No)</b>	<b>Notes</b>
Available	Failed	DC	AC	No	Input failure / Not detected
Failed	Available	DC	AC	Yes	PS1 input failure / PS1 output OK
Failed	Failed	DC	AC	Yes	PS1 input failure / PS1 output OK

## USB Port

The USB port is reserved for future use.

---

## Fan Tray

A hot-swappable fan tray on the right side of the front panel contains three fans that provide cooling for the chassis. See [Figure 4](#) for an illustration of the fan tray.

The fans are controlled by the system software, and their speed is set according to the environmental temperature surrounding the switch. Allow at least three inches of clearance on the side of the rack to ensure proper airflow intake cooling system. The fan trays must be in place before the chassis is powered on.

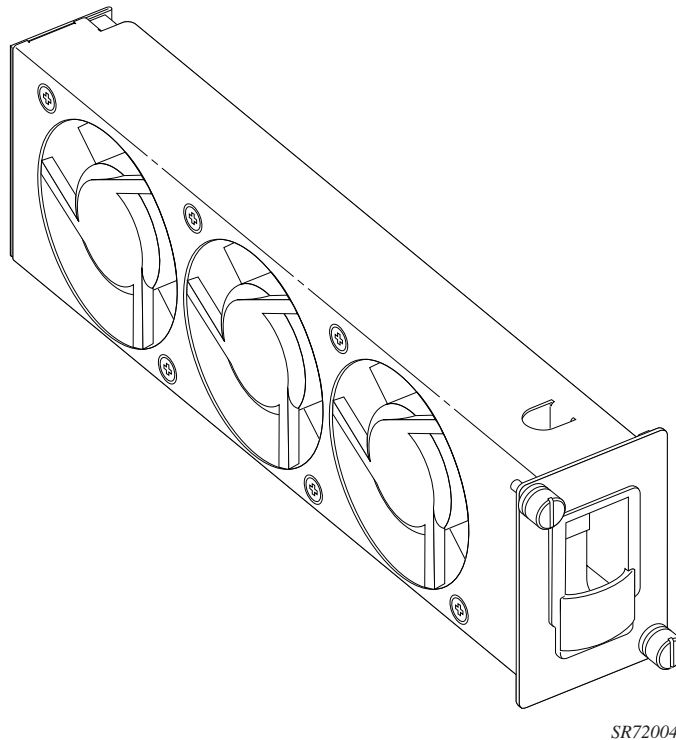

**Figure 4: Fan Tray**



The fan tray also contains an air filter. The filter tray must always be installed while the chassis is powered up. The air filter prevents large particles, debris, and dust from entering and circulating through the system. Inspect your air filter monthly and clean it when accumulated dust is present.

To inspect and remove your air filter, see [Figure 5](#) and perform the following steps:

- Step 1** Loosen the captive screws on the fan tray (1).
- Step 2** Carefully remove the fan tray from the router chassis and remove the air filter (2) to inspect it and clean it if necessary.
- Step 3** After inspecting and cleaning the air filter, replace it in the fan tray so that the edge of the air filter is flush with the rear of the fan tray.
- Step 4** Replace the fan tray and tighten the captive screws.

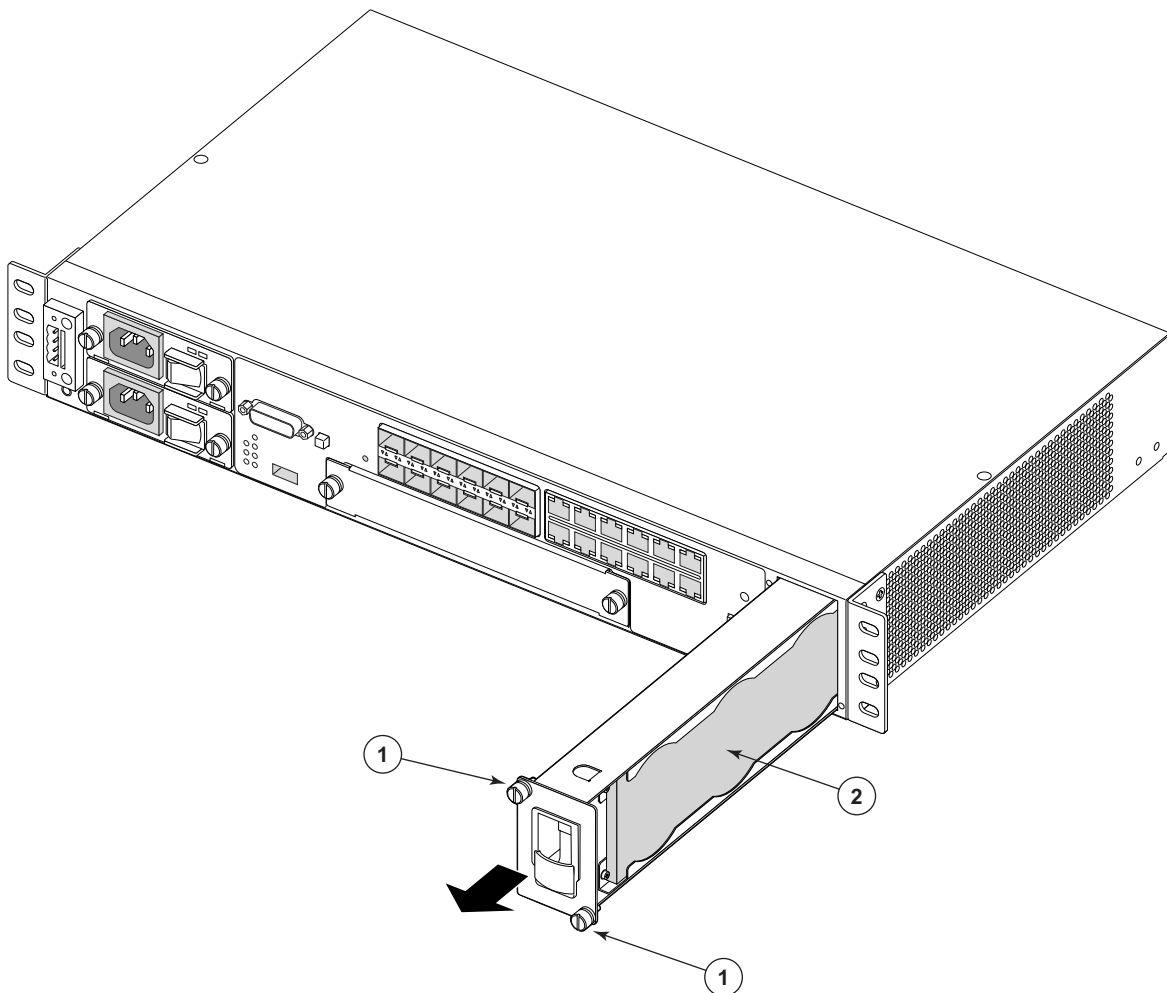

**Figure 5: Removing and Replacing the Fan Tray and Air Filter**

## System LEDs and Buttons

The LEDs are located on the front panel and the power module trays. See [Figure 6](#) for the location of the system LEDs and buttons, [Table 6](#) for key descriptions, and [Table 7](#) for alarm descriptions.

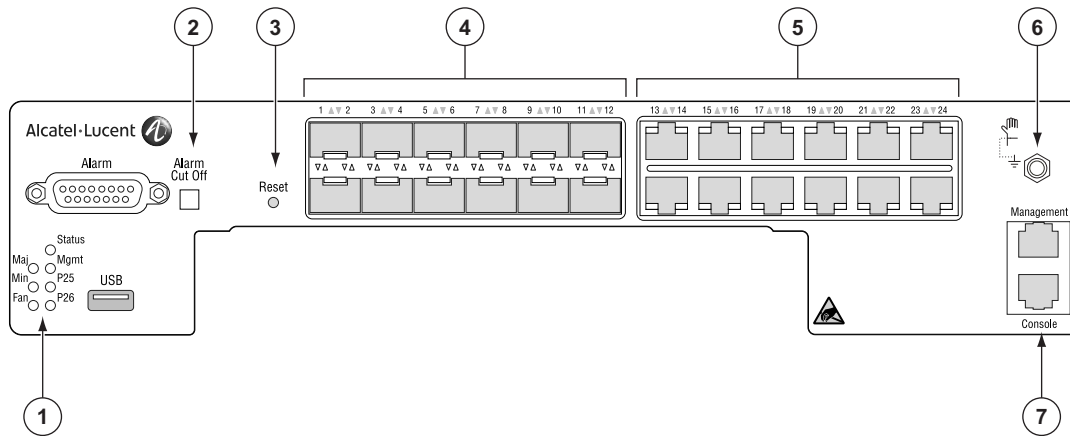

**Figure 6: System LEDs and Buttons**

**Table 6: 7210 SAS-E System LEDs and Buttons**

Key	Description
1	Alarm LEDs
2	Alarm Cut Off button
3	Reset button
4	100/1000 fiber-optic SFP port LEDs
5	10/100/1000Base-T copper SFP port LEDs
6	Wrist strap grounding point
7	Console connectors

## System and Port LEDs

**Table 7: System and Port Status LEDs**

LED	Condition	Status
Critical	Red	Indicates the presence of a new critical alarm.
Major	Amber	Indicates the presence of a new major alarm.
Fan	Off	Indicates that the fans are functioning properly.
	Red	Indicates that one or more of the fans has failed, or that the fan tray is not connected. <b>Note:</b> The LED blinks shortly during the boot process.
Status	Green	The system has completed boot phase and is running normally. <b>Note:</b> The status LED turns amber and blinks on power source failure.

## Port LEDs

The 12 100/1000 fiber-optic SFP ports and 12 10/100/1000Base-T copper SFP ports are separated into two sections of 12 ports each.

The odd numbered ports are in the top row, and the even numbered ports are in the bottom row.

**Table 8: 100/1000 Fiber-Optic SFP and 10/100/1000Base-T Copper Port LEDs**

LED	Condition	Status
1/1/1 – 1/1/12 – SFP ports and 1/1/13 – 1/1/24 – Fixed Copper ports	Green	Port has a valid link.
	Flashing Green	Flashing indicates activity on the port.
	Off	The link is down.

See [Figure 7](#) for an illustration of two ports and their corresponding LEDs. See [Table 10](#) key descriptions.

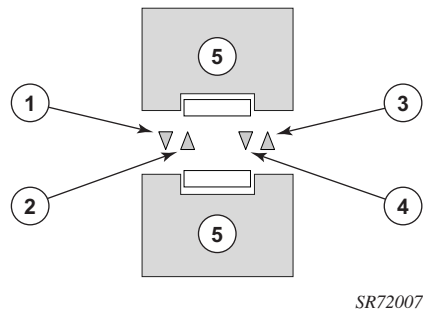

**Figure 7: SFP Port LEDs**

**Table 9: Port LED Key Descriptions**

Key	Description
1	Reserved.
2	LED that indicates status for an odd-numbered port. Odd-numbered ports are in the top row.
3	Reserved.
4	LED that indicates status for an even numbered port. Even-numbered ports are in the bottom row.
5	SFP slots.

## System Buttons and Switches

See [Table 10](#) for descriptions of front panel buttons and switches.

**Table 10: Front Panel Buttons and Switches**

Button/Switch	Condition	Status
Power Module Switch	0	Standby mode if switch is connected to a power source.
	1	AC or DC power is applied to the switch.
ACO (Alarm Cut Off)	Not pushed	Normal operating mode.

**Table 10: Front Panel Buttons and Switches**

<b>Button/Switch</b>	<b>Condition</b>	<b>Status</b>
Reset (Recessed)	Not pushed	Normal operating mode. To reset hardware, follow reset procedure mentioned in " <a href="#">Restarting the Router</a> " on <a href="#">page 69</a> .



# Installing the 7210 SAS-E

---

This chapter describes site preparation and installation of your 7210 SAS-E and includes the following sections:

- ["Site Preparation" on page 32](#)
- ["Installing Your Switch" on page 34](#)

## Site Preparation

---

### Selecting a Site

You can mount the 7210 SAS-E in a standard 19-inch equipment rack or on a flat surface. When mounting on a flat surface, ensure that the four rubber feet are installed on the bottom of the box.

The site should be a weather-protected and temperature-controlled location, and should include the following criteria:

- Maintain site temperature within 0 to 50 °C (32 to 122 °F) and its humidity within 5% to 95%, non-condensing.
- Provide adequate space on the front and two sides of the unit to enable servicing and proper air flow.
- Ensure a secure environment in which only authorized and trained service personnel are allowed to service the unit (IEC 60950 safety requirement).

---

### Ethernet Cabling

To ensure proper operation when installing switches into a network, make sure that the cables are suitable for 100/1000 fiber-optic or 10/100/1000Base-T copper operation, as appropriate. Make sure your installation complies with the following guidelines:

- Cable type: Unshielded twisted pair (UTP) or shielded twisted pair (STP) cables with RJ-45 connectors; Category 3 or better for 10BASE-T, Category 5 or better for 100BASE-TX, and Category 5, 5e or 6 for 1000BASE-T.
- Make sure that your cables are not damaged and the RJ-45 connectors are well connected.
- For interbuilding connection use fiber-optic cables.
- Copper ports are intended to be used for indoor applications only, suitable for connection to intrabuilding or unexposed wiring or cabling only. The intrabuilding ports of the equipment must not be metalically connected to interfaces that connect to the OSP or its wiring. These interfaces are designed for use as intra-building interfaces only (Type 2 or Type 4 ports as described in GR-1089-CORE, Issue 4) and require isolation from the exposed OSP



cabling. The addition of Primary Protectors is not sufficient protection in order to connect these interfaces metalically to OSP wiring.

- Avoid installing copper cables close to strong electromagnetic fields generated by electric generators, elevator engines, or other similar heavy electric machines.
- Make sure you only use SFPs and XFPs that are supported by Alcatel-Lucent.

---

## Equipment Checklist

After unpacking your switch, check the contents to make sure all the components are present. Before installation, make sure you have all the necessary equipment.

# Installing Your Switch

---

## Rack Mounting

If you plan to rack-mount your switch, make sure you have the following equipment available:

- Four mounting screws for each device you plan to install in a rack (not included)
- A screwdriver (Phillips or flathead, depending on the type of screws used)

To rack-mount your 7210 SAS E:

**Step 1** Attach the brackets to the device using the screws provided in the Bracket Mounting Kit. See [Figure 8](#).

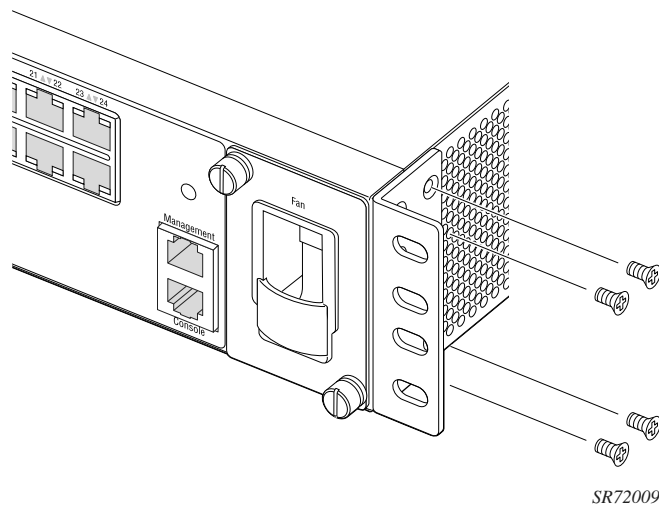

**Figure 8: Attaching the Brackets**

**Step 2** Mount the 7210 SAS E in the rack, using four rack-mounting screws (not provided). See [Figure 9](#).

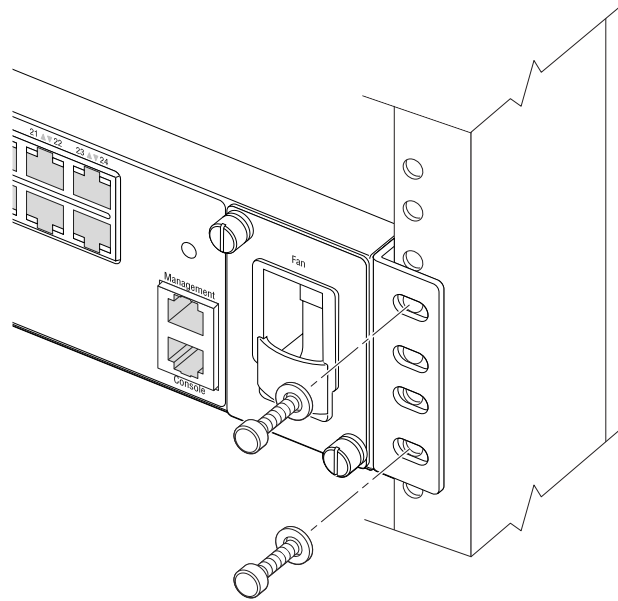

SR72010

**Figure 9: Installing the Switch in a Rack**

- Step 3** If you are installing a single switch, proceed to ["Grounding the Chassis" on page 37](#).
- Step 4** If installing multiple switches, mount them in the rack, one below the other, in any order.

## Desktop or Shelf Mounting

**Step 1** Attach the four adhesive feet to the bottom of the first switch. See [Figure 10](#).

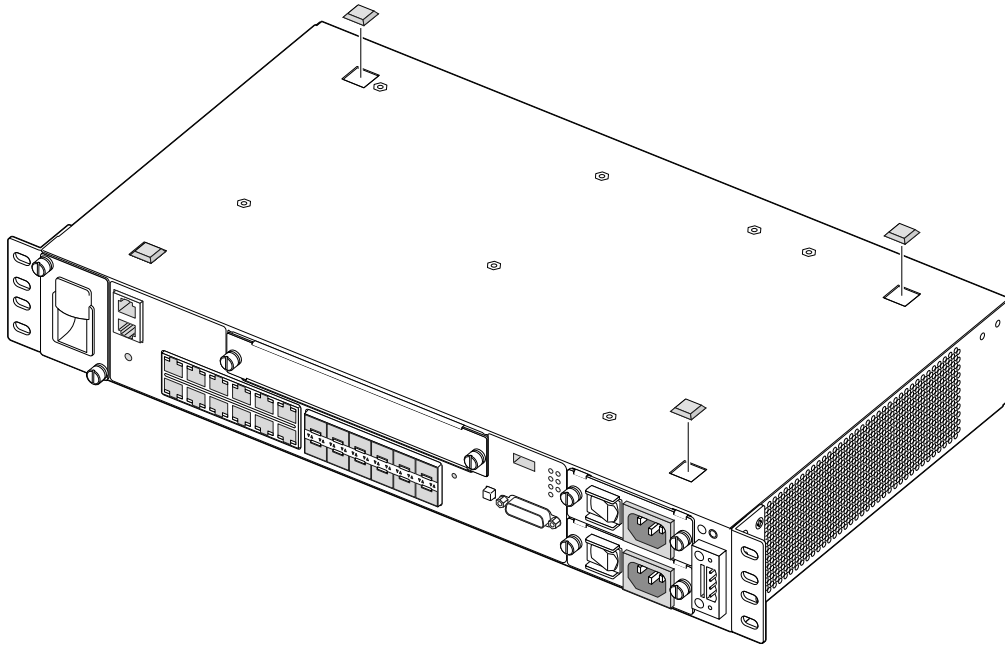

SR72011

**Figure 10: Attaching the Adhesive Feet**

- Step 2** Set the device on a flat surface near an external power source, making sure there are at least three inches of space on the front and sides for proper air flow.
- Step 3** If you are installing a single switch, proceed to "[Grounding the Chassis](#)" on [page 37](#).
- Step 4** If you are installing multiple switches, attach four adhesive feet to each switch. Place each device squarely on top of the one below, in any order.

## Grounding the Chassis

Before powering on the switch, ground the switch to earth as described below.

- Step 1** Ensure that the rack on which the switch is to be mounted is properly grounded.
- Step 2** Ensure that you have made a suitable electrical connection to the grounding point on the rack. Ensure that no paint or isolating surface treatment is present on the grounding point.
- Step 3** Disconnect all power cables to the switch.
- Step 4** The switch chassis is connected internally to 0 V. This circuit is connected to the double-hole grounding terminal on the rear of the switch (lower right corner) using Metric M4-.7 pitch screws and a Panduit LCCF8-14A-L or compatible ground lug. The surface area around this terminal is not painted in order to provide for a good connection. Attach a #8 AWG stranded copper wire to the grounding terminal on the switch.
- Step 5** Attach the grounding wire to the ground point on the rack.



### CAUTION

The earth connection must not be removed unless all supply connections have been disconnected.

## Connecting to a Power Source

This switch supports both AC and DC power supply modules.



**NOTES:**

The switch is designed to accept up to two AC and/or two DC power supplies.

---

## Connecting to AC Power



**NOTE:**

In order to comply with the GR-1089 Lightning Criteria for Equipment Interfacing With AC Power Ports, an external Surge Protective Device (Perma Power Model # PXD309) is intended to be used at the AC input of the router.

To connect the switch to a power source:

- Step 1** Verify that the external AC power supply has the following rating: 100-240VAC, 50/60 Hz, 2A.
- Step 2** Make sure the AC power module is installed and powered OFF before you plug the power cable into the AC power source.
- Step 3** Check the power module LEDs as the switch is powered on to verify that the AC LED indicating external power status is on, and that the +12V LED indicating internal power conversion is on. If not, recheck the power supply and power cable connections at the supply source and at the power module.
- Step 4** A redundant AC power module may be hot swappable plugged in. However, for safety precautions the main power cord should be connected after the AC power module is installed.
- Step 5** If you have installed both primary and redundant power supply modules, verify that the LEDs on both modules are lit as indicated in the preceding step.

## Connecting to DC Power

The 7210 SAS-E chassis supports the -48V and +24V DC power modules. Hence, the steps below are applicable for either the -48V or the +24V DC power modules.



**Notes:** Below the DC power entry block is an additional chassis ground point for attaching a DC power chassis ground if required by local electrical codes. The ground point should be connected with an M4 screw and a terminal lug as specified by local electrical codes.

---



**Notes:** Do NOT install BOTH the -48V and the +24V AC PEMs in the same chassis.

---



**Notes:** If a single power feed (either #A or #B) is connected to provide power to the system, it supplies power to both the power supplies, if both of them plugged in. The DC power feeds, #A and #B, are internally bridged using a diode.

---

To connect DC power:

**Step 1** Before a VDC power supply module can be used, you must connect an external DC power source to the DC power connection on the left side of the front panel (see [Figure 1](#)). The external DC power supply must be between -36 to -72 VDC, and protected with a circuit breaker.



### WARNING:

Before wiring the DC plug or connecting power to the switch, ensure that power to the feed lines is turned off at the supply circuit breaker or disconnected from the power bus.

---

**Step 2** To provide adequate circuit protection between the DC power supply and the switch, all intermediate wiring and circuitry should be rated to carry a load at least two times the maximum rating for this switch (see "[Appendix A: Specifications](#)" on page 75).

**Step 3** The wiring between the DC power supply and the switch must be stranded copper wire within the range of 16 to 20 AWG.

**Step 4** Connect the VDC power feed using the VDC input and RETA/B (return) lines for power source A and B, respectively. Insert the wires into the DC input plug (using a small flat-tip screwdriver). Color code the wiring according to local standards to ensure that the input power and ground lines can be easily distinguished.

Figure 11 illustrates how to connect a -48 VDC power source to the chassis:

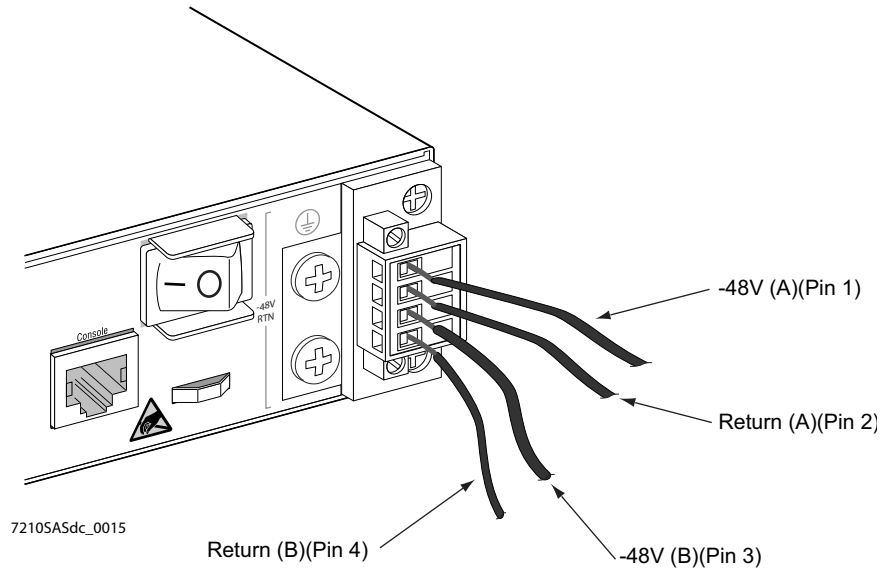

**Figure 11: Connecting to a -48 VDC Power Source**

Figure 12 illustrates how to connect a +24 VDC power source to the chassis:

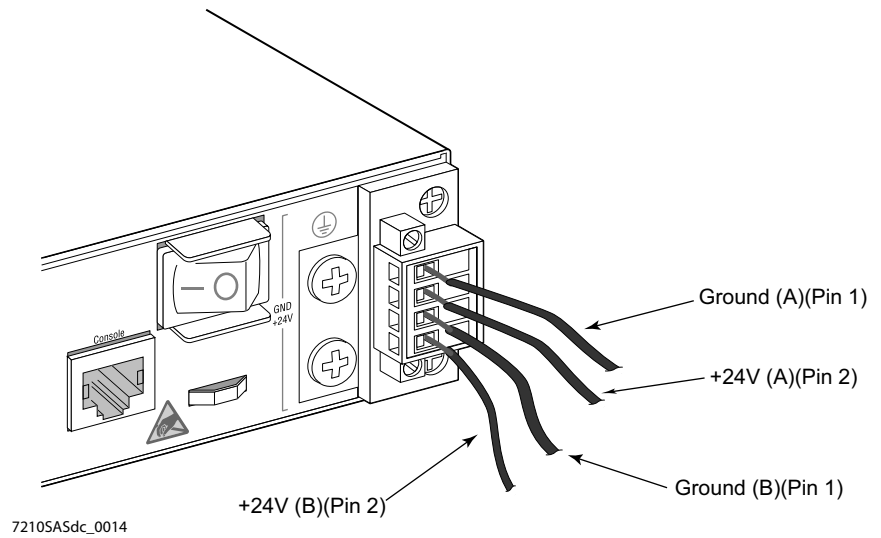

**Figure 12: Connecting to a +24 VDC Power Source**



**WARNING:**

If the power leads are plugged into the wrong holes, the power supply will not work properly and may damage the switch.

- 
- Step 5** After the power source is tuned on, set the power button on the front of the power supply module to the ON position (marked “—”).
- Step 6** Check the LEDs on the power supply module as the switch is powered on to verify that the -48V/+24V LED indicating external power status is on, and that the +12V LED indicating internal power conversion is on. If not, recheck the power supply and power cable connections at the supply source and at power supply module.
- Step 7** If you have installed both a primary and redundant power supply module, verify that the LEDs on both modules are lit as indicated in the preceding step.
- 

## Connecting to the Console Port

The RJ-45 serial port on the front panel is used to connect to the switch for out-of-band console configuration. The on-board configuration program can be accessed from a terminal or a PC running a terminal emulation program.

The pin assignments used to connect to the serial port are provided in [Table 11](#).

**Table 11: Serial Cable Wiring**

RJ45	Pin	Usage
RTS	1	Used as defined. Should be connected
NC	2	Not used. Should not be connected
TXD	3	Used as defined. Should be connected
GND	4	Used as defined. Should be connected
GND	5	Used as defined. Should be connected
RXD	6	Used as defined. Should be connected
NC	7	Not used. Should not be connected
CTS	8	Used as defined. Should be connected



---

This chapter describes how to replace Small Form Factor Pluggable (SFP) transceivers on ports that support these devices.

- ["Warnings and Notes" on page 44](#)
- ["Installation Preparation" on page 45](#)

## Warnings and Notes



**Danger:**

- Fiber optic equipment can emit laser or infrared light that can injure your eyes. Never look into an optical fiber or connector port. Always assume that fiber optic cables are connected to a light source.



**Caution:**

- Make sure the plug is inserted while you install or remove the SFP. *Only* remove the plug when you are ready to attach network cables.
- Electrostatic discharge (ESD) damage can occur if router components, including SFPs, are mishandled. Always wear an ESD-preventive wrist or ankle strap and always connect an ESD strap to the grounding plug on the front of the chassis.
- Always place router components on an anti-static surface.
- Avoid bending fiber optic cable beyond its minimum bend radius.
- Do not exceed the recommended minimum 1 1/2-inch (3.81 cm) bend radius for fiber optic cables.



**Warning:**

- Do not remove the dust cover on the connector until you are ready to install the SFP. Always replace the the dust cover when the SFP is removed.



**Notes:**

- Discard SFPs according to all local laws and regulations.
- SFPs are keyed to prevent incorrect insertion.

## Installation Preparation

Clean the connector before inserting it to prevent transfer of small particles and contamination of the transceiver. Do not interchange SFPs from one port to another without first cleaning the connectors.

To clean the connector, you can either:

- Wipe the side and end of the ferrule with a lint-free alcohol-dampened cloth.
  - Blow dry the ferrule with compressed air and inspect for lint. Do not insert the compressed air nozzle into the receptacle when blowing out.
- 

## Locking Mechanisms

Alcatel-Lucent SFPs can use different lock and release methods. Possible lock and release mechanisms include:

- Locking handle—A locking handle (lever) in the front of the SFP that you gently raise or lower to insert or remove from the port.
- Bail—A bar or wire latch in the front of the SFP that you pull down and outward to release the module.
- Tabs on the sides of the SFP that you press inward.

## Installing SFPs

To install an SFP transceiver:

- Step 1** Remove the SFP from its anti-static packaging.
  - Step 2** Holding the SFP by its sides, slide the unit into the port until it clicks into place.
  - Step 3** Remove the plug from the SFP optical bore when you are ready to attach the network cable.
- 

## Removing SFPs

If you are removing an SFP, have a replacement SFP or slot plug, an anti-static mat, and a safety cap for the SFP transceiver ready.

To remove an SFP:

- Step 1** Disconnect the network cable from the optical connector.
- Step 2** Pull the lever located in the front of the SFP with your thumb and forefinger. Slide the connector out of the port.
- Step 3** Place the SFP on an anti-static mat or in an electro-static bag.
- Step 4** Install an SFP replacement or re-insert the plug.
- Step 5** Connect the network cable or place a safety cap over the optical transceiver.

# Configuring the 7210 SAS-E

---

This chapter describes how to configure your 7210 SAS-E and contains the following sections:

- ["Diagnostics" on page 48](#)
- ["Initializing the System and Downloading Software" on page 49](#)
- ["Establishing Router Connections" on page 66](#)
- ["Restarting the Router" on page 69](#)

## Diagnostics

---

### Post Installation Status

After successfully installing the switch, ensure that the LEDs show the following state:

- Critical: OFF
- Major: OFF
- Fan: OFF
- Status: Steady GREEN

If any of the above LEDs shows a different state, reset the hardware using reset procedure mentioned in "Restarting the Router" to let the system boot.



## Initializing the System and Downloading Software

The 7210 SAS-E ships with bootloader and TiMOS in flash. When the system is powered up for the first time, the bootloader will attempt an auto-init procedure (see the System Basics Guide for more information). The auto-init can, however, be interrupted and the boot operation can be controlled manually.



**Note:** By default, 7210 platforms attempt the autoinit procedure unless interrupted by user and forced to use Timos available in the flash.

---

### Booting a 7210 SAS-E in the Lab

There are several ways to boot the 7210 SAS-E from the network. User can choose to boot the device using one of the following options:

- Using the image shipped along with the box to boot the device
- Using the network to load the image and boot the device

The following sections describe how to boot the device using either of the options listed above.

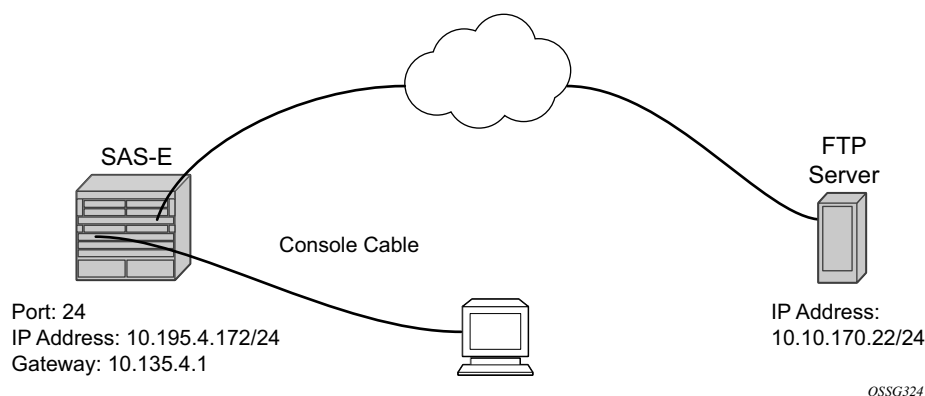

**Figure 13: 7210 SAS-E Boot Process**

## Booting a 7210 SAS-E using the image on Flash (with the image shipped by factory)

You will need the following:

- A PC with a serial port and Hyperterminal
- Cable that connects the console port of SAS-E to the serial port of PC

Connect the 7210's console port to serial port of the PC and then power on the 7210. The system will start booting up with messages on the console similar to those shown below. Follow the procedure given below to boot the system with the image on the flash.

```
Resetting...OK
Alcatel-Lucent 7210 Boot ROM. Copyright 2009-2011 Alcatel-Lucent.
All rights reserved. All use is subject to applicable license agreements.
Testing ROM load area...done
Relocating code...Jumping to RAM
Performing second stage RAM test...passed
Board Serial Number is 'NS1111C0115'
Bootlog started for Version A-V-3.0.B5-85
Build V-3.0.B5-85 bootrom/mpc 7xxx
Built on Wed Apr 20 13:52:05 IST 2011 by builder in /builder/3.0B5/panos/main
?Attempting to load from file cf1:/boot.tim
Version L-3.0.B5-85, Wed Apr 20 14:13:38 IST 2011 by builder in /builder/3.0B5/
panos/main
text:(4782384-->20108848) + data:(1084015-->3891872)
Starting at 0xb000000...
PCIE: Port 0 Link UP
Total Memory: 512MB Chassis Type: sas Card Type: badami_7210
TiMOS-L-3.0.B5-85 boot/mpc ALCATEL SAS-E 6F4T 7210 Copyright (c) 2000-2011
Alcatel-Lucent.
All rights reserved. All use subject to applicable license agreements.
Built on Wed Apr 20 14:13:38 IST 2011 by builder in /builder/3.0B5/panos/main
TiMOS BOOT LOADER
Time from clock is THU APR 21 11:03:21 2011 UTC
Switching serial output to sync mode... done
```

Since the switch does not ship with a BOF, it will show the default settings.

```
Looking for cf1:/bof.cfg ... not found
Could not find bof.cfg on any of the local drives.
Default Settings:
```

```
-----
Contents of Boot Options File on cf1:
#uplinkA Port Settings:
uplinkA-port 1/1/1
uplinkA-address 0
uplinkA-vlan 0
#uplinkB Port Settings:
```

```
uplinkB-port 1/1/2
uplinkB-address 0
uplinkB-vlan 0
#System Settings:
wait 3
persist off
console-speed 115200
Hit a key within 2 seconds to change boot parameters...
```

Press any key.

```
Enter password to edit the Boot Options File
Or CTRL-D to exit the prompt
Password:
```

The default password is 'password'.

```
You must supply some required Boot Options. At any prompt, you can type:
"restart" - restart the query mode.
"reboot" - reboot.
"exit" - boot with with existing values.
"diag" - enter the diag shell.
"reset" - reset the bof and reboot.
Press ENTER to begin, or 'flash' to enter firmware update...
```

Press Enter.

```
Software Location
-----
You must enter the URL of the TiMOS software.
The location can be on a Compact Flash device,
or on the network.
Here are some examples
cf1:/timos1.0R1
ftp://user:passwd@192.168.1.150/./timos1.0R1
tftp://192.168.1.150/./timos1.0R1
Software Image URL:
Enter the software URL. (For example, cf1:/both.tim)
```

At prompt above enter the location of the image. When the device ships from the

```
factory the image is typically available at cf1:/both.tim
Configuration File Location
-----
You must enter the location of configuration
file to be used by TiMOS. The file can be on
a Compact Flash device, or on the network.
Here are some examples
cf1:/config.cfg
ftp://user:passwd@192.168.1.150/./config.cfg
tftp://192.168.1.150/./config.cfg
No existing Config URL
Press ENTER, or type 'none' for no Config URL.
Config File URL:
```

## Initializing the System and Downloading Software

Enter the location of the configuration file. Or none since you are booting for the first time. You can skip all the remaining prompt that appear on the screen by pressing 'ENTER' until to get to the following prompt

```
New Settings
-----
primary-image cfl\both.tim
primary-config cfl:\config.txt
#uplinkA Port Settings:
uplinkA-port 1/1/10
uplinkA-address 10.135.4.172/10
uplinkA-vlan 0
uplinkA-route 10.10.170.0/10 next-hop 10.135.4.1
#System Settings:
wait 3
persist off
console-speed 115200
Do you want to overwrite cfl:/bof.cfg with the new settings? (yes/no):
Type yes and press Enter. The 7210 SAS-E should boot now.
Primary image location: cfl:/both.tim
Loading image cfl:/both.tim
Version B-3.0.B5-85, Wed Apr 20 14:32:04 IST 2011 by builder in /builder/
3.0B5/panos/main
text:(25059814-->122242456) + data:(3179598-->18748616)
Executing TiMOS image at 0x100000
```

After the 7210 SAS-E boots up, you should see the following prompt:

```
All rights reserved. All use subject to applicable license agreements.
Built on Wed Apr 20 14:32:04 IST 2011 by builder in /builder/3.0B5/panos/
main
Login:
```



**Note:** The SYS LED will be Green when the device has successfully completed the boot process and is running normally.

The default username and password are admin. Log into the 7210 SAS-E. To establish either console connection or Telnet connection to the router after successful boot, please see "[Establishing Router Connections](#)" on page 66.

## Booting a 7210 SAS-E From the Network

There are several ways to boot the 7210 SAS-E from the network. User has options to use one of the front panel ports (referred to as uplinkA and uplinkB in the display output shown below) or the out-of-band ethernet management port (referred to as eth-mgmt port in the display output shown below) to boot the 7210 SAS-E from the network. By default, the out-of-band ethernet management port is disabled. User needs to enable it before using it for manual boot. The example below shows how this can be done. The example described below shows how to boot the 7210 SAS using FTP servers and the manual boot process. For more information about booting your 7210 SAS, please refer to the System Basics Guide. Figure 13 shows the network diagram used in the example below. Additionally, you may want to store the TiMOS image on the internal flash if you want to boot from the flash later.

You will need the following:

- A FTP server
- TiMOS image
- A PC with a serial port and Hyperterminal
- Cable that connects the console port of SAS-E to the serial port of PC
- A network cable to connect the 7210 unit to the network

Prepare the set up as shown in the diagram above.

When you are done, power on the 7210 SAS-E.

Using the uplink port to boot 7210 from the network:

```

Resetting...OK

Ø

Alcatel-Lucent 7210 Boot ROM. Copyright 2000-2009 Alcatel-Lucent.

All rights reserved. All use is subject to applicable license agreements.

Running POST tests from ROM

Testing ROM load area...done

Relocating code...Jumping to RAM

Performing second stage RAM test....passed

```

## Initializing the System and Downloading Software

```
Board Serial Number is 'SN12345678'  
Bootlog started for Version V-1.0.R1  
Build V-1.0.R1 bootrom/mpc 7xxx  
Built on Thu Jan 15 14:55:59 IST 2009 by builder in /builder/ws/panos/main  
...
```

Since the router does not ship with a BOF, it will show the default settings.

```
Looking for cf1:/bof.cfg ... not found  
Could not find bof.cfg on any of the local drives.
```

### Default Settings:

```
-----  
-----  
Contents of Boot Options File on cf1:  
#eth-mgmt Port Settings:  
  eth-mgmt-disabled  
#uplinkA Port Settings:  
  uplinkA-port      1/1/1  
  uplinkA-address   0  
  uplinkA-vlan      0  
#uplinkB Port Settings:  
  uplinkB-port      1/1/2  
  uplinkB-address   0  
  uplinkB-vlan      0  
#System Settings:  
  wait              3  
  persist           off  
  console-speed     115200  
Hit a key within 2 seconds to change boot parameters...
```

Press any key.

```
Enter password to edit the Boot Options File  
Or CTRL-D to exit the prompt
```

```
Password:
```

The default password is password.

```
You must supply some required Boot Options. At any prompt, you can type:  
"restart" - restart the query mode.  
"reboot"  - reboot.  
"exit"    - boot with with existing values.
```

"diag" - enter the diag shell.  
"reset" - reset the bof and reboot.

Press ENTER to begin, or 'flash' to enter firmware update...

**Press Enter.**

Software Location

-----

You must enter the URL of the TiMOS software.  
The location can be on a Compact Flash device,  
or on the network.

Here are some examples

cf1:/timos1.0R1  
ftp://user:passwd@192.168.1.150/./timos1.0R1  
tftp://192.168.1.150/./timos1.0R1

Software Image URL:

**Enter the software URL. (For example, ftp://  
<user>:<password>@10.10.170.22/./images/both.tim)**

Configuration File Location

-----

You must enter the location of configuration  
file to be used by TiMOS. The file can be on  
a Compact Flash device, or on the network.

Here are some examples

cf1:/config.cfg  
ftp://user:passwd@192.168.1.150/./config.cfg  
tftp://192.168.1.150/./config.cfg

No existing Config URL

## Initializing the System and Downloading Software

Press ENTER, or type 'none' for no Config URL.

Config File URL:

**Enter the location of the configuration file. Or none since you are booting for the first time.**

Boot Interface Management

-----

You specified a network location for either the software or the configuration file. You need to, configure either uplinkA or uplinkB ports.

You will be asked to configure the port number, IP address, static routes, and VLAN Id for uplink ports.

uplinkA Port Setting

-----

Existing uplinkA port settings are:

uplinkA-port	1/1/1
uplinkA-address	0
uplinkA-vlan	0

uplinkA port is configured for Boot Interface Management,

Press ENTER to proceed with existing port settings

Or "disable" to disable the port for Boot Interface Management

Or "edit" to change the port settings:

**Type edit.**

Existing uplinkA port for Boot Interface Management is port 1/1/1.

Press ENTER to keep it.

Enter the new uplinkA port number for Boot Interface Management:

**Enter the port which it connected to the network (for example, 1/1/24).**

You need to assign an IP address for this port.

The IP address should be entered in standard



dotted decimal form with a network length.

example: 192.168.1.169/24

Or type "0" to obtain IP address and static route through DHCP. Existing IP address and static routes will be deleted.

uplinkA port is configured to obtain IP address and static route through dhcp.

Press ENTER to keep it.

Enter uplinkA port IP Address:

**Enter the IP address and the mask that the device should use (for example, 10.135.4.172/24).**

**Since the FTP server is on a different subnet, you will have to enter IP routing information:**

You specified network locations which might require static routes to reach. You will be asked to enter static routes until all the locations become reachable.

Static routes should be entered in the following format:

prefix/mask next-hop ip-address

example: 192.168.0.0/16 next-hop 192.168.1.254

Would you like to add a static route? (yes/no)

Type yes and press **Enter**.

Enter route:

**Enter a static route to the FTP server's subnet (for example, 10.10.170.0/24 next-hop 10.135.4.1) at the prompt.**

You need to configure the VLAN Id for this port  
VLAN Id can be between 0 to 4094. To send out packets with out any VLAN tags, type "null".

## Initializing the System and Downloading Software

Existing VLAN Id for uplinkA port is VLAN Id 0.

Press ENTER to keep it.

Enter the new VLAN Id for uplinkA port:

Press **Enter** if you want to send out untagged packets. Otherwise, enter the VLAN tag.

uplinkB Port Setting

-----

uplinkB port is disabled for Boot Interface Management,

Press ENTER to proceed with no uplinkB port settings

Or "enable" to enable the port for Boot Interface Management:

Enter disable since we do not want the backup link.

Press **Enter**.

New Settings

-----

primary-image ftp://\*:10.10.170.22/./images/both.tim

primary-config cfl:\config.txt

#uplinkA Port Settings:

uplinkA-port 1/1/24

uplinkA-address 10.135.4.172/24

uplinkA-vlan 0

uplinkA-route 10.10.170.0/24 next-hop 10.135.4.1

#System Settings:

wait 3

persist off

console-speed 115200

Do you want to overwrite cfl:/bof.cfg with the new settings? (yes/no):

Type **yes** and press **Enter**. The 7210 SAS-E should boot now.

Primary image location: ftp://\*:10.10.170.22/./images/both.tim

Initializing uplinkA port using IP addr 10.135.4.172.

## Configuring the 7210 SAS-E

```
Loading image ftp://*:10.10.170.22/./images/both.tim  
Version B-1.1.private, Wed Jul 15 17:18:37 IST 2009 by builder in /builder/  
ws/1.0B1/main  
  
text:(17446113-->76798004) + data:(2100172-->10874132)  
Executing TiMOS image at 0x100000  
...
```

After the 7210 SAS-E boots up, you should see the following prompt:

```
All rights reserved. All use subject to applicable license agreements.  
Built on Wed Jul 15 17:18:37 IST 2009 by builder in /builder/ws/1.0B1/sultan
```

Login:

The default username and password are admin. Log into the 7210 SAS-E.



**Note:** The status LED will be Green when the device has successfully completed the boot process and is running normally.

---

## Using the Out-of-Band Ethernet Management port to boot 7210 from the network



---

**Note:** Use of this feature requires an upgrade of the bootloader software, to a version in which support for Out-of-Band Management port is available. Please check the release notes for more information.

---

Follow the same procedure as used for a uplink port until the following prompt is displayed. Use the following procedure to use the out-of-band ethernet management port to boot 7210 from the network.

```
eth-mgmt Port Setting
-----
The eth-mgmt port is disabled for Boot Interface Management Press ENTER to
proceed with no eth-mgmt port settings. Or "enable" to enable the port for
Boot Interface Management: enable
```

At the above prompt enter 'enable' as shown to enable the use of out-of-band ethernet management port for boot.

```
You need to assign an IP address for this port.
The IP address should be entered in standard
dotted decimal form with a network length.
example: 192.168.1.169/24
Enter eth-mgmt IP Address :
```

Enter the IP address and mask that the device should use (for example, 10.135.4.172/24).

Since the FTP server is on a different subnet, you will have to enter IP routing information using the Out-of-Band Ethernet Management port to boot 7210 from the network.

```
Network Configuration
-----

Boot Interface Management
-----
You specified a network location for either the
software or the configuration file. You need to
configure either eth-mgmt or uplinkA or uplinkB ports.
You will be asked to configure the port number, IP address,
static routes, and VLAN Id in case of uplink ports.

You specified network locations which might require
static routes to reach. You will be asked to
enter static routes until all the locations become
reachable.
Static routes should be entered in the following format:
```

```

prefix/mask next-hop ip-address
example:      192.168.0.0/16 next-hop 192.168.1.254

Would you like to add a static route? (yes/no) yes
Enter ip route:

```

Enter a static route to the FTP server's subnet (for example, 10.10.170.0/24 next-hop 10.135.4.1) at the prompt.

The device then prompts the user to configure the uplinkA and uplinkB port. Since we intend to use the ethernet management port at the following prompts disable the use of uplink ports as shown below.

```

uplinkA Port Setting
-----
Existing uplinkA port settings are:

uplinkA-port      1/1/1
uplinkA-address   0
uplinkA-vlan      0

uplinkA port is configured for Boot Interface Management,
Press ENTER to proceed with existing port settings
Or "disable" to disable the port for Boot Interface Management
Or "edit" to change the port settings:

uplinkB Port Setting
-----
Existing uplinkB port settings are:

uplinkB-port      1/1/2
uplinkB-address   0
uplinkB-vlan      0

uplinkB port is configured for Boot Interface Management,
Press ENTER to proceed with existing port settings
Or "disable" to disable the port for Boot Interface Management
Or "edit" to change the port settings:

uplinkB port will be disabled for Boot Interface Management

New Settings
-----
primary-image      ftp://*:*@10.10.170.22/./images/both.tim
#eth-mgmt Port Settings:
no eth-mgmt-disabled
eth-mgmt-address   10.135.25.97/24
eth-mgmt-route     10.135.0.0/16 next-hop 10.135.25.1
eth-mgmt-route     135.254.0.0/16 next-hop 10.135.25.1
eth-mgmt-autoneg
eth-mgmt-duplex    full
eth-mgmt-speed     100
#System Settings:
wait               3

```

## Initializing the System and Downloading Software

```
persist          off
console-speed    115200
```

```
Do you want to overwrite cf1:/bof.cfg with the new settings? (yes/no): yes
```

Type yes and press Enter.

The 7210 SAS-E should boot now.

```
Successfully saved the new settings in cf1:/bof.cfg

Configuring Network with eth-mgmt Port Setting.....
No existing config file URL

Primary image location: ftp://*:10.10.170.22/./images/both.tim
Loading image ftp://*:10.10.170.22/./images/stu-hw/both.tim
Version B-2.0.B1-57, Tue Jul 13 23:24:58 IST 2010 by builder in /builder/
2.0B1/panos/main
text:(24285906-->114984824) + data:(2989128-->18305224)
Executing TiMOS image at 0x100000
.....
```

After the 7210 SAS-E boots up, you should see the following prompt:

```
All rights reserved. All use subject to applicable license agreements.
Built on Tue Jul 13 23:24:58 IST 2010 by builder in /builder/2.0B1/panos/
main
Login:
```

The default username and password are admin. Use it to log into the device.

Note: The status LED will be Green when the device has successfully completed the boot process and is running normally. It is highly recommended that you change the default admin password to prevent unauthorized access to the node.

## Downloading the TiMOS software to the internal flash

If you want to boot the SAS-E from the internal flash, you will have to copy the image there.

If you have used the uplinkA or uplinkB port to boot the 7210, use any of the network ports for IP connectivity and follow the procedure given below to configure an IP interface and a route.

If you have used the out-of-band ethernet management port, then you do not need to configure the IP interface. Instead jump to the step "Check IP connectivity" below and continue from there.

Change the mode of the connected port to 'access uplink'

```
A:SN12# configure port 1/1/24
A:SN12>config>port#
A:SN12>config>port# ethernet mode access uplink
A:SN12>config>port# no shutdown
A:SN12>config>port# exit
```

Configure an IES service.

```
A:SN12# configure service
A:SN12>config>service# info
-----
customer 1 create
    description "Default customer"
exit
ies 2 customer 1 create
    interface "in-band-mgmt" create
        address 10.135.4.172/24
        sap 1/1/24:0.* create
        exit
    exit
    no shutdown
    exit
-----
A:SN12>config>service#
```

Configure a route to the FTP server.

```
A:SN12#configure router
A:SN12>config>router#
```

## Initializing the System and Downloading Software

```
A:SN12>config>router# static-route 10.10.170.0/24 next-hop 10.135.4.1
A:SN12>config>router#
```

Check IP connectivity:

```
A:SN12# ping 10.10.170.22 source 10.135.4.172
PING 10.10.170.22 56 data bytes
64 bytes from 10.10.170.22: icmp_seq=1 ttl=251 time<1ms.
64 bytes from 10.10.170.22: icmp_seq=2 ttl=251 time<1ms.
64 bytes from 10.10.170.22: icmp_seq=3 ttl=251 time<1ms.
64 bytes from 10.10.170.22: icmp_seq=4 ttl=251 time<1ms.
64 bytes from 10.10.170.22: icmp_seq=5 ttl=251 time<1ms.

---- 10.10.170.22 PING Statistics ----
5 packets transmitted, 5 packets received, 0.00% packet loss
round-trip min < 1ms, avg < 1ms, max < 1ms, stddev < 1ms
A:SN12#
```

### Configure the primary-config in the BOF and save the config

```
A:SN12# bof primary-config cf1:/config.txt
*A:SN12# bof save
Writing BOF to cf1:/bof.cfg
Saving BOF .... Completed.

A:SN12# admin save
Writing file to cf1:\config.txt
Saving configuration .... Completed.
A:SN12#
```

### Copy the TiMOS image from the FTP server to the flash:/

```
A:SN12# file copy ftp://<user>:<passwd>@10.10.170.22/./images/both.tim
cf1:/both.tim
Copying file ftp://<user>:<passwd>@10.10.170.22/./images/both.tim...
```



```
1 file copied.
```

```
A:SN12#
```

**Configure the BOF to pick up the image from internal flash:**

```
A:SN12# bof primary-image cf1:/both.tim
```

```
*A:SN12# bof save
```

```
Writing BOF to cf1:/bof.cfg
```

```
Saving BOF .... Completed.
```

```
A:SN12#
```

**Reboot the SAS-E. The device will pick up both the image and the configuration from the internal flash.**

## Establishing Router Connections

Access your newly installed switch two ways:

- ["Console Connection" on page 66](#)
- ["Telnet Connection" on page 67](#)

---

### Console Connection

To establish a console connection, you will need the following:

- An ASCII terminal or a PC running terminal emulation software set to the parameters shown in the table below
- The included RJ-45 serial cable

**Table 12: Console Configuration Parameter Values**

Parameter	Value
Baud Rate	115,200
Data Bits	8
Parity	None
Stop Bits	1
Flow Control	None

To establish a console connection:

- Step 1** Connect the terminal to the console port on the front panel using the serial cable.
- Step 2** Power on the terminal.
- Step 3** Establish the connection by pressing the **Enter** key a few times on your terminal keyboard.
- Step 4** At the router prompt, enter the login and password.  
The default login is `admin`.  
The default password is `admin`.

## Telnet Connection

To access the router after a successful initialization with a Telnet connection from a PC or a workstation, configure an in-band management interface using the Timos CLI. You can configure an in-band management interface using the IES service configuration. Note that IES service is supported only for the in-band management interface.

The following is a sample configuration for configuring an in-band management IP interface using IES service:

```
*A:Dut-A>config>service# info
-----
customer 1 create
description "Default customer"
exit

ies 4001 customer 1 create
interface "inband-mgmt" create
address 10.10.10.25/24
sap 1/1/21:0.* create
exit
exit
no shutdown
exit
```

Telnet access provides the same options for user and administrator access as those available through the console port.

To configure the 7210 SAS-E for Telnet access, you must have a device with Telnet software located on the same network. The 7210 SAS-E must have a management IP interface configured with an IP address. Each 7210 SAS-E is limited to a total of seven inbound/outbound Telnet or SSH sessions to guarantee that either inbound or outbound sessions will be available.

## Establishing Router Connections

MAC addresses are listed on a small label on the chassis. The MAC address also displays in the **show router arp** command output.

The 7210 SAS-E must have a management IP address. The IP address is manually configured.

---

## Running Telnet

Once the IP parameters are configured, you can access the CLI command line with a Telnet connection. To establish a Telnet connection, run a Telnet program and issue the Telnet command, followed by the IP address:

The following displays an example of a Telnet login:

```
C:\>telnet 10.10.10.25
Login: admin
Password: #####

ALA-1#
```

## Restarting the Router

To reset the node, use the following procedure:

- Step 1** Press and hold the Alarm Cut Off (ACO) button.
- Step 2** Press the Reset button for a minimum of 10 seconds before releasing the Reset button.
- Step 3** Release the Alarm Cut Off button.

# Restarting the Router

# Troubleshooting

---

This chapter describes troubleshooting methods and procedures and includes the following sections:

- ["Diagnosing Switch Indicators" on page 72](#)
- ["Power and Cooling Problems" on page 73](#)
- ["Installation" on page 74](#)
- ["In-Band Access" on page 75](#)

## Diagnosing Switch Indicators

This switch can be easily monitored through panel indicators to identify problems. [Table 13](#) describes common problems you may encounter and possible solutions.

**Table 13: Troubleshooting**

Symptom	Possible Cause	Action
Power Module LED is OFF +12 VDC or AC	Power outlet, power cord, or power module may be defective.	<ul style="list-style-type: none"> <li>• If using a DC power supply module, check the connections between the switch and the external DC power supply. If using an AC power module, check connections between the switch, the power cord, and the wall outlet.</li> <li>• Contact your dealer for assistance.</li> </ul>
Power Module LED is OFF +12 VDC	Power module may be defective.	<ul style="list-style-type: none"> <li>• Internal power supply has failed. Contact your local dealer for assistance.</li> </ul>
Critical LED is RED	Critical alarm detected.	<ul style="list-style-type: none"> <li>• One or more critical system alarm(s) have occurred.</li> </ul>
Major LED is RED	Major alarm detected.	<ul style="list-style-type: none"> <li>• One or more major system alarm(s) have occurred.</li> </ul>
Fan LED is RED	Fan failure.	<ul style="list-style-type: none"> <li>• One or more fans in the fan tray have failed. Replace the fan tray.</li> </ul>
Status LED is Off or AMBER	Boot-up diagnostic program has detected a problem.	<ul style="list-style-type: none"> <li>• Power cycle the switch to try and clear the condition.</li> <li>• If the condition does not clear, contact your local dealer for assistance.</li> </ul>
Link LED is Off	Network cable or Ethernet device attached to this port may be defective.	<ul style="list-style-type: none"> <li>• Verify that the switch and attached device are powered on.</li> <li>• Be sure the cable is plugged into both the switch and corresponding device.</li> <li>• Verify that the proper cable type is used and its length does not exceed specified limits.</li> <li>• Check the adapter on the attached device and cable connections for possible defects. Replace the defective adapter or cable if necessary.</li> </ul>
Management LED is OFF		



## Power and Cooling Problems

If the power indicator does not turn on when the power cord is plugged in, you may have a problem with your power outlet, power cord, or internal power supply. However, if the unit powers off after running for a while, check for loose power connections, power losses or surges at the power outlet, and verify that the fans on the unit are unobstructed and running prior to shutdown.

## Installation

Verify that all system components have been properly installed. If one or more components appear to be malfunctioning (such as the power cord or network cabling), test them in an alternate environment where you are sure that all the other components are functioning properly.

## In-Band Access

You can access the management agent in the switch from anywhere within the attached network using Telnet or network management software tools. However, you must first configure the switch with a valid IP address, subnet mask, and default gateway.

If you have trouble establishing a link to the management agent, check to see if you have a valid network connection. Then verify that you entered the correct IP address. Also, be sure the port through which you are connecting to the switch has not been disabled. If it has not been disabled, then check the network cabling that runs between your remote location and the switch.



**NOTE:**

The management agent can accept up to four simultaneous Telnet sessions. If the maximum number of sessions already exists, an additional Telnet connection will not be able to log into the system.



# Appendix A: Specifications

---

This appendix provides system specifications and includes the following sections:

- ["Specifications" on page 78](#)

## Specifications

**Table 14: 7210 SAS-E Specifications**

Item	Width	Height	Depth
<b>Physical dimensions</b>			
Size	17.17" (43.6 cm)	2.64" (1.5RU) (6.7 cm)	9.96" (25.3 cm)
Weight	11 lbs. (5 kg)		
<b>Environmental</b>			
Operating Temperature	0° C to 50° C (32° F to 122° F) (standard) IEC 68-2-14		
Humidity	5% to 95% non-condensing		
Vibration	IEC 68-2-36, IEC 68-2-6		
Shock	IEC 68-2-29		
Drop	IEC 68-2-32		
Telcordia NEBS	Design to meet NEBS level 3		
<b>Input</b>			
Input voltage	-36VDC ~ -72VDC, Output: +12VDC 100~240 V, 50~60 Hz, Output: +12VDC Dual input power redundancy, with current sharing and hot-swap.		
Maximum power consumption	200 W		
<b>Safety, EMC and Immunity</b>			
Safety	CSA/NRTL (UL60950-1, CSA 22.2.No 60950-1) TUV/GS (EN60950-1) CB (EN60950-1)		

**Table 14: 7210 SAS-E Specifications (Continued)**

Item	Width	Height	Depth
EMC	Europe CE Mark: EN55022 Class A EN 300 386 North America: FCC 47 CFR Part 15 Class A ICES-003 Class A (Canada) Japan: VCCI CISPR 22 Class A Australia/New-Zeeland: C-Tick, CISPR 22 Class A		
Immunity	EN55024, EN/IEC 61000-4-2/3/4/6/8/11		

---

## Japan VCCI Class A Declaration

This is a Class A product based on the standard of the Voluntary Control Council for Interference by Information Technology Equipment (VCCI). If this equipment is used in a domestic environment, radio disturbance may arise. When such trouble occurs, the user may be required to take corrective actions.

---

## RoHS and WEEE

Comply with European RoHS and WEEE requirements.

Comply with the Chinese RoHS legislations.





# Appendix B: Pin Assignments

---

This appendix contains pin assignments and includes the following sections:

- ["Management Port Pin Assignments" on page 82](#)
- ["Console Port Pin Assignment" on page 83](#)

## Management Port Pin Assignments

Use unshielded twisted-pair (UTP) or shielded twisted-pair (STP) cable for RJ-45 connections and 100-ohm Category 3, 4, or 5 cable for 10 Mbps connections or 100-ohm Category 5 cable for 100 Mbps connections. Make sure that the length of any twisted-pair connection does not exceed 100 meters (328 feet).

The RJ-45 ports on the switch base unit support automatic MDI/MDI-X operation, so you can use straight-through cables for all network connections to PCs or servers, or to other switches or hubs. In straight-through cable, pins 1, 2, 3, and 6, at one end of the cable, are connected straight through to pins 1, 2, 3, and 6 at the other end of the cable. When using any RJ-45 port on these switches, you can use either straight-through or crossover cable.

**Table 15: 10/100BASE-TX MDI and MDI-X Port Pinouts**

Pin	MDI Signal Name	MDI-X Signal Name
1	Transmit Data plus (TD+)	Receive Data plus (RD+)
2	Transmit Data minus (TD-)	Receive Data minus (RD-)
3	Receive Data plus (RD+)	Transmit Data plus (TD+)
6	Receive Data minus (RD-)	Transmit Data minus (TD-)
4, 5, 7, 8	Not used	Not used



**NOTE:**

- The “+” and “-” signs represent the polarity of the wires that make up each wire pair.
- Auto-negotiation must be enabled for automatic MDI/MDI-X pinout configuration.

## Console Port Pin Assignment

The RJ-45 serial port on the front panel is used to connect to the switch for out-of-band console configuration. The on-board configuration program can be accessed from a terminal or a PC running a terminal emulation program.

The pin assignments used to connect to the serial port are provided in [Table 16](#).

**Table 16: Serial Cable Wiring**

RJ45	Pin	Usage
RTS	1	Used as defined. Should be connected
NC	2	Not used. Should not be connected
TXD	3	Used as defined. Should be connected
GND	4	Used as defined. Should be connected
GND	5	Used as defined. Should be connected
RXD	6	Used as defined. Should be connected
NC	7	Not used. Should not be connected
CTS	8	Used as defined. Should be connected

Console Port Pin Assignment

# Appendix C: Alarm Pin Assignments

---

This appendix contains pin assignments and includes the following sections:

- [Alarm Port Pin Assignments on page 86](#)

## Alarm Port Pin Assignments

The alarm interface port is a D-type 15-pin connector that supports a critical alarm output, a major alarm output, and four alarm inputs. When your system has a critical or major alarm, the CPU will drive the alarm relay to issue the alarm output and turn on the critical or major LED. If you push the alarm cut off (ACO) button, the relay will be released but the LED will stay on until the alarm is cleared.

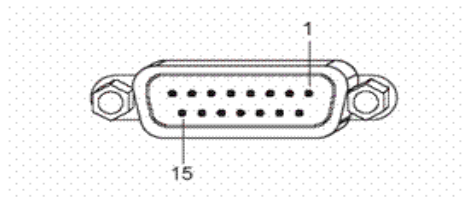

**Figure 14: DB-15 Alarm Connector**

The system signals the appropriate alarm output for the following events:

- Fan failure - Critical alarm is raised.
- One Power Supply Failure - Critical alarm is raised. The critical alarm is cleared and a major alarm is raised if the failed power supply is removed).
- Chassis temperature threshold exceeded - Major alarm is raised.

The system also supports four alarm inputs. The input voltage range is from 24V to 48V. If an alarm input is active, the CPU will process it, output it to the CLI, and issue an SNMP trap. An alarm input can also be configured to drive the appropriate alarm output pin. Please refer the System Basics user guide for more details on configuring the alarm inputs.

See [Table 17](#) for the alarm interface port pinouts.

**Table 17: Alarm Interface Port Pinouts**

Pin	Name	Function
1	CRIT_ALARM_CNTR	Common contact for Critical alarm relay.
2	CRIT_ALARM_NO	Normally open during Critical alarm state.
3	MJR_ALARM_NC	Normally closed during Major alarm state.
4	N/C	N/C

**Table 17: Alarm Interface Port Pinouts**

<b>Pin</b>	<b>Name</b>	<b>Function</b>
5	ALARM_IN4_EXT_+	External alarm input 4 (external relay dry contact closure to pin 12).
6	ALARM_IN3_EXT_+	External alarm input 3 (external relay dry contact closure to pin 13).
7	ALARM_IN2_EXT_+	External alarm input 2 (external relay dry contact closure to pin 14).
8	ALARM_IN1_EXT_+	External alarm input 1 (external relay dry contact closure to pin 15).
9	CRIT_ALARM_NC	Normally closed during Critical alarm state.
10	MJR_ALARM_CNTR	Common contact for Major alarm relay.
11	MJR_ALARM_NO	Normally open during Major alarm state.
12	ALARM_IN4_EXT_RTN	External alarm input 4 (external relay dry contact closure from pin 5).
13	ALARM_IN3_EXT_RTN	External alarm input 3 (external relay dry contact closure from pin 6).
14	ALARM_IN2_EXT_RTN	External alarm input 2 (external relay dry contact closure from pin 7).
15	ALARM_IN1_EXT_RTN	External alarm input 1 (external relay dry contact closure from pin 8).

## Alarm Port Pin Assignments

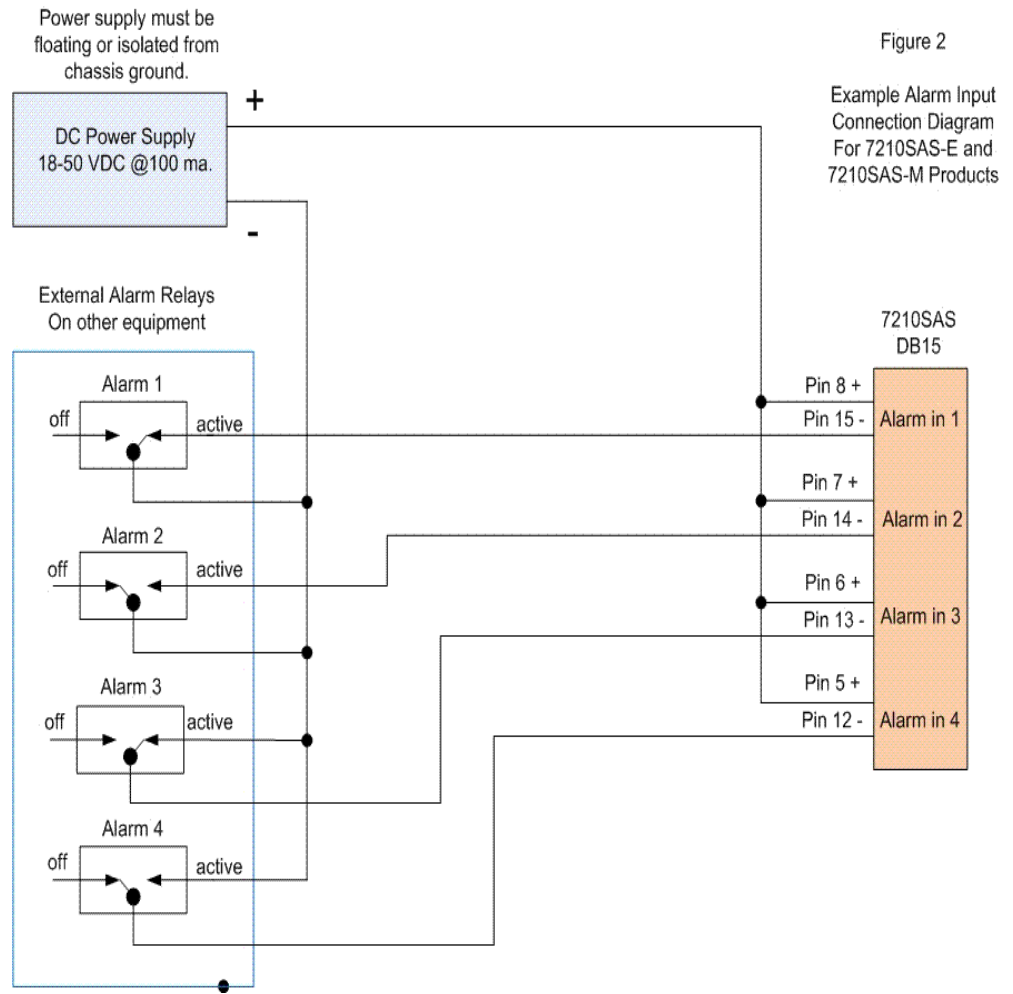

**Figure 15: Alarm Input Connection Diagram**

RTN refers to the negative side of the floating external power supply. This power supply must not be connected to chassis ground and should be 18-50 volts DC at 100 ma.

Major and Critical alarm dry relay contact outputs are provided on pins 3,10,11 and 1,2,9. These reflect the major and critical alarms output by the box and can be manually cleared by pressing the ACO button.

The 4 alarm inputs are customer configurable to monitor alarms provided by additional equipment. These inputs require a separate DC power supply between 18-



50 volts at 100ma. The power supply outputs must be isolated from chassis ground, for example do not connect the alarm power supply return to chassis or rack ground.

## Alarm Port Pin Assignments