



Alcatel-Lucent

Service Router | Release 12.0 R1
7950 SR-OS Interfaces Configuration Guide

93-0402-03-01 Edition 01
93-0402-03-01

Alcatel, Lucent, Alcatel-Lucent and the Alcatel-Lucent logo are trademarks of Alcatel-Lucent. All other trademarks are the property of their respective owners. The information presented is subject to change without notice. Alcatel-Lucent assumes no responsibility for inaccuracies contained herein. Copyright © 2014 Alcatel-Lucent. All Rights Reserved.



This document is protected by copyright. Except as specifically permitted herein, no portion of the provided information can be reproduced in any form, or by any means, without prior written permission from Alcatel-Lucent.
Alcatel, Lucent, Alcatel-Lucent and the Alcatel-Lucent logo are trademarks of Alcatel-Lucent. All other trademarks are the property of their respective owners.
The information presented is subject to change without notice.
Alcatel-Lucent assumes no responsibility for inaccuracies contained herein.

Copyright 2014 Alcatel-Lucent. All rights reserved.

TABLE OF CONTENTS

Getting Started

Alcatel-Lucent 7950 SR-Series Router Configuration Process	14
--	----

Interfaces

Configuration Overview	16
Chassis Slots and Cards	16
XMAx/C-XMAs	17
Digital Diagnostics Monitoring	19
Alcatel-Lucent SFPs and XFPs	25
Statistics Collection	25
Ports	26
Port Types	26
Port Features	28
Port State and Operational State	28
802.1x Network Access Control	30
SONET/SDH Port Attributes	36
SONET/ SDH Path Attributes	36
Ethernet Local Management Interface (E-LMI)	37
Link Layer Discovery Protocol (LLDP)	38
LAG	42
LACP	42
Active-Standby LAG Operation without LACP	42
LAG Subgroups on Access for DSLAM Aggregation	44
LAG on Access QoS Consideration	46
Adapt QoS Modes	46
Per-fp-ing-queuing	47
Per-fp-egr-queuing	48
Per-fp-sap-instance	49
LAG and ECMP Hashing	50
Per Flow Hashing	50
Per Link Hashing	56
Explicit Per Link Hash Using LAG Link Mapping Profiles	57
Consistent Per Service Hashing	58
ESM – LAG Hashing per Vport	60
LAG Hold Down Timers	63
BFD over LAG Links	64
Point-to-Point (p2p) Redundant Connection Across Layer 2/3 VPN Network	65
G.8032 Protected Ethernet Rings	67
802.3ah OAM	68
OAM Events	71
Remote Loopback	72
802.3ah OAM PDU Tunneling for Epipe Service	72
MTU Configuration Guidelines	73
Deploying Preprovisioned Components	76
Configuration Process Overview	77

Table of Contents

Configuration Notes	78
Configuring Physical Ports with CLI	79
Predefining Entities	79
Provisioning a Port	81
Maximizing Bandwidth Use	82
Basic Configuration	83
Common Configuration Tasks	84
Configuring XCMs (Cards) and XMAs (MDAs)	85
Configuring Forwarding Plane Parameters	86
Configuring XMA Access and Network Pool Parameters	87
Configuring Ports	88
Configuring Port Pool Parameters	88
Changing Hybrid-Buffer-Allocation	91
Configuring Ethernet Port Parameters	92
Ethernet Network Port	92
Ethernet Access Port	93
Configuring 802.1x Authentication Port Parameters	94
Configuring SONET/SDH Port Parameters	94
Configuring LAG Parameters	95
Configuring BFD on LAG Links	95
Service Management Tasks	97
Modifying or Deleting an XMA (MDA)	97
Modifying a Card Type	98
Deleting a Card	99
Deleting Port Parameters	99
XMA and Port Command Reference	101

LIST OF FIGURES

Interfaces

Figure 1:	802.1x Architecture	31
Figure 2:	802.1x Authentication Scenario	32
Figure 3:	802.1x EAPOL Timers (left) and RADIUS Timers (right)	34
Figure 4:	LLDP Internal Architecture for a Network Node	39
Figure 5:	Generic Customer Use Case For LLDP	40
Figure 6:	Active-Standby LAG Operation without LACP	43
Figure 7:	LAG on Access Interconnection	44
Figure 8:	LAG on Access Failure Switchover	44
Figure 9:	P2P Redundant Connection Through a Layer 2 VPN Network	65
Figure 10:	MTU Configuration Example	74
Figure 11:	Slot, XCM (card), XMA (mda), and Port Configuration and Implementation Flow	77

List of Tables

Getting Started

Table 1:	Configuration Process.....	14
----------	----------------------------	----

Interfaces

Table 1:	Real-Time DDM Information.....	22
Table 2:	DDM Alarms and Warnings.....	23
Table 3:	Relationship of Port State and Oper State.....	29
Table 4:	Adapt QoS Bandwidth/Rate Distribution.....	47
Table 5:	MTU Default Values.....	73
Table 6:	MTU Configuration Example Values.....	75

List of Tables

Preface

About This Guide

This guide describes system concepts and provides configuration examples to provision XMA Control Modules (XCMs), also referred to as cards, XRS Media Adapters (XMAs), and ports. This document is organized into functional chapters and provides concepts and descriptions of the implementation flow, as well as Command Line Interface (CLI) syntax and command usage.

Audience

This manual is intended for network administrators who are responsible for configuring the 7950 SR-Series routers. It is assumed that the network administrators have an understanding of networking principles and configurations, routing processes, and protocols and standards, including:

- CLI concepts
- XCM, XMA, and port configuration
- QoS policies
- Services

List of Technical Publications

The 7950 XSR documentation set is composed of the following books:

- **7950 SR OS Basic System Configuration Guide**
This guide describes basic system configurations and operations.
- **7950 SR OS System Management Guide**
This guide describes system security and access configurations as well as event logging and accounting logs.
- **7950 SR OS Interface Configuration Guide**
This guide describes XMA Control Module (XCM), XRS Media Adaptor (XMA), port and Link Aggregation Group (LAG) provisioning.
- **7950 SR OS Router Configuration Guide**
This guide describes logical IP routing interfaces and associated attributes such as an IP address, as well as IP and MAC-based filtering, and VRRP and Cflowd.
- **7950 SR OS Routing Protocols Guide**
This guide provides an overview of routing concepts and provides configuration examples for RIP, OSPF, IS-IS, BGP, and route policies.
- **7950 SRS MPLS Guide**
This guide describes how to configure Multiprotocol Label Switching (MPLS) and Label Distribution Protocol (LDP).
- **7950 SR OS Services Guide**
This guide describes how to configure service parameters such as service distribution points (SDPs), customer information, and user services.
- **7950 SR OAM and Diagnostic Guide**
- This guide describes how to configure features such as service mirroring and Operations, Administration and Management (OAM) tools.
- **7950 SR OS Quality of Service Guide**
This guide describes how to configure Quality of Service (QoS) policy management.

Technical Support

If you purchased a service agreement for your 7950 SR-Series router and related products from a distributor or authorized reseller, contact the technical support staff for that distributor or reseller for assistance. If you purchased an Alcatel-Lucent service agreement, contact your welcome center at:

<http://www.alcatel-lucent.com/wps/portal/support>

Report documentation errors, omissions and comments to:

ipd_online_feedback@alcatel-lucent.com

Include document name, version, part number and page(s) affected.

GETTING STARTED

In This Chapter

This chapter provides process flow information to configure XCMs (cards), XMAAs (mdas) and ports.

Alcatel-Lucent 7950 SR-Series Router Configuration Process

[Table 1](#) lists the tasks necessary to provision XMA Control Modules (XCMs), also referred to as cards, XRS Media Adaptors (XMAs), also referred to as MDAs, and ports.



NOTE: For consistency across platforms, XMAs are modelled in SR OS (CLI and SNMP) as MDAs (Media Dependant Adaptors).

This guide is presented in an overall logical configuration flow. Each section describes a software area and provides CLI syntax and command usage to configure parameters for a functional area.

Table 1: Configuration Process

Area	Task	Chapter
Provisioning	Chassis slots and cards	Chassis Slots and Cards on page 16
	XMAs	XMAx/C-XMAs on page 17
	Ports	Ports on page 26
Reference	List of IEEE, IETF, and other proprietary entities.	Standards and Protocol Support on page 741

In This Chapter

This chapter provides information about configuring chassis slots, cards, and ports. Topics in this chapter include:

- [Configuration Overview on page 16](#)
 - [Chassis Slots and Cards on page 16](#)
 - [XMAx/C-XMAs on page 17](#)
 - [Digital Diagnostics Monitoring on page 19](#)
 - [Ports on page 26](#)
 - [Port Types on page 26](#)
 - [Port Features on page 28](#)
 - [Link Layer Discovery Protocol \(LLDP\) on page 38](#)
 - [LAG on page 42](#)
 - [LAG on Access QoS Consideration on page 46](#)
 - [LAG and ECMP Hashing on page 50](#)
 - [LAG Hold Down Timers on page 63](#)
 - [BFD over LAG Links on page 64](#)
 - [LACP on page 42](#)
 - [Active-Standby LAG Operation without LACP on page 42](#)
 - [LAG on Access QoS Consideration on page 46](#)
 - [Multi-Chassis LAG on page 131](#)
 - [MTU Configuration Guidelines on page 73](#)
 - [Deploying Preprovisioned Components on page 76](#)
- [Configuration Process Overview on page 77](#)
- [Configuration Notes on page 78](#)

Configuration Overview

NOTE: This document uses the term provisioning in the context of preparing or preconfiguring entities such as chassis slots, cards, XCMs, XMA, ports, and interfaces, prior to initialization. These entities can be installed but not enabled. When the entity is in a no shutdown state (administratively enabled), then the entity is considered to be provisioned.

Alcatel-Lucent routers provide the capability to configure chassis slots to accept specific XCM (card) and XMA (mda) types and set the relevant configurations before the equipment is actually installed. The provisioning ability allows you to plan your configurations as well as monitor and manage your router hardware inventory. Ports and interfaces can also be provisioned. When the functionality is needed, the card(s) can be inserted into the appropriate chassis slots when required.

The following sections are discussed.

- [Chassis Slots and Cards on page 16](#)
 - [XMAx/C-XMAs on page 17](#)
 - [Ports on page 26](#)
-

Chassis Slots and Cards

To pre-provision a chassis slot, the XCM (card) type must be specified. System administrators or network operators can enter card type information for each slot, allowing a range of card types in particular slots. From the range of card types, a card and accompanying XCMs are specified. When a card is installed in a slot and enabled, the system verifies that the installed card type matches the allowed card type. If the parameters do not match, the card remains offline. A preprovisioned slot can remain empty without conflicting with populated slots.

7950 XRS systems accept XCMs (cards) and XMA (modelled as MDAs in CLI/SNMP). Refer to the appropriate system installation guide for more information.

XMAx/C-XMAs



NOTE: For consistency across platforms, XMAs are modelled in SR OS (CLI and SNMP) as MDAs (Media Dependant Adaptors). The term XMA in this document refers to either a C-XMA or an XMA unless otherwise stated.

A chassis slot and card type must be specified and provisioned before an XMA/MDA can be preprovisioned. An XMA/MDA is provisioned when a type designated from the allowed XMA/MDA types is inserted. A preprovisioned XMA/MDA slot can remain empty without conflicting with populated slots.

Once installed and enabled, the system verifies that the installed XMA/MDA type matches the configured parameters. If the parameters do not match, the XMA/MDA remains offline.

A chassis slot, card type must be specified and provisioned before an XMA/MDA can be preprovisioned. An XMA/MDA is provisioned when a type designated from the allowed XMA/MDA type is inserted. A preprovisioned XMA/MDA slot can remain empty without conflicting with populated slots.

XMA output displays an “x” in the name of the card, and a C-XMA displays a "cx". The following displays a show card state command.

```
A:Dut-A# show card state
```

```
=====
Card State
=====
Slot/   Provisioned Type           Admin Operational   Num   Num Comments
Id      Equipped Type (if different) State State           Ports MDA
-----
1       xcm-x20                    up    up                2
1/1    cx20-10g-sfp              up    up                20
1/2    cx20-10g-sfp              up    up                20
2       xcm-x20                    up    up                2
2/1    cx20-10g-sfp              up    up                20
A       cpm-x20                    up    up                Active
B       cpm-x20                    up    up                Standby
=====
```

Once installed and enabled, the system verifies that the installed XMA/MDA type matches the configured parameters. If the parameters do not match, the XMA/MDA remains offline.

Digital Diagnostics Monitoring

Some Alcatel-Lucent SFPs, XFPs, QSFPs, CFPs and the MSA DWDM transponder have Digital Diagnostics Monitoring (DDM) capability where the transceiver module maintains information about its working status in device registers including:

- Temperature
- Supply voltage
- Transmit (TX) bias current
- TX output power
- Received (RX) optical power

For the case of QSFP and CFPs, DDM Temperature and Supply voltage is available only at the Module level (to be shown in [Table 2](#)).

The section called [Statistics Collection on page 25](#) shows the following QSFP and CFP sample DDM and DDM Lane information:

The QSFP and CFPs, the number of lanes is indicated by DDM attribute “Number of Lanes : 4”.

Subsequently, each lane threshold and measured values are shown per lane.

If a given lane entry is not supported by the given QSFP or CFP specific model, then it will be shown as “-“ in the entry.

A sample QSFP and CFP lane information is provided below:

```

Transceiver Data
Transceiver Type      : QSFP+
Model Number         : 3HE06485AAAA01  ALU  IPUIBMY3AA
TX Laser Wavelength: 1310 nm
Number of Lanes      : 4
Connector Code       : LC
Vendor OUI           : e4:25:e9
Manufacture date     : 2012/02/02
Media                 : Ethernet
Serial Number        : 12050188
Part Number          : DF40GELR411102A
Optical Compliance   : 40GBASE-LR4
Link Length support  : 10km for SMF
=====
Transceiver Digital Diagnostic Monitoring (DDM)
=====
Value High Alarm  High Warn  Low Warn  Low Alarm
-----
Temperature (C)   +35.6     +75.0     +70.0     +0.0     -5.0
Supply Voltage (V) 3.23      3.60      3.50      3.10      3.00
=====
Transceiver Lane Digital Diagnostic Monitoring (DDM)
=====
High Alarm  High Warn  Low Warn  Low Alarm

```

Digital Diagnostics Monitoring

```

Lane Tx Bias Current (mA)          78.0          75.0          25.0          20.0
Lane Rx Optical Pwr (avg dBm)      2.30         2.00        -11.02        -13.01
-----
Lane ID Temp(C)/Alm              Tx Bias(mA)/Alm  Tx Pwr(dBm)/Alm  Rx Pwr(dBm)/Alm
-----
      1              -              43.5              -              0.42
      2              -              46.7              -              -0.38
      3              -              37.3              -              0.55
      4              -              42.0              -              -0.52
=====
Transceiver Type      : CFP
Model Number         : 3HE04821ABAA01  ALU  IPUIBHJDAA
TX Laser Wavelength: 1294 nm                               Diag Capable      : yes
Number of Lanes      : 4
Connector Code       : LC                               Vendor OUI         : 00:90:65
Manufacture date     : 2011/02/11                       Media              : Ethernet
Serial Number        : C22CQYR
Part Number          : FTLC1181RDNL-A5
Optical Compliance  : 100GBASE-LR4
Link Length support: 10km for SMF
=====
Transceiver Digital Diagnostic Monitoring (DDM)
=====
                                Value High Alarm  High Warn   Low Warn   Low Alarm
-----
Temperature (C)           +48.2      +70.0      +68.0      +2.0      +0.0
Supply Voltage (V)        3.24       3.46       3.43       3.17     3.13
=====
Transceiver Lane Digital Diagnostic Monitoring (DDM)
=====
                                High Alarm   High Warn   Low Warn   Low Alarm
-----
Lane Temperature (C)      +55.0      +53.0      +27.0      +25.0
Lane Tx Bias Current (mA) 120.0      115.0      35.0       30.0
Lane Tx Output Power (dBm) 4.50       4.00       -3.80      -4.30
Lane Rx Optical Pwr (avg dBm) 4.50       4.00      -13.00     -16.00
-----
Lane ID Temp(C)/Alm              Tx Bias(mA)/Alm  Tx Pwr(dBm)/Alm  Rx Pwr(dBm)/Alm
-----
      1          +47.6              59.2              0.30              -10.67
      2          +43.1              64.2              0.27              -10.31
      3          +47.7              56.2              0.38              -10.58
      4          +51.1              60.1              0.46              -10.37
=====

```

The transceiver is programmed with warning and alarm thresholds for low and high conditions that can generate system events. These thresholds are programmed by the transceiver manufacturer.

There are no CLI commands required for DDM operations, however, the **show>port port-id detail** command displays DDM information in the Transceiver Digital Diagnostics Monitoring output section.

DDM information is populated into the router's MIBs, so the DDM data can be retrieved by Network Management using SNMP. Also, RMON threshold monitoring can be configured for the

DDM MIB variables to set custom event thresholds if the factory-programmed thresholds are not at the desired levels.

The following are potential uses of the DDM data:

- Optics degradation monitoring — With the information returned by the DDM-capable optics module, degradation in optical performance can be monitored and trigger events based on custom or the factory-programmed warning and alarm thresholds.
- Link/router fault isolation — With the information returned by the DDM-capable optics module, any optical problem affecting a port can be quickly identified or eliminated as the potential problem source.

Supported real-time DDM features are summarized in [Table 1](#).

Table 1: Real-Time DDM Information

Parameter	User Units	SFP/XFP Units	SFP	XFP	MSA DWDM
Temperature	Celsius	C	Supported	Supported	Supported
Supply Voltage	Volts	μV	Supported	Supported	Not supported
TX Bias Current	mA	μA	Supported	Supported	Supported
TX Output Power	dBm (converted from mW)	mW	Supported	Supported	Supported
RX Received Optical Power4	dBm (converted from dBm) (Avg Rx Power or OMA)	mW	Supported	Supported	Supported
AUX1	parameter dependent (embedded in transceiver)	-	Not supported	Supported	Not supported
AUX2	parameter dependent (embedded in transceiver)	-	Not supported	Supported	Not supported

The factory-programmed DDM alarms and warnings that are supported are summarized in [Table 2](#).

Table 2: DDM Alarms and Warnings

Parameter	SFP/XFP Units	SFP	XFP	Required?	MSA DWDM
Temperature - High Alarm - Low Alarm - High Warning - Low Warning	C	Yes	Yes	Yes	Yes
Supply Voltage - High Alarm - Low Alarm - High Warning - Low Warning	μ V	Yes	Yes	Yes	No
TX Bias Current - High Alarm - Low Alarm - High Warning - Low Warning	μ A	Yes	Yes	Yes	Yes
TX Output Power - High Alarm - Low Alarm - High Warning - Low Warning	mW	Yes	Yes	Yes	Yes
RX Optical Power - High Alarm - Low Alarm - High Warning - Low Warning	mW	Yes	Yes	Yes	Yes
AUX1 - High Alarm - Low Alarm - High Warning - Low Warning	parameter dependent (embedded in transceiver)	No	Yes	Yes	No

Table 2: DDM Alarms and Warnings (Continued)

Parameter	SFP/XFP Units	SFP	XFP	Required?	MSA DWDM
AUX2 - High Alarm - Low Alarm - High Warning - Low Warning	parameter dependent (embedded in transceiver)	No	Yes	Yes	No

Alcatel-Lucent SFPs and XFPs

The availability of the DDM real-time information and warning/alarm status is based on the transceiver. It may or may not indicate that DDM is supported. Non-DDM and DDM-supported SFPs are distinguished by a specific ICS value.

For Alcatel-Lucent SFPs that do not indicate DDM support in the ICS value, DDM data is available although the accuracy of the information has not been validated or verified.

For non-Alcatel-Lucent transceivers, DDM information may be displayed, but Alcatel-Lucent is not responsible for formatting, accuracy, etc.

Statistics Collection

The DDM information and warnings/alarms are collected at one minute intervals, so the minimum resolution for any DDM events when correlating with other system events is one minute.

Note that in the Transceiver Digital Diagnostic Monitoring section of the **show port *port-id* detail** command output:

- If the present measured value is higher than the either or both High Alarm, High Warn thresholds; an exclamation mark “!” displays along with the threshold value.
- If the present measured value is lower than the either or both Low Alarm, Low Warn thresholds; an exclamation mark “!” displays along with the threshold value.

```
B:SR7-101# show port 2/1/6 detail
.....
=====
Transceiver Digital Diagnostic Monitoring (DDM), Internally Calibrated
=====
                Value High Alarm  High Warn   Low Warn  Low Alarm
-----
Temperature (C)      +33.0+98.0  +88.0      -43.0-45.0
Supply Voltage (V)    3.31 4.12   3.60       3.00 2.80
Tx Bias Current (mA) 5.7 60.0   50.00.1  0.0
Tx Output Power (dBm) -5.45 0.00  -2.00     -10.50  -12.50
Rx Optical Power (avg dBm) -0.65-3.00! -4.00!    -19.51  -20.51
=====
```

Ports

Port Types

Before a port can be configured, the slot must be provisioned with an XCM (card) type and XMA (mda) type.

The Alcatel-Lucent routers support the following port types:

- Ethernet — For example 10Gigabit Ethernet or 100G Ethernet

Router ports must be configured as either access, hybrid or network. The default is network.

- Access ports — Configured for customer facing traffic on which services are configured. If a Service Access Port (SAP) is to be configured on the port or channel, it must be configured as an access port or channel. When a port is configured for access mode, the appropriate encapsulation type must be configured to distinguish the services on the port or channel. Once a port has been configured for access mode, one or more services can be configured on the port or channel depending on the encapsulation value.
- Network ports — Configured for network facing traffic. These ports participate in the service provider transport or infrastructure network. Dot1q is supported on network ports.
- Hybrid ports — Configured for access and network facing traffic. While the default mode of an Ethernet port remains network, the mode of a port cannot be changed between the access/network/hybrid values unless the port is shut down and the configured SAPs and/or interfaces are deleted. Hybrid ports allow a single port to operate in both access and network modes. MTU of port in hybrid mode is the same as in network mode. The default encap for hybrid port mode is dot1q; it also supports QinQ encapsulation on the port level. Null hybrid port mode is not supported.

Once the port is changed to hybrid, the default MTU of the port is changed to match the value of 9212 bytes currently used in network mode (higher than an access port); this is to ensure that both SAP and network VLANs can be accommodated. The configuration of all parameters in access and network contexts will continue to be done within the port using the same CLI hierarchy as in existing implementation. The difference is that a port configured in mode hybrid allows both ingress and egress contexts to be configured concurrently.

An Ethernet port configured in hybrid mode can have two values of encapsulation type: dot1q and QinQ. The NULL value is not supported since a single SAP is allowed, and can be achieved by configuring the port in the access mode, or a single network IP interface is allowed, which can be achieved by configuring the port in network mode. Hybrid mode can be enabled on a LAG port when the port is part of a

single chassis LAG configuration. When the port is part of a multi-chassis LAG configuration, it can only be configured to access mode since MC-LAG is not supported on a network port and consequently is not supported on a hybrid port. The same restriction applies to a port that is part of an MC-Ring configuration.

For a hybrid port, the amount of the allocated port buffers in each of ingress and egress is split equally between network and access contexts using the following **config>port>hybrid-buffer-allocation>ing-weight access access-weight [0..100] network network-weight [0..100]** and **config>port>hybrid-buffer-allocation>egr-weight access access-weight [0..100] network network-weight [0..100]** commands.

Adapting the terminology in buffer-pools, the port's access active bandwidth and network active bandwidth in each ingress and egress are derived as follows (egress formulas shown only):

- $\text{total-hybrid-port-egress-weights} = \text{access-weight} + \text{network-weight}$
- $\text{hybrid-port-access-egress-factor} = \text{access-weight} / \text{total-hybrid-port-egress-weights}$
- $\text{hybrid-port-network-egress-factor} = \text{network-weight} / \text{total-hybrid-port-egress-weights}$
- $\text{port-access-active-egress-bandwidth} = \text{port-active-egress-bandwidth} \times \text{hybrid-port-access-egress-factor}$
- $\text{port-network-active-egress-bandwidth} = \text{port-active-egress-bandwidth} \times \text{hybrid-port-network-egress-factor}$

When a named pool policy is applied to the hybrid port's MDA or to the hybrid port, the port's fair share of total buffers available to the MDA is split into three parts: default pools, named pools local to the port, and named pools on the ports MDA. This allocation can be altered by entering the corresponding values in the **port-allocation-weights** parameter.

- WAN PHY— 10G ethernet ports can be configured in WAN PHY mode (using the ethernet xgig config). When configuring the port to be in WAN mode, you can change certain SONET/SDH parameters to reflect the SONET/SDH requirements for this port.

Port Features

- [Port State and Operational State on page 28](#)
 - [802.1x Network Access Control on page 30](#)
 - [SONET/SDH Port Attributes on page 36](#)
 - [SONET/ SDH Path Attributes on page 36](#)
-

Port State and Operational State

There are two port attributes that are related and similar but have slightly different meanings: Port State and Operational State (or Operational Status).

The following descriptions are based on normal individual ports.

- Port State
 - Displayed in port summaries such as **show port** or **show port 1/1**
 - `tmnxPortState` in the TIMETRA-PORT-MIB
 - Values: None, Ghost, Down (linkDown), Link Up, Up
- Operational State
 - Displayed in the show output of a specific port such as **show port 2/1/3**
 - `tmnxPortOperStatus` in the TIMETRA-PORT-MIB
 - Values: Up (inService), Down (outOfService)

The behavior of Port State and Operational State are different for a port with link protocols configured (Eth OAM, Eth CFM or LACP for ethernet ports, LCP for PPP/POS ports). A port with link protocols configured will only transition to the **Up** Port State when the physical link is up and all the configured protocols are up. A port with no link protocols configured will transition from Down to Link Up and then to Up immediately once the physical link layer is up.

The SR-OS linkDown and linkUp log events (events 2004 and 2005 in the snmp application group) are associated with transitions of the port Operational State. Note that these events map to the RFC 2863, *The Interfaces Group MIB*, (which obsoletes RFC 2233, *The Interfaces Group MIB using SMIPv2*) linkDown and linkUp traps as mentioned in the SNMPv2-MIB.

An Operational State of **Up** indicates that the port is ready to transmit service traffic (the port is physically up and any configured link protocols are up). The relationship between port Operational State and Port State in SR-OS is shown in the following table:

Table 3: Relationship of Port State and Oper State

	Operational State (Oper State or Oper Status) (as displayed in “show port x/y/z”)	
Port State (as displayed in the show port summary)	For ports that have no link layer protocols configured	For ports that have link layer protocols configured (PPP, LACP, 802.3ah EFM, 802.1ag Eth-CFM)
Up	Up	Up
Link Up (indicates the physical link is ready)	Up	Down
Down	Down	Down

802.1x Network Access Control

The Alcatel-Lucent 7950 SR supports network access control of client devices (PCs, STBs, etc.) on an Ethernet network using the IEEE. 802.1x standard. 802.1x is known as Extensible Authentication Protocol (EAP) over a LAN network or EAPOL.

802.1x Modes

The Alcatel-Lucent 7950 SR supports port-based network access control for Ethernet ports only. Every Ethernet port can be configured to operate in one of three different operation modes, controlled by the port-control parameter:

- **force-auth** — Disables 802.1x authentication and causes the port to transition to the authorized state without requiring any authentication exchange. The port transmits and receives normal traffic without requiring 802.1x-based host authentication. This is the default setting.
- **force-unauth** — Causes the port to remain in the unauthorized state, ignoring all attempts by the hosts to authenticate. The switch cannot provide authentication services to the host through the interface.
- **auto** — Enables 802.1x authentication. The port starts in the unauthorized state, allowing only EAPOL frames to be sent and received through the port. Both the router and the host can initiate an authentication procedure as described below. The port will remain in unauthorized state (no traffic except EAPOL frames is allowed) until the first client is authenticated successfully. After this, traffic is allowed on the port for all connected hosts.

802.1x Basics

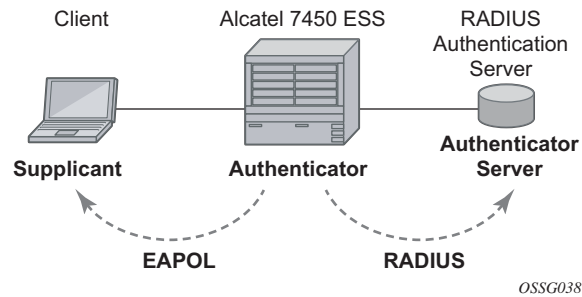
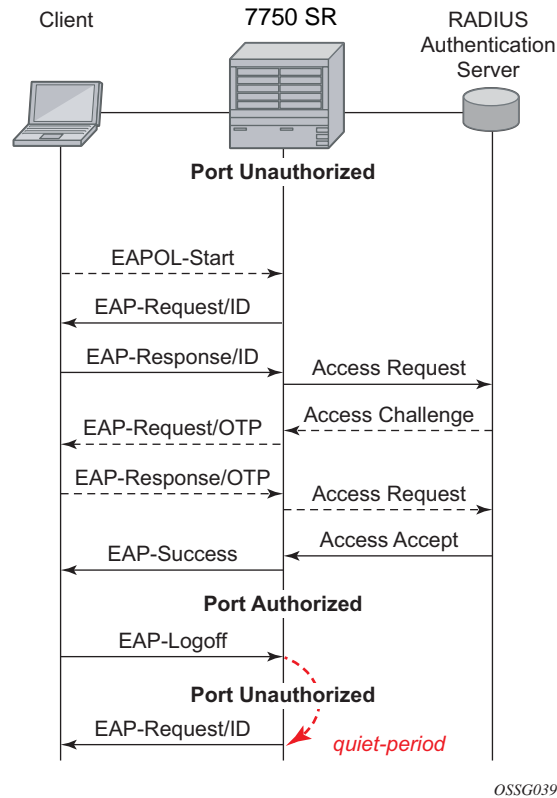

Figure 1: 802.1x Architecture

The IEEE 802.1x standard defines three participants in an authentication conversation (see [Figure 1](#)).

- The supplicant — This is the end-user device that requests access to the network.
- The authenticator — Controls access to the network. Both the supplicant and the authenticator are referred to as Port Authentication Entities (PAEs).
- The authentication server — Performs the actual processing of the user information.

The authentication exchange is carried out between the supplicant and the authentication server, the authenticator acts only as a bridge. The communication between the supplicant and the authenticator is done through the Extended Authentication Protocol (EAP) over LANs (EAPOL). On the back end, the communication between the authenticator and the authentication server is done with the RADIUS protocol. The authenticator is thus a RADIUS client, and the authentication server a RADIUS server.



OSSG039

Figure 2: 802.1x Authentication Scenario

The messages involved in the authentication procedure are illustrated in [Figure 2](#). The router will initiate the procedure when the Ethernet port becomes operationally up, by sending a special PDU called EAP-Request/ID to the client. The client can also initiate the exchange by sending an EAPOL-start PDU, if it doesn't receive the EAP-Request/ID frame during bootup. The client responds on the EAP-Request/ID with a EAP-Response/ID frame, containing its identity (typically username + password).

After receiving the EAP-Response/ID frame, the router will encapsulate the identity information into a RADIUS AccessRequest packet, and send it off to the configured RADIUS server.

The RADIUS server checks the supplied credentials, and if approved will return an Access Accept message to the router. The router notifies the client with an EAP-Success PDU and puts the port in authorized state.

802.1x Timers

The 802.1x authentication procedure is controlled by a number of configurable timers and scalars. There are two separate sets, one for the EAPOL message exchange and one for the RADIUS message exchange. See [Figure 3](#) for an example of the timers.

EAPOL timers:

- *transit-period* — Indicates how many seconds the Authenticator will listen for an EAP-Response/ID frame. If the timer expires, a new EAP-Request/ID frame will be sent and the timer restarted. The default value is 60. The range is 1-3600 seconds.
- *supplicant-timeout* — This timer is started at the beginning of a new authentication procedure (transmission of first EAP-Request/ID frame). If the timer expires before an EAP-Response/ID frame is received, the 802.1x authentication session is considered as having failed. The default value is 30. The range is 1 — 300.
- *quiet-period* — Indicates number of seconds between authentication sessions It is started after logoff, after sending an EAP-Failure message or after expiry of the supplicant-timeout timer. The default value is 60. The range is 1 — 3600.

RADIUS timer and scalar:

- *max-auth-req* — Indicates the maximum number of times that the router will send an authentication request to the RADIUS server before the procedure is considered as having failed. The default value is value 2. The range is 1 — 10.
- *server-timeout* — Indicates how many seconds the authenticator will wait for a RADIUS response message. If the timer expires, the access request message is sent again, up to *max-auth-req* times. The default value is 60. The range is 1 — 3600 seconds.

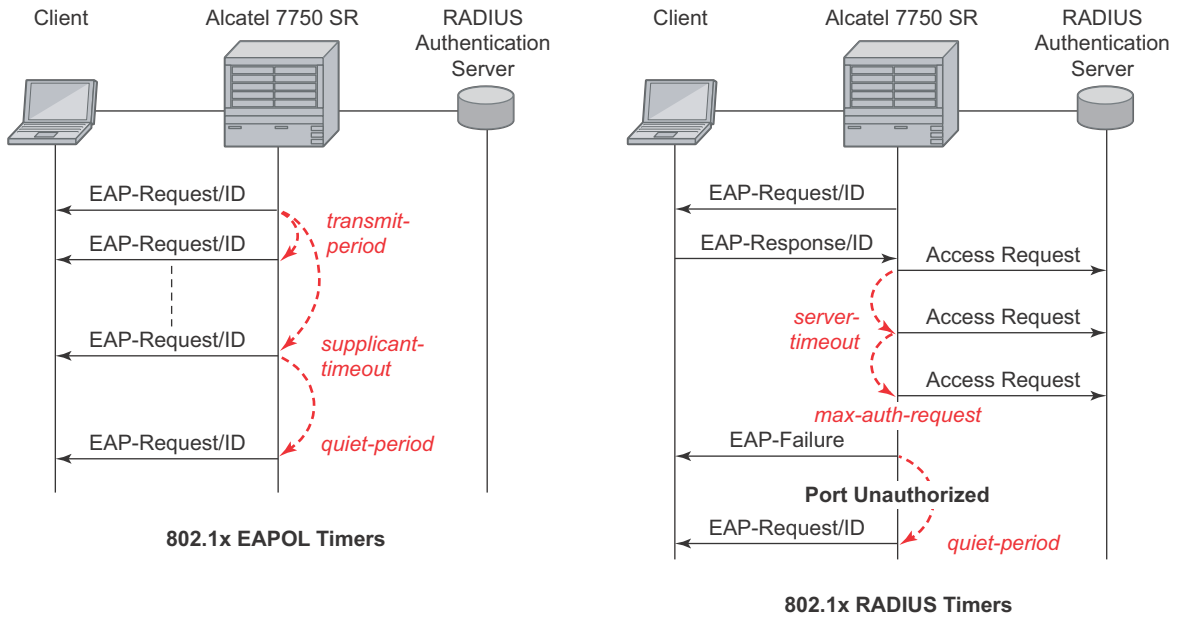

OSSG040-7750

Figure 3: 802.1x EAPOL Timers (left) and RADIUS Timers (right)

The router can also be configured to periodically trigger the authentication procedure automatically. This is controlled by the `enable re-authentication` and `reauth-period` parameters. `Reauth-period` indicates the period in seconds (since the last time that the authorization state was confirmed) before a new authentication procedure is started. The range of `reauth-period` is 1 — 9000 seconds (the default is 3600 seconds, one hour). Note that the port stays in an authorized state during the re-authentication procedure.

802.1x Tunneling

Tunneling of untagged 802.1x frames received on a port is supported for both Epipe and VPLS service using either null or default SAPs (for example 1/1/1:*) when the port dot1x port-control is set to force-auth.

When tunneling is enabled on a port (using the command configure **port *port-id* ethernet dot1x tunneling**), untagged 802.1x frames are treated like user frames and are switched into Epipe or VPLS services which have a corresponding null SAP or default SAP on that port. In the case of a default SAP, it is possible that other non-default SAPs are also present on the port. Untagged 802.1x frames received on other service types, or on network ports, are dropped. This is supported on FP2 or higher hardware.

When tunneling is required, it is expected that it is enabled on all ports into which 802.1x frames are to be received. The configuration of dot1x must be configured consistently across all ports in LAG as this is not enforced by the system.

Note that 802.1x frames are treated like user frames, that is, tunneled, by default when received on a spoke or mesh SDP.

802.1x Configuration and Limitations

Configuration of 802.1x network access control on the router consists of two parts:

- Generic parameters, which are configured under **config>security>dot1x**
- Port-specific parameters, which are configured under **config>port>ethernet>dot1x**

801.x authentication:

- Provides access to the port for any device, even if only a single client has been authenticated.
- Can only be used to gain access to a pre-defined Service Access Point (SAP). It is not possible to dynamically select a service (such as a VPLS service) depending on the 802.1x authentication information.

SONET/SDH Port Attributes

When an ethernet port is configured in WAN mode (xgig wan), you can change certain SONET/SDH parameters to reflect the SONET/SDH requirements for this port. See [SONET/SDH Port Commands on page 196](#) for details.

SONET/ SDH Path Attributes

When an ethernet port is configured in WAN mode (xgig wan), you can change certain SONET/SDH parameters to reflect the SONET/SDH requirements for this port. See [SONET/SDH Path Commands on page 200](#) for details.

Ethernet Local Management Interface (E-LMI)

The Ethernet Local Management Interface (E-LMI) protocol is defined in Metro Ethernet Forum (MEF) technical specification MEF16. This specification largely based on Frame Relay - LMI defines the protocol and procedures that convey the information for auto-configuration of a CE device and provides the means for EVC status notification. MEF16 does not include link management functions like Frame Relay LMI does. In the Ethernet context that role is already accomplished with Clause 57 Ethernet OAM (formerly 802.3ah).

The SR OS currently implements the User Network Interface-Network (UNI-N) functions for status notification supported on Ethernet access ports with dot1q encapsulation type. Notification related to status change of the EVC and CE-VLAN ID to EVC mapping information is provided as a one to one between SAP and EVC.

The E-LMI frame encapsulation is based on IEEE 802.3 untagged MAC frame format using an ether-type of 0x88EE. The destination MAC address of the packet 01-80-C2-00-00-07 will be dropped by any 802.1d compliant bridge that does not support or have the E-LMI protocol enabled. This means the protocol cannot be tunneled.

Status information is sent from the UNI-N to the UNI-C, either because a status enquiry was received from the UNI-C or unsolicited. The Active and Not Active EVC status are supported. The Partially Active state is left for further study.

The bandwidth profile sub-information element associated with the EVC Status IE does not use information from the SAP QoS policy. A value of 0 is used in this release as MEF 16 indicates the bandwidth profile sub-IE is mandatory in the EVC Status IE. The EVC identifier is set to the description of the SAP and the UNI identifier is set to the description configured on the port. Further, the implementation associates each SAP with an EVC. Currently, support exists for CE-VLAN ID/EVC bundling mode.

As stated in the OAM Mapping section in the OAM and Diagnostics Guide, E-LMI the UNI-N can participate in the OAM fault propagation functions. This is a unidirectional update from the UNI-N to the UNI-C and interacting with service manager of VLL, VPLS, VPRN and IES services.

Link Layer Discovery Protocol (LLDP)

The IEEE 802.1ab Link Layer Discovery Protocol (LLDP) standard defines protocol and management elements that are suitable for advertising information to stations attached to the same IEEE 802 LAN (emulation) for the purpose of populating physical or logical topology and device discovery management information databases. The protocol facilitates the identification of stations connected by IEEE 802 LANs/MANs, their points of interconnection, and access points for management protocols.

Note that LAN emulation and logical topology wording is applicable to customer bridge scenarios (enterprise/carrier of carrier) connected to a provider network offering a transparent LAN emulation service to their customers. It helps the customer bridges detect misconnection by an intermediate provider by offering a view of the customer topology where the provider service is represented as a LAN interconnecting these customer bridges.

The IEEE 802.1ab standard defines a protocol that:

- Advertises connectivity and management information about the local station to adjacent stations on the same IEEE 802 LAN.
- Receives network management information from adjacent stations on the same IEEE 802 LAN.
- Operates with all IEEE 802 access protocols and network media.
- Establishes a network management information schema and object definitions that are suitable for storing connection information about adjacent stations.
- Provides compatibility with a number of MIBs as depicted in [Figure 4](#).

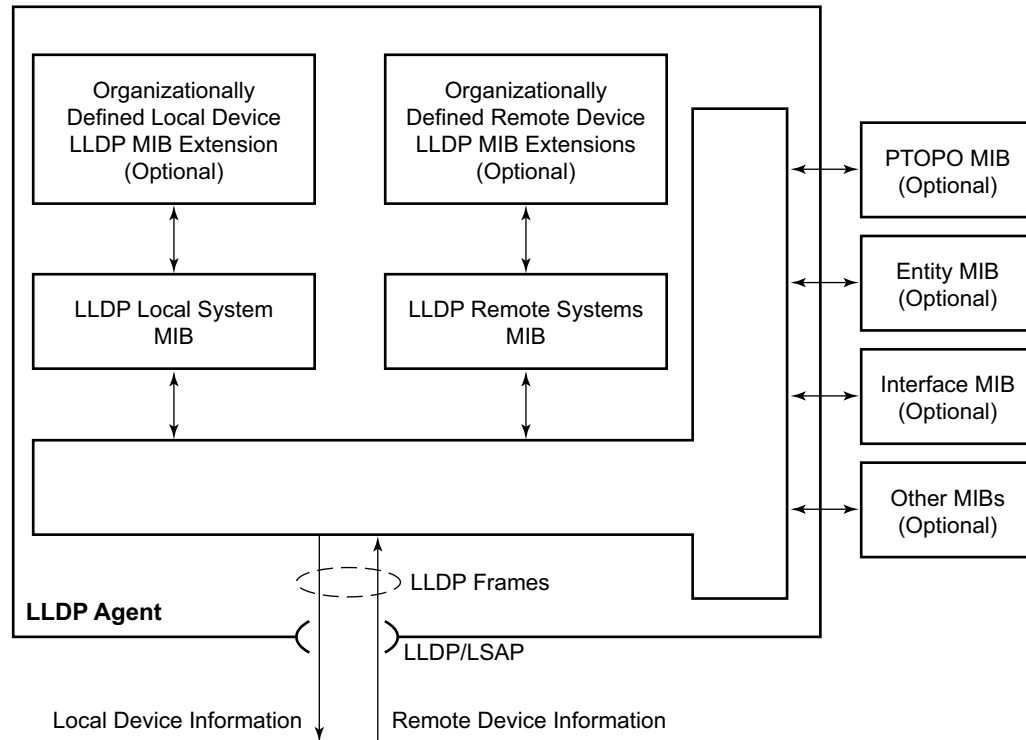

OSSG262

Figure 4: LLDP Internal Architecture for a Network Node

Network operators must be able to discover the topology information in order to detect and address network problems and inconsistencies in the configuration. Moreover, standard-based tools can address the complex network scenarios where multiple devices from different vendors are interconnected using Ethernet interfaces.

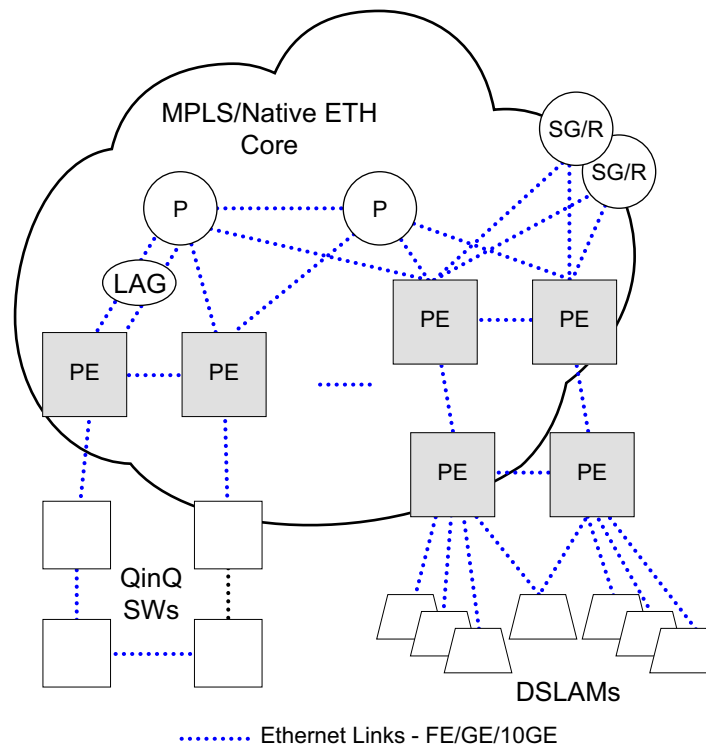

OSSG263

Figure 5: Generic Customer Use Case For LLDP

The example displayed in [Figure 5](#) depicts a MPLS network that uses Ethernet interfaces in the core or as an access/handoff interfaces to connect to different kind of Ethernet enabled devices such as service gateway/routers, QinQ switches, DSLAMs or customer equipment.

IEEE 802.1ab LLDP running on each Ethernet interfaces in between all the above network elements may be used to discover the topology information.

LLDP Protocol Features

LLDP is an unidirectional protocol that uses the MAC layer to transmit specific information related to the capabilities and status of the local device. Separately from the transmit direction, the LLDP agent can also receive the same kind of information for a remote device which is stored in the related MIB(s).

LLDP itself does not contain a mechanism for soliciting specific information from other LLDP agents, nor does it provide a specific means of confirming the receipt of information. LLDP allows the transmitter and the receiver to be separately enabled, making it possible to configure an implementation so the local LLDP agent can either transmit only or receive only, or can transmit and receive LLDP information.

The information fields in each LLDP frame are contained in a LLDP Data Unit (LLDPDU) as a sequence of variable length information elements, that each include type, length, and value fields (known as TLVs), where:

- Type identifies what kind of information is being sent.
- Length indicates the length of the information string in octets.
- Value is the actual information that needs to be sent (for example, a binary bit map or an alphanumeric string that can contain one or more fields).

Each LLDPDU contains four mandatory TLVs and can contain optional TLVs as selected by network management:

- Chassis ID TLV
- Port ID TLV
- Time To Live TLV
- Zero or more optional TLVs, as allowed by the maximum size of the LLDPDU
- End Of LLDPDU TLV

The chassis ID and the port ID values are concatenated to form a logical identifier that is used by the recipient to identify the sending LLDP agent/port. Both the chassis ID and port ID values can be defined in a number of convenient forms. Once selected however, the chassis ID/port ID value combination remains the same as long as the particular port remains operable.

A non-zero value in the TTL field of the Time To Live TLV tells the receiving LLDP agent how long all information pertaining to this LLDPDU's identifier will be valid so that all the associated information can later be automatically discarded by the receiving LLDP agent if the sender fails to update it in a timely manner. A zero value indicates that any information pertaining to this LLDPDU's identifier is to be discarded immediately.

Note that a TTL value of zero can be used, for example, to signal that the sending port has initiated a port shutdown procedure. The End Of LLDPDU TLV marks the end of the LLDPDU.

LAG

Based on the IEEE 802.1ax standard (formerly 802.3ad), Link Aggregation Groups (LAGs) can be configured to increase the bandwidth available between two network devices, depending on the number of links installed. LAG also provides redundancy in the event that one or more links participating in the LAG fail. All physical links in a given LAG links combine to form one logical interface.

Packet sequencing must be maintained for any given session. The hashing algorithm deployed by Alcatel-Lucent routers is based on the type of traffic transported to ensure that all traffic in a flow remains in sequence while providing effective load sharing across the links in the LAG.

LAGs must be statically configured or formed dynamically with Link Aggregation Control Protocol (LACP). The optional marker protocol described in IEEE 802.3ax is not implemented. LAGs can be configured on network and access ports.

The LAG load sharing is executed in hardware, which provides line rate forwarding for all port types.

LACP

Generally, link aggregation is used for two purposes: provide an increase in bandwidth and/or provide redundancy. Both aspects are addressed by aggregating several Ethernet links in a single LAG.

Under normal operation, all non-failing links in a given LAG will become active and traffic is load balanced across all active links. In some circumstances, however, this is not desirable. Instead, it desired that only some of the links are active (for example, all links on the same IOM) and the other links be kept in stand-by condition.

LACP enhancements allow active lag-member selection based on particular constrains. The mechanism is based on the IEEE 802.3ax standard so interoperability is ensured.

Active-Standby LAG Operation without LACP

Active/standby LAG is used to provide redundancy while keeping consistency of H-QOS enforcement. Some devices do not support LACP and hence an alternative solution is required.

The active/standby decision for LAG member links is local decision driven by pre-configured selection-criteria. This decision was communicated to remote system using LACP signalling.

As an alternative, the operator can **disable-transmitter** at the port member level. As a consequence, the transmit laser will be switched off for all LAG members in standby mode. On switch over (active-links failed) the laser will be switched on all LAG members will become active.

When LACP goes down on a standby link, a warning message announcing that LACP has expired on the corresponding member port is printed in log 99 on the other end. In the following example, port 1/1/9 is a member of standby-lag-group.

```
*A:sr7- show log log-id 99
=====
Event Log 99
=====
Description : Default System Log
Memory Log contents [size=500  next event=7  (not wrapped)]
6 2000/01/22 20:30:57.72 UTC WARNING: LAG2006 Base LAG
"LAG 10 : LACP expired on member 1/1/9"
```

The operation where standby ports are powered down is mutually exclusive with LACP and, therefore, is modelled as separate mode of LACP operation of **power-off**. For this mode, the selection-criteria **best-port** can be used. This criteria means that it will be always a sub-group with the **test-port** (the highest priority port) which will be chosen to be used as active sub-group.

It will not be possible to have an active LACP in power-off mode before the correct selection criteria is selected.

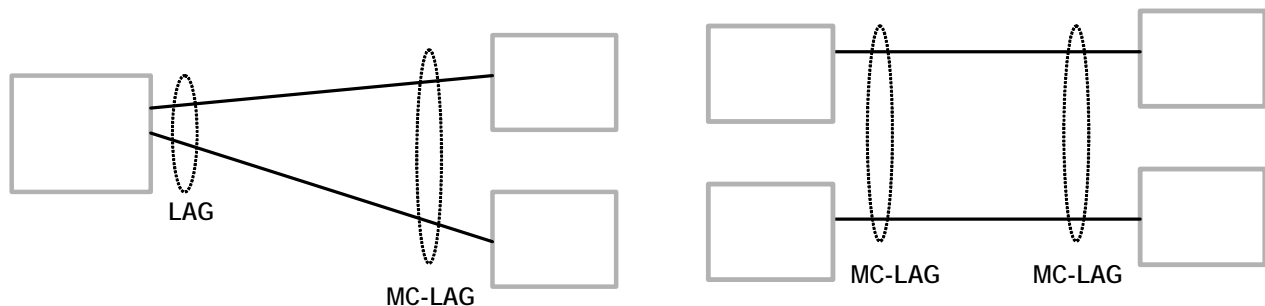
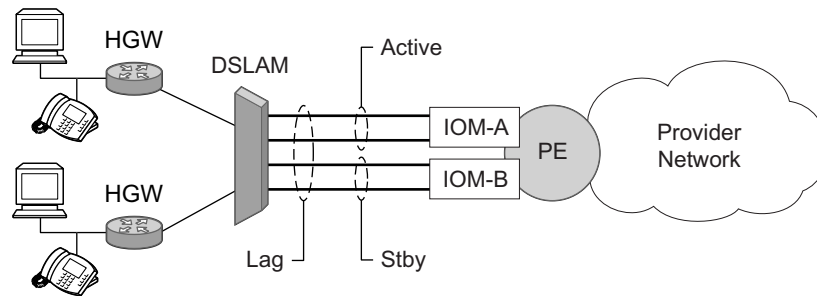

Figure 6: Active-Standby LAG Operation without LACP

LAG Subgroups on Access for DSLAM Aggregation

At the same time, QoS SLA enforcement is required. Enforcing QoS policies across links attached to different IOMs is not possible and therefore it is desirable that traffic always flows through a single IOM. This can be achieved by selecting only links of a single IOM as active LAG members and keeping all other LAG members in stand-by condition.

In case of a link failure, [Figure 7](#) and [Figure 8](#), the switch over mechanism must take into account the above QoS restriction. This means that all lag-members connected to the same IOM as failing link will become stand-by and lag-members connected to other IOM will become active. This way, QoS enforcement constraints are respected, while the maximum of available links is utilized.



OSSG095

Figure 7: LAG on Access Interconnection

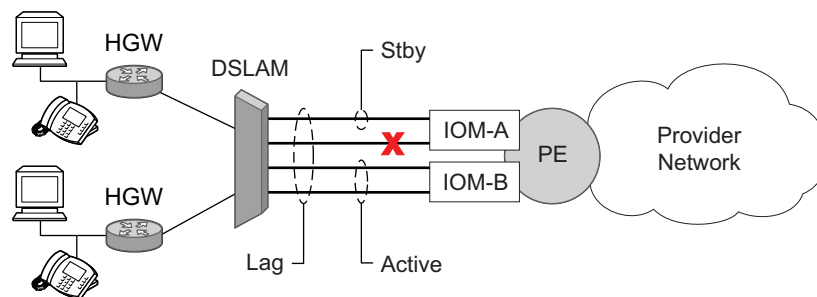

Figure 8: LAG on Access Failure Switchover

LACP is used to make selection of active links predictable and compatible with any vendor equipment. Refer to the IEEE STD 802.3-2002, Section 3, Clause 43.6.1 standard which describes how LACP allows stand-by and active signalling.

The system implementation of LACP supports the following:

- A given LAG member can be assigned to sub-groups. The selection algorithm then assures that only members of a single sub-group are selected as active links.
- The selection algorithm is effective only if LACP is enabled on a given LAG. At the same time, it is assumed that connected system has also LACP enabled (active or passive mode).
- The algorithm will select active links based on following criteria:
 - Depending on selection-criteria setting either the sub-group with the highest number of eligible links or the sub-group with the highest aggregate weight of all eligible members is selected first.
 - If multiple groups satisfy the selection criteria, the sub-group being currently active remains active. Initially, the sub-group containing the highest priority eligible link is selected.
 - Only links pertaining to a single sub-group are active at any time.
 - An eligible member refers to a LAG member link which can potentially become active. This means it is operationally up, and if the slave-to-partner flag is set, the remote system did not disable its use (by signalling stand-by).
- The selection algorithm works in a reverting mode. This means that every time the configuration or status of any link in a LAG changes, the selection algorithm is re-run. In case of a tie between two groups (one of them being currently active) the active group remains active (no reverting).

LAG on Access QoS Consideration

The following section describes various QoS related features applicable to LAG on access.

Adapt QoS Modes

Link Aggregation is supported on access side with access/hybrid ports. Similarly to LAG on network side, LAG on access is used to aggregate Ethernet ports into all active or active/standby LAG. The difference with LAG on networks lies in how the QoS/H-QoS is handled. Based on hashing configured, a given SAP's traffic can be sprayed on egress over multiple LAG ports or can always use a single port of a LAG. There are three user-selectable modes that allow operator to best adapt QoS configured to a LAG the SAPs are using:

1. adapt-qos distributed (default)

In a distributed mode the SLA is divided among all line cards proportionally to the number of ports that exist on that line card for a given LAG. For example a 100Mb PIR with 2 LAG links on IOM A and 3 LAG links on IOM B would result in IOM A getting 40 Mb PIR and IOM B getting 60M PIR. Thanks to such distribution, SLA can be enforced. The disadvantage is that a single flow is limited to IOM's share of the SLA. This mode of operation may also result in underrun due to a "hash error" (traffic not sprayed equally over each link). This mode is best suited for services that spray traffic over all links of a LAG.

2. adapt-qos link

In a link mode the SLA is given to each and every port of a LAG. With the example above, each port would get 100 Mbps PIR. The advantage of this method is that a single flow can now achieve the full SLA. The disadvantage is that the overall SLA can be exceeded, if the flows span multiple ports. This mode is best suited for services that are guaranteed to hash to a single egress port.

3. adapt-qos distributed include-egr-hash-cfg

This mode can be considered a mix of link and distributed mode. The mode uses the configured hashing for LAG/SAP/service to choose either link or distributed adapt-qos modes. The mode allows:

- SLA enforcement for SAPs that through configuration are guaranteed to hash to a single egress link using full QoS per port (as per link mode)
- SLA enforcement for SAPs that hash to all LAG links proportional distribution of QoS SLA amongst the line cards (as per distributed mode)
- SLA enforcement for multi service sites (MSS) that contain any SAPs regardless of their hash configuration using proportional distribution of QoS SLA amongst the line cards (as per distributed mode)

The following caveats apply to `adapt-qos distributed include-egr-hash-cfg`,

- The feature requires chassis mode D.
- LAG mode must be access or hybrid.
- The operator cannot change from **adapt-qos distribute include-egr-hash-cfg** to **adapt-qos distribute** when `link-map-profiles` or `per-link-hash` is configured.
- The operator cannot change from **adapt-qos link** to **adapt-qos distribute include-egr-hash-cfg** on a LAG with any configuration.
- Platforms supported except 7710 c12/c4, 7750 SR-1, 7450 ESS-1

Table 4 shows examples of rate/BW distributions based on the **adapt-qos** mode used:

Table 4: Adapt QoS Bandwidth/Rate Distribution

	link	distribute	distribute include-egr-hash-cfg
SAP Queues	100% rate	% # local links*	100% rate (SAP hash to one link) or % # local links* (SAP hash to all links)
SAP Scheduler	100% bandwidth	% # local links*	100% bandwidth (SAP hash to a one link) or % # local links* (SAP hash to all links)
SAP MSS Scheduler	100% bandwidth	% # local links*	% # local links*

* % # local links = X * (number of local LAG members on a given line card/ total number of LAG members)

Per-fp-ing-queuing

Per-fp-ing-queuing optimization for LAG ports provides the ability to reduce the number of hardware queues assigned on each LAG SAP on ingress when the flag at LAG level is set for per-fp-ing-queuing.

When the feature is enabled in the `config>lag>access` context, the queue allocation for SAPs on a LAG will be optimized and only one queuing set per ingress forwarding path (FP) is allocated instead of one per port.

The following rules will apply for configuring the per-fp-ing-queuing at LAG level:

- To enable per-fp-ing-queuing, the LAG must be in access mode
- The LAG mode cannot be set to network mode when the feature is enabled
- Per-fp-ing-queuing can only be set if no port members exists in the LAG

Per-fp-egr-queuing

Per-fp-egr-queuing optimization for LAG ports provides the ability to reduce the number of egress resources consumed by each SAP on a LAG, and by any encap groups that exist on those SAPs.

When the feature is enabled in the **config>lag>access** context, the queue and virtual scheduler allocation will be optimized. Only one queuing set and one H-QoS virtual scheduler tree per SAP/encap group will be allocated per egress forwarding path (FP) instead of one set per each port of the LAG. In case of a link failure/recovery, egress traffic uses failover queues while the queues are moved over to a newly active link.

Per-fp-egr-queuing can be enabled on existing LAG with services as long as the following conditions are met.

- The LAG's mode must be **access** or **hybrid**.
- The LAG's port-type must be **standard**.
- The LAG must have either **per-link-hash** enabled or all SAPs on the LAG must use **per-service-hashing** only and be of a type: VPLS SAP, i-VPLS SAP, or e-Pipe VLL or PBB SAP.
- The system must be, at minimum, in chassis mode **d** (**configure>system>chassis-mode**)

To disable per-fp-egr-queuing, all ports must first be removed from a given LAG.

Per-fp-sap-instance

Per-fp-sap-instance optimization for LAG ports provides the ability to reduce the number of SAP instance resources consumed by each SAP on a lag.

When the feature is enabled, in the config>lag>access context, a single SAP instance is allocated on ingress and on egress per each forwarding path instead of one per port. Thanks to an optimized resource allocation, the SAP scale on a line card will increase, if a LAG has more than one port on that line card. Because SAP instances are only allocated per forwarding path complex, h/w reprogramming must take place when as result of LAG links going down or up, a SAP is moved from one LAG port on a given line card to another port on a given line card within the same forwarding complex. This results in an increased data outage when compared to per-fp-sap-instance feature being disabled. During the reprogramming, failover queues are used when SAP queues are reprogrammed to a new port. Any traffic using failover queues will not be accounted for in SAPs statistics and will be processed at best-effort priority.

The following rules apply when configuring per-fp-sap-instance on a given LAG:

- Minimum chassis mode D is required.
- Per-fp-sap-ingress-queing and per-fp-sap-egr-queing must be enabled.
- The functionality can be enabled/disabled on LAG with no member ports only. Services can be configured.

Other caveats:

- SAP instance optimization applies to LAG-level. Whether a LAG is sub-divided into sub-groups or not, the resources are allocated per forwarding path for all complexes LAG's links are configured on (i.e. irrespective of whether a given sub-group a SAP is configured on uses that complex or not).
- Egress statistics continue to be returned per port when SAP instance optimization is enabled. If a LAG links are on a single forwarding complex, all ports but one will have no change in statistics for the last interval – unless a SAP moved between ports during the interval.
- Rollback that changes per-fp-sap-instance configuration is service impacting.

LAG and ECMP Hashing

When a requirement exists to increase the available bandwidth for a logical link that exceeds the physical bandwidth or add redundancy for a physical link, typically one of two methods is applied: equal cost multi-path (ECMP) or Link Aggregation (LAG). A system can deploy both at the same time using ECMP of two or more Link Aggregation Groups (LAG) and/or single links.

Different types of hashing algorithms can be employed to achieve one of the following objectives:

- ECMP and LAG load balancing should be influenced solely by the offered flow packet. This is referred to as *per-flow* hashing.
- ECMP and LAG load balancing should maintain consistent forwarding within a given service. This is achieved using *consistent per-service* hashing.
- LAG load balancing should maintain consistent forwarding on egress over a single LAG port for a specific network interface, SAP, etc. This is referred to as *per link* hashing (including explicit per link hashing with LAG link map profiles). Note that if multiple ECMP paths use a LAG with per link hashing, the ECMP load balancing is done using either *per flow* or *consistent per service* hashing.

These hashing methods are described in the following subsections. Although multiple hashing options may be configured for a given flow at the same time, only one method will be selected to hash the traffic based on the following decreasing priority order:

For ECMP load balancing:

1. Consistent per service hashing
2. Per flow hashing

For LAG load balancing:

1. LAG link map profile
2. Per link hash
3. Consistent per service hashing
4. Per flow hashing

Per Flow Hashing

Per flow hashing uses information in a packet as an input to the hash function ensuring that any given flow maps to the same egress LAG port/ECMP path. Note that because the hash uses information in the packet, traffic for the same SAP/interface may be sprayed across different ports of a LAG or different ECMP paths. If this is not desired, other hashing methods outlined in this section can be used to change that behavior. Depending on the type of traffic that needs to be distributed into an ECMP and/or LAG, different variables are used as input to the hashing

algorithm that determines the next hop selection. The following outlines default per flow hashing behavior for those different types of traffic:

- VPLS known unicast traffic is hashed based on the IP source and destination addresses for IP traffic, or the MAC source and destination addresses for non-IP traffic. The MAC SA/DA are hashed and then, if the Ethertype is IPv4 or IPv6, the hash is replaced with one based on the IP source address/destination address.
- VPLS multicast, broadcast and unknown unicast traffic.
 - Traffic transmitted on SAPs is not sprayed on a per-frame basis, but instead the service ID is used to pick ECMP and LAG paths statically.
 - Traffic transmitted on SDPs is hashed on a per packet basis in the same way as VPLS unicast traffic. However, per packet hashing is applicable only to the distribution of traffic over LAG ports, as the ECMP path is still chosen statically based on the service ID.

Data is hashed twice to get the ECMP path. If LAG and ECMP are performed on the same frame, the data will be hashed again to get the LAG port (three hashes for LAG). However, if only LAG is performed, then hashing will only be performed twice to get the LAG port.
 - Multicast traffic transmitted on SAPs with IGMP snooping enabled is load-balanced based on the internal multicast ID, which is unique for every (s,g) record. This way, multicast traffic pertaining to different streams is distributed across different LAG member ports.
 - The hashing procedure that used to be applied for all VPLS BUM traffic would result in PBB BUM traffic being sent out on BVPLS SAP to follow only a single link when MMRP was not used. Therefore, in chassis mode D, traffic flooded out on egress BVPLS SAPs is now load spread using the algorithm described above for VPLS known unicast.
- Unicast IP traffic routed by a router is hashed using the IP SA/DA in the packet.
- MPLS packet hashing at an LSR is based on the whole label stack, along with the incoming port and system IP address. Note that the EXP/TTL information in each label is not included in the hash algorithm. This method is referred to as *Label-Only Hash* option and is enabled by default, or can be re-instated in CLI by entering the *lbl-only* keyword. A couple of options to further hash on the header of an IP packet in the payload of the MPLS packet are also provided.
- VLL traffic from a service access point is not sprayed on a per-packet basis, but as for VPLS flooded traffic, the service ID is used to pick one of the ECMP/LAG paths. The exception to this is when shared-queuing is configured on an e-pipe SAP, i-pipe SAP, or f-pipe SAP, or when H-POL is configured on an e-pipe SAP. In those cases, traffic spraying is the same as for VPLS known unicast traffic. Packets of the above VLL services received on a spoke-SDP are sprayed the same as for VPLS known unicast traffic.
- Note that a-pipe and c-pipe VLL packets are always sprayed based on the service-id in both directions.

- Multicast IP traffic is hashed based on an internal multicast ID, which is unique for every record similar to VPLS multicast traffic with IGMP snooping enabled.

In addition to the above outlined per-flow hashing inputs SROS supports multiple option to modify default hash inputs.

For all cases that involve per-packet hashing, the NPA produces a 20-bit result based on hashing the relevant packet data. This result is input to a modulo like calculation (divide by the number of routes in the ECMP and use the remainder) to determine the ECMP index.

If the ECMP index results in the selection of a LAG as the next hop, then the hash result is hashed again and the result of the second hash is input to the modulo like operation (divide by the number of ports in the LAG and use the remainder) to determine the LAG port selection.

Note however that when the ECMP set includes an IP interface configured on a spoke-SDP (IES/VPRN spoke interface), or a Routed VPLS interface, the unicast IP packets—which will be sprayed over this interface—will not be further sprayed over multiple RSVP LSPs (part of the same SDP), or multiple LDP FEC next-hops when available. In this case, a single RSVP LSP or LDP FEC next-hop will be selected based on a modulo operation of the service ID. The second round of the hash is exclusively used for LAG link selection. IP unicast packets from different IES/VPRN services or Routed VPLS services will be distributed across RSVP LSPs or LDP FEC next-hops based on the modulo operation of their respective service ID.

Changing Default Per Flow Hashing Inputs

For some traffic patterns or specific deployments, per-flow hashing is desired but the hashing result using default hash inputs as outlined above may not be produce a desired distribution. To alleviate this issue, SROS allows operators to modify default hash inputs as outlined in the following subsections.

LSR Hashing

The LSR hash routine operates on the label stack only. However, there is also the ability to hash on the IP header if a packet is IP. An LSR will consider a packet to be IP if the first nibble following the bottom of the label stack is either 4 (IPv4) or 6 (IPv6). This allows the user to include an IP header in the hashing routine at an LSR for the purpose of spraying labeled IP packets over multiple equal cost paths in ECMP in an LDP LSP and/or over multiple links of a LAG group in all types of LSPs.

The user enables the LSR hashing on label stack and/or IP header by entering the following system-wide command: **config>system>lsr-load-balancing [lbl-only | lbl-ip | ip-only]**

By default, the 7x50 LSR falls back to the hashing on label stack only. This option is referred to as lbl-only and the user can revert to this behavior by entering one of the two commands:

```
config>system>lsr-load-balancing lbl-only
```

```
config>system>no lsr-load-balancing
```

The user can also selectively enable or disable the inclusion of label stack and IP header in the LSR hash routine on a specific network interface by entering the following command:

```
config>router>interface>lsr-load-balancing [lbl-only | lbl-ip | ip-only]
```

This provides some control to the user such that this feature is disabled if labeled packets received on a specific interface include non IP packets that can be confused by the hash routine for IP packets. These could be VLL and VPLS packets without a PW control word.

When the user performs the **no** form of this command on an interface, the interface inherits the system level configuration.

The default **lbl-only** hash option and the label-ip option with IPv4 payload is supported on all platforms and chassis modes. The **ip-only** option with both IPv4 and IPv6 payloads as well as the lbl-ip option with IPv6 payload are only supported on IP interfaces on IOM3/IMM ports.

LSR Default Hash Routine—Label-Only Hash Option

The following is the behavior of ECMP and LAG hashing at an LSR in the existing implementation. These are performed in two rounds.

First the ECMP hash. It consists of an initial hash based on the source port/system IP address. Each label in the stack is then hashed separately with the result of the previous hash, up to a maximum of five labels. The net result will be used to select which LDP FEC next-hop to send the packet to using a modulo operation of the net result with the number of next-hops. If there is a single next-hop for the LDP FEC, or if the packet is received on an RSVP LSP ILM, then a single next-hop exists.

This same net result will feed to a second round of hashing if there is LAG on the egress port where the selected LDP or RSVP LSP has its NHLFE programmed.

LSR Label-IP Hash Option Enabled

In the first hash round for ECMP, the algorithm will parse down the label stack and once it hits the bottom it checks the next nibble. If the nibble value is 4 then it will assume it is an IPv4 packet. If the nibble value is 6 then it will assume it is an IPv6 packet. In both cases, the result of the label hash is fed into another hash along with source and destination address fields in the IP packet header. Otherwise, it will just use the label stack hash already calculated for the ECMP path selection.

If there are more than five labels in the stack, then the algorithm will also use the result of the label hash for the ECMP path selection.

The second round of hashing for LAG re-uses the net result of the first round of hashing. This means IPv6 packets will continue to be hashed on label stack only.

LSR IP-Only Hash Option Enabled

This option behaves like the label-IP hash option except that when the algorithm reached the bottom of the label stack in the ECMP round and finds an IP packet, it throws the outcome of the label hash and only uses the source and destination address fields in the IP packet's header.

LSR Ethernet Encapsulated IP Hash only Option Enabled

This option behaves like LSR IP only hash except for how the IP SA/DA information is found. The following conditions are verified to find IP SA/DA for hash.

- Label stack must not exceed 3 labels deep
- After the bottom of the stack is reached, the hash algorithm verifies that what follows is Ethernet II untagged frame (by looking at the value of ethertype at the expected packet location whether it contains Ethernet encapsulated IPv4 (0x0800) or IPv6 (0x086D) value.

When the ethertype verification passes, the first nibble of the expected IP packet location is then verified to be 4 (IPv4) or 6 (IPv6).

L4 Load Balancing

Operator may enable L4 load balancing to include TCP/UDP source/destination port numbers in addition to source/destination IP addresses in per flow hashing of IP packets. By including the L4 information, a SA/DA default hash flow can be sub-divided into multiple finer-granularity flows if the ports used between a given SA/DA vary.

L4 load balancing can be enabled/disabled on system and interface levels. When enabled, the extra L4 port inputs apply to per-flow hashing for unicast IP traffic and multicast traffic (if **mc-enh-load-balancing** is enabled)

System IP Load Balancing

This enhancement adds an option to add the system IP address into the hash algorithm. This adds a per system variable so that traffic being forward through multiple routers with similar ECMP paths will have a lower chance of always using the same path to a given destination.

Currently, if multiple routers have the same set of ECMP next hops, traffic will use the same nexthop at every router hop. This can contribute to the unbalanced utilization of links. The new hash option avoids this issue.

This feature when enabled, enhances the default per-flow hashing algorithm described earlier. It however does not apply to services which packets are hashed based on service-id or when per service consistent hashing is enabled. This hash algorithm is only supported on IOM3-XP/IMMs or later generations of hardware. The System IP load balancing can be enabled per-system only.

TEID Hash for GTP-Encapsulated Traffic

This options enables TEID hashing on L3 interfaces. The hash algorithm identifies GTP-C or GTP-U by looking at the UDP destination port (2123 or 2152) of an IP packet to be hashed. If the value of the port matches, the packet is assumed to be GTP-U/C. For GTPv1 packets TEID value from the expected header location is then included in hash. For GTPv2 packets the TEID flag value in the expected header is additionally checked to verify whether TEID is present. If TEID is present, it is included in hash algorithm inputs. TEID is used in addition to GTP tunnel IP hash inputs: SA/DA and SPort/DPort (if L4 load balancing is enabled). If a non-GTP packet is received on the GTP UDP ports above, the packets will be hashed as GTP.

Enhanced Multicast Load Balancing

Enhanced multicast load balancing allows operators to replace the default multicast per flow hash input (internal multicast ID) with information from the packet. When enabled, multicast traffic for Layer 3 services (such as IES, VPRN, r-VPLS) and ng-MVPN (multicast inside RSVP-TE, LDP LSPs) are hashed using information from the packet. Which inputs are chosen depends on which per flow hash inputs options are enabled based on the following:

- IP replication—The hash algorithm for multicast mimics unicast hash algorithm using SA/DA by default and optionally TCP/UDP ports (L4 load balancing enabled) and/or system IP (System IP load balancing enabled).
- MPLS replication—The hash algorithm for multicast mimics unicast hash algorithm described in [LSR Hashing on page 52](#).



NOTE: Enhanced multicast load balancing requires minimum chassis mode D. It is not supported with L2 and ESM services. It is supported on 7950 platforms.

Per Link Hashing

The hashing feature described in this section applies to traffic going over LAG and MC-LAG. Per link hashing ensures all data traffic on a given SAP or network interface uses a single LAG port on egress. Because all traffic for a given SAP/network interface egresses over a single port, QoS SLA enforcement for that SAP, network interface is no longer impacted by the property of LAG (distributing traffic over multiple links). Internally-generated, unique IDs are used to distribute SAPs/network interface over all active LAG ports. As ports go UP and DOWN, each SAP and network interface is automatically rehashed so all active LAG ports are always used.

The feature is best suited for deployments when SAPs/network interfaces on a given LAG have statistically similar BW requirements (since per SAP/network interface hash is used). If more control is required over which LAG ports SAPs/network interfaces egress on, a LAG link map profile feature described later in this guide may be used.

Per link hashing, can be enabled on a LAG as long as the following conditions are met:

- LAG **port-type** must be *standard*.
- LAG **access adapt-qos** must be *link* (for LAGs in **mode** access or hybrid).
- System must be at minimum in chassis mode *d* (**configure system chassis-mode**)
- LAG mode is access/hybrid and the **access adapt-qos** mode is distribute **include-egr-hash-cfg**

Explicit Per Link Hash Using LAG Link Mapping Profiles

The hashing feature described in this section applies to traffic going over LAG and MC-LAG. LAG link mapping profile feature gives operators full control of which links SAPs/network interface use on a LAG egress and how the traffic is rehashed on a LAG link failure. Some benefits that such functionality provides include:

- Ability to perform management level admission control onto LAG ports thus increasing overall LAG BW utilization and controlling LAG behavior on a port failure.
- Ability to strictly enforce QoS contract on egress for a SAP/network interface or a group of SAPs/network interfaces by forcing it/them to egress over a single port and using **access adapt-qos** link mode.

To enable LAG Link Mapping Profile Feature on a given LAG, operators configure one or more of the available LAG link mapping profiles on the LAG and then assign that profile(s) to all or a subset of SAPs and network interfaces as needed. Enabling per LAG link Mapping Profile is allowed on a LAG with services configured, a small outage may take place as result of re-hashing SAP/network interface when a lag profile is assigned to it.

Each LAG link mapping profile allows operators to configure:

- Primary link—defines a port of the LAG to be used by a SAP/network interface when the port is UP. Note that a port cannot be removed from a LAG if it is part of any LAG link profile.
- Secondary link—defines a port of the LAG to be used by a SAP/network interface as a backup when the primary link is not available (not configured or down) and the secondary link is UP.
- Mode of operation when neither primary, nor secondary links are available (not configured or down):
 - **discard** – traffic for a given SAP/network interface will be dropped to protect other SAPs/network interfaces from being impacted by re-hashing these SAPs/network interfaces over remaining active LAG ports.

Note: SAP/network interface status will not be affected when primary and secondary links are unavailable, unless an OAM mechanism that follows the data path hashing on egress is used and will cause a SAP/network interface to go down

- **per-link-hash** – traffic for a given SAP/network interface will be re-hashed over remaining active ports of a LAG links using per-link-hashing algorithm. This behavior ensures SAP/network interfaces using this profile will be given available resources of other active LAG ports even if that means impacting other SAP/network interfaces on the LAG. The system will use the QoS configuration to provide fairness and priority if congestion is caused by the default-hash recovery.

LAG link mapping profiles, can be enabled on a LAG as long as the following conditions are met:

- LAG **port-type** must be *standard*.
- LAG **access adapt-qos** must be *link* (for LAGs in **mode** access or hybrid)
- All ports of a LAG on a given router must belong to a single sub-group.
- System must be at minimum in chassis mode *d* (**configure system chassis-mode**)
- Access adapt-qos mode is distribute include-egr-hash-cfg.

LAG link mapping profile can co-exist with any-other hashing used over a given LAG (for example, per flow hashing or per-link-hashing). SAPs/network interfaces that have no link mapping profile configured will be subject to LAG hashing, while SAPs/network interfaces that have configured LAG profile assigned will be subject to LAG link mapping behavior, which is described above.

Consistent Per Service Hashing

The hashing feature described in this section applies to traffic going over LAG, Ethernet tunnels (eth-tunnel) in loadsharing mode, or CCAG load balancing for VSM redundancy. The feature does not apply to ECMP.

Per-service-hashing was introduced to ensure consistent forwarding of packets belonging to one service. The feature can be enabled using the **[no] per-service-hashing** configuration option under **config>service>epipe** and **config>service>vpls**, valid for Epipe, VPLS, PBB Epipe, IVPLS and BVPLS.

The following behavior applies to the usage of the [no] per-service-hashing option.

- The setting of the PBB Epipe/I-VPLS children dictates the hashing behavior of the traffic destined to or sourced from an Epipe/I-VPLS endpoint (PW/SAP).
- The setting of the B-VPLS parent dictates the hashing behavior only for transit traffic through the B-VPLS instance (not destined to or sourced from a local I-VPLS/Epipe children).

The following algorithm describes the hash-key used for hashing when the new option is enabled:

- If the packet is PBB encapsulated (contains an I-TAG ethertype) at the ingress side, use the ISID value from the I-TAG
- If the packet is not PBB encapsulated at the ingress side
 - For regular (non-PBB) VPLS and EPIPE services, use the related service ID
 - If the packet is originated from an ingress IVPLS or PBB Epipe SAP
 - If there is an ISID configured use the related ISID value
 - If there is no ISID yet configured use the related service ID

- For BVPLS transit traffic use the related flood list id
 - Transit traffic is the traffic going between BVPLS endpoints
 - An example of non-PBB transit traffic in BVPLS is the OAM traffic
- The above rules apply regardless of traffic type
 - Unicast, BUM flooded without MMRP or with MMRP, IGMP snooped

Operators may sometimes require the capability to query the system for the link in a LAG or Ethernet tunnel that is currently assigned to a given service-id or ISID. This ability is provided using the **tools>dump>map-to-phy-port** {**ccag** *ccag-id* | **lag** *lag-id* | **eth-tunnel** *tunnel-index*} {**isid** *isid* [**end-isid** *isid*] | **service** *servid-id* | *svc-name* [**end-service** *service-id* | *syc-name*]} [**summary**] command.

A sample usage is as follows:

```
A:Dut-B# tools dump map-to-phy-port lag 11 service 1
```

ServiceId	ServiceName	ServiceType	Hashing	Physical Link
1		i-vpls	per-service(if enabled)	3/2/8

```
A:Dut-B# tools dump map-to-phy-port lag 11 isid 1
```

ISID	Hashing	Physical Link
1	per-service(if enabled)	3/2/8

```
A:Dut-B# tools dump map-to-phy-port lag 11 isid 1 end-isid 4
```

ISID	Hashing	Physical Link
1	per-service(if enabled)	3/2/8
2	per-service(if enabled)	3/2/7
3	per-service(if enabled)	1/2/2
4	per-service(if enabled)	1/2/3

ESM – LAG Hashing per Vport

Background

Vport is a 7x50 BNG representation of a remote traffic aggregation point in the access network. It is a level in the hierarchical QoS model implemented within the 7x50 BNG that requires QoS treatment.

When 7x50 BNG is connected to access network via LAG, a VPort construct within the BNG is instantiated per member link on that LAG. Each instance of the Vport in such a configuration receives the entire amount of configured bandwidth. When traffic is sprayed in a per-subscriber fashion over member links in an LAG without awareness of the Vport, it can lead to packet drops on one member link irrespective of the relative traffic priority on another LAG member link in the same Vport. The reason is that multiple Vport instances of the same Vport on different LAG member links are not aware of each other.

With a small number of subscribers per Vport and a great variation in bandwidth service offering per subscriber (from mbps to gbps), there is a great chance that the load distribution between the member links will be heavily unbalanced. For example, if the lag consists of two member links on the same IOM, three 1Gbps high priority subscribers can saturate the 2Gbps Vport bandwidth on one member link of the LAG. And all the while, twenty low priority 10Mbps subscribers that are using the other link are significantly under-utilizing available bandwidth on the corresponding Vport.

To remedy this situation, all traffic flowing through the same Vport must be hashed to a single LAG member link. This way, the traffic treatment will be controlled by a single Vport instance, and achieve a desired behavior where low priority 10Mbps subscribers traffic will be affected before any traffic from the high priority subscribers.

Hashing per Vport

Hashing traffic per Vport ensures that the traffic on the same PON (or DSLAM) traverse the same Vport, and therefore, it is the same member link that this Vport is associated with. The Vport instances of the same Vport on another member links are irrelevant for QoS treatment.

The Vport in 7x50 is referenced via inter-dest-string, which can be returned via Radius. For this reason, the terms hashing per inter-dest-string or hashing per vport can be interchangeably used.

If the subscriber is associated with a Vport, hashing will be automatically performed per inter-dest-string. In case that no such association exists, hashing will default to per-subscriber hashing.

In certain cases, S-vlan tag can represent Vport. In such a case, per S-vlan hashing is desired. This can be implicitly achieved by the following configuration:

```

configure
  subscr-mgmt
    msap-policy <name>
    sub-sla-mgmt
    def-inter-dest-id use-top-queue

configure
  port <port-id>
  ethernet
  access
  egress
  vport <name>
  host-match dest <s-tag>

```

Through this CLI hierarchy, S-tag is implicitly associated with the inter-dest-string and consequently with the Vport.

Link Placement

This feature requires that all active member ports in a LAG reside on the same forwarding complex (IOM/IMM).

Multicast Consideration

Multicast traffic that is directly replicated per subscriber follows the same hashing algorithm as the rests of the subscribers (per inter-dest-string hashing).

Multicast traffic that is redirected to a regular L3 interface outside of the ESM will be hashed per destination group (or IP address).

VPLS and Capture SAP Considerations

VPLS environment in conjunction with ESM allows hashing based on destination mac address. This is achieved through the following CLI hierarchy:

```

configure
  service vpls <vpls-id>
  sap lag-<id>
  sub-sla-mgmt
  mac-da-hashing

```

Note: This is only applicable to L2 ESM. In the case where this is configured AND vport hashing is desired, the following order of evaluation will be executed:

1. Hashing based on subscriber-id or inter-dest-string
2. If configured, mac-da-hashing

Hashing per inter-dest-string will win if <Vport, subscriber> association is available at the same time as the mac-da-hashing is configured.

Mac-da-hashing mechanism cannot transition from capture SAP to a derived MSAP.

LSR Default Hash Routine— Label-Only Hash Option

The following is the behavior of ECMP and LAG hashing at an LSR in the existing implementation. These are performed in two rounds.

First the ECMP hash. It consists of an initial hash based on the source port/system IP address. Each label in the stack is then hashed separately with the result of the previous hash, up to a maximum of five labels. The net result will be used to select which LDP FEC next-hop to send the packet to using a modulo operation of the net result with the number of next-hops. If there is a single next-hop for the LDP FEC, or if the packet is received on an RSVP LSP ILM, then a single next-hop exists.

This same net result will feed to a second round of hashing if there is LAG on the egress port where the selected LDP or RSVP LSP has its NHLFE programmed.

LSR Label-IP Hash Option Enabled

In the first hash round for ECMP, the algorithm will parse down the label stack and once it hits the bottom it checks the next nibble. If the nibble value is 4 then it will assume it is an IPv4 packet. If the nibble value is 6 then it will assume it is an IPv6 packet. In both cases, the result of the label hash is fed into another hash along with source and destination address fields in the IP packet's header. Otherwise, it will just use the label stack hash already calculated for the ECMP path selection.

If there are more than five labels in the stack, then the algorithm will also use the result of the label hash for the ECMP path selection.

The second round of hashing for LAG re-uses the net result of the first round of hashing. This means IPv6 packets will continue to be hashed on label stack only.

LSR IP-Only Hash Option Enabled

This option behaves like the label-IP hash option except that when the algorithm reached the bottom of the label stack in the ECMP round and finds an IP packet, it throws the outcome of the label hash and only uses the source and destination address fields in the IP packet's header.

LAG Hold Down Timers

Operators can configure multiple hold down timers that allow control how quickly LAG responds to operational port state changes. The following timers are supported:

1. Port-level hold-time up/down timer
This optional timer allows operator to control delay for adding/removing a port from LAG when the port comes UP/goes DOWN. Each LAG port runs the same value of the timer, configured on the primary LAG link. See Port Link Dampening description in Port Features section of this guide for more details on this timer.
2. Sub-group-level hold-time timer
This optional timer allows operator to control delay for a switch to a new candidate sub-group selected by LAG sub-group selection algorithm from the current, operationally UP sub-group. The timer can also be configured to never expire, which prevents a switch from operationally up sub-group to a new candidate sub-group (manual switchover is possible using tools perform force lag command). Note that, if the port link dampening is deployed, the port level timer must expire before the sub-group-selection takes place and this timer is started. Sub-group-level hold-down timer is supported with LAGs running LACP only.
3. LAG-level hold-time down timer
This optional timer allows operator to control delay for declaring a LAG operationally down when the available links fall below the required port/BW minimum. The timer is recommended for LAG connecting to MC-LAG systems. The timer prevents a LAG going down when MC-LAG switchover executes break-before-make switch. Note that, if the port link dampening is deployed, the port level timer must expire before the LAG operational status is processed and this timer is started.

BFD over LAG Links

The router supports the application of BFD to monitor individual LAG link members to speed up the detection of link failures. When BFD is associated with an Ethernet LAG, BFD sessions are setup over each link member, and are referred to as micro-BFD sessions. A link is not operational in the associated LAG until the associated micro-BFD session is fully established. In addition, the link member is removed from the operational state in the LAG if the BFD session fails.

When configuring the local and remote IP address for the BFD over LAG link sessions, the *local-ip* parameter should always match an IP address associated with the IP interface to which this LAG is bound. In addition, the *remote-ip* parameter should match an IP address on the remote system and should also be in the same subnet as the *local-ip* address. If the LAG bundle is re-associated with a different IP interface, the *local-ip* and *remote-ip* parameters should be modified to match the new IP subnet.

-

Point-to-Point (p2p) Redundant Connection Across Layer 2/3 VPN Network

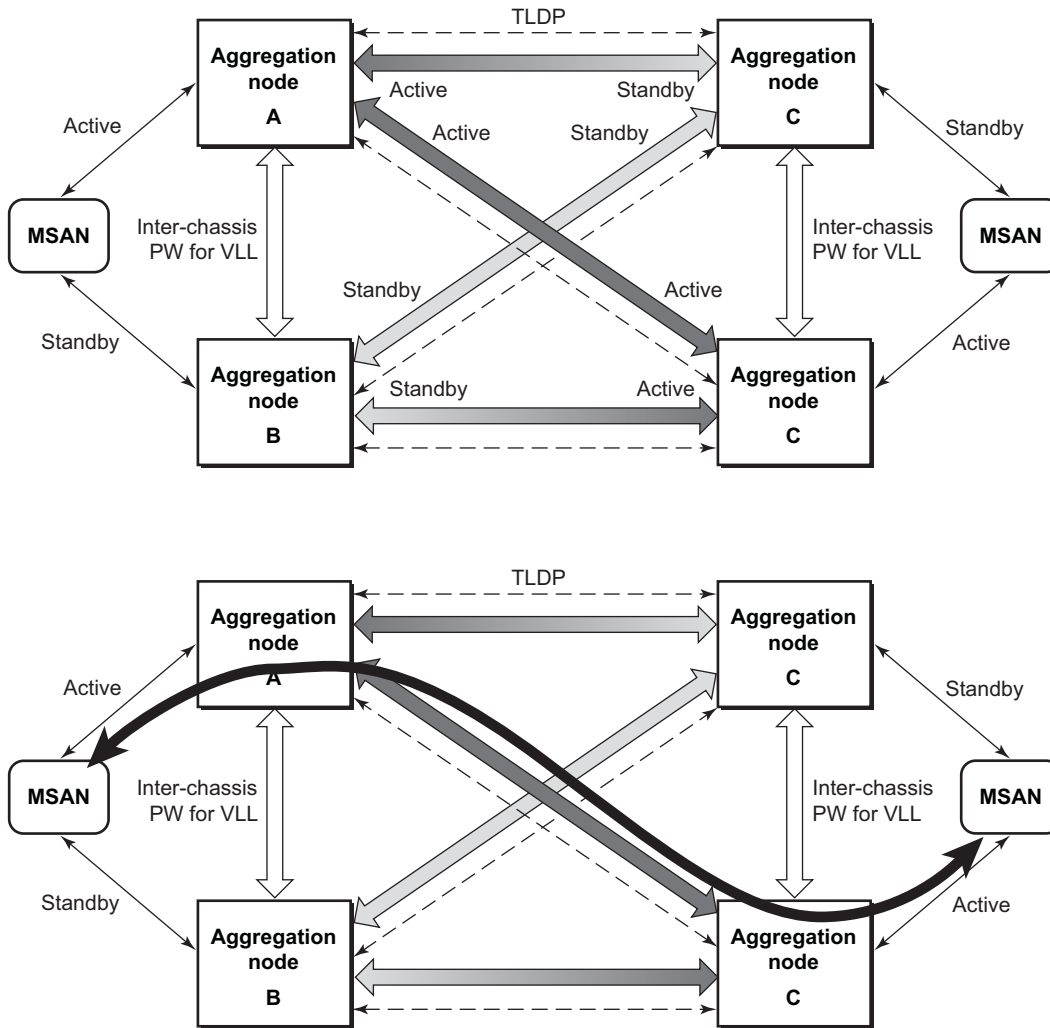

OSSG116

Figure 9: P2P Redundant Connection Through a Layer 2 VPN Network

Figure 9 shows the connection between two multi-service access nodes (MSANs) across network based on Layer 2/3 VPN pseudo-wires. The connection between MSAN and a pair of PE routers is realized by MC-LAG. From MSAN perspective, redundant pair of PE routers acts as a single partner in LACP negotiation. At any point in time, only one of the routers has an active link(s) in a given LAG. The status of LAG links is reflected in status signaling of pseudo-wires set between

all participating PEs. The combination of active and stand-by states across LAG links as well and pseudo-wires give only 1 unique path between pair of MSANs.

Note that the configuration in [Figure 9](#) depicts one particular configuration of VLL connections based on MC-LAG, particularly the VLL connection where two ends (SAPs) are on two different redundant-pairs. In addition to this, other configurations are possible, such as:

- Both ends of the same VLL connections are local to the same redundant-pair.
- One end VLL endpoint is on a redundant-pair the other on single (local or remote) node.

G.8032 Protected Ethernet Rings

Ethernet ring protection switching offers ITU-T G.8032 specification compliance to achieve resiliency for Ethernet Layer 2 networks. Similar to G.8031 linear protection (also called Automatic Protection Switching (APS)), G.8032 (Eth-ring) is also built on Ethernet OAM and often referred to as Ring Automatic Protection Switching (R-APS).

For further information regarding Ethernet rings, see G.8032 Protected Ethernet Rings section in the Services Guide.

802.3ah OAM

802.3ah Clause 57 (**efm-oam**) defines the Operations, Administration, and Maintenance (OAM) sub-layer, which provides mechanisms useful for monitoring link operation such as remote fault indication and remote loopback control. In general, OAM provides network operators the ability to monitor the health of the network and quickly determine the location of failing links or fault conditions. **efm-oam** described in this clause provides data link layer mechanisms that complement applications that may reside in higher layers.

OAM information is conveyed in slow protocol frames called OAM protocol data units (OAMPDUs). OAMPDUs contain the appropriate control and status information used to monitor, test and troubleshoot OAM-enabled links. OAMPDUs traverse a single link, being passed between peer OAM entities, and as such, are not forwarded by MAC clients (like bridges or switches).

The following **efm-oam** functions are supported:

- **efm-oam** capability discovery.
- Active and passive modes.
- Remote failure indication — Handling of critical link events (link fault, dying gasp, etc.)
- Loopback — A mechanism is provided to support a data link layer frame-level loopback mode. Both remote and local loopback modes are supported.
- **efm-oam** PDU tunneling.
- High resolution timer for **efm-oam** in 100ms interval (minimum).

When the **efm-oam** protocol fails to negotiate a peer session or encounters a protocol failure following an established session the *Port State* will enter the *Link Up* condition. This port state is used by many protocols to indicate the port is administratively UP and there is physical connectivity but a protocol, such as **efm-oam**, has caused the ports operational state to enter a DOWN state. A reason code has been added to help discern if the **efm-oam** protocol is the underlying reason for the Link Up condition.

```
show port
=====
Ports on Slot 1
=====
Port      Admin Link Port   Cfg  Oper LAG/  Port Port Port   C/QS/S/XFP/
Id        State      State  MTU  MTU  Bndl Mode Encp Type  MDIMDX
-----
1/1/1     Down   No   Down   1578 1578  - netw null xcme
1/1/2     Down   No   Down   1578 1578  - netw null xcme
1/1/3     Up     Yes  Link Up 1522 1522  - accs qinq xcme
1/1/4     Down   No   Down   1578 1578  - netw null xcme
1/1/5     Down   No   Down   1578 1578  - netw null xcme
1/1/6     Down   No   Down   1578 1578  - netw null xcme

# show port 1/1/3
=====
Ethernet Interface
```

```

=====
Description      : 10/100/Gig Ethernet SFP
Interface        : 1/1/3
Link-level       : Ethernet
Admin State      : up
Oper State       : down
Reason Down      : efmOamDown
Physical Link    : Yes
Single Fiber Mode : No
IfIndex          : 35749888
Last State Change : 12/18/2012 15:58:29
Last Cleared Time : N/A
Phys State Chng Cnt: 1

Oper Speed       : N/A
Config Speed    : 1 Gbps
Oper Duplex     : N/A
Config Duplex   : full

MTU              : 1522
Min Frame Length : 64 Bytes
Hold time up    : 0 seconds
Hold time down  : 0 seconds
DDM Events      : Enabled

Configured Mode  : access
Dot1Q Ethertype : 0x8100
PBB Ethertype   : 0x88e7
Ing. Pool % Rate : 100
Ing. Pool Policy : n/a
Egr. Pool Policy : n/a
Net. Egr. Queue Pol: default
Egr. Sched. Pol : n/a
Auto-negotiate  : true
Oper Phy-tx-clock : not-applicable
Accounting Policy : None
Acct Plcy Eth Phys : None
Egress Rate     : Default
Load-balance-algo : Default

Encap Type      : QinQ
QinQ Ethertype  : 0x8100
Egr. Pool % Rate : 100

MDI/MDX         : unknown
Collect-stats   : Disabled
Collect Eth Phys : Disabled
Ingress Rate    : Default
LACP Tunnel     : Disabled

Down-when-looped : Disabled
Loop Detected    : False
Use Broadcast Addr : False

Keep-alive      : 10
Retry           : 120

Sync. Status Msg. : Disabled
Tx DUS/DNU       : Disabled
SSM Code Type    : sdh

Rx Quality Level : N/A
Tx Quality Level : N/A

Down On Int. Error : Disabled

CRC Mon SD Thresh : Disabled
CRC Mon SF Thresh : Disabled

CRC Mon Window   : 10 seconds

Configured Address : d8:ef:01:01:00:03
Hardware Address   : d8:ef:01:01:00:03

```

The operator also has the opportunity to decouple the **efm-oam** protocol from the port state and operational state. In cases where an operator wants to remove the protocol, monitor the protocol only, migrate, or make changes the **ignore-efm-state** can be configured under the `port>ethernet>efm-oam` hierarchy. When the **ignore-efm-state** command is configured on a port the protocol continues as normal. However, ANY failure in the protocol state machine (discovery, configuration, time-out, loops, etc...) will not impact the port on which the protocol is active and the optional ignore command is configured. There will only be a protocol warning message if there are issues with the protocol. The default behavior when this optional command is not configured means the port state will be affected by any **efm-oam** protocol fault or clear conditions. Adding and removing this optional ignore command will immediately represent the

Port State and *Oper State* based on the active configuration. For example, if the **ignore-efm-state** is configured on a port that is exhibiting a protocol error that protocol error does not affect the port state or operational state and there is no *Reason Down* code. If the **ignore-efm-state** is removed from a port with an existing **efm-oam** protocol error, the port will transition to *Link UP*, *Oper Down* with the reason code *efmOamDown*.

OAM Events

EFM OAM defines a set of events that may impact link operation. The following events are supported:

- Critical link events (defined in 802.3ah clause 57.2.10.1)
 - Link fault: the PHY has determined a fault has occurred in the receive direction of the local DTE.
 - Dying gasp: an unrecoverable local failure condition has occurred.
 - Critical event: an unspecified critical event has occurred.

These critical link events are signaled to the remote DTE by the flag field in OAM PDUs.

Remote Loopback

EFM OAM provides a link-layer frame loopback mode that can be remotely controlled.

To initiate remote loopback, the local EFM OAM client sends a loopback control OAM PDU by enabling the OAM remote-loopback command. After receiving the loopback control OAM PDU, the remote OAM client puts the remote port into local loopback mode.

To exit remote loopback, the local EFM OAM client sends a loopback control OAM PDU by disabling the OAM remote-loopback command. After receiving the loopback control OAM PDU, the remote OAM client puts the port back into normal forwarding mode.

Note that during remote loopback test operation, all frames except EFM OAM PDUs are dropped at the local port for the receive direction, where remote loopback is enabled. If local loopback is enabled, then all frames except EFM OAM PDUs are dropped at the local port for both the receive and transmit directions. This behavior may result in many protocols (such as STP or LAG) resetting their state machines.

Note that when a port is in loopback mode, service mirroring will not work if the port is a mirror-source or a mirror-destination.

802.3ah OAM PDU Tunneling for Epipe Service

The 7950 SR routers support 802.3ah. Customers who subscribe to Epipe service treat the Epipe as a wire, so they demand the ability to run 802.3ah between their devices which are located at each end of the Epipe.

Note: This feature only applies to port-based Epipe SAPs because 802.3ah runs at port level not VLAN level. Hence, such ports must be configured as null encapsulated SAPs.

When OAM PDU tunneling is enabled, 802.3ah OAM PDUs received at one end of an Epipe are forwarded through the Epipe. 802.3ah can run between devices that are located at each end of the Epipe. When OAM PDU tunneling is disabled (by default), OAM PDUs are dropped or processed locally according to the **efm-oam** configuration (**shutdown** or **no shutdown**).

Note that by enabling 802.3ah for a specific port and enabling OAM PDU tunneling for the same port are mutually exclusive. Enforcement is performed on the CLI level.

MTU Configuration Guidelines

Observe the following general rules when planning your service and physical MTU configurations:

- The 7950 SR must contend with MTU limitations at many service points. The physical (access and network) port, service, and SDP MTU values must be individually defined.
 - Identify the ports that will be designated as network ports intended to carry service traffic.
 - MTU values should not be modified frequently.
 - MTU values must conform to both of the following conditions:
 - The service MTU must be less than or equal to the SDP path MTU.
 - The service MTU must be less than or equal to the access port (SAP) MTU.
-

Default MTU Values

[Table 5](#) displays the default MTU values which are dependent upon the (sub-) port type, mode, and encapsulation.

Table 5: MTU Default Values

Port Type	Mode	Encap Type	Default (bytes)
Ethernet	access	null	1514
Ethernet	access	dot1q	1518
Other Ethernet	network	—	9212*

*The default MTU for Ethernet ports other than Fast Ethernet is actually the lesser of 9212 and any MTU limitations imposed by hardware which is typically 16K

Modifying MTU Defaults

MTU parameters should be modified on the service level as well as the port level.

- The service-level MTU parameters configure the service payload (Maximum Transmission Unit – MTU) in bytes for the service ID overriding the service-type default MTU.
- The port-level MTU parameters configure the maximum payload MTU size for an Ethernet port or SONET/SDH SONET path (sub-port), or a channel that is part of a LAG.

The default MTU values should be modified to ensure that packets are not dropped due to frame size limitations. The service MTU must be less than or equal to both the SAP port MTU and the SDP path MTU values. When an SDP is configured on a network port using default port MTU values, the operational path MTU can be less than the service MTU. In this case, enter the show service sdp command to check the operational state. If the operational state is down, then modify the MTU value accordingly.

Configuration Example

In order for the maximum length service frame to successfully travel from a local ingress SAP to a remote egress SAP, the MTU values configured on the local ingress SAP, the SDP (GRE or MPLS), and the egress SAP must be coordinated to accept the maximum frame size the service can forward. For example, the targeted MTU values to configure for a distributed Epipe service (ALA-A and ALA-B) are displayed in [Figure 10](#).

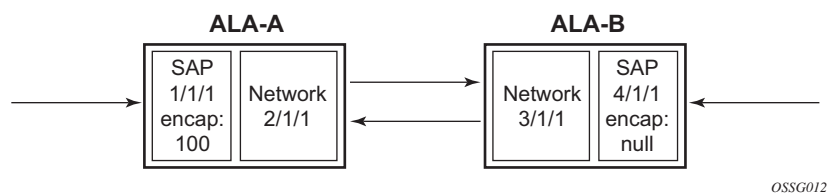

Figure 10: MTU Configuration Example

Table 6: MTU Configuration Example Values

	ALA-A		ALA-B	
	Access (SAP)	Network	Network	Access (SAP)
Port (slot/MDA/port)	1/1/1			
Mode type	dot1q	network	network	null
MTU	1518	1556	1556	1514

Since ALA-A uses Dot1q encapsulation, the SAP MTU must be set to 1518 to be able to accept a 1514 byte service frame (see [Table 5](#) for MTU default values). Each SDP MTU must be set to at least 1514 as well. If ALA-A's network port (2/1/1) is configured as an Ethernet port with a GRE SDP encapsulation type, then the MTU value of network ports 2/1/1 and 3/1/1 must *each* be at least 1556 bytes (1514 MTU + 28 GRE/Martini + 14 Ethernet). Finally, the MTU of ALA-B's SAP (access port 4/1/1) must be at least 1514, as it uses null encapsulation.

Deploying Preprovisioned Components

When a XCM/XMA is installed in a preprovisioned slot, the device detects discrepancies between the preprovisioned XCM/XMA type configurations and the types actually installed. Error messages display if there are inconsistencies and the card will not initialize.

When the proper preprovisioned XCM/XMA are installed into the appropriate chassis slot, alarm, status, and performance details will display.

Configuration Process Overview

Figure 11 displays the process to provision chassis slots, XCMs (cards), XMA (MDAs), and ports.

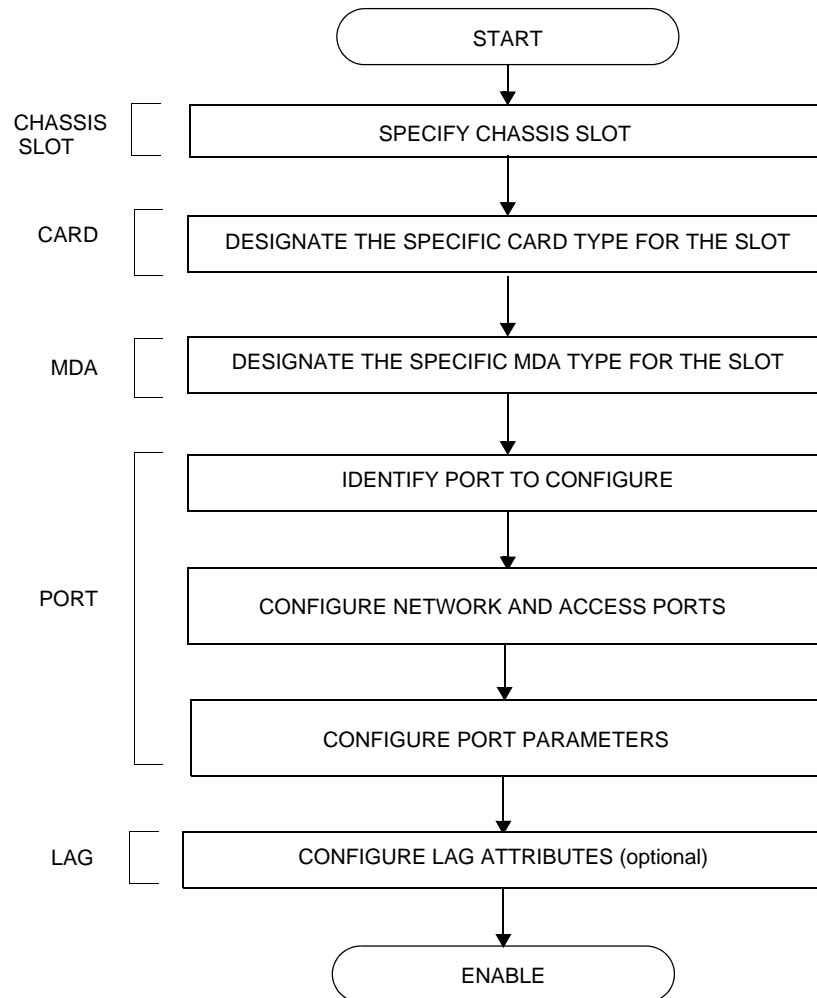

Figure 11: Slot, XCM (card), XMA (mda), and Port Configuration and Implementation Flow

Configuration Notes

The following information describes provisioning caveats:

- If a card or MDA (XMA) type is installed in a slot provisioned for a different type, the card will not initialize.
- A card and MDA (XMA) installed in an unprovisioned slot remain administratively and operationally down until the card type and MDA (XMA) is specified.
- Ports cannot be provisioned until the slot, card and MDA (XMA) type are specified.

Configuring Physical Ports with CLI

This section provides information to configure XCMs (cards), XMA (MDAs), and ports.

Topics in this section include:

- [Preprovisioning Guidelines on page 161](#)
 - [Predefining Entities on page 79](#)
 - [Preprovisioning a Port on page 81](#)
 - [Maximizing Bandwidth Use on page 82](#)
 - [Basic Configuration on page 83](#)
 - [Common Configuration Tasks on page 84](#)
 - [Configuring Ports on page 88](#)
 - [Configuring LAG Parameters on page 95](#)
 - [Common Configuration Tasks on page 84](#)
 - [Configuring XCMs \(Cards\) and XMA \(MDAs\) on page 85](#)
 - [Configuring Ports on page 88](#)
 - [Configuring Port Pool Parameters on page 88](#)
 - [Changing Hybrid-Buffer-Allocation on page 91](#)
 - [Configuring Ethernet Port Parameters on page 92](#)
 - [Configuring SONET/SDH Port Parameters on page 94](#)
 - [Configuring LAG Parameters on page 95](#)
 - [Configuring BFD on LAG Links on page 95](#)
 - [Service Management Tasks on page 97](#)
 - [Modifying or Deleting an XMA \(MDA\) on page 97](#)
 - [Modifying a Card Type on page 98](#)
 - [Deleting a Card on page 99](#)
 - [Deleting Port Parameters on page 99](#)
-

Predefining Entities

In order to initialize a card, the chassis slot, line card type, and XMA (MDA) type must match the preprovisioned parameters. In this context, *preprovisioning* means to configure the entity type (such as the line card type, MDA type, port, and interface) that is planned for a chassis slot, line card, or MDA. Preprovisioned entities can be installed but not enabled or the slots can be configured but remain empty until populated. *Provisioning* means that the preprovisioned entity is installed and enabled.

You can:

- Pre-provision ports and interfaces after the line card and XMA (MDA) types are specified.
- Install line cards in slots with no preconfiguration parameters specified. Once the card is installed, the card and XMA (MDA) types must be specified.
- Install a line card in a slot provisioned for a different card type (the card will not initialize). The existing card and XMA (MDA) configuration must be deleted and replaced with the current information.

Preprovisioning a Port

Before a port can be configured, the slot must be preprovisioned with an allowed card type and the XMA (MDA) must be preprovisioned with an allowed XMA (MDA) type.

Some recommendations to configure a port include:

- Ethernet
 - Configure an access port for customer facing traffic on which services are configured. An encapsulation type may be specified in order to distinguish services on the port or channel. Encapsulation types are not required for network ports.
 - To configure an Ethernet access port, refer to [on page 92](#).

Maximizing Bandwidth Use

Once ports are preprovisioned, Link Aggregation Groups (LAGs) can be configured to increase the bandwidth available between two nodes. All physical links or channels in a given LAG/bundle combine to form one logical connection. A LAG/bundle also provides redundancy in case one or more links that participate in the LAG/bundle fail.

Basic Configuration

The most basic configuration must have the following:

- Identify chassis slot.
- Specify line card type (must be an allowed card type).
- Identify XMA (MDA) slot.
- Specify XMA (MDA) (must be an allowed XMA/MDA type).
- Identify specific port to configure.

The following example displays some card configurations:

```
A:7950 XRS-20# configure card 1
A:7950 XRS-20>config>card# info
```

```
-----
card-type xcm-x20
mda 1
  mda-type cx20-10g-sfp
  no shutdown
exit
mda 2
  mda-type cx2-100g-cfp
  no shutdown
exit
no shutdown
-----
```

Common Configuration Tasks

The following sections are basic system tasks that must be performed.

- [Configuring XCMs \(Cards\) and XMA \(MDAs\) on page 85](#)
 - [Configuring XMA Access and Network Pool Parameters on page 87](#)
- [Configuring Ports on page 88](#)
 - [Configuring Port Pool Parameters on page 88](#)
 - [Configuring Ethernet Port Parameters on page 92](#)
 - [Configuring SONET/SDH Port Parameters on page 94](#)
- [Configuring LAG Parameters on page 95](#)
- [Service Management Tasks on page 97](#)

Configuring XCMs (Cards) and XMA (MDAs)

Card configurations include a chassis slot designation.

The following example displays a card and XMA (MDA) configuration:

```
A:7950 XRS-20# configure card 1
A:7950 XRS-20>config>card# info
-----
card-type xcm-x20
mda 1
  mda-type cx20-10g-sfp
  no shutdown
exit
mda 2
  mda-type cx2-100g-cfp
  no shutdown
exit
no shutdown
-----
```

Configuring Forwarding Plane Parameters

The following output provides a forwarding plane configuration.

```
*A:7950 XRS-20# configure card 1
*A:7950 XRS-20>config>card# info
-----
card-type xcm-x20
fp 1
  hi-bw-mcast-src group 0
  ingress
    mcast-path-management
      bandwidth-policy "BWP"
      no shutdown
    exit
  exit
exit
fp 2
  ingress
    mcast-path-management
      bandwidth-policy "BWP_typeF"
      no shutdown
    exit
  exit
exit
mda 1
  mda-type cx20-10g-sfp
  no shutdown
exit
mda 2
  mda-type cx2-100g-cfp
  no shutdown
exit
no shutdown
-----
```

Configuring XMA Access and Network Pool Parameters

XMA-level pools are used by ingress network queues. Network policies can be applied (optional) to create and edit QoS pool resources on egress network ports, channels, and ingress XMA. Network-queue and slope policies are configured in the `config>qos` context.

The following example displays an XMA pool configuration:

```
A:ALA-B>config>card>mda# info
-----
mda-type cx20-10g-sfp
network
  egress
    pool
      slope-policy "B"
    exit
  exit
exit
access
  ingress
    pool
      resv-cbs 50
      slope-policy "A"
    exit
  exit
exit
-----
A:ALA-B>config>card>mda#
```

Configuring Ports

This section provides the CLI syntax and examples to configure the following:

- [Configuring Port Pool Parameters on page 88](#)
 - [Changing Hybrid-Buffer-Allocation on page 91](#)
 - [Configuring Ethernet Port Parameters on page 92](#)
 - [Configuring SONET/SDH Port Parameters on page 94](#)
-

Configuring Port Pool Parameters

The buffer space is portioned out on a per port basis. Each port gets an amount of buffering which is its fair-share based on the port's bandwidth compared to the overall active bandwidth.

This mechanism takes the buffer space available and divides it into a portion for each port based on the ports active bandwidth relative to the amount of active bandwidth for all ports associated with the buffer space. An active port is considered to be any port that has an active queue associated. Once a queue is created for the port, the system will allocate the appropriate amount of buffer space to the port. This process is independently performed for both ingress and egress.

Normally, the amount of active bandwidth is considered as opposed to total potential bandwidth for the port when determining the ports fair share. If a port is channelized and not all bandwidth is allocated, only the bandwidth represented by the configured channels with queues configured is counted towards the bandwidth represented by the port. Based on the above, the number of buffers managed by a port may change due to queue creation and deletion.

After the active bandwidth is calculated for the port, the result may be modified through the use of the 'ing-percentage-of-rate' and 'egr-percent-of-rate' commands. The default value of each is 100% which allows the system to use all of the ports active bandwidth when deciding the relative amount of buffer space to allocate to the port. When the value is explicitly modified, the active bandwidth on the port is changed according to the specified percentage. If a value of 50% is given, the ports active bandwidth will be multiplied by .5, if a value of 150% is given, the active bandwidth will be multiplied by 1.5. This capability is independent of named pool mode. The ports rate percentage parameters may be modified at any time.

Examples:

1. To modify (in this example, to double) the size of buffer allocated on ingress for a port:

CLI Syntax: B:SR7-10# configure port 1/2/1 modify-buffer-allocation-rate
ing-percentage-of-rate 200

2. To modify (in this example, to double) the size of buffer allocated on ingress for a port:

CLI Syntax: B:SR7-10# configure port 1/2/1 modify-buffer-allocation-rate egr-percentage-of-rate 200

Buffer allocation has the following characteristics:

- Each port manages a buffer according to its active bandwidth (ports with equal active bandwidth get the same buffer size).
- An access port has 2 default pools created: access-ingress and access-egress.
- A network port has 2 default pools created: ingress-MDA (common pool for all ingress network ports) and network-egress.
- All queues defined for a port get buffers from the same buffer pool.

The following example displays port pool configurations:

```
A:ALA-B>config>port# info
-----
    access
      egress
        pool
          slope-policy "slopePolicy1"
        exit
      exit
    exit
  network
    egress
      pool
        slope-policy "slopePolicy2"
      exit
    exit
  exit
no shutdown
-----
```

Configuring CBS over subscription example:

```
*A:Dut-T>config>port# info
-----
    access
      ingress
        pool
          amber-alarm-threshold 10
          resv-cbs 10 amber-alarm-action step 1 max 30
        exit
      exit
    exit
  ethernet
    mode access
    encap-type dot1q
-----
```

Configuring Ports

```
exit  
no shutdown
```

Changing Hybrid-Buffer-Allocation

The following example displays a hybrid-buffer-allocation value change (from default) for ingress. In this example, the network-egress buffer pool is two times the size of the access-egress.

```
A:SR>config>port>hybrid-buffer-allocation# info
-----
egr-weight access 20 network 40
```

Configuring Ethernet Port Parameters

Ethernet Network Port

A network port is network facing and participates in the service provider transport or infrastructure network processes.

The following example displays a network port configuration:

```
A:ALA-B>config>port# info
-----
      description "Ethernet network port"
      ethernet
      exit
      no shutdown
-----
A:ALA-B>config>port#
```

Ethernet Access Port

Services are configured on access ports used for customer-facing traffic. If a Service Access Port (SAP) is to be configured on a port, it must be configured as access mode. When a port is configured for access mode, the appropriate encapsulation type can be specified to distinguish the services on the port. Once a port has been configured for access mode, multiple services may be configured on the port.

```
A:ALA-A>config>port# info
-----
description "Ethernet access port"
access
  egress
    pool
      slope-policy "slopePolicy1"
    exit
  exit
exit
network
  egress
    pool
      slope-policy "slopePolicy2"
    exit
  exit
exit
ethernet
  mode access
  encap-type dot1q
exit
no shutdown
-----
A:ALA-A>config>port#
```

Configuring 802.1x Authentication Port Parameters

The following example displays an 802.1x port configuration:

```
A:ALA-A>config>port>ethernet>dot1x# info detail
-----
      port-control auto
      radius-plcy dot1xpolicy
      re-authentication
      re-auth-period 3600
      max-auth-req 2
      transmit-period 30
      quiet-period 60
      supplicant-timeout 30
      server-timeout 30
      no tunneling
-----
```

Configuring SONET/SDH Port Parameters

When an ethernet port is configured in WAN mode (xgig wan), you can change certain SONET/SDH parameters to reflect the SONET/SDH requirements for this port. See [SONET/SDH Interfaces on page 246](#) for details.

The following CLI output provides an example of some SONET/SDH configuration for a WAN PHY ethernet port.

```
*A:7950 XRS-20>config>port# info
-----
      shutdown
      ethernet
         xgig wan
      exit
      sonet-sdh
         tx-dus
         suppress-lo-alarm
         threshold ber-sd rate 4
         section-trace increment-z0
         path
            trace-string "hello"
            report-alarm pais
            signal-label 0x20
         exit
      exit
-----
```

Configuring LAG Parameters

LAG configurations should include at least two ports. Other considerations include:

- A maximum of 64 ports (depending on IOM type, chassis-mode and lag-id) can be included in a LAG. All ports in the LAG must share the port characteristics inherited from the primary port.
- Autonegotiation must be disabled or set limited mode for ports that are part of a LAG to guarantee a specific port speed.
- Ports in a LAG must be configured as full duplex.

The following example displays LAG configuration output:

```
A:ALA-A>config>lag# info detail
-----
description "LAG2"
mac 04:68:ff:00:00:01
port 1/1/1
port 1/3/1
port 1/5/1
port 1/7/1
port 1/9/1
dynamic-cost
port-threshold 4 action down
-----
A:ALA-A>config>lag#
```

Configuring BFD on LAG Links

BFD can be configured under the LAG context to create and establish the micro-BFD session per link after the LAG and associated links have been configured. An IP interface must be associated with the LAG or a VLAN within the LAG, if dot1q encapsulation is used, before the micro-BFD sessions can be established.

Complete the following steps to enable and configure BFD over the individual LAG links:

- Enable BFD within the LAG context, which also enters the CLI into the BFD context
- Configure the address family which is to be used for the micro BFD sessions. Only one address family can be configured per LAG
- Configured the local-IP address to be used for the BFD sessions
- Configure the remote-IP address to be used for the BFD sessions

When configuring the local and remote IP address for the BFD over LAG link sessions, the *local-ip* parameter should always match an IP address associated with the IP interface to which this LAG is bound. In addition, the *remote-ip* parameter should match an IP address on the remote

system and should also be in the same subnet as the *local-ip* address. If the LAG bundle is re-associated with a different IP interface, the *local-ip* and *remote-ip* parameters should be modified to match the new IP subnet.

The optional parameters that may be configured for the BFD over LAG links include:

- Transmit Interval
- Receive Interval
- Multiplier
- Max-Wait-for-Up-Time - This parameter controls how long a link will remain active if BFD is enabled after the LAG and associated links are active and in a forwarding state.
- Max-Time-Admin-Down - This parameter controls how long the system will wait before bringing the associated link out of service if an admin down message is received from the far-end.

The following is an example configuration:

```
*A:Dut-C>config>lag# info
-----
bfd
  family ipv4
    local-ip-address 10.120.1.2
    receive-interval 1000
    remote-ip-address 10.120.1.1
    transmit-interval 1000
    no shutdown
  exit
exit
no shutdown
```

Service Management Tasks

This section discusses basic procedures of the following service management tasks:

- [Modifying a Card Type on page 98](#)
 - [Deleting a Card on page 99](#)
 - [Deleting Port Parameters on page 99](#)
-

Modifying or Deleting an XMA (MDA)

To change an XMA/MDA type already provisioned for a specific slot/card, first you must shut down the slot/MDA/port configuration and then delete the MDA from the configuration.

Note: To modify or delete XMAs, use the MDA command structure.

Use the following CLI syntax to modify an MDA:

CLI Syntax: `config> port port-id
shutdown`

CLI Syntax: `config> card slot-number
shutdown
[no] mda mda-number
[no] mda-type mda-type
[no] hi-bw-mcast-src [alarm] [group group-id]
shutdown`

Modifying a Card Type

In order to modify the card type already provisioned for a specific slot, you must shutdown existing port configurations and shutdown and remove all XMA configurations. Use the following CLI syntax to modify a card type already provisioned for a specific slot:

CLI Syntax: `config> port port-id
[no] shutdown`

CLI Syntax: `config> card slot-number
mda mda-number
[no] mda-type mda-type
[no] shutdown`

Deleting a Card

In order to delete the card type provisioned for a specific slot, you must shutdown existing port configurations and shutdown and remove all XMA configurations. Use the following CLI syntax to delete a card provisioned for a specific slot:

CLI Syntax: `config> port port-id
shutdown`

CLI Syntax: `config> card slot-number
card-type card-type
mda mda-number
no mda-type mda-type
no shutdown`

Deleting Port Parameters

Use the following CLI syntax to delete a port provisioned for a specific card:

CLI Syntax: `config>port port-id
shutdown
no port port-id`

XMA and Port Command Reference

Command Hierarchies

Card and MDA Configuration Commands

- [Hardware Commands on page 102](#)
 - [Card Commands on page 102](#)
 - [XMA/MDA Commands on page 102](#)
 - [Forwarding Plane \(FP\) Commands on page 105](#)
- [Port Configuration Commands on page 107](#)
- [Ethernet Commands on page 109](#)
- [SONET/SDH Commands on page 114](#)
- [LAG Commands on page 115](#)
- [Ethernet Ring Commands on page 117](#)
- [Multi-Chassis Redundancy Commands on page 118](#)
- [Show Commands on page 120](#)
- [Clear Commands on page 121](#)
- [Debug Commands on page 121](#)
- [Tools Commands on page 122](#)

Hardware Commands

- config
 - [no] **card** *slot-number*
 - **card-type** *card-type*
 - **no card-type**
 - [no] **fail-on-error**
 -

XMA/MDA Commands

- [no] **card** *slot-number*
 - [no] **mda** *mda-slot*
 - **access**
 - **egress**
 - [no] **pool** [*name*]
 - **amber-alarm-threshold** *percentage*
 - **no amber-alarm-threshold**
 - **red-alarm-threshold** *percentage*
 - **no red-alarm-threshold**
 - **resv-cbs** *percent-or-default* **amber-alarm-action**
 - **step percent max** [1..100]
 - **resv-cbs** *percent-or-default*
 - **no resv-cbs**
 - **slope-policy** *name*
 - **no slope-policy**
 - **ingress**
 - [no] **pool** [*name*]
 - **amber-alarm-threshold** *percentage*
 - **no amber-alarm-threshold**
 - **red-alarm-threshold** *percentage*
 - **no red-alarm-threshold**
 - **resv-cbs** *percent-or-default* **amber-alarm-action**
 - **step percent max** [1..100]
 - **resv-cbs** *percent-or-default*
 - **no resv-cbs**
 - **slope-policy** *name*
 - **no slope-policy**
 -
 - **egress-xpl**
 - **threshold** *threshold*
 - **window** *window*
 - [no] **fail-on-error**
 - **mda-type** *mda-type*
 - **no mda-type**
 - **power-priority-level** 1..200
 - **network**
 - **egress**
 - [no] **pool** [*name*]
 - **amber-alarm-threshold** *percentage*
 - **no amber-alarm-threshold**
 - **red-alarm-threshold** *percentage*
 - **no red-alarm-threshold**
 - **resv-cbs** *percent-or-default* **amber-alarm-action**
 - **step percent max** [1..100]
 - **resv-cbs** *percent-or-default*

- **no resv-cbs**
- **slope-policy** *name*
- **no slope-policy**
- **ingress**
 - **[no] pool** [*name*]
 - **amber-alarm-threshold** *percentage*
 - **no amber-alarm-threshold**
 - **red-alarm-threshold** *percentage*
 - **no red-alarm-threshold**
 - **resv-cbs** *percent-or-default* **amber-alarm-action** **step** *percent* **max** [1..100]
 - **resv-cbs** *percent-or-default*
 - **no resv-cbs**
 - **slope-policy** *name*
 - **no slope-policy**
 - **queue-policy** *name*
 - **no queue-policy**
- **[no] shutdown**
- **[no] sync-e**
- **[no] shutdown**
-

Power Commands

- config**
 - **system**
 - **power-management**
 - **mode** [none|basic|advanced]
 - **power-safety-level** %
 - **power safety-alert** *value in watts*
 - **peq** *peq-slot*
 - **[no] peq-type** *peq-type*
 - **[no] shutdown**

Virtual Scheduler Commands

- [no] **card** *slot-number*
- [no] **mda** *mda-slot*
- **virtual-scheduler-adjustment**
 - **rate-calc-min-int** [**fast-queue** *percent-of-default*] [**slow-queue** *percent-of-default*]
 - **no rate-calc-min-int**
 - **sched-run-min-int** *percent-of-default*
 - **no sched-run-min-int**
 - **task-scheduling-int** *percent-of-default*
 - **no task-scheduling-int**
 - **slow-queue-thresh** *kilobits-per-second*
 - **no slow-queue-thresh**

Forwarding Plane (FP) Commands

```

config
  — card
    — fp [fp-number]
      — dist-cpu-protection policy-name
      — no dist-cpu-protection
      — egress
      — wred-queue-control
        — buffer-allocation min percentage max percentage
        — no buffer-allocation
        — resv-cbs min percentage max percentage
        — no resv-cbs
        — [no] shutdown
        — slope-policy slope-policy-name
        — no slope-policy
      — hi-bw-mcast-src [alarm] [group group-id] [default-paths-only]
      — no hi-bw-mcast-src
      — ingress
        — access
          — queue-group queue-group-name instance instance-id
            [create]
              — accounting-policy policy-name
              — no accounting-policy
              — [no] collect-stats
              — description long-description-string
              — no description
              — policer-control-policy policy-name
              — no policer-control-policy
                — max-rate {rate | max}
                — priority-mbs-thresholds
                  — min-thresh-separation size [bytes | kilo-
                    bytes]
                  — [no] priority level
                  — mbs-contribution [bytes | kilobytes]
              — [no] policer-override
              — policer policer-id [create]
              — no policer policer-id
              — stat-mode {no-stats | minimal | offered-profile-
                no-cir | offered-priority-no-cir | offered-limited-
                profile-cir | offered-profile-cir | offered-priority-
                cir|offered-total-cir | offered-profile-capped-cir |
                offered-limited-capped-cir}
              — no stat-mode
              — rate {max | kilobits-per-second} [cir {max | kilo-
                bits-per-second}]
              — no rate
              — mbs {size [bytes | kilobytes] | default}
              — no mbs
              — max or 0—2000000000cbs {size [bytes | kilobytes]
                | default}
              — no max or 0—2000000000cbs
              — packet-byte-offset {add bytes | subtract bytes}
              — no packet-byte-offset
            — ingress-buffer-allocation hundredths-of-a-percent

```

- **no ingress-buffer-allocation**
- **mcast-path-management**
 - **bandwidth-policy** *policy-name*
 - **no bandwidth-policy**
 - **[no] shutdown**
- **network**
 - **queue-group** *queue-group-name* **instance** *instance-id*
 - **no queue-group**
 - **accounting-policy** *acct-policy-id*
 - **no accounting-policy**
 - **[no] collect-stats**
 - **description** *description-string*
 - **no description**
 - **policer-control-policy** *policy-name*
 - **no policer-control-policy**
 - **priority-mbs-thresholds**
 - **min-thresh-separation** **size** [bytes | kilobytes]
 - **[no] priority** **level**
 - **mbs-contribution** **size** [bytes | kilobytes]
 - **[no] policer-override**
 - **policer** *policer-id* [create]
 - **no policer** *policer-id*
 - **stat-mode** {no-stats | minimal | offered-profile-no-cir | offered-priority-no-cir | offered-limited-profile-cir | offered-profile-cir | offered-priority-cir|offered-total-cir | offered-profile-capped-cir | offered-limited-capped-cir}
 - **no stat-mode**
 - **rate** {max | kilobits-per-second} [cir {max | kilobits-per-second}]
 - **no rate**
 - **mbs** {size [bytes | kilobytes] | default}
 - **no mbs**
 - **max or 0—2000000000cbs** {size [bytes | kilobytes] | default}
 - **no max or 0—2000000000cbs**
 - **packet-byte-offset**{add bytes | subtract bytes}
 - **packet-byte-offset**
 - **[no] stable-pool-sizing**
 - **mda**
 - **ingress**

tools

 - **dump**
 - **mcast-path-mgr**
 - **cpm**

Port Configuration Commands

```

config
  — port {port-id}
  — no port port-id
    — access
      — egress
        — [no] pool [name]
          — amber-alarm-threshold percentage
          — no amber-alarm-threshold
          — red-alarm-threshold percentage
          — no red-alarm-threshold
          — resv-cbs percent-or-default amber-alarm-action step percent
             max [1..100]
          — resv-cbs percent-or-default
          — no resv-cbs
          — slope-policy name
          — no slope-policy
        — ingress
          — [no] pool [name]
            — amber-alarm-threshold percentage
            — no amber-alarm-threshold
            — red-alarm-threshold percentage
            — no red-alarm-threshold
            — resv-cbs percent-or-default amber-alarm-action step percent
               max [1..100]
            — resv-cbs percent-or-default
            — no resv-cbs
            — slope-policy name
            — no slope-policy
      — [no] ddm-events
      — description long-description-string
      — no description
      — ethernet
        — network
          — -50000 50000-25500-50000 500002000queue-group queue-group-
             name instance instance-id
            — [no] agg-rate
              — rate {max | rate}
              — no rate
              — [no] limit-unused-bandwidth
            — xgig {lan | wan}
          — hybrid-buffer-allocation
            — ing-weight access access-weight network network-weight
            — no ing-weight
            — egr-weight access access-weight network network-weight
            — no egr-weight
          — modify-buffer-allocation-rate
            — ing-percentage-of-rate rate-percentage
            — no ing-percentage-of-rate
            — egr-percentage-of-rate rate-percentage
            — no egr-percentage-of-rate
          — network
            — egress

```

- **[no] pool** *[name]*
 - **amber-alarm-threshold** *percentage*
 - **no amber-alarm-threshold**
 - **red-alarm-threshold** *percentage*
 - **no red-alarm-threshold**
 - **resv-cbs** *percent-or-default* **amber-alarm-action step** *percent*
max [1..100]
 - **resv-cbs** *percent-or-default*
 - **no resv-cbs**
 - **slope-policy** *name*
 - **no slope-policy**
- **[no] shutdown**
- **ethernet**

Ethernet Commands

```

config
  — [no] port {port-id}
    — ethernet
      — access
        — egress
          — queue-group queue-group-name [instance instance-id]
          — no queue-group queue-group-name
            — accounting-policy acct-policy-id
            — no accounting-policy
            — [no] agg-rate
            — [no] limit-unused-bandwidth
            — [no] queue-frame-based-accounting
            — rate {max | rate}
            — no rate
            — [no] collect-stats
            — description description-string
            — no description
            — queue-overrides
              — queue queue-id [create]
              — no queue queue-id
                — parent [[weight weight] [cir-weight cir-weight]]
                — no parent
                — adaptation-rule [pir {max | min | closest}]
                [cir {max | min | closest}]
                — no adaptation-rule
                — burst-limit {default | size [byte | kilo-byte]}
                — no burst-limit
                — cbs size-in-kbytes
                — no cbs
                — high-prio-only percent
                — no high-prio-only
                — mbs size-in-kbytes
                — no mbs
                — rate pir-rate [cir cir-rate]
                — no rate
            — scheduler-policy scheduler-policy-name
            — no scheduler-policy
          — scheduler-policy
          — policer-control-policy
          — no policer-control-policy
          — vport name [create]
          — no vport name
            — agg-rate agg-rate
            — [no] agg-rate
            — rate {max | rate}
            — no rate
            — [no] limit-unused-bandwidth
            — description description-string
            — no description
            — [no] egress-rate-modify
            — host-match dest description-string [create]

```

- **no host-match** *destination-string*
- **port-scheduler-policy** *port-scheduler-policy-name*
- **no port-scheduler-policy**
- **scheduler-policy** *scheduler-policy-name*
- **no scheduler-policy**
- **ingress**
 - **queue-group** *queue-group-name* [**create**]
 - **no queue-group** *queue-group-name*
 - **accounting-policy** *acct-policy-id*
 - **no accounting-policy**
 - **[no] collect-stats**
 - **description** *description-string*
 - **no description**
 - **queue-overrides**
 - **queue** *queue-id* [**create**]
 - **no queue** *queue-id*
 - **adaptation-rule** [**pir** {**max** | **min** | **closest**}] [**cir** {**max** | **min** | **closest**}]
 - **no adaptation-rule**
 - **burst-limit** {**default** | **size** [**byte** | **kilo-byte**]}
 - **no burst-limit**
 - **cbs** *size-in-kbytes*
 - **no cbs**
 - **high-prio-only** *percent*
 - **no high-prio-only**
 - **mbs** *size-in-kbytes*
 - **no mbs**
 - **rate** *pir-rate* [**cir** *cir-rate*]
 - **no rate**
 - **scheduler-policy** *scheduler-policy-name*
 - **no scheduler-policy**
- **autonegotiate** [**limited**]
- **no autonegotiate**
- **crc-monitor**
 - **[no] sd-threshold** *N* [**multiplier** *M*]
 - **[no] sf-threshold** *N* [**multiplier** *M*]
 - **[no] window-size** *W*
- **dot1q-etype** *0x0600..0xffff*
- **no dot1q-etype**
- **dot1x**
 - **max-auth-req** *max-auth-request*
 - **port-control** {**auto** | **force-auth** | **force-unauth**}
 - **quiet-period** *seconds*
 - **radius-plcy** *name*
 - **no radius-plcy**
 - **re-auth-period** *seconds*
 - **no re-auth-period**
 - **[no] re-authentication**
 - **server-timeout** *seconds*
 - **no server-timeout**
 - **supplicant-timeout** *seconds*
 - **no supplicant-timeout**
 - **transmit-period** *seconds*
 - **no transmit-period**

- **tunneling**
- **no tunneling**
- **[no] down-on-internal-error**
- **down-when-looped**
 - **keep-alive** *timer*
 - **no keep-alive**
 - **retry-timeout** *timer*
 - **no retry-timeout**
 - **[no] shutdown**
 - **[no] use-broadcast-address**
- **efm-oam**
 - **[no] accept-remote-loopback**
 - **[no] grace-tx-enable**
 - **hold-time** *time-value*
 - **no hold-time**
 - **[no] ignore-efm-state**
 - **mode** {**active** | **passive**}
 - **[no] shutdown**
 - **[no] transmit-interval** *interval* [**multiplier** *multiplier*]
 - **[no] tunneling**
- **egress**
 - **[no] exp-secondary-shaper**
 - **rate** {**max** | *kilobits-per-second*}
 - **no rate**
 - **class** *class-number* **rate** {*kilobits-per-second* | **max**} [**monitor-threshold** *size-in-kilobytes*]
 - **no class**
 - **low-burst-max-class** *class*
 - **no low-burst-max-class**
- **egress-rate** *sub-rate*
- **no egress-rate**
- **[no] egress-scheduler-override**
 - **level** *priority-level* **rate** *pir-rate* [**cir** *cir-rate*]
 - **no level** *priority-level*
 - **max-rate** *rate*
 - **no max-rate**
- **egress-scheduler-policy** *port-scheduler-policy-name*
- **no egress-scheduler-policy**
- **elmi**
 - **mode** {**none**|**uni-n**}
 - **n393** [2..10]
 - **no n393**
 - **t391** [5..30]
 - **no t391**
 - **t392** [5..30]
 - **no t392**
- **encap-type**
- **encap-type** {**dot1q** | **null** | **qinq**}
- **no encap-type**
- **eth-cfm**
 - **[no] mep** *mep-id* **domain** *md-index* **association** *ma-index* [**vlan** *vlan-id*]
 - **[no] ais-enable**
 - **client-meg-level** [*level* [*level* ...]]
 - **no client-meg-level**
 - **interval** {1|60}

- **no interval**
- **priority** *priority-value*
- **no priority**
- **[no] ccm-enable**
- **ccm-ltm-priority** *priority*
- **no ccm-ltm-priority**
- **ccm-padding-size** *ccm-padding*
- **no ccm-padding-size**
- **ccm-tlv-ignore** [*port-status*] [*interface-status*]
- **no ccm-tlv-ignore**
- **description** *description-string*
- **no description**
- **[no] eth-test-enable**
 - **bit-error-threshold** *bit-errors*
 - **test-pattern** {*all-zeros*|*all-ones*} [*crc-enable*]
 - **no test-pattern**
- **[no] facility-fault**
- **low-priority-defect** {*allDef*|*macRemErrXcon*|*remErrXcon*|*errXcon*|*xcon*|*noXcon*}
- **mac-address** *mac-address*
- **no mac-address**
- **one-way-delay-threshold** *seconds*
- **[no] shutdown**
- **hold-time** {[*up hold-time up*] [*down hold-time down*] [*seconds*|*centiseconds*]}
- **no hold-time**
- **ingress-rate** *ingress-rate*
- **no ingress-rate**
- **[no] lacp-tunnel**
- **lldp**
 - **dest-mac** {*nearest-bridge* | *nearest-non-tpmr* | *nearest-customer*}
 - **admin-status** {*rx* | *tx* | *tx-rx* | *disabled*}
 - **[no] notification**
 - **tx-mgmt-address** [*system*]
 - **no tx-mgmt-address**
 - **tx-tlvs** [*port-desc*] [*sys-name*] [*sys-desc*] [*sys-cap*]
 - **no tx-tlvs**
- **load-balancing-algorithm** *option*
- **no load-balancing-algorithm**
- **mac** *ieee-address*
- **no mac**
- **mode** {*access* | *network* | *hybrid*}
- **no mode**
- **mtu** *mtu-bytes*
- **no mtu**
- **network**
 - **accounting-policy** *policy-id*
 - **no accounting-policy**
 - **[no] collect-stats**
 - **egress**
 - **queue-group** *queue-group-name* [*instance instance id*] [*create*]
 - **no queue-group** *queue-group-name*
 - **accounting-policy** *acct-policy-id*
 - **no accounting-policy**

- **agg-rate** *kilobits-per-second* [**queue-frame-based-accounting**]
- **no agg-rate**
- **[no] collect-stats**
- **description** *description-string*
- **no description**
- **host-match dest** *destination-string* [**create**]
- **no host-match dest** *destination-string*
- **queue-overrides**
 - **queue** *queue-id* [**create**]
 - **no queue** *queue-id*
 - **adaptation-rule** [**pir** {**max** | **min** | **closest**}] [**cir** {**max** | **min** | **closest**}]
 - **no adaptation-rule**
 - **burst-limit**
 - **[no] burst-limit**
 - **cbs** *size-in-kbytes*
 - **no cbs**
 - **high-prio-only** *percent*
 - **no high-prio-only**
 - **mbs** *size-in-kbytes*
 - **no mbs**
 - **rate** *pir-rate* [**cir** *cir-rate*]
 - **no rate**
- **scheduler-policy** *scheduler-policy-name*
- **no scheduler-policy**
- **policer-control-policy** *policy-name*
 - **queue-policy** *name*
 - **no queue-policy**
- **pbb-etype** {**0x0600..0xffff**}
- **no pbb-etype**
- **qinq-etype** {**0x0600..0xffff**}
- **no qinq-etype**
- **[no] report-alarm** [**signal-fail**] [**remote**] [**local**] [**no-frame-lock**]
- **[no] single-fiber**
- **speed** {**10** | **100** | **1000**}
- **ssm**
 - **[no] shutdown**
 - **code-type** {**sonet** | **sdh**}
 - **no code-type**
 - **[no] tx-dus**
- **xgig** {**lan** | **wan**}

Interface Group Handler Commands

- ```

config
 — [no] interface-group-handler group-id
 — [no] member portid
 — threshold min
 — no threshold

```

## SONET-SDH Commands

```

config
 — [no] port {port-id}
 — sonet-sdh
 — clock-source {loop-timed | node-timed}
 — framing {sonet | sdh}
 — [no] path [sonet-sdh-index]vport name [create]
 — no vport name
 — agg-rate agg-rate
 — [no] agg-rate
 — rate {max | rate}
 — no rate
 — [no] limit-unused-bandwidth
 — [no] queue-frame-based-accounting
 — description description-string
 — no description
 — [no] egress-rate-modify
 — host-match dest description-string [create]
 — no host-match destination-string
 — port-scheduler-policy port-scheduler-policy-name
 — no port-scheduler-policydescription description
 — no description
 — [no] report-alarm [pais] [plop] [prdi] [pplm] [prei] [puneq] [plcd]
 — [no] shutdown
 — signal-label value
 — no signal-label
 — trace-string [trace-string]
 — no trace-string
 — [no] report-alarm [loc] [lais] [lrldi] [ss1f] [lb2er-sd] [lb2er-sf] [slof][slos] [lrei]
 — section-trace {increment-z0 | byte value | string string}
 — [no] suppress-lo-alarm
 — threshold {ber-sd | ber-sf} rate threshold-rate
 — no threshold {ber-sd | ber-sf}
 — [no] tx-dus

```

## LAG Commands

```

config
 — [no] lag [lag-id]
 — access
 — adapt-qos {link | distribute [include-egr-hash-cfg]}
 — [no] per-fp-egr-queuing
 — [no] per-fp-ing-queuing
 — [no] per-fp-sap-instance
 — bfd
 — family {ipv4 | ipv6}
 — [no] bfd-on-distributing-only
 — local-ip-address ip-address
 — no local-ip-address
 — max-admin-down-time [interval | infinite]
 — no max-admin-down-time
 — max-setup-time [interval | infinite]
 — no max-setup-time
 — multiplier multiplier
 — no multiplier
 — receive-interval interval
 — no receive-interval
 — remote-ip-address ip-address
 — no remote-ip-address
 — transmit-interval interval
 — no transmit-interval
 — shutdown
 — no shutdown
 — description long-description-string
 — no description
 — [no] dynamic-cost
 — encap-type {dot1q | null | qinq}
 — no encap-type
 — eth-cfm
 — [no] mep mep-id domain md-index association ma-index [vlan vlan-id]
 — [no] ais-enable
 — client-meg-level [level [level ...]]
 — no client-meg-level
 — interval {1|60}
 — no interval
 — priority priority-value
 — no priority
 — [no] ccm-enable
 — ccm-ltm-priority priority
 — no ccm-ltm-priority
 — ccm-padding-size ccm-padding
 — no ccm-padding-size
 — ccm-tlv-ignore [port-status] [interface-status]
 — no ccm-tlv-ignore
 — ccm-tlv-ignore [port-status] [interface-status]
 — no ccm-tlv-ignore
 — description description-string
 — no description
 — [no] eth-test-enable
 — bit-error-threshold bit-errors

```

- **test-pattern** {all-zeros|all-ones} [crc-enable]
- **no test-pattern**
- [no] **facility-fault**
- **low-priority-defect** {allDef|macRemErrXcon|remErrXcon|errXcon|xcon|noXcon}
- **mac-address** *mac-address*
- **no mac-address**
- **one-way-delay-threshold** *seconds*
- [no] **shutdown**
- **hold-time down** *hold-down-time*
- **no hold-time**
- **lacp** [*mode*] [**administrative-key** *admin-key*] [**system-id** *system-id*][**system-priority** *priority*]
- **lacp-xmit-interval** {slow | fast}
- **no lacp-xmit-interval**
- [no] **lacp-xmit-stdby**
- **link-map-profile** *lag-link-map-profile-id* [create]
- **no link-map-profile** *lag-link-map-profile-id*
  - **description** *description-string*
  - **no description**
  - **failure-mode** [discard | per-link-hash]
  - **no failure-mode**
  - **link** *port-id* {primary|secondary}
  - **no link**
- **mac** *ieee-address*
- **no mac**
- **mode** {access | network| hybrid}
- **no mode**
- [no] **per-link-hash**
- **port** *port-id* [*port-id* ... up to 64 total] [**priority** *priority*] [**sub-group** *sub-group-id*]
- **no port** *port-id* [*port-id* ... up to 64 total]
- **port-threshold** *value* [action {dynamic-cost | down}]
- **no port-threshold**
- **selection-criteria** {highest-count | highest-weight | best-port} [slave-to-partner] [**sub-group-hold-time** *hold-time*]
- **no selection-criteria**
- [no] **shutdown**
- **standby-signalling** {lacp | power-off}
- **no standby-signalling**

## Ethernet Ring Commands

```

config
 — eth-ring ring-id
 — no eth-ring
 — compatible-version value
 — description long-description-string
 — no description
 — guard-time time
 — revert-time time
 — ccm-hold-time { down down-timeout | up up-timeout }
 — [no] rpl-node { owner | nbr }
 — node-id mac
 — [no] sub-ring { virtual-link | non-virtual-link }
 — [no] interconnect { ring-id ring-id | vpls }
 — [no] propagate-topology-change
 — path { a | b } [[{ port-id | lag-id } raps-tag qtag[.qtag]]]
 — description long-description-string
 — [no] rpl-end
 — eth-cfm
 — [no] mep mep-id domain md-index association ma-index
 — [no] ccm-enable
 — [no] ccm-ltm-priority priority
 — [no] eth-test-enable
 — bit-error-threshold bit-errors
 — mac-address mac-address
 — one-way-delay-threshold time
 — [no] shutdown
 — [no] shutdown
 — [no] shutdown

```

## Multi-Chassis Redundancy Commands

```

config
 — redundancy
 — bgp-multi-homing
 — boot-timer seconds
 — no boot-timer
 — site-activation-timer seconds
 — no site-activation-timer
 — multi-chassis
 — [no] peer ip-address
 — authentication-key [authentication-key | hash-key] [hash | hash2]
 — no authentication-key
 — description description-string
 — no description
 — [no] mc-endpoint
 — [no] bfd-enable
 — boot-timer interval
 — no boot-timer
 — hold-on-neighbor-failure multiplier
 — no hold-on-neighbor-failure
 — keep-alive-interval interval
 — no keep-alive-interval
 — [no] passive-mode
 — [no] shutdown
 — system-priority value
 — no system-priority
 — [no] mc-lag
 — hold-on-neighbor-failure multiplier
 — no hold-on-neighbor-failure
 — keep-alive-interval interval
 — no keep-alive-interval
 — lag lag-id lACP-key admin-key system-id system-id [remote-lag remote-lag-id] system-priority system-priority source-bmac-lsb use-lACP-key
 — lag lag-id lACP-key admin-key system-id system-id [remote-lag remote-lag-id] system-priority system-priority source-bmac-lsb MAC-Lsb
 — lag lag-id lACP-key admin-key system-id system-id [remote-lag remote-lag-id] system-priority system-priority
 — lag lag-id [remote-lag remote-lag-id]
 — no lag lag-id
 — [no] shutdown
 — mc-ring
 — ring sync-tag [create]
 — no ring sync-tag
 — in-band-control-path
 — dst-ip ip-address
 — no dst-ip
 — interface ip-int-name
 — no interface
 — service-id service-id
 — no service-id
 — [no] path-b
 — [no] range vlan-range

```

- [no] **path-excl**
  - [no] **range** *vlan-range*
- **ring-node** *ring-node-name* [**create**]
- **no ring-node** *ring-node-name*
  - **connectivity-verify**
    - **dst-ip** *ip-address*
    - **no dst-ip**
    - **interval** *interval*
    - **no interval**
    - **service-id** *service-id*
    - **no service-id**
    - [no] **shutdown**
    - **src-ip** *ip-address*
    - **no src-ip**
    - **src-mac** *ieee-address*
    - **no src-mac**
    - **vlan** [*vlan-encap*]
    - **no vlan**
- [no] **shutdown**
- [no] **shutdown**
- **source-address** *ip-address*
- **no source-address**
- [no] **sync**
  - [no] **igmp**
  - [no] **igmp-snooping**
  - [no] **mc-ring**
  - [no] **mld**
  - [no] **mld-snooping**
  - **port** [*port-id* | *lag-id*] [**sync-tag** *sync-tag*]
  - **no port** [*port-id* | *lag-id*]
    - **range** *encap-range* [**sync-tag** *sync-tag*]
    - **no range** *encap-range*
  - [no] **shutdown**

## Show Commands

```

show
— chassis [environment] [power-supply]
 — power-management [requirements | utilization] [detail]
— card state
— card [slot-number]
— card [slot-number] detail
— card slot-number fp [1..2] ingress queue-group mode {access|network}
— card slot-number [detail] fp [1..2] ingress queue-group queue-group-name instance [1..65535]
 mode {access|network} [statistics]
— cflowd
— elmi
 — evc [port-id [vlan vlan-id]]
 — uni [port-id]
— interface-group-handler [igh-id]
— mda slot [mda] [detail]
— pools mda-id[/port] [access-app [pool-name | service service-id | queue-group queue-group-name]]
— pools mda-id[/port] [network-app [pool-name | queue-group queue-group-name]]
— pools mda-id[/port] [direction [pool-name|service service-id | queue-group queue-group-name]]
— lag [lag-id] [detail] [statistics]
— lag [lag-id] description
— lag [lag-id] port
— lag lag-id associations
— lag lag-id bfd
— lag lag-id [detail] eth-cfm [tunnel tunnel-id]
— lag lag-id associations per-link-hash interface
— lag lag-id associations link-map-profile [link-map-profile] interface
— lag lag-id lacp-partner
— lag lag-id detail lacp-partner
— lag lag-id link-map-profile link-map-profile
— lag lag-id associations per-link-hash sap
— lag lag-id associations link-map-profile [link-map-profile] sap
— lag [lag-id] [detail] [statistics] [eth-cfm tunnel tunnel-id]
— lag lag-id associations
— megapools slot-number
— megapools slot-number fp forwarding-plane [service-id service-id] [queue-group queue-group-
 name] [ingress | egress]
—
— peq [peq-slot] [detail]
— port port-id [count] [detail]
— port port-id description
— port port-id associations
— port port-id queue-group [ingress|egress] [queue-group-name] [access|network] [{statistic|asso-
 ciations}]
— port port-id dot1x [detail]
— port port-id ethernet [efm-oam | detail]
 — dot1x [detail]
 — lldp [nearest-bridge | nearest-non-tpmr | nearest-customer] [remote-info] [detail]
— redundancy
 — multi-chassis all
 — multi-chassis mc-lag
 — multi-chassis sync
 — mc-lag peer ip-address [lag lag-id]
 — mc-lag [peer ip-address [lag lag-id]] statistics

```

- **mc-ring** peer *ip-address* statistics
- **mc-ring** peer *ip-address* [**ring** *sync-tag* [**detail** | **statistics**] ]
- **mc-ring** peer *ip-address* **ring** *sync-tag* **ring-node** [*ring-node-name* [**detail** | **statistics**] ]
- **mc-ring** global-statistics
- **system**
  - **switch-fabric** high-bandwidth-multicast

## Monitor Commands

For more information about monitor commands, refer to the 7750 SR OS Basic System Configuration Guide for command usage and CLI syntax.

### monitor

- **card** *slot-number* **fp** *fp-number* **ingress** {**access** | **network**} **queue-group** *queue-group-name* **instance** *instance-id* [**absolute**] [**interval** *seconds*] [**repeat** *repeat*] **policer** *policer-id*
- **port** *port-id* [*port-id...*(up to 5 max)] [**interval** *seconds*] [**repeat** *repeat*] [**absolute** | **rate**] [**multiclass**]
- **queue-group** *queue-group-name* **egress** *access* **egress-queue** *egress-queue-id* [**interval** *seconds*] [**repeat** *repeat*] [**absolute** | **rate**]
- **queue-group** *queue-group-name* **ingress** *access* **ingress-queue** *ingress-queue-id* [**interval** *seconds*] [**repeat** *repeat*] [**absolute** | **rate**]
- **queue-group** *queue-group-name* **egress** *network* **instance** *instance-id* [**policer** *policer-id*] [**egress-queue** *egress-queue-id*] [**interval** *seconds*] [**repeat** *repeat*] [**absolute** | **rate**]

## Clear Commands

### clear

- **card** *slot-number* **soft** [**hard-reset-unsupported-mdas**]
- **card** *slot-number* **fp** [1..2] **ingress** **mode** {**access**|**network**} **queue-group** *group-name* **instance** *instance* **statistics**
- **card** *slot-number* [**soft**]
- **lag** *lag-id* **statistics**
- **mda** *mda-id* [**statistics**]
- **port** *port-id* **statistics**
- **port** *port-id* **statistics**
- **port** *port-id* **queue-group** *queue-group-name* [**access** | **network**] {**ingress** | **egress**} [**access**|**network**] [{**statistics**|**associations**}]
- **queue-group** *queue-group-name* **egress** *access* **egress-queue** *egress-queue-id* [**interval** *seconds*] [**repeat** *repeat*] [**absolute** | **rate**]
- **queue-group** *queue-group-name* **ingress** *access* **ingress-queue** *ingress-queue-id* [**interval** *seconds*] [**repeat** *repeat*] [**absolute** | **rate**]
- **queue-group** *queue-group-name* **egress** *network* **instance** *instance-id* [**policer** *policer-id*] [**egress-queue** *egress-queue-id*] [**interval** *seconds*] [**repeat** *repeat*] [**absolute** | **rate**]

## Debug Commands

### debug

- **lag** [**lag-id** *lag-id* **port** *port-id*] [**all**]
- **lag** [**lag-id** *lag-id* **port** *port-id*] [**sm**] [**pkt**] [**cfg**] [**red**] [**iom-upd**] [**port-state**] [**timers**] [**sel-logic**] [**mc**] [**mc-pkt**]
- **no lag** [**lag-id** *lag-id*]

## Tools Commands

- tools
  - **dump**
    - **lag** *lag-id lag-id*
    - **map-to-phy-port** { **ccag** *ccag-id* | **lag** *lag-id* | **eth-tunnel** *tunnel-index* } { **isid** *isid* [ **end-isid** *isid* ] | **service** *service-id* | *svc-name* [ **end-service** *service-id* / *svc-name* ] } [ **summary** ]
    - **lag** *port-id*
    - **redundancy**
      - **multi-chassis**
        - **mc-ring**
        - **srrp-sync-data** [ **instance** *instance-id* ] [ **peer** *ip-address* ]
        - **sync-database** [ **peer** *ip-address* ] [ **port** *port-id* | *lag-id* ] [ **sync-tag** *sync-tag* ] [ **application** { **dhcps** | **igmp** | **igmp-snooping** | **mc-ring** | **srrp** | **sub-mgmt** | **mld-snooping** } ] [ **detail** ] [ **type** { **alarm-deleted** | **local-deleted** } ]
- tools
  - **perform**
    - **eth-ring**
      - **clear** *ring-id*
      - **force** *ring-id* **path** { **a** | **b** }
      - **manual** *ring-id* **path** { **a** | **b** }
    - **ima**
      - **reset** *bundle-id*
    - **set-fabric-speed** *speed*

---

## Configuration Commands

- [Generic Commands on page 123](#)
- [Card Commands on page 125](#)
- [MDA \(XMA\) Commands on page 132](#)
- [MDA/Port QoS Commands on page 138](#)
- [General Port Commands on page 143](#)
- [Ethernet Port Commands on page 154](#)
- [802.1x Port Commands on page 185](#)
- [LLDP Port Commands on page 190](#)
- [Network Port Commands on page 192](#)
- [Interface Group Handler Commands on page 194](#)
- [SONET/SDH Port Commands on page 196](#)
- [SONET/SDH Path Commands on page 200](#)
- [LAG Commands on page 203](#)
- [Multi-Chassis Redundancy Commands on page 233](#)

---

## Generic Commands

### description

**Syntax**    **description** *description-string*  
**no description**

**Context**    config>port  
 config>port>ethernet>access>egr>vport  
 config>port>ethernet>access>egr>qgrp  
 config>port>ethernet>access>ing>qgrp  
 config>port>ethernet>network>egr>qgrp  
 config>port>sonet-sdh>path  
 config>lag  
 config>lag>link>map>profile  
 config>port>ethernet>eth-cfm>mep  
 config>card>fp>ingress>access>queue-group  
 config>card>fp>ingress>network>queue-group

**Description**    This command creates a text description for a configuration context to help identify the content in the configuration file.

The **no** form of this command removes any description string from the context.

## Generic Commands

**Default** No description is associated with the configuration context.

**Parameters** *long-description-string* — The description character string. Strings can be up to 160 characters long composed of printable, 7-bit ASCII characters. If the string contains special characters (#, \$, spaces, etc.), the entire string must be enclosed within double quotes.

## shutdown

**Syntax** [no] shutdown

**Context** config>card  
config>card>mda  
config>interface-group-handler  
config>port  
config>port>ethernet  
config>port>sonet-sdh>path  
config>lag  
config>port>ethernet>eth-cfm>mep  
config>port>ethernet>efm-oam  
config>redundancy>multi-chassis>peer  
config>redundancy>mc>peer>mcr  
config>redundancy>mc>peer>mc-lag  
config>redundancy>mc>peer>mcr>ring  
config>redundancy>mc>peer>mcr>node>cv  
config>redundancy>multi-chassis>peer>sync

**Description** This command administratively disables an entity. When disabled, an entity does not change, reset, or remove any configuration settings or statistics.

The operational state of the entity is disabled as well as the operational state of any entities contained within.

The **no** form of this command administratively enables an entity.

**Special Cases** **card** — The default state for a card is **no shutdown**.

**interface group handler (IGH)** — The default state for an IGH is **shutdown**.

**mda** — The default state for a mda is **no shutdown**.

**lag** — The default state for a Link Aggregation Group (LAG) is **shutdown**.

**port** — The default state for a port is **shutdown**.

**path** — The default state for a SONET/SDH path is **shutdown**.

---

## Card Commands

### card

**Syntax**    **card** *slot-number*  
              **no card** *slot-number*

**Context**    config

**Description**    This mandatory command enables access to the XCM (card) and XMA (mda) CLI contexts.  
The **no** form of this command removes the card from the configuration. All associated ports, services, and MDAs must be shutdown.

**Default**      No cards are configured.

**Parameters**    *slot-number* — The slot number of the card in the chassis.

**Values**        1 — 10

### card-type

**Syntax**        **card-type** *card-type*  
                  **no card-type**

**Context**        config>card

**Description**    This mandatory command adds an XCM to the device configuration for the slot. The card type can be pre-provisioned, meaning that the card does not need to be installed in the chassis.

A card must be provisioned before an XMA (mda).

A card can only be provisioned in a slot that is vacant, meaning no other card can be provisioned (configured) for that particular slot. To reconfigure a slot position, use the **no** form of this command to remove the current information.

A card can only be provisioned in a slot if the card type is allowed in the slot. An error message is generated if an attempt is made to provision a card type that is not allowed.

If a card is inserted that does not match the configured card type for the slot, then a medium severity alarm is raised. The alarm is cleared when the correct card type is installed or the configuration is modified.

A high severity alarm is raised if an administratively enabled card is removed from the chassis. The alarm is cleared when the correct card type is installed or the configuration is modified. A low severity trap is issued when a card is removed that is administratively disabled.

An appropriate alarm is raised if a partial or complete card failure is detected. The alarm is cleared when the error condition ceases.

The **no** form of this command removes the card from the configuration.

**Default**        No cards are preconfigured for any slots.

## Card Commands

**Parameters** *card-type* — The type of card to be configured and installed in that slot.

**Values** xcm-x20

## fail-on-error

**Syntax** [no] fail-on-error

**Context** config>card

**Description** This command controls the behavior of the card when any one of a specific set of card level errors is encountered in the system. When the **fail-on-error** command is enabled, and any one (or more) of the specific errors is detected, then the Operational State of the card is set to Failed. This Failed state will persist until the clear card command is issued (reset) or the card is removed and re-insterted (re-seat). If the condition persists after re-seating the card, then Alcatel-Lucent support should be contacted for further investigation.

Enabling **fail-on-error** is only recommended when the network is designed to be able to route traffic around a failed card (redundant cards, nodes or other paths exist).

The list of specific errors includes:

- CHASSIS event ID# 2063 – tmnxEqCardPChipMemoryEvent
- CHASSIS event ID# 2076 – tmnxEqCardPChipCamEvent
- CHASSIS event ID# 2059 – tmnxEqCardPChipError (for ingress ethernet only)

Note that upon the detection of the event/error in the system, the reporting of the event (logs) and the **fail-on-error** behavior of the card are independent. Log event control configuration will determine whether the events are reported in logs (or SNMP traps, etc) and the **fail-on-error** configuration will determine the behavior of the card. This implies that the card can be configured to **fail-on-error** even if the events are suppressed (some may be suppressed in the system by default). In order to facilitate post-failure analysis, it is recommended to enable the reporting of the specific events/errors (configure log event-control) when **fail-on-error** is enabled.

**Default** no fail-on-error

## power-priority-level

**Syntax** power-priority-level 1—200

**Context** config>card>mda

**Description** This command sets the power priority value. An operator must assign a priority value to each XMA using a range of number from 1 to 200. The lowest number has the highest priority. The default priority is 150. The priority number range from 1 – 100 should be used for modules considered essential for system operation. Lower priority values of 101 – 200 should be used for non-essential modules.

---

## Power Commands

### mode

**Syntax** `mode [none|basic|advanced]`

**Context** `config>system>power-management`

**Description** This command sets the power mode.

*none* — Specifies that there is no management of power to modules. In this mode, no gradual shutdown of active XCMs and XMAAs is enforced. No spare capacity is reserved and any APEQ failure may result in brownouts or card failures.

*basic* — Specifies that the node will bring up as many provisioned modules (in order of priority) as possible using the N+1 algorithm. In **basic** mode the system shuts down IO cards when power capacity drops below the Power Safety Level.

*advanced* — Specifies that the operator can maintain a spare APEQ as long as possible to make it immune to the possibility of power brown-outs. In **advanced** mode, the system starts shutting down IO cards when the power capacity drops below the Power Safety Level + Max rated APEQ.

*Default* **basic** mode

### power-safety-level

**Syntax** `power-safety-level %`

**Context** `config>system>power-management`

**Description** This command sets the Power Safety Level, which is a percentage of the calculated worst case power draw value. It is set to 100% by default. Once a Power Safety Level is configured by the operator, both the Basic and Advanced modes use the Power Safety Level as a reference for calculating the power redundancy using N+1 algorithm during start up and recovery from power depression.

**Parameters** `%` — Specifies the Power Safety Level as a percentage of the calculated worst case power draw value.

### power safety-alert

**Syntax** `power safety-alert value in watts`

**Context** `config>system>power-management`

**Description** This command sets a value in watts for the Power Safety Alert .The Power Safety Alert minor alarm is generated when the system power capacity drops below the Power Safety Level (in watts) + the Power Safety Alert. This is a critical level, which when breached the system starts shutting down IO cards based on card priority.

## Power Commands

### peq

**Syntax** `peq peq-slot`

**Context** `config>system>power-management`

**Description** This command sets the APEQ slot number.

**Parameters** *peq-slot* — An identifier the APEQ slot.

**Values** 1 — 12

### peq-type

**Syntax** `[no] peq-type peq-type`

**Context** `config>system>power-management>peq`

**Description** This command sets the type of APEQ for the designated APEQ slot.  
The **no** form of the command reverts to the default setting.

**Parameters** *peq-type* — An identifier the APEQ type.

**Values** apeq-dc-2000

**Default** apeq-dc-2000

### shutdown

**Syntax** `[no] shutdown`

**Context** `config>system>power-management>peq`

**Description** This command administratively enables/disables the APEQ.

---

## Virtual Scheduler Commands

### rate-calc-min-int

**Syntax** `rate-calc-min-int [fast-queue percent-of-default] [slow-queue percent-of-default]`  
`no rate-calc-min-int`

**Context** config>card>virt-sched-adj

**Description** This command overrides the default minimum time that must elapse before a queue's offered rate may be recalculated. A minimum time between offered rate calculations is enforced to both prevent inaccurate estimation of the offered rate and excessive input to the virtual scheduler process.

In order to smooth out rapidly fluctuating offered rates, the system averages the measured offered rate with a window of previously measured offered rates. The window size is based on 4x the minimum rate calculation interval. Any previous measured offered rates within the window are used in the averaging function.

The system separates queues into fast and slow categories and maintains a separate minimum recal interval for each type. The default minimum recalculation times for each type are as follows:

#### Slow Queue

|                                    |                |
|------------------------------------|----------------|
| Minimum Rate Calculation Interval: | 0.1875 Seconds |
| Averaging Window Size:             | 0.75 Seconds   |

#### Fast Queue

|                                    |                |
|------------------------------------|----------------|
| Minimum Rate Calculation Interval: | 0.0625 Seconds |
| Averaging Window Size:             | 0.25 Seconds   |

The actual minimum rate calculation interval may be increased or decreased by using the fast-queue and/or slow-queue keywords followed by a percent value which is applied to the default interval. The default slow-queue threshold rate is 1Mbps. Once a queue is categorized as slow, its rate must rise to 1.5Mbps before being categorized as a fast queue. The categorization threshold may be modified by using the slow-queue-thresh command.

The `no rate-calc-min-int` command is used to restore the default fast queue and slow queue minimum rate calculation interval.

**Parameters** **fast-queue percent-of-default:** — The fast-queue percent-of-default parameter is optional and is used to modify the default minimum rate calculation time for “fast” queues. Defining 100.00 percent is equivalent to removing the override (restoring the default) on the fast queue minimum rate calculation time.

**Values** 0.01% to 1000.00%

**Default** 100.00%

**slow-queue percent-of-default:** — The slow-queue percent-of-default parameter is optional and is used to modify the default minimum rate calculation time for “slow” queues. Defining 100.00 percent is equivalent to removing the override (restoring the default) on the slow queue minimum rate calculation time.

**Values** 0.01% to 1000.00%

## Virtual Scheduler Commands

**Default** 100.00%

### sched-run-min-int

**Syntax** **sched-run-min-int** *percent-of-default*  
**no sched-run-min-int**

**Context** config>card>virt-sched-adj

**Description** This command is used to override the default minimum time that must elapse before a virtual scheduler may redistribute bandwidth based on changes to the offered rates of member queues. A minimum run interval is enforced to allow a minimum amount of “batching” queue changes before reacting to the changed rates. This minimum interval is beneficial since the periodic function of determining queue offered rates is performed sequentially and the interval allows a number queues rates to be determined prior to determining the distribution of bandwidth to the queues.

The default minimum scheduler run interval is 0.5 seconds. The sched-run-min-int command uses a percent value to modify the default interval.

The **no** sched-run-min-int command is used to restore the default minimum scheduler run interval for all virtual schedulers on the card.

**Parameters** *percent-of-default*: — The percent-of-default parameter is required and is used to modify the default minimum scheduler run interval for all virtual schedulers on the card. Defining 100.00 percent is equivalent to removing the override (restoring the default) for the minimum scheduler run interval.

**Values** 0.01% to 1000.00%

**Default** 100.00%

### task-scheduling-int

**Syntax** **task-scheduling-int** *percent-of-default*  
**no task-scheduling-int**

**Context** config>card>virt-sched-adj

**Description** This command is used to override the system default time between scheduling the hierarchical virtual scheduling task. By default, the system “wakes” the virtual scheduler task every 50ms; this is equivalent to five 10ms timer ticks. The task-scheduling-int command uses a percent value parameter to modify the number of timer ticks.

While the system accepts a wide range of percent values, the result is rounded to the nearest 10ms tick value. The fastest wake interval is 10ms (1 timer tick).

The **no** scheduling-int command is used to restore the default task scheduling interval of the card’s hierarchical virtual scheduler task.

**Parameters** *percent-of-default*: — The percent-of-default parameter is required and is used to modify the default task scheduling interval for the hierarchical virtual scheduling task on the card. Defining 100.00 percent is equivalent to removing the override.

**Values** 0.01% to 1000.00%

**Default** 100.00%

## slow-queue-thresh

**Syntax** **slow-queue-thresh** *kilobits-per-second*  
**no slow-queue-thresh**

**Context** config>card>virt-sched-adj

**Description** This command is used to override the system default rate threshold where queues are placed in the “slow” queue category. Slow rate queues use a different minimum rate calculation interval time than fast rate queues. The rate is determined based on the previous calculated offered rate for the queue.

The default slow queue rate is 1Mbps. The fast rate is derived by multiplying the slow rate by a factor of 1.5 resulting in a default fast rate of 1.5Mbps. The slow-queue-thresh command uses a “Kilobit-Per-Second” value to modify the default slow queue rate threshold and indirectly changes the fast queue rate threshold.

The **no** slow-queue-thresh command is used to restore the default slow queue and fast queue rate thresholds.

**Parameters** *kilobit-per-second*: — The kilobit-per-second parameter is required and is used to modify the default slow queue rate threshold. Defining a value of 0 forces all queues to be treated as fast rate. Defining a value of 1000 (1Mbps) returns the threshold to the default value and is equivalent to executing no slow-queue-thresh.

The fast queue rate threshold is derived by multiplying the new slow queue rate threshold by a factor of 1.5.

**Values** 0 to 1000000 kilobits per second

**Default** 1000 kilobits per second

---

## MDA (XMA) Commands

### mda

|                    |                                                                                                                                                               |
|--------------------|---------------------------------------------------------------------------------------------------------------------------------------------------------------|
| <b>Syntax</b>      | <b>mda</b> <i>mda-slot</i><br><b>no mda</b> <i>mda-slot</i>                                                                                                   |
| <b>Context</b>     | config>card                                                                                                                                                   |
| <b>Description</b> | This mandatory command enables access to a card's MDA CLI context to configure XMA's.                                                                         |
| <b>Default</b>     | No MDA slots are configured by default.                                                                                                                       |
| <b>Parameters</b>  | <i>mda-slot</i> — The MDA slot number to be configured. <i>Slots are numbered 1 and 2.</i> The top MDA slot is number 1, and the bottom MDA slot is number 2. |
| <b>Values</b>      | 1, 2                                                                                                                                                          |

### mda-type

|                    |                                                                                                                                                                                                                                                                                                                                                                                                                                                                                                                                                                                                                                                                                                                                                                                                                                                                                                                                                                                                                                                                                                                                                                                                                                                                                                                                                                                                                                                                                                               |
|--------------------|---------------------------------------------------------------------------------------------------------------------------------------------------------------------------------------------------------------------------------------------------------------------------------------------------------------------------------------------------------------------------------------------------------------------------------------------------------------------------------------------------------------------------------------------------------------------------------------------------------------------------------------------------------------------------------------------------------------------------------------------------------------------------------------------------------------------------------------------------------------------------------------------------------------------------------------------------------------------------------------------------------------------------------------------------------------------------------------------------------------------------------------------------------------------------------------------------------------------------------------------------------------------------------------------------------------------------------------------------------------------------------------------------------------------------------------------------------------------------------------------------------------|
| <b>Syntax</b>      | <b>mda-type</b> <i>mda-type</i><br><b>no mda-type</b>                                                                                                                                                                                                                                                                                                                                                                                                                                                                                                                                                                                                                                                                                                                                                                                                                                                                                                                                                                                                                                                                                                                                                                                                                                                                                                                                                                                                                                                         |
| <b>Context</b>     | config>card>mda                                                                                                                                                                                                                                                                                                                                                                                                                                                                                                                                                                                                                                                                                                                                                                                                                                                                                                                                                                                                                                                                                                                                                                                                                                                                                                                                                                                                                                                                                               |
| <b>Description</b> | <p>This mandatory command provisions a specific MDA (XMA) type to the device configuration for the slot. The MDA can be preprovisioned but an MDA must be provisioned before ports can be configured. Ports can be configured once the MDA is properly provisioned.</p> <p>A maximum of two MDAs can be provisioned on an XMA. Only one MDA can be provisioned per MDA slot. To modify an MDA slot, shut down all port associations.</p> <p><b>Note:</b> XMA's are provisioned using MDA commands. <i>A medium severity alarm is generated if an MDA is inserted that does not match the MDA type configured for the slot. This alarm is cleared when the correct MDA is inserted or the configuration is modified.</i></p> <p>A high severity alarm is raised when an administratively enabled MDA is removed from the chassis. <i>This alarm is cleared if the either the correct MDA type is inserted or the configuration is modified.</i> A low severity trap is issued if an MDA is removed that is administratively disabled.</p> <p>An alarm is raised if partial or complete MDA failure is detected. The alarm is cleared when the error condition ceases.</p> <p>All parameters in the MDA context remain and if non-default values are required then their configuration remains as it is on all existing MDAs.</p> <p>The <b>no</b> form of this command deletes the MDA from the configuration. The MDA must be administratively shut down before it can be deleted from the configuration.</p> |
| <b>Default</b>     | No MDA types are configured for any slots by default.                                                                                                                                                                                                                                                                                                                                                                                                                                                                                                                                                                                                                                                                                                                                                                                                                                                                                                                                                                                                                                                                                                                                                                                                                                                                                                                                                                                                                                                         |

**Parameters** *mda-type* — The type of MDA selected for the slot position.

**7950:** cx20-10g-sfp, cx2-100g-cfp

**7750 SR-c12/4:** m60-10/100eth-tx, m8-oc3-sfp, m5-1gb-sfp, m2-oc48-sfp, m20-100eth-sfp, m20-1gb-tx, m4-atmoc12/3-sfp, m20-1gb-sfp, m5-1gb-sfp-b, m4-choc3-as-sfp, c8-10/100eth-tx, c1-1gb-sfp, c2-oc12/3-sfp-b, c8-chds1, c4-ds3, c2-oc12/3-sfp, c1-choc3-ces-sfp, m1-choc12-as-sfp, m12-chds3-as, m4-chds3-as, m4-choc3-ces-sfp, m10-1gb-xp-sfp, m20-1gb-xp-sfp, m20-1gb-xp-tx

## egress-xpl

**Syntax** **egress-xpl**

**Context** configure>card>mda

**Description** This command enables the context to configure **egress-xpl** settings used by the **fail-on-error** feature.

## threshold

**Syntax** **threshold** *threshold*

**Context** configure>card>mda>egress-xpl

**Description** This command configures the Egress XPL Error Threshold value used by the **fail-on-error** feature.

**Parameters** *threshold* — Specifies an upper limit on the frequency of Egress XPL Errors that can occur on the MDA. When **fail-on-error** is enabled, if the MDA experiences more than *threshold* errors per minute for *window* minutes, the MDA will be put in the *failed* state.

*threshold* cannot be changed while fail-on-error is enabled for this MDA.

**Values** 1 - 1000000

**Default** 1000

## window

**Syntax** **window** *window*

**Context** configure>card>mda>egress-xpl

**Description** This command configures the Error Window value used by the fail-on-error feature.

**Parameters** *window* — Specifies the time (in minutes) that the MDA can experience frequent Egress XPL Errors. When **fail-on-error** is enabled, if more than *threshold* Egress XPL errors per minute occur on the MDA for <window> consecutive minutes, the MDA will be put in the *failed* state.

## MDA (XMA) Commands

*window* cannot be changed while fail-on-error is enabled for this MDA.

**Values** 1 - 1440

**Default** 60

### fail-on-error

**Syntax** [no] fail-on-error

**Context** configure>card>mda

**Description** This command enables the fail-on-error feature. If an MDA is experiencing too many Egress XPL Errors, this feature causes the MDA to fail. This can force an APS switchover or **traffic re-route**. The purpose of this feature is to avoid situations where traffic is forced to use a physical link that suffers from errors but is still technically operational.

The feature uses values configured in the config>card>mda>egress-xpl context. When this feature is enabled on a MDA, if *window* consecutive minutes pass in which the MDA experiences more than *threshold* Egress XPL Errors per minute, then the MDA will be put in the *failed* state.

The **no** form of this command disables the feature on the MDA.

### hi-bw-mcast-src

**Syntax** hi-bw-mcast-src [alarm] [group group-id]  
no hi-bw-mcast-src

**Context** config>card>mda

**Description** This command designates the MDA as a high-bandwidth IP multicast source, expecting the ingress traffic to include high-bandwidth IP multicast traffic. When configured, the system attempts to allocate a dedicated multicast switch fabric plane (MSFP) to the MDA. If a group is specified, all *MDAs in the group will share the same MSFP. If the alarm parameter is specified and the system cannot allocate a dedicated MSFP to the new group or MDA, the MDAs will be brought online and generate an event (SYSTEM: 2052 - mdaHiBw-MulticastAlarm). Similarly, if during normal operation there is a failure or removal of resources, an event will be generated if the system cannot maintain separation of MSFPs for the MDAs.*

The **no** form of the command removes the high-bandwidth IP multicast source designation from the MDA.

**Default** no hi-bw-mcast-src

**Parameters** **alarm** — Enables event generation if the MDA is required to share an MSFP with another MDA that is in a different group. MDAs within the same group sharing an MSFP will not cause this alarm.

**group group-id** — Specifies the logical MSFP group for the MDA. MDAs configured with the same *group-id* will be placed on the same MSFP.

**Values** 0 — 32 (A value of 0 removes the MDA from the group.)

**Default** By default, “none” is used, and the system will attempt to assign a unique MSFP to the MDA.

## egress

**Syntax** **egress**

**Context** config>card>mda

**Description** This command enables the context to configure egress MDA parameters.

## ingress

**Syntax** **ingress**

**Context** config>card>mda

**Description** This command enables the context to configure ingress MDA parameters.

## mcast-path-management

**Syntax** **mcast-path-management**

**Context** config>card>mda>ingress

**Description** This command enables the context to configure local MDA settings for ingress multicast path management.

## ancillary-override

**Syntax** **ancillary-override**

**Context** config>card>mda>ingress>mcast-mgmt

**Description** This command enables the context to configure ancillary path bandwidth override parameters.

## path-limit

**Syntax** **path-limit** *megabits-per-second*  
**no path-limit**

**Context** config>card>mda>ingress>mcast-mgmt>anc-override

**Description** This command overrides the path limits contained in the bandwidth policy associated with the MDA.

## MDA (XMA) Commands

The **no** form of the command removes the path limit override from an ingress multicast path and restores the path limit defined in the bandwidth policy associated with the MDA.

**Parameters** *megabits-per-second* — Specifies the path limit override to give the upper limit that multicast channels may use on each path.

**Values** ancillary-override: 1 — 5000  
primary-override: 1 — 2000  
secondary-override: 1 — 2000

## bandwidth-policy

**Syntax** **bandwidth-policy** *policy-name*  
**no bandwidth-policy**

**Context** config>card>mda>ingress>mcast-mgmt

**Description** This command specifies an existing multicast bandwidth policy. Bandwidth policies are used to manage the ingress multicast path bandwidth. Each forwarding plane supports multicast forwarding paths into the switch fabric. Bandwidth policy parameters are configured in the **config>mcast-mgmt** context.

**Parameters** *policy-name* — Specifies an existing multicast bandwidth policy.

## primary-override

**Syntax** **primary-override**

**Context** config>card>mda>ingress>mcast-mgmt

**Description** This command enables the context to configure primary path limit override parameters.

## secondary-override

**Syntax** **secondary-override**

**Context** config>card>mda>ingress>mcast-mgmt

**Description** This command enables the context to configure secondary path limit override parameters.

## sync-e

**Syntax** [no] sync-e

**Context** config>card>mda

**Description** This command enables synchronous Ethernet on the MDA. Then any port on the MDA can be used as a source port in the sync-if-timing configuration.

The **no** form of the command disables synchronous Ethernet on the MDA.

## MDA/Port QoS Commands

### access

**Syntax** `access`

**Context** `config>card>mda`  
`config>port`

**Description** This command enables the access context to configure egress and ingress pool policy parameters. On the MDA level, access egress and ingress pools are only allocated on channelized MDAs.

### network

**Syntax** `network`

**Context** `config>card>mda`  
`config>port`

**Description** This command enables the network context to configure egress and ingress pool policy parameters. On the MDA level, network egress pools are only allocated on channelized MDAs.

### egress

**Syntax** `egress`

**Context** `config>port>access`  
`config>card>mda>access`  
`config>card>mda>network`  
`config>port>network`

**Description** This command enables the context to configure egress buffer pool parameters which define the percentage of the pool buffers that are used for CBS calculations and specify the slope policy that is configured in the `config>qos>slope-policy` context.

On the MDA level, network and access egress pools are only allocated on channelized MDAs.

## ingress

**Syntax** `ingress`

**Context** `config>card>mda>access`  
`config>card>mda>network`  
`config>port>access`

**Description** This command enables the context to configure ingress buffer pool parameters which define the percentage of the pool buffers that are used for CBS calculations and specify the slope policy that is configured in the **config>qos>slope-policy** context.

On the MDA level, access ingress pools are only allocated on channelized MDAs.

## pool

**Syntax** `[no] pool [name]`

**Context** `config>card>mda>access>egress`  
`config>card>mda>access>ingress`  
`config>card>mda>network>egress`  
`config>port>access>egress`  
`config>port>access>ingress`  
`config>port>network>egress`  
`config>port>network>ingress`  
`config>port>access>uplink>egress`

**Description** This command configures pool policies.

On the MDA level, access and network egress and access ingress pools are only allocated on channelized MDAs. On the MDA level, access and network egress and access ingress pools are only allocated on channelized MDAs. Network ingress pools are allocated on the MDA level for non-channelized MDAs.

Default `default`

**Parameters** *name* — Specifies the pool name, a string up to 32 characters long composed of printable, 7-bit ASCII characters. If the string contains special characters (#, \$, spaces, etc.), the entire string must be enclosed within double quotes.

## resv-cbs

**Syntax** **resv-cbs** *percent-or-default* **amber-alarm-action** **step** *percent* **max** [1..100]  
**resv-cbs** *percent-or-default*  
**no resv-cbs**

**Context** config>port>access>egress>pool  
config>port>ethernet>network  
config>card>mda>access>egress  
config>card>mda>access>ingress  
config>card>mda>network>egress  
config>card>mda>network>ingress  
config>port>access>egress>channel>pool  
config>port>access>ingress>pool  
config>port>network>egress>pool

**Description** This command defines the percentage or specifies the sum of the pool buffers that are used as a guideline for CBS calculations for access and network ingress and egress queues. Two actions are accomplished by this command.

- A reference point is established to compare the currently assigned (provisioned) total CBS with the amount the buffer pool considers to be reserved. Based on the percentage of the pool reserved that has been provisioned, the over provisioning factor can be calculated.
- The size of the shared portion of the buffer pool is indirectly established. The shared size is important to the calculation of the instantaneous-shared-buffer-utilization and the average-shared-buffer-utilization variables used in Random Early Detection (RED) per packet slope plotting.

It is important to note that this command does not actually set aside buffers within the buffer pool for CBS reservation. The CBS value per queue only determines the point at which enqueueing packets are subject to a RED slope. Oversubscription of CBS could result in a queue operating within its CBS size and still not able to enqueue a packet due to unavailable buffers. The resv-cbs parameter can be changed at any time.

If the total pool size is 10 MB and the resv-cbs set to 5, the 'reserved size' is 500 KB.

The **no** form of this command restores the default value.

The no resv-cbs command will clear all the adaptive configurations. There cannot be any adaptive sizing enabled for default resv-cbs.

**Default** default (30%)

**Parameters** *percent-or-default* — Specifies the pool buffer size percentage.

**Values** 0 — 100, default

**amber-alarm-action step percent** — specifies the percentage step-size for the reserved CBS size of the pool. When using the default value, the adaptive CBS sizing is disabled. To enable adaptive CBS sizing, **step percent** must be set to non-default value along with the **max** parameter. When reserved CBS is default adaptive CBS sizing cannot be enabled. The reserved CBS (Committed Burst Size) defines the amount of buffer space within the pool that is not considered shared.

**Values** 1 — 100

**Default** 0

**max [1..100]** — Specifies the maximum percentage for the reserved CBS size of the pool. When using the default value, the adaptive CBS sizing is disabled. To enable adaptive CBS sizing, **max** value must be set to non-default value along with the **step percent**. When reserved CBS is default adaptive CBS sizing cannot be enabled. The reserved CBS (Committed Burst Size) defines the amount of buffer space within the pool that is not considered shared. Max reserved CBS must not be more than the reserved CBS.

**Values** 1 — 100

**Default** 0

## amber-alarm-threshold

**Syntax** **amber-alarm-threshold** *percentage*  
**no amber-alarm-threshold**

**Context** config>card>mda>access>egress>pool  
config>card>mda>access>ingress>pool  
config>card>mda>network>egress>pool  
config>card>mda>network>ingress>pool  
config>port>access>egress>pool  
config>port>access>ingress>pool  
config>port>network>egress>pool

**Description** This command configures the threshold for the amber alarm on the over-subscription allowed. Users can selectively enable amber or red alarm thresholds. But if both are enabled (non-zero) then the red alarm threshold must be greater than the amber alarm threshold. The **no** form of the command reverts to the default value.

**Default** 0

**Parameters** *percentage* — Specifies the amber alarm threshold.

**Values** 1 — 1000

## red-alarm-threshold

**Syntax** **red-alarm-threshold** *percentage*  
**no red-alarm-threshold**

**Context** config>card>mda>access>egress>pool  
config>card>mda>access>ingress>pool  
config>card>mda>network>egress>pool  
config>card>mda>network>ingress>pool  
config>port>access>egress>pool  
config>port>access>ingress>pool  
config>port>network>egress>pool

**Description** This command configures the threshold for the red alarm on the over-subscription allowed.

## MDA/Port QoS Commands

Users can selectively enable amber or red alarm thresholds. But if both are enabled (non-zero) then the red alarm threshold must be greater than the amber alarm threshold.

The **no** form of the command reverts to the default value.

**Default** 0

**Parameters** *percentage* — Specifies the amber alarm threshold.

**Values** 1 — 1000

## slope-policy

**Syntax** **slope-policy** *name*  
**no slope-policy**

**Context** config>port>access>egress>pool  
config>card>mda>access>egress  
config>card>mda>access>ingress  
config>card>mda>network>egress  
config>card>mda>network>ingress  
config>port>access>egress>channel>pool  
config>port>access>ingress>pool  
config>port>network>egress>pool

**Description** This command specifies an existing slope policy which defines high and low priority RED slope parameters and the time average factor. The policy is defined in the **config>qos>slope-policy** context.

---

## General Port Commands

### port

**Syntax** **port** *{port-id}*  
**no port** *port-id*

**Context** config

**Description** This command enables access to the context to configure ports. Before a port can be configured, the chassis slot must be provisioned with a valid card type and the MDA parameter must be provisioned with a valid MDA type. (See **card** and **mda** commands.)

**Default** No ports are configured. All ports must be explicitly configured and enabled.

**Parameters** *port-id* — Specifies the physical port ID in the *slot/mda/port* format.

### ddm-events

**Syntax** [**no**] **ddm-events**

**Context** config>port

**Description** This command enables Digital Diagnostic Monitoring (DDM) events for the port. The **no** form of the command disables DDM events.

### amplifier

**Syntax** **amplifier**

**Context** config>port>dwdm

**Description** This command enables you to tune the optical amplifier parameters.

### -50000 50000-25500-50000 500002000queue-group

**Syntax** **queue-group** *queue-group-name* **instance** *instance-id*  
**no queue-group**

**Context** config>port>ethernet>network>egress

**Description** This command is used to create a queue-group instance in the network egress context of a port. Queue-groups containing queues only or policers and queues can be instantiated. When a port is a LAG, one instance of the queue-group is instantiated on each member link.

## General Port Commands

One or more instances of the same queue-group name and/or a different queue-group name can be created in the network egress context of a port.

The queue-group-name must be unique within all network egress and access egress queue groups in the system. The queue-group instance-id must be unique within the context of the port.

The **no** version of this command deletes the queue-group instance from the network egress context of the port.

**Parameters** *queue-group-name* — Specifies the name of the queue group template up to 32 characters in length.

*instance-id* — Specifies the identification of a specific instance of the queue-group.

**Values** 1—40960

## xgig

**Syntax** **xgig** {**lan** |**wan**}

**Context** config>port>ethernet

**Description** This command configures a 10 Gbps interface to be in Local or Wide Area Network (LAN or WAN) mode. When configuring the port to be in WAN mode, you can change certain SONET/SDH parameters to reflect the SONET/SDH requirements for this port. When you configure a port for LAN mode, all SONET/SDH parameters are pre-determined and not configurable.

**Default** lan

**Parameters** **lan** — Sets the port to operate in LAN mode.

**wan** — Sets the port to operate in WAN mode.

## hybrid-buffer-allocation

**Syntax** **hybrid-buffer-allocation**

**Context** config>port

**Description** This command enables the context for configuring hybrid port buffer allocation parameters.

## ing-weight

**Syntax** **ing-weight access** *access-weight* **network** *network-weight*  
**no ing-weight**

**Context** config>port>hybrid-buffer-allocation

**Description** This command configures the sharing of the ingress buffers allocated to a hybrid port among the access and network contexts. By default, it is split equally between network and access.

The **no** form of this command restores the default values for the ingress access and network weights.

|                   |                                                                     |
|-------------------|---------------------------------------------------------------------|
| <b>Parameters</b> | <i>access-weight</i> — Specifies the access weight as an integer.   |
|                   | <b>Values</b> 0 to 100                                              |
|                   | <b>Default</b> 50                                                   |
|                   | <i>network-weight</i> — Specifies the network weight as an integer. |
|                   | <b>Values</b> 0 to 100                                              |
|                   | <b>Default</b> 50                                                   |

## egr-weight

|                    |                                                                                                                                                                                                                                                                                                      |
|--------------------|------------------------------------------------------------------------------------------------------------------------------------------------------------------------------------------------------------------------------------------------------------------------------------------------------|
| <b>Syntax</b>      | <b>egr-weight access</b> <i>access-weight</i> <b>network</b> <i>network-weight</i><br><b>no egr-weight</b>                                                                                                                                                                                           |
| <b>Context</b>     | config>port>hybrid-buffer-allocation                                                                                                                                                                                                                                                                 |
| <b>Description</b> | This command configures the sharing of the egress buffers allocated to a hybrid port among the access and network contexts. By default, it is split equally between network and access.<br>The <b>no</b> form of this command restores the default values for the egress access and network weights. |
| <b>Parameters</b>  | <i>access-weight</i> — Specifies the access weight as an integer.                                                                                                                                                                                                                                    |
|                    | <b>Values</b> 0 to 100                                                                                                                                                                                                                                                                               |
|                    | <b>Default</b> 50                                                                                                                                                                                                                                                                                    |
|                    | <i>network-weight</i> — Specifies the network weight as an integer.                                                                                                                                                                                                                                  |
|                    | <b>Values</b> 0 to 100                                                                                                                                                                                                                                                                               |
|                    | <b>Default</b> 50                                                                                                                                                                                                                                                                                    |

## modify-buffer-allocation-rate

|                    |                                                                                                                                                                                                                                                                                                                                                                                                                                                                                  |
|--------------------|----------------------------------------------------------------------------------------------------------------------------------------------------------------------------------------------------------------------------------------------------------------------------------------------------------------------------------------------------------------------------------------------------------------------------------------------------------------------------------|
| <b>Syntax</b>      | <b>modify-buffer-allocation-rate</b>                                                                                                                                                                                                                                                                                                                                                                                                                                             |
| <b>Context</b>     | config>port                                                                                                                                                                                                                                                                                                                                                                                                                                                                      |
| <b>Description</b> | This command enables the context to configure ingress and egress percentage of rate parameters. This command only applies to physical ports (for example, it will not work on APS or similar logical ports). The percentage of rate commands are used to define a percentage value that affects the amount of buffers used by ingress and egress port managed buffer space. Enter the modify-buffer-allocation-rate context when editing the port's percentage of rate commands. |

## ing-percentage-of-rate

**Syntax**    **ing-percentage-of-rate** *rate-percentage*  
**no ing-percentage-of-rate**

**Context**    config>port>modify-buffer-allocation-rate

**Description**    This command increases or decreases the active bandwidth associated with the ingress port that affects the amount of ingress buffer space managed by the port. Changing a port's active bandwidth using the ing-percentage-of-rate command is an effective means of artificially lowering the buffers managed by one ingress port and giving them to other ingress ports on the same MDA.

The ing-percentage-of-rate command accepts a percentage value that increases or decreases the active bandwidth based on the defined percentage. A value of 50% causes the active bandwidth to be reduced by 50%. A value of 150% causes the active bandwidth to be increased by 50%. Values from 1 to 1000 percent are supported.

A value of 100 (the default value) is equivalent to executing the no ing-percentage-of-rate command and restores the ingress active rate to the normal value.

**Parameters**    *rate-percentage* — The rate-percentage parameter is required and defines the percentage value used to modify the current ingress active bandwidth of the port. This does not actually change the bandwidth available on the port in any way. The defined rate-percentage is multiplied by the ingress active bandwidth of the port. A value of 150 results in an increase of 50% (1.5 x Rate).

**Values**        1 to 1000

**Default**        100 (no change to active rate)

The **no** ing-percentage-of-rate command is used to remove any artificial increase or decrease of the ingress active bandwidth used for ingress buffer space allocation to the port. The no ing-percentage-of-rate command sets rate-percentage to 100%.

## egr-percentage-of-rate

**Syntax**    **egr-percentage-of-rate** *rate-percentage*  
**no egr-percentage-of-rate**

**Context**    config>port>modify-buffer-allocation-rate

**Description**    The egr-percentage-of-rate command is used to increase or decrease the active bandwidth associated with the egress port that affects the amount of egress buffer space managed by the port. Changing a ports active bandwidth using the egr-percentage-of-rate command is an effective means of artificially lowering the buffers managed by one egress port and giving them to other egress ports on the same MDA.

The egr-percentage-of-rate command accepts a percentage value that increases or decreases the active bandwidth based on the defined percentage. A value of 50% causes the active bandwidth to be reduced by 50%. A value of 150% causes the active bandwidth to be increased by 50%. Values from 1 to 1000 percent are supported.

A value of 100 (the default value) is equivalent to executing the no egr-percentage-of-rate command and restores the egress active rate to the normal value.

**Parameters** *rate-percentage* — The rate-percentage parameter is required and defines the percentage value used to modify the current egress active bandwidth of the port. This does not actually change the bandwidth available on the port in any way. The defined rate-percentage is multiplied by the egress active bandwidth of the port. A value of 150 results in an increase of 50% (1.5 x Rate).

**Values** 1 to 1000

**Default** 100 (no change to active rate)

The **no** egr-percentage-of-rate command is used to remove any artificial increase or decrease of the egress active bandwidth used for egress buffer space allocation to the port. The no egr-percentage-of-rate command sets rate-percentage to 100%.

## egress-scheduler-override

**Syntax** **[no] egress-scheduler-override**

**Context** config>port>sonet-sdh>path  
config>port>ethernet

**Description** This command applies egress scheduler overrides. When a port scheduler is associated with an egress port, it is possible to override the following parameters:

- The **max-rate** allowed for the scheduler.
- The maximum **rate** for each priority level 8 through 1.
- The CIR associated with each priority level 8 through 1.

See the 7750 SR OS Quality of Service Guide for command syntax and usage for the **port-scheduler-policy** command.

The **no** form of this command removes all override parameters from the egress port or channel scheduler context. Once removed, the port scheduler reverts all rate parameters back to the parameters defined on the port-scheduler-policy associated with the port.

## level

**Syntax** **level** *priority-level rate pir-rate [cir cir-rate]*  
**no level** *priority-level*

**Context** config>port>ethernet>egress-scheduler-override

**Description** This command overrides the maximum and CIR rate parameters for a specific priority level on the port or channel's port scheduler instance. When the **level** command is executed for a priority level, the corresponding priority level command in the port-scheduler-policy associated with the port is ignored.

The override level command supports the keyword **max** for the **rate** and **cir** parameter.

When executing the level override command, at least the **rate** or **cir** keywords and associated parameters must be specified for the command to succeed.

The **no** form of this command removes the local port priority level rate overrides. Once removed, the port priority level will use the port scheduler policies level command for that priority level.

## General Port Commands

- Parameters** *priority-level* — Identifies which of the eight port priority levels are being overridden.
- Values** 1 — 8
- rate** *pir-rate* — Overrides the port scheduler policy's maximum level rate and requires either the **max** keyword or a rate defined in kilobits-per-second to follow.
- Values** 1 — 40000000, max
- cir** *cir-rate* — Overrides the port scheduler policy's within-cir level rate and requires either the **max** keyword or a rate defined in kilobits-per-second to follow.
- Values** 0— 40000000, max
- max** — removes any existing rate limit imposed by the port scheduler policy for the priority level allowing it to use as much total bandwidth as possible.

### max-rate

- Syntax** **max-rate** *rate*  
**no max-rate**
- Context** config>port>ethernet>egress-scheduler-override
- Description** This command overrides the **max-rate** parameter found in the port-scheduler-policy associated with the port. When a max-rate is defined at the port or channel level, the port scheduler policies max-rate parameter is ignored.
- The egress-scheduler-override **max-rate** command supports a parameter that allows the override command to restore the default of not having a rate limit on the port scheduler. This is helpful when the port scheduler policy has an explicit maximum rate defined and it is desirable to remove this limit at the port instance.
- The **no** form of this command removes the maximum rate override from the egress port or channels port scheduler context. Once removed, the max-rate parameter from the port scheduler policy associated with the port or channel will be used by the local scheduler context.
- Parameters** *rate* — Specifies the explicit maximum frame based bandwidth limit. This value overrides the QoS scheduler policy rate.
- Values** 1 — 40000000, max

### egress-scheduler-policy

- Syntax** **egress-scheduler-policy** *port-scheduler-policy-name*  
**no egress-scheduler-policy**
- Context** config>port>ethernet
- Description** This command enables the provisioning of an existing port-scheduler-policy to a port or channel.
- The egress-scheduler-override node allows for the definition of the scheduler overrides for a specific port or channel.

When a port scheduler is active on a port or channel, all queues and intermediate service schedulers on the port are subject to receiving bandwidth from the scheduler. Any queues or schedulers with port-parent associations are mapped to the appropriate port priority levels based on the port-parent command parameters. Any queues or schedulers that do not have a port-parent or valid intermediate scheduler parent defined are treated as orphaned and are handled based on the port scheduler policies default or explicit orphan behavior.

The port scheduler maximum rate and priority level rate parameters may be overridden to allow unique values separate from the port-scheduler-policy-name attached to the port or channel. Use the **egress-scheduler-override** command to specify the port or channel specific scheduling parameters.

The **no** form of this command removes a port scheduler policy from an egress port or channel. Once the scheduler policy is removed, all orphaned queues and schedulers revert to a free running state governed only by the local queue or scheduler parameters. This includes any queues or schedulers with a port-parent association.

**Parameters** *port-scheduler-policy-name* — Specifies an existing port-scheduler-policy configured in the **config>qos** context.

## elmi

**Syntax** **elmi**

**Context** config>port>ethernet

**Description** This command configures Ethernet Local Management Interface (E-LMI) parameters for the Ethernet port. E-LMI is only supported on Ethernet access ports with Dot1q encapsulation type.

## mode

**Syntax** **mode {none | uni-n}**

**Context** config>port>ethernet>elmi

**Description** This command configures the the Ethernet LMI mode.

**Default** none

**Parameters** **none** — Specifies that the E LMI mode is set to none.  
**uni-n** — Specifies that the E LMI mode is set to uni-n.

## n393

**Syntax** **n393 [2..10]**  
**no n393**

**Context** config>port>ethernet>elmi

**Description** This command configures the monitored count of consecutive errors.

## General Port Commands

**Parameters** 2 .. 10 — Specifies the monitored count of consecutive errors.

### t391

**Syntax** t391 [5..30]  
no t391

**Context** config>port>ethernet>elmi

**Description** This command configures the polling timer for UNI-C.

**Parameters** 5 ..30 — Specifies the polling timer for UNI-C.

### t392

**Syntax** t392 [5..30]  
no t392

**Context** config>port>ethernet>elmi

**Description** This command configures the polling verification timer for UNI-N.

**Parameters** 5 .. 30 — Specifies the polling verification timer for UNI-N.

### mode

**Syntax** mode {access | network | hybrid}  
no mode

**Context** config>port>ethernet

**Description** This command configures an Ethernet port for **access, network or hybrid** mode operation.

An **access** port or channel is used for customer facing traffic on which services are configured. A Service Access Point (SAP) can only be configured on an access port or channel. Once an Ethernet port has been configured for access mode, multiple services can be configured on the Ethernet port.

A network port or channel participates in the service provider transport or infrastructure network when a network mode is selected. When the network option is configured, the encaps-type cannot be configured for the port/channel.

A hybrid Ethernet port allows the combination of network and access modes of operation on a per-VLAN basis and must be configured as either dot1q or QinQ encapsulation.

When the hybrid port is configured to the dot1q encapsulation, the user configures a SAP inside a service simply by providing the SAP ID which must include the port-id value of the hybrid mode port and an unused VLAN tag value. The format is <port-id>:qtag1. A SAP of format <port-id>:\* also supported.

The user configures a network IP interface under config>router>interface>port by providing the port name which consists of the port-id of the hybrid mode port and an unused VLAN tag value. The format is <port-

*id>:qtag1*. The user must explicitly enter a valid value for *qtag1*. The *<port-id>.\** value is not supported on a network IP interface. The 4096 VLAN tag space on the port is shared among VLAN SAPs and VLAN network IP interfaces.

When the hybrid port is configured to QinQ encapsulation, the user configures a SAP inside a service simply by providing the SAP ID which must include the port-id value of the hybrid mode port and the outer and inner VLAN tag values. The format is *<port-id>:qtag1.qtag2*. A SAP of format *<port-id>: qtag1.\** is also supported. The outer VLAN tag value must not have been used to create an IP network interface on this port. In addition, the *qtag1.qtag2* value combination must not have been used by another SAP on this port.

The user configures a network IP interface under `config>router>interface>port` by providing the port name which consists of the port-id of the hybrid mode port and a VLAN tag value. The format is *<port-id>:qtag1.\**. An outer VLAN tag *qtag2* of *\** is used to create an IP network interface. In addition, the *qtag1.qtag2* value combination must not have been used on another SAP or IP network interface on this port.

The **no** form of this command restores the default.

**Default**     **network** — Configures the Ethernet port for transport network use.

**Parameters**     **network** — Configures the Ethernet port as service access.  
                       **access** — Configures the Ethernet port for transport network use.  
                       **hybrid** — Configures the Ethernet port for hybrid use.

## per-link-hash

**Syntax**     **[no] per-link-hash**

**Context**     config>lag

**Description**     When specified, **per-link-hash** sends SAP/interface traffic over a single link of a LAG auto-rebalancing as links are added/removed from a LAG.

## mac

**Syntax**     **mac *ieee-address***  
                       **no mac**

**Context**     config>port>ethernet  
                       config>lag

**Description**     This command assigns a specific MAC address to an Ethernet port, Link Aggregation Group (LAG).  
                       Only one MAC address can be assigned to a port. When multiple **mac** commands are entered, the last command overwrites the previous command. When the command is issued while the port is operational, IP will issue an ARP, if appropriate, and BPDU's are sent with the new MAC address.

The **no** form of this command returns the MAC address to the default value.

**Default**     A default MAC address is assigned by the system from the chassis MAC address pool.

**Parameters**     *ieee-address* — Specifies the 48-bit MAC address in the form aa:bb:cc:dd:ee:ff or aa-bb-cc-dd-ee-ff where

## General Port Commands

aa, bb, cc, dd, ee and ff are hexadecimal numbers. Allowed values are any non-broadcast, non-multicast MAC and non-IEEE reserved MAC addresses.

### mtu

**Syntax** **mtu** *mtu-bytes*  
**no mtu**

**Context** config>port>ethernet

**Description** This command configures the maximum payload MTU size for an Ethernet port . The Ethernet port level MTU parameter indirectly defines the largest physical packet the port can transmit or the far-end Ethernet port can receive. Packets received larger than the MTU will be discarded. Packets that cannot be fragmented at egress and exceed the MTU are discarded.

The value specified for the MTU includes the destination MAC address, source MAC address, the Ethertype or Length field and the complete Ethernet payload. The MTU value does not include the preamble, start of frame delimiter or the trailing CRC.

The **no** form of this command restores the default values.

**Default** The default MTU value depends on the (sub-)port type, mode and encapsulation and are listed in the following table:

| Type                   | Mode           | Encap Type      | Default (Bytes) |
|------------------------|----------------|-----------------|-----------------|
| 10/100, Gig, or 10GigE | Access         | null            | 1514            |
| 10/100, Gig, or 10GigE | Access         | dot1q           | 1518            |
| 10/100, Gig, or 10GigE | Access         | q-in-q          | 1522            |
| <i>SONET/SDH</i>       | <i>Network</i> | <i>ppp-auto</i> | <i>1524</i>     |

**Parameters** *mtu-bytes* — Sets the maximum allowable size of the MTU, expressed as an integer.

**Values** 512 — 9212config>port>sonet-sdh>path512 — 9208

## queue-policy

**Syntax** **queue-policy** *name*  
**no queue-policy**

**Context** config>card>mda>network>ingress

**Description** This command specifies the network-queue policy which defines queue parameters such as CBS, high priority only burst size, MBS, CIR and PIR rates, as well as forwarding-class to queue mappings. The network-queue policy is defined in the **config>qos>network-queue** context.

**Default** default

**Parameters** *name* — Specifies an existing network-queue policy name.

---

## Ethernet Port Commands

### ethernet

**Syntax** ethernet

**Context** config>port

**Description** This command enables access to the context to configure Ethernet port attributes.

This context can only be used when configuring Fast Ethernet, gigabit, or 10Gig Ethernet LAN ports on an appropriate MDA.

### mode

**Syntax** mode {access | network | hybrid}  
no mode

**Context** config>port>ethernet

**Description** This command configures an Ethernet port for access, network, or hybrid mode of operation.

An access port or channel is used for customer facing traffic on which services are configured. A Service Access Point (SAP) can only be configured on an access port or channel. When a port is configured for access mode, the appropriate encap-type must be specified to distinguish the services on the port. Once an Ethernet port, has been configured for access mode, multiple services can be configured on the Ethernet port

A network port or channel participates in the service provider transport or infrastructure network when a network mode is selected. When the network option is configured, the encap-type cannot be configured for the port/channel.

A hybrid Ethernet port allows the combination of network and access modes of operation on a per-VLAN basis and must be configured as either dot1q or QinQ encapsulation.

When the hybrid port is configured to the dot1q encapsulation, the user configures a SAP inside a service simply by providing the SAP ID which must include the port-id value of the hybrid mode port and an unused VLAN tag value. The format is <port-id>:qtag1. A SAP of format <port-id>:\* also supported.

The user configures a network IP interface under config>router>interface>port by providing the port name which consists of the port-id of the hybrid mode port and an unused VLAN tag value. The format is <port-id>:qtag1. The user must explicitly enter a valid value for qtag1. The <port-id>:\* value is not supported on a network IP interface. The 4096 VLAN tag space on the port is shared among VLAN SAPs and VLAN network IP interfaces.

When the hybrid port is configured to QinQ encapsulation, the user configures a SAP inside a service simply by providing the SAP ID which must include the port-id value of the hybrid mode port and the outer and inner VLAN tag values. The format is <port-id>:qtag1.qtag2. A SAP of format <port-id>: qtag1.\* is also supported. The outer VLAN tag value must not have been used to create an IP network interface on this port. In addition, the qtag1.qtag2 value combination must not have been used by another SAP on this port.

The user configures a network IP interface under `config>router>interface>port` by providing the port name which consists of the port-id of the hybrid mode port and a VLAN tag value. The format is `<port-id>:qtag1.*`. An outer VLAN tag `qtag2` of `*` is used to create an IP network interface. In addition, the `qtag1.qtag2` value combination must not have been used on another SAP or IP network interface on this port.

The **no** form of this command restores the default.

**Default** network — for Ethernet ports

**Parameters** **access** — Configures the Ethernet port as service access.  
**network** — Configures the Ethernet port for transport network use.  
**hybrid** — Configures the Ethernet port for hybrid use.

## access

**Syntax** access

**Context** config>port>ethernet

**Description** This command configures Ethernet access port parameters.

## egress

**Syntax** egress

**Context** config>port>ethernet>access  
 config>port>ethernet>network

**Description** This command configures Ethernet access egress port parameters.

## queue-group

**Syntax** **queue-group** *queue-group-name* [**instance** *instance-id*] [**create**]  
**no queue-group** *queue-group-name* [**instance** *instance-id*]

**Context** config>port>ethernet>access>egress  
 config>port>ethernet>access>ingress

**Description** This command creates an ingress or egress queue group on an Ethernet port. A queue group is a collection of queues identified by a group name. Queue groups created on access ports are used as an alternative queue destination for SAPs.

Within a SAP, a forwarding class may be redirected from the local SAP queue to a port queue group queue. The forwarding classes from multiple SAPs may be redirected to the same queue group which can be used to minimize the number of per-SAP queues.

Queue groups may be created on both access and network oriented ports. When the port is in access mode, the queue groups must be created within the port access node.

Within the access node, queue groups are also configured as ingress or egress. Access ingress queue groups can only be used by ingress SAP forwarding classes and only a single ingress queue group per port is supported. Multiple access egress queue groups may be created on a single port and are used by egress SAP forwarding classes. The instance-id parameter identifies different instances of the same queue group template. Creating multiple queue groups with a different instance ID but the same queue group name results in separate queue groups being created on the port. The instance-id parameter is only valid for egress queue groups on access ports.

When the queue group is created in an ingress port context, the group-name must be an existing ingress queue group template. Similarly, queue groups created in an egress port context must have a group-name of an existing egress queue group template. Two ingress queue groups with the same name cannot be created on the same port. Two egress queue groups can only be created on the same port with the same queue group template name if they have different instance-id values.

The queues defined in the template are created on the queue group. The queue parameters within the template are used as the default queue parameters for each queue in the queue group. The default queue parameters for each queue may be overridden on the queue group with specific queue parameters.

Each queue group supports the application of a scheduler-policy for the purpose of managing the queues within the group into an aggregate SLA. The queues defined within the template may be configured with parent scheduler defining the mapping of a queue to one of the schedulers within the scheduler policy. Egress queue groups also support the **agg-rate** parameter and the queues in the egress template support the port-parent command. Each command is used for configuring egress port virtual scheduling behavior.

Each queue group allows the application of an accounting policy and the ability to enable and disable collecting statistics. The statistics are derived from the queue counters on each queue within the queue group. The accounting policy defines which queue counters are collected and to which accounting file they will be written.

A queue group does not have an administrative shutdown or no shutdown command. A queue group is considered to be always on once created.

When creating a queue group, the system will attempt to allocate queue resources based on the queues defined in the queue group template. If the appropriate queue resources do not currently exist, the queue group will not be created. Ingress port queue groups do not support the shared-queuing or multipoint-shared queuing behavior.

When the queue group is created on a LAG (Link Aggregation Group), it must be created on the primary port member. The primary port member is the port with the lowest port ID based on the slot, MDA position and port number on the MDA. A queue group created on the primary LAG port will be automatically created on all other port members. If a new port is being added to a LAG with an existing queue group, the queue group must first be created on the port prior to adding the port to the LAG. If the LAG queue group has queue overrides, the queue overrides must also be defined on the port queue group prior to adding the port to the LAG.

A port queue group cannot be removed from the port when a forwarding class is currently redirected to the group. All forwarding class redirections must first be removed prior to removing the queue group.

**Default** none

**Parameters** *group-name* — The group-name parameter is required when executing the port queue-group command. The specified group-name must exist as an ingress or egress queue group template depending on the ingress

or egress context of the port queue group. Only a single queue group may be created on an ingress port. Multiple queue groups may be created on an egress port.

*instance-id* — specifies the identification of a specific instance of the egress queue-group. This parameter is only valid for egress access port queue groups.

**Values** 1 — 40960

**create** — Keyword used to associate the queue group. The create keyword requirement can be enabled/ disabled in the environment>create context.

## egress

**Syntax** **egress**

**Context** config>port>ethernet

This command configures Ethernet egress port parameters.

## ingress

**Syntax** **ingress**

**Context** config>port>ethernet>access

**Description** This command configures Ethernet access ingress port parameters.

## queue-group

**Syntax** **queue-group** *queue-group-name* [**instance** *instance-id*] [**create**]  
**no queue-group** *queue-group-name*

**Context** config>port>ethernet>access>egr  
config>port>ethernet>access>ing

**Description** This command creates an ingress or egress queue group on an Ethernet port. A queue group is a collection of queues identified by a group name. Queue groups created on access ports are used as an alternative queue destination for SAPs.

Within a SAP, a forwarding class may be redirected from the local SAP queue to a port queue group queue. The forwarding classes from multiple SAPs may be redirected to the same queue group which can be used to minimize the number of per-SAP queues.

Queue groups may be created on both access and network oriented ports. When the port is in access mode, the queue groups must be created within the port access node.

Within the access node, queue groups are also configured as ingress or egress. Access ingress queue groups can only be used by ingress SAP forwarding classes and only a single ingress queue group per port is supported. Multiple access egress queue groups may be created on a single port and are used by egress SAP forwarding classes. The instance-id parameter identifies different instances of the same queue group template.

## Ethernet Port Commands

Creating multiple queue groups with a different instance ID but the same queue group name results in separate queue groups being created on the port. The instance-id parameter is only valid for egress queue groups on access ports.

When the queue group is created in an ingress port context, the group-name must be an existing ingress queue group template. Similarly, queue groups created in an egress port context must have a group-name of an existing egress queue group template. Two ingress queue groups with the same name cannot be created on the same port. Two egress queue groups can only be created on the same port with the same queue group template name if they have different instance-id values.

The queues defined in the template are created on the queue group. The queue parameters within the template are used as the default queue parameters for each queue in the queue group. The default queue parameters for each queue may be overridden on the queue group with specific queue parameters.

Each queue group supports the application of a scheduler-policy for the purpose of managing the queues within the group into an aggregate SLA. The queues defined within the template may be configured with parent scheduler defining the mapping of a queue to one of the schedulers within the scheduler policy. Egress queue groups also support the **agg-rate** parameter and the queues in the egress template support the port-parent command. Each command is used for configuring egress port virtual scheduling behavior.

Each queue group allows the application of an accounting policy and the ability to enable and disable collecting statistics. The statistics are derived from the queue counters on each queue within the queue group. The accounting policy defines which queue counters are collected and to which accounting file they will be written.

A queue group does not have an administrative shutdown or no shutdown command. A queue group is considered to be always on once created.

When creating a queue group, the system will attempt to allocate queue resources based on the queues defined in the queue group template. If the appropriate queue resources do not currently exist, the queue group will not be created. Ingress port queue groups do not support the shared-queuing or multipoint-shared queuing behavior.

When the queue group is created on a LAG (Link Aggregation Group), it must be created on the primary port member. The primary port member is the port with the lowest port ID based on the slot, MDA position and port number on the MDA. A queue group created on the primary LAG port will be automatically created on all other port members. If a new port is being added to a LAG with an existing queue group, the queue group must first be created on the port prior to adding the port to the LAG. If the LAG queue group has queue overrides, the queue overrides must also be defined on the port queue group prior to adding the port to the LAG.

A port queue group cannot be removed from the port when a forwarding class is currently redirected to the group. All forwarding class redirections must first be removed prior to removing the queue group.

**Default** none

**Parameters** *group-name* — The group-name parameter is required when executing the port queue-group command. The specified group-name must exist as an ingress or egress queue group template depending on the ingress or egress context of the port queue group. Only a single queue group may be created on an ingress port. Multiple queue groups may be created on an egress port.

*instance-id* — Specifies the identification of a specific instance of the queue-group.

**Values** 1 — 40960

**create** — Keyword used to associate the queue group. The **create** keyword requirement can be enabled/

disabled in the **environment>create** context.

## agg-rate

**Syntax** [no] **agg-rate**

**Context** config>port>ethernet>access>egr>qgrp  
 config>port>ethernet>access>egr>vport  
 config>port>ethernet>network>egr>qgrp  
 config>port>sonet-sdh>path>access>egress>vport

**Description** This command is used to control an HQoS aggregate rate limit. It is used in conjunction with the following parameter commands: **rate**, **limit-unused-bandwidth**, and **queue-frame-based-accounting**.

When specified under a VPORT, the agg-rate rate, port-scheduler-policy and scheduler-policy commands are mutually exclusive. Changing between the use of a scheduler policy and the use of an agg-rate/port-scheduler-policy involves removing the existing command and applying the new command.

## rate

**Syntax** **rate** {max | rate}  
**no rate**

**Context** config>port>ethernet>access>egr>qgrp>agg-rate  
 config>port>ethernet>access>egr>vport>agg-rate  
 config>port>ethernet>network>egr>qgrp>agg-rate  
 config>port>sonet-sdh>path>access>egress>vport

**Description** This command defines the enforced aggregate rate for all queues associated with the agg-rate context. A rate must be specified for the agg-rate context to be considered to be active on the context's object (SAP, subscriber, VPORT etc.).

**Parameters** **rate** — Specifies the rate limit for the VPORT.

**Values** **max**, 1— 800000000, max

## limit-unused-bandwidth

**Syntax** [no] **limit-unused-bandwidth**

**Context** config>port>ethernet>access>egr>qgrp>agg-rate  
 config>port>ethernet>access>egr>vport>agg-rate  
 config>port>ethernet>network>egr>qgrp>agg-rate  
 config>port>sonet-sdh>path>access>egress>vport

**Description** This command is used to enable (or disable) aggregate rate overrun protection on the agg-rate context.

## queue-frame-based-accounting

**Syntax** [no] **queue-frame-based-accounting**

**Context** config>port>ethernet>access>egr>qgrp>agg-rate  
config>port>ethernet>access>egr>vport>agg-rate  
config>port>ethernet>network>egr>qgrp>agg-rate  
config>port>sonet-sdh>path>access>egress>vport

**Description** This command is used to enabled (or disable) frame based accounting on all queues associated with the agg-rate context. Only supported on Ethernet ports. Not supported on HSMDA Ethernet ports.

## host-match

**Syntax** **host-match dest** *destination-string* [**create**]  
**no host-match dest** *destination-string*

**Context** config>port>ethernet>access>egr>qgrp

**Description** This command configures host matching for the Ethernet port egress queue-group.  
The no form of the command removes host matching for the Ethernet port egress queue-group.

**Parameters** **dest** *destination-string* — Specify a host match destination string up to 32 characters in length.  
**create** — Keyword used to create the host match. The **create** keyword requirement can be enabled/disabled in the **environment>create** context.

## queue-overrides

**Syntax** **queue-overrides**

**Context** config>port>ethernet>access>egr>qgrp  
config>port>ethernet>access>ing>qgrp  
config>port>ethernet>network>egr>qgrp

**Description** This command enables the context to define optional queue parameter overrides for each queue within the queue group.

## queue

**Syntax** **queue** *queue-id* [*queue-type*] [**create**]  
**no queue** *queue-id*

**Context** config>port>ethernet>access>egr>qgrp>qover  
 config>port>ethernet>access>ing>qgrp>qover  
 config>port>eth>network>egr>qgrp>qover

**Description** This command associates a queue for use in a queue group template. The defined queue-id acts as a repository for the default parameters for the queue. The template queue is created on each queue-group object which is created with the queue group template name. Each queue is identified within the template by a queue-id number. The template ensures that all queue groups created with the template's name will have the same queue-ids providing a uniform structure for the forwarding class redirection commands in the SAP egress QoS policies. The parameters within the template queue will be used as the default settings for each queue in the actual queue group. The queue parameters may be individually changed for each queue in each queue group using per queue overrides.

The **no** form of the command removes the queue-id from the configuration.

**Default** none

## parent

**Syntax** **parent** [[**weight** *weight*] [**cir-weight** *cir-weight*]]  
**no parent**

**Context** config>port>ethernet>access>egr>qgrp>qover>q

**Description** This command, when used in the *queue-overrides* context for a queue group queue, defines an optional **weight** and **cir-weight** for the queue treatment by the parent scheduler that further governs the available bandwidth given the queue aside from the queue PIR setting. When multiple schedulers and/or queues share a child status with the parent scheduler, the weight or level parameters define how this queue contends with the other children for the parent bandwidth.

**Default** none

**Parameters** **weight** *weight* — Weight defines the relative weight of this queue in comparison to other child schedulers and queues while vying for bandwidth on the parent scheduler-name. Any queues or schedulers defined as weighted receive no parental bandwidth until all strict queues and schedulers on the parent have reached their maximum bandwidth or are idle. In this manner, weighted children are considered to be the lowest priority.

**Values** 0 — 100

**Default** 1

**cir-weight** *cir-weight* — Defines the weight the queue will use at the within-cir port priority level. The weight is specified as an integer value from 0 to 100 with 100 being the highest weight. When the cir-weight parameter is set to a value of 0 (the default value), the queue or scheduler does not receive bandwidth during the port schedulers within-cir pass and the cir-level parameter is ignored. If the cir-weight

parameter is 1 or greater, the cir-level parameter comes into play.

**Values** 0 — 100

### adaptation-rule

**Syntax** **adaptation-rule** [**pir** *adaptation-rule*] [**cir** *adaptation-rule*]  
**no adaptation-rule**

**Context** config>port>ethernet>access>egr>qgrp>qover>q  
config>port>ethernet>access>ing>qgrp>qover>q  
config>port>ethernet>network>egr>qover>q

**Description** This command specifies the method used by the system to derive the operational CIR and PIR settings when the queue is provisioned in hardware. For the CIR and PIR parameters individually, the system attempts to find the best operational rate depending on the defined constraint.

The **no** form of the command removes any explicitly defined constraints used to derive the operational CIR and PIR created by the application of the policy. When a specific **adaptation-rule** is removed, the default constraints for **rate** and **cir** apply.

**Default** adaptation-rule pir closest cir closest

**Parameters** **pir** — Defines the constraints enforced when adapting the PIR rate defined within the **queue** *queue-id* **rate** command. The **pir** parameter requires a qualifier that defines the constraint used when deriving the operational PIR for the queue. When the **rate** command is not specified, the default applies.

**cir** — Defines the constraints enforced when adapting the CIR rate defined within the **queue** *queue-id* **rate** command. The **cir** parameter requires a qualifier that defines the constraint used when deriving the operational CIR for the queue. When the **cir** parameter is not specified, the default constraint applies.

*adaptation-rule* — Specifies the adaptation rule to be used while computing the operational CIR or PIR value.

**Values** **max** — The **max** (maximum) option is mutually exclusive with the **min** and **closest** options. When **max** is defined, the operational PIR for the queue will be equal to or less than the administrative rate specified using the **rate** command.

**min** — The **min** (minimum) option is mutually exclusive with the **max** and **closest** options. When **min** is defined, the operational PIR for the queue will be equal to or greater than the administrative rate specified using the **rate** command.

**closest** — The **closest** parameter is mutually exclusive with the **min** and **max** parameter. When **closest** is defined, the operational PIR for the queue will be the rate closest to the rate specified using the **rate** command.

## burst-limit

|                    |                                                                                                                                                                                                                                                                                                                                                                                                                                                                                                                                                                                                                                                                                                                                                                                                                                                                                                                                                                                                                                                                                                                                                                                                                                                                                                                                                                |
|--------------------|----------------------------------------------------------------------------------------------------------------------------------------------------------------------------------------------------------------------------------------------------------------------------------------------------------------------------------------------------------------------------------------------------------------------------------------------------------------------------------------------------------------------------------------------------------------------------------------------------------------------------------------------------------------------------------------------------------------------------------------------------------------------------------------------------------------------------------------------------------------------------------------------------------------------------------------------------------------------------------------------------------------------------------------------------------------------------------------------------------------------------------------------------------------------------------------------------------------------------------------------------------------------------------------------------------------------------------------------------------------|
| <b>Syntax</b>      | <b>burst-limit {default   size [byte   kilobyte]}</b><br><b>no burst-limit</b>                                                                                                                                                                                                                                                                                                                                                                                                                                                                                                                                                                                                                                                                                                                                                                                                                                                                                                                                                                                                                                                                                                                                                                                                                                                                                 |
| <b>Context</b>     | config>port>ethernet>access>egr>qgrp>qover>q<br>config>port>ethernet>access>ing>qgrp>qover>q<br>config>port>ethernet>network>egr>qover>q                                                                                                                                                                                                                                                                                                                                                                                                                                                                                                                                                                                                                                                                                                                                                                                                                                                                                                                                                                                                                                                                                                                                                                                                                       |
| <b>Description</b> | <p>The <code>queue burst-limit</code> command is used to define an explicit shaping burst size for a queue. The configured size defines the shaping leaky bucket threshold level that indicates the maximum burst over the queue's shaping rate.</p> <p>The <code>burst-limit</code> command is supported under the sap-ingress and sap-egress QoS policy queues. The command is also supported under the ingress and egress queue-group-templates queues.</p> <p>The <b>no</b> form of this command is used to restore the default burst limit to the specified queue. This is equivalent to specifying <code>burst-limit default</code> within the QoS policies or queue group templates. When specified within a <code>queue-override</code> queue context, any current burst limit override for the queue will be removed and the queue's burst limit will be controlled by its defining policy or template.</p>                                                                                                                                                                                                                                                                                                                                                                                                                                           |
| <b>Parameters</b>  | <p><b>default</b> — The default parameter is mutually exclusive to specifying an explicit size value. When <code>burst-limit default</code> is executed, the queue is returned to the system default value.</p> <p><i>size</i> — When a numeric value is specified (<i>size</i>), the system interprets the value as an explicit burst limit size. The value is expressed as an integer and by default is interpreted as the burst limit in Kilobytes. If the value is intended to be interpreted in bytes, the byte qualifier must be added following <i>size</i>.</p> <p><b>Values</b> 1 to 14,000 (14,000 or 14,000,000 depending on bytes or kilobytes)</p> <p><b>Default</b> No default for <i>size</i>, use the default keyword to specify default burst limit</p> <p><b>byte</b> — The <b>bytes</b> qualifier is used to specify that the value given for <i>size</i> must be interpreted as the burst limit in bytes. The byte qualifier is optional and mutually exclusive with the kilobytes qualifier.</p> <p><b>kilobyte</b> — The <b>kilobyte</b> qualifier is used to specify that the value given for <i>size</i> must be interpreted as the burst limit in Kilobytes. The kilobyte qualifier is optional and mutually exclusive with the bytes qualifier. If neither bytes nor kilobytes is specified, the default qualifier is kilobytes.</p> |

## cbs

|                    |                                                                                                                                                                                                                                                                                                                                                                                                                                                                                   |
|--------------------|-----------------------------------------------------------------------------------------------------------------------------------------------------------------------------------------------------------------------------------------------------------------------------------------------------------------------------------------------------------------------------------------------------------------------------------------------------------------------------------|
| <b>Syntax</b>      | <b>cbs <i>size-in-kbytes</i></b><br><b>no cbs</b>                                                                                                                                                                                                                                                                                                                                                                                                                                 |
| <b>Context</b>     | config>port>ethernet>access>egr>qgrp>qover>q<br>config>port>ethernet>access>ing>qgrp>qover>q<br>config>port>ethernet>network>egr>qover>q                                                                                                                                                                                                                                                                                                                                          |
| <b>Description</b> | <p>The <code>cbs</code> command is used to define the default committed buffer size for the template queue. Overall, the <code>cbs</code> command follows the same behavior and provisioning characteristics as the <code>cbs</code> command in the SAP ingress QoS policy. The exception is the addition of the <code>cbs-value</code> qualifier keywords bytes or kilobytes.</p> <p>The <b>no</b> form of this command restores the default CBS size to the template queue.</p> |

## Ethernet Port Commands

**Default** default

**Parameters** *size-in-kbytes* — The size parameter is an integer expression of the number of kilobytes reserved for the queue. If a value of 10KBytes is desired, enter the value 10. A value of 0 specifies that no reserved buffers are required by the queue (a minimal reserved size can still be applied for scheduling purposes).

**Values** 0 — 131072 or default

## high-prio-only

**Syntax** **high-prio-only** *percent*  
**no high-prio-only**

**Context** config>port>ethernet>access>egr>qgrp>qover>q  
config>port>ethernet>access>ing>qgrp>qover>q  
config>port>ethernet>network>egr>qover>q

**Description** The **high-prio-only** command specifies the percentage of buffer space for the queue, used exclusively by high priority packets. The specified value overrides the default value for the context.

The priority of a packet can only be set in the SAP ingress QoS policy and is only applicable on the ingress queues for a SAP. The **high-prio-only** parameter is used to override the default value derived from the **network-queue** command.

The **no** form of this command restores the default high priority reserved size.

**Parameters** *percent* — The percentage reserved for high priority traffic on the queue. If a value of 10KBytes is desired, enter the value 10.

**Values** 0 — 100, default

## mbs

**Syntax** **mbs** *size-in-kbytes*  
**no mbs**

**Context** config>port>ethernet>access>egr>qgrp>qover>q  
config>port>ethernet>access>ing>qgrp>qover>q  
config>port>ethernet>network>egr>qover>q

**Description** The Maximum Burst Size (MBS) command specifies the default maximum buffer size for the template queue. The value is given in kilobytes.

The MBS value is used by a queue to determine whether it has exhausted all of its buffers while enqueueing packets. Once the queue has exceeded the amount of buffers allowed by MBS, all packets are discarded until packets have been drained from the queue.

The sap-ingress context for mbs provides a mechanism for overriding the default maximum size for the queue.

The sum of the MBS for all queues on an ingress access port can oversubscribe the total amount of buffering available. When congestion occurs and buffers become scarce, access to buffers is controlled by the RED

slope a packet is associated with. A queue that has not exceeded its MBS size is not guaranteed that a buffer will be available when needed or that the packets RED slope will not force the discard of the packet. Setting proper CBS parameters and controlling CBS oversubscription is one major safeguard to queue starvation (when a queue does not receive its fair share of buffers). Another is properly setting the RED slope parameters for the needs of services on this port or channel.

If the CBS value is larger than the MBS value, an error will occur, preventing the MBS change.

The **no** form of this command returns the MBS size assigned to the queue to the value.

**Default** default

**Parameters** *size-in-kbytes* — The size parameter is an integer expression of the maximum number of kilobytes of buffering allowed for the queue. For a value of 100 kbps, enter the value 100. A value of 0 causes the queue to discard all packets.

**Values** 0 — 131072 or default

## rate

**Syntax** **rate** *pir-rate* [*cir cir-rate*]  
**no rate**

**Context** config>port>ethernet>access>egr>qgrp>qover>q  
config>port>ethernet>access>ing>qgrp>qover>q  
config>port>ethernet>network>egr>qover>q

**Description** This command specifies the administrative Peak Information Rate (PIR) and the administrative Committed Information Rate (CIR) parameters for the queue. The PIR defines the maximum rate that the queue can transmit packets out an egress interface (for SAP egress queues). Defining a PIR does not necessarily guarantee that the queue can transmit at the intended rate. The actual rate sustained by the queue can be limited by oversubscription factors or available egress bandwidth.

The CIR defines the rate at which the system prioritizes the queue over other queues competing for the same bandwidth. In-profile packets are preferentially queued by the system at egress and at subsequent next hop nodes where the packet can traverse. To be properly handled as in- or out-of-profile throughout the network, the packets must be marked accordingly for profiling at each hop.

The CIR can be used by the queue's parent commands *cir-level* and *cir-weight* parameters to define the amount of bandwidth considered to be committed for the child queue during bandwidth allocation by the parent scheduler.

The **rate** command can be executed at anytime, altering the PIR and CIR rates for all queues created through the association of the SAP egress QoS policy with the *queue-id*.

The **no** form of the command returns all queues created with the *queue-id* by association with the QoS policy to the default PIR and CIR parameters (**max**, 0).

**Default** **rate max cir 0** — The **max** default specifies the amount of bandwidth in kilobits per second (thousand bits per second). The **max** value is mutually exclusive to the **pir-rate** value.

**Parameters** *pir-rate* — Defines the administrative PIR rate, in kilobits, for the queue. When the **rate** command is executed, a valid PIR setting must be explicitly defined. When the **rate** command has not been executed, the default PIR of **max** is assumed.

## Ethernet Port Commands

Fractional values are not allowed and must be given as a positive integer.

The actual PIR rate is dependent on the queue's **adaptation-rule** parameters and the actual hardware where the queue is provisioned.

**Values** 1 — 100000000, **max**

**Default** max

*cir-rate* — The **cir** parameter overrides the default administrative CIR used by the queue. When the **rate** command is executed, a CIR setting is optional. When the **rate** command has not been executed or the **cir** parameter is not explicitly specified, the default CIR (0) is assumed.

Fractional values are not allowed and must be given as a positive integer.

**Values** 0 — 100000000, **max**

**Default** 0

## scheduler-policy

**Syntax** **scheduler-policy** *scheduler-policy-name*  
**no scheduler-policy**

**Context** config>port>ethernet>access>egr>qgrp  
config>port>ethernet>access>ing>qgrp  
config>port>ethernet>network>egr>qgrp

**Description** This command associates a virtual scheduler policy with a port queue group. Scheduler policies are defined in the **config>qos>scheduler-policy** *scheduler-policy-name* context.

The **no** form of this command removes the configured ingress or egress scheduler policy from the queue-group.

**Parameters** *scheduler-policy-name* — The *scheduler-policy-name* parameter applies an existing scheduler policy that was created in the **config>qos>scheduler-policy** *scheduler-policy-name* context to create the hierarchy of ingress or egress virtual schedulers.

## exp-secondary-shaper

**Syntax** **exp-secondary-shaper** {**default** | *secondary-shaper-name*} **create**  
**no exp-secondary-shaper** *secondary-shaper-name*

**Context** config>port>ethernet>egress

**Description** This command configures the Ethernet egress expanded secondary shaper on this port.

**Parameters** *secondary-shaper-name* — Specifies the secondary shaper name to apply to this port.

**default** — Specifies the default secondary shaper to apply to this port.

**create** — Creates a new secondary shaper for this port.

## rate

**Syntax** **rate** {**max** | **kilobits-per-second**}  
**no rate**

**Context** config>port>ethernet>egress>exp-secondary-shaper

**Description** This command is used to configure the shaper's metering and optional profiling rates. The metering rate is used by the system to configure the shaper's PIR leaky bucket's decrement rate. The decrement function empties the bucket while packets applied to the bucket attempt to fill it based on the each packets size. If the bucket fills faster than how much is decremented per packet, the bucket's depth eventually reaches its violate (PIR) threshold.

The **no** form of this command is used to restore the default metering and profiling rate to a policer.

**Parameters** {**max** | *kilobits-per-second*} — Specifying the keyword **max** or an explicit *kilobits-per-second* parameter directly following the rate command is required and identifies the policer's metering rate for the PIR leaky bucket. When the shaper is first created, the metering rate defaults to max. The *kilobits-per-second* value must be expressed as an integer and defines the rate in kilobits-per-second. The integer value is multiplied by 1,000 to derive the actual rate in bits-per-second.

**Values** 1—10000000 kbps

## class

**Syntax** **class** *class-number* **rate** {*kilobits-per-second* | **max**} [**monitor-threshold** *size-in-kilobytes*]  
**no class**

**Context** config>port>ethernet>egress>exp-secondary-shaper

**Description** This command assigns the low burst maximum class to associate with the Ethernet egress expanded secondary shaper.

The **no** form of the command returns the class id for the Ethernet egress expanded secondary shaper to the default value.

**Parameters** *class-id* — Specifies the class identifier of the low burst max class for the shaper.

**Values** 1— 32

**rate** {*kilobits-per-second* / **max**} — Specifies the rate limit for the secondary shaper.

**Values** **max**, 1— 10000000

**monitor-threshold** *size-in-kilobytes* — Specifies the monitor threshold for the secondary shaper.

**Values** 0— 8190

## low-burst-max-class

|                    |                                                                                                                                                                                                                                            |
|--------------------|--------------------------------------------------------------------------------------------------------------------------------------------------------------------------------------------------------------------------------------------|
| <b>Syntax</b>      | <b>low-burst-max-class</b> <i>class</i><br><b>no low-burst-max-class</b>                                                                                                                                                                   |
| <b>Context</b>     | config>port>ethernet>egress>exp-secondary-shaper                                                                                                                                                                                           |
| <b>Description</b> | This command specifies the class to associate with the Ethernet egress expanded secondary shaper. The <b>no</b> form of the command returns the class number value for the Ethernet egress expanded secondary shaper to the default value. |
| <b>Parameters</b>  | <i>class</i> — Specifies the class number of the class for the secondary shaper.<br><b>Values</b> 1— 8                                                                                                                                     |

## vport

|                    |                                                                                                                                                                                                                                                                                                                                                                                                                                                                                                                                                                                                                                                                                                                                                                                                                                                                                                                                                                                                                                                                                                                                                                                                                                                                                                                                                                                                                                                  |
|--------------------|--------------------------------------------------------------------------------------------------------------------------------------------------------------------------------------------------------------------------------------------------------------------------------------------------------------------------------------------------------------------------------------------------------------------------------------------------------------------------------------------------------------------------------------------------------------------------------------------------------------------------------------------------------------------------------------------------------------------------------------------------------------------------------------------------------------------------------------------------------------------------------------------------------------------------------------------------------------------------------------------------------------------------------------------------------------------------------------------------------------------------------------------------------------------------------------------------------------------------------------------------------------------------------------------------------------------------------------------------------------------------------------------------------------------------------------------------|
| <b>Syntax</b>      | <b>vport</b> <i>name</i> [create]<br><b>no vport</b> <i>name</i>                                                                                                                                                                                                                                                                                                                                                                                                                                                                                                                                                                                                                                                                                                                                                                                                                                                                                                                                                                                                                                                                                                                                                                                                                                                                                                                                                                                 |
| <b>Context</b>     | config>port>ethernet>access>egress<br>config>port>sonet-sdh>path>access>egress                                                                                                                                                                                                                                                                                                                                                                                                                                                                                                                                                                                                                                                                                                                                                                                                                                                                                                                                                                                                                                                                                                                                                                                                                                                                                                                                                                   |
| <b>Description</b> | <p>This command configures a scheduling node, referred to as virtual port, within the context of an egress Ethernet port. The vport scheduler operates either like a port scheduler with the difference that multiple vport objects can be configured on the egress context of an Ethernet port, or it can be an aggregate rate when an egress port-scheduler policy is applied to the port.</p> <p>The vport is always configured at the port level even when a port is a member of a LAG.</p> <p>When a a port scheduler policy is applied to a vport the following command is used:</p> <pre><b>configure&gt;port&gt;ethernet&gt;access&gt;egress&gt;vport&gt;port-scheduler-policy</b> <i>port-scheduler-policy-name</i></pre> <p>The CLI will not allow the user to apply a port scheduler policy to a vport if one has been applied to the port. Conversely, the CLI will not allow the user to apply a port scheduler policy to the egress of an Ethernet port if one has been applied to any vport defined on the access egress context of this port. The <b>agg-rate</b>, along with an egress port-scheduler, can be used to ensure that a given vport does not oversubscribe the port's rate.</p> <p>SAP and subscriber host queues can be port-parented to a vport scheduler in a similar way they port-parent to a port scheduler or can be port-parented directly to the egress port-scheduler if the <b>agg-rate</b> is used.</p> |
| <b>Parameters</b>  | <i>name</i> — Specifies the name of the vport scheduling node and can be up to 32 ASCII characters in length. This does not need to be unique within the system but is unique within the port or a LAG.                                                                                                                                                                                                                                                                                                                                                                                                                                                                                                                                                                                                                                                                                                                                                                                                                                                                                                                                                                                                                                                                                                                                                                                                                                          |

## agg-rate

**Syntax** [no] **agg-rate**

**Context** config>port>sonet-sdh>path>access>egress>vport  
 configure>port>ethernet>access>egress>vport

**Description** This command configures an aggregate rate for the vport. The **agg-rate** rate, **port-scheduler-policy** and **scheduler-policy** commands are mutually exclusive. Changing between the use of a scheduler policy and the use of an **agg-rate/port-scheduler-policy** involves removing the existing command and applying the new command.

**Parameters** *agg-rate* — Specifies the rate limit for the vport.

**Values** 1 — 800000000, max

## egress-rate-modify

**Syntax** [no] **egress-rate-modify**

**Context** configure>port>ethernet>access>egress>vport  
 configure>port>sonet-sdh>path>access>egress>vport

**Description** This command is used to apply HQoS Adjustment to a vport. HQoS Adjustment refers to the dynamic adjustment of the rate limit at a QoS enforcement point within 7x50 when the multicast traffic stream is disjointed from the unicast traffic stream. This QoS enforcement point within 7x50 represents the physical point further down in the access part of the network where the two streams join each other and potentially can cause congestion.

An example would be a PON port which is shared amongst subscriber's multicast traffic (single copy of each channel) and subscriber's unicast traffic. The bandwidth control point for this PON port resides in the upstream 7x50 BNG node in the form of a Vport. In case that the multicast delivery method in the 7x50 BNG utilizes redirection, the multicast traffic in the 7x50 BNG will flow outside of the subscriber or the Vport context and thus will bypass any bandwidth enforcement in 7x50. To correct this, a Vport bandwidth adjustment is necessary in 7x50 that will account for the multicast bandwidth consumption that is bypassing Vport in 7x50 but is present in the PON port whose bandwidth is controlled by Vport.

An estimate of the multicast bandwidth consumption on the PON port can be made at the Vport level based on the IGMP messages sourced from the subscribers behind the PON port. This process is called HQoS Adjustment.

A multicast channel bandwidth is subtracted from or added to the Vport rate limit according to the received IGMP Join/Leave messages and the channel bandwidth definition policy associated with the Vport (indirectly through a group-interface). Since the multicast traffic on the PON port is shared amongst subscribers behind this PON port, only the first IGMP Join or the last IGMP Leave per multicast channel is tracked for the purpose of the Vport bandwidth modification.

The Vport rate that will be affected by this functionality depends on the configuration:

- In case the **agg-rate** within the Vport is configured, its value will be modified based on the IGMP activity associated with the subscriber under this Vport.

## Ethernet Port Commands

- In case the port-scheduler-policy within the Vport is referenced, the max-rate defined in the corresponding port-scheduler-policy will be modified based on the IGMP activity associated with the subscriber under this Vport.

The channel bandwidth definition policy is defined in the mcac policy in the **configure>router>mcac>policy** context. The policy is applied under the group-interface or in case of redirection under the redirected-interface.

The rates in effect can be displayed with the following two commands:

**show port 1/1/5 vport** *name*

**qos scheduler-hierarchy** port *port-id* vport *vport-name*

The configuration of a scheduler policy under a VPORT, which is only applicable to Ethernet interfaces, is mutually exclusive with the configuration of the **egress-rate-modify** parameter.

**Context** HQoS Adjustment for Vport is disabled.

## host-match

**Syntax** **host-match dest** *description-string* [**create**]  
**no host-match dest** *destination-string*

**Context** config>port>sonet-sdh>path>access>egress>vportconfig>port>ethernet>access>egress>vport

**Description** This command specifies the destination and organization strings to be used for matching subscriber hosts with this vport.

The parent vport of a subscriber host queue, which has the port-parent option enabled, is determined by matching the destination string **dest** string associated with the subscriber and the organization string org string associated with the subscriber host with the strings defined under a vport on the port associated with the subscriber.

If a given subscriber host queue does not have the port-parent option enabled, it will be foster-parented to the vport used by this subscriber and which is based on matching the dest string and org string. If the subscriber could not be matched with a vport on the egress port, the host queue will not be bandwidth controlled and will compete for bandwidth directly based on its own PIR and CIR parameters.

By default, a subscriber host queue with the port-parent option enabled is scheduled within the context of the port's port scheduler policy.

**Parameters** *description-string* — The destination character string. Allowed values are any string up to 80 characters long composed of printable, 7-bit ASCII characters. If the string contains special characters (#, \$, spaces, etc.), the entire string must be enclosed within double quotes.

## port-scheduler-policy

|                    |                                                                                                                                                                                                                                                                                                                                                                                                                                                                                                                                                                                                                                                                                                                                                                                                                                                                                                                                                                                                                                                                                                                                                                                                                                                                                                                                                                                                                                                                     |
|--------------------|---------------------------------------------------------------------------------------------------------------------------------------------------------------------------------------------------------------------------------------------------------------------------------------------------------------------------------------------------------------------------------------------------------------------------------------------------------------------------------------------------------------------------------------------------------------------------------------------------------------------------------------------------------------------------------------------------------------------------------------------------------------------------------------------------------------------------------------------------------------------------------------------------------------------------------------------------------------------------------------------------------------------------------------------------------------------------------------------------------------------------------------------------------------------------------------------------------------------------------------------------------------------------------------------------------------------------------------------------------------------------------------------------------------------------------------------------------------------|
| <b>Syntax</b>      | <b>port-scheduler-policy</b> <i>port-scheduler-policy-name</i><br><b>no port-scheduler-policy</b>                                                                                                                                                                                                                                                                                                                                                                                                                                                                                                                                                                                                                                                                                                                                                                                                                                                                                                                                                                                                                                                                                                                                                                                                                                                                                                                                                                   |
| <b>Context</b>     | config>port>sonet-sdh>path>access>egress>vport<br>config>port>ethernet>access>egress>vport                                                                                                                                                                                                                                                                                                                                                                                                                                                                                                                                                                                                                                                                                                                                                                                                                                                                                                                                                                                                                                                                                                                                                                                                                                                                                                                                                                          |
| <b>Description</b> | <p>This command specifies the destination and organization strings to be used for matching subscriber hosts with this vport.</p> <p>The parent vport of a subscriber host queue, which has the port-parent option enabled, is determined by matching the destination string dest string associated with the subscriber and the organization string org string associated with the subscriber host with the strings defined under a vport on the port associated with the subscriber.</p> <p>If a given subscriber host queue does not have the port-parent option enabled, it will be foster-parented to the vport used by this subscriber and which is based on matching the dest string and org string. If the subscriber could not be matched with a vport on the egress port, the host queue will not be bandwidth controlled and will compete for bandwidth directly based on its own PIR and CIR parameters.</p> <p>By default, a subscriber host queue with the port-parent option enabled is scheduled within the context of the port? port scheduler policy.</p> <p>The no form of the command removes the port-scheduler-policy-name from the configuration. The <b>agg-rate rate</b>, <b>port-scheduler-policy</b> and <b>scheduler-policy</b> commands are mutually exclusive. Changing between the use of a scheduler policy and the use of an agg-rate/port-scheduler-policy involves removing the existing command and applying the new command.</p> |
| <b>Parameters</b>  | <i>port-scheduler-policy-name</i> — Specifies an existing port-scheduler-policy configured in the config>qos context.                                                                                                                                                                                                                                                                                                                                                                                                                                                                                                                                                                                                                                                                                                                                                                                                                                                                                                                                                                                                                                                                                                                                                                                                                                                                                                                                               |

## scheduler-policy

|                    |                                                                                                                                                                                                                                                                                                                                                                                                                                                                                                                                                                                                                                                                                                                                                                                                                                                                                                                                                                                                                                                                                                                                                          |
|--------------------|----------------------------------------------------------------------------------------------------------------------------------------------------------------------------------------------------------------------------------------------------------------------------------------------------------------------------------------------------------------------------------------------------------------------------------------------------------------------------------------------------------------------------------------------------------------------------------------------------------------------------------------------------------------------------------------------------------------------------------------------------------------------------------------------------------------------------------------------------------------------------------------------------------------------------------------------------------------------------------------------------------------------------------------------------------------------------------------------------------------------------------------------------------|
| <b>Syntax</b>      | <b>scheduler-policy</b> <i>scheduler-policy-name</i><br><b>no scheduler-policy</b>                                                                                                                                                                                                                                                                                                                                                                                                                                                                                                                                                                                                                                                                                                                                                                                                                                                                                                                                                                                                                                                                       |
| <b>Context</b>     | config>port>ethernet>access>egress>vport                                                                                                                                                                                                                                                                                                                                                                                                                                                                                                                                                                                                                                                                                                                                                                                                                                                                                                                                                                                                                                                                                                                 |
| <b>Description</b> | <p>This command specifies a scheduler policy to associate to the VPORT. Scheduler policies are configured in the configure&gt;qos&gt;scheduler&gt;policy context. Each scheduler policy is divided up into groups of schedulers based on the tier each scheduler is created under. A tier is used to give structure to the schedulers within a policy and define rules for parent scheduler associations. The policy defines the hierarchy and operating parameters for virtual schedulers.</p> <p>The <b>no</b> form of this command removes the configured egress scheduler policy from the VPORT.</p> <p>The <b>agg-rate rate</b>, <b>port-scheduler-policy</b>, and <b>scheduler-policy</b> commands are mutually exclusive. Changing between the use of a scheduler policy and the use of an agg-rate/port-scheduler-policy involves removing the existing command and applying the new command. Applying a <b>scheduler-policy</b> to a VPORT is only applicable to Ethernet interfaces.</p> <p>The configuration of a scheduler policy under a VPORT is mutually exclusive with the configuration of the <b>egress-rate-modify</b> parameter.</p> |

## Ethernet Port Commands

**Default** no scheduler-policy

**Parameters** *scheduler-policy-name* — Specifies an existing scheduler policy name that was created in the `config>qos>scheduler-policy scheduler-policy-name` context to create the hierarchy of egress virtual schedulers.

## autonegotiate

**Syntax** **autonegotiate [limited]**  
**no autonegotiate**

**Context** config>port>ethernet

**Description** This command enables speed and duplex autonegotiation on Fast Ethernet ports and enables far-end fault indicator support on gigabit ports.

There are three possible settings for autonegotiation:

- “on” or enabled with full port capabilities advertised
- “off” or disabled where there are no autonegotiation advertisements
- “limited” where a single speed/duplex is advertised.

When autonegotiation is enabled on a port, the link attempts to automatically negotiate the link speed and duplex parameters. If autonegotiation is enabled, the configured duplex and speed parameters are ignored.

When autonegotiation is disabled on a port, the port does not attempt to autonegotiate and will only operate at the **speed** and **duplex** settings configured for the port. Note that disabling autonegotiation on gigabit ports is not allowed as the IEEE 802.3 specification for gigabit Ethernet requires autonegotiation be enabled for far end fault indication.

If the **autonegotiate limited** keyword option is specified the port will autonegotiate but will only advertise a specific speed and duplex. The speed and duplex advertised are the **speed** and **duplex** settings configured for the port. One use for limited mode is for multispeed gigabit ports to force gigabit operation while keeping autonegotiation enabled for compliance with IEEE 801.3.

7950 SR requires that autonegotiation be disabled or limited for ports in a Link Aggregation Group to guarantee a specific port speed.

The **no** form of this command disables autonegotiation on this port.

**Default** autonegotiate

**Parameters** **limited** — The Ethernet interface will automatically negotiate link parameters with the far end, but will only advertise the speed and duplex mode specified by the Ethernet **speed** and **duplex** commands.

## dot1q-etype

|                    |                                                                                                                                                                                                                                                  |
|--------------------|--------------------------------------------------------------------------------------------------------------------------------------------------------------------------------------------------------------------------------------------------|
| <b>Syntax</b>      | <b>dot1q-etype 0x0600..0xffff</b><br><b>no dot1q-etype</b>                                                                                                                                                                                       |
| <b>Context</b>     | config>port>ethernet                                                                                                                                                                                                                             |
| <b>Description</b> | This command specifies the Ethertype expected when the port's encapsulation type is dot1q. Dot1q encapsulation is supported only on Ethernet interfaces.<br><br>The <b>no</b> form of this command reverts the dot1q-etype value to the default. |
| <b>Parameters</b>  | <i>0x0600..0xffff</i> — Specifies the Ethertype to expect.<br><br><b>Default</b> If the encap-type is dot1p, then the default is 0x8100.<br>If the encap-type is qinq, then the default is 0x8100.                                               |

## duplex

|                    |                                                                                                                                                                                                                                                                               |
|--------------------|-------------------------------------------------------------------------------------------------------------------------------------------------------------------------------------------------------------------------------------------------------------------------------|
| <b>Syntax</b>      | <b>duplex {full   half}</b>                                                                                                                                                                                                                                                   |
| <b>Context</b>     | config>port>ethernet                                                                                                                                                                                                                                                          |
| <b>Description</b> | This command configures the duplex of a Fast Ethernet port when autonegotiation is disabled.<br><br>This configuration command allows for the configuration of the duplex mode of a Fast Ethernet port. If the port is configured to autonegotiate this parameter is ignored. |
| <b>Default</b>     | <b>full</b>                                                                                                                                                                                                                                                                   |
| <b>Parameters</b>  | <b>full</b> — Sets the link to full duplex mode.<br><b>half</b> — Sets the link to half duplex mode.                                                                                                                                                                          |

## efm-oam

|                    |                                             |
|--------------------|---------------------------------------------|
| <b>Syntax</b>      | <b>efm-oam</b>                              |
| <b>Context</b>     | config>port>ethernet                        |
| <b>Description</b> | This command configures EFM-OAM attributes. |

## accept-remote-loopback

|                    |                                                                         |
|--------------------|-------------------------------------------------------------------------|
| <b>Syntax</b>      | <b>[no] accept-remote-loopback</b>                                      |
| <b>Context</b>     | config>port>ethernet>efm-oam                                            |
| <b>Description</b> | This command enables reactions to loopback control OAM PDUs from peers. |

## Ethernet Port Commands

The **no** form of this command disables reactions to loopback control OAM PDUs.

**Default** no accept-remote-loopback

### grace-tx-enable

**Syntax** [no] grace-tx-enable

**Context** config>system>ethernet>efm-oam  
config>port>ethernet>efm-oam

**Description** Enables the sending of grace for all the enabled EFM-OAM sessions on the node. Disabled by default at the system level and enabled by default at the port level. The combination of the system level and port level configuration will determine if the grace is enabled on the individual ports. Both the system level and the port level must be enabled in order to support grace on a specific port. If either is disabled grace is not enabled on those ports. Enabling grace during an active ISSU or soft reset will not be in for that event.

**Default** config>system>ethernet>efm-oam [no] grace-tx-enable  
config>port>ethernet>efm-oam grace-tx-enable

## hold-time

|                    |                                                                                                                                                                                                                                                                                                                                                                                                                                                                                                                                                                                                                                                                                                                                                                                                                                                              |
|--------------------|--------------------------------------------------------------------------------------------------------------------------------------------------------------------------------------------------------------------------------------------------------------------------------------------------------------------------------------------------------------------------------------------------------------------------------------------------------------------------------------------------------------------------------------------------------------------------------------------------------------------------------------------------------------------------------------------------------------------------------------------------------------------------------------------------------------------------------------------------------------|
| <b>Syntax</b>      | <b>hold-time</b> <i>time-value</i><br><b>no hold-time</b>                                                                                                                                                                                                                                                                                                                                                                                                                                                                                                                                                                                                                                                                                                                                                                                                    |
| <b>Context</b>     | config>port>ethernet>efm-oam                                                                                                                                                                                                                                                                                                                                                                                                                                                                                                                                                                                                                                                                                                                                                                                                                                 |
| <b>Description</b> | This command configures efm-oam operational transition dampening timers which reduce the number of efm-oam state transitions reported to upper layers.                                                                                                                                                                                                                                                                                                                                                                                                                                                                                                                                                                                                                                                                                                       |
| <b>Default</b>     | 0                                                                                                                                                                                                                                                                                                                                                                                                                                                                                                                                                                                                                                                                                                                                                                                                                                                            |
| <b>Parameters</b>  | <i>time-value</i> — Indicates the number of seconds that the efm-oam protocol will wait before going back to the operational state after leaving the operational state. Note that the hold-time does not apply if efm-oam moved from operational to link-fault.<br><br>A hold-time value of zero indicates that there should be no delay in transitioning to the operational state. A non-zero value will cause the efm-oam protocol to attempt to negotiate with a peer if possible, but it will remain in the send-local-remote-ok state until the hold time has expired if negotiation is successful.<br><br>If efm-oam is administratively shutdown while it was in the operational state and then re-enabled when a non-zero hold time is configured, efm-oam will attempt transition to the operational state immediately.<br><br><b>Values</b> 0 — 50 |

## ignore-efm-state

|                    |                                                                                                                                                                                                                                                                                                                                                                             |
|--------------------|-----------------------------------------------------------------------------------------------------------------------------------------------------------------------------------------------------------------------------------------------------------------------------------------------------------------------------------------------------------------------------|
| <b>Syntax</b>      | <b>[no] ignore-efm-state</b>                                                                                                                                                                                                                                                                                                                                                |
| <b>Context</b>     | config>port>ethernet>efm-oam>                                                                                                                                                                                                                                                                                                                                               |
| <b>Description</b> | When the <b>ignore-efm-state</b> command is configured, ANY failure in the protocol state machine (discovery, configuration, timeout, loops, etc.) does not impact the state of the port. There is only be a protocol warning message on the port. If this optional command is not configured, the port state is affected by any existing EFM-OAM protocol fault condition. |
| <b>Default</b>     | <b>no ignore-efm-state</b>                                                                                                                                                                                                                                                                                                                                                  |

## mode

|                    |                                                                                                                                                                                                                                                                                                                                                       |
|--------------------|-------------------------------------------------------------------------------------------------------------------------------------------------------------------------------------------------------------------------------------------------------------------------------------------------------------------------------------------------------|
| <b>Syntax</b>      | <b>mode</b> { <b>active</b>   <b>passive</b> }                                                                                                                                                                                                                                                                                                        |
| <b>Context</b>     | config>port>ethernet>efm-oam                                                                                                                                                                                                                                                                                                                          |
| <b>Description</b> | This command configures the mode of OAM operation for this Ethernet port. These two modes differ in that active mode causes the port to continually send out efm-oam info PDUs while passive mode waits for the peer to initiate the negotiation process. A passive mode port cannot initiate monitoring activities (such as loopback) with the peer. |
| <b>Default</b>     | active                                                                                                                                                                                                                                                                                                                                                |

## Ethernet Port Commands

**Parameters**    **active** — Provides capability to initiate negotiation and monitoring activities.  
                  **passive** — Relies on peer to initiate negotiation and monitoring activities.

### transmit-interval

**Syntax**    **[no] transmit-interval** *interval* [**multiplier** *multiplier*]

**Context**    config>port>ethernet>efm-oam

**Description**    This command configures the transmit interval of OAM PDUs.

**Default**    transmit-interval 10 multiplier 5

**Parameters**    *interval* — Specifies the transmit interval.  
                  **Values**    1 — 600 (in 100 milliseconds)

**multiplier** *multiplier* — Specifies the multiplier for transmit-interval to set local link down timer.  
                  **Values**    2 — 5

### tunneling

**Syntax**    **[no] tunneling**

**Context**    config>port>ethernet>efm-oam

**Description**    This command enables EFM OAM PDU tunneling. Enabling tunneling will allow a port mode Epipe SAP to pass OAM frames through the pipe to the far end.  
                  The **no** form of the command disables tunneling.

**Default**    no tunneling

### egress-rate

**Syntax**    **egress-rate** *sub-rate*  
                  **no egress-rate**

**Context**    config>port>ethernet

**Description**    This command configures the rate of traffic leaving the network.  
                  The **no** form of this command returns the value to the default.

**Default**    no egress-rate

**Parameters**    *sub-rate* — The egress rate in Kbps.  
                  **Values**    1 — 10000000

## encap-type

|                    |                                                                                                                                                                                                                                                                                                                      |
|--------------------|----------------------------------------------------------------------------------------------------------------------------------------------------------------------------------------------------------------------------------------------------------------------------------------------------------------------|
| <b>Syntax</b>      | <b>encap-type</b> {dot1q   null   qinq}<br><b>no encap-type</b>                                                                                                                                                                                                                                                      |
| <b>Context</b>     | config>port>ethernet                                                                                                                                                                                                                                                                                                 |
| <b>Description</b> | This command configures the encapsulation method used to distinguish customer traffic on an Ethernet access port, or different VLANs on a network port.<br>The <b>no</b> form of this command restores the default.                                                                                                  |
| <b>Default</b>     | null                                                                                                                                                                                                                                                                                                                 |
| <b>Parameters</b>  | <b>dot1q</b> — Ingress frames carry 802.1Q tags where each tag signifies a different service.<br><b>null</b> — Ingress frames will not use any tags to delineate a service. As a result, only one service can be configured on a port with a null encapsulation type.<br><b>qinq</b> — Specifies QinQ encapsulation. |

## hold-time

|                    |                                                                                                                                                                                                                                                                                                                                                                                                                                                                                                                                                                                                                                                                                                                                                                                                                                                                                 |
|--------------------|---------------------------------------------------------------------------------------------------------------------------------------------------------------------------------------------------------------------------------------------------------------------------------------------------------------------------------------------------------------------------------------------------------------------------------------------------------------------------------------------------------------------------------------------------------------------------------------------------------------------------------------------------------------------------------------------------------------------------------------------------------------------------------------------------------------------------------------------------------------------------------|
| <b>Syntax</b>      | <b>hold-time</b> {[ <b>up</b> <i>hold-time up</i> ] [ <b>down</b> <i>hold-time down</i> ] [ <b>seconds</b>   <b>centiseconds</b> ]}<br><b>no hold-time</b>                                                                                                                                                                                                                                                                                                                                                                                                                                                                                                                                                                                                                                                                                                                      |
| <b>Context</b>     | config>port>ethernet                                                                                                                                                                                                                                                                                                                                                                                                                                                                                                                                                                                                                                                                                                                                                                                                                                                            |
| <b>Description</b> | This command configures port link dampening timers which reduce the number of link transitions reported to upper layer protocols. The <b>hold-time</b> value is used to dampen interface transitions.<br>When an interface transitions from an up state to a down state, it is immediately advertised to the rest of the system if the hold-time down interval is zero, but if the hold-time down interval is greater than zero, interface down transitions are not advertised to upper layers until the hold-time down interval has expired. Likewise, an interface is immediately advertised as up to the rest of the system if the hold-time up interval is zero, but if the hold-time up interval is greater than zero, up transitions are not advertised until the hold-time up interval has expired.<br>The <b>no</b> form of this command reverts to the default values. |
| <b>Default</b>     | <b>down 0</b> seconds — No port link down dampening is enabled; link down transitions are immediately reported to upper layer protocols.<br><b>up 0</b> seconds — No port link up dampening is enabled; link up transitions are immediately reported to upper layer protocols.                                                                                                                                                                                                                                                                                                                                                                                                                                                                                                                                                                                                  |
| <b>Parameters</b>  | <b>up</b> <i>hold-time up</i> — — The delay, in seconds or centiseconds, to notify the upper layers after an interface transitions from a down state to an up state.<br><b>Values</b> 0 — 900 seconds<br>0, 10 — 90000 centiseconds in 5 centisecond increments<br><b>down</b> <i>hold-time down</i> — The delay, in seconds or centiseconds, to notify the upper layers after an interface                                                                                                                                                                                                                                                                                                                                                                                                                                                                                     |

## Ethernet Port Commands

transitions from an up state to a down state.

**Values** 0 — 900 seconds  
0, 10 — 90000 centiseconds in 5 centisecond increments

**seconds | centiseconds** — Specify the units of your hold time in **seconds** or **centiseconds**.

### lacp-tunnel

**Syntax** [no] lacp-tunnel

**Context** config>port>ethernet

**Description** This command enables LACP packet tunneling for the Ethernet port. When tunneling is enabled, the port will not process any LACP packets but will tunnel them instead. The port cannot be added as a member to a LAG group.

The **no** form of the command disables LACP packet tunneling for the Ethernet port.

**Default** no lacp-tunnel

### load-balancing-algorithm

**Syntax** load-balancing-algorithm *option*  
no load-balancing-algorithm

**Context** config>port>ethernet

**Description** This command specifies the load balancing algorithm to be used on this port.

In the default mode, **no load-balancing-algorithm**, the port inherits the global settings. The value is not applicable for ports that do not pass any traffic.

The configuration of load-balancing-algorithm at logical port level has three possible values:

- **include-l4** — Enables inherits system-wide settings including Layer 4 source and destination port value in hashing algorithm.
- **exclude-l4** — Layer 4 source and destination port value will not be included in hashing.
- **no load-balancing-algorithm** — Inherits system-wide settings.

The hashing algorithm addresses finer spraying granularity where many hosts are connected to the network. To address more efficient traffic distribution between network links (forming a LAG group), a hashing algorithm extension takes into account Layer 4 information (src/dst L4-protocol port).

The hashing index can be calculated according to the following algorithm:

```
If [(TCP or UDP traffic) & enabled]
 hash (<TCP/UDP ports>, <IP addresses>)
else if (IP traffic)
 hash (<IP addresses>)
else
```

```
hash (<MAC addresses>)
```

```
endif
```

This algorithm will be used in all cases where IP information in per-packet hashing is included (see [LAG and ECMP Hashing on page 50](#)). However the Layer 4 information (TCP/UDP ports) will not be used in the following cases:

- Fragmented packets

Default no load-balancing-algorithm

**Parameters** *option* — Specifies the load balancing algorithm to be used on this port.

**Values** **include-14** — Specifies that the source and destination ports are used in the hashing algorithm.  
**exclude-14** — Specifies that the source and destination ports are not used in the hashing algorithm.

## pbb-etype

**Syntax** **pbb-etype** [0x0600..0xffff]  
**no pbb-etype**

**Context** config>port>ethernet

**Default** 0x88E7

**Description** This command configures the Ethertype used for PBB encapsulation.

**Values** **0x0600..0xffff:** 1536 — 65535 (accepted in decimal or hex)

## qinq-etype

**Syntax** **qinq-etype** 0x0600..0xffff  
**no qinq-etype**

**Context** config>port>ethernet

**Description** This command configures the Ethertype used for Q-in-Q encapsulation. The **no** form of this command reverts the qinq-etype value to the default.

**Parameters** 0x0600..0xffff — Specifies the qinq-etype to expect.

**Values** 1536 — 65535 in decimal or hex formats.

### report-alarm

|                    |                                                                                                                                                                                                                                                                                               |
|--------------------|-----------------------------------------------------------------------------------------------------------------------------------------------------------------------------------------------------------------------------------------------------------------------------------------------|
| <b>Syntax</b>      | <b>[no] report-alarm [signal-fail] [remote] [local] [no-frame-lock] [lcd]</b>                                                                                                                                                                                                                 |
| <b>Context</b>     | config>port>ethernet                                                                                                                                                                                                                                                                          |
| <b>Description</b> | This command specifies when and if to generate alarms and alarm clear notifications for this port.                                                                                                                                                                                            |
| <b>Parameters</b>  | <b>signal-fail</b> — Reports an Ethernet signal lost alarm.<br><b>remote</b> — Reports remote faults.<br><b>local</b> — Reports local faults.<br><b>no-frame-lock</b> — Reports a 'not locked on the ethernet framing sequence' alarm.<br><b>lcd</b> — Reports a codegroup delineation error. |

### speed

|                    |                                                                                                                                                                                                                                                              |
|--------------------|--------------------------------------------------------------------------------------------------------------------------------------------------------------------------------------------------------------------------------------------------------------|
| <b>Syntax</b>      | <b>speed {10   100   1000}</b>                                                                                                                                                                                                                               |
| <b>Context</b>     | config>port>ethernet                                                                                                                                                                                                                                         |
| <b>Description</b> | This command configures the port speed of a Fast Ethernet port when autonegotiation is disabled. If the port is configured to autonegotiate this parameter is ignored. Speed cannot be configured for ports that are part of a Link Aggregation Group (LAG). |
| <b>Default</b>     | <b>100</b>                                                                                                                                                                                                                                                   |
| <b>Parameters</b>  | <b>10</b> — Sets the link to 10 mbps speed.<br><b>100</b> — Sets the link to 100 mbps speed.<br><b>1000</b> — Sets the link to 1000 mbps speed.                                                                                                              |

### ssm

|                    |                                                                 |
|--------------------|-----------------------------------------------------------------|
| <b>Syntax</b>      | <b>ssm</b>                                                      |
| <b>Context</b>     | config>port>ethernet                                            |
| <b>Description</b> | This command enables Ethernet Synchronous Status Message (SSM). |

## code-type

**Syntax** `code-type [sonet | sdh]`

**Context** `config>port>ethernet>ssm`

**Description** This command configures the encoding of synchronous status messages. For example, whether to use an SDH or SONET set of values. Configuring the network-type is only applicable to SyncE ports. It is not configurable on SONET/SDH ports. For the network-type, `sdh` refers to ITU-T G.781 Option I, while `sonet` refers to G.781 Option II (equivalent to Telcordia GR-253-CORE). For compatibility with Release 7.0, `sdh` is the default.

**Default** `sdh`

**Parameters** `sdh` — Specifies the values used on a G.781 Option 1 compliant network.  
`sonet` — Specifies the values used on a G.781 Option 2 compliant network.

## tx-dus

**Syntax** `[no] tx-dus`

**Context** `config>port>ethernet>ssm`  
`config>port>sonet-sdh`

**Description** This command forces the QL value transmitted from the SSM channel of the SONET/SDH port or the Synchronous Ethernet port to be set to QL-DUS/QL-DNU. This capability is provided to block the use of the interface from the SR/ESS for timing purposes.

**Default** `no tx-dus`

## xgig

**Syntax** `xgig {lan | wan}`

**Context** `config>port>ethernet`

**Description** This command configures a 10 Gbps interface to be in Local or Wide Area Network (LAN or WAN) mode. When configuring the port to be in WAN mode certain SONET/SDH parameters can be changed to reflect the SONET/SDH requirements for this port.  
 When the port is configured for LAN mode, all SONET/SDH parameters are pre-determined and not configurable.

**Default** `lan`

**Parameters** `lan` — Sets the port to operate in LAN mode  
`wan` — Sets the port to operate in WAN mode.

## crc-monitor

**Syntax** `crc-monitor`

**Context** `config>port>ethernet`

**Description** This command configures Ethernet CRC Monitoring parameters.

**Default** none

## sd-threshold

**Syntax** `[no] sd-threshold N [multiplier M]`

**Context** `config>port>ethernet>crc-monitor`

**Description** This command specifies the error rate at which to declare the Signal Degrade condition on an Ethernet interface. The value represents  $M \cdot 10^E - N$  a ratio of errored frames over total frames received over  $W$  seconds of the sliding window. The CRC errors on the interface are sampled once per second. A default of 10 seconds is used when there is no additional window-size configured. The multiplier keyword is optional. If the multiplier keyword is omitted or **no sd-threshold** is specified the multiplier will return to the default value of 1.

**Default** no sd-threshold

**Parameters** **value**  $N$  — Represents the rate of CRC errored Ethernet frames.

**Values** 1-9

**value**  $M$  — Represents the multiplier used to scale the CRC error ratio.

**Values** 1-9

## sf-threshold

**Syntax** `[no] sf-threshold N [multiplier M]`

**Context** `config>port>ethernet>crc-monitor`

**Description** This command specifies the error rate at which to declare the Signal Fail condition on an Ethernet interface. The value represents  $M \cdot 10^E - N$  errored frames over total frames received over  $W$  seconds of the sliding window. The CRC errors on the interface are sampled once per second. A default of 10 seconds is used when there is no additional window-size configured. The multiplier keyword is optional. If the multiplier keyword is omitted or **no sf-threshold** is specified the multiplier will return to the default value of 1.

**Default** no sf-threshold

**Parameters** **value**  $N$  — Represents the rate of CRC errored Ethernet frames.

**Values** 1-9

**value**  $M$  — Represents the multiplier used to scale the CRC error ratio.

**Values** 1-9

## window-size

**Syntax** [no] window-size *W*

**Context** config>port>ethernet>crc-monitor

**Description** This command specifies sliding window size over which the ethernet frames are sampled to detect signal fail or signal degrade conditions. The command is used jointly with the sf-threshold and the sd-threshold to configure the sliding window size.

**Default** 10

**Parameters** **value W** — The size of the sliding window in seconds over which the errors are measured.

**Values** 1-10

## down-on-internal-error

**Syntax** [no] down-on-internal-error

**Context** config>port>ethernet

**Description** This command configures the system to allow to bring a port operationally down in the event the systems has detected internal max transmit errors.

**Default** no down-on-internal-erro

## single-fiber

**Syntax** [no] single-fiber

**Context** config>port>ethernet  
config>port>sonet-sdh

**Description** This command enables packet gathering and redirection of IP packets from a single fiber (RX) port of the Ethernet or SONET/SDH interface and redistributes packets to other interfaces through either static routes or policy-based forwarding.

This parameter can be applied in conjunction with the strip-label command. If they are applied together, the port must have the single-fiber option configured before it can be associated with an interface that is configured with the strip-label option.

Once a port is configured with single-fiber, traffic will no longer be transmitted out of that port. This command can be used in conjunction with strip-label.

**Default** no single-fiber



---

## 802.1x Port Commands

### max-auth-req

**Syntax** `max-auth-req max-auth-request`

**Context** `config>port>ethernet>dot1x`

**Description** This command configures the maximum number of times that the 7950 SR will send an access request RADIUS message to the RADIUS server. If a reply is not received from the RADIUS server after the specified *number* attempts, the 802.1x authentication procedure is considered to have failed.

The **no** form of this command returns the value to the default.

**Default** 2

**Parameters** *max-auth-request* — The maximum number of RADIUS retries.

**Values** 1 — 10

### port-control

**Syntax** `port-control [auto | force-auth | force-unauth]`

**Context** `config>port>ethernet>dot1x`

**Description** This command configures the 802.1x authentication mode.

The **no** form of this command returns the value to the default.

**Default** force-auth

**Parameters** **force-auth** — Disables 802.1x authentication and causes the port to transition to the authorized state without requiring any authentication exchange. The port transmits and receives normal traffic without requiring 802.1x-based host authentication.

**force-unauth** — Causes the port to remain in the unauthorized state, ignoring all attempts by the hosts to authenticate. The switch cannot provide authentication services to the host through the interface.

**auto** — Enables 802.1x authentication. The port starts in the unauthorized state, allowing only EAPOL frames to be sent and received through the port. Both the 7950 SR and the host can initiate an authentication procedure. The port will remain in un-authorized state (no traffic except EAPOL frames is allowed) until the first client is authenticated successfully. After this, traffic is allowed on the port for all connected hosts.

## quiet-period

|                    |                                                                                                                                                                                                          |
|--------------------|----------------------------------------------------------------------------------------------------------------------------------------------------------------------------------------------------------|
| <b>Syntax</b>      | <b>quiet-period</b> <i>seconds</i><br><b>no quiet-period</b>                                                                                                                                             |
| <b>Context</b>     | config>port>ethernet>dot1x                                                                                                                                                                               |
| <b>Description</b> | This command configures the period between two authentication sessions during which no EAPOL frames are sent by the 7950 SR.<br><br>The <b>no</b> form of this command returns the value to the default. |
| <b>Default</b>     | 30                                                                                                                                                                                                       |
| <b>Parameters</b>  | <i>seconds</i> — Specifies the quiet period in seconds.<br><br><b>Values</b> 1 — 3600                                                                                                                    |

## radius-plcy

|                    |                                                                                                                                                                                                                                                                                                                                                                                                                       |
|--------------------|-----------------------------------------------------------------------------------------------------------------------------------------------------------------------------------------------------------------------------------------------------------------------------------------------------------------------------------------------------------------------------------------------------------------------|
| <b>Syntax</b>      | <b>radius-plcy</b> <i>name</i><br><b>no radius-plcy</b>                                                                                                                                                                                                                                                                                                                                                               |
| <b>Context</b>     | config>port>ethernet>dot1x                                                                                                                                                                                                                                                                                                                                                                                            |
| <b>Description</b> | This command configures the RADIUS policy to be used for 802.1x authentication. An 802.1x RADIUS policy must be configured (under config>security>dot1x) before it can be associated to a port. If the RADIUS policy-id does not exist, an error is returned. Only one 802.1x RADIUS policy can be associated with a port at a time.<br><br>The <b>no</b> form of this command removes the RADIUS policy association. |
| <b>Default</b>     | no radius-plcy                                                                                                                                                                                                                                                                                                                                                                                                        |
| <b>Parameters</b>  | <i>name</i> — Specifies an existing 802.1x RADIUS policy name.                                                                                                                                                                                                                                                                                                                                                        |

## re-auth-period

|                    |                                                                                                                                                                                                                         |
|--------------------|-------------------------------------------------------------------------------------------------------------------------------------------------------------------------------------------------------------------------|
| <b>Syntax</b>      | <b>re-auth-period</b> <i>seconds</i><br><b>no re-auth-period</b>                                                                                                                                                        |
| <b>Context</b>     | config>port>ethernet>dot1x                                                                                                                                                                                              |
| <b>Description</b> | This command configures the period after which re-authentication is performed. This value is only relevant if re-authentication is enabled.<br><br>The <b>no</b> form of this command returns the value to the default. |
| <b>Default</b>     | 3600                                                                                                                                                                                                                    |

**Parameters** *seconds* — The re-authentication delay period in seconds.

**Values** 1 — 9000

## re-authentication

**Syntax** **[no] re-authentication**

**Context** config>port>ethernet>dot1x

**Description** This command enables / disables periodic 802.1x re-authentication.

When re-authentication is enabled, the 7950 SR will re-authenticate clients on the port every re-auth-period seconds.

The **no** form of the command returns the value to the default.

**Default** re-authentication

## server-timeout

**Syntax** **server-timeout** *seconds*  
**no server-timeout**

**Context** config>port>ethernet>dot1x

**Description** This command configures the period during which the 7950 SR waits for the RADIUS server to respond to its access request message. When this timer expires, the 7950 SR will re-send the access request message, up to the specified number times.

The **no** form of this command returns the value to the default.

**Default** 30

**Parameters** *seconds* — The server timeout period in seconds.

**Values** 1 — 300

## supplicant-timeout

**Syntax** **supplicant-timeout** *seconds*  
**no supplicant-timeout**

**Context** config>port>ethernet>dot1x

**Description** This command configures the period during which the 7950 SR waits for a client to respond to its EAPOL messages. When the supplicant-timeout expires, the 802.1x authentication session is considered to have failed.

The **no** form of this command returns the value to the default.

## 802.1x Port Commands

**Default** 30

**Parameters** *seconds* — The server timeout period in seconds.

**Values** 1 — 300

### transmit-period

**Syntax** **transmit-period** *seconds*  
**no transmit-period**

**Context** config>port>ethernet>dot1x

**Description** This command configures the period after which the 7950 SR sends a new EAPOL request message. The **no** form of this command returns the value to the default.

**Default** 30

**Parameters** *seconds* — The server transmit period in seconds.

**Values** 1 — 300

### tunneling

**Syntax** **tunneling**  
**no tunneling**

**Context** config>port>ethernet>dot1x

**Description** This command enables the tunneling of untagged 802.1x frames received on a port and is supported only when the dot1x port-control is set to force-auth. 802.1x tunneling is applicable to both Epipe and VPLS services using either a null SAP or a default SAP on a dot1q port. When configured, untagged 802.1x frames will be switched into the service with the corresponding supported SAP. The **no** form of this command disables tunneling of untagged 802.1x frames.

**Default** no tunneling

### down-when-looped

**Syntax** **down-when-looped**

**Context** config>port>ethernet

**Description** This command configures Ethernet loop detection attributes.

## dot1x

|                    |                                                                                                                                                                                                                                                                                                             |
|--------------------|-------------------------------------------------------------------------------------------------------------------------------------------------------------------------------------------------------------------------------------------------------------------------------------------------------------|
| <b>Syntax</b>      | <b>dot1x</b>                                                                                                                                                                                                                                                                                                |
| <b>Context</b>     | config>port>ethernet                                                                                                                                                                                                                                                                                        |
| <b>Description</b> | This command enables access to the context to configure port-specific 802.1x authentication attributes. This context can only be used when configuring a Fast Ethernet, gigabit or 10Gig EthernetFast Ethernet, gigabit or 10Gig EthernetFast Ethernet or gigabit Ethernet LAN ports on an appropriate MDA. |

## keep-alive

|                    |                                                                                  |
|--------------------|----------------------------------------------------------------------------------|
| <b>Syntax</b>      | <b>keep-alive <i>timer</i></b><br><b>no keep-alive</b>                           |
| <b>Context</b>     | config>port>ethernet>dwl                                                         |
| <b>Description</b> | This command configures the time interval between keep-alive PDUs.               |
| <b>Default</b>     | no keep-alive                                                                    |
| <b>Parameters</b>  | <i>timer</i> — Specifies the time interval, in seconds, between keep-alive PDUs. |
| <b>Values</b>      | 1 — 120                                                                          |

## retry-timeout

|                    |                                                                                              |
|--------------------|----------------------------------------------------------------------------------------------|
| <b>Syntax</b>      | <b>retry-timeout <i>timer</i></b><br><b>no retry-timeout</b>                                 |
| <b>Context</b>     | config>port>ethernet>dwl                                                                     |
| <b>Description</b> | This command configures the minimum wait time before re-enabling port after loop detection.  |
| <b>Default</b>     | no retry-timeout                                                                             |
| <b>Parameters</b>  | <i>timer</i> — Specifies the minimum wait time before re-enabling port after loop detection. |
| <b>Values</b>      | 0, 10 — 160                                                                                  |

## use-broadcast-address

|                    |                                                                                                                                                                                     |
|--------------------|-------------------------------------------------------------------------------------------------------------------------------------------------------------------------------------|
| <b>Syntax</b>      | <b>[no] use-broadcast-address</b>                                                                                                                                                   |
| <b>Context</b>     | config>port>ethernet>dwl                                                                                                                                                            |
| <b>Description</b> | This command specifies whether or not the down when looped destination MAC address is the broadcast address, or the local port MAC address, as specified in the port's MAC address. |

---

## LLDP Port Commands

### lldp

|                    |                                                                                                                      |
|--------------------|----------------------------------------------------------------------------------------------------------------------|
| <b>Syntax</b>      | <b>lldp</b>                                                                                                          |
| <b>Context</b>     | config>port>ethernet                                                                                                 |
| <b>Description</b> | This command enables the context to configure Link Layer Discovery Protocol (LLDP) parameters on the specified port. |

### dest-mac

|                    |                                                                                                                                                                                                                                                                                                                          |
|--------------------|--------------------------------------------------------------------------------------------------------------------------------------------------------------------------------------------------------------------------------------------------------------------------------------------------------------------------|
| <b>Syntax</b>      | <b>dest-mac</b> { <i>bridge-mac</i> }                                                                                                                                                                                                                                                                                    |
| <b>Context</b>     | config>port>ethernet>lldp                                                                                                                                                                                                                                                                                                |
| <b>Description</b> | This command configures destination MAC address parameters.                                                                                                                                                                                                                                                              |
| <b>Parameters</b>  | <b>bridge-mac</b> — Specifies destination bridge MAC type to use by LLDP.<br><b>Values</b><br><b>nearest-bridge</b> — Specifies to use the nearest bridge.<br><b>nearest-non-tpmr</b> — Specifies to use the nearest non-Two-Port MAC Relay (TPMR) .<br><b>nearest-customer</b> — Specifies to use the nearest customer. |

### admin-status

|                    |                                                                                                                                                                                                                                                                                                                                                                                                                                                                                                                                                                                                                                                                          |
|--------------------|--------------------------------------------------------------------------------------------------------------------------------------------------------------------------------------------------------------------------------------------------------------------------------------------------------------------------------------------------------------------------------------------------------------------------------------------------------------------------------------------------------------------------------------------------------------------------------------------------------------------------------------------------------------------------|
| <b>Syntax</b>      | <b>admin-status</b> { <b>rx</b>   <b>tx</b>   <b>tx-rx</b>   <b>disabled</b> }                                                                                                                                                                                                                                                                                                                                                                                                                                                                                                                                                                                           |
| <b>Context</b>     | config>port>ethernet>lldp>dstmac                                                                                                                                                                                                                                                                                                                                                                                                                                                                                                                                                                                                                                         |
| <b>Description</b> | This command configures LLDP transmission/reception frame handling.                                                                                                                                                                                                                                                                                                                                                                                                                                                                                                                                                                                                      |
| <b>Parameters</b>  | <b>rx</b> — Specifies the LLDP agent will receive, but will not transmit LLDP frames on this port.<br><b>tx</b> — Specifies that the LLDP agent will transmit LLDP frames on this port and will not store any information about the remote systems connected.<br><b>tx-rx</b> — Specifies that the LLDP agent transmitw and receives LLDP frames on this port.<br><b>disabled</b> — Specifies that the LLDP agent does not transmit or receive LLDP frames on this port. If there is remote systems information which is received on this port and stored in other tables, before the port's admin status becomes disabled, then the information will naturally age out. |

## notification

- Syntax** [no] notification
- Context** config>port>ethernet>lldp>dstmac
- Description** This command enables LLDP notifications.  
The **no** form of the command disables LLDP notifications.

## tx-mgmt-address

- Syntax** tx-mgmt-address [system]  
no tx-mgmt-address
- Context** config>port>ethernet>lldp>dstmac
- Description** This command specifies which management address to transmit.  
The no form of the command resets value to the default.
- Default** no tx-mgmt-address
- Parameters** **system** — Specifies to use the system IP address. Note that the system address will only be transmitted once it has been configured if this parameter is specified.

## tx-tlvs

- Syntax** tx-tlvs [port-desc] [sys-name] [sys-desc] [sys-cap]  
no tx-tlvs
- Context** config>port>ethernet>lldp>dstmac
- Description** This command specifies which LLDP TLVs to transmit. The TX TLVS, defined as a bitmap, includes the basic set of LLDP TLVs whose transmission is allowed on the local LLDP agent by the network management. Each bit in the bitmap corresponds to a TLV type associated with a specific optional TLV. Organizationally-specific TLVs are excluded from the this bitmap.  
  
There is no bit reserved for the management address TLV type since transmission of management address TLVs are controlled by another object.  
  
The **no** form of the command resets the value to the default.  
no tx-tlvs
- Parameters** **port-desc** — Indicates that the LLDP agent should transmit port description TLVs.  
**sys-name** — Indicates that the LLDP agent should transmit system name TLVs.  
**sys-desc** — Indicates that the LLDP agent should transmit system description TLVs.  
**sys-cap** — Indicates that the LLDP agent should transmit system capabilities TLVs.

---

## Network Port Commands

### network

**Syntax**    **network**

**Context**    config>port>ethernet

**Description**    This command enables access to the context to configure network port parameters.

### accounting-policy

**Syntax**    **accounting-policy** *policy-id*  
**no accounting-policy**

**Context**    config>port>ethernet>access>egr>qgrp  
config>port>ethernet>access>ing>qgrp  
config>port>ethernet>network>egr>qgrp  
config>port>ethernet>network

**Description**    This command configures an accounting policy that can apply to an interface.

An accounting policy must be configured before it can be associated to an interface. If the accounting *policy-id* does not exist, an error is returned.

Accounting policies associated with service billing can only be applied to SAPs. Accounting policies associated with network ports can only be associated with interfaces. Only one accounting policy can be associated with an interface at a time.

The **no** form of this command removes the accounting policy association from the network interface, and the accounting policy reverts to the default.

**Default**    No accounting policies are specified by default. You must explicitly specify a policy. If configured, the accounting policy configured as the default is used.

**Parameters**    *policy-id* — The accounting *policy-id* of an existing policy. Accounting policies record either service (access) or network information. A network accounting policy can only be associated with the network port configurations. Accounting policies are configured in the config>log>accounting-policy context.

**Values**    1 — 99

## collect-stats

**Syntax** [no] collect-stats

**Context** config>port>ethernet>access>egr>qgrp  
 config>port>ethernet>access>ing>qgrp  
 config>port>ethernet>network>egr>qgrp  
 config>port>ethernet>network

**Description** This command enables the collection of accounting and statistical data for the network interface. When applying accounting policies, the data, by default, is collected in the appropriate records and written to the designated billing file.

When the **no collect-stats** command is issued, the statistics are still accumulated by the XCM cards, however, the CPU does not obtain the results and write them to the billing file.

If the **collect-stats** command is issued again (enabled), then the counters written to the billing file will include the traffic collected while the **no collect-stats** command was in effect.

**Default** no collect-stats

## queue-policy

**Syntax** queue-policy *name*  
 no queue-policy

**Context** config>port>ethernet>network

**Description** This command specifies the existing network queue policy which defines queue parameters such as CBS, high priority only burst size, MBS, CIR and PIR rates, as well as forwarding-class to queue mappings. The network-queue policy is defined in the **config>qos>network-queue** context.

**Default** default

**Parameters** *name* — Specifies an existing network-queue policy name.

---

## Interface Group Handler Commands

### interface-group-handler

|                    |                                                                                                                                                                                                                                                                                                                                                                                                                                 |
|--------------------|---------------------------------------------------------------------------------------------------------------------------------------------------------------------------------------------------------------------------------------------------------------------------------------------------------------------------------------------------------------------------------------------------------------------------------|
| <b>Syntax</b>      | <b>[no] interface-group-handler</b> <i>group-id</i>                                                                                                                                                                                                                                                                                                                                                                             |
| <b>Context</b>     | config                                                                                                                                                                                                                                                                                                                                                                                                                          |
| <b>Description</b> | <p>This command creates an interface group handler that can be associated with a number of independent IP links. The purpose of the group is to operationally disable all interfaces in a common group if the number of active links drops below the minimum interface threshold.</p> <p>The <b>no</b> form of this command deletes the interface group handler. All members must be removed before the IGH can be deleted.</p> |
| <b>Default</b>     | None                                                                                                                                                                                                                                                                                                                                                                                                                            |
| <b>Parameters</b>  | <i>group-id</i> — Identifies the specific Interface Group Handler.                                                                                                                                                                                                                                                                                                                                                              |
| <b>Values</b>      | 1—100                                                                                                                                                                                                                                                                                                                                                                                                                           |

### member

|                    |                                                                                                                                                                                                                                                                                                                                                                                                                                                                                                      |
|--------------------|------------------------------------------------------------------------------------------------------------------------------------------------------------------------------------------------------------------------------------------------------------------------------------------------------------------------------------------------------------------------------------------------------------------------------------------------------------------------------------------------------|
| <b>Syntax</b>      | <b>[no] member</b> <i>portid</i>                                                                                                                                                                                                                                                                                                                                                                                                                                                                     |
| <b>Context</b>     | config>interface-group-handler                                                                                                                                                                                                                                                                                                                                                                                                                                                                       |
| <b>Description</b> | <p>This command binds the specified port with the associate Interface Group Handler. Up to eight <b>member</b> commands can be issued to add multiple ports to the associated IGH. The <b>member</b> must be a port. It must be a physical port or channel in network mode, and not bound to any router interfaces. A port or channel cannot be a member of more than one IGH at the same time.</p> <p>The <b>no</b> form of this command removes the specified port ID from the associated IGH.</p> |
| <b>Default</b>     | None                                                                                                                                                                                                                                                                                                                                                                                                                                                                                                 |
| <b>Parameters</b>  | <i>portid</i> — Identifies the port to be associated with the interface group handler.                                                                                                                                                                                                                                                                                                                                                                                                               |

### threshold

|                    |                                                                                                                                                                                                                                                                                            |
|--------------------|--------------------------------------------------------------------------------------------------------------------------------------------------------------------------------------------------------------------------------------------------------------------------------------------|
| <b>Syntax</b>      | <b>threshold</b> <i>min</i><br><b>no threshold</b>                                                                                                                                                                                                                                         |
| <b>Context</b>     | config>interface-group-handler                                                                                                                                                                                                                                                             |
| <b>Description</b> | <p>This command identifies the minimum number of active links that must be present for the interface group handler to be active. A threshold of 1 effectively disables the effect of the interface group handler.</p> <p>The <b>no</b> form of this command resets the threshold to 1.</p> |

**Default** None

**Parameters** *min* — Specifies the minimum number of active links that must be present for the interface group handler to be active.

**Values** 1 — 8

---

## SONET/SDH Port Commands

### sonet-sdh

**Syntax** `sonet-sdh`

**Context** `config>port`

**Description** This command enables access to the context to configure SONET/SDH parameters for an Ethernet port in WAN PHY (xgig wan) mode.

The 10 Gigabit Ethernet LAN port also has SONET/SDH characteristics. However, these characteristics are predetermined and not configurable.

### clock-source

**Syntax** `clock-source {loop-timed | node-timed}`

**Context** `config>port>sonet-sdh`

**Description** This command configures the clock to be used for transmission of data out towards the line. The options are to use the locally recovered clock from the line's receive data stream or the node central reference.

| Sonet/SDH              | Loop Timed | Default    |
|------------------------|------------|------------|
| OC-768                 | Yes        | node-timed |
| OC-192                 | Yes        | loop-timed |
| OC-48                  | Yes        | loop-timed |
| OC-12                  | No         | node-timed |
| OC-3                   | No         | node-timed |
| Channelized OC-12      | Yes        | loop-timed |
| Channelized OC-3       | Yes        | loop-timed |
| Channelized ASAP OC-12 | Yes        | loop-timed |
| Channelized ASAP OC-3  | Yes        | loop-timed |
| CES OC-3               | Yes        | loop-timed |
| ATM OC-12              | No         | node-timed |
| ATM OC-3               | No         | node-timed |

Parameters **loop-timed** — The link recovers the clock from the received data stream.

**node-timed** — The link uses the internal clock when transmitting data.

## framing

|                    |                                                                                                            |
|--------------------|------------------------------------------------------------------------------------------------------------|
| <b>Syntax</b>      | <b>framing</b> {sonet   sdh}                                                                               |
| <b>Context</b>     | config>port>sonet-sdh                                                                                      |
| <b>Description</b> | This command specifies SONET/SDH framing to be either SONET or SDH.                                        |
| <b>Default</b>     | sonet                                                                                                      |
| <b>Parameters</b>  | <b>sonet</b> — Configures the port for SONET framing.<br><b>sdh</b> — Configures the port for SDH framing. |

## report-alarm

|                    |                                                                                                                                                                                                                                                                                                                                                                                                                                                                                                                                                                                                                                                                                                                                                                                                                                                                                                                                                                                                                                                                                                                                                                                                                                                                                                                                                                                                                                                                                                                                                                                                                                                |
|--------------------|------------------------------------------------------------------------------------------------------------------------------------------------------------------------------------------------------------------------------------------------------------------------------------------------------------------------------------------------------------------------------------------------------------------------------------------------------------------------------------------------------------------------------------------------------------------------------------------------------------------------------------------------------------------------------------------------------------------------------------------------------------------------------------------------------------------------------------------------------------------------------------------------------------------------------------------------------------------------------------------------------------------------------------------------------------------------------------------------------------------------------------------------------------------------------------------------------------------------------------------------------------------------------------------------------------------------------------------------------------------------------------------------------------------------------------------------------------------------------------------------------------------------------------------------------------------------------------------------------------------------------------------------|
| <b>Syntax</b>      | [no] report-alarm [loc] [lais] [lrdi] [ss1f] [lb2er-sd] [lb2er-sf] [slof] [slos] [lrei]                                                                                                                                                                                                                                                                                                                                                                                                                                                                                                                                                                                                                                                                                                                                                                                                                                                                                                                                                                                                                                                                                                                                                                                                                                                                                                                                                                                                                                                                                                                                                        |
| <b>Context</b>     | config>port>sonet-sdh                                                                                                                                                                                                                                                                                                                                                                                                                                                                                                                                                                                                                                                                                                                                                                                                                                                                                                                                                                                                                                                                                                                                                                                                                                                                                                                                                                                                                                                                                                                                                                                                                          |
| <b>Description</b> | This command enables logging of SONET (SDH) line and section alarms for a SONET-SDH port. Only line and section alarms can be configured in the SONET/SDH context, for path alarms see the <b>sonet-sdh&gt;path</b> context.<br><br>The <b>no</b> form of this command disables logging of the specified alarms                                                                                                                                                                                                                                                                                                                                                                                                                                                                                                                                                                                                                                                                                                                                                                                                                                                                                                                                                                                                                                                                                                                                                                                                                                                                                                                                |
| <b>Parameters</b>  | <p><b>loc</b> — Reports a loss of clock which causes the operational state of the port to be shut down.</p> <p><b>Default</b> <b>loc</b> alarms are issued.</p> <p><b>lais</b> — Reports line alarm indication signal errors. When configured, <b>lais</b> alarms are raised and cleared.</p> <p><b>Default</b> <b>lais</b> alarms are not issued.</p> <p><b>lrdi</b> — Reports line remote defect indication errors. LRDI's are caused by remote LOF, LOC, LOS. When configured, <b>lrdi</b> alarms are raised and cleared.</p> <p><b>Default</b> <b>lrdi</b> alarms are issued.</p> <p><b>ss1f</b> — Reports section synchronization failure which is detected when the S1 byte is not consistent for 8 consecutive frames. When configured, <b>ss1f</b> alarms are raised and cleared.</p> <p><b>Default</b> <b>ss1f</b> alarms are not issued.</p> <p><b>lb2er-sd</b> — Reports line signal degradation BER (bit interleaved parity) errors. Use the threshold command to set the error rate(s) that when crossed determine signal degradation and signal failure. When configured, <b>lb2er-sd</b> alarms are raised and cleared.</p> <p><b>Default</b> <b>lb2er-sd</b> alarms are not issued.</p> <p><b>lb2er-sf</b> — Reports line signal failure BER errors. Use the threshold command to set the error rate(s) that when crossed determine signal degradation and signal failure. When configured, <b>lb2er-sf</b> alarms are raised and cleared.</p> <p><b>Default</b> <b>lb2er-sf</b> alarms are issued.</p> <p><b>slof</b> — Reports section loss of frame errors. When configured, <b>slof</b> alarms are raised and cleared.</p> |

## SONET/SDH Port Commands

**Default** **slof** alarms are issued.

**slos** — Reports a section loss of signal error on the transmit side. When configured, **slos** alarms are raised and cleared.

**Default** **slos** alarms are issued.

**lrei** — Reports a line error condition raised by the remote as a result of b1 errors received from this node. When configured, **lrei** traps are raised but not cleared

**Default** **lrei** traps are not issued.

### section-trace

**Syntax** **section-trace** {**increment-z0** | **byte** *value* | **string** *string*}

**Context** config>port>sonet-sdh

**Description** This command configures the section trace bytes in the SONET section header to interoperate with some older versions of ADMs or regenerators that require an incrementing STM ID. You can explicitly configure an incrementing STM value rather than a static one in the SDH overhead by specifying the z0-increment.

**Default** byte *0x1*

**Parameters** *increment-z0* — Configure an incrementing STM ID instead of a static value.

**byte** *value* — Set values in SONET header bytes.

**Default** 0x1

**Values** 0 — 255 or 0x00 — 0xFF

**string** *string* — Specifies a text string that identifies the section.

**Values** A string up to 16 bytes.

### suppress-lo-alarm

**Syntax** [**no**] **suppress-lo-alarm**

**Context** config>port>sonet-sdh

**Description** This command enables the suppression of lower order alarms on SONET/SDH port.  
The **no** form of the command disables the suppression of lower order alarms on SONET/SDH port.

## tx-dus

**Syntax** [no] tx-dus

**Context** config>port>ethernet>ssm  
config>port>sonet-sdh

**Description** This command forces the QL value transmitted from the SSM channel of the SONET/SDH port or the Synchronous Ethernet port to be set to QL-DUS/QL-DNU. This capability is provided to block the use of the interface from the SR/ESS for timing purposes.

**Default** no tx-dus

## threshold

**Syntax** threshold {ber-sd | ber-sf} rate *threshold-rate*  
no threshold {ber-sd | ber-sf}

**Context** config>port>sonet-sdh

**Description** This command configures the line signal degradation bit error rate (BER) and line signal failure thresholds. Line signal (b2) bit interleaved parity error rates are measured and when they cross either the degradation or failure thresholds alarms are raised (see the report-alarm line & section command), furthermore if the failure threshold is crossed the link will be set to operationally down.

The **no** form of this command reverts to the default value.

**Default** threshold ber-sf 6 — Signal degrade BER threshold of  $10^{-6}$

threshold ber-sf 3 — Signal failure BER threshold of  $10^{-3}$

**Parameters** ber-sd — Specifies the BER that specifies signal degradation

ber-sf — Specifies the BER that specifies signal failure

rate — The BER negative exponent (n in  $10^{-n}$ ), expressed as a decimal integer.

**Values** 3 — 9 ( $10^{-3}$  —  $10^{-9}$ )

---

## SONET/SDH Path Commands

### path

|                    |                                                                                                                                                                                                                                                                                                      |
|--------------------|------------------------------------------------------------------------------------------------------------------------------------------------------------------------------------------------------------------------------------------------------------------------------------------------------|
| <b>Syntax</b>      | <b>[no] path</b> [ <i>sonet-sdh-index</i> ]                                                                                                                                                                                                                                                          |
| <b>Context</b>     | config>port>sonet-sdh                                                                                                                                                                                                                                                                                |
| <b>Description</b> | This command defines the SONET/SDH path.<br>The <b>no</b> form of this command removes the specified SONET/SDH path.                                                                                                                                                                                 |
| <b>Default</b>     | full channel (or clear channel)                                                                                                                                                                                                                                                                      |
| <b>Parameters</b>  | <i>sonet-sdh-index</i> — Specifies the components making up the specified SONET/SDH path. Depending on the type of SONET/SDH port the <i>sonet-sdh-index</i> must specify more path indexes to specify the payload location of the path. The <i>sonet-sdh-index</i> differs for SONET and SDH ports. |
| <b>Values</b>      | sts192                                                                                                                                                                                                                                                                                               |

### report-alarm

|                    |                                                                                                                                                                                                                                                                                                                                                                                                                                                                                                                                                                                                                                                                                                                                                                                                                                                                                                                                                                                                                                                         |
|--------------------|---------------------------------------------------------------------------------------------------------------------------------------------------------------------------------------------------------------------------------------------------------------------------------------------------------------------------------------------------------------------------------------------------------------------------------------------------------------------------------------------------------------------------------------------------------------------------------------------------------------------------------------------------------------------------------------------------------------------------------------------------------------------------------------------------------------------------------------------------------------------------------------------------------------------------------------------------------------------------------------------------------------------------------------------------------|
| <b>Syntax</b>      | <b>[no] report-alarms</b> [ <b>pais</b> ] [ <b>plop</b> ] [ <b>prdi</b> ] [ <b>pplm</b> ] [ <b>prei</b> ] [ <b>puneq</b> ] [ <b>plcd</b> ]                                                                                                                                                                                                                                                                                                                                                                                                                                                                                                                                                                                                                                                                                                                                                                                                                                                                                                              |
| <b>Context</b>     | config>port>sonet-sdh>path                                                                                                                                                                                                                                                                                                                                                                                                                                                                                                                                                                                                                                                                                                                                                                                                                                                                                                                                                                                                                              |
| <b>Description</b> | This command enables logging of SONET (SDH) path alarms for a SONET-SDH port. Only path alarms can be configured in the channel context.<br>The <b>no</b> form of this command disables logging of the specified alarms.                                                                                                                                                                                                                                                                                                                                                                                                                                                                                                                                                                                                                                                                                                                                                                                                                                |
| <b>Parameters</b>  | <p><b>pais</b> — Reports path alarm indication signal errors. When configured, <b>pais</b> alarms are raised and cleared.</p> <p><b>Default</b> <b>pais</b> alarms are not issued</p> <p><b>plop</b> — Reports path loss of pointer (per tributary) errors. When configured, <b>plop</b> traps are raised but not cleared.</p> <p><b>Default</b> <b>plop</b> traps are issued</p> <p><b>prdi</b> — Reports path remote defect indication errors. When configured, <b>prdi</b> alarms are raised and cleared.</p> <p><b>Default</b> <b>prdi</b> alarms are not issued</p> <p><b>pplm</b> — Reports a path payload mismatch, as a result the channel will be operationally downed. When configured, <b>pplm</b> traps are raised but not cleared.</p> <p><b>Default</b> <b>pplm</b> traps are issued</p> <p><b>prei</b> — Reports a path error condition raised by the remote as a result of b3 errors received from this node. When configured, <b>prei</b> traps are raised but not cleared.</p> <p><b>Default</b> <b>prei</b> traps are not issued</p> |

**puneq** — Reports path unequipped errors. Reports path unequipped signal errors.

**Default** puneq traps are issued

**plcd** — Reports path loss of codegroup delineation errors. It is applicable only when the value of xgig is set to WAN.

**Default** plcd traps are not issued

## report-alarm

**Syntax** [no] report-alarm {pais | plop | prdi | pplm | prei}

**Context** config>port>sonet-sdh>path

**Description** This command enables logging of SONET (SDH) path alarms for a SONET-SDH port. Only path alarms can be configured in the channel context.

The **no** form of this command disables logging of the specified alarms.

**Parameters** **pais** — Reports path alarm indication signal errors. When configured, **pais** alarms are raised and cleared.

**Default** pais alarms are not issued

**plop** — Reports path loss of pointer (per tributary) errors. When configured, **plop** traps are raised but not cleared.

**Default** plop traps are issued

**prdi** — Reports path remote defect indication errors. When configured, **prdi** alarms are raised and cleared.

**Default** prdi alarms are not issued

**pplm** — Reports a path payload mismatch, as a result the channel will be brought down. When configured, **pplm** traps are raised but not cleared.

**Default** pplm traps are issued

**prei** — Reports a path error condition raised by the remote as a result of b3 errors received from this node. When configured, **prei** traps are raised but not cleared

**Default** prei traps are not issued

## signal-label

**Syntax** signal-label *value*

**Context** config>port>sonet-sdh>path

**Description** This command sets the C2 byte value. The purpose of this byte is to communicate the payload type being encapsulated by SONET framing.

**Default** 0xcf

## SONET/SDH Path Commands

**Parameters** *value* — Specifies the C2 byte value, expressed as a decimal integer or a value in hex format.

**Values** 1 — 254 or 0x01 — 0xfe

### trace-string

**Syntax** **trace-string** [*trace-string*]  
**no trace-string**

**Context** config>port> sonet-sdh>path

**Description** This command specifies that a J1-path-trace that identifies the circuit is inserted continuously at source. This can be checked against the expected value by the receiver. If no trace string is entered then a null string is used.

The **no** form of this command resets the string to its default.

**Default** The default J1 value is Alcatel-Lucent XXX YYY (for example, Alcatel 7750 SR) where XXX is the platform name, such as "7750", and YYY is the product name, such as "SR" or "ESS". The value does not change when the encap-type changes. The J1 string contains all zeros for a non-provisioned path.

**Parameters** *trace-string* — Specifies either a string up to 62 bytes for SONET or 15 bytes for SDH. If the string contains spaces, enclose it in quotation marks.

---

## LAG Commands

### lag

**Syntax** [no] lag [*lag-id*]

**Context** config

**Description** This command creates the context for configuring Link Aggregation Group (LAG) attributes.

A LAG can be used to group multiple ports into one logical link. The aggregation of multiple physical links allows for load sharing and offers seamless redundancy. If one of the links fails, traffic will be redistributed over the remaining links.

**NOTE:** All ports in a LAG group must have autonegotiation set to Limited or Disabled.

There are three possible settings for autonegotiation:

- “on” or enabled with full port capabilities advertised
- “off” or disabled where there is no autonegotiation advertisements
- “limited” where a single speed/duplex is advertised.

When autonegotiation is enabled on a port, the link attempts to automatically negotiate the link speed and duplex parameters. If autonegotiation is enabled, the configured duplex and speed parameters are ignored.

When autonegotiation is disabled on a port, the port does not attempt to autonegotiate and will only operate at the **speed** and **duplex** settings configured for the port. Note that disabling autonegotiation on gigabit ports is not allowed as the IEEE 802.3 specification for gigabit Ethernet requires autonegotiation be enabled for far end fault indication.

If the **autonegotiate limited** keyword option is specified the port will autonegotiate but will only advertise a specific speed and duplex. The speed and duplex advertised are the **speed** and **duplex** settings configured for the port. One use for limited mode is for multispeed gigabit ports to force gigabit operation while keeping autonegotiation is enabled for compliance with IEEE 801.3.

The system requires that autonegotiation be disabled or limited for ports in a LAG to guarantee a specific port speed.

The **no** form of this command deletes the LAG from the configuration. Deleting a LAG can only be performed while the LAG is administratively shut down. Any dependencies such as IP-Interfaces configurations must be removed from the configuration before issuing the **no lag** command.

**Default** No LAGs are defined.

**Parameters** *lag-id* — The LAG identifier, expressed as a decimal integer.

**Values** 1 — 200

## LAG Commands

### access

**Syntax** `access`

**Context** `config>lag`

**Description** This command enables the context to configure access parameters.

### adapt-qos

**Syntax** `adapt-qos {link | distribute [include-egr-hash-cfg]}`

**Context** `config>lag>access`

**Description** This command specifies how the LAG SAP queue and virtual scheduler buffering and rate parameters are adapted over multiple active XMAS/MDAs. This command applies only to access LAGs.

**Default** `distribute`

**Parameters** *type* — Specify the QoS adaptation type.

**Values**

- link** — Specifies that the LAG will create the SAP queues and virtual schedulers with the actual parameters on each LAG member port.
- distribute** — Creates an additional internal virtual scheduler per IOMXCM as parent of the configured SAP queues and virtual schedulers per LAG member port on that IOMXCM. This internal virtual scheduler limits the total amount of egress bandwidth for all member ports on the IOMXCM to the bandwidth specified in the egress qos policy.
- include-egr-hash-cfg** — Specifies whether explicitly configured hashing should factor into the egress buffering and rate distribution. When this parameter is configured, all SAPs on this LAG which have explicit hashing configured, the egress HQos and HPol (including queues, policers, schedulers and arbiters) will receive 100% of the configured bandwidth (essentially operating in adapt-qos link mode). For any Multi-Service-Sites assigned to such a LAG, bandwidth will continue to be divided according to adapt-qos distribute mode.

### per-fp-sap-instance

**Syntax** `[no] per-fp-sap-instance`

**Context** `config>lag>access`

**Description** This command enables optimized SAP instance allocation on a LAG. When enabled, SAP instance is allocated per each FP the LAG links exits on instead of per each LAG port.

The **no** form of this command disables optimized SAP instance allocation.

**Default** `no per-fp-sap-instance`

## per-fp-egr-queuing

**Syntax** [no] per-fp-egr-queuing

**Context** config>lag

**Description** This command specifies whether a more efficient method of queue allocation for LAG SAPs should be utilized.

The **no** form of the command disables the method of queue allocation for LAG SAPs.

## per-fp-ing-queuing

**Syntax** [no] per-fp-ing-queuing

**Context** config>lag

**Description** This command specifies whether a more efficient method of queue allocation for LAG SAPs should be utilized.

The **no** form of the command disables the method of queue allocation for LAG SAPs.

## bfd

**Syntax** bfd

**Context** config>lag

**Description** This command creates the bfd context and enables BFD over the associated LAG links.

## family

**Syntax** family [ipv4 | ipv6]  
no family

**Context** config>lag>bfd

**Description** This command is used to specify which address family should be used for the micro-BFD session over the associated LAG links.

**Default** None

**Parameters** **ipv4** — IPv4 encapsulation should be used for the micro-BFD session.

**ipv6** — IPv6 encapsulation should be used for the micro-BFD session.

## bfd-on-distributing-only

|                    |                                                                                                                                                                      |
|--------------------|----------------------------------------------------------------------------------------------------------------------------------------------------------------------|
| <b>Syntax</b>      | <b>[no] bfd-on-distributing-only</b>                                                                                                                                 |
| <b>Context</b>     | config>lag>bfd>family                                                                                                                                                |
| <b>Description</b> | This command enables restricting micro-BFD sessions to links in LACP state distributing. The <b>no</b> form of the command disables restricting micro-BFD sessions . |
| <b>Default</b>     | no bfd-on-distributing-only                                                                                                                                          |

## local-ip-address

|                    |                                                                                                                                                                                                                                                                                             |               |         |               |                                     |  |                   |  |                |  |               |
|--------------------|---------------------------------------------------------------------------------------------------------------------------------------------------------------------------------------------------------------------------------------------------------------------------------------------|---------------|---------|---------------|-------------------------------------|--|-------------------|--|----------------|--|---------------|
| <b>Syntax</b>      | <b>local-ip-address</b> <i>ip-address</i><br><b>no local-ip-address</b>                                                                                                                                                                                                                     |               |         |               |                                     |  |                   |  |                |  |               |
| <b>Context</b>     | config>lag>bfd>family                                                                                                                                                                                                                                                                       |               |         |               |                                     |  |                   |  |                |  |               |
| <b>Description</b> | This command is used to specify the IPv4 or IPv6 address of the BFD source. The <b>no</b> form of the command removes this address from the configuration.                                                                                                                                  |               |         |               |                                     |  |                   |  |                |  |               |
| <b>Default</b>     | no local-ip-address                                                                                                                                                                                                                                                                         |               |         |               |                                     |  |                   |  |                |  |               |
| <b>Parameters</b>  | <i>ip-address</i> — Specifies the IP address.                                                                                                                                                                                                                                               |               |         |               |                                     |  |                   |  |                |  |               |
| <b>Values</b>      | <table> <tr> <td>ipv4-address:</td> <td>a.b.c.d</td> </tr> <tr> <td>ipv6-address:</td> <td>x:x:x:x:x:x:x (eight 16-bit pieces)</td> </tr> <tr> <td></td> <td>x:x:x:x:x:d.d.d.d</td> </tr> <tr> <td></td> <td>x: [0 — FFFF]H</td> </tr> <tr> <td></td> <td>d: [0 — 255]D</td> </tr> </table> | ipv4-address: | a.b.c.d | ipv6-address: | x:x:x:x:x:x:x (eight 16-bit pieces) |  | x:x:x:x:x:d.d.d.d |  | x: [0 — FFFF]H |  | d: [0 — 255]D |
| ipv4-address:      | a.b.c.d                                                                                                                                                                                                                                                                                     |               |         |               |                                     |  |                   |  |                |  |               |
| ipv6-address:      | x:x:x:x:x:x:x (eight 16-bit pieces)                                                                                                                                                                                                                                                         |               |         |               |                                     |  |                   |  |                |  |               |
|                    | x:x:x:x:x:d.d.d.d                                                                                                                                                                                                                                                                           |               |         |               |                                     |  |                   |  |                |  |               |
|                    | x: [0 — FFFF]H                                                                                                                                                                                                                                                                              |               |         |               |                                     |  |                   |  |                |  |               |
|                    | d: [0 — 255]D                                                                                                                                                                                                                                                                               |               |         |               |                                     |  |                   |  |                |  |               |

## max-admin-down-time

|                    |                                                                                                                                                                                                                                                                                                                                                                                                                                                                                                                      |
|--------------------|----------------------------------------------------------------------------------------------------------------------------------------------------------------------------------------------------------------------------------------------------------------------------------------------------------------------------------------------------------------------------------------------------------------------------------------------------------------------------------------------------------------------|
| <b>Syntax</b>      | <b>max-admin-down-time</b> [ <i>down-interval</i>   <b>infinite</b> ]<br><b>no max-admin-down-time</b>                                                                                                                                                                                                                                                                                                                                                                                                               |
| <b>Context</b>     | config>lag>bfd>family                                                                                                                                                                                                                                                                                                                                                                                                                                                                                                |
| <b>Description</b> | This command specifies the maximum amount of time the router will continue to forward traffic over a link after the micro-BFD sessions has transitioned to a Down state because it received an ADMIN-DOWN state from the far-end. This timer provide the administrator the configured amount of time to disable or de-provision the micro-BFD session on the local node before forwarding is halted over the associated link(s). The <b>no</b> form of the command removes the time interval from the configuration. |
| <b>Default</b>     | no max-admin-down-time                                                                                                                                                                                                                                                                                                                                                                                                                                                                                               |
| <b>Parameters</b>  | <i>down-interval</i> — Specifies the amount of time, in seconds.                                                                                                                                                                                                                                                                                                                                                                                                                                                     |
| <b>Values</b>      | -1—3600                                                                                                                                                                                                                                                                                                                                                                                                                                                                                                              |

**infinite** — Specifies no end time to forward traffic.

## max-setup-time

**Syntax** **max-setup-time** [*up-interval* | **infinite**]  
**no max-setup-time**

**Context** config>lag>bfd>family

**Description** This command specifies the maximum amount of time the router will forward traffic over a link that has transitioned from Standby to Active, before the micro-BFD session must be fully established (Up state).  
 The **no** form of the command returns the timer value to the default (0) which indicates that forwarding will not start until the BFD session is established.

**Default** no max-setup-time

**Parameters** *up-interval* — Specifies the amount of time, in milliseconds.

**Values** -1—60000

**infinite** — Specifies no end time to forward traffic.

## multiplier

**Syntax** **multiplier** *multiplier*  
**no multiplier**

**Context** config>lag>bfd>family

**Description** This command specifies the detect multiplier used for a micro-BFD session over the associated LAG links. If a BFD control packet is not received for a period of multiplier X receive-interval then the session is declared down.

The **no** form of the command removes multiplier from the configuration.

**Default** no multiplier

**Parameters** *multiplier* — Specifies the multiplier value.

**Values** 3—20

## receive-interval

**Syntax** **receive-interval** *receive-interval*  
**no receive-interval**

**Context** config>lag>bfd>family

**Description** This command specifies the receive timer used for micro-BFD session over the associated LAG links.

## LAG Commands

The **no** form of the command removes the receive timer from the configuration.

**Default** no receive-interval

**Parameters** *receive-interval* — Specifies the interval value, in milliseconds.

**Values** 10—100000

**Default** 100 ms for CPM3 or later, 1 sec for all other

## remote-ip-address

**Syntax** **remote-ip-address** *ip-address*  
**no remote-ip-address**

**Context** config>lag>bfd>family

**Description** This command is used to specify the IPv4 or IPv6 address of the BFD destination.  
The **no** form of the command removes this address from the configuration.

**Default** no remote-ip-address

**Parameters** *ip-address* — Specifies the IP address.

**Values** ipv4-address: a.b.c.d  
ipv6-address: x:x:x:x:x:x:x (eight 16-bit pieces)  
x:x:x:x:x:d.d.d.d  
x: [0 — FFFF]H  
d: [0 — 255]D

## transmit-interval

**Syntax** **transmit-interval** *transmit-interval*  
**no transmit-interval**

**Context** config>lag>bfd>family

**Description** This command specifies the transmit timer used for micro-BFD session over the associated LAG links.  
The **no** form of the command removes the transmit timer from the configuration.

**Default** no transmit-interval

**Parameters** *transmit-interval* — Specifies the interval value, in milliseconds.

**Values** 10—100000

**Default** 100 ms for CPM3 or later, 1 sec for all other

## shutdown

**Syntax**    **shutdown**  
**no shutdown**

**Context**    config>lag>bfd>family

**Description**    This command disables micro BFD sessions for this address family.  
 The **no** form of the command re-enables micro BFD sessions for this address family.

**Default**    no transmit-interval

## dynamic-cost

**Syntax**    [no] **dynamic-cost**

**Context**    config>lag *lag-id*

**Description**    This command enables OSPF/ISIS costing of a Link Aggregation Group (LAG) based on the available aggregated, operational bandwidth.

The path cost is dynamically calculated based on the interface bandwidth. OSPF path cost can be changed through the interface metric or the reference bandwidth.

If dynamic cost is configured, then costing is applied based on the total number of links configured and the cost advertised is inversely proportional to the number of links available at the time. This is provided that the number of links that are up exceeds the configured LAG threshold value at which time the configured threshold action determines if, and at what cost, this LAG will be advertised.

For example:

Assume a physical link in OSPF has a cost associated with it of 100, and the LAG consists of four physical links. The cost associated with the logical link is 25. If one link fails then the cost would automatically be adjusted to 33.

If dynamic cost is not configured and OSPF autocost is configured, then costing is applied based on the total number of links configured. This cost will remain static provided the number of links that are up exceeds the configured LAG threshold value at which time the configured threshold action determines if and at what cost this LAG will be advertised.

If dynamic-cost is configured and OSPF autocost is not configured, the cost is determined by the cost configured on the OSPF metric provided the number of links available exceeds the configured LAG threshold value at which time the configured threshold action determines if this LAG will be advertised.

If neither dynamic-cost nor OSPF autocost are configured, the cost advertised is determined by the cost configured on the OSPF metric provided the number of links available exceeds the configured LAG threshold value at which time the configured threshold action determines if this LAG will be advertised.

The **no** form of this command removes dynamic costing from the LAG.

**Default**    no dynamic-cost

## encap-type

|                    |                                                                                                                                                                                                                                                                                                                                                                                                                                                                                                                                                                                                                                                                               |
|--------------------|-------------------------------------------------------------------------------------------------------------------------------------------------------------------------------------------------------------------------------------------------------------------------------------------------------------------------------------------------------------------------------------------------------------------------------------------------------------------------------------------------------------------------------------------------------------------------------------------------------------------------------------------------------------------------------|
| <b>Syntax</b>      | <b>encap-type</b> {dot1q   null   qinq}<br><b>no encap-type</b>                                                                                                                                                                                                                                                                                                                                                                                                                                                                                                                                                                                                               |
| <b>Context</b>     | config>lag                                                                                                                                                                                                                                                                                                                                                                                                                                                                                                                                                                                                                                                                    |
| <b>Description</b> | <p>This command configures the encapsulation method used to distinguish customer traffic on a LAG. The encapsulation type is configurable on a LAG port. The LAG port and the port member encapsulation types must match when adding a port member.</p> <p>If the encapsulation type of the LAG port is changed, the encapsulation type on all the port members will also change. The encapsulation type can be changed on the LAG port only if there is no interface associated with it. If the MTU is set to a non default value, it will be reset to the default value when the encap type is changed.</p> <p>The <b>no</b> form of this command restores the default.</p> |
| <b>Default</b>     | <b>null</b> — All traffic on the port belongs to a single service or VLAN.                                                                                                                                                                                                                                                                                                                                                                                                                                                                                                                                                                                                    |
| <b>Parameters</b>  | <p><b>dot1q</b> — Ingress frames carry 802.1Q tags where each tag signifies a different service.</p> <p><b>null</b> — Ingress frames will not use any tags to delineate a service. As a result, only one service can be configured on a port with a null encapsulation type.</p> <p><b>qinq</b> — Specifies QinQ encapsulation.</p>                                                                                                                                                                                                                                                                                                                                           |

## hold-time

|                    |                                                                                                                                                                                                                                                                                                                                                                                                                                                                          |
|--------------------|--------------------------------------------------------------------------------------------------------------------------------------------------------------------------------------------------------------------------------------------------------------------------------------------------------------------------------------------------------------------------------------------------------------------------------------------------------------------------|
| <b>Syntax</b>      | <b>hold-time down</b> <i>hold-down-time</i><br><b>no hold-time</b>                                                                                                                                                                                                                                                                                                                                                                                                       |
| <b>Context</b>     | config>lag                                                                                                                                                                                                                                                                                                                                                                                                                                                               |
| <b>Description</b> | <p>This command specifies the timer, in tenths of seconds, which controls the delay between detecting that a LAG is down (all active ports are down) and reporting it to the higher levels.</p> <p>A non-zero value can be configured, for example, when active/standby signalling is used in a 1:1 fashion to avoid informing higher levels during the small time interval between detecting that the LAG is down and the time needed to activate the standby link.</p> |
| <b>Default</b>     | 0                                                                                                                                                                                                                                                                                                                                                                                                                                                                        |
| <b>Parameters</b>  | <b>down</b> <i>hold-down-time</i> — Specifies the hold-time for event reporting                                                                                                                                                                                                                                                                                                                                                                                          |
| <b>Values</b>      | 0 — 2000                                                                                                                                                                                                                                                                                                                                                                                                                                                                 |

## lacp

**Syntax** **lacp** [*mode*] [**administrative-key** *admin-key*] [**system-id** *system-id*][**system-priority** *priority*]

**Context** config>lag

**Description** This command specifies the LACP mode for aggregated Ethernet interfaces only. This command enables the LACP protocol. Per the IEEE 802.3ax standard (formerly 802.3ad), the Link Aggregation Control Protocol (LACP) provides a standardized means for exchanging information between Partner Systems on a link to allow their Link Aggregation Control instances to reach agreement on the identity of the Link Aggregation Group to which the link belongs, move the link to that Link Aggregation Group, and enable its transmission and reception functions in an orderly manner.

**Default** no lacp

**Parameters** *mode* — Specifies the mode in which LACP will operate.

**Values** **passive** — Starts transmitting LACP packets only after receiving packets.  
**active** — Initiates the transmission of LACP packets.  
**power-off** — Disables transmitter of standby ports.

**administrative-key** *admin-key* — Specifies an administrative key value to identify the channel group on each port configured to use LACP. This value should be configured only in exceptional cases. If it is not specified, a random key is assigned.

**Values** 1 — 65535

## lacp-xmit-interval

**Syntax** **lacp-xmit-interval** {**slow** | **fast**}

**Context** config>lag

**Description** This command specifies the interval signaled to the peer and tells the peer at which rate it should transmit.

**Default** fast

**Parameters** **slow** — Transmits packets every 30 seconds.

**fast** — Transmits packets every second.

## lacp-xmit-stdby

**Syntax** [**no**] **lacp-xmit-stdby**

**Context** config>lag

**Description** This command enables LACP message transmission on standby links.

The **no** form of this command disables LACP message transmission. This command should be disabled for compatibility when using active/standby groups. This forces a timeout of the standby links by the peer. Use the **no** form if the peer does not implement the correct behavior regarding the lacp sync bit.

## LAG Commands

**Default** lacp-xmit-stdby

### link-map-profile

**Syntax** **link-map-profile** *link-map-profile-id* [**create**]  
**no link-map-profile** *link-map-profile-id*

**Context** config>lag

**Description** This command creates the link map profile that can to control which LAG ports are to be used on egress or enables the configuration context for previously created link map profile.

The **no** form of this command, deletes the specified link map profile.

**Default** Link-map-profiles are not created by default.

**Parameters** *link-map-profile-id* — An integer from 1 to 64 that defines a unique lag link map profile on this LAG.

### link

**Syntax** **link** *port-id* {**primary**|**secondary**}  
**no primary-link**

**Context** config>lag>link>map>profile

**Description** This command designates one of the configured ports of the LAG to be used on egress as either a primary or secondary link (based on the option selected) by all SAPs/network interfaces that use this LAG link map profile.

The **no** form of this command deletes the link from this LAG link mapping profile. A port must be deleted from all lag link profiles if it is to be deleted from the LAG.

**Default** Links are part of a profile.

**Notes** When a link gets added/deleted, all SAPs/network interfaces that use this link-map-profile may be re-hashed if required.

**Parameters** *port-id* — A physical port Id in the slot/mda/port format that is an existing member of this LAG.

**primary** — Designates one of the configured ports of the LAG to be used on egress as a primary link by SAPs/network interfaces that use this LAG link map profile.

**secondary** — Designates one of the configured ports of the LAG to be used on egress as a secondary link by SAPs/network interfaces that use this LAG link map profile.

## failure-mode

|                    |                                                                                                                                                                                                                                                                                                                                                                                                                                                                                                                                                                                                                                                                                                                                                                                                                                                                                                                             |
|--------------------|-----------------------------------------------------------------------------------------------------------------------------------------------------------------------------------------------------------------------------------------------------------------------------------------------------------------------------------------------------------------------------------------------------------------------------------------------------------------------------------------------------------------------------------------------------------------------------------------------------------------------------------------------------------------------------------------------------------------------------------------------------------------------------------------------------------------------------------------------------------------------------------------------------------------------------|
| <b>Syntax</b>      | <b>failure-mode</b> [ <b>discard</b>   <b>per-link-hash</b> ]<br><b>no failure-mode</b>                                                                                                                                                                                                                                                                                                                                                                                                                                                                                                                                                                                                                                                                                                                                                                                                                                     |
| <b>Context</b>     | config>lag>link>map>profile                                                                                                                                                                                                                                                                                                                                                                                                                                                                                                                                                                                                                                                                                                                                                                                                                                                                                                 |
| <b>Description</b> | This command defines the failure mode for egress traffic of SAPs/network interfaces that use this link-map-profile when neither primary nor secondary links of this profile are available.<br>Options include: <ul style="list-style-type: none"> <li>• <b>discard</b> – egress traffic for SAPs/network interfaces using this link-map-profile is discarded to protect SAP/network interface traffic on other LAG links from impact of re-hashing the affected SAPs/network interfaces</li> <li>• <b>per-link-hash</b> – egress traffic for SAPs/network interfaces using this link-map-profile is rehashed on remaining, available LAG links using per-link-hash algorithm. SAP/network interface QoS configurations dictate what traffic is discarded on any link that may become oversubscribed as result of the re-hash.</li> </ul> <p>The <b>no</b> form of this command restores the default failure-mode value.</p> |
| <b>Default</b>     | <b>failure-mode per-link-hash</b>                                                                                                                                                                                                                                                                                                                                                                                                                                                                                                                                                                                                                                                                                                                                                                                                                                                                                           |

## port

|                    |                                                                                                                                                                                                                                                                                                                                                                                                                                                                                                                                                                                                                                                                               |
|--------------------|-------------------------------------------------------------------------------------------------------------------------------------------------------------------------------------------------------------------------------------------------------------------------------------------------------------------------------------------------------------------------------------------------------------------------------------------------------------------------------------------------------------------------------------------------------------------------------------------------------------------------------------------------------------------------------|
| <b>Syntax</b>      | <b>port</b> <i>port-id</i> [ <i>port-id ...</i> ] [ <b>priority</b> <i>priority</i> ] [ <b>subgroup</b> <i>sub-group-id</i> ]<br><b>no port</b> <i>port-id</i> [ <i>port-id ...</i> ]                                                                                                                                                                                                                                                                                                                                                                                                                                                                                         |
| <b>Context</b>     | config>lag>port                                                                                                                                                                                                                                                                                                                                                                                                                                                                                                                                                                                                                                                               |
| <b>Description</b> | This command adds ports to a Link Aggregation Group (LAG).<br>The port configuration of the first port added to the LAG is used as a basis to compare to subsequently added ports. If a discrepancy is found with a newly added port, that port will not be added to the LAG.<br>Multiple (space separated) ports can be added or removed from the LAG link assuming the maximum of number of ports is not exceeded.<br>Ports that are part of a LAG must be configured with auto-negotiate limited or disabled.<br>The <b>no</b> form of this command removes ports from the LAG.                                                                                            |
| <b>Default</b>     | No ports are defined as members of a LAG.                                                                                                                                                                                                                                                                                                                                                                                                                                                                                                                                                                                                                                     |
| <b>Parameters</b>  | <i>port-id</i> — The port ID configured or displayed in the <i>slot/mda/port</i> format.<br>Note that the maximum number of ports in a LAG depends on platform-type, H/W deployed, and SROS S/W release. Adding a port over the maximum allowed per given router/switch is blocked. Some platforms support double port scale for some port types on LAGs with lag-id in the range of 1-64 inclusive.<br><b>Values</b> slot/mda/port<br><b>priority</b> <i>priority</i> — Port priority used by LACP. The port priority is also used to determine the primary port. The port with the lowest priority is the primary port. In the event of a tie, the smallest port ID becomes |

the primary port.

**Values** 1 — 65535

**subgroup** *sub-group-id* — This parameter identifies a LAG subgroup. When using subgroups in a LAG, they should only be configured on one side of the LAG, not both. Only having one side perform the active/standby selection will guarantee a consistent selection and fast convergence. The active/standby selection will be signalled through LACP to the other side. The hold time should be configured when using subgroups to prevent the LAG going down when switching between active and standby subgroup since momentarily all ports are down in a LAG (break-before-make).

**Values** 1 — 8 identifies a LAG subgroup.

The **auto-iom** subgroup is defined based on the IOM (all ports of the same IOM are assigned to the same subgroup).

The **auto-mds** subgroup is defined based on the MDA. (all ports of the same MDA are assigned to the same subgroup).

## port-threshold

**Syntax** **port-threshold** *value* [**action** {**dynamic-cost** | **down**}  
**no port-threshold**

**Context** config>lag *lag-id*

**Description** This command configures the behavior for the Link Aggregation Group (LAG) if the number of operational links is equal to or below a threshold level.

The **no** form of this command reverts to the default values.

**Default** 0 action down

**Parameters** *value* — The decimal integer threshold number of operational links for the LAG at or below which the configured action will be invoked. If the number of operational links exceeds the port-threshold value, any action taken for being below the threshold value will cease.

**Values** 0 — 63

**action** {**dynamic-cost** | **down**} — Specifies the action to take if the number of active links in the LAG is at or below the threshold value.

When the **dynamic-cost** action is specified, then dynamic costing will be activated. As a result the LAG will remain operationally up with a cost relative to the number of operational links. The link will only be regarded as operationally down when all links in the LAG are down.

When the **down** action is specified, then the LAG will be brought operationally down if the number of operational links is equal to or less than the configured threshold value. The LAG will only be regarded as up once the number of operational links exceeds the configured threshold value.

## selection-criteria

|                    |                                                                                                                                                                                                                                                                                                                                                                                                                                                                                                                                                                                                                                                                                                                                                                                                                                                                                                                                                                                                                                                                                                                                                                                                                                                                                                                                                                                                                                                                                                                                                                                                                                                                                                                                                                                                    |
|--------------------|----------------------------------------------------------------------------------------------------------------------------------------------------------------------------------------------------------------------------------------------------------------------------------------------------------------------------------------------------------------------------------------------------------------------------------------------------------------------------------------------------------------------------------------------------------------------------------------------------------------------------------------------------------------------------------------------------------------------------------------------------------------------------------------------------------------------------------------------------------------------------------------------------------------------------------------------------------------------------------------------------------------------------------------------------------------------------------------------------------------------------------------------------------------------------------------------------------------------------------------------------------------------------------------------------------------------------------------------------------------------------------------------------------------------------------------------------------------------------------------------------------------------------------------------------------------------------------------------------------------------------------------------------------------------------------------------------------------------------------------------------------------------------------------------------|
| <b>Syntax</b>      | <b>selection-criteria</b> { <b>highest-count</b>   <b>highest-weight</b>   <b>best-port</b> } [ <b>slave-to-partner</b> ] [ <b>subgroup-hold-time</b> <i>hold-time</i> ]<br><b>no selection-criteria</b>                                                                                                                                                                                                                                                                                                                                                                                                                                                                                                                                                                                                                                                                                                                                                                                                                                                                                                                                                                                                                                                                                                                                                                                                                                                                                                                                                                                                                                                                                                                                                                                           |
| <b>Context</b>     | config>lag                                                                                                                                                                                                                                                                                                                                                                                                                                                                                                                                                                                                                                                                                                                                                                                                                                                                                                                                                                                                                                                                                                                                                                                                                                                                                                                                                                                                                                                                                                                                                                                                                                                                                                                                                                                         |
| <b>Description</b> | This command specifies which selection criteria should be used to select the active sub-group.                                                                                                                                                                                                                                                                                                                                                                                                                                                                                                                                                                                                                                                                                                                                                                                                                                                                                                                                                                                                                                                                                                                                                                                                                                                                                                                                                                                                                                                                                                                                                                                                                                                                                                     |
| <b>Default</b>     | highest-count                                                                                                                                                                                                                                                                                                                                                                                                                                                                                                                                                                                                                                                                                                                                                                                                                                                                                                                                                                                                                                                                                                                                                                                                                                                                                                                                                                                                                                                                                                                                                                                                                                                                                                                                                                                      |
| <b>Parameters</b>  | <p><b>highest-count</b> — Selects a sub-group with the highest number of eligible members as an active sub-group (not applicable to “power-off” mode of operations).</p> <p><b>highest-weight</b> — Selects a sub-group with the highest aggregate weight as an active subgroup (not applicable to “power-off” mode of operations).</p> <p><b>best-port</b> — Selects a sub-group containing the port with highest priority port as an active subgroup. In case of equal port priorities, the sub-group containing the port with the lowest port-id is chosen.</p> <p><b>slave-to-partner</b> — The <b>slave-to-partner</b> keyword specifies that it, together with the selection criteria, should be used to select the active sub-group. An eligible member is a lag-member link which can potentially become active. This means it is operationally up (not disabled) for use by the remote side. The <b>slave-to-partner</b> parameter can be used to control whether or not this latter condition is taken into account.</p> <p><b>subgroup-hold-time</b> <i>hold-time</i> — Applicable with LACP enabled. Specifies the optional delay timer for switching to a newly selected active sub-group from the existing active sub-group. The timer delay applies only if the existing sub-group remains operationally up.</p> <p><b>Values</b>     <b>not specified</b> – Equivalent to specifying a value of 0. Specifies no delay and to switchover immediately to a new candidate active sub-group.</p> <p><b>Values</b>     0..2000 – Integer specifying the timer value in 10ths of a second.</p> <p><b>Values</b>     <b>infinite</b> – Do not switchover from existing active sub-group if the subgroup remains UP. Manual switchover possible using tools perform lag force command.</p> |

## standby-signalling

|                    |                                                                                                                                                                       |
|--------------------|-----------------------------------------------------------------------------------------------------------------------------------------------------------------------|
| <b>Syntax</b>      | <b>standby-signalling</b> { <b>lACP</b>   <b>power-off</b> }<br><b>no standby-signalling</b>                                                                          |
| <b>Context</b>     | config>lag                                                                                                                                                            |
| <b>Description</b> | This command specifies how the state of a member port is signalled to the remote side when the status corresponding to this member port has the <b>standby</b> value. |

---

## Eth Ring Commands

### eth-ring

|                    |                                                                                                                                                                                                                                                                                                                |
|--------------------|----------------------------------------------------------------------------------------------------------------------------------------------------------------------------------------------------------------------------------------------------------------------------------------------------------------|
| <b>Syntax</b>      | <b>eth-ring</b> <i>ring-id</i><br><b>no eth-ring</b>                                                                                                                                                                                                                                                           |
| <b>Context</b>     | config                                                                                                                                                                                                                                                                                                         |
| <b>Description</b> | This command configures a G.8032 protected Ethernet ring. G.8032 Rings may be configured as major rings with two paths (a&b) or as Sub-Rings with two paths or in the case of an interconnection node a single path.<br>The <b>no</b> form of this command deletes the Ethernet ring specified by the ring-id. |
| <b>Default</b>     | no eth-ring                                                                                                                                                                                                                                                                                                    |
| <b>Parameters</b>  | <i>ring-id</i> — Specifies the ring ID.<br><b>Values</b> 1-128                                                                                                                                                                                                                                                 |

### description

|                    |                                                                                                              |
|--------------------|--------------------------------------------------------------------------------------------------------------|
| <b>Syntax</b>      | <b>description</b> <i>long-description-string</i><br><b>no description</b>                                   |
| <b>Context</b>     | config>eth-ring                                                                                              |
| <b>Description</b> | This command adds a text description for the ring. The no form of this command removes the text description. |
| <b>Default</b>     | “Eth ring”                                                                                                   |
| <b>Parameters</b>  | <i>string</i> — Specifies the text description up to 160 characters in length.                               |

### guard-time

|                    |                                                                                                                                                                                                        |
|--------------------|--------------------------------------------------------------------------------------------------------------------------------------------------------------------------------------------------------|
| <b>Syntax</b>      | <b>guard-time</b> <i>time</i><br><b>no guard-time</b>                                                                                                                                                  |
| <b>Context</b>     | config>eth-ring                                                                                                                                                                                        |
| <b>Description</b> | This command configures the guard time for an Eth-Ring. The guard timer is standard and is configurable from “x”ms to 2 seconds<br>The <b>no</b> form of this command restores the default guard-time. |
| <b>Default</b>     | 5 deciseconds                                                                                                                                                                                          |

**Parameters** *value* — Specifies the guard-time.  
**Values** 1-20 deciseconds

## revert-time

**Syntax** **revert-time** *time*  
**no revert-time**

**Context** config>eth-ring

**Description** This command configures the revert time for an Eth-Ring. It ranges from 60 seconds to 720 second by 1 second intervals.

The no form of this command this command means non-revertive mode and revert time essentially is 0 meaning the revert timers are not set.

**Default** 300 seconds

**Parameters** *value* — Specifies the guard-time.  
**Values** 60 — 720 seconds

## ccm-hold-time

**Syntax** **ccm-hold-time** {**down** *down-timeout* | **up** *up-timeout*}  
**no ccm-hold-time**

**Context** config>eth-ring

This command configures eth-ring dampening timers.

The **no** form of this command set the up and down timer to the default values.

## down

**Syntax** **down** *down-timeout*

**Context** config>eth-ring>ccm-hold-time

This command specifies the timer, which controls the delay between detecting that ring path is down and reporting it to the G.8032 protection module. If a non-zero value is configured, the CPM will wait for the time specified in the value parameter before reporting it to the G.8032 protection module.

**Note:** This parameter applies only to ring path CCM. It does NOT apply to the ring port link state. To damp ring port link state transitions, use hold-time parameter from the physical member port.

**Default** 0 - the fault will be reported immediately to the protection module.

## Eth Ring Commands

**Parameters** *value* — Specifies the down timeout.  
**Values** 0-5000 centiseconds

### up

**Syntax** **up** *up-timeout*

**Context** config>eth-ring>ccm-hold-time

This command specifies the timer, which controls the delay between detecting that ring path is up and reporting it to the G.8032 protection module. If a non-zero value is configured, the CPM will wait for the time specified in the value parameter before reporting it to the G.8032 protection module.

**Note:** This parameter applies only to ring path CCM. It does NOT apply to the member port link state. To damp member port link state transitions, use hold-time parameter from the physical member port.

**Default** 20 deciseconds

**Parameters** *value* — Specifies the hold-time for reporting the recovery.  
**Values** 0-5000 deciseconds

### rpl-node

**Syntax** **rpl-node** [owner | nbr]  
**no rpl-node**

**Context** config>eth-ring

This command configures the G.8032 ring protection link type as owner or neighbor. The no form of the command means this node is not connected to an RPL link. When RPL owner or neighbor is specified either the a or b path must be configured with the RPL end command. An owner is responsible for operation of the rpl link. Configuring the RPL as neighbor is optional (can be left as no rpl-node) but if the command is used the nbr is mandatory. On a Sub-ring without virtual channel it is recommended not to configure the rpl-node nbr since this will block additional RAPS messages on the RPL link. By not configuring this mode RPL messages on sub-rings are processed on RPL links.

The **no** form of this command removes the RPL link.

**Default** no rpl-node

## node-id

**Syntax** **node-id** *mac*  
**no node-id**

**Context** config>eth-ring

This optional command configures the MAC address of the RPL control. The default is to use the chassis MAC for the ring control. This command allows the chassis MAC to be overridden with another MAC address.

The no form of this command removes the RPL link.

**Default** no node-id

**Parameters** *mac* — xx:xx:xx:xx:xx:xx or xx-xx-xx-xx-xx-xx

## sub-ring

**Syntax** **sub-ring** {*virtual-link* | *non-virtual-link*}  
**no sub-ring**

**Context** config>eth-ring>sub-ring

This command additionally specifies this ring-id to be sub-ring as defined in G.80312. By declaring this ring as a sub-ring object, this ring will only have one valid path and the sub-ring will be connected to a major ring or a VPLS instance. The virtual-link parameter declares that a sub-ring is connected to another ring and that control messages can be sent over the attached ring to the other side of the sub-ring. The non-virtual channel parameter declares that a sub-ring may be connected to a another ring or to a VPLS instance but that no control messages from the sub-ring use the attached ring or VPLS instance. The non-virtual channel behavior is standard G.8032 capability.

The no form of this command deletes the sub-ring and its virtual channel associations.

**Default** no sub-ring

**Parameters** *virtual-link* — Specifies the interconnection is to a ring and a virtual link will be used.

*non-virtual-link* — Specifies the interconnection is to a ring or a VPLS instance and a virtual link will not be used.

## compatible-version

**Syntax** **compatible-version** *value*  
**compatible-version**

**Context** config>eth-ring

This command configures eth-ring compatibility version for the G.8032 state machine and messages. The default is version 2 and all 7x50 switches use version 2. If there is a need to interwork with third party devices that only support version 1 this can be set to version 1.

## Eth Ring Commands

The [no] form of this command set the compatibility version to 2.

**Default** 2

**Parameters** *value* — The version 2 of the G.8032 state machine.

## interconnect

**Syntax** **interconnect {ring-id *ring-id* | vpls}**  
**interconnect**

**Context** config>eth-ring>sub-ring>interconnect

This command links the G.8032 sub-ring to a ring instance or to a VPLS instance. The ring instance must be a complete ring with two paths but may itself be a sub-ring or a major ring (declared by its configuration on another node). When the interconnection is to another node, the sub-ring may have a virtual link or a non-virtual-link. When the sub-ring has been configured with a non-virtual link, the sub ring may be alternatively be connected to a VPLS service. This command is only valid on the interconnection node where a single sub-ring port connects to a major ring or terminates on a VPLS service.

The **no** form of this command removes interconnect node.

**Default** no interconnect

**Parameters** *ring-id* — Specifies the ring instance of the connection ring for this sub-ring on this node.

*vpls* — Specifies that the sub- ring is connected to the VPLS instance that contains the sub-ring SAP.

**Values** *ring-id*: 0-128

## propagate-topology-change

**Syntax** **propagate-topology-change**  
**no interconnect**

**Context** config>eth-ring>propagate-topology-change

This command configures the G.8032 sub-ring to propagate topology changes. From the sub-ring to the major ring as specified in the G.8032 interconnection flush logic. This command is only valid on the sub-ring and on the interconnection node. Since this command is only valid on a Sub-ring, a virtual link or non-virtual link must be specified for this command to be configured. The command is blocked on major rings (when both path a and b are specified on a ring).

The **no** form of this command sets propagate to the default

**Default** no propagate-topology-change

## path

|                    |                                                                                                                                                                                                           |
|--------------------|-----------------------------------------------------------------------------------------------------------------------------------------------------------------------------------------------------------|
| <b>Syntax</b>      | <b>path</b> {a   b} <i>portid</i> <b>raps-tag</b> <i>VID</i><br><b>no path</b> {a   b}                                                                                                                    |
| <b>Context</b>     | config>eth-ring                                                                                                                                                                                           |
| <b>Description</b> | This command assigns the ring (major or sub-ring) path to a port and defines the Ring APS tag. Rings typically have two paths a and b.<br><br>The <b>no</b> form of this command removes the path a or b. |
| <b>Default</b>     | no path                                                                                                                                                                                                   |
| <b>Parameters</b>  | <i>raps-tag VID</i> — Specifies the VID.<br><br><b>Values</b> Dot1q: 1-4094<br><b>Values</b> QinQ: 1-4094.1-4094                                                                                          |

## description

|                    |                                                                                                                   |
|--------------------|-------------------------------------------------------------------------------------------------------------------|
| <b>Syntax</b>      | <b>description</b> <i>long-description-string</i><br><b>no description</b>                                        |
| <b>Context</b>     | config>eth-ring>path                                                                                              |
| <b>Description</b> | This command adds a text description for the ring path. The no form of this command removes the text description. |
| <b>Default</b>     | ""                                                                                                                |
| <b>Parameters</b>  | <i>string</i> — Specifies the text description up to 160 characters in length.                                    |

## rpl-end

|                    |                                                                                                                                                                                                                                                                                                       |
|--------------------|-------------------------------------------------------------------------------------------------------------------------------------------------------------------------------------------------------------------------------------------------------------------------------------------------------|
| <b>Syntax</b>      | [no] <b>rpl-end</b>                                                                                                                                                                                                                                                                                   |
| <b>Context</b>     | config>eth-ring                                                                                                                                                                                                                                                                                       |
| <b>Description</b> | This command configures the G.8032 path as a ring protection link end. The ring should be declared as either a RPL owner or RPL neighbor for this command to be allowed. Only path a or path b can be declared an RPL-end.<br><br>The no form of this command sets the rpl-end to default no rpl-end. |
| <b>Default</b>     | no rpl-end                                                                                                                                                                                                                                                                                            |

## Eth Ring Commands

### eth-cfm

- Syntax** **eth-cfm**
- Context** config>eth-ring>path
- Description** This command enables the context to configure ETH-CFM parameters.

### mep

- Syntax** **[no] mep** *mep-id* **domain** *md-index* **association** *ma-index*
- Context** config>eth-ring>path>eth-cfm
- Description** This command provisions an 802.1ag maintenance endpoint (MEP).  
The **no** form of the command deletes the MEP.
- Parameters** *mep-id* — Specifies the maintenance association end point identifier.  
**Values** 1 — 81921
- md-index* — Specifies the maintenance domain (MD) index value.  
**Values** 1 — 4294967295
- ma-index* — Specifies the MA index value.  
**Values** 1 — 4294967295

### ccm-enable

- Syntax** **[no] ccm-enable**
- Context** config>eth-ring>path>eth-cfm>mep
- Description** This command enables the generation of CCM messages.  
The **no** form of the command disables the generation of CCM messages.

### ccm-ltm-priority

- Syntax** **ccm-ltm-priority** *priority*  
**no ccm-ltm-priority**
- Context** config>eth-ring>path>eth-cfm>mep
- Description** This command specifies the priority value for CCMs and LTMs transmitted by the MEP.  
The **no** form of the command removes the priority value from the configuration.
- Default** The highest priority on the bridge-port.

**Parameters** *priority* — Specifies the priority of CCM and LTM messages.

**Values** 0 — 7

## eth-test-enable

**Syntax** [no] **eth-test-enable**

**Context** config>eth-ring>path>eth-cfm>mep

**Description** This command enables eth-test functionality on MEP. For this test to work, operators need to configure ETH-test parameters on both sender and receiver nodes. The ETH-test then can be done using the following OAM commands:

```
oam eth-cfm eth-test mac-address mep mep-id domain md-index association ma-index [priority priority]
[data-length data-length]
```

A check is done for both the provisioning and test to ensure the MEP is an Y.1731 MEP (MEP provisioned with domain format none, association format icc-based). If not, the operation fails. An error message in the CLI and SNMP will indicate the problem.

## test-pattern

**Syntax** **test-pattern** {**all-zeros** | **all-ones**} [**crc-enable**]  
**no test-pattern**

**Context** config>eth-ring>path>eth-cfm>mep>eth-test-enable

**Description** This command configures the test pattern for eth-test frames.  
The **no** form of the command removes the values from the configuration.

**Parameters** **all-zeros** — Specifies to use all zeros in the test pattern.

**all-ones** — Specifies to use all ones in the test pattern.

**crc-enable** — Generates a CRC checksum.

**Default** all-zeros

## bit-error-threshold

**Syntax** **bit-error-threshold** *bit-errors*

**Context** config>eth-ring>path>eth-cfm>mep

**Description** This command specifies the lowest priority defect that is allowed to generate a fault alarm.

**Default** 1

## Eth Ring Commands

**Parameters** *bit-errors* — Specifies the lowest priority defect.

**Values** 0 — 11840

### mac-address

**Syntax** **mac-address** *mac-address*  
**no mac-address**

**Context** config>eth-ring>path>eth-cfm>mep

**Description** This command specifies the MAC address of the MEP.

The **no** form of this command reverts the MAC address of the MEP back to that of the port (if the MEP is on a SAP) or the bridge (if the MEP is on a spoke SDP).

**Parameters** *mac-address* — Specifies the MAC address of the MEP.

**Values** 6-byte unicast mac-address (xx:xx:xx:xx:xx:xx or xx-xx-xx-xx-xx-xx) of the MEP. Using the all zeros address is equivalent to the no form of this command.

### one-way-delay-threshold

**Syntax** **one-way-delay-threshold** *time*

**Context** config>eth-ring>path>eth-cfm>mep

**Description** This command enables one way delay threshold time limit.

**Default** 3 seconds

**Parameters** *priority* — Specifies the value for the threshold.

**Values** 0 — 600

### shutdown

**Syntax** [**no**] **shutdown**

**Context** config>eth-ring>path>eth-cfm>mep

**Description** This command administratively enables or disables the MEP.

The **no** form of this command disables or enables the MEP.

**Default** shutdown

## shutdown

**Syntax** [no] shutdown

**Context** config>eth-ring>path  
config>eth-ring

**Description** This command administratively enables or disables the path.  
The **no** form of this command disables or enables the path.

**Default** shutdown

## shutdown

**Syntax** [no] shutdown

**Context** config>eth-ring

**Description** This command administratively enables/disables the ethernet ring.  
The **no** form of this command disables/enables the path.

**Default** shutdown

---

## ETH-CFM Configuration Commands

### eth-cfm

|                    |                                                                       |
|--------------------|-----------------------------------------------------------------------|
| <b>Syntax</b>      | <b>eth-cfm</b>                                                        |
| <b>Context</b>     | config>port>ethernet<br>config>lag                                    |
| <b>Description</b> | This command enables the context to configure 802.1ag CFM parameters. |

### mep

|                    |                                                                                                                                                                                                                                                                                                                                                                                                                                                                                                                                                    |
|--------------------|----------------------------------------------------------------------------------------------------------------------------------------------------------------------------------------------------------------------------------------------------------------------------------------------------------------------------------------------------------------------------------------------------------------------------------------------------------------------------------------------------------------------------------------------------|
| <b>Syntax</b>      | <b>mep</b> <i>mep-id</i> <b>domain</b> <i>md-index</i> <b>association</b> <i>ma-index</i> [ <b>vlan</b> <i>vlan-id</i> ]<br><b>no mep</b> <i>mep-id</i> <b>domain</b> <i>md-index</i> <b>association</b> <i>ma-index</i> [ <b>vlan</b> <i>vlan-id</i> ]                                                                                                                                                                                                                                                                                            |
| <b>Context</b>     | config>port>ethernet>eth-cfm<br>config>lag>eth-cfm<br>config>router>if>eth-cfm                                                                                                                                                                                                                                                                                                                                                                                                                                                                     |
| <b>Description</b> | This command provisions the maintenance endpoint (MEP).<br>The <b>no</b> form of the command reverts to the default values.                                                                                                                                                                                                                                                                                                                                                                                                                        |
| <b>Parameters</b>  | <p><i>mep-id</i> — Specifies the maintenance association end point identifier.</p> <p><b>Values</b> 1 — 81921</p> <p><i>md-index</i> — Specifies the maintenance domain (MD) index value.</p> <p><b>Values</b> 1 — 4294967295</p> <p><i>ma-index</i> — Specifies the MA index value.</p> <p><b>Values</b> 1 — 4294967295</p> <p><i>vlan-id</i> — Specific to tunnel facility MEPs which means this option is only applicable to the lag&gt;eth-cfm&gt; context. Used to specify the outer vlan id of the tunnel.</p> <p><b>Values</b> 1 — 4094</p> |

## ais-enable

- Syntax** `[no] ais-enable`
- Context** `config>port>ethernet>eth-cfm>mep`  
`config>lag>eth-cfm>mep`
- Description** This command enables the reception of AIS messages.  
 The **no** form of the command reverts to the default values.

## client-meg-level

- Syntax** `client-meg-level [[level [level ...]]`  
`no client-meg-level`
- Context** `config>port>ethernet>eth-cfm>mep>ais-enable`  
`config>lag>eth-cfm> mep>ais-enable`
- Description** This command configures the client maintenance entity group (MEG) level(s) to use for AIS message generation. Up to 7 levels can be provisioned with the restriction that the client MEG level must be higher than the local MEG level. Only the lowest client MEG level will be used for facility MEPs.  
 The **no** form of the command reverts to the default values.
- Parameters** *level* — Specifies the client MEG level.
- |                |       |
|----------------|-------|
| <b>Values</b>  | 1 — 7 |
| <b>Default</b> | 1     |

## interval

- Syntax** `interval {1 | 60}`  
`no interval`
- Context** `config>port>ethernet>eth-cfm>mep>ais-enable`  
`config>lag>eth-cfm> mep>ais-enable`
- Description** This command specifies the transmission interval of AIS messages in seconds.  
 The **no** form of the command reverts to the default values.
- Parameters** `1 | 60` — The transmission interval of AIS messages in seconds.
- |                |   |
|----------------|---|
| <b>Default</b> | 1 |
|----------------|---|

## ETH-CFM Configuration Commands

### priority

**Syntax** **priority** *priority-value*  
**no priority**

**Context** config>port>ethernet>eth-cfm>mep>ais-enable  
config>lag>eth-cfm>mep>ais-enable

**Description** This command specifies the priority of the AIS messages generated by the node.  
The **no** form of the command reverts to the default values.

**Parameters** *priority-value* — Specify the priority value of the AIS messages originated by the node.

**Values** 0 — 7

**Default** 7

### ccm-enable

**Syntax** [**no**] **ccm-enable**

**Context** config>port>ethernet>eth-cfm>mep  
config>lag>eth-cfm>mep

**Description** This command enables the generation of CCM messages.  
The **no** form of the command disables the generation of CCM messages.

### ccm-ltm-priority

**Syntax** **ccm-ltm-priority** *priority*  
**no ccm-ltm-priority**

**Context** config>port>ethernet>eth-cfm>mep>  
config>lag>eth-cfm>mep>  
config>router>if>eth-cfm>mep

**Description** This command specifies the priority of the CCM and LTM messages transmitted by the MEP. Since CCM does not apply to the Router Facility MEP only the LTM priority is of value under that context.  
The **no** form of the command reverts to the default values.

**Default** *priority* — Specifies the priority value

**Values** 0 — 7

**Default** 7

### ccm-padding-size

|                    |                                                                                                                          |
|--------------------|--------------------------------------------------------------------------------------------------------------------------|
| <b>Syntax</b>      | <b>ccm-padding-size</b> <i>ccm-padding</i><br><b>no ccm-padding-size</b>                                                 |
| <b>Context</b>     | config>eth-tunnel>path>eth-cfm>mep                                                                                       |
| <b>Description</b> | This command inserts additional padding in the CCM packets.<br>The <b>no</b> form of the command reverts to the default. |
| <b>Parameters</b>  | <i>ccm-padding</i> — Specifies the additional padding in the CCM packets.<br><b>Values</b> 3 — 1500 octets               |

## ccm-tlv-ignore

|                    |                                                                                                                                                                                                                                                                                         |
|--------------------|-----------------------------------------------------------------------------------------------------------------------------------------------------------------------------------------------------------------------------------------------------------------------------------------|
| <b>Syntax</b>      | <b>ccm-tlv-ignore</b> [ <b>port-status</b> ] [ <b>interface-status</b> ]<br><b>no ccm-tlv-ignore</b>                                                                                                                                                                                    |
| <b>Context</b>     | config>port>ethernet>eth-cfm>mep<br>config>lag>eth-cfm>mep                                                                                                                                                                                                                              |
| <b>Description</b> | This command allows the receiving MEP to ignore the specified TLVs in CCM PDU. Ignored TLVs will be reported as absent and will have no impact on the MEP state machine.<br>The <b>no</b> form of the command causes the receiving MEP will process all recognized TLVs in the CCM PDU. |
| <b>Parameters</b>  | <b>port-status</b> — Ignore the port status TLV on reception.<br><b>interface-status</b> — ignore the interface status TLV on reception.                                                                                                                                                |

## eth-test-enable

|                    |                                                                                                                                                                                                                                                                                                                                                                                                                                         |
|--------------------|-----------------------------------------------------------------------------------------------------------------------------------------------------------------------------------------------------------------------------------------------------------------------------------------------------------------------------------------------------------------------------------------------------------------------------------------|
| <b>Syntax</b>      | [ <b>no</b> ] <b>eth-test-enable</b>                                                                                                                                                                                                                                                                                                                                                                                                    |
| <b>Context</b>     | config>port>ethernet>eth-cfm>mep<br>config>lag>eth-cfm>mep<br>config>router>if>eth-cfm>mep                                                                                                                                                                                                                                                                                                                                              |
| <b>Description</b> | For this test to work, operators need to configure ETH-test parameters on both sender and receiver nodes. The ETH-test then can be done using the following OAM commands:<br><code>oam eth-cfm eth-test <i>mac-address</i> mep <i>mep-id</i> domain <i>md-index</i> association <i>ma-index</i> [priority <i>priority</i>] [data-length <i>data-length</i>]</code><br>The <b>no</b> form of the command disables eth-test capabilities. |

## bit-error-threshold

|               |                                              |
|---------------|----------------------------------------------|
| <b>Syntax</b> | <b>bit-error-threshold</b> <i>bit-errors</i> |
|---------------|----------------------------------------------|

## ETH-CFM Configuration Commands

|                    |                                                                                              |
|--------------------|----------------------------------------------------------------------------------------------|
| <b>Context</b>     | config>eth-ring>path>eth-cfm>mep                                                             |
| <b>Description</b> | This command specifies the lowest priority defect that is allowed to generate a fault alarm. |
| <b>Default</b>     | 1                                                                                            |
| <b>Parameters</b>  | <i>bit-errors</i> — Specifies the lowest priority defect.                                    |
| <b>Values</b>      | 0 — 11840                                                                                    |

### test-pattern

|                    |                                                                                                                                                                                                                      |
|--------------------|----------------------------------------------------------------------------------------------------------------------------------------------------------------------------------------------------------------------|
| <b>Syntax</b>      | <b>test-pattern</b> { <b>all-zeros</b>   <b>all-ones</b> } [ <b>crc-enable</b> ]<br><b>no test-pattern</b>                                                                                                           |
| <b>Context</b>     | config>port>ethernet>eth-cfm>mep>eth-test<br>config>lag>eth-cfm>mep>eth-test<br>config>router>if>eth-cfm>mep>eth-test                                                                                                |
| <b>Description</b> | This command specifies the test pattern of the ETH-TEST frames. This does not have to be configured the same on the sender and the receiver.<br><br>The <b>no</b> form of the command reverts to the default values. |
| <b>Parameters</b>  | <b>all-zeros</b> — Specifies to use all zeros in the test pattern.<br><b>all-ones</b> — Specifies to use all ones in the test pattern.<br><b>crc-enable</b> — Generates a CRC checksum.                              |
| <b>Default</b>     | all-zeros                                                                                                                                                                                                            |

### low-priority-defect

|                    |                                                                                                                                                                                                                                                                                                                                                                            |        |                                                                    |               |                                                              |            |                                                |         |                                 |
|--------------------|----------------------------------------------------------------------------------------------------------------------------------------------------------------------------------------------------------------------------------------------------------------------------------------------------------------------------------------------------------------------------|--------|--------------------------------------------------------------------|---------------|--------------------------------------------------------------|------------|------------------------------------------------|---------|---------------------------------|
| <b>Syntax</b>      | <b>low-priority-defect</b> { <b>allDef</b>   <b>macRemErrXcon</b>   <b>remErrXcon</b>   <b>errXcon</b>   <b>xcon</b>   <b>noXcon</b> }                                                                                                                                                                                                                                     |        |                                                                    |               |                                                              |            |                                                |         |                                 |
| <b>Context</b>     | config>port>ethernet>eth-cfm>mep>eth-test<br>config>lag>eth-cfm>mep>eth-test                                                                                                                                                                                                                                                                                               |        |                                                                    |               |                                                              |            |                                                |         |                                 |
| <b>Description</b> | This command specifies the lowest priority defect that is allowed to generate a fault alarm. This setting is also used to determine the fault state of the MEP which, well enabled to do so, causes a network reaction.                                                                                                                                                    |        |                                                                    |               |                                                              |            |                                                |         |                                 |
| <b>Default</b>     | macRemErrXcon                                                                                                                                                                                                                                                                                                                                                              |        |                                                                    |               |                                                              |            |                                                |         |                                 |
| <b>Values</b>      | <table><tr><td>allDef</td><td>DefRDICCM, DefMACstatus, DefRemoteCCM, DefErrorCCM, and DefXconCCM</td></tr><tr><td>macRemErrXcon</td><td>Only DefMACstatus, DefRemoteCCM, DefErrorCCM, and DefXconCCM</td></tr><tr><td>remErrXcon</td><td>Only DefRemoteCCM, DefErrorCCM, and DefXconCCM</td></tr><tr><td>errXcon</td><td>Only DefErrorCCM and DefXconCCM</td></tr></table> | allDef | DefRDICCM, DefMACstatus, DefRemoteCCM, DefErrorCCM, and DefXconCCM | macRemErrXcon | Only DefMACstatus, DefRemoteCCM, DefErrorCCM, and DefXconCCM | remErrXcon | Only DefRemoteCCM, DefErrorCCM, and DefXconCCM | errXcon | Only DefErrorCCM and DefXconCCM |
| allDef             | DefRDICCM, DefMACstatus, DefRemoteCCM, DefErrorCCM, and DefXconCCM                                                                                                                                                                                                                                                                                                         |        |                                                                    |               |                                                              |            |                                                |         |                                 |
| macRemErrXcon      | Only DefMACstatus, DefRemoteCCM, DefErrorCCM, and DefXconCCM                                                                                                                                                                                                                                                                                                               |        |                                                                    |               |                                                              |            |                                                |         |                                 |
| remErrXcon         | Only DefRemoteCCM, DefErrorCCM, and DefXconCCM                                                                                                                                                                                                                                                                                                                             |        |                                                                    |               |                                                              |            |                                                |         |                                 |
| errXcon            | Only DefErrorCCM and DefXconCCM                                                                                                                                                                                                                                                                                                                                            |        |                                                                    |               |                                                              |            |                                                |         |                                 |

|        |                                                |
|--------|------------------------------------------------|
| xcon   | Only DefXconCCM; or                            |
| noXcon | No defects DefXcon or lower are to be reported |

## mac-address

|                    |                                                                                                                                                                                                                                           |
|--------------------|-------------------------------------------------------------------------------------------------------------------------------------------------------------------------------------------------------------------------------------------|
| <b>Syntax</b>      | <b>mac-address</b> <i>mac-address</i><br><b>no mac-address</b>                                                                                                                                                                            |
| <b>Context</b>     | config>port>ethernet>eth-cfm>mep<br>config>lag>eth-cfm>mep<br>config>router>if>eth-cfm>mep                                                                                                                                                |
| <b>Description</b> | This command specifies the MAC address of the MEP.<br><br>The <b>no</b> form of the command reverts to the MAC address of the MEP back to the default, that of the port, since this is SAP based.                                         |
| <b>Default</b>     | no mac-address                                                                                                                                                                                                                            |
| <b>Parameters</b>  | <i>mac-address</i> — Specifies the MAC address of the MEP.<br><br><b>Values</b> 6-byte unicast mac-address (xx:xx:xx:xx:xx:xx or xx-xx-xx-xx-xx-xx) of the MEP. Using the all zeros address is equivalent to the no form of this command. |

## one-way-delay-threshold

|                    |                                                                                       |
|--------------------|---------------------------------------------------------------------------------------|
| <b>Syntax</b>      | <b>one-way-delay-threshold</b> <i>seconds</i>                                         |
| <b>Context</b>     | config>eth-tunnel>path>eth-cfm>mep                                                    |
| <b>Description</b> | This command enables one way delay threshold time limit.                              |
| <b>Default</b>     | 3 seconds                                                                             |
| <b>Parameters</b>  | <i>priority</i> — Specifies the value for the threshold.<br><br><b>Values</b> 0 — 600 |

## facility-fault

|                    |                                                                                                                                                                                                                                                                                                                                                             |
|--------------------|-------------------------------------------------------------------------------------------------------------------------------------------------------------------------------------------------------------------------------------------------------------------------------------------------------------------------------------------------------------|
| <b>Syntax</b>      | <b>[no] facility-fault</b>                                                                                                                                                                                                                                                                                                                                  |
| <b>Context</b>     | config>lag>eth-cfm>mep<br>config>port>ethernet>eth-cfm>mep                                                                                                                                                                                                                                                                                                  |
| <b>Description</b> | Allows the facility MEP to move from alarming only to network actionable function. This means a facility MEP will not merely report the defect conditions but will be able to action based on the transition of the MEP state. Without this command the facility MEP will only monitor and report and conditions of the MEP do not affect related services. |

## ETH-CFM Configuration Commands

**Default** no facility-fault

### tunnel-fault

**Syntax** tunnel-fault {accept | ignore}

**Context** config>service>vpls>eth-cfm  
config>service>vpls>sap>eth-cfm  
config>service>epipe>eth-cfm  
config>service>epipe>sap>eth-cfm  
config>service>ipipe>eth-cfm  
config>service>ipipe>sap>eth-cfm  
config>service>ies>eth-cfm  
config>service>ies>if>sap>eth-cfm  
config>service>ies>sub-if>grp-if>sap>eth-cfm  
config>service>vprn>eth-cfm  
config>service>vprn>if>sap>eth-cfm  
config>service>vprn>sub-if>grp-if>sap>eth-cfm

**Description** Allows the individual service SAPs to react to changes in the tunnel MEP state. When tunnel-fault accept is configured at the service level, the SAP will react according to the service type, Epipe will set the operational flag and VPLS, IES and VPRN SAP operational state will become down on failure or up on clear. This command triggers the OAM mapping functions to mate SAPs and bindings in an Epipe service as well as setting the operational flag. If AIS generation is the requirement for the Epipe services this command is not required. See the **ais-enable** command under the **config>service>epipe>sap>eth-cfm>ais-enable** context for more details. This works in conjunction with the tunnel-fault accept on the individual SAPs. Both must be set to accept to react to the tunnel MEP state. By default the service level command is “ignore” and the SAP level command is “accept”. This means simply changing the service level command to “accept” will enable the feature for all SAPs. This is not required for Epipe services that only wish to generate AIS on failure.

**Parameters** *accept* — Share fate with the facility tunnel MEP  
*ignore* — Do not share fate with the facility tunnel MEP

**Default** ignore (Service Level)  
accept (SAP Level for Epipe and VPLS)

---

## Multi-Chassis Redundancy Commands

### redundancy

**Syntax** `redundancy`

**Context** `config`

**Description** This command allows the user to perform redundancy operations. Associated commands include the following in the **admin>redundancy** context:

**force-switchover** — Forces a switchover to the standby CPM/CFM card.

**now** — Switch to standby CPM/CFM.

**NOTE:** Switching to the standby displays the following message.

```
WARNING: Configuration and/or Boot options may have changed since the last save.
Are you sure you want to switchover (y/n)?
```

**synchronize** — Synchronizes the secondary CPM/CFM.

**Values** `<boot-env/config>` : keywords

Refer to the 7950 SR OS Basic System Configuration Guide.

### synchronize

**Syntax** `synchronize {boot-env | config}`

**Context** `config>redundancy`

**Description** This command performs a synchronization of the standby CPM/CFM's images and/or config files to the active CPM/CFM. Either the **boot-env** or **config** parameter must be specified.

In the **config>redundancy** context, this command performs an automatically triggered standby CPM/CFM synchronization.

When the standby CPM/CFM takes over operation following a failure or reset of the active CPM/CFM, it is important to ensure that the active and standby CPM/CFMs have identical operational parameters. This includes the saved configuration, CPM and IOM images. This includes the saved configuration, CPM and IOM images. This includes the saved configuration and CFM images.

The active CPM/CFM ensures that the active configuration is maintained on the standby CPM/CFM. However, to ensure smooth operation under all circumstances, runtime images and system initialization configurations must also be automatically synchronized between the active and standby CPM/CFM.

If synchronization fails, alarms and log messages that indicate the type of error that caused the failure of the synchronization operation are generated. When the error condition ceases to exist, the alarm is cleared.

Only files stored on the router are synchronized. If a configuration file or image is stored in a location other than on a local compact flash, the file is not synchronized (for example, storing a configuration file on an FTP server).

## Multi-Chassis Redundancy Commands

**Default** enabled

**Parameters** **boot-env** — Synchronizes all files required for the boot process (loader, BOF, images, and configuration files).

**config** — Synchronize only the primary, secondary, and tertiary configuration files.

**Default** config

### bgp-multi-homing

**Syntax** **bgp-multi-homing**

**Context** config>redundancy

**Description** This command configures BGP multi-homing parameters.

### boot-timer

**Syntax** **boot-timer** *seconds*  
**no boot-timer**

**Context** config>redundancy>bgp-mh

**Description** This command specifies how long the service manager waits after a node reboot before running the MH procedures. The boot-timer value should be configured to allow for the BGP sessions to come up and for the NLRI information to be refreshed/exchanged. The boot-timer is activated after the no shutdown command for a MH site executed from configuration. Upon activation, the boot-timer is compared with the system up-time for the node. If the boot timer is higher than the up-time, then the service manager waits for the boot-timer-sys-up-time, then starts the site-activation-timer.

The no form of this command sets the value to 10.

**Default** 10 sec

**Parameters** *seconds* — Specifies the timer, in seconds.

**Values** 1..100

### site-activation-timer

**Syntax** **site-activation-timer** *seconds*  
**no site-activation-timer**

**Context** config>redundancy>bgp-mh

**Description** This command defines the amount of time the service manager will keep the local sites in standby status, waiting for BGP updates from remote PEs before running the DF election algorithm to decide whether the

site should be unblocked. The timer is started when one of the following event occurs only if the site is operationally up:

- Manual site activation using “no shutdown” at site-id level or at member object(s) level (for example, SAP(s) or PW(s))
- Site activation after a failure

The **no** form of this command sets the value to 2.

**Default** 2 seconds

**Parameters** *seconds* — Specifies the timer, in seconds.

**Values** 1..100

## multi-chassis

**Syntax** **multi-chassis**

**Context** config>redundancy

**Description** This command enables the context to configure multi-chassis parameters.

## peer

**Syntax** [**no**] **peer** *ip-address* **create**

**Context** config>redundancy>multi-chassis

**Description** Use this command to configure up to 20 multi-chassis redundancy peers. Note that it is only for mc-lag (20) not for mc-sync (4).

**Parameters** *ip-address* — Specifies the IP address.

**Values**

|               |                                     |
|---------------|-------------------------------------|
| ipv4-address: | a.b.c.d                             |
| ipv6-address: | x:x:x:x:x:x:x (eight 16-bit pieces) |
|               | x:x:x:x:x:d.d.d.d                   |
|               | x: [0 — FFFF]H                      |
|               | d: [0 — 255]D                       |

**create** — Mandatory keyword specifies to create the peer.

## authentication-key

**Syntax** **authentication-key** [*authentication-key* | *hash-key*] [**hash** | **hash2**]  
**no authentication-key**

**Context** config>redundancy>multi-chassis>peer

**Description** This command configures the authentication key used between this node and the multi-chassis peer. The authentication key can be any combination of letters or numbers.

**Parameters**

- authentication-key* — Specifies the authentication key. Allowed values are any string up to 20 characters long composed of printable, 7-bit ASCII characters. If the string contains special characters (#, \$, spaces, etc.), the entire string must be enclosed within double quotes.
- hash-key* — The hash key. The key can be any combination of ASCII characters up to 33 (hash1-key) or 55 (hash2-key) characters in length (encrypted). If spaces are used in the string, enclose the entire string in quotation marks (“ ”).
- hash** — Specifies the key is entered in an encrypted form. If the hash or hash2 parameter is not used, the key is assumed to be in a non-encrypted, clear text form. For security, all keys are stored in encrypted form in the configuration file with the hash or hash2 parameter specified.
- hash2** — Specifies the key is entered in a more complex encrypted form that involves more variables than the key value alone, this means that hash2 encrypted variable cannot be copied and pasted. If the hash or hash2 parameter is not used, the key is assumed to be in a non-encrypted, clear text form. For security, all keys are stored in encrypted form in the configuration file with the hash or hash2 parameter specified.

---

## MC Endpoint Commands

### mc-endpoint

**Syntax** [no] mc-endpoint

**Context** config>redundancy>multi-chassis>peer

**Description** This command specifies that the endpoint is multi-chassis. This value should be the same on both MC-EP peers for the pseudowires that must be part of the same group.

The **no** form of this command removes the endpoint from the MC-EP. Single chassis behavior applies.

### bfd-enable

**Syntax** [no] bfd-enable

**Context** config>redundancy>multi-chassis>peer>mc-ep  
config>router>rsvp  
config>router>bgp  
config>router>bgp>group  
config>router>bgp>group>neighbor  
config>redundancy>multi-chassis>peer>mc-ep

**Description** This command enables the use of bi-directional forwarding (BFD) to control the state of the associated protocol interface. By enabling BFD on a given protocol interface, the state of the protocol interface is tied to the state of the BFD session between the local node and the remote node. The parameters used for the BFD are set via the BFD command under the IP interface.

The **no** form of this command disables BFD.

**Default** no bfd-enable

### boot-timer

**Syntax** boot-timer *interval*  
no boot-timer

**Context** config>redundancy>multi-chassis>peer>mc-ep

**Description** This command configures the boot timer interval. This command applies only when the node reboots. It specifies the time the MC-EP protocol keeps trying to establish a connection before assuming a failure of the remote peer. This is different from the keep-alives mechanism which is used just after the peer-peer communication was established. After this time interval passed all the mc-endpoints configured under services will revert to single chassis behavior, activating the best local PW.

The **no** form of this command sets the interval to default.

## Multi-Chassis Redundancy Commands

**Default** 300

**Parameters** *interval* — Specifies the boot timer interval.

**Values** 1 — 600

### hold-on-neighbor-failure

**Syntax** **hold-on-neighbor-failure** *multiplier*  
**no hold-on-neighbor-failure**

**Context** config>redundancy>multi-chassis>peer>mc-ep

**Description** This command specifies the number of keep-alive intervals that the local node will wait for packets from the MC-EP peer before assuming failure. After this time interval passed the all the mc-endpoints configured under services will revert to single chassis behavior, activating the best local pseudowire.

The **no** form of this command sets the multiplier to default value

**Default** 3

**Parameters** *multiplier* — Specifies the hold time applied on neighbor failure.

**Values** 2 — 25

### keep-alive-interval

**Syntax** **keep-alive-interval** *interval*  
**no keep-alive-interval**

**Context** config>redundancy>multi-chassis>peer>mc-ep

**Description** This command sets the interval at which keep-alive messages are exchanged between two systems participating in MC-EP when bfd is not enabled or is down. These fast keep-alive messages are used to determine remote-node failure and the interval is set in deci-seconds.

The **no** form of this command sets the interval to default value

**Default** 5 (0.5s)

**Parameters** *interval* — The time interval expressed in deci-seconds.

**Values** 5 — 500 (tenths of a second)

## passive-mode

|                    |                                                                                                                                                                                                                                                                                                                                                                                                                                                                                                                                                                                                                                |
|--------------------|--------------------------------------------------------------------------------------------------------------------------------------------------------------------------------------------------------------------------------------------------------------------------------------------------------------------------------------------------------------------------------------------------------------------------------------------------------------------------------------------------------------------------------------------------------------------------------------------------------------------------------|
| <b>Syntax</b>      | <b>[no] passive-mode</b>                                                                                                                                                                                                                                                                                                                                                                                                                                                                                                                                                                                                       |
| <b>Context</b>     | config>redundancy>multi-chassis>peer>mc-ep                                                                                                                                                                                                                                                                                                                                                                                                                                                                                                                                                                                     |
| <b>Description</b> | <p>This command configures the passive mode behavior for the MC-EP protocol. When in passive mode the MC-EP pair will be dormant until two of the pseudowires in a MC-EP will be signaled as active by the remote PEs, being assumed that the remote pair is configured with regular MC-EP. As soon as more than one pseudowire is active, dormant MC-EP pair will activate. It will use the regular exchange to select the best pseudowire between the active ones and it will block the Rx and Tx directions of the other pseudowires.</p> <p>The <b>no</b> form of this command will disable the passive mode behavior.</p> |
| <b>Default</b>     | no passive-mode                                                                                                                                                                                                                                                                                                                                                                                                                                                                                                                                                                                                                |

## system-priority

|                    |                                                                                                                                                                                                                                                                                                                                             |
|--------------------|---------------------------------------------------------------------------------------------------------------------------------------------------------------------------------------------------------------------------------------------------------------------------------------------------------------------------------------------|
| <b>Syntax</b>      | <b>system-priority <i>value</i></b><br><b>no system-priority</b>                                                                                                                                                                                                                                                                            |
| <b>Context</b>     | config>redundancy>multi-chassis>peer>mc-ep                                                                                                                                                                                                                                                                                                  |
| <b>Description</b> | <p>This command allows the operator to set the system priority. The peer configured with the highest value is chosen to be the Master. If system-priority are equal then the one with the lowest system-id (chassis MAC address) is chosen as the Master.</p> <p>The <b>no</b> form of this command sets the system priority to default</p> |
| <b>Default</b>     | 0                                                                                                                                                                                                                                                                                                                                           |
| <b>Parameters</b>  | <i>value</i> — Specifies the priority assigned to the local MC-EP peer.                                                                                                                                                                                                                                                                     |
|                    | <b>Values</b> 1— 255                                                                                                                                                                                                                                                                                                                        |

## MC LAG Commands

### mc-lag

**Syntax** [no] mc-lag

**Context** config>redundancy>multi-chassis>peer>mc-lag

**Description** This command enables the context to configure multi-chassis LAG operations and related parameters. The **no** form of this command administratively disables multi-chassis LAG. MC-LAG can be issued only when mc-lag is shutdown.

### hold-on-neighbor-failure

**Syntax** hold-on-neighbor-failure *multiplier*  
no hold-on-neighbor-failure

**Context** config>redundancy>multi-chassis>peer>mc-lag

**Description** This command specifies the interval that the standby node will wait for packets from the active node before assuming a redundant-neighbor node failure. This delay in switch-over operation is required to accommodate different factors influencing node failure detection rate, such as IGP convergence, or HA switch-over times and to prevent the standby node to take action prematurely. The **no** form of this command sets this parameter to default value.

**Default** 3

**Parameters** *multiplier* — The time interval that the standby node will wait for packets from the active node before assuming a redundant-neighbor node failure.

**Values** 2 — 25

### keep-alive-interval

**Syntax** keep-alive-interval *interval*  
no keep-alive-interval

**Context** config>redundancy>multi-chassis>peer>mc-lag

**Description** This command sets the interval at which keep-alive messages are exchanged between two systems participating in MC-LAG. These keep-alive messages are used to determine remote-node failure and the interval is set in deci-seconds.

The **no** form of this command sets the interval to default value

**Default** 1s (10 hundreds of milliseconds means interval value of 10)

**Parameters** *interval* — The time interval expressed in deci-seconds

**Values** 5 — 500

## lag

**Syntax** **lag** *lag-id* **lacp-key** *admin-key* **system-id** *system-id* [**remote-lag** *remote-lag-id*] **system-priority** *system-priority* **source-bmac-lsb** *use-lacp-key*  
**lag** *lag-id* **lacp-key** *admin-key* **system-id** *system-id* [**remote-lag** *remote-lag-id*] **system-priority** *system-priority* **source-bmac-lsb** *MAC-Lsb*  
**lag** *lag-id* **lacp-key** *admin-key* **system-id** *system-id* [**remote-lag** *remote-lag-id*] **system-priority** *system-priority*  
**lag** *lag-id* [**remote-lag** *remote-lag-id*]  
**no lag** *lag-id*

**Context** config>redundancy>multi-chassis>peer>mc-lag

**Description** This command defines a LAG which is forming a redundant-pair for MC-LAG with a LAG configured on the given peer. The same LAG group can be defined only in the scope of 1 peer. In order MC-LAG to become operational, all parameters (**lacp-key**, **system-id**, **system-priority**) must be configured the same on both nodes of the same redundant pair.

The partner system (the system connected to all links forming MC-LAG) will consider all ports using the same **lacp-key**, **system-id**, **system-priority** as the part of the same LAG. In order to achieve this in MC operation, both redundant-pair nodes have to be configured with the same values. In case of the mismatch, MC-LAG is kept in oper-down status.

Note that the correct CLI command to enable MC LAG for a LAG in **standby-signaling power-off mode** is **lag** *lag-id* [**remote-lag** *remote-lag-id*]. In the CLI help output, the first three forms are used to enable MC LAG for a LAG in LACP mode. MC LAG is disabled (regardless of the mode) for a given LAG with **no lag** *lag-id*.

**Default** none

**Parameters** *lag-id* — The LAG identifier, expressed as a decimal integer. Specifying the *lag-id* allows the mismatch between *lag-id* on redundant-pair. If no **lag-id** is specified it is assumed that neighbor system uses the same *lag-id* as a part of the given MC-LAG. If no matching MC-LAG group can be found between neighbor systems, the individual LAGs will operate as usual (no MC-LAG operation is established.).

**Values** 1 — 200

**lacp-key** *admin-key* — Specifies a 16 bit key that needs to be configured in the same manner on both sides of the MC-LAG in order for the MC-LAG to come up.

**Values** 1 — 65535

**system-id** *system-id* — Specifies a 6 byte value expressed in the same notation as MAC address

**Values** xx:xx:xx:xx:xx:xx - xx [00..FF]

**remote-lag** *lag-id* — Specifies the LAG ID on the remote system.

**Values** 1 — 200

**system-priority** *system-priority* — Specifies the system priority to be used in the context of the MC-LAG.

## Multi-Chassis Redundancy Commands

The partner system will consider all ports using the same **lacp-key**, **system-id**, and **system-priority** as part of the same LAG.

**Values** 1 — 65535

**source-bmac-lsb** *MAC-Lsb* — Configures the last 16 bit of the MAC address to be used for all traffic ingressing the MC-LAG link(s) or if use-lacp-key option is used, it will only copy the value of lacp-key (redundancy multi-chassis mc-lag lag lacp-key admin-key). The command will fail if the *value* is the same with any of the following configured attributes:

- source-bmac-lsb assigned to other MC-LAG ports
- lsb 16 bits value for the source-bmac configured at chassis or BVPLS level

The first 32 bits will be copied from the source BMAC of the BVPLS associated with the IVPLS for a specific IVPLS SAP mapped to the MC-LAG. The BVPLS source BMAC can be provisioned for each BVPLS or can be inherited from the chassis PBB configuration.

**Values** 1 — 65535 or xx-xx or xx:xx

### source-address

**Syntax** **source-address** *ip-address*  
**no source-address**

**Context** config>redundancy>multi-chassis>peer

**Description** This command specifies the source address used to communicate with the multi-chassis peer.

**Parameters** *ip-address* — Specifies the source address used to communicate with the multi-chassis peer.

### sync

**Syntax** [**no**] **sync**

**Context** config>redundancy>multi-chassis>peer

**Description** This command enables the context to configure synchronization parameters.

### igmp

**Syntax** [**no**] **igmp**

**Context** config>redundancy>multi-chassis>peer>sync

**Description** This command specifies whether IGMP protocol information should be synchronized with the multi-chassis peer.

**Default** no igmp

## igmp-snooping

|                    |                                                                                                              |
|--------------------|--------------------------------------------------------------------------------------------------------------|
| <b>Syntax</b>      | <b>[no] igmp-snooping</b>                                                                                    |
| <b>Context</b>     | config>redundancy>multi-chassis>peer>sync                                                                    |
| <b>Description</b> | This command specifies whether IGMP snooping information should be synchronized with the multi-chassis peer. |
| <b>Default</b>     | no igmp-snooping                                                                                             |

## mld

|                    |                                                                                                             |
|--------------------|-------------------------------------------------------------------------------------------------------------|
| <b>Syntax</b>      | <b>[no] mld</b>                                                                                             |
| <b>Context</b>     | config>redundancy>multi-chassis>peer>sync                                                                   |
| <b>Description</b> | This command specifies whether MLD protocol information should be synchronized with the multi-chassis peer. |
| <b>Default</b>     | no mld                                                                                                      |

## mld-snooping

|                    |                                                                                                             |
|--------------------|-------------------------------------------------------------------------------------------------------------|
| <b>Syntax</b>      | <b>[no] mld-snooping</b>                                                                                    |
| <b>Context</b>     | config>redundancy>multi-chassis>peer>sync                                                                   |
| <b>Description</b> | This command specifies whether MLD snooping information should be synchronized with the multi-chassis peer. |
| <b>Default</b>     | no mld-snooping                                                                                             |

## port

|                    |                                                                                                                                                                                                                                                                                                                        |
|--------------------|------------------------------------------------------------------------------------------------------------------------------------------------------------------------------------------------------------------------------------------------------------------------------------------------------------------------|
| <b>Syntax</b>      | <b>port</b> [ <i>port-id</i>   <i>lag-id</i> ] [ <b>sync-tag</b> <i>sync-tag</i> ]<br><b>no port</b> [ <i>port-id</i>   <i>lag-id</i> ]                                                                                                                                                                                |
| <b>Context</b>     | config>redundancy>multi-chassis>peer>sync                                                                                                                                                                                                                                                                              |
| <b>Description</b> | This command specifies the port to be synchronized with the multi-chassis peer and a synchronization tag to be used while synchronizing this port with the multi-chassis peer.                                                                                                                                         |
| <b>Parameters</b>  | <i>port-id</i> — Specifies the port to be synchronized with the multi-chassis peer.<br><i>lag-id</i> — Specifies the LAG ID to be synchronized with the multi-chassis peer.<br><b>sync-tag</b> <i>sync-tag</i> — Specifies a synchronization tag to be used while synchronizing this port with the multi-chassis peer. |

## Multi-Chassis Redundancy Commands

### range

**Syntax** **range** *encap-range* **sync-tag** *sync-tag*  
**no range** *encap-range*

**Context** config>redundancy>multi-chassis>peer>sync>port

**Description** This command configures a range of encapsulation values.

**Parameters** **Values** *encap-range*

Specifies a range of encapsulation values on a port to be synchronized with a multi-chassis peer.

**Values** Dot1Q *start-vlan-end-vlan*  
QinQ *Q1.start-vlan-Q1.end-vlan*

**sync-tag** *sync-tag* — Specifies a synchronization tag up to 32 characters in length to be used while synchronizing this encapsulation value range with the multi-chassis peer.

---

## Multi-Chassis Ring Commands

### mc-ring

**Syntax** [no] mc-ring

**Context** config>redundancy>mc>peer  
config>redundancy>multi-chassis>peer>sync

**Description** This command enables the context to configure the multi-chassis ring parameters.

### ring

**Syntax** ring sync-tag [create]  
no ring sync-tag

**Context** config>redundancy>mc>peer>mcr

**Description** This command configures a multi-chassis ring.

**Parameters**      **Values**      sync-tag

Specifies a synchronization tag to be used while synchronizing this port with the multi-chassis peer.

**create** — Keyword used to create the multi-chassis peer ring instance. The **create** keyword requirement can be enabled/disabled in the **environment>create** context.

### in-band-control-path

**Syntax** in-band-control-path

**Context** config>redundancy>mc>peer>mcr>ring

**Description** This command enables the context to configure multi-chassis ring inband control path parameters.

## Multi-Chassis Redundancy Commands

### dst-ip

|                    |                                                                                                                                                                |
|--------------------|----------------------------------------------------------------------------------------------------------------------------------------------------------------|
| <b>Syntax</b>      | <b>dst-ip</b> <i>ip-address</i><br><b>no dst-ip</b>                                                                                                            |
| <b>Context</b>     | config>redundancy>mc>peer>mcr>ring>in-band-control-path<br>config>redundancy>mc>peer>mcr>node>cv                                                               |
| <b>Description</b> | This command specifies the destination IP address used in the inband control connection. If the address is not configured, the ring cannot become operational. |
| <b>Parameters</b>  | <i>ip-address</i> — Specifies the destination IP address.                                                                                                      |

### interface

|                    |                                                                                                                                                                |
|--------------------|----------------------------------------------------------------------------------------------------------------------------------------------------------------|
| <b>Syntax</b>      | <b>interface</b> <i>ip-int-name</i><br><b>no interface</b>                                                                                                     |
| <b>Context</b>     | config>redundancy>mc>peer>mcr>ring>in-band-control-path                                                                                                        |
| <b>Description</b> | This command specifies the name of the IP interface used for the inband control connection. If the name is not configured, the ring cannot become operational. |

### service-id

|                    |                                                                                                                                                                                                                                                                                                                        |
|--------------------|------------------------------------------------------------------------------------------------------------------------------------------------------------------------------------------------------------------------------------------------------------------------------------------------------------------------|
| <b>Syntax</b>      | <b>service-id</b> <i>service-id</i><br><b>no service-id</b>                                                                                                                                                                                                                                                            |
| <b>Context</b>     | config>redundancy>mc>peer>mcr>ring>ibc<br>config>redundancy>mc>peer>mcr>node>cv                                                                                                                                                                                                                                        |
| <b>Description</b> | This command specifies the service ID if the interface used for the inband control connection belongs to a VPRN service. If not specified, the <i>service-id</i> is zero and the interface must belong to the Base router.<br><br>The <b>no</b> form of the command removes the service-id from the IBC configuration. |
| <b>Parameters</b>  | <i>service-id</i> — Specifies the service ID if the interface.<br><br><b>Values</b> <i>service-id:</i> 1 — 2147483647                                                                                                                                                                                                  |

### path-b

|                    |                                                                                                                                                                |
|--------------------|----------------------------------------------------------------------------------------------------------------------------------------------------------------|
| <b>Syntax</b>      | <b>[no] path-b</b>                                                                                                                                             |
| <b>Context</b>     | config>redundancy>mc>peer>mcr>ring                                                                                                                             |
| <b>Description</b> | This command specifies the set of upper-VLAN IDs associated with the SAPs that belong to path B with respect to load-sharing. All other SAPs belong to path A. |

**Default** If not specified, the default is an empty set.

## range

**Syntax** **[no] range** *vlan-range*

**Context** config>redundancy>mc>peer>mcr>ring>path-b  
config>redundancy>mc>peer>mcr>ring>path-excl

**Description** This command configures a MCR b-path VLAN range.

**Parameters** *vlan-range* — Specifies the VLAN range.

**Values** [0 — 4094] — [0 — 4094]

## path-excl

**Syntax** **[no] path-excl**

**Context** config>redundancy>mc>peer>mcr>ring

**Description** This command specifies the set of upper-VLAN IDs associated with the SAPs that are to be excluded from control by the multi-chassis ring.

**Default** If not specified, the default is an empty set.

## ring-node

**Syntax** **ring-node** *ring-node-name* [**create**]  
**no ring-node** *ring-node-name*

**Context** config>redundancy>mc>peer>mcr>ring

**Description** This command specifies the unique name of a multi-chassis ring access node.

**Parameters** *ring-node-name* — Specifies the unique name of a multi-chassis ring access node.

**create** — Keyword used to create the ring node instance. The **create** keyword requirement can be enabled/disabled in the **environment>create** context.

## connectivity-verify

- Syntax** **connectivity-verify**
- Context** config>redundancy>mc>peer>mcr>ring>ring-node
- Description** This command enables the context to configure node connectivity check parameters.

## interval

- Syntax** **interval** *interval*  
**no interval**
- Context** config>redundancy>mc>peer>mcr>node>cv
- Description** This command specifies the polling interval of the ring-node connectivity verification of this ring node.
- Default** 5
- Parameters** *interval* — Specifies the polling interval, in minutes.
- Values** 1 — 6000

## service-id

- Syntax** **service-id** *service-id*  
**no service-id**
- Context** config>redundancy>mc>peer>mcr>node>cv
- Description** This command specifies the service ID of the SAP used for the ring-node connectivity verification of this ring node.
- Default** no service-id
- Parameters** *service-id* — Specifies the service ID of the SAP.
- Values** 1 — 2147483647
- Values** *service-id:* 1 — 2147483647

## src-ip

|                    |                                                                                                                 |
|--------------------|-----------------------------------------------------------------------------------------------------------------|
| <b>Syntax</b>      | <b>src-ip</b> <i>ip-address</i><br><b>no src-ip</b>                                                             |
| <b>Context</b>     | config>redundancy>mc>peer>mcr>node>cv                                                                           |
| <b>Description</b> | This command specifies the source IP address used in the ring-node connectivity verification of this ring node. |
| <b>Default</b>     | no src-ip                                                                                                       |
| <b>Parameters</b>  | <i>ip-address</i> — Specifies the source IP address.                                                            |

## src-mac

|                    |                                                                                                                                                                                                                                                                |
|--------------------|----------------------------------------------------------------------------------------------------------------------------------------------------------------------------------------------------------------------------------------------------------------|
| <b>Syntax</b>      | <b>src-mac</b> <i>ieee-address</i><br><b>no src-mac</b>                                                                                                                                                                                                        |
| <b>Context</b>     | config>redundancy>mc>peer>mcr>node>cv                                                                                                                                                                                                                          |
| <b>Description</b> | This command specifies the source MAC address used for the Ring-Node Connectivity Verification of this ring node.<br><br>A value of all zeroes (000000000000 H (0:0:0:0:0:0)) specifies that the MAC address of the system management processor (CPM) is used. |
| <b>Default</b>     | no src-mac                                                                                                                                                                                                                                                     |
| <b>Parameters</b>  | <i>ieee-address</i> — Specifies the source MAC address.                                                                                                                                                                                                        |

## vlan

|                    |                                                                                                                                                                                                                                                                                                        |             |       |      |  |      |             |  |      |          |  |       |          |  |       |          |
|--------------------|--------------------------------------------------------------------------------------------------------------------------------------------------------------------------------------------------------------------------------------------------------------------------------------------------------|-------------|-------|------|--|------|-------------|--|------|----------|--|-------|----------|--|-------|----------|
| <b>Syntax</b>      | <b>vlan</b> [ <i>vlan-encap</i> ]<br><b>no vlan</b>                                                                                                                                                                                                                                                    |             |       |      |  |      |             |  |      |          |  |       |          |  |       |          |
| <b>Context</b>     | config>redundancy>mc>peer>mcr>node>cv                                                                                                                                                                                                                                                                  |             |       |      |  |      |             |  |      |          |  |       |          |  |       |          |
| <b>Description</b> | This command specifies the VLAN tag used for the Ring-node Connectivity Verification of this ring node. It is only meaningful if the value of service ID is not zero. A zero value means that no VLAN tag is configured.                                                                               |             |       |      |  |      |             |  |      |          |  |       |          |  |       |          |
| <b>Default</b>     | no vlan                                                                                                                                                                                                                                                                                                |             |       |      |  |      |             |  |      |          |  |       |          |  |       |          |
| <b>Parameters</b>  | <i>vlan-encap</i> — Specifies the VLAN tag.                                                                                                                                                                                                                                                            |             |       |      |  |      |             |  |      |          |  |       |          |  |       |          |
| <b>Values</b>      | <table> <tr> <td>vlan-encap:</td> <td>dot1q</td> <td>qtag</td> </tr> <tr> <td></td> <td>qinq</td> <td>qtag1.qtag2</td> </tr> <tr> <td></td> <td>qtag</td> <td>0 — 4094</td> </tr> <tr> <td></td> <td>qtag1</td> <td>1 — 4094</td> </tr> <tr> <td></td> <td>qtag2</td> <td>0 — 4094</td> </tr> </table> | vlan-encap: | dot1q | qtag |  | qinq | qtag1.qtag2 |  | qtag | 0 — 4094 |  | qtag1 | 1 — 4094 |  | qtag2 | 0 — 4094 |
| vlan-encap:        | dot1q                                                                                                                                                                                                                                                                                                  | qtag        |       |      |  |      |             |  |      |          |  |       |          |  |       |          |
|                    | qinq                                                                                                                                                                                                                                                                                                   | qtag1.qtag2 |       |      |  |      |             |  |      |          |  |       |          |  |       |          |
|                    | qtag                                                                                                                                                                                                                                                                                                   | 0 — 4094    |       |      |  |      |             |  |      |          |  |       |          |  |       |          |
|                    | qtag1                                                                                                                                                                                                                                                                                                  | 1 — 4094    |       |      |  |      |             |  |      |          |  |       |          |  |       |          |
|                    | qtag2                                                                                                                                                                                                                                                                                                  | 0 — 4094    |       |      |  |      |             |  |      |          |  |       |          |  |       |          |

---

## Forwarding Plane Commands

### fp

**Syntax** `fp [fp-number]`

**Context** `config>card`

**Description** This command enables the context to configure multicast path management commands for IOM-3 ingress multicast management. Ingress multicast management manages multicast switch fabric paths which are forwarding plane specific. On IOM-1 and IOM-2, each MDA has a dedicated forwarding plane and so have dedicated multicast paths to the switch fabric allowing the multicast management to be defined per MDA. IOM-3 has a single forwarding plane shared by two MDAs. The fp node simplifies ingress multicast management on IOM-3.

While IOM-3 only has a single forwarding plane. In future releases, to accommodate multiple forwarding planes, each forwarding plane will be assigned a value. The default forwarding plane is 1. When entering the fp node, if the forwarding plane number is omitted, the system will assume forwarding plane number 1.

**Parameters** *fp-number* — The fp-number parameter is optional following the **fp** command. If omitted, the system assumes forwarding plane number 1.

**Values** 1

**Default** 1

### dist-cpu-protection

**Syntax** `dist-cpu-protection policy-name`  
`no dist-cpu-protection`

**Context** `config>card>fp`

**Description** This command specifies the protocol name to be monitored by Distributed CPU Protection Policy.

### egress

**Syntax** `egress`

**Context** `config>card>fp`

**Description** This command enables the egress **fp** node that contains the multicast path management configuration commands for ingress multicast management.

## wred-queue-control

**Syntax** `wred-queue-control`

**Context** `config>card>fp>egress`

**Description** This command enables the context to configure the aggregate WRED queue parameters for all WRED queues on an egress forwarding plane.

## buffer-allocation

**Syntax** `buffer-allocation min percentage max percentage`  
`no buffer-allocation`

**Context** `config>card>fp>egress>max-wred-control`

**Description** The `buffer-allocation` command defines the amount of buffers that will be set aside for WRED queue buffer pools. **Note** that the `min percentage` and `max percentage` parameters must be set to the same value. The XMA protects against cross application buffer starvation by implementing a hierarchy of buffer pools. At the top of the hierarchy are mega-pools. Mega-pools are used to manage buffers at a system application level. Two mega-pools are currently used by the system. The first (default) mega-pool services all non-WRED type queues and when WRED queues are not enabled will contain all available forwarding plane queue buffers. When WRED queuing is enabled, the second mega-pool (the WRED mega-pool) is given buffers from the default mega-pool based on the `buffer-allocation` command and the size if further fine-tuned by the forwarding class oversubscription factors.

The mega-pools provide buffers to the second tier buffer pools. The default mega-pool services all default pools and explicitly created named pools. As the name implies, the WRED mega-pool services all the WRED buffer pools created for the WRED queues. The WRED mega-pool allows each WRED queue pool to be configured to an appropriate size while allowing the sum of the WRED queue pool sizes to oversubscribe the total amount set aside for WRED queue buffering without affecting the queues using the default or named pools. Further oversubscription controls are described within the `resv-cbs` command later in this document.

The WRED mega-pool is allowed to expand between the min and max percent of total forwarding plane buffers based on the sum of the WRED queue sizes and the WRED oversubscription factors. As the WRED mega-pool grows, the number of buffers available to the default mega-pool will shrink. If the WRED mega-pool shrinks, the default mega-pool will grow accordingly. When min and max are defined as the same value, the WRED mega-pool size will not fluctuate and the oversubscription factors will have no effect.

No buffers are allocated to the WRED mega-pool until the `wred-queue-control shutdown` command is set to no shutdown. When the shutdown command is executed, all buffers allocated to the WRED mega-pool are returned to the default mega-pool and all WRED queues are returned either to their default buffer pool or their specified named buffer pool.

## FC MBS Oversubscription Factors and WRED Mega-Pool Sizing

Each WRED queue in a SAP egress QoS policy is created on an egress XMA when the policy is applied to an egress SAP on the XMA and at least one forwarding class is mapped to the queue. For WRED queue buffer management purposes, each forwarding class is configured with an MBS oversubscription factor (OSF) on the IOM using the `osf` command. The MBS oversubscription factor is used by the system as a provision-

## Multi-Chassis Redundancy Commands

ing parameter that defines the acceptable level of oversubscription between the sum of the maximum buffer sizes (mbs) of the WRED queues for a given class and the number of buffers for that class in the WRED mega-pool. Since multiple forwarding classes may be mapped to the same queue, the oversubscription factor associated with the highest forwarding class mapped is used for dynamically sizing the WRED mega-pool.

As an example, when a WRED queue is configured with the following attributes:

- MBS equal to 10Kbytes
- AF as the highest forwarding class mapped

And the forwarding plane on the XMA is configured with the following WRED limits:

- Current WRED mega-pool is sized at 500Kbytes
- AF MBS oversubscription factor is 2 (2:1)

The system will increase the WRED mega-pool size to 505Kbytes (increase of 10Kbytes/2) as long as the maximum buffer allocation percentage equates to a value equal to or greater than 505Kbytes. (If not, the WRED mega-pool will be capped at the maximum level.)

The **no** form of the command immediately restores the default min and max percentage values for sizing the WRED mega-pool.

**Parameters** **min percent-of-total** — This required keyword defines the minimum percentage of total queue buffers that will be applied to the WRED mega-pool. The value given for percent-of-total must be less than or equal to the value given for the **max percent-of-total**. Percentages are defined with an accuracy of hundredths of a percent in the nn.nn format (15.65 = 15.65%).

**Values** 0.00 — 99.99

**Default** 25.00

**max percent-of-total** — This required keyword defines the maximum percentage of total queue buffers that may be applied to the WRED mega-pool. The value given for percent-of-total must be greater than or equal to the value given for the **min percent-of-total**. Percentages are defined with an accuracy of hundredths of a percent in the nn.nn format (15.65 = 15.65%).

**Values** 0.01 — 99.99

**Default** 25.00

### resv-cbs

**Syntax** **resv-cbs min percentage max percentage**  
**no resv-cbs**

**Context** config>card>fp>egress>max-wred-control

**Description** This command defines the amount of buffers within the WRED mega-pool that will be set aside for WRED queues operating within their configured CBS thresholds. **Note** that the **min percentage** and **max percentage** parameters must be set to the same value. The XMA protects against WRED queue buffer starvation by setting aside a portion of the buffers within the WRED mega-pool. The WRED queue CBS threshold defines when a WRED queue requests buffers from reserved portion of the WRED mega-pool and when it starts requesting buffers from the shared portion of the mega-pool. With proper oversubscription provisioning, this prevents a seldom active queue from being denied a buffer from the mega-pool when the shared portion of

the mega-pool is congested. Further control over shared congestion is defined later in this document under the `slope-policy` command.

The WRED mega-slope reserve CBS size is controlled in the same manner as the overall sizing of the WRED mega-pool. A `min` and `max` parameter is provided to scope the range that the reserved portion based on percentages of the WRED mega-pool current size. Forwarding class `cbs-factor` settings are used in the same way as the `mbs-factor` parameters to move the actual reserved size between the minimum and maximum thresholds according to appropriate oversubscription factors that are applied to the sum of the WRED queue CBS values.

When `min` and `max` are defined as the same value, the WRED mega-pool size will not fluctuate and the oversubscription factors will have no effect.

## FC CBS Oversubscription Factors and WRED CBS Reserve Sizing

Each WRED queue in a SAP egress QoS policy is created on an egress XMA when the policy is applied to an egress SAP on the XMA and at least one forwarding class is mapped to the queue. For WRED queue CBS buffer management purposes, each forwarding class is configured with a CBS oversubscription factor (OSF) on the IOM using the `osf` command. The CBS oversubscription factor is used by the system as a provisioning parameter that defines the acceptable level of oversubscription between the sum of the committed buffer sizes (CBS) of the WRED queues for a given class and the number of buffers for that class that should be placed in the WRED mega-pool CBS reserve. Since multiple forwarding classes may be mapped to the same queue, the oversubscription factor associated with the highest forwarding class mapped is used for dynamically sizing the WRED mega-pool CBS reserve.

As an example, when a WRED queue is configured with the following attributes:

- CBS equal to 6Kbytes
- AF as the highest forwarding class mapped

And the forwarding plane on the XMA is configured with the following WRED limits:

- Current WRED mega-pool CBS reserve is sized at 100Kbytes
- AF CBS oversubscription factor is 2 (2:1)

The system will increase the WRED mega-pool CBS reserve size to 103Kbytes (increase of 6Kbytes/2) as long as the maximum buffer allocation percentage for `resv-cbs` equates to a value equal to or greater than 103Kbytes. (If not, the WRED mega-pool CBS reserve will be capped at the maximum level.)

The `no` form of the command immediately restores the default `min` and `max` percentage values for sizing the WRED mega-pool CBS reserve.

**Parameters** **min** *percent-of-total* — This required keyword defines the minimum percentage of the WRED mega-pool buffers that will be applied to the CBS reserve. The value given for `percent-of-wred` must be less than or equal to the value given for the `max percent-of-wred`. Percentages are defined with an accuracy of hundredths of a percent in the `nn.nn` format (15.65 = 15.65%).

**Values** 0.00 — 99.99

**Default** 25.00

**max** *percent-of-total* — This required keyword defines the maximum percentage of the WRED mega-pool buffers that may be applied to the CBS reserve. The value given for `percent-of-wred` must be greater than or equal to the value given for the `min percent-of-wred`. Percentages are defined with an accuracy

## Multi-Chassis Redundancy Commands

of hundredths of a percent in the nn.nn format (15.65 = 15.65%).

**Values** 0.01 — 99.99

**Default** 25.00

### slope-policy

**Syntax** **slope-policy** *slope-policy-name*  
**no slope-policy**

**Context** config>card>fp>egress>max-wred-control

**Description** This command configures WRED slopes within the WRED mega-pool. The WRED slopes in the WRED mega-pool are used when WRED queues are requesting buffers from the mega-pool while they are over their CBS threshold. Once over the CBS threshold, the WRED queue stops receiving buffers from the CBS reserve in the mega-pool and starts competing for buffers in the shared portion of the mega-pool. If the packet resulting in the buffer request is in-profile, the packet will be associated with the high priority slope. Out-of-profile packets are associated with the low priority slope. While the queue is within its CBS threshold, the slopes are ignored.

Within the defined slope-policy, each slope is enabled or disabled (no shutdown or shutdown) and each slope's geometry is defined as percentages of shared portion depth.

The slope-policy also defines the time average factor (TAF) value that is used to determine how the pool's weighted average depth is calculated. The higher the factor, the slower the average depth tracks the actual pool depth.

The **no** form of the command restores the default slope policy to the WRED mega-pool.

**Parameters** *slope-policy-name* — This required parameter specifies which slope policy the system should apply to the WRED mega-pool. When slope-policy is not executed, the WRED mega-pool will use the default slope policy. The defined slope policy must already exist or the command will fail.

**Default** When not defined, the default slope policy is used

### hi-bw-mcast-src

**Syntax** **hi-bw-mcast-src** [**alarm**] [**group** *group-id*]  
**no hi-bw-mcast-src**

**Context** config>card>fp

**Description** This command designates the forwarding plane as a high-bandwidth IP multicast source, expecting the ingress traffic to include high-bandwidth IP multicast traffic. When configured, the system attempts to allocate a dedicated multicast switch fabric plane (MSFP) to the forwarding plane. If a group is specified, all FPs in the group will share the same MSFP. If the alarm parameter is specified and the system cannot allocate a dedicated MSFP to the new group or FP, the FPs will be brought online and generate an event (SYSTEM: 2052 - mdaHiBwMulticastAlarm). Similarly, if during normal operation there is a failure or removal of resources, an event will be generated if the system cannot maintain separation of MSFPs for the MDAs.

The **no** form of the command removes the high-bandwidth IP multicast source designation from the forwarding plane.

**Default** no hi-bw-mcast-src

**Parameters**

**alarm** — Enables event generation if the MDA is required to share an MSFP with another MDA that is in a different group. MDAs within the same group sharing an MSFP will not cause this alarm.

**group** *group-id* — Specifies the logical MSFP group for the MDA. MDAs configured with the same *group-id* will be placed on the same MSFP.

**Values** 0 — 32 (A value of 0 removes the MDA from the group.)

**Default** By default, “none” is used, and the system will attempt to assign a unique MSFP to the MDA.

## shutdown

**Syntax** [**no**] **shutdown**

**Context** config>card>fp>egress>max-wred-control

**Description** This command enables or disables egress WRED queue support on the IOM. By default, WRED queue support is disabled (shutdown). While disabled, the various wred-queue-control commands may be executed on the IOM and SAP egress QoS policies with wred-queue enabled may be applied to egress SAPs. The IOM will allocate WRED pools to the WRED queues and the appropriate WRED mega-pool size and CBS reserve size will be calculated, but the WRED mega-pool will be empty and all buffers will be allocated to the default mega-pool. Each WRED queue will be mapped to either its appropriate default pool or an explicitly defined named pool.

Once the **no shutdown** command is executed, the calculated WRED mega-pool buffers will be moved from the default mega-pool to the WRED mega-pool. The WRED mega-pool CBS reserve size will be applied and each egress WRED queue will be moved from its default mega-pool buffer pool to its WRED pool within the WRED mega-pool hierarchy.

The **no** form of the command enables WRED queuing on an egress XMA.

## ingress

**Syntax** **ingress**

**Context** config>card>fp

**Description** The ingress CLI node within the **fp** node contains the multicast path management configuration commands for IOM-3 ingress multicast management. The **bandwidth-policy** command is supported within the ingress node.

### stable-pool-sizing

**Syntax** [no] stable-pool-sizing

**Context** config>card>fp

**Description** The stable-pool-sizing command is used to provide a stable buffer pool allocation environment for all default port buffer pools on a forwarding plane. This stable environment is provided at the expense of optimal buffer allocation between the various port buffer pools. Normally, port pools are sized according to a ports relative bandwidth with other ports and the ability of a port to use pool buffers. As an example, on a forwarding plane with two potential MDAs and only one equipped, the normal behavior is to provide all available default pool buffers to the ports on the currently equipped MDA. If a second MDA is equipped in the future, buffers are freed from the existing MDA and provided to the ports on the new MDA. Stable pool sizing alters this behavior by reserving buffers for both MDAs whether they are equipped or not thus preventing a resizing event when an MDA is equipped. In addition, existing ports on a module always receive their maximum bandwidth share of buffers independent on any sub-rate condition that may currently exist. This provides a stable amount of buffers to other ports on the module independent of link or configuration events that may occur on the port.

Stable pool sizing preserves the ability to modify the effective bandwidth used to determine a port's relative share of the available buffers through the use of the ing-percentage-of-rate and egr-percentage-of-rate commands under the port configuration. Changing the values associated with these commands will cause a reevaluation of buffer distribution and thus a possible resizing of pools on each port within the module. These commands have no effect on ports associated with other modules on the forwarding plane.

Stable pool sizing is mutually exclusive with card level named-pool-mode. Named pool mode must be disabled and not operational before stable pool sizing can be enabled. Once stable pool sizing is enabled on any forwarding plane on a card, named-pool-mode cannot be enabled for that card.

Stable pool sizing may be enabled (while named pool mode is disabled) or disabled at any time on a forwarding plane. The system will dynamically change the pool sizes according to the stable pool sizing state.

The **no** stable-pool-sizing command is used to disable stable pool sizing on a forwarding plane. Existing buffer pools will be resized according to normal pool sizing behavior.

### access

**Syntax** access

**Context** config>card>fp>ingress

**Description** This CLI node contains the access forwarding-plane parameters.

## queue-group

|                    |                                                                                                                                                                                                                                                                                                                                                                                                                                                                                                                                                                                                                                                                                         |
|--------------------|-----------------------------------------------------------------------------------------------------------------------------------------------------------------------------------------------------------------------------------------------------------------------------------------------------------------------------------------------------------------------------------------------------------------------------------------------------------------------------------------------------------------------------------------------------------------------------------------------------------------------------------------------------------------------------------------|
| <b>Syntax</b>      | <b>queue-group</b> <i>queue-group-name</i> <b>instance</b> <i>instance-id</i> [ <b>create</b> ]<br><b>no queue-group</b>                                                                                                                                                                                                                                                                                                                                                                                                                                                                                                                                                                |
| <b>Context</b>     | config>card>fp>ingress>access                                                                                                                                                                                                                                                                                                                                                                                                                                                                                                                                                                                                                                                           |
| <b>Description</b> | <p>This command creates an instance of a named queue group template on the ingress forwarding plane of a given IOM/IMM. The <i>queue-group-name</i> and <b>instance</b> <i>instance-id</i> are mandatory parameters when executing the command.</p> <p>The named queue group template can contain only policers. If it contains queues, then the command will fail.</p> <p>The <b>no</b> form of the command deletes a specific instance of a queue group.</p>                                                                                                                                                                                                                          |
| <b>Default</b>     | none                                                                                                                                                                                                                                                                                                                                                                                                                                                                                                                                                                                                                                                                                    |
| <b>Parameters</b>  | <p><i>queue-group-name</i> — Specifies the name of the queue group template to be instantiated on the forwarding plane of the IOM/IMM, up to 32 characters in length. The <i>queue-group-name</i> must correspond to a valid ingress queue group template name, configured under <b>config&gt;qos&gt;queue-group-templates</b>.</p> <p><i>instance-id</i> — specifies the instance of the named queue group to be created on the IOM/IMM ingress forwarding plane.</p> <p><b>Values</b>      1 — 16383</p> <p><b>create</b> — Keyword used to associate the queue group. The <b>create</b> keyword requirement can be enabled/disabled in the <b>environment&gt;create</b> context.</p> |

## queue-group

|                    |                                                                                                                                                                                                                                                                                                                                                                                                                                                                                                                                                                                                                                                                                                                                                                                                                                                                                                                              |
|--------------------|------------------------------------------------------------------------------------------------------------------------------------------------------------------------------------------------------------------------------------------------------------------------------------------------------------------------------------------------------------------------------------------------------------------------------------------------------------------------------------------------------------------------------------------------------------------------------------------------------------------------------------------------------------------------------------------------------------------------------------------------------------------------------------------------------------------------------------------------------------------------------------------------------------------------------|
| <b>Syntax</b>      | <b>queue-group</b> <i>queue-group-name</i> <b>instance</b> <i>instance-id</i><br><b>no queue-group</b>                                                                                                                                                                                                                                                                                                                                                                                                                                                                                                                                                                                                                                                                                                                                                                                                                       |
| <b>Context</b>     | config>card>fp>ingress>network                                                                                                                                                                                                                                                                                                                                                                                                                                                                                                                                                                                                                                                                                                                                                                                                                                                                                               |
| <b>Description</b> | <p>This command is used to create a queue-group instance in the network ingress context of a forwarding plane.</p> <p>Only a queue-group containing policers can be instantiated. If the queue-group template contains policers and queues, the queues are not instantiated. If the queue-group contains queues only, the instantiation in the data path is failed.</p> <p>One or more instances of the same policer queue-group name and/or a different policer queue-group name can be created on the network ingress context of a forwarding plane.</p> <p>The <i>queue-group-name</i> must be unique within all network ingress and access ingress queue groups in the system. The <i>queue-group instance-id</i> must be unique within the context of the forwarding plane.</p> <p>The <b>no</b> version of this command deletes the queue-group instance from the network ingress context of the forwarding plane.</p> |
| <b>Default</b>     | none                                                                                                                                                                                                                                                                                                                                                                                                                                                                                                                                                                                                                                                                                                                                                                                                                                                                                                                         |
| <b>Parameters</b>  | <i>queue-group-name</i> — Specifies the name of the queue group template up to 32 characters in length.                                                                                                                                                                                                                                                                                                                                                                                                                                                                                                                                                                                                                                                                                                                                                                                                                      |

## Multi-Chassis Redundancy Commands

*instance-id* — pecifies the identification of a specific instance of the queue-group.

**Values** 1— 16384

### accounting-policy

**Syntax** **accounting-policy** *policy-name*  
**no accounting-policy**

**Context** config>card>fp>ingress>access>queue-group  
config>card>fp>ingress>network>queue-group

**Description** This command configures an accounting policy that can apply to a queue-group on the forwarding plane. An accounting policy must be configured before it can be associated to an interface. If the accounting *policy-id* does not exist, an error is returned. Accounting policies associated with service billing can only be applied to SAPs. The accounting policy can be associated with an interface at a time. The **no** form of this command removes the accounting policy association from the queue-group.

**Default** No accounting policies are specified by default. You must explicitly specify a policy. If configured, the accounting policy configured as the default is used.

**Parameters** *policy-name* — Specifies the name of the accounting policy to use for the queue-group.

### collect-stats

**Syntax** [**no**] **collect-stats**

**Context** config>card>fp>ingress>access>queue-group  
config>card>fp>ingress>network>queue-group

**Description** This command enables the collection of accounting and statistical data for the queue group on the forwarding plane. When applying accounting policies, the data, by default, is collected in the appropriate records and written to the designated billing file.

When the **no collect-stats** command is issued, the statistics are still accumulated, however, the CPU does not obtain the results and write them to the billing file. If the **collect-stats** command is issued again (enabled), then the counters written to the billing file will include the traffic collected while the **no collect-stats** command was in effect.

**Default** no collect-stats

## policer-control-policy

|                    |                                                                                                                                                                                                                    |
|--------------------|--------------------------------------------------------------------------------------------------------------------------------------------------------------------------------------------------------------------|
| <b>Syntax</b>      | <b>policer-control-policy</b> <i>policy-name</i><br><b>no policer-control-policy</b>                                                                                                                               |
| <b>Context</b>     | config>card>fp>ingress>access>queue-group<br>config>card>fp>ingress>network>queue-group                                                                                                                            |
| <b>Description</b> | This command configures an policer-control policy that can apply to a queue-group on the forwarding plane. The <b>no</b> form of this command removes the policer-control policy association from the queue-group. |
| <b>Default</b>     | No policer-control policies are specified by default. You must explicitly specify a policy.                                                                                                                        |
| <b>Parameters</b>  | <i>policy-name</i> — Specifies the name of the policer-control policy to use for the queue-group.                                                                                                                  |

## ingress-buffer-allocation

|                    |                                                                                                                                                                                                                                                                                                                                                                                                                                                                                                                                                                                                                                                                                |
|--------------------|--------------------------------------------------------------------------------------------------------------------------------------------------------------------------------------------------------------------------------------------------------------------------------------------------------------------------------------------------------------------------------------------------------------------------------------------------------------------------------------------------------------------------------------------------------------------------------------------------------------------------------------------------------------------------------|
| <b>Syntax</b>      | <b>ingress-buffer-allocation</b> <i>hundredths-of-a-percent</i><br><b>no ingress-buffer-allocation</b>                                                                                                                                                                                                                                                                                                                                                                                                                                                                                                                                                                         |
| <b>Context</b>     | config>card>fp>ingress                                                                                                                                                                                                                                                                                                                                                                                                                                                                                                                                                                                                                                                         |
| <b>Description</b> | This command allows the user to configure an ingress buffer allocation percentage per forwarding plane from 20.00% to 80.00%. Ingress buffer allocation applies to user-accessible buffers (total buffers less those reserved for system use).<br><br>The ingress buffer allocation percentage determines how much of the user-accessible buffers will be available for ingress purposes. The remaining buffers will be available for egress purposes.<br><br><b>NOTE:</b> This feature is supported on all 50G FP2-based line cards and 100G/200G FP3-based line cards.<br><br>The <b>no</b> form of this command returns the ingress buffer allocation to the default value. |
| <b>Default</b>     | The default value is 50.00%, which emulates the legacy behavior.                                                                                                                                                                                                                                                                                                                                                                                                                                                                                                                                                                                                               |

## max-rate

|                    |                                                                                                                                                                                                                                                                                                                                                                                                                                                                                                                                                                                                                                                                                                                |
|--------------------|----------------------------------------------------------------------------------------------------------------------------------------------------------------------------------------------------------------------------------------------------------------------------------------------------------------------------------------------------------------------------------------------------------------------------------------------------------------------------------------------------------------------------------------------------------------------------------------------------------------------------------------------------------------------------------------------------------------|
| <b>Syntax</b>      | <b>max-rate</b> { <i>kilobits-per-second</i>   <b>max</b> }<br><b>no max-rate</b>                                                                                                                                                                                                                                                                                                                                                                                                                                                                                                                                                                                                                              |
| <b>Context</b>     | config>card>fp>ingress>acc>qgrp>policer-ctrl-over<br>config>card>fp>ingress>network>qgrp>policer-ctrl-over                                                                                                                                                                                                                                                                                                                                                                                                                                                                                                                                                                                                     |
| <b>Description</b> | This command defines the parent policer's PIR leaky bucket's decrement rate. A parent policer is created for each time the policer-control-policy is applied to either a SAP or subscriber instance. Packets that are not discarded by the child policers associated with the SAP or subscriber instance are evaluated against the parent policer's PIR leaky bucket.<br><br>For each packet, the bucket is first decremented by the correct amount based on the decrement rate to derive the current bucket depth. The current depth is then compared to one of two discard thresholds associated with the packet. The first discard threshold (discard-unfair) is applied if the FIR (Fair Information Rate) |

## Multi-Chassis Redundancy Commands

leaky bucket in the packet's child policer is in the conforming state. The second discard threshold (discard-all) is applied if the child policer's FIR leaky bucket is in the exceed state. Only one of the two thresholds is applied per packet. If the current depth of the parent policer PIR bucket is less than the threshold value, the parent PIR bucket is in the conform state for that particular packet. If the depth is equal to or greater than the applied threshold, the bucket is in the violate state for the packet.

If the result is "conform," the bucket depth is increased by the size of the packet (plus or minus the per-packet-offset setting in the child policer) and the packet is not discarded by the parent policer. If the result is "violate," the bucket depth is not increased and the packet is discarded by the parent policer. When the parent policer discards a packet, any bucket depth increases (PIR, CIR and FIR) in the parent policer caused by the packet are canceled. This prevents packets that are discarded by the parent policer from consuming the child policers PIR, CIR and FIR bandwidth.

The **policer-control-policy root max-rate** setting may be overridden on each SAP or sub-profile where the policy is applied.

**Default** max

**Parameters** *kilobits-per-second* — Defining a kilobits-per-second value is mutually exclusive with the max parameter. The kilobits-per-second value must be defined as an integer that represents the number of kilobytes that the parent policer will be decremented per second. The actual decrement is performed per packet based on the time that has elapsed since the last packet associated with the parent policer.

**Values** Integer 0 – 2000000000

*max* — The **max** parameter is mutually exclusive with defining a **kilobits-per-second** value. When max is specified, the parent policer does not enforce a maximum rate on the aggregate throughput of the child policers. This is the default setting when the **policer-control-policy** is first created and is the value that the parent policer returns to when no max-rate is executed. In order for the parent policer to be effective, a kilobits-per-second value should be specified.

*no max-rate* — The **no max-rate** command returns the policer-control-policy's parent policer maximum rate to max.

## priority-mbs-thresholds

**Syntax** **priority-mbs-thresholds**

**Context** config>card>fp>ingress>access>queue-group>policer-control-override  
config>card>fp>ingress>network>queue-group>policer-control-override

**Description** This command contains the root arbiter parent policer's **min-thresh-separation** command and each priority level's **mbs-contribution** command that is used to internally derive each priority level's shared-portion and fair-portion values. The system uses each priority level's shared-portion and fair-portion value to calculate each priority level's discard-unfair and discard-all MBS thresholds that enforce priority sensitive rate-based discards within the root arbiter's parent policer.

The **priority-mbs-thresholds** CLI node always exists and does not need to be created.

**Default** None.

## min-thresh-separation

**Syntax** **min-thresh-separation** *size* [bytes | kilobytes]  
**no min-thresh-separation**

**Context** config>card>fp>ingress>access>queue-group>policer-control-override>priority-mbs-thresholds  
 config>card>fp>ingress>network>queue-group>policer-control-override>priority-mbs-thresholds

**Description** This command defines the minimum required separation between each in-use discard threshold maintained for each parent policer context associated with the policer-control-policy. The min-thresh-separation value may be overridden on each SAP or sub-profile to which the policy is applied.

The system uses the default or specified min-thresh-separation value in order to determine the minimum separation required between each of the of the parent policer discard thresholds. The system enforces the minimum separation based on the following behavior in two ways. The first is determining the size of the shared-portion for each priority level (when the **mbs-contribution** command's optional fixed keyword is not specified):

- When a parent policer instance's priority level has less than two child policers associated, the shared-portion for the level will be zero.
- When a parent policer instance's priority level has two or more child policers associated, the shared-portion for the level will be equal to the current value of **min-thresh-separation**.

The second function the system uses the **min-thresh-separation** value for is determining the value per priority level for the fair-portion:

- When a parent policer instance's priority level has no child policers associated, the fair-portion for the level will be zero.
- When a parent policer instance's priority level has one child policer associated, the fair-portion will be equal to the maximum of the min-thresh-separation value and the priority level's mbs-contribution value.
- When a parent policer instance's priority level has two or more child policers associated, the fair-portion will be equal to the maximum of the following:
  - min-thresh-separation** value
  - The priority level's **mbs-contribution** value less **min-thresh-separation** value

When the **mbs-contribution** command's optional fixed keyword is defined for a priority level within the policy, the system will treat the defined **mbs-contribution** value as an explicit definition of the priority level's MBS. While the system will continue to track child policer associations with the parent policer priority levels, the association counters will have no effect. Instead the following rules will be used to determine a fixed priority level's shared-portion and fair-portion:

- If a fixed priority level's **mbs-contribution** value is set to zero, both the shared-portion and fair-portion will be set to zero
- If the **mbs-contribution** value is not set to zero:
  - The shared-portion will be set to the current **min-thresh-separation** value
  - The fair-portion will be set to the maximum of the following:
    - min-thresh-separation** value
    - mbs-contribution** value less **min-thresh-separation** value

## Multi-Chassis Redundancy Commands

Each time the **min-thresh-separation** value is modified, the thresholds for all instances of the parent policer created through association with this **policer-control-policy** are reevaluated except for parent policer instances that currently have a min-thresh-separation override.

### Determining the Correct Value for the Minimum Threshold Separation Value

The minimum value for **min-thresh-separation** should be set equal to the maximum size packet that will be handled by the parent policer. This ensures that when a lower priority packet is incrementing the bucket, the size of the increment will not cause the bucket's depth to equal or exceed a higher priority threshold. It also ensures that an unfair packet within a priority level cannot cause the PIR bucket to increment to the discard-all threshold within the priority.

When evaluating maximum packet size, each child policer's per-packet-offset setting should be taken into consideration. If the maximum size packet is 1518 bytes and a per-packet-offset parameter is configured to add 20 bytes per packet, min-thresh-separation should be set to 1538 due to the fact that the parent policer will increment its PIR bucket using the extra 20 bytes.

In most circumstances, a value larger than the maximum packet size is not necessary. Management of priority level aggregate burst tolerance is intended to be implemented using the priority level **mbs-contribution** command. Setting a value larger than the maximum packet size will not adversely affect the policer performance, but it may increase the aggregate burst tolerance for each priority level.

One thing to note is that a priority level's shared-portion of the parent policer's PIR bucket depth is only necessary to provide some separation between a lower priority's discard-all threshold and this priority's discard-unfair threshold. It is expected that the burst tolerance for the unfair packets is relatively minimal since the child policers feeding the parent policer priority level all have some amount of fair burst before entering into an FIR exceed or unfair state. The fair burst amount for a priority level is defined using the mbs-contribution command.

The **no** form of this command returns the policy's **min-thresh-separation** value to the default value. This has no effect on instances of the parent policer where **min-thresh-separation** is overridden unless the override is removed.

**Default** **no min-thresh-separation**

### Parameters

**size** [**bytes** | **kilobytes**] — The size parameter is required when executing the **min-thresh-separation** command. It is expressed as an integer and specifies the shared portion in bytes or kilobytes that is selected by the trailing bytes or kilobytes keywords. If both bytes and kilobytes are missing, kilobytes is the assumed value. Setting this value has no effect on parent policer instances where the **min-thresh-separation** value has been overridden. Clearing an override on parent policer instance causes this value to be enforced.

**Values** 0 – 16777216

**Default** none

[**bytes** | **kilobytes**] — The **bytes** keyword is optional and is mutually exclusive with the **kilobytes** keyword. When specified, size is interpreted as specifying the size of **min-thresh-separation** in bytes.

The **kilobytes** keyword is optional and is mutually exclusive with the **bytes** keyword. When specified, size is interpreted as specifying the size of **min-thresh-separation** in kilobytes.

**Values** **bytes** or **kilobytes**

**Default** **kilobytes**

## priority

**Syntax** `priority level`

**Context** `config>card>fp>ingress>access>queue-group>policer-control-override>priority-mbs-thresholds`  
`config>card>fp>ingress>network>queue-group>policer-control-override>priority-mbs-thresholds`

**Description** The **priority** level command contains the **mbs-contribution** configuration command for a given strict priority level. Eight levels are supported numbered 1 through 8 with 8 being the highest strict priority.

Each of the eight priority CLI nodes always exists and do not need to be created. While parameters exist for each priority level, the parameters are only applied when the priority level within a parent policer instance is currently supporting child policers.

**Default** None.

## mbs-contribution

**Syntax** `mbs-contribution size [bytes | kilobytes] [fixed]`  
`no mbs-contribution`

**Context** `config>card>fp>ingress>access>queue-group>policer-control-override>priority-mbs-thresholds`  
`config>card>fp>ingress>network>queue-group>policer-control-override>priority-mbs-thresholds`

**Description** The **mbs-contribution** command is used to configure the policy-based burst tolerance for a parent policer instance created when the policy is applied to a SAP or subscriber context. The system uses the parent policer's **min-thresh-separation** value, the priority level's **mbs-contribution** value and the number of child policers currently attached to the priority level to derive the priority level's shared-portion and fair-portion of burst tolerance within the local priority level. The shared-portion and fair-portions for each priority level are then used by the system to calculate each priority level's discard-unfair threshold and discard-all threshold.

The value for a priority level's **mbs-contribution** within the policer-control-policy may be overridden on the SAP or subscriber sub-profile where the policy is applied in order to allow fine tuning of the discard-unfair and discard-all thresholds relevant to the needs of the local child policers on the object.

### Accumulative Nature of Burst Tolerance for a Parent Policer Priority Level

When defining **mbs-contribution**, the specified size may only be a portion of the burst tolerance associated with the priority level. The packets associated with the priority level share the burst tolerance of lower within the parent policer. As the parent policer PIR bucket depth increases during congestion, the lower priority packets eventually experience discard based on each priority's discard-unfair and discard-all thresholds. Assuming congestion continues once all the lower priority packets have been prevented from consuming bucket depth, the burst tolerance for the priority level will be consumed by its own packets and any packets associated with higher priorities.

### The Effect of Fair and Unfair Child Policer Traffic at a Parent Policer Priority Level

The system continually monitors the offered rate of each child policer on each parent policer priority level and detects when the policer is in a congested state (the aggregate offered load is greater than the decrement rate defined on the parent policer). As previously stated, the result of congestion is that the parent policer's bucket depth will increase until it eventually hovers around either a discard-unfair or discard-all threshold

belonging to one of the priority levels. This threshold is the point where enough packets are being discarded that the increment rate and decrement rate begin to even out. If only a single child policer is associated to the priority level, the discard-unfair threshold is not used since fairness is only applicable when multiple child policers are competing at the same priority level.

When multiple child policers are sharing the congested priority level, the system uses the offered rates and the parenting parameters of each child to determine the fair rate per child when the parent policer is unable to meet the bandwidth needs of each child. The fair rate represents the amount of bandwidth that each child at the priority level should receive relative to the other children at the same level according to the policer control policy instance managing the child policers. This fair rate is applied as the decrement rate for each child's FIR bucket. Changing a child's FIR rate does not modify the amount of packets forwarded by the parent policer for the child's priority level. It simply modifies the forwarded ratio between the children on that priority level. Since each child FIR bucket has some level of burst tolerance before marking its packets as unfair, the current parent policer bucket depth may at times rise above the discard-unfair threshold. The mbs-contribution value provides a means to define how much separation is provided between the priority level's discard-unfair and discard-all threshold to allow the parent policer to absorb some amount of FIR burst before reaching the priority's discard-all threshold.

This level of fair aggregate burst tolerance is based on the decrement rate of the parent policer's PIR bucket while the individual fair bursts making up the aggregate are based on each child's FIR decrement rate. The aggregate fair rate of the priority level is managed by the system with consideration of the current rate of traffic in higher priority levels. In essence, the system ensures that for each iteration of the child FIR rate calculation, the sum of the child FIR decrement rates plus the sum of the higher priority traffic increment rates equals the parent policers decrement rate. This means that dynamic amounts of higher priority traffic can be ignored when sizing a lower priority's fair aggregate burst tolerance. Consider the following:

- The parent policer decrement rate is set to 20 Mbps (max-rate 20,000).
- A priority level's fair burst size is set to 30 Kbytes (mbs-contribution 30 kilobytes).
- Higher priority traffic is currently taking 12 Mbps.
- The priority level has three child policers attached.
- Each child's PIR MBS is set to 10 Kbytes, which makes each child's FIR MBS 10 Kbytes.
- The children want 10 Mbps, but only 8 Mbps is available,
- Based on weights, the children's FIR rates are set as follows:

|         | FIR Rate | FIR MBS   |
|---------|----------|-----------|
| Child 1 | 4 Mbps   | 10 Kbytes |
| Child 2 | 3 Mbps   | 10 Kbytes |
| Child 3 | 1 Mbps   | 10 Kbytes |

The 12 Mbps of the higher priority traffic and the 8 Mbps of fair traffic equal the 20 Mbps decrement rate of the parent policer.

It is clear that the higher priority traffic is consuming 12 Mbps of the parent policer's decrement rate, leaving 8 Mbps of decrement rate for the lower priority's fair traffic.

- The burst tolerance of child 1 is based on 10 Kbytes above 4 Mbps,
- The burst tolerance of child 2 is based on 10 Kbytes above 3 Mbps,

- The burst tolerance of child 3 is based on 10 Kbytes above 1 Mbps.

If all three children burst simultaneously (unlikely), they will consume 30 Kbytes above 8 Mbps. This is the same as the remaining decrement rate after the higher priority traffic.

#### Parent Policer Total Burst Tolerance and Downstream Buffering

The highest in-use priority level's discard-all threshold is the total burst tolerance of the parent policer. In some cases the parent policer represents downstream bandwidth capacity and the max-rate of the parent policer is set to prevent overrunning the downstream bandwidth. The burst tolerance of the parent policer defines how much more traffic may be sent beyond the downstream scheduling capacity. In the worst case scenario, when the downstream buffering is insufficient to handle the total possible burst from the parent policer, downstream discards based on lack of buffering may occur. However, in all likelihood, this is not the case.

In most cases, lower priority traffic in the policer will be responsible for the greater part of congestion above the parent policer rate. Since this traffic is discarded with a lower threshold, this lowers the effective burst tolerance even while the highest priority traffic is present.

#### Configuring a Priority Level's MBS Contribution Value

In the most conservative case, a priority level's **mbs-contribution** value may be set to be greater than the sum of child policer's mbs and one max-size-frame per child policer. This ensures that even in the absolute worst case where all the lower priority levels are simultaneously bursting to the maximum capacity of each child, enough burst tolerance for the priority's children will exist if they also burst to their maximum capacity.

Since simply adding up all the child policer's PIR MBS values may result in large overall burst tolerances that are not ever likely to be needed, you should consider some level of burst oversubscription when configuring the **mbs-contribution** value for each priority level. The amount of oversubscription should be determined based on the needs of each priority level.

#### Using the Fixed Keyword to Create Deterministic Parent Policer Discard Thresholds

In the default behavior, the system ignores the **mbs-contribution** values for a priority level on a subscriber or SAP parent policer when a child policer is not currently associated with the level. This prevents additional burst tolerance from being added to higher priority traffic within the parent policer.

This does cause fluctuations in the defined threshold values when child policers are added or removed from a parent policer instance. If this behavior is undesirable, the fixed keyword may be used which causes the **mbs-contribution** value to always be included in the calculation of parent policer's discard thresholds. The defined **mbs-contribution** value may be overridden on a subscriber sla-profile or on a SAP instance, but the fixed nature of the contribution cannot be overridden.

If the defined **mbs-contribution** value for the priority level is zero, the priority level will have no effect on the parent policer's defined discard thresholds. A packet associated with the priority level will use the next lower priority level's discard-unfair and discard-all thresholds.

#### Parameters

*size* [**bytes** | **kilobytes**] — The size parameter is required when executing the **mbs-contribution** command. It is expressed as an integer and specifies the priority's specific portion amount of accumulative MBS for the priority level in bytes or kilobytes which is selected by the trailing **bytes** or **kilobytes** keywords. If both **bytes** and **kilobytes** are missing, **kilobytes** is assumed. Setting this value has no effect on parent policer

## Multi-Chassis Redundancy Commands

instances where the priority level's **mbs-contribution** value has been overridden. Clearing an override on parent policer instance causes this value to be enforced.

**Values** 0 — 16777216

**Default** none

**bytes | kilobytes:** — The **bytes** keyword is optional and is mutually exclusive with the **kilobytes** keyword. When specified, size is interpreted as specifying the size of **min-thresh-separation** in bytes.

The **kilobytes** keyword is optional and is mutually exclusive with the **bytes** keyword. When specified, size is interpreted as specifying the size of min-thresh-separation in kilobytes.

**Default** **kilobytes**

**fixed** — The optional fixed keyword is used to force the inclusion of the defined **mbs-contribution** value (or an override value defined on the SAP or sla-profile) in the parent policer's discard threshold calculations. If the **mbs-contribution** command is executed without the **fixed** keyword, the fixed calculation behavior for the priority level is removed.

**Default** **no mbs-contribution**

The **no mbs-contribution** command returns the policy's priority level's MBS contribution to the default value. When changed, the thresholds for the priority level and all higher priority levels for all instances of the parent policer will be recalculated.

## policer-override

**Syntax** **[no] policer-override**

**Context** config>card>fp>ingress>access>queue-group  
config>card>fp>ingress>network>queue-group

**Description** This command, within the SAP ingress or egress contexts, is used to create a CLI node for specific overrides to one or more policers created on the SAP through the sap-ingress or sap-egress QoS policies.  
The **no** form of the command is used to remove any existing policer overrides.

**Default** no policer-overrides

## policer

**Syntax** **policer** *policer-id* [**create**]  
**no policer** *policer-id*

**Context** config>card>fp>ingress>access>qgrp>policer-over  
config>card>fp>ingress>network>qgrp>policer-over

**Description** This command is used in the sap-ingress and sap-egress QoS policies to create, modify or delete a policer. Policers are created and used in a similar manner to queues. The policer ID space is separate from the queue ID space, allowing both a queue and a policer to share the same ID. The sap-ingress policy may have up to 32 policers (numbered 1 through 32) may be defined while the sap-egress QoS policy supports a maximum

of 8 (numbered 1 through 8). While a policer may be defined within a QoS policy, it is not actually created on SAPs or subscribers associated with the policy until a forwarding class is mapped to the policer's ID.

All policers must be created within the QoS policies. A default policer is not created when a sap-ingress or sap-egress QoS policy is created.

Once a policer is created, the policer's metering rate and profiling rates may be defined as well as the policer's maximum and committed burst sizes (MBS and CBS respectively). Unlike queues which have dedicated counters, policers allow various stat-mode settings that define the counters that will be associated with the policer. Another supported feature—packet-byte-offset—provides a policer with the ability to modify the size of each packet based on a defined number of bytes.

Once a policer is created, it cannot be deleted from the QoS policy unless any forwarding classes that are mapped to the policer are first moved to other policers or queues.

The system will allow a policer to be created on a SAP QoS policy regardless of the ability to support policers on objects where the policy is currently applied. The system only scans the current objects for policer support and sufficient resources to create the policer when a forwarding class is first mapped to the policer ID. If the policer cannot be created due to one or more instances of the policy not supporting policing or having insufficient resources to create the policer, the forwarding class mapping will fail.

The **no** form of this command is used to delete a policer from a sap-ingress or sap-egress QoS policy. The specified policer cannot currently have any forwarding class mappings for the removal of the policer to succeed. It is not necessary to actually delete the policer ID for the policer instances to be removed from SAPs or subscribers associated with the QoS policy once all forwarding classes have been moved away from the policer. It is automatically deleted from each policing instance although it still appears in the QoS policy.

**Parameters** *policer-id* — The *policer-id* must be specified when executing the policer command. If the specified ID already exists, the system enters that policer's context to allow the policer's parameters to be modified. If the ID does not exist and is within the allowed range for the QoS policy type, a context for the policer ID will be created (depending on the system's current create keyword requirements which may require the create keyword to actually add the new policer ID to the QoS policy) and the system will enter that new policer's context for possible parameter modification.

**Values** 1—32

## stat-mode

**Syntax** **stat-mode** {**no-stats** | **minimal** | **offered-profile-no-cir** | **offered-priority-no-cir** | **offered-limited-profile-cir** | **offered-profile-cir** | **offered-priority-cir** | **offered-total-cir**}  
**no stat mode**

**Context** config>card>fp>ingress>access>qgrp>policer-over>plcr  
config>card>fp>ingress>network>qgrp>policer-over>plcr

**Description** This command is used to configure the forwarding plane counters that allow offered, output and discard accounting to occur for the policer. An ingress policer has multiple types of offered packets (explicit in-profile, explicit out-of-profile, high priority or low priority) and each of these offered types is interacting with the policer's metering and profiling functions resulting in colored output packets (green, yellow and red). Due to the large number of policers, it is not economical to allocate counters in the forwarding plane for all possible offered packet types and output conditions. Many policers will not be configured with a CIR profiling rate and not all policers will receive explicitly profiled offered packets. The **stat-mode** command allows

## Multi-Chassis Redundancy Commands

provisioning of the number of counters each policer requires and how the offered packet types and output conditions should be mapped to the counters.

While a **no-stats** mode is supported which prevents any packet accounting, the use of the policer's **parent** command requires at the policer's **stat-mode** to be set at least to the **minimal** setting so that offered stats are available for the policer's Fair Information Rate (FIR) to be calculated. Once a policer has been made a child to a parent policer, the **stat-mode** cannot be changed to **no-stats** unless the policer parenting is first removed.

Each time the policer's **stat-mode** is changed, any previous counter values are lost and any new counters are set to zero.

Each mode uses a certain number of counters per policer instance that are allocated from the forwarding plane's policer counter resources. You can view the total/allocated/free stats by using the **tools dump system-resources** command. If insufficient counters exist to implement a mode on any policer instance, the **stat-mode** change will fail and the previous mode will continue unaffected for all instances of the policer.

The default **stat-mode** when a policer is created within the policy is **minimal**.

The **stat-mode** setting defined for the policer in the QoS policy may be overridden on an **sla-profile** or **SAP** where the policy is applied. If insufficient policer counter resources exist to implement the override, the **stat-mode** override command will fail. The previous **stat-mode** setting active for the policer will continue to be used by the policer.

The **no** form of this command attempts to return the policer's stat-mode setting to minimal. The command will fail if insufficient policer counter resources exist to implement minimal where the QoS policer is currently applied and has a forwarding class mapping.

### Parameters **no-stats** — Counter resource allocation:0

The policer does not have any forwarding plane counters allocated and cannot provide offered, discard and forward statistics. A policer using **no-stats** cannot be a child to a parent policer and the policer's parent command will fail.

When **collect-stats** is enabled, the lack of counters causes the system to generate the following statistics:

- a. offered-in = 0
- b. offered-out = 0
- c. discard-in = 0
- d. discard-out = 0
- e. forward-in = 0
- f. forward-out = 0

Counter 0 indicates that the accounting statistic returns a value of zero.

### **minimal** — Counter resource allocation:1

The default **stat-mode** for a policer is **minimal**. The **minimal** mode allocates 1 forwarding plane offered counter and one traffic manager discard counter. The forwarding counter is derived by subtracting the discard counter from the offered counter. The counters do not differentiate possible offered types (profile or priority) and do not count green or yellow output. This does not prevent the policer from supporting different offered packet types and does not prevent the policer from supporting a CIR rate.

This counter mode is useful when only the most basic accounting information is required.

The counters are used in the following manner:

1. 'offered = profile in/out, priority high/low
2. 'discarded = Same as 1
3. 'forwarded= Derived from 1 - 2

When **collect-stats** is enabled, the counters are used by the system to generate the following statistics:

- a. offered-in = 1
- b. offered-out= 0
- c. discard-in = 2
- d. discard-out= 0
- e. forward-in = 3
- f. 'orward-out= 0

Counter 0 indicates that the accounting statistic returns a value of zero.

With **minimal** enabled as the policer **stat-mode**, the SAP offered stats for the policer returned via MIB query and CLI show commands will return the following values:

- i. offered-in = 1
- ii. offered-out= 0
- iii. offered-undefined= 0
- iv. offered-managed= 0(IMPMM managed packets are not redirected from the policer)

Counter 0 indicates that the SAP policer statistic returns a value of zero.

### **offered-profile-no-cir** — Counter resource allocation:2

The **offered-profile-no-cir** mode allocates two forwarding plane offered counters and two traffic manager discard counters.

The **offered-profile-no-cir** mode is most useful when the policer is receiving only in-profile and out-of-profile pre-marked (and trusted) packets. It is expected that in this instance a CIR rate will not be defined since all packet are already pre-marked. This mode does not prevent the policer from receiving un-trusted (color undefined) nor does it prevent the policer from being configured with a CIR rate.

The counters are used in the following manner:

1. offered-in = profile in
2. offered-out= profile out, priority high/low
3. dropped-in= Same as 1
4. dropped-out= Same as 2
5. forwarded-in= Derived from 1 - 3
6. forwarded-out= Derived from 2 - 4

When **collect-stats** is enabled, the counters are used by the system to generate the following statistics:

## Multi-Chassis Redundancy Commands

- a. offered-in = 1
- b. offered-out= 2
- c. discard-in = 3
- d. discard-out= 4
- e. forward-in = 5
- f. forward-out= 6

With **offered-profile-no-cir** enabled as the policer **stat-mode**, the SAP offered stats for the policer returned via MIB query and CLI show commands will return the following values:

- i. offered-in = 1
- ii. offered-out= 2
- iii. offered-undefined= 0
- iv. offered-managed= 0(IMPMM managed packets are not redirected from the policer)

Counter 0 indicates that the SAP policer statistic returns a value of zero.

### **offered-priority-no-cir** — Counter resource allocation:2

The **offered-priority-no-cir** mode allocates two forwarding plane offered counters and two traffic manager discard counters.

The **offered-priority-no-cir** mode is most useful when the policer is receiving only un-trusted packets and the ingress priority high and priority low classification options are being used without a CIR profiling rate defined. This mode does not prevent the policer from receiving trusted packets that are pre-marked in-profile or out-of-profile nor does it prevent the policer from being configured with a CIR rate.

The counters are used in the following manner:

- 1. offered-high = profile in, priority high
- 2. offered-low= profile out, priority low
- 3. dropped-high= Same as 1
- 4. dropped-low= Same as 2
- 5. forwarded-high= Derived from 1 - 3
- 6. forwarded-low= Derived from 2 - 4

When **collect-stats** is enabled, the counters are used by the system to generate the following statistics:

- a. offered-high= 1
- b. offered-low= 2
- c. discard-high= 3
- d. discard-low= 4
- e. forward-high= 5
- f. forward-low= 6

With **offered-priority-no-cir** enabled as the policer **stat-mode**, the SAP offered stats for the policer returned via MIB query and CLI show commands will return the following values:

- i. offered-high= 1
  - ii. offered-low= 2
  - iii. offered-undefined= 0
  - iv. offered-managed= 0 (IMPM managed packets are not redirected from the policer)
- Counter 0 indicates that the SAP policer statistic returns a value of zero.

**offered-limited-profile-cir** — Counter resource allocation:3

The **offered-limited-profile-cir** mode allocates three forwarding plane offered counters and three traffic manager discard counters.

The **offered-limited-profile-cir** mode is most useful when the policer is receiving trusted out-of-profile (profile out but no profile in) traffic and un-trusted packets are being applied to a defined CIR profiling rate. This mode does not prevent the policer from receiving trusted in-profile packets.

The counters are used in the following manner:

- 1. offered-undefined-that-turned-green= profile in, priority high/low
- 2. offered-undefined-that-turned-yellow-or-red= priority high/low
- 3. offered-out-that-stayed-yellow-or-turned-red= profile out
- 4. dropped-undefined-that-turned-green= Same as 1
- 5. dropped-undefined-that-turned-yellow-or-red= Same as 2
- 6. dropped-out-that-turned-yellow-or-red= Same as 3
- 7. forwarded-undefined-that-turned-green= Derived from 1 - 4
- 8. forwarded-undefined-that-turned-yellow= Derived from 2 - 5
- 9. forwarded-out-that-turned-yellow= Derived from 3 - 6

When **collect-stats** is enabled, the counters are used by the system to generate the following statistics:

- a. offered-in = 0
- b. offered-out= 1 + 2 + 3
- c. discard-in = 0
- d. discard-out= 4 + 5 + 6
- e. forward-in = 7
- f. 'orward-out= 8 + 9

With **offered-limited-profile-cir** enabled as the policer **stat-mode**, the SAP offered stats for the policer returned via MIB query and CLI show commands will return the following values:

- i. offered-in = 0
- ii. 'offered-out= 3
- iii. 'offered-undefined= 1 + 2

## Multi-Chassis Redundancy Commands

iv. offered-managed= 0 (IMPM managed packets are not redirected from the policer)

Counter 0 indicates that the SAP policer statistic returns a value of zero.

**offered-profile-cir** — Counter resource allocation:4

The **offered-profile-cir** mode allocates four forwarding plane offered counters and four traffic manager discard counters.

The **offered-profile-cir** mode is most useful when the policer is receiving trusted out-of-profile and in-profile traffic and is also receiving un-trusted packets that are being applied to a defined CIR profiling rate. This mode differs from **offered-limited-profile-cir** mode in that it expects both trusted in-profile and out-of-profile packets while still performing CIR profiling on packets with un-trusted markings. It is expected that in most cases where both trusted and un-trusted packets are received, the predominate case will not include trusted in-profile packets making the offered-limited-profile-cir accounting mode acceptable.

The counters are used in the following manner:

1. offered-in-that-stayed-green-or-turned-red= profile in
2. offered-undefined-that-turned-green= priority high/low
3. offered-undefined-that-turned-yellow-or-red= priority high/low
4. offered-out-that-stayed-yellow-or-turned-red= profile out
5. dropped-in-that-stayed-green-or-turned-red= Same as 1
6. dropped-undefined-that-turned-green= Same as 2
7. dropped-undefined-that-turned-yellow-or-red= Same as 3
8. dropped-out-that-turned-yellow-or-red= Same as 4
9. forwarded-in-that-stayed-green= Derived from 1 - 5
10. forwarded-undefined-that-turned-green= Derived from 2 - 6
11. forwarded-undefined-that-turned-yellow= Derived from 3 - 7
12. forwarded-out-that-turned-yellow= Derived from 4 - 8

When **collect-stats** is enabled, the counters are used by the system to generate the following statistics:

- a. offered-in = 1
- b. offered-out= 2 + 3 + 4
- c. discard-in = 5 + 6
- d. discard-out= 7 + 8
- e. forward-in = 9 + 10
- f. forward-out= 11 + 12

With **offered-profile-cir** enabled as the policer **stat-mode**, the SAP offered stats for the policer returned via MIB query and CLI show commands will return the following values:

- i. offered-high= 1
- ii. offered-low= 4

iii. offered-undefined= 2 + 3

iv. offered-managed= 0 (IMPM managed packets are not redirected from the policer)

Counter 0 indicates that the SAP policer statistic returns a value of zero.

**offered-priority-cir** — Counter resource allocation:4

The **offered-priority-cir** mode allocates four forwarding plane offered counters and four traffic manager discard counters.

The **offered-priority-cir** mode is most useful when the policer is receiving only un-trusted packets that are being classified as high priority or low priority and are being applied to a defined CIR profiling rate. This mode differs from **offered-profile-cir** mode in that it does not expect trusted in-profile and out-of-profile packets but does not exclude the ability of the policer to receive them.

The counters are used in the following manner:

1. offered-high-that-turned-green= profile in, priority high
2. offered-high-that-turned-yellow-or-red= profile in, priority high
3. offered-low-that-turned-green= profile out, priority low
4. offered-low-that-turned-yellow-or-red= profile out, priority low
5. dropped-high-that-turned-green= Same as 1
6. dropped-high-that-turned-yellow-or-red= Same as 2
7. dropped-low-that-turned-green= Same as 3
8. dropped-low-that-turned-yellow-or-red= Same as 4
9. forwarded-high-that-turned-green= Derived from 1 - 5
10. forwarded-high-that-turned-yellow= Derived from 2 - 6
11. forwarded-low-that-turned-green= Derived from 3 - 7
12. forwarded-low-that-turned-yellow= Derived from 4 - 8

When **collect-stats** is enabled, the counters are used by the system to generate the following statistics:

- a. offered-high= 1 + 2
- b. offered-low= 3 + 4
- c. discard-in = 5 + 7
- d. discard-out= 6 + 8
- e. forward-in = 9 + 11
- f. forward-out= 10 + 12

With **offered-priority-cir** enabled as the policer **stat-mode**, the SAP offered stats for the policer returned via MIB query and CLI show commands will return the following values:

- i. offered-high= 1 + 2
- ii. offered-low= 3 + 4
- iii. offered-undefined= 0

## Multi-Chassis Redundancy Commands

iv. offered-managed= 0 (IMPM managed packets are not redirected from the policer)

Counter 0 indicates that the SAP policer statistic returns a value of zero.

**offered-total-cir** — Counter resource allocation:2

The **offered-total-cir** mode allocates two forwarding plane offered counters and two traffic manager discard counters.

The **offered-total-cir** mode is most useful when the policer is not receiving trusted in-profile or out-of-profile traffic and both high and low priority classifications are not being used on the un-trusted packets and the offered packets are being applied to a defined CIR profiling rate. This mode does not prevent the policer from receiving trusted in-profile or out-of-profile packets and does not prevent the use of priority high or low classifications on the un-trusted packets.

The counters are used in the following manner:

1. offered-that-turned-green= profile in/out, priority high/low
2. offered- that-turned-yellow-or-red= profile in/out, priority high/low
3. dropped-offered-that-turned-green= Same as 1
4. dropped-offered-that-turned-yellow-or-red= Same as 2
5. forwarded-offered-that-turned-green= Derived from 1 - 3
6. forwarded-offered-that-turned-yellow= Derived from 2 - 4

When **collect-stats** is enabled, the counters are used by the system to generate the following statistics:

- a. offered-in = 1 + 2
- b. offered-out= 0
- c. discard-in = 3
- d. discard-out= 4
- e. forward-in = 5
- f. forward-out= 6

Counter 0 indicates that the accounting statistic returns a value of zero.

With **offered-total-cir** enabled as the policer **stat-mode**, the SAP offered stats for the policer returned via MIB query and CLI show commands will return the following values:

- i. offered-high= 1 + 2
- ii. offered-low= 0
- iii. offered-undefined= 0
- iv. offered-managed= 0 (IMPM managed packets are not redirected from the policer)

Counter 0 indicates that the SAP policer statistic returns a value of zero.

## rate

**Syntax** `rate {max | kilobits-per-second} [cir {max | kilobits-per-second}]`  
`no rate`

**Context** `config>card>fp>ingress>access>qgrp>policer-over>plcr`  
`config>card>fp>ingress>network>qgrp>policer-over>plcr`

**Description** This command is used to configure the policer's metering and optional profiling rates. The metering rate is used by the system to configure the policer's PIR leaky bucket's decrement rate while the profiling rate configures the policer's CIR leaky bucket's decrement rate. The decrement function empties the bucket while packets applied to the bucket attempt to fill it based on the each packets size. If the bucket fills faster than how much is decremented per packet, the bucket's depth eventually reaches it's exceed (CIR) or violate (PIR) threshold. The **cbs**, **mbs**, and **high-prio-only** commands are used to configure the policer's PIR and CIR thresholds.

If a packet arrives at the policer while the bucket's depth is less than the threshold associated with the packet, the packet is considered to be conforming to the bucket's rate. If the bucket depth is equal to or greater than the threshold, the packet is considered to be in the exception state. For the CIR bucket, the exception state is exceeding the CIR rate while the PIR bucket's exception state is violating the PIR bucket rate. If the packet is violating the PIR, the packet is marked red and will be discarded. If the packet is not red, it may be green or yellow based on the conforming or exceeding state from the CIR bucket.

When a packet is red neither the PIR or CIR bucket depths are incremented by the packets size. When the packet is yellow the PIR bucket is incremented by the packet size, but the CIR bucket is not. When the packet is green, both the PIR and CIR buckets are incremented by the packet size. This ensures that conforming packets impact the bucket depth while exceeding or violating packets do not.

The policer's **adaptation-rule** command settings are used by the system to convert the specified rates into hardware timers and decrement values for the policer's buckets.

By default, the policer's metering rate is **max** and the profiling rate is 0 Kbps (all packets out-of-profile).

The **rate** settings defined for the policer in the QoS policy may be overridden on an **sla-profile** or SAP where the policy is applied.

The **no** form of this command is used to restore the default metering and profiling rate to a policer.

**Parameters** `{max | kilobits-per-second}` — Specifying the keyword **max** or an explicit *kilobits-per-second* parameter directly following the rate command is required and identifies the policer's metering rate for the PIR leaky bucket. When the policer is first created, the metering rate defaults to max. The *kilobits-per-second* value must be expressed as an integer and defines the rate in kilobits-per-second. The integer value is multiplied by 1,000 to derive the actual rate in bits-per-second. When max is specified, the maximum policer rate used will be equal to the maximum capacity of the card on which the policer is configured. If the policer rate is set to a value larger than the maximum rate possible for the card, then the PIR used is equivalent to max.

**Values** **max** or 1—2000000000

**cir** `{max | kilobits-per-second}` — The optional **cir** keyword is used to override the default CIR rate of the policer. Specifying the keyword max or an explicit *kilobits-per-second* parameter directly following the cir keyword is required and identifies the policer's profiling rate for the CIR leaky bucket. When the policer is first created, the profiling rate defaults to 0 Kbps. The *kilobits-per-second* value must be expressed as an integer and defines the rate in kilobits-per-second. The integer value is multiplied by

## Multi-Chassis Redundancy Commands

1,000 to derive the actual rate in bits-per-second. When max is specified, the maximum policer rate used will be equal to the maximum capacity of the card on which the policer is configured. If the policer rate is set to a value larger than the maximum rate possible for the card, then the CPIR used is equivalent to max.

max or 0—2000000000cbs

**Syntax**    **cbs** {*size* [**bytes** | **kilobytes**] | **default**}  
              **no cbs**

**Context**    config>card>fp>ingress>access>qgrp>policer-over>plcr  
              config>card>fp>ingress>network>qgrp>policer-over>plcr

**Description**    This command is used to configure the policer's CIR leaky bucket's exceed threshold. The CIR bucket's exceed threshold represents the committed burst tolerance allowed by the policer. If the policer's forwarding rate is equal to or less than the policer's defined CIR, the CIR bucket depth hovers around the 0 depth with spikes up to the maximum packet size in the offered load. If the forwarding rate increases beyond the profiling rate, the amount of data allowed to be in-profile above the rate is capped by the threshold.

The policer's **cbs** size defined in the QoS policy may be overridden on an **sla-profile** or SAP where the policy is applied.

The **no** form of this command returns the policer to its default CBS size.

**Default**    none

**Parameters**    *size* [**bytes** | **kilobytes**] — The *size* parameter is required when specifying **cbs** and is expressed as an integer representing the required size in either bytes or kilobytes. The default is kilobytes. The optional **byte** and **kilobyte** keywords are mutually exclusive and are used to explicitly define whether size represents bytes or kilobytes.

**byte** — When **byte** is defined, the value given for size is interpreted as the queue's MBS value given in bytes.

**kilobyte** — When **kilobytes** is defined, the value is interpreted as the queue's MBS value given in kilobytes.

**Values**      0 — 16777216

**Default**     **kilobyte**

mbs

**Syntax**    **mbs** {*size* [**bytes** | **kilobytes**] | **default**}  
              **no mbs**

**Context**    config>card>fp>ingress>access>qgrp>policer-over>plcr  
              config>card>fp>ingress>network>qgrp>policer-over>plcr

**Description**    This command is used to configure the policer's PIR leaky bucket's high priority violate threshold. The **high-prio-only** command is applied to the MBS value to derive the bucket's low priority violate threshold. For ingress, trusted in-profile packets and un-trusted high priority packets use the policer's high priority vio-

late threshold while trusted out-of-profile and un-trusted low priority packets use the policer's low priority violate threshold. At egress, in-profile packets use the policer's high priority violate threshold and out-of-profile packets use the policer's low priority violate threshold.

The PIR bucket's violate threshold represent the maximum burst tolerance allowed by the policer. If the policer's offered rate is equal to or less than the policer's defined rate, the PIR bucket depth hovers around the 0 depth with spikes up to the maximum packet size in the offered load. If the offered rate increases beyond the metering rate, the amount of data allowed above the rate is capped by the threshold. The low priority violate threshold provides a smaller burst size for the lower priority traffic associated with the policer. Since all lower priority traffic is discarded at the lower burst tolerance size, the remaining burst tolerance defined by **high-prio-only** is available for the higher priority traffic.

The policer's mbs size defined in the QoS policy may be overridden on an sla-profile or SAP where the policy is applied.

The no form of this command returns the policer to its default MBS size.

**Default** None

**Parameters** *size* [**bytes** | **kilobytes**] — The *size* parameter is required when specifying **mbs** and is expressed as an integer representing the required size in either bytes or kilobytes. The default is kilobytes. The optional **byte** and **kilobyte** keywords are mutually exclusive and are used to explicitly define whether size represents bytes or kilobytes.

**byte** — When **byte** is defined, the value given for size is interpreted as the queue's MBS value given in bytes.

**kilobyte** — When **kilobytes** is defined, the value is interpreted as the queue's MBS value given in kilobytes.

**Values** 0 — 16777216

**Default** kilobyte

## packet-byte-offset

**Syntax** **packet-byte-offset** {**add** *bytes* | **subtract** *bytes*}  
**no packet-byte-offset**

**Context** config>card>fp>ingress>access>qgrp>policer-over>plcr  
config>card>fp>ingress>network>qgrp>policer-over>plcr

**Description** This command is used to modify the size of each packet handled by the policer by adding or subtracting a number of bytes. The actual packet size is not modified; only the size used to determine the bucket depth impact is changed. The **packet-byte-offset** command is meant to be an arbitrary mechanism that can be used to either add downstream frame encapsulation or remove portions of packet headers. Both the policing metering and profiling throughput is affected by the offset as well as the stats associated with the policer.

When child policers are adding to or subtracting from the size of each packet, the parent policer's **min-thresh-separation** value should also need to be modified by the same amount.

The policer's **packet-byte-offset** defined in the QoS policy may be overridden on an **sla-profile** or SAP where the policy is applied.

The **no** version of this command is used to remove per packet size modifications from the policer.

## Multi-Chassis Redundancy Commands

|                   |                                                                                                                                                                                                                                                                                                                                                                                                                                                                                                                                                                                                                                                                                                                                                                                                                                                                                                                                                                                                                                                                                                                                                         |
|-------------------|---------------------------------------------------------------------------------------------------------------------------------------------------------------------------------------------------------------------------------------------------------------------------------------------------------------------------------------------------------------------------------------------------------------------------------------------------------------------------------------------------------------------------------------------------------------------------------------------------------------------------------------------------------------------------------------------------------------------------------------------------------------------------------------------------------------------------------------------------------------------------------------------------------------------------------------------------------------------------------------------------------------------------------------------------------------------------------------------------------------------------------------------------------|
| <b>Parameters</b> | <p><b>add bytes</b> — The <b>add</b> keyword is mutually exclusive to the <b>subtract</b> keyword. Either <b>add</b> or <b>subtract</b> must be specified. When <b>add</b> is defined the corresponding bytes parameter specifies the number of bytes that is added to the size each packet associated with the policer for rate metering, profiling and accounting purposes. From the policer's perspective, the maximum packet size is increased by the amount being added to the size of each packet.</p> <p><b>Values</b> 1 — 32</p> <p><b>Default</b> None</p> <p><b>subtract bytes</b> — The <b>subtract</b> keyword is mutually exclusive to the <b>add</b> keyword. Either <b>add</b> or <b>subtract</b> must be specified. When <b>b</b> is defined the corresponding bytes parameter specifies the number of bytes that is subtracted from the size of each packet associated with the policer for rate metering, profiling and accounting purposes. From the policer's perspective, the maximum packet size is reduced by the amount being subtracted from the size of each packet.</p> <p><b>Values</b> 0—31</p> <p><b>Default</b> None</p> |
|-------------------|---------------------------------------------------------------------------------------------------------------------------------------------------------------------------------------------------------------------------------------------------------------------------------------------------------------------------------------------------------------------------------------------------------------------------------------------------------------------------------------------------------------------------------------------------------------------------------------------------------------------------------------------------------------------------------------------------------------------------------------------------------------------------------------------------------------------------------------------------------------------------------------------------------------------------------------------------------------------------------------------------------------------------------------------------------------------------------------------------------------------------------------------------------|

## mcast-path-management

|                    |                                                                                                                                                                                                                                                                 |
|--------------------|-----------------------------------------------------------------------------------------------------------------------------------------------------------------------------------------------------------------------------------------------------------------|
| <b>Syntax</b>      | <b>mcast-path-management</b>                                                                                                                                                                                                                                    |
| <b>Context</b>     | config>card>fp>ingress<br>config>card>mda>ingress                                                                                                                                                                                                               |
| <b>Description</b> | This CLI node contains the forwarding plane or MDA settings for ingress multicast path management. Enter the node to configure the bandwidth-policy, the individual path bandwidth overrides and the administrative state of ingress multicast path management. |

## bandwidth-policy

|                    |                                                                                                                                                                                                                                                                                                                                                                                                                                                                                                                                                              |
|--------------------|--------------------------------------------------------------------------------------------------------------------------------------------------------------------------------------------------------------------------------------------------------------------------------------------------------------------------------------------------------------------------------------------------------------------------------------------------------------------------------------------------------------------------------------------------------------|
| <b>Syntax</b>      | <b>bandwidth-policy</b> <i>policy-name</i><br><b>no bandwidth-policy</b>                                                                                                                                                                                                                                                                                                                                                                                                                                                                                     |
| <b>Context</b>     | config>card>fp>ingress>mcast-path-management<br>config>card>mda>ingress>mcast-path-management                                                                                                                                                                                                                                                                                                                                                                                                                                                                |
| <b>Description</b> | <p>This command is used to explicitly associate a bandwidth policy to a forwarding plane or MDA. The bandwidth policy defines the dynamic rate table and the multicast paths bandwidth and queuing parameters.</p> <p>If a bandwidth policy is not explicitly associated with a forwarding plane or MDA, the default bandwidth policy is used when ingress multicast path management is enabled.</p> <p>The <b>no</b> form of the command removes an explicit bandwidth policy from a forwarding plane or MDA and restores the default bandwidth policy.</p> |

**Parameters** *policy-name* — The *policy-name* parameter is required and defines the bandwidth policy that should be associated with the MDA or forwarding plane for ingress multicast path management. If the policy name does not exist, the `bandwidth-policy` command will fail.

**Values** Any existing bandwidth policy name

**Default** default

## primary-override

**Syntax** **primary-override**

**Context** `config>card>mda>ingress>mcast-mgmt`

**Description** This command enables the context to configure MDA ingress multicast path-limit overrides. The path override CLI nodes are not supported on IOM-3.

## secondary-override

**Syntax** **secondary-override**

**Context** `config>card>mda>ingress>mcast-mgmt`

**Description** This command enables the context to configure MDA ingress multicast path-limit overrides. The path override CLI nodes are not supported on IOM-3.

## ancillary-override

**Syntax** **ancillary-override**

**Context** `config>card>mda>ingress>mcast-mgmt`

**Description** This command enables the context to configure MDA ingress multicast path-limit overrides.

## path-limit

**Syntax** **path-limit** *megabits-per-second*  
**no path-limit**

**Context** `config>card>mda>ingress>mcast-mgmt>primary-override`  
`config>card>mda>ingress>mcast-mgmt>secondary-override`  
`config>card>mda>ingress>mcast-mgmt>ancillary-override`

**Description** The `path-limit` command is used to override the path limits contained in the bandwidth policy associated with the MDA. The path limits are used to give the upper limit that multicast channels may use on each path.

## Multi-Chassis Redundancy Commands

The path-limit commands are not supported on IOM-3.

The no form of the command removes a path limit override from an ingress multicast path and restore the path limit defined in the bandwidth policy associated with the MDA.

**Parameters** *megabits-per-second* — The megabits-per-second parameter is required when executing the path-limit command and is expressed as an integer representing multiples of 1,000,000 bits per second.

|                |                     |           |
|----------------|---------------------|-----------|
| <b>Values</b>  | Primary-override:   | 1 to 2000 |
|                | Secondary-override: | 1 to 2000 |
|                | Ancillary-override: | 1 to 5000 |
| <b>Default</b> | None                |           |

## cpm

**Syntax** `cpm`

**Context** `tools>dump>mcast-path-mgr`

**Description** This command dumps multicast path manager CPM information.

### Sample Output

```
*A:Dut-C# tools dump mcast-path-mgr cpm
McPathMgr[10][0]: 0x763a52c0 blkHoleEval 0
 pPath swPlaneID pathType availBw pathLimit
inUseBw maxUsedBw numSGs
0x763a54c8 2 secondary 1800000
1800000 0 0 0
0x763a56c0 1 primary 1039959 2000000
960041 960041 6
0x763a58b8 15 primary 879910 2000000
1120090 1120090 7
0x763a5ab0 14 primary 879908 2000000
1120092 1120092 7
0x763a5ca8 13 primary 880007 2000000
1119993 1119993 7
0x763a5ea0 12 primary 880172 2000000
...
0x763a7448 0 none 0
0 0 0 0
0x763a7640 0 blackhole 0
0 0 0 0
McPathMgr[8][0]: 0x7639a9d8 blkHoleEval 0
 pPath swPlaneID pathType availBw pathLimit
inUseBw maxUsedBw numSGs
0x7639abe0 1 secondary 1800000
1800000 0 0 0
0x7639add8 15 primary 2000000
2000000 0 0 0
0x7639afd0 14 primary 2000000
...0x7639cd58 0 blackhole 0
0 0 0 0
McPathMgr[9][0]: 0x76398420 blkHoleEval 0
```

## Interface Configuration

```

 pPath swPlaneID pathType availBw pathLimit
inUseBw maxUsedBw numSGs
0x76398628 15 secondary 1800000
1800000 0 0 0
0x76398820 14 primary 2000000
2000000 0 0 0
0x76398a18 13 primary 2000000
2000000 0 0 0
...
0x7639a7a0 0 blackhole 0
0 0 0 0
SwPlane[0]
 pSwPlane totalBw priBw priInUseBw priAvailBw
secBw secInUseBw secAvailBw
0x98ba320 2000000 2000000 0 2000000
1800000 0 1800000
SwPlane[1]
 pSwPlane totalBw priBw priInUseBw priAvailBw
secBw secInUseBw secAvailBw
0x98ba390 2000000 2000000 960041 1039959
1800000 0 1039959
#####

stype inst src grp currBw pathBw pref repl path exp
0 1 10.10.6.33 227.0.0.23 159891 159891 0 0 P N
0 1 10.10.4.10 225.0.0.0 159990 159990 0 0 P N
0 1 10.10.4.27 225.0.0.17 159990 159990 0 0 P N
0 1 10.10.4.43 225.0.0.33 159993 159993 0 0 P N
0 1 10.10.6.47 227.0.0.37 160049 160049 0 0 P N
0 1 10.10.4.59 225.0.0.49 160128 160128 0 0 P N
SwPlane[2]
 pSwPlane totalBw priBw priInUseBw priAvailBw
secBw secInUseBw secAvailBw
0x98ba400 2000000 2000000 1119789 880211
1800000 0 880211
#####
...
#####

stype inst src grp currBw pathBw pref repl path exp
0 1 10.10.6.29 227.0.0.19 159891 159891 0 0 P N
0 1 10.10.4.28 225.0.0.18 159989 159989 0 0 P N
0 1 10.10.4.11 225.0.0.1 159990 159990 0 0 P N
0 1 10.10.4.41 225.0.0.31 159992 159992 0 0 P N
0 1 10.10.6.43 227.0.0.33 160049 160049 0 0 P N
0 1 10.10.6.58 227.0.0.48 160052 160052 0 0 P N
0 1 10.10.4.55 225.0.0.45 160127 160127 0 0 P N
SwPlane[16]
 pSwPlane totalBw priBw priInUseBw priAvailBw
secBw secInUseBw secAvailBw
0x98baa20 2000000 2000000 0 2000000
1800000 0 1800000
SwPlane[17]
 pSwPlane totalBw priBw priInUseBw priAvailBw
secBw secInUseBw secAvailBw
0x98baa90 2000000 2000000 0 2000000
1800000 0 1800000
SwPlane[18]
 pSwPlane totalBw priBw priInUseBw priAvailBw

```

## Multi-Chassis Redundancy Commands

```
secBw secInUseBw secAvailBw
0x98bab00 2000000 2000000 0 2000000
1800000 0 1800000
SwPlane[19]
 pSwPlane totalBw priBw priInUseBw priAvailBw
secBw secInUseBw secAvailBw
0x98bab70 2000000 2000000 0 2000000
1800000 0 1800000
SwPlane[20]
 pSwPlane totalBw priBw priInUseBw priAvailBw
secBw secInUseBw secAvailBw
0x98babe0 2000000 2000000 0 2000000
1800000 0 1800000
SwPlane[21]
 pSwPlane totalBw priBw priInUseBw priAvailBw
secBw secInUseBw secAvailBw
```

---

## Show Commands

---

### Hardware Commands

#### chassis

**Syntax** `chassis [environment] [power-supply] [ccm]`

**Context** show

**Description** This command displays general chassis status information.

**Parameters** **environment** — Displays chassis environmental status information.

**Default** Displays all chassis information.

**power-supply** — Displays chassis power supply status information.

**Default** Displays all chassis information.

**ccm** — Displays chassis control module information.

**Output** **Chassis Output** — The following table describes chassis output fields.

| Label           | Description                                                                                                                                                                                                                                    |
|-----------------|------------------------------------------------------------------------------------------------------------------------------------------------------------------------------------------------------------------------------------------------|
| Name            | The system name for the router.                                                                                                                                                                                                                |
| Type            | Displays the router model number.                                                                                                                                                                                                              |
| Location        | The system location for the device.                                                                                                                                                                                                            |
| Coordinates     | A user-configurable string that indicates the Global Positioning System (GPS) coordinates for the location of the chassis.<br>For example:<br>N 45 58 23, W 34 56 12<br>N37 37' 00 latitude, W122 22' 00 longitude<br>N36*39.246' W121*40.121' |
| CLLI Code       | The Common Language Location Identifier (CLLI) that uniquely identifies the geographic location of places and certain functional categories of equipment unique to the telecommunications industry.                                            |
| Number of slots | IOM/CCMCPM/CFMThe number of slots in the system that are available for XCM cards and CPM cards operating as the active or standby CPM.                                                                                                         |
| Number of ports | The total number of ports currently installed in this chassis. This count does not include the Ethernet ports on the CPMs/CFMsCCMs that are used for management access.                                                                        |

## Hardware Commands

| <b>Label</b>                  | <b>Description (Continued)</b>                                                                                                                                   |
|-------------------------------|------------------------------------------------------------------------------------------------------------------------------------------------------------------|
| Critical LED state            | The current state of the Critical LED in this chassis.                                                                                                           |
| Major LED state               | The current state of the Major LED in this chassis.                                                                                                              |
| Minor LED state               | The current state of the Minor LED in this chassis.                                                                                                              |
| Base MAC address              | The base chassis Ethernet MAC address.                                                                                                                           |
| Over Temperature state        | Indicates if there is currently an over temperature condition (OK = not currently over temp)                                                                     |
| Part number                   | The part number of the particular hardware assembly. In the <code>show chassis</code> output, the first set of Hardware Data output is for the chassis midplane. |
| CLEI code                     | The Common Language Equipment Code of the particular hardware assembly.                                                                                          |
| Serial number                 | The serial number of the particular hardware assembly.                                                                                                           |
| Manufacture date              | The manufacture date of the particular hardware assembly.                                                                                                        |
| Manufacturing string          | The factory inputted manufacturing text string for the particular hardware assembly.                                                                             |
| Manufacturing deviations      | Additional manufacturing data.                                                                                                                                   |
| Manufacturing assembly number | Additional manufacturing data.                                                                                                                                   |
| Time of last boot             | The date and time the most recent boot occurred.                                                                                                                 |
| Current alarm state           | Displays the alarm conditions for the specific board.                                                                                                            |
| Number of fan trays           | The total number of fan trays installed in this chassis.                                                                                                         |
| Number of fans                | The total number of fans installed in this chassis.                                                                                                              |
| Fan tray number               | The ID for each fan tray installed in the chassis                                                                                                                |
| Speed                         | Indicates the speed of the fans.                                                                                                                                 |
| Status                        | Current status of the particular hardware assembly.                                                                                                              |
| Number of power supplies      | The number of power supplies installed in the chassis.                                                                                                           |
| Power supply number           | The ID for each power supply installed in the chassis.                                                                                                           |

| Label                 | Description (Continued)                                                                                     |
|-----------------------|-------------------------------------------------------------------------------------------------------------|
| Power supply type     | The basic type of the power supply.                                                                         |
| Power supply model    | The model of the power supply.                                                                              |
| CCM Slot              | The identifier of the CCM (A or B).                                                                         |
| Equipped              | Indicates if the CCM is detected as physically present.                                                     |
| Temperature           | The current temperature detected by the particular hardware assembly.                                       |
| Temperature threshold | The temperature at which the particular hardware assembly considers an over temperature condition to exist. |

### Sample Output

A:Dut-A# show chassis

```

=====
Chassis Information
=====
Name : Dut-A
Type : 7950 XRS-20
Location :
Coordinates :
CLLI code :
Number of slots : 12
Number of ports : 60
Critical LED state : Off
Major LED state : Off
Minor LED state : Off
Over Temperature state : OK
Base MAC address : 24:af:4a:a2:04:c5
Hardware Data
 Part number : xx
 CLEI code : xx
 Serial number : A6113700018
 Manufacture date : xx
 Manufacturing string : (Not Specified)
 Manufacturing deviations : (Not Specified)
 Manufacturing assembly number : xx
 Time of last boot : 2012/05/23 20:26:45
 Current alarm state : alarm cleared

Environment Information

Number of fan trays : 2
Number of fans : xx

Fan tray number : 1
Speed : xx
Status : xx
Hardware Data
 Part number : xx

```

## Hardware Commands

```
CLEI code : xx
Serial number : xx
Manufacture date : xx
Manufacturing string : (Not Specified)
Manufacturing deviations : (Not Specified)
Manufacturing assembly number : xx
Administrative state : up
Operational state : down
Time of last boot : N/A
Current alarm state : alarm cleared

Fan tray number : 2
Speed : xx
Status : not equipped
Hardware Data
 Part number : xx
 CLEI code : xx
 Serial number : xx
 Manufacture date : xx
 Manufacturing string : (Not Specified)
 Manufacturing deviations : (Not Specified)
 Manufacturing assembly number : xx
 Administrative state : up
 Operational state : down
 Time of last boot : N/A
 Current alarm state : alarm cleared

Power Supply Information
 Number of power supplies : 12

Power supply number : 1
Power supply type : dc
Power supply model : peq
Status : xx
Hardware Data
 Part number : xx
 CLEI code : xx
 Serial number : xx
 Manufacture date : xx
 Manufacturing string : (Not Specified)
 Manufacturing deviations : (Not Specified)
 Manufacturing assembly number : xx
 Administrative state : up
 Operational state : down
 Time of last boot : N/A
 Current alarm state : alarm cleared

...

Power supply number : 12
Power supply type : dc
Power supply model : peq
Status : not equipped
Hardware Data
 Part number : xx
 CLEI code : xx
 Serial number : xx
 Manufacture date : xx
 Manufacturing string : (Not Specified)
```

```

Manufacturing deviations : (Not Specified)
Manufacturing assembly number : xx
Administrative state : xx
Operational state : xx
Time of last boot : N/A
Current alarm state : xx

```

```

Chassis Control Module (CCM) Information
```

```

CCM Slot : A
Equipped : yes
Hardware Data
 Part number : 82-0263-01
 CLEI code : xx
 Serial number : AQUA01-52
 Manufacture date : xx
 Manufacturing string : (Not Specified)
 Manufacturing deviations : (Not Specified)
 Manufacturing assembly number : xx
 Administrative state : up
 Operational state : up
 Temperature : 35C
 Temperature threshold : 75C
 Time of last boot : N/A
 Current alarm state : alarm cleared

```

```

CCM Slot : B
Equipped : yes
Hardware Data
 Part number : 82-0263-01
 CLEI code : xx
 Serial number : AQUA01-23
 Manufacture date : xx
 Manufacturing string : (Not Specified)
 Manufacturing deviations : (Not Specified)
 Manufacturing assembly number : xx
 Administrative state : up
 Operational state : up
 Temperature : 34C
 Temperature threshold : 75C
 Time of last boot : N/A
 Current alarm state : alarm cleared

```

```
=====
A:Dut-A#
```

## power-management

**Syntax** `power-management [requirements | utilization] [detail]`

**Context** `show>chassis`

**Description** This command displays power management requirement and utilization information.

**Output**    **Power-management Output Fields** — The following table describes **power-management** output fields:

| Label                         | Description                                                                                                                                    |
|-------------------------------|------------------------------------------------------------------------------------------------------------------------------------------------|
| Power Management Mode         | Specifies the configured power management mode: None, Basic, or Advanced.                                                                      |
| Power Safety Level            | Specifies the configured Power Safety Level, which is a percentage of the worst case power consumption level.                                  |
| Power Safety Alert            | Specifies the configured power level in watts, which causes the system to raise an alarm if the available power level drops below a set level. |
| Power-Zone                    | Specifies the chassis power zone.                                                                                                              |
| Number of PEQs                | Specifies the total number of APEQs installed.                                                                                                 |
| PEQ number:                   | Specifies the APEQ to which the information is associated                                                                                      |
| PEQ Equipped Type             | Specifies the APEQ type installed.                                                                                                             |
| PEQ Provisioned Type          | Specifies the APEQ type provisioned.                                                                                                           |
| Status                        | Specifies the APEQ status.                                                                                                                     |
| Input Feed Status             | Specifies the feed status.                                                                                                                     |
| Hardware Data:                |                                                                                                                                                |
| Part number                   | The APEQ part number.                                                                                                                          |
| CLEI code                     | The APEQ CLEI code.                                                                                                                            |
| Serial number                 | The APEQ serial number.                                                                                                                        |
| Manufacture date              | The date the APEQ was manufactured                                                                                                             |
| Manufacturing deviations      | Specifies any manufacturing deviations.                                                                                                        |
| Manufacturing assembly number | The APEQ assembly number.                                                                                                                      |
| Administrative state          | Specifies the administrative state of the APEQ.                                                                                                |
| Operational state             | Specifies the operational state of the APEQ.                                                                                                   |
| Time of last boot             | Indicates the time stamp of the last system restart.                                                                                           |
| Current alarm state           | Indicates the current alarm state.                                                                                                             |

**Sample Output**

```
*A:Dut-A# show chassis power-management
=====
Chassis Information
```

```
=====
Power Management Information
```

```
Power Management Mode : basic
Power Safety Level : 100%
Power Safety Alert : 0 watts
Power-Zone : 1
Number of PEQs : 12

PEQ number : 1
 PEQ Equipped Type : apeq-dc-2000
 PEQ Provisioned Type : apeq-dc-2000
 Status : shutdown
 Input Feed Status : input B down
 Hardware Data
 Part number : 3HE07114AARA01
 CLEI code : IPUPAJHUAA
 Serial number : NS1250G0116
 Manufacture date : 12202012
 Manufacturing deviations : (Not Specified)
 Manufacturing assembly number : 8205320107
 Administrative state : down
 Operational state : down
 Time of last boot : 2014/01/07 11:01:44
 Current alarm state : alarm active

PEQ number : 2
 PEQ Equipped Type : apeq-dc-2000
 PEQ Provisioned Type : (Not Specified)
 Status : up
 Input Feed Status : input B down
 Hardware Data
 Part number : 3HE07114AARA01
 CLEI code : IPUPAJHUAA
 Serial number : NS1249G0022
 Manufacture date : 12202012
 Manufacturing deviations : (Not Specified)
 Manufacturing assembly number : 8205320107
 Administrative state : up
 Operational state : unprovisioned
 Time of last boot : 2014/01/07 11:01:44
 Current alarm state : alarm active

PEQ number : 3
 PEQ Equipped Type : apeq-dc-2000
 PEQ Provisioned Type : apeq-dc-2000
 Status : up
 Input Feed Status : input B down
 Hardware Data
 Part number : 3HE07114AARA01
 CLEI code : IPUPAJHUAA
 Serial number : NS1250G0141
 Manufacture date : 12202012
 Manufacturing deviations : (Not Specified)
 Manufacturing assembly number : 8205320107
 Administrative state : up
 Operational state : up
 Time of last boot : 2014/01/07 11:01:44
 Current alarm state : alarm active
```

## Hardware Commands

```
PEQ number : 4
PEQ Equipped Type : apeq-dc-2000
PEQ Provisioned Type : apeq-dc-2000
Status : up
Input Feed Status : input B down
Hardware Data
 Part number : 3HE07114AARA01
 CLEI code : IPUPAJHUAA
 Serial number : NS1249G0201
 Manufacture date : 12202012
 Manufacturing deviations : (Not Specified)
 Manufacturing assembly number : 8205320107
 Administrative state : up
 Operational state : up
 Time of last boot : 2014/01/07 11:01:44
 Current alarm state : alarm active

PEQ number : 5
PEQ Equipped Type : apeq-dc-2000
PEQ Provisioned Type : apeq-dc-2000
Status : up
Input Feed Status : input B down
Hardware Data
 Part number : 3HE07114AARA01
 CLEI code : IPUPAJHUAA
 Serial number : NS1250G0123
 Manufacture date : 12202012
 Manufacturing deviations : (Not Specified)
 Manufacturing assembly number : 8205320107
 Administrative state : up
 Operational state : up
 Time of last boot : 2014/01/07 11:01:44
 Current alarm state : alarm active

PEQ number : 6
PEQ Equipped Type : apeq-dc-2000
PEQ Provisioned Type : apeq-dc-2000
Status : up
Input Feed Status : input B down
Hardware Data
 Part number : 3HE07114AARA01
 CLEI code : IPUPAJHUAA
 Serial number : NS1250G0061
 Manufacture date : 12182012
 Manufacturing deviations : (Not Specified)
 Manufacturing assembly number : 8205320107
 Administrative state : up
 Operational state : up
 Time of last boot : 2014/01/07 11:01:44
 Current alarm state : alarm active

PEQ number : 7
PEQ Equipped Type : apeq-dc-2000
PEQ Provisioned Type : apeq-dc-2000
Status : up
Input Feed Status : input B down
Hardware Data
 Part number : 3HE07114AARB01
```

```

CLEI code : IPUPAJHUAA
Serial number : NS13226A310
Manufacture date : 06042013
Manufacturing deviations : (Not Specified)
Manufacturing assembly number : 82-0532-02
Administrative state : up
Operational state : up
Time of last boot : 2014/01/07 11:01:44
Current alarm state : alarm active

PEQ number : 8
PEQ Equipped Type : apeq-dc-2000
PEQ Provisioned Type : apeq-dc-2000
Status : up
Input Feed Status : input B down
Hardware Data
 Part number : 3HE07114AARA01
 CLEI code : IPUPAJHUAA
 Serial number : NS1250G0152
 Manufacture date : 12202012
 Manufacturing deviations : (Not Specified)
 Manufacturing assembly number : 8205320107
 Administrative state : up
 Operational state : up
 Time of last boot : 2014/01/07 11:01:44
 Current alarm state : alarm active

PEQ number : 9
PEQ Equipped Type : apeq-dc-2000
PEQ Provisioned Type : apeq-dc-2000
Status : up
Input Feed Status : input B down
Hardware Data
 Part number : 3HE07114AARA01
 CLEI code : IPUPAJHUAA
 Serial number : NS1250G0122
 Manufacture date : 12202012
 Manufacturing deviations : (Not Specified)
 Manufacturing assembly number : 8205320107
 Administrative state : up
 Operational state : up
 Time of last boot : 2014/01/07 11:01:44
 Current alarm state : alarm active

PEQ number : 10
PEQ Equipped Type : apeq-dc-2000
PEQ Provisioned Type : apeq-dc-2000
Status : up
Input Feed Status : input B down
Hardware Data
 Part number : 3HE07114AARA01
 CLEI code : IPUPAJHUAA
 Serial number : NS1250G0146
 Manufacture date : 12202012
 Manufacturing deviations : (Not Specified)
 Manufacturing assembly number : 8205320107
 Administrative state : up
 Operational state : up
 Time of last boot : 2014/01/07 11:01:44

```

## Hardware Commands

```

Current alarm state : alarm active

PEQ number : 11
PEQ Equipped Type : apeq-dc-2000
PEQ Provisioned Type : apeq-dc-2000
Status : up
Input Feed Status : input B down
Hardware Data
 Part number : 3HE07114AARA01
 CLEI code : IPUPAJHUAA
 Serial number : NS1249G0202
 Manufacture date : 12202012
 Manufacturing deviations : (Not Specified)
 Manufacturing assembly number : 8205320107
 Administrative state : up
 Operational state : up
 Time of last boot : 2014/01/07 11:01:44
 Current alarm state : alarm active

PEQ number : 12
PEQ Equipped Type : apeq-dc-2000
PEQ Provisioned Type : apeq-dc-2000
Status : up
Input Feed Status : input B down
Hardware Data
 Part number : 3HE07114AARA01
 CLEI code : IPUPAJHUAA
 Serial number : NS1250G0115
 Manufacture date : 12202012
 Manufacturing deviations : (Not Specified)
 Manufacturing assembly number : 8205320107
 Administrative state : up
 Operational state : up
 Time of last boot : 2014/01/07 11:01:44
 Current alarm state : alarm active
=====

```

**Output**    **Power-management requirements Output Fields** — he following table describes **power-management requirements** output fields:

| Label          | Description                                                                                                                                    |
|----------------|------------------------------------------------------------------------------------------------------------------------------------------------|
| SUPPLY         |                                                                                                                                                |
| Power Capacity | Indicates the total amount of power available to the chassis.                                                                                  |
| Safety Level   | Specifies the configured Power Safety Level, which is a percentage of the worst case power consumption level.                                  |
| Alert Level    | Specifies the configured power level in watts, which causes the system to raise an alarm if the available power level drops below a set level. |

| Label          | Description                                                           |
|----------------|-----------------------------------------------------------------------|
| REQUIREMENTS   |                                                                       |
| Fan            | Specifies the amount of power required for each fan tray.             |
| IO Module      | Specifies the amount of power required for each IO Module.            |
| CPM Module     | Specifies the amount of power required for each CPM.                  |
| Fabric Module  | Specifies the amount of power required for each SFM.                  |
| MDA Module     | Specifies the amount of power required for each line card.            |
| Total Required | Specifies the total amount of power required for all system elements. |

### Sample Output

```
*A:Dut-A# show chassis power-management requirements
```

```
=====
Chassis Power Requirements
=====
 SUPPLY REQUIREMENTS
Power Capacity : 22000.00 Watts Fan : 1800.00 Watts (8%)
Safety Level : 13203.00 Watts (100%) IO Module : 1395.00 Watts (6%)
Alert Level : 0.00 Watts CPM Module : 408.00 Watts (2%)
 Fabric Module : 1600.00 Watts (7%)
 MDA Module : 7956.00 Watts (36%)
 CCM Module : 44.00 Watts (0%)
 Total Required: 13203.00 Watts (60%)
=====
```

```
*A:Dut-A# show chassis power-management requirements detail
```

```
=====
Chassis Power Requirements (detail)
=====
 SUPPLY REQUIREMENTS
Power Capacity : 22000.00 Watts Fan
Power Supply 1 : 0.00 Watts Fan 1 : 900.00 Watts (4%)
Power Supply 2 : 2000.00 Watts Fan 2 : 900.00 Watts (4%)
Power Supply 3 : 2000.00 Watts IO Module
Power Supply 4 : 2000.00 Watts Slot 1 : 155.00 Watts (1%)
Power Supply 5 : 2000.00 Watts Slot 2 : 155.00 Watts (1%)
Power Supply 6 : 2000.00 Watts Slot 3 : 155.00 Watts (1%)
Power Supply 7 : 2000.00 Watts Slot 5 : 155.00 Watts (1%)
Power Supply 8 : 2000.00 Watts Slot 6 : 155.00 Watts (1%)
Power Supply 9 : 2000.00 Watts Slot 7 : 155.00 Watts (1%)
Power Supply 10 : 2000.00 Watts Slot 8 : 155.00 Watts (1%)
Power Supply 11 : 2000.00 Watts Slot 9 : 155.00 Watts (1%)
Power Supply 12 : 2000.00 Watts Slot 10 : 155.00 Watts (1%)
Safety Level : 13203.00 Watts (100%) CPM Module
```

## Hardware Commands

```

Alert Level : 0.00 Watts
Slot A : 204.00 Watts (1%)
Slot B : 204.00 Watts (1%)
Fabric Module
Sfm 1 : 200.00 Watts (1%)
Sfm 2 : 200.00 Watts (1%)
Sfm 3 : 200.00 Watts (1%)
Sfm 4 : 200.00 Watts (1%)
Sfm 5 : 200.00 Watts (1%)
Sfm 6 : 200.00 Watts (1%)
Sfm 7 : 200.00 Watts (1%)
Sfm 8 : 200.00 Watts (1%)
MDA Module
MDA 1/1 : 452.00 Watts (2%)
MDA 1/2 : 440.00 Watts (2%)
MDA 2/1 : 440.00 Watts (2%)
MDA 2/2 : 440.00 Watts (2%)
MDA 3/1 : 452.00 Watts (2%)
MDA 3/2 : 452.00 Watts (2%)
MDA 5/1 : 440.00 Watts (2%)
MDA 5/2 : 440.00 Watts (2%)
MDA 6/1 : 440.00 Watts (2%)
MDA 6/2 : 440.00 Watts (2%)
MDA 7/1 : 440.00 Watts (2%)
MDA 7/2 : 440.00 Watts (2%)
MDA 8/1 : 440.00 Watts (2%)
MDA 8/2 : 440.00 Watts (2%)
MDA 9/1 : 440.00 Watts (2%)
MDA 9/2 : 440.00 Watts (2%)
MDA 10/1 : 440.00 Watts (2%)
MDA 10/2 : 440.00 Watts (2%)
CCM Module
CCM 1 : 22.00 Watts (0%)
CCM 2 : 22.00 Watts (0%)
Total Required: 13203.00 Watts (60%)
=====

```

**Output Power-management utilization Output Fields** — the following table describes **power-management utilization** output fields:

| Label          | Description                                                                                                                                    |
|----------------|------------------------------------------------------------------------------------------------------------------------------------------------|
| SUPPLY         |                                                                                                                                                |
| Power Capacity | Indicates the total amount of power available to the chassis.                                                                                  |
| Safety Level   | Specifies the configured Power Safety Level, which is a percentage of the worst case power consumption level.                                  |
| Alert Level    | Specifies the configured power level in watts, which causes the system to raise an alarm if the available power level drops below a set level. |
| DEMAND         |                                                                                                                                                |
| Fan            | Specifies the amount of power utilized for the fan tray indicated.                                                                             |
| IO Module      | Specifies the amount of power utilized for the IO Module indicated.                                                                            |
| CPM Module     | Specifies the amount of power utilized for the CPM indicated.                                                                                  |

| Label         | Description                                                           |
|---------------|-----------------------------------------------------------------------|
| Fabric Module | Specifies the amount of power utilized for the SFM indicated.         |
| MDA Module    | Specifies the amount of power utilized for the line card indicated.   |
| Current Util. | Specifies the total amount of power utilized for all system elements. |
| Peak Util.    | Specifies peak utilization starting from boot up.                     |

### Sample Output

```
*A:Dut-A# show chassis power-management utilization
```

```
=====
Chassis Power Utilization
=====
```

| SUPPLY         |                         | PEAK DEMAND    |                         |
|----------------|-------------------------|----------------|-------------------------|
| Power Capacity | : 22000.00 Watts        | Fan            | : 695.00 Watts ( 3%)    |
| Safety Level   | : 13203.00 Watts (100%) | IO Module      | : 7163.09 Watts ( 33%)  |
| Alert Level    | : 0.00 Watts            | CPM Module     | : 392.86 Watts ( 2%)    |
|                |                         | Fabric Module  | : 1622.25 Watts ( 7%)   |
|                |                         | MDA Module     | : 6023.07 Watts ( 27%)+ |
|                |                         | CCM Module     | : 50.82 Watts ( 0%)     |
|                |                         | Peak Util.     | : 9924.02 Watts ( 45%)  |
|                |                         | CURRENT DEMAND |                         |
|                |                         | Current Util.  | : 9623.01 Watts ( 44%)  |

```
+ Power utilization of device already included in IO Module value
```

```
*A:Dut-A# show chassis power-management utilization detail
```

```
=====
Chassis Power Utilization (detail)
=====
```

| SUPPLY          |                         | PEAK DEMAND   |                      |
|-----------------|-------------------------|---------------|----------------------|
| Power Capacity  | : 22000.00 Watts        | Fan           |                      |
| Power Supply 1  | : 0.00 Watts            | Fan 1         | : 324.00 Watts ( 1%) |
| Power Supply 2  | : 2000.00 Watts         | Fan 2         | : 371.00 Watts ( 2%) |
| Power Supply 3  | : 2000.00 Watts         | IO Module     |                      |
| Power Supply 4  | : 2000.00 Watts         | Slot 1        | : 812.19 Watts ( 4%) |
| Power Supply 5  | : 2000.00 Watts         | Slot 2        | : 784.18 Watts ( 4%) |
| Power Supply 6  | : 2000.00 Watts         | Slot 3        | : 799.01 Watts ( 4%) |
| Power Supply 7  | : 2000.00 Watts         | Slot 5        | : 797.36 Watts ( 4%) |
| Power Supply 8  | : 2000.00 Watts         | Slot 6        | : 797.36 Watts ( 4%) |
| Power Supply 9  | : 2000.00 Watts         | Slot 7        | : 794.07 Watts ( 4%) |
| Power Supply 10 | : 2000.00 Watts         | Slot 8        | : 792.42 Watts ( 4%) |
| Power Supply 11 | : 2000.00 Watts         | Slot 9        | : 795.72 Watts ( 4%) |
| Power Supply 12 | : 2000.00 Watts         | Slot 10       | : 790.77 Watts ( 4%) |
| Safety Level    | : 13203.00 Watts (100%) | CPM Module    |                      |
| Alert Level     | : 0.00 Watts            | Slot A        | : 197.12 Watts ( 1%) |
|                 |                         | Slot B        | : 195.74 Watts ( 1%) |
|                 |                         | Fabric Module |                      |
|                 |                         | Sfm 1         | : 201.92 Watts ( 1%) |
|                 |                         | Sfm 2         | : 203.30 Watts ( 1%) |
|                 |                         | Sfm 3         | : 205.36 Watts ( 1%) |
|                 |                         | Sfm 4         | : 201.92 Watts ( 1%) |

## Hardware Commands

```

Sfm 5 : 201.24 Watts (1%)
Sfm 6 : 203.98 Watts (1%)
Sfm 7 : 202.61 Watts (1%)
Sfm 8 : 201.92 Watts (1%)
MDA Module
MDA 1/1 : 342.86 Watts (2%)+
MDA 1/2 : 334.06 Watts (2%)+
MDA 2/1 : 330.77 Watts (2%)+
MDA 2/2 : 331.87 Watts (2%)+
MDA 3/1 : 335.16 Watts (2%)+
MDA 3/2 : 343.96 Watts (2%)+
MDA 5/1 : 331.87 Watts (2%)+
MDA 5/2 : 326.37 Watts (1%)+
MDA 6/1 : 336.26 Watts (2%)+
MDA 6/2 : 332.97 Watts (2%)+
MDA 7/1 : 339.56 Watts (2%)+
MDA 7/2 : 332.97 Watts (2%)+
MDA 8/1 : 339.56 Watts (2%)+
MDA 8/2 : 328.57 Watts (1%)+
MDA 9/1 : 336.26 Watts (2%)+
MDA 9/2 : 331.87 Watts (2%)+
MDA 10/1 : 336.26 Watts (2%)+
MDA 10/2 : 332.97 Watts (2%)+
CCM Module
CCM 1 : 24.73 Watts (0%)
CCM 2 : 26.10 Watts (0%)
Peak Util. : 9924.02 Watts (45%)
 CURRENT DEMAND
Current Util. : 9613.68 Watts (44%)
=====

```

+ Power utilization of device already included in IO Module value

\*A:Dut-A# show chassis power-management requirements

### Chassis Power Requirements

```

=====
SUPPLY REQUIREMENTS
Power Capacity : 22000.00 Watts Fan : 1800.00 Watts (8%)
Safety Level : 13203.00 Watts (100%) IO Module : 1395.00 Watts (6%)
Alert Level : 0.00 Watts CPM Module : 408.00 Watts (2%)
 Fabric Module : 1600.00 Watts (7%)
 MDA Module : 7956.00 Watts (36%)
 CCM Module : 44.00 Watts (0%)
 Total Required: 13203.00 Watts (60%)
=====

```

## card

**Syntax** `card [slot-number] [detail]`  
**card state**  
`card slot-number [card] fp [1..2] ingress queue-group queue-group-name instance [1..65535]`  
**mode** {access|network} [statistics]

**Context** show

**Description** This command displays (XCM) card information.  
If no command line parameters are specified, a card summary for all cards is displayed.

**Parameters** *slot-number* — Displays information for the specified card slot.

**Default** Displays all cards.

**Values** XCM slots are numbered from 1 - 10  
CPM slots are A, B (upper or lowercase)  
SFM slots are not addressed as cards. See `show sfm` command.

**state** — Displays provisioned and equipped card and MDA information.

**detail** — Displays detailed card information.

**Default** Displays summary information only.

**Output** **Show Card Output** — The following table describes show card output fields.

| Label             | Description                                                                                        |
|-------------------|----------------------------------------------------------------------------------------------------|
| Slot              | The slot number of the card in the chassis.                                                        |
| Provisioned type  | The card type that is configured for the slot.                                                     |
| Equipped type     | The card type that is actually populated in the slot.                                              |
| Admin State       | Up — The card is administratively up.<br>Down — The card is administratively down (e.g., shutdown) |
| Operational State | Up — The card is operationally up.<br>Down — The card is operationally down.                       |

### Sample Output

```
A:Dut-A# show card
=====
Card Summary
=====
Slot Provisioned Type Admin Operational Comments
 Equipped Type (if different) State State

1 xcm-x20 up up
2 xcm-x20 up up
A cpm-x20 up up/active
B cpm-x20 up up/standby
=====

A:Dut-A# show card 1 detail
```

## Hardware Commands

```
=====
Card 1
=====
Slot Provisioned Type Admin Operational Comments
 Equipped Type (if different) State State

1 xcm-x20 up up

IOM Card Specific Data
 Clock source : none
 Named Pool Mode : Disabled
 Fail On Error : Disabled
 Available MDA slots : 2
 Installed MDAs : 2

FP 1 Specific Data
 WRED Admin State : Out Of Service
 WRED buffer-allocation max : 2500
 WRED buffer-allocation min : 2500
 WRED reserved-cbs max : 2500
 WRED reserved-cbs min : 2500
 WRED Slope Policy : default
 hi-bw-mc-srcEgress Alarm : 2
 hi-bw-mc-srcEgress Group : 0
 mc-path-mgmt Admin State : Out Of Service
 Ingress Bandwidth Policy : default

FP 2 Specific Data
 WRED Admin State : Out Of Service
 WRED buffer-allocation max : 2500
 WRED buffer-allocation min : 2500
 WRED reserved-cbs max : 2500
 WRED reserved-cbs min : 2500
 WRED Slope Policy : default
 hi-bw-mc-srcEgress Alarm : 2
 hi-bw-mc-srcEgress Group : 0
 mc-path-mgmt Admin State : Out Of Service
 Ingress Bandwidth Policy : default

Hardware Data
 Platform type : 7950
 Part number :
 CLEI code :
 Serial number : xx
 Manufacture date :
 Manufacturing string : (Not Specified)
 Manufacturing deviations : (Not Specified)
 Manufacturing assembly number : 82-0334-02
 Administrative state : up
 Operational state : up
 Temperature : 45C
 Temperature threshold : 75C
 Software boot (rom) version : X-0.0.I3326 on Thu May 10 18:22:55 PDT
 2012 by builder
 Software version : TiMOS-I-10.0.S209 iom/hops ALCATEL XRS 795*
 Time of last boot : 2012/05/23 20:27:09
 Current alarm state : alarm cleared
 Base MAC address : 00:21:05:8a:ca:0b
```

```

Last bootup reason : hard boot
Memory capacity : 4,096 MB
* indicates that the corresponding row element may have been truncated.
=====
A:Dut-A#

```

**Show Card State Output** — The following table describes show card state output fields.

| Label             | Description                                                                                                          |
|-------------------|----------------------------------------------------------------------------------------------------------------------|
| Slot/MDA          | The slot number of the card in the chassis.                                                                          |
| Provisioned Type  | The card type that is configured for the slot.                                                                       |
| Equipped Type     | The card type that is actually populated in the slot.                                                                |
| Admin State       | Up — The card is administratively up.<br>Down — The card is administratively down.                                   |
| Operational State | Up — The card is operationally up.<br><br>provisioned — There is no card in the slot but it has been pre-configured. |
| Num Ports         | The number of ports available on the MDA.                                                                            |
| Num MDA           | The number of MDAs installed.                                                                                        |
| Comments          | Indicates whether the SF/CPM is the active or standby.                                                               |

### Sample Output

```

A:Dut-A# show card state
=====
Card State
=====
Slot/ Provisioned Type Admin Operational Num Num Comments
Id Equipped Type (if different) State State Ports MDA

1 xcm-x20 up up 2
1/1 cx20-10g-sfp up up 20
1/2 cx20-10g-sfp up up 20
2 xcm-x20 up up 2
2/1 cx20-10g-sfp up up 20
A cpm-x20 up up Active
B cpm-x20 up up Standby
=====

```

**Show Card Detail Output** — The following table describes detailed card output fields.

| Label                    | Description                                                                                                                         |
|--------------------------|-------------------------------------------------------------------------------------------------------------------------------------|
| Clock source             | Source of clock for the IOM. Note: Currently this parameter always displays 'none'                                                  |
| Available MDA slots      | The number of MDA slots available on the IOM.                                                                                       |
| Installed MDAs           | The number of MDAs installed on the IOM                                                                                             |
| Part number              | The IOM part number.                                                                                                                |
| CLEI code                | The Common Language Location Identifier (CLLI) code string for the router.                                                          |
| Serial number            | The serial number. Not user modifiable.                                                                                             |
| Manufacture date         | The chassis manufacture date. Not user modifiable.                                                                                  |
| Manufacturing string     | Factory-inputted manufacturing text string. Not user modifiable.                                                                    |
| Manufacturing deviations | Displays a record of changes by manufacturing to the hardware or software and which is outside the normal revision control process. |
| Administrative state     | Up — The card is administratively up.                                                                                               |
|                          | Down — The card is administratively down.                                                                                           |
| Operational state        | Up — The card is operationally up.                                                                                                  |
|                          | Down — The card is operationally down.                                                                                              |
| Temperature              | Internal chassis temperature.                                                                                                       |
| Temperature threshold    | The value above which the internal temperature must rise in order to indicate that the temperature is critical.                     |
| Software boot version    | The version of the boot image.                                                                                                      |
| Software version         | The software version number.                                                                                                        |
| Time of last boot        | The date and time the most recent boot occurred.                                                                                    |
| Current alarm state      | Displays the alarm conditions for the specific board.                                                                               |
| Base MAC address         | Displays the base MAC address of the hardware component.                                                                            |
| Memory Capacity          | Displays the memory capacity of the card.                                                                                           |

## Sample Output

```
A:Dut-A# show card 10 detail
=====
Card 10
=====
Slot Provisioned Equipped Admin Operational Comments
 Card-type Card-type State State

10 iom3-xp iom3-xp up up

IOM Card Specific Data
 Clock source : none
 Named Pool Mode : Disabled
 Fail On Error : Disabled
 Available MDA slots : 2
 Installed MDAs : 1

FP 1 Specific Data
 WRED Admin State : Out Of Service
 WRED buffer-allocation max : 2500
 WRED buffer-allocation min : 2500
 WRED reserved-cbs max : 2500
 WRED reserved-cbs min : 2500
 WRED Slope Policy : default
 hi-bw-mc-srcEgress Alarm : 2
 hi-bw-mc-srcEgress Group : 0
 mc-path-mgmt Admin State : Out Of Service
 Ingress Bandwidth Policy : default

Hardware Data
 Platform type : 7750
 Part number : 3HE03619AAAK01
 CLEI code : IPU3AC9EAA
 Serial number : NS1112F0955
 Manufacture date : 03182011
 Manufacturing string :
 Manufacturing deviations :
 Manufacturing assembly number : 82-0107-09
 Administrative state : up
 Operational state : up
 Temperature : 50C
 Temperature threshold : 75C
 Software boot (rom) version : X-0.0.I3122 on Mon Oct 17 18:16:02 PDT 2011*
 Software version : TiMOS-I-8.0.B1-250 iom/hops ALCATEL SR 7750*
 Time of last boot : 2011/11/15 08:44:52
 Current alarm state : alarm cleared
 Base MAC address : 8c:90:d3:a4:fb:33
 Last bootup reason : hard boot
 Memory capacity : 2,048 MB
```

```
A:Dut-A# show card 1 detail
=====
Card 1
=====
Slot Provisioned Type Admin Operational Comments
 Equipped Type (if different) State State

```

## Hardware Commands

```
1 xcm-x20 up up

IOM Card Specific Data
 Clock source : none
 Named Pool Mode : Disabled
 Fail On Error : Disabled
 Available MDA slots : 2
 Installed MDAs : 2

FP 1 Specific Data
 WRED Admin State : Out Of Service
 WRED buffer-allocation max : 2500
 WRED buffer-allocation min : 2500
 WRED reserved-cbs max : 2500
 WRED reserved-cbs min : 2500
 WRED Slope Policy : default
 hi-bw-mc-srcEgress Alarm : 2
 hi-bw-mc-srcEgress Group : 0
 mc-path-mgmt Admin State : Out Of Service
 Ingress Bandwidth Policy : default

FP 2 Specific Data
 WRED Admin State : Out Of Service
 WRED buffer-allocation max : 2500
 WRED buffer-allocation min : 2500
 WRED reserved-cbs max : 2500
 WRED reserved-cbs min : 2500
 WRED Slope Policy : default
 hi-bw-mc-srcEgress Alarm : 2
 hi-bw-mc-srcEgress Group : 0
 mc-path-mgmt Admin State : Out Of Service
 Ingress Bandwidth Policy : default

Hardware Data
 Platform type : 7950
 Part number :
 CLEI code :
 Serial number : xx
 Manufacture date :
 Manufacturing string : (Not Specified)
 Manufacturing deviations : (Not Specified)
 Manufacturing assembly number : 82-0334-02
 Administrative state : up
 Operational state : up
 Temperature : 45C
 Temperature threshold : 75C
 Software boot (rom) version : X-0.0.I3326 on Thu May 10 18:22:55 PDT
 2012 by builder
 Software version : TiMOS-I-10.0.S209 iom/hops ALCATEL XRS 795*
 Time of last boot : 2012/05/23 20:27:09
 Current alarm state : alarm cleared
 Base MAC address : 00:21:05:8a:ca:0b
 Last bootup reason : hard boot
 Memory capacity : 4,096 MB

* indicates that the corresponding row element may have been truncated.
=====
A:Dut-A#
```

**CPM Output** — The following table describes the output fields for a CPM card.

| Label                     | Description                                                                                                                                                          |
|---------------------------|----------------------------------------------------------------------------------------------------------------------------------------------------------------------|
| Slot                      | The slot of the card in the chassis.                                                                                                                                 |
| Card Provisioned          | The SF/CPM type that is configured for the slot.                                                                                                                     |
| Card Equipped             | The SF/CPM type that is actually populated in the slot.                                                                                                              |
| Admin State               | Up — The SF/CPM is administratively up.<br>Down — The SF/CPM is administratively down.                                                                               |
| Operational State         | Up — The SF/CPM is operationally up.<br>Down — The SF/CPM is operationally down.                                                                                     |
| BOF last modified         | The date and time of the most recent BOF modification.                                                                                                               |
| Config file version       | The configuration file version.                                                                                                                                      |
| Config file last modified | The date and time of the most recent config file modification.                                                                                                       |
| Config file last modified | The date and time of the most recent config file modification.                                                                                                       |
| Config file last saved    | The date and time of the most recent config file save.                                                                                                               |
| CPM card status           | active — The card is acting as the primary (active) CPM in a redundant system.<br>standby — The card is acting as the standby (secondary) CPM in a redundant system. |
| Administrative state      | Up — The CPM is administratively up.<br>Down — The CPM is administratively down.                                                                                     |
| Operational state         | Up — The CPM is operationally up.<br>Down — The CPM is operationally down.                                                                                           |
| Serial number             | The compact flash part number. Not user modifiable.                                                                                                                  |
| Firmware revision         | The firmware version. Not user modifiable.                                                                                                                           |
| Model number              | The compact flash model number. Not user modifiable.                                                                                                                 |
| Size                      | The amount of space available on the compact flash card.                                                                                                             |
| Free space                | The amount of space remaining on the compact flash card.                                                                                                             |

## Hardware Commands

| Label                 | Description (Continued)                                                                                         |
|-----------------------|-----------------------------------------------------------------------------------------------------------------|
| Part number           | The SF/CPM part number.                                                                                         |
| CLEI code             | The code used to identify the router.                                                                           |
| Serial number         | The SF/CPM part number. Not user modifiable.                                                                    |
| Manufacture date      | The chassis manufacture date. Not user modifiable.                                                              |
| Manufacturing string  | Factory-inputted manufacturing text string. Not user modifiable.                                                |
| Administrative state  | Up – The card is administratively up.<br>Down – The card is administratively down.                              |
| Operational state     | Up – The card is operationally up.<br>Down – The card is operationally down.                                    |
| Time of last boot     | The date and time the most recent boot occurred.                                                                |
| Current alarm state   | Displays the alarm conditions for the specific board.                                                           |
| Status                | Displays the current status.                                                                                    |
| Temperature           | Internal chassis temperature.                                                                                   |
| Temperature threshold | The value above which the internal temperature must rise in order to indicate that the temperature is critical. |
| Software boot version | The version of the boot image.                                                                                  |
| Memory capacity       | The total amount of memory.                                                                                     |

### Sample Output

```

B:NS082761964# show card B detail
=====
Card B
=====
Slot Provisioned Equipped Admin Operational Comments
 Card-type Card-type State State

B sfm3-12 sfm3-12 up up/active
BOF last modified : N/A
Config file version : WED AUG 11 19:33:06 2010 UTC
Config file last modified : N/A
Config file last saved : N/A
M/S clocking ref state : primary

Flash - cf1:
 Administrative State : up

```

```

Operational state : not equipped

Flash - cf2:
 Administrative State : up
 Operational state : not equipped

Flash - cf3:
 Administrative State : up
 Operational state : up
 Serial number : 365ST295S3453SC01311
 Firmware revision : V2.23
 Model number : SILICONSYSTEMS INC 256MB
 Size : 253,932 KB
 Free space : 121,368 KB

Hardware Data
 Platform type : 7750
 Part number : 3HE03617AAAA01
 CLEI code : IPUCAN4FAA
 Serial number : NS987456321
 Manufacture date : 05072010
 Manufacturing string :
 Manufacturing deviations :
 Manufacturing assembly number :
 Administrative state : up
 Operational state : up
 Temperature : 34C
 Temperature threshold : 75C
 Software boot (rom) version : X-0.0.I2627 on Thu Jun 10 18:03:16 PDT 2010*
 Software version : TiMOS-C-0.0.private cpm/hops ALCATEL SR 775*
 Time of last boot : 2010/08/24 13:07:56
 Current alarm state : alarm cleared
 Base MAC address : 00:03:fa:1b:d7:16
 Memory capacity : 4,096 MB
 System timing oscillator type : OCXO
=====

```

**PW Shaping Feature Output**

```

*A:Dut-T# show card 9 fp 1 ingress queue-group "QGIngl" mode network instance 1 statistics
=====
Card:9 Net.QGrp: QGIngl Instance: 1
=====
Group Name : QGIngl
Description : (Not Specified)
Pol Ctl Pol : pcp Acct Pol : None
Collect Stats : disabled

Statistics

 Packets Octets

Ing. Policer: 1 Grp: QGIngl (Stats mode: minimal)
Off. All : 91836202 91465530792
Dro. All : 6678807 6649127172
For. All : 85157395 84816403620

Ing. Policer: 2 Grp: QGIngl (Stats mode: minimal)

```

## Hardware Commands

|                                                    |   |          |             |
|----------------------------------------------------|---|----------|-------------|
| Off. All                                           | : | 93584703 | 90933906888 |
| Dro. All                                           | : | 8320200  | 6106644900  |
| For. All                                           | : | 85264503 | 84827261988 |
| Ing. Policer: 3 Grp: QGIngl (Stats mode: minimal)  |   |          |             |
| Off. All                                           | : | 93584703 | 90933906888 |
| Dro. All                                           | : | 8320049  | 6106288404  |
| For. All                                           | : | 85264654 | 84827618484 |
| Ing. Policer: 4 Grp: QGIngl (Stats mode: minimal)  |   |          |             |
| Off. All                                           | : | 93584703 | 90933906888 |
| Dro. All                                           | : | 8326509  | 6110568864  |
| For. All                                           | : | 85258194 | 84823338024 |
| Ing. Policer: 5 Grp: QGIngl (Stats mode: minimal)  |   |          |             |
| Off. All                                           | : | 93584703 | 90933906888 |
| Dro. All                                           | : | 24877143 | 22616873028 |
| For. All                                           | : | 68707560 | 68317033860 |
| Ing. Policer: 6 Grp: QGIngl (Stats mode: minimal)  |   |          |             |
| Off. All                                           | : | 93434643 | 90919501128 |
| Dro. All                                           | : | 24727111 | 22602499656 |
| For. All                                           | : | 68707532 | 68317001472 |
| Ing. Policer: 7 Grp: QGIngl (Stats mode: minimal)  |   |          |             |
| Off. All                                           | : | 93584703 | 90933906888 |
| Dro. All                                           | : | 24877214 | 22616941944 |
| For. All                                           | : | 68707489 | 68316964944 |
| Ing. Policer: 8 Grp: QGIngl (Stats mode: minimal)  |   |          |             |
| Off. All                                           | : | 93430663 | 90919119048 |
| Dro. All                                           | : | 24723280 | 22602263280 |
| For. All                                           | : | 68707383 | 68316855768 |
| Ing. Policer: 9 Grp: QGIngl (Stats mode: minimal)  |   |          |             |
| Off. All                                           | : | 0        | 0           |
| Dro. All                                           | : | 0        | 0           |
| For. All                                           | : | 0        | 0           |
| Ing. Policer: 10 Grp: QGIngl (Stats mode: minimal) |   |          |             |
| Off. All                                           | : | 0        | 0           |
| Dro. All                                           | : | 0        | 0           |
| For. All                                           | : | 0        | 0           |
| Ing. Policer: 11 Grp: QGIngl (Stats mode: minimal) |   |          |             |
| Off. All                                           | : | 0        | 0           |
| Dro. All                                           | : | 0        | 0           |
| For. All                                           | : | 0        | 0           |
| Ing. Policer: 12 Grp: QGIngl (Stats mode: minimal) |   |          |             |
| Off. All                                           | : | 0        | 0           |
| Dro. All                                           | : | 0        | 0           |
| For. All                                           | : | 0        | 0           |
| Ing. Policer: 13 Grp: QGIngl (Stats mode: minimal) |   |          |             |
| Off. All                                           | : | 0        | 0           |
| Dro. All                                           | : | 0        | 0           |
| For. All                                           | : | 0        | 0           |

```

Ing. Policer: 14 Grp: QGIngl (Stats mode: minimal)
Off. All : 0 0
Dro. All : 0 0
For. All : 0 0

```

```

Ing. Policer: 15 Grp: QGIngl (Stats mode: minimal)
Off. All : 0 0
Dro. All : 0 0
For. All : 0 0

```

```

Ing. Policer: 16 Grp: QGIngl (Stats mode: minimal)
Off. All : 0 0
Dro. All : 0 0
For. All : 0 0

```

```

=====
*A:Dut-T#

```

## cflowd

### Syntax

## elmi

**Syntax** elmi

**Context** show

**Description** This command displays Ethernet Link Management Interface (eLMI) information.

**ELMI Output** — The following table describes eLMI output fields.

| Field         | Description                                                                                                                                          |
|---------------|------------------------------------------------------------------------------------------------------------------------------------------------------|
| Link Status   | Status of the E-LMI protocol when the elmi mode is set to uni-n. Link Status will indicate up if eLMI mode is set to "none".                         |
| T391          | pooling timer used by UNI-C. UNI-N will send the consecutive single EVC asynchronous status messages every (T391/10) rounded to the second interval. |
| T392          | Pooling verification timer for UNI-N                                                                                                                 |
| N393          | Status counter for UNI-N                                                                                                                             |
| Rx Enq. Time  | Last time when a status enquiry message was received from UNI-C.                                                                                     |
| Rx Enq Msg    | Number of status enquiry messages received.                                                                                                          |
| Rx Check Time | Last time when a status enquiry E-LMI check message was received.                                                                                    |

| Field               | Description                                                                |
|---------------------|----------------------------------------------------------------------------|
| Rx Inv. SeqNum      | Counts the number of E-LMI messages received with invalid sequence number. |
| Enq Timeouts        | Counts the number of T392 timer expired.                                   |
| Tx Status Time      | Last time when a status message was sent by UNI-N.                         |
| Tx Status Msg       | Number of status messages sent by UNI-N.                                   |
| Tx Check Time       | Last time when a status eLMI check message was sent by UNI-N.              |
| Tx Async Status Msg | Counter for single EVC asynchronous status messages sent by UNI-N.         |
| Discard Msg         | Counter for the status enquiry messages discarded due to errors.           |

**EVC**

**Syntax** `evc [port-id [vlan vlan-id]]`

**Context** `show>elmi`

**Description** This command displays Ethernet Virtual Connections (EVC). No argument displays all the EVC on the service router. The port and VLAN arguments display information related to EVC associated with the port and VLAN.

**Parameters** *port-id* — Displays information related to the EVCs configured on the port

**Values** slot/mda/port

*vlan vlan-id* — Specifies the VLAN Identifier of the EVC.

**Values** 0 — 4094, \*

**Sample Output**

```
*A:Dut-C# show elmi evc
=====
ELMI EVC Table
=====
Port Vlan Status Type Evc Id

1/1/1 10 New-Act P2p EVC11110
1/1/3 30 New-Act P2p EVC11220
1/1/5 100 Act P2p EVC115100
1/1/5 200 Act P2p EVC115200

Number of Evcs : 4
=====
*A:Dut-C#
```

```
A:Dut-C# show elmi evc 1/1/5
=====
ELMI EVC Table
=====
Port Vlan Status Type Evc Id

1/1/5 100 Act P2p EVC115100
1/1/5 200 Act P2p EVC115200

Number of Evcs : 2
=====
A:Dut-C#
```

```
*A:Dut-C# show elmi evc 1/1/5 vlan 100
=====
Evc Detailed Information
=====
Port : 1/1/5 vlanId : 100
Evc Status : Act Evc Type : P2p
Evc Identifier: EVC115100
=====
*A:Dut-C#
```

## uni

**Syntax** `uni [port-id]`

**Context** `show>elmi`

**Description** This command displays information about ELMI (mode, status, number of EVCs (SAPs) configure on the port for all the ports on the service router.

**Parameters** *port-id* — Displays UNI information for the specified port.

### Sample Output

```
*A:Dut-C# show elmi uni
=====
ELMI UNI-N Table
=====
Port Mode Status #Evcs Uni Identifier

1/1/1 None Up 0 10/100 Ethernet TX
1/1/2 None Up 0 port-21
1/1/3 None Up 0 10/100 Ethernet TX
1/1/4 None Up 0 10/100 Ethernet TX
1/1/5 Uni-N Up 2 UNI115
1/1/6 None Up 0 10/100 Ethernet TX
1/1/7 None Up 0 10/100 Ethernet TX
1/1/8 None Up 0 10/100 Ethernet TX
1/1/9 None Up 0 10/100 Ethernet TX
1/1/10 None Up 0 10/100 Ethernet TX
1/1/11 None Up 0 10/100 Ethernet TX
1/1/12 None Up 0 10/100 Ethernet TX
```

## Hardware Commands

```
1/1/13 None Up 0 10/100 Ethernet TX
1/1/14 None Up 0 10/100 Ethernet TX
1/1/15 None Up 0 10/100 Ethernet TX
1/1/16 None Up 0 10/100 Ethernet TX
1/1/17 None Up 0 10/100 Ethernet TX
...
=====
*A:Dut-C#

*A:Dut-C# show elmi uni 1/1/5
=====
Uni-N Detailed Information
=====
Uni Mode : Uni-N Link Status : Up
Uni Identifier: UNI115
T391 : 10 seconds T392 : 15 seconds
N393 : 4 UniType : Bundling
Rx Enq. Time : 02/18/2010 17:11:44 Tx Status Time : 02/18/2010 17:11:44
Rx Enq Msg : 24 Tx Status Msg : 24
Rx Check Time : 02/18/2010 17:12:34 Tx Check Time : 02/18/2010 17:12:34
Rx Inv. SeqNum: 0 Tx Async Status Msg : 0
Enq Timeouts : 0 Discard Msg : 0
=====
*A:Dut-C#
```

## interface-group-handler

**Syntax** `interface-group-handler [igh-id]`

**Context** show

**Description** This command displays Interface Group Handler (IGH) information.  
If no command line options are specified, a summary listing of all IGHs is displayed.

**Parameters** *igh-id* — Displays information only on the specified IGH ID.

### Sample

```
A:ALU-27# show interface-group-handler
=====
Interface Group Handler Summary Information
=====
IGH Index Admin Number of Threshold
 State Members

1 Up 4 4
2 Up 2 2
=====
A:ALU-27#

A:ALU-27#show interface-group-handler 2
=====
```

```

Interface Group Handler 2 Information
=====
Admin Status : Up
Threshold : 2
Last Change : 02/02/2010 18:10:04

Interface Group Handler Protocol Information

Protocol Oper Status Active Links Up Time

ipcp up 2 0d 00:15:04
ipv6cp none 0 N/A
mplscp waiting 0 N/A
osicp none 0 N/A

Port 1/5/2.2 Information

Protocol Oper Status Up Time

ipcp up 0d 00:15:05
ipv6cp none N/A
mplscp running N/A
osicp none N/A

Port 1/5/2.3 Information

Protocol Oper Status Up Time

ipcp up 0d 00:15:05
ipv6cp none N/A
mplscp running N/A
osicp none N/A
=====
A:ALU-27#

```

## mda

**Syntax** `mda [slot [/mda]] [detail]`

**Context** show

**Description** This command displays MDA (XMA) information.

If no command line options are specified, a summary output of all MDAs is displayed in table format.

**Parameters** *slot* — The slot number for which to display MDA information.

**Values** 1 — 10

*mda* — The MDA number in the slot for which to display MDA information.

1, 2

**detail** — Displays detailed MDA information.

**Output**    **MDA Output** — The following table describes MDA output fields.

| Label             | Description                                                                 |
|-------------------|-----------------------------------------------------------------------------|
| Slot              | The chassis slot number.                                                    |
| MDA               | The MDA slot number.                                                        |
| Provisionedtype   | The MDA type provisioned.                                                   |
| Equippedtype      | The MDA type actually installed.                                            |
| Admin State       | Up — Administratively up.<br>Down — Administratively down (e.g., shutdown). |
| Operational State | Up — Operationally up.<br>Down — Operationally down.                        |

**Sample Output**

```
A:Dut-A# show mda

=====
MDA Summary
=====
Slot Mda Provisioned Type Admin Operational
 Mda Equipped Type (if different) State State

1 1 cx20-10g-sfp up up
 2 cx20-10g-sfp up up
2 1 cx20-10g-sfp up up
=====
A:Dut-A#
```

**MDA Detailed Output** — The following table describes detailed MDA output fields.

| Label                        | Description                                                                      |
|------------------------------|----------------------------------------------------------------------------------|
| Slot                         | The chassis slot number.                                                         |
| Slot                         | The MDA slot number.                                                             |
| Provisioned Provisioned-type | The provisioned MDA type.                                                        |
| Equipped Mda-type            | The MDA type that is physically inserted into this slot in this chassis.         |
| Admin State                  | Up — The MDA is administratively up.<br>Down — The MDA is administratively down. |

| Label                        | Description (Continued)                                                                                 |
|------------------------------|---------------------------------------------------------------------------------------------------------|
| Operational State            | Up – The MDA is operationally up.                                                                       |
|                              | Down – The MDA is operationally down.                                                                   |
| Failure Reason               | This hardware component has failed.                                                                     |
| Maximum port count           | The maximum number of ports that can be equipped on the MDA card.                                       |
| Number of ports equipped     | The number of ports that are actually equipped on the MDA.                                              |
| Transmit timing selected     | Indicates the source for the timing used by the MDA.                                                    |
| Sync interface timing status | Indicates whether the MDA has qualified one of the timing signals from the CPMs.                        |
| Network Ingress Queue Policy | Specifies the network queue policy applied to the MDA to define the queueing structure for this object. |
| Capabilities                 | Specifies the minimum size of the port that can exist on the MDA.                                       |
| Egress XPL error threshold   | The Egress XPL Error Threshold value used by the <b>fail-on-error</b> feature.                          |
| Egress XPL error window      | The Egress XPL Error Window value used by the <b>fail-on-error</b> feature.                             |
| Max channel size             | Specifies the maximum size of the channel that can exist on the channelized MDA.                        |
| Part number                  | The hardware part number.                                                                               |
| CLEI code                    | The code used to identify the MDA.                                                                      |
| Serial number                | The MDA part number. Not user modifiable.                                                               |
| Manufacture date             | The MDA manufacture date. Not user modifiable.                                                          |
| Manufacturing string         | Factory-inputted manufacturing text string. Not user modifiable.                                        |
| Administrative state         | Up – The MDA is administratively up.                                                                    |
|                              | Down – The MDA is administratively down.                                                                |
| Operational state            | Up – The MDA is operationally up.                                                                       |
|                              | Down – The MDA is operationally down.                                                                   |

| Label               | Description (Continued)                                                                                                                             |
|---------------------|-----------------------------------------------------------------------------------------------------------------------------------------------------|
| Time of last boot   | The date and time the most recent boot occurred.                                                                                                    |
| Current alarm state | Displays the alarm conditions for the specific MDA.                                                                                                 |
| Base MAC address    | The base chassis Ethernet MAC address. Special purpose MAC addresses used by the system software are constructed as offsets from this base address. |

**Sample Output**

```

*A:Dut-A# show mda 5/1 detail
=====
MDA 5/1 detail
=====
Slot Mda Provisioned Equipped Admin Operational
 Mda-type Mda-type State State

5 1 m20-1gb-xp-sfp m20-1gb-xp-sfp up up

MDA Specific Data
Maximum port count : 20
Number of ports equipped : 20
Network ingress queue policy : default
Capabilities : Ethernet
Fail On Error : disabled
Egress XPL error threshold : 1000
Egress XPL error window : 60

Hardware Data
Platform type : 7750
Part number : 3HE03612AAAB01
CLEI code : IPPAABFBAA
Serial number : NS093464752
Manufacture date : 08232009
Manufacturing string :
Manufacturing deviations :
Manufacturing assembly number :
Administrative state : up
Operational state : up
Temperature : 37C
Temperature threshold : 75C
Software version : N/A
Time of last boot : 2011/11/15 11:32:49
Current alarm state : alarm cleared
Base MAC address : 00:23:3e:ea:38:4b

QOS Settings

Ing. Named Pool Policy : None
Egr. Named Pool Policy : None
=====

```

```
A:Dut-A# show mda 1/1 detail
```

```
=====
MDA 1/1 detail
=====
```

| Slot | Mda | Provisioned Type<br>Equipped Type (if different) | Admin<br>State | Operational<br>State |
|------|-----|--------------------------------------------------|----------------|----------------------|
| 1    | 1   | cx20-10g-sfp                                     | up             | up                   |

```
MDA Specific Data
```

```
Maximum port count : 20
Number of ports equipped : 20
Network ingress queue policy : default
Capabilities : Ethernet
Min channel size : Sonet STS-192
Max channel size : Sonet STS-192
Max number of channels : 20
Channels in use : 0
```

```
Hardware Data
```

```
Platform type : 7950
Part number :
CLEI code :
Serial number : GRA03-126
Manufacture date :
Manufacturing string : (Not Specified)
Manufacturing deviations : (Not Specified)
Manufacturing assembly number : 82-0299-03
Administrative state : up
Operational state : up
Temperature : 45C
Temperature threshold : 75C
Software version : N/A
Time of last boot : 2012/05/23 20:30:55
Current alarm state : alarm cleared
Base MAC address : 8c:90:d3:be:69:8a
Firmware version : I-10.0.S209
```

```

QOS Settings

=====
```

```
A:Dut-A#
```

pools

**Syntax** **pools** *mda-id* [/port] [**access-app** [*pool-name* | **service** *service-id*]] | **queue-group** *queue-group-name*]]  
**pools** *mda-id* [/port] [*network-app* [*pool-name* | **queue-group** *queue-group-name*]]  
**pools** *mda-id* [/port] [*direction* [*pool-name* | **service** *service-id*] **queue-group** *queue-group-name*]]

**Context** show

**Description** This command displays pool information.

**Parameters** *mda-id*[/port] — Displays the pool information of the specified MDA and port.  
**access-app** *pool-name* — Displays the pool information of the specified QoS policy.  
**Values** access-ingress, access-egress  
**service** *service-id* — Displays pool information for the specified service.  
**Values** 1 — 2147483647  
**queue-group** *queue-group-name* — Display information for the specified queue group.  
**direction** — Specifies to display information for the ingress or egress direction.  
**Values** ingress, egress

**Output** **Show Pool Output** — The following table describes show pool output fields.

| Label            | Description                                                                                                                                                                                                   |
|------------------|---------------------------------------------------------------------------------------------------------------------------------------------------------------------------------------------------------------|
| Type             | Specifies the pool type.                                                                                                                                                                                      |
| ID               | Specifies the card/mda or card/MDA/port designation.                                                                                                                                                          |
| Application/Type | Specifies the nature of usage the pool would be used for. The pools could be used for access or network traffic at either ingress or egress.                                                                  |
| Pool Name        | Specifies the name of the pool being used.                                                                                                                                                                    |
| Resv CBS         | Specifies the percentage of pool size reserved for CBS.                                                                                                                                                       |
| Utilization      | Specifies the type of the slope policy.                                                                                                                                                                       |
| State            | The administrative status of the port.                                                                                                                                                                        |
| Start-Avg        | Specifies the percentage of the buffer utilized after which the drop probability starts to rise above 0.                                                                                                      |
| Max-Avg          | Specifies the percentage of the buffer utilized after which the drop probability is 100 percent. This implies that all packets beyond this point will be dropped.                                             |
| Time Avg Factor  | Specifies the time average factor the weighting between the previous shared buffer average utilization result and the new shared buffer utilization in determining the new shared buffer average utilization. |

| Label              | Description (Continued)                                                                                                                                       |
|--------------------|---------------------------------------------------------------------------------------------------------------------------------------------------------------|
| Actual ResvCBS     | Specifies the actual percentage of pool size reserved for CBS.                                                                                                |
| Admin ResvCBS      | Specifies the percentage of pool size reserved for CBS.                                                                                                       |
| PoolSize           | Specifies the size in percentage of buffer space. The value '-1' implies that the pool size should be computed as per fair weighting between all other pools. |
| Pool Total         | Displays the total pool size.                                                                                                                                 |
| Pool Shared        | Displays the amount of the pool which is shared.                                                                                                              |
| Pool Resv          | Specifies the percentage of reserved pool size.                                                                                                               |
| Pool Total In Use  | Displays the total amount of the pool which is in use.                                                                                                        |
| Pool Shared In Use | Displays the amount of the pool which is shared that is in use.                                                                                               |

```
*A:ALA-48# show pools 1/1
```

```
=====
```

| Type | Id    | App.    | Pool Name    | Actual ResvCBS<br>Admin ResvCBS | PoolSize |
|------|-------|---------|--------------|---------------------------------|----------|
| MDA  | 1/1   | Acc-Ing | default      | Sum                             |          |
| MDA  | 1/1   | Acc-Ing | MC Path Mgnt | 50                              |          |
| MDA  | 1/1   | Acc-Egr | default      | Sum                             |          |
| MDA  | 1/1   | Net-Ing | default      | Sum                             |          |
| MDA  | 1/1   | Net-Egr | default      | 50                              |          |
| Port | 1/1/1 | Acc-Ing | default      | Sum                             |          |
| Port | 1/1/1 | Acc-Egr | default      | Sum                             |          |
| Port | 1/1/1 | Net-Egr | default      | Sum                             |          |
| Port | 1/1/2 | Acc-Ing | default      | Sum                             |          |
| Port | 1/1/2 | Acc-Egr | default      | Sum                             |          |
| Port | 1/1/2 | Net-Egr | default      | Sum                             |          |
| Port | 1/1/3 | Acc-Ing | default      | Sum                             |          |
| Port | 1/1/3 | Acc-Egr | default      | Sum                             |          |
| Port | 1/1/3 | Net-Egr | default      | Sum                             |          |

## Hardware Commands

```

Port 1/1/4 Acc-Ing default
 Sum
Port 1/1/4 Acc-Egr default
 Sum
...
Port 1/1/12 Acc-Egr default
 Sum
Port 1/1/12 Net-Egr default
 Sum
=====
*A:ALA-48#

*A:ALA-48# show pools 1/1/1 network-egress
=====
Pool Information
=====
Port : 1/1/1
Application : Net-Egr Pool Name : default
Resv CBS : Sum

Utilization State Start-Avg Max-Avg Max-Prob

High-Slope Down 70% 90% 80%
Low-Slope Down 50% 75% 80%

Time Avg Factor : 7
Pool Total : 3072 KB
Pool Shared : 1536 KB Pool Resv : 1536 KB

Pool Total In Use : 0 KB
Pool Shared In Use : 0 KB Pool Resv In Use : 0 KB
WA Shared In Use : 0 KB

Hi-Slope Drop Prob : 0 Lo-Slope Drop Prob : 0

FC-Maps ID MBS Depth A.CIR A.PIR
 CBS O.CIR O.PIR

be 1/1/1 1536 0 0 100000
 28 0 Max
l2 1/1/1 1536 0 25000 100000
 96 25000 Max
af 1/1/1 1536 0 25000 100000
 320 25000 Max
l1 1/1/1 768 0 25000 100000
 96 25000 Max
h2 1/1/1 1536 0 100000 100000
 320 Max Max
ef 1/1/1 1536 0 100000 100000
 320 Max Max
h1 1/1/1 768 0 10000 100000
 96 10000 Max
nc 1/1/1 768 0 10000 100000
 96 10000 Max
=====
*A:ALA-48#

```

## Interface Configuration

```

*A:Dut-T# show pools 4/1/1 access-ingress
=====
Pool Information
=====
Port : 4/1/1
Application : Acc-Ing Pool Name : default
CLI Config. Resv CBS : 10%
Resv CBS Step : 1% Resv CBS Max : 30%
Amber Alarm Threshold: 10% Red Alarm Threshold: 0%

Queue-Groups

Utilization State Start-Avg Max-Avg Max-Prob

High-Slope Down 70% 90% 80%
Low-Slope Down 50% 75% 80%

Time Avg Factor : 7
Pool Total : 66048 KB
Pool Shared : 46080 KB Pool Resv : 19968 KB

Current Resv CBS Provisioned Rising Falling Alarm
%age all Queues Alarm Thd Alarm Thd Color

30% 40320 KB NA 1797 KB Amber
Pool Total In Use : 0 KB
Pool Shared In Use : 0 KB Pool Resv In Use : 0 KB
WA Shared In Use : 0 KB

Hi-Slope Drop Prob : 0 Lo-Slope Drop Prob : 0

Name Tap FC-Maps MBS HP-Only A.PIR A.CIR
 Tap FC-Maps CBS Depth O.PIR O.CIR

2->4/1/1:1->11
 MCast be 12 af 11 30720 KB 3072 KB 25000000 0
 h2 ef h1 nc 0 KB 0 Max 0
2->4/1/1:1->4
 3/1 af 81408 KB 9216 KB 25000000 0
 3360 KB 0 Max 0
2->4/1/1:1->4
 3/1 af 81408 KB 9216 KB 25000000 0
 3360 KB 0 Max 0
2->4/1/1:1->4
 4/* af 81408 KB 9216 KB 25000000 0
 3360 KB 0 Max 0
2->4/1/1:1->3
 3/1 12 81408 KB 9216 KB 25000000 0
 3360 KB 0 Max 0
2->4/1/1:1->3
 3/1 12 81408 KB 9216 KB 25000000 0
 3360 KB 0 Max 0
2->4/1/1:1->3
 4/* 12 81408 KB 9216 KB 25000000 0

```

## Hardware Commands

```

3360 KB 0 Max 0
2->4/1/1:1->2
 3/1 11 81408 KB 9216 KB 25000000 0
 3360 KB 0 Max 0
2->4/1/1:1->2
 3/1 11 81408 KB 9216 KB 25000000 0
 3360 KB 0 Max 0
2->4/1/1:1->2
 4/* 11 81408 KB 9216 KB 25000000 0
...
=====
*A:Dut-T#

*A:ALU-2011# show pools 2/1/1 access-egress
=====
Pool Information
=====
Port : 2/1/1
Application : Acc-Egr Pool Name : default
Resv CBS : Sum

Queue-Groups

policer-output-queues

Utilization State Start-Avg Max-Avg Max-Prob

High-Slope Down 70% 90% 80%
Low-Slope Down 50% 75% 80%

Time Avg Factor : 7
Pool Total : 6336 KB
Pool Shared : 4416 KB Pool Resv : 1920 KB

Pool Resv CBS Provisioned Rising Falling Alarm
 %age All Queues Alarm Thd Alarm Thd Color

40% 300KB 350KB 250KB Amber

Pool Total In Use : 0 KB
Pool Shared In Use : 0 KB Pool Resv In Use : 0 KB
WA Shared In Use : 0 KB

Hi-Slope Drop Prob : 0 Lo-Slope Drop Prob : 0

Name Tap FC-Maps MBS HP-Only A.PIR A.CIR
 Tap FC-Maps CBS Depth O.PIR O.CIR

2->2/1/1:100->1
 be 12 af 11 123 KB 15 KB 100000 0
 h2 ef h1 nc 0 KB 0 Max 0
accQGrp->policer-output-queues(2/1/1)->1
 n/a 123 KB 15 KB 100000 0
 0 KB 0 Max 0
accQGrp->policer-output-queues(2/1/1)->2
 n/a 123 KB 15 KB 100000 0

```

0 KB 0 Max 0

\*A:ALU-2011# show pools 2/1/1 access-egress

=====  
Pool Information  
=====

Port : 2/1/1  
Application : Acc-Egr Pool Name : default  
Resv CBS : Sum

-----  
Queue-Groups  
-----

-----  
policer-output-queues  
-----

| Utilization | State | Start-Avg | Max-Avg | Max-Prob |
|-------------|-------|-----------|---------|----------|
| High-Slope  | Down  | 70%       | 90%     | 80%      |
| Low-Slope   | Down  | 50%       | 75%     | 80%      |

Time Avg Factor : 7  
Pool Total : 6336 KB  
Pool Shared : 4416 KB Pool Resv : 1920 KB

| Pool Resv CBS %age | Provisioned All Queues | Rising Alarm Thd | Falling Alarm Thd | Alarm Color |
|--------------------|------------------------|------------------|-------------------|-------------|
|--------------------|------------------------|------------------|-------------------|-------------|

-----  
**CBS Oversubscription Alarm Info Pending**  
-----

Pool Total In Use : 0 KB  
Pool Shared In Use : 0 KB Pool Resv In Use : 0 KB  
WA Shared In Use : 0 KB

Hi-Slope Drop Prob : 0 Lo-Slope Drop Prob : 0

| Name | Tap | FC-Maps | MBS CBS | HP-Only Depth | A.PIR O.PIR | A.CIR O.CIR |
|------|-----|---------|---------|---------------|-------------|-------------|
|------|-----|---------|---------|---------------|-------------|-------------|

-----  
2->2/1/1:100->1  
be 12 af 11 123 KB 15 KB 100000 0  
h2 ef h1 nc 0 KB 0 Max 0  
accQGrp->policer-output-queues(2/1/1)->1  
n/a 123 KB 15 KB 100000 0  
0 KB 0 Max 0  
accQGrp->policer-output-queues(2/1/1)->2

\*A:ALU-2011#show pools 1/1/1 egress

=====  
Pool Information  
=====

Port : 1/1/1  
Application : Egress Pool Name : PoolData  
Resv CBS : 25% Policy Name : Port1-1-1

-----  
Queue-Groups  
-----

# Hardware Commands

```

Utilization State Start-Avg Max-Avg Max-Prob

High-Slope Down 70% 90% 80%
Low-Slope Down 50% 75% 80%
Time Avg Factor : 7
Pool Total : 64 KB
Pool Shared : 48 KB Pool Resv : 16 KB

Pool Resv CBS Provisioned Rising Falling Alarm
 %age All Queues Alarm Thd Alarm Thd Color

 40% 300KB 350KB 250KB Amber
Pool Total In Use : 0 KB
Pool Shared In Use : 0 KB Pool Resv In Use : 0 KB
WA Shared In Use : 0 KB
Hi-Slope Drop Prob : 0 Lo-Slope Drop Prob : 0

Name Tap FC-Maps MBS HP-Only A.PIR A.CIR
 CBS Depth O.PIR O.CIR

1->1/1/1:10->2
 af 128 KB 16 KB 100000 0
 0 KB 0 Max 0
1->1/1/1:10->4
 ll 128 KB 16 KB 100000 0
 0 KB 0 Max 0

Port : 1/1/1
Application : Egress Pool Name : PoolVideo
Resv CBS : 25% Policy Name : Port1-1-1

Queue-Groups

Utilization State Start-Avg Max-Avg Max-Prob

High-Slope Down 70% 90% 80%
Low-Slope Down 50% 75% 80%
Time Avg Factor : 7
Pool Total : 64 KB
Pool Shared : 48 KB Pool Resv : 16 KB

Pool Resv CBS Provisioned Rising Falling Alarm
 %age All Queues Alarm Thd Alarm Thd Color

 40% 300KB 350KB 250KB Amber
Pool Total In Use : 0 KB
Pool Shared In Use : 0 KB Pool Resv In Use : 0 KB
WA Shared In Use : 0 KB
Hi-Slope Drop Prob : 0 Lo-Slope Drop Prob : 0

Name Tap FC-Maps MBS HP-Only A.PIR A.CIR
 CBS Depth O.PIR O.CIR

1->1/1/1:10->5
 ef 128 KB 16 KB 100000 0
 0 KB 0 Max 0

```

## Interface Configuration

```

Port : 1/1/1
Application : Egress Pool Name : PoolVoice
Resv CBS : 50% Policy Name : Port1-1-1

Queue-Groups

Utilization State Start-Avg Max-Avg Max-Prob

High-Slope Down 70% 90% 80%
Low-Slope Down 50% 75% 80%
Time Avg Factor : 7
Pool Total : 64 KB
Pool Shared : 32 KB Pool Resv : 32 KB

Pool Resv CBS Provisioned Rising Falling Alarm
 %age All Queues Alarm Thd Alarm Thd Color

40% 300KB 350KB 250KB Amber
Pool Total In Use : 0 KB
Pool Shared In Use : 0 KB Pool Resv In Use : 0 KB
WA Shared In Use : 0 KB
Hi-Slope Drop Prob : 0 Lo-Slope Drop Prob : 0

Name Tap FC-Maps MBS HP-Only A.PIR A.CIR
 CBS Depth O.PIR O.CIR

1->1/1/1:10->3
 nc 128 KB 16 KB 100000 0
 0 KB 0 Max 0
=====
*A:ALU-2011#

```

### When alarm information is pending:

```

*A:Dut-T# show pools 4/1/1 access-ingress
=====
Pool Information
=====
Port : 4/1/1
Application : Acc-Ing Pool Name : default
CLI Config. Resv CBS : 10%
Resv CBS Step : 1% Resv CBS Max : 35%
Amber Alarm Threshold: 10% Red Alarm Threshold: 0%

Queue-Groups

Utilization State Start-Avg Max-Avg Max-Prob

High-Slope Down 70% 90% 80%
Low-Slope Down 50% 75% 80%

Time Avg Factor : 7
Pool Total : 66048 KB
Pool Shared : 46080 KB Pool Resv : 19968 KB

Current Resv CBS Provisioned Rising Falling Alarm

```

# Hardware Commands

```

%age all Queues Alarm Thd Alarm Thd Color

CBS Oversubscription Alarm Info Pending
Pool Total In Use : 0 KB
Pool Shared In Use : 0 KB Pool Resv In Use : 0 KB
WA Shared In Use : 0 KB

Hi-Slope Drop Prob : 0 Lo-Slope Drop Prob : 0

Name Tap FC-Maps MBS HP-Only A.PIR A.CIR
 Tap FC-Maps CBS Depth O.PIR O.CIR

2->4/1/1:1->11
 MCast be l2 af l1 30720 KB 3072 KB 25000000 0
 h2 ef h1 nc 0 KB 0 Max 0
2->4/1/1:1->4
 3/1 af 81408 KB 9216 KB 25000000 0
 3360 KB 0 Max 0
2->4/1/1:1->4
 3/1 af 81408 KB 9216 KB 25000000 0
 3360 KB 0 Max 0
2->4/1/1:1->4
 4/* af 81408 KB 9216 KB 25000000 0
 3360 KB 0 Max 0
2->4/1/1:1->3
 3/1 l2 81408 KB 9216 KB 25000000 0
 3360 KB 0 Max 0
2->4/1/1:1->3
 3/1 l2 81408 KB 9216 KB 25000000 0
 3360 KB 0 Max 0
2->4/1/1:1->3
 4/* l2 81408 KB 9216 KB 25000000 0
 3360 KB 0 Max 0
2->4/1/1:1->2
 3/1 l1 81408 KB 9216 KB 25000000 0
 3360 KB 0 Max 0
2->4/1/1:1->2
 3/1 l1 81408 KB 9216 KB 25000000 0
 3360 KB 0 Max 0
2->4/1/1:1->2
 4/* l1 81408 KB 9216 KB 25000000 0
 3360 KB 0 Max 0
2->4/1/1:1->1
 3/1 be h2 ef h1 81408 KB 9216 KB 25000000 0
 nc 3360 KB 0 Max 0
2->4/1/1:1->1
 3/1 be h2 ef h1 81408 KB 9216 KB 25000000 0
 nc 3360 KB 0 Max 0
2->4/1/1:1->1
 4/* be h2 ef h1 81408 KB 9216 KB 25000000 0
 nc 3360 KB 0 Max 0
=====
*A:Dut-T#

```

When alarm information is pending:

```
*A:Dut-T# show pools 9/2/1 egress
=====
Pool Information
=====
Port : 9/2/1
Application : Egress Pool Name : pool1
CLI Config. Resv CBS : 10% Policy Name : namedEgr
Resv CBS Step : 1% Resv CBS Max : 35%
Amber Alarm Threshold: 30% Red Alarm Threshold: 45%

Queue-Groups

Utilization State Start-Avg Max-Avg Max-Prob

High-Slope Down 70% 90% 80%
Low-Slope Down 50% 75% 80%

Time Avg Factor : 7
Pool Total : 258 KB
Pool Shared : 192 KB Pool Resv : 66 KB

Current Resv CBS Provisioned Rising Falling Alarm
%age all Queues Alarm Thd Alarm Thd Color

CBS Oversubscription Alarm Info Pending
Pool Total In Use : 0 KB
Pool Shared In Use : 0 KB Pool Resv In Use : 0 KB
WA Shared In Use : 0 KB

Hi-Slope Drop Prob : 0 Lo-Slope Drop Prob : 0

Name Tap FC-Maps MBS HP-Only A.PIR A.CIR
 Tap FC-Maps CBS Depth O.PIR O.CIR

1 Net=be Port=9/2/1
 be 66048 B 7680 B 1000000 0
 39 KB 0 Max 0

*A:Dut-T#
```

In Use Stat Note:

The pool shared in use stat only increases when a queue is asking for a buffer outside it's reserved size. If all the buffers in a pool are assigned to queues within their reserved size, then only the reserved in use size will increase. In case of resv CBS oversubscription (CBS sum for all queues is bigger then pool resvCbs), it is possible that pool resv in use stat can increase above the actual pool reserved size. For example:

```
Pool Total : 57344 KB
Pool Shared : 32768 KB Pool Resv : 24576 KB

Pool Total In Use : 57344 KB
Pool Shared In Use : 0 KB Pool Resv In Use: 57344 KB
```

---

## Show PEQ Commands

peq

**Syntax**    **peq** [*peq-slot*] [*detail*]

**Context**    show

**Description**    This command displays APEQ information.

**Output**    **PEQ Output Fields** — The following table describes **peq** output fields:

| Label                                               | Description                                            |
|-----------------------------------------------------|--------------------------------------------------------|
| Slot                                                | The number of the slot in which the APEQ is installed. |
| Provisioned Type<br>Equipped Type (if<br>different) | The APEQ type provisioned.                             |
| Admin State                                         | The administrative state.                              |
| Operational State                                   | The operational state.                                 |
| Input                                               | Specifies the input battery feed: A, or B              |
| Zone                                                | Specifies the chassis power zone.                      |
| Hardware Data:                                      |                                                        |
| Part number                                         | The APEQ part number.                                  |
| CLEI code                                           | The APEQ CLEI code.                                    |
| Serial number                                       | The APEQ serial number.                                |
| Manufacture date                                    | The date the APEQ was manufactured                     |
| Manufacturing deviations                            | Specifies any manufacturing deviations.                |
| Manufacturing assembly number                       | The APEQ assembly number.                              |
| Administrative state                                | Specifies the administrative state of the APEQ.        |
| Operational state                                   | Specifies the operational state of the APEQ.           |
| Time of last boot                                   | Indicates the time stamp of the last system restart.   |
| Current alarm state                                 | Indicates the current alarm state.                     |

## Sample Output

```
*A:Dut-A# show peq
```

```
=====
PEQ Summary
=====
```

| Slot | Provisioned Type<br>Equipped Type (if different) | Admin State | Operational State | Input<br>A B | Zone |
|------|--------------------------------------------------|-------------|-------------------|--------------|------|
| 1    | apeq-dc-2000                                     | down        | down              | Y N          | 1    |
| 2    | (not provisioned)<br>apeq-dc-2000                | up          | unprovisioned     | Y N          | 1    |
| 3    | apeq-dc-2000                                     | up          | up                | Y N          | 1    |
| 4    | apeq-dc-2000                                     | up          | up                | Y N          | 1    |
| 5    | apeq-dc-2000                                     | up          | up                | Y N          | 1    |
| 6    | apeq-dc-2000                                     | up          | up                | Y N          | 1    |
| 7    | apeq-dc-2000                                     | up          | up                | Y N          | 1    |
| 8    | apeq-dc-2000                                     | up          | up                | Y N          | 1    |
| 9    | apeq-dc-2000                                     | up          | up                | Y N          | 1    |
| 10   | apeq-dc-2000                                     | up          | up                | Y N          | 1    |
| 11   | apeq-dc-2000                                     | up          | up                | Y N          | 1    |
| 12   | apeq-dc-2000                                     | up          | up                | Y N          | 1    |

```
*A:Dut-A# show peq 1
```

```
=====
PEQ 1
=====
```

| Slot | Provisioned Type<br>Equipped Type (if different) | Admin State | Operational State | Input<br>A B | Zone |
|------|--------------------------------------------------|-------------|-------------------|--------------|------|
| 1    | apeq-dc-2000                                     | down        | down              | Y N          | 1    |

```
*A:Dut-A# show peq 1 detail
```

```
=====
PEQ 1
=====
```

| Slot | Provisioned Type<br>Equipped Type (if different) | Admin State | Operational State | Input<br>A B | Zone |
|------|--------------------------------------------------|-------------|-------------------|--------------|------|
| 1    | apeq-dc-2000                                     | down        | down              | Y N          | 1    |

```
Hardware Data
```

```
Part number : 3HE07114AARA01
CLEI code : IPUPAJHUAA
Serial number : NS1250G0116
Manufacture date : 12202012
Manufacturing deviations : (Not Specified)
Manufacturing assembly number: 8205320107
Time of last boot : 2014/01/07 11:01:44
Current alarm state : alarm active
=====
```

## Show PEQ Commands

\*A:Dut-A# show peg detail

```
=====
PEQ 1
=====
```

| Slot | Provisioned Type<br>Equipped Type (if different) | Admin State | Operational State | Input<br>A B | Zone |
|------|--------------------------------------------------|-------------|-------------------|--------------|------|
| 1    | apeq-dc-2000                                     | down        | down              | Y N          | 1    |

### Hardware Data

```
Part number : 3HE07114AARA01
CLEI code : IPUPAJHUAA
Serial number : NS1250G0116
Manufacture date : 12202012
Manufacturing deviations : (Not Specified)
Manufacturing assembly number: 8205320107
Time of last boot : 2014/01/07 11:01:44
Current alarm state : alarm active
```

```
=====
PEQ 2
=====
```

| Slot | Provisioned Type<br>Equipped Type (if different) | Admin State | Operational State | Input<br>A B | Zone |
|------|--------------------------------------------------|-------------|-------------------|--------------|------|
| 2    | (not provisioned)<br>apeq-dc-2000                | up          | unprovisioned     | Y N          | 1    |

### Hardware Data

```
Part number : 3HE07114AARA01
CLEI code : IPUPAJHUAA
Serial number : NS1249G0022
Manufacture date : 12202012
Manufacturing deviations : (Not Specified)
Manufacturing assembly number: 8205320107
Time of last boot : 2014/01/07 11:01:44
Current alarm state : alarm active
```

```
=====
PEQ 3
=====
```

| Slot | Provisioned Type<br>Equipped Type (if different) | Admin State | Operational State | Input<br>A B | Zone |
|------|--------------------------------------------------|-------------|-------------------|--------------|------|
| 3    | apeq-dc-2000                                     | up          | up                | Y N          | 1    |

### Hardware Data

```
Part number : 3HE07114AARA01
CLEI code : IPUPAJHUAA
Serial number : NS1250G0141
Manufacture date : 12202012
Manufacturing deviations : (Not Specified)
Manufacturing assembly number: 8205320107
Time of last boot : 2014/01/07 11:01:44
Current alarm state : alarm active
```

```

=====
PEQ 4
=====
Slot Provisioned Type Admin Operational Input Zone
 Equipped Type (if different) State State A B

4 apeq-dc-2000 up up Y N 1

Hardware Data
Part number : 3HE07114AARA01
CLEI code : IPUPAJHUAA
Serial number : NS1249G0201
Manufacture date : 12202012
Manufacturing deviations : (Not Specified)
Manufacturing assembly number: 8205320107
Time of last boot : 2014/01/07 11:01:44
Current alarm state : alarm active

```

```

=====
PEQ 5
=====
Slot Provisioned Type Admin Operational Input Zone
 Equipped Type (if different) State State A B

5 apeq-dc-2000 up up Y N 1

Hardware Data
Part number : 3HE07114AARA01
CLEI code : IPUPAJHUAA
Serial number : NS1250G0123
Manufacture date : 12202012
Manufacturing deviations : (Not Specified)
Manufacturing assembly number: 8205320107
Time of last boot : 2014/01/07 11:01:44
Current alarm state : alarm active

```

```

=====
PEQ 6
=====
Slot Provisioned Type Admin Operational Input Zone
 Equipped Type (if different) State State A B

6 apeq-dc-2000 up up Y N 1

Hardware Data
Part number : 3HE07114AARA01
CLEI code : IPUPAJHUAA
Serial number : NS1250G0061
Manufacture date : 12182012
Manufacturing deviations : (Not Specified)
Manufacturing assembly number: 8205320107
Time of last boot : 2014/01/07 11:01:44
Current alarm state : alarm active

```

## Show PEQ Commands

```

=====
PEQ 7
=====
Slot Provisioned Type Admin Operational Input Zone
 Equipped Type (if different) State State A B

7 apeq-dc-2000 up up Y N 1

Hardware Data
Part number : 3HE07114AARB01
CLEI code : IPUPAJHUAA
Serial number : NS13226A310
Manufacture date : 06042013
Manufacturing deviations : (Not Specified)
Manufacturing assembly number: 82-0532-02
Time of last boot : 2014/01/07 11:01:44
Current alarm state : alarm active

```

```

=====
PEQ 8
=====
Slot Provisioned Type Admin Operational Input Zone
 Equipped Type (if different) State State A B

8 apeq-dc-2000 up up Y N 1

Hardware Data
Part number : 3HE07114AARA01
CLEI code : IPUPAJHUAA
Serial number : NS1250G0152
Manufacture date : 12202012
Manufacturing deviations : (Not Specified)
Manufacturing assembly number: 8205320107
Time of last boot : 2014/01/07 11:01:44
Current alarm state : alarm active

```

```

=====
PEQ 9
=====
Slot Provisioned Type Admin Operational Input Zone
 Equipped Type (if different) State State A B

9 apeq-dc-2000 up up Y N 1

Hardware Data
Part number : 3HE07114AARA01
CLEI code : IPUPAJHUAA
Serial number : NS1250G0122
Manufacture date : 12202012
Manufacturing deviations : (Not Specified)
Manufacturing assembly number: 8205320107
Time of last boot : 2014/01/07 11:01:44
Current alarm state : alarm active

```

```

=====
PEQ 10
=====
Slot Provisioned Type Admin Operational Input Zone
 Equipped Type (if different) State State A B

10 apeq-dc-2000 up up Y N 1

Hardware Data
Part number : 3HE07114AARA01
CLEI code : IPUPAJHUAA
Serial number : NS1250G0146
Manufacture date : 12202012
Manufacturing deviations : (Not Specified)
Manufacturing assembly number: 8205320107
Time of last boot : 2014/01/07 11:01:44
Current alarm state : alarm active

=====
PEQ 11
=====
Slot Provisioned Type Admin Operational Input Zone
 Equipped Type (if different) State State A B

11 apeq-dc-2000 up up Y N 1

Hardware Data
Part number : 3HE07114AARA01
CLEI code : IPUPAJHUAA
Serial number : NS1249G0202
Manufacture date : 12202012
Manufacturing deviations : (Not Specified)
Manufacturing assembly number: 8205320107
Time of last boot : 2014/01/07 11:01:44
Current alarm state : alarm active

=====
PEQ 12
=====
Slot Provisioned Type Admin Operational Input Zone
 Equipped Type (if different) State State A B

12 apeq-dc-2000 up up Y N 1

Hardware Data
Part number : 3HE07114AARA01
CLEI code : IPUPAJHUAA
Serial number : NS1250G0115
Manufacture date : 12202012
Manufacturing deviations : (Not Specified)
Manufacturing assembly number: 8205320107
Time of last boot : 2014/01/07 11:01:44
Current alarm state : alarm active
=====

```

## megapools

**Syntax** **megapools** *slot-number*  
**megapools** *slot-number* **fp** *forwarding-plane* [**service-id** *service-id*] [**queue-group** *queue-group-name*] [**ingress** | **egress**]

**Context** show

**Description** This command displays megapool information. A megapool is a mechanism the IOM-3 flexpath traffic manager uses to allow oversubscription of buffer pools. Every buffer pool is created in the context of a megapool.

By default, all buffer pools are associated with a single megapool and the pools are not oversubscribed. When WRED queue support is enabled on the IOM, three megapools are used.

- The original megapool services the default and named pools.
- The second megapool services the system internal use pools.
- The third megapool is used by the buffer pools used by the WRED queues.

The traffic manager buffers are allocated to the three megapools without oversubscription. The WRED queue pools are allowed to oversubscribe their megapool, but the megapool protects the pools associated with the other megapools from buffer starvation that could be caused by that oversubscription.

**Parameters** *slot-number* — Displays information for the specified card slot.

*fp-number* — The *fp-number* parameter is optional following the **fp** command. If omitted, the system assumes forwarding plane number 1.

**queue-group** *queue-group-name* — Displays information for the specified port queue group name.

**ingress** — Displays ingress queue group information.

**egress** — Displays egress queue group information.

## sfm

**Syntax** **sfm** *sfm-id* [**detail**]

**Context** show

**Description** This command displays SFM status information.

**Parameters** *sfm-id* — Specifies the SFM identifier.

**detail** — Displays detailed MDA information.

### Sample Output

```
A:7950 XRS-20# show sfm
```

```
=====
SFM Summary
=====
```

| Slot | Provisioned Type<br>Equipped Type (if different) | Admin State | Operational State | Comments |
|------|--------------------------------------------------|-------------|-------------------|----------|
| 1    | sfm-x20                                          | up          | up                |          |
| 2    | sfm-x20                                          | up          | up                |          |
| 3    | sfm-x20                                          | up          | up                |          |
| 4    | sfm-x20                                          | up          | up                |          |
| 5    | sfm-x20                                          | up          | up                |          |
| 6    | (not provisioned)<br>sfm-x20                     | up          | unprovisioned     |          |
| 7    | (not provisioned)<br>sfm-x20                     | up          | unprovisioned     |          |
| 8    | (not provisioned)<br>sfm-x20                     | up          | unprovisioned     |          |

=====  
A:7950 XRS-20# show sfm 2 detail

=====  
Fabric 2

| Slot | Provisioned Type<br>Equipped Type (if different) | Admin State | Operational State | Comments |
|------|--------------------------------------------------|-------------|-------------------|----------|
| 2    | (not provisioned)<br>sfm-x20                     | up          | unprovisioned     |          |

=====  
Hardware Data

```

Part number : xx
CLEI code : xx
Serial number : xx
Manufacture date : xx
Manufacturing string : xx
Manufacturing deviations : xx
Manufacturing assembly number : xx
Administrative state : up
Operational state : unprovisioned
Time of last boot : N/A
Current alarm state : alarm cleared

```

=====



**Output Port Output** — The following tables describe port output fields:

- [General Port Output Fields on page 335](#)
- [Entering port ranges: on page 337](#)
- [Specific Port Output Fields on page 338](#)
- [Detailed Port Output Fields on page 344](#)
- [Ethernet Output on page 351](#)
- [Ethernet-Like Medium Statistics Output Fields on page 353](#)
- [Port Associations Output Fields on page 356](#)
- 

| Label       | Description                                                                                                                                                                                                                                                                                                                                                                                                 |
|-------------|-------------------------------------------------------------------------------------------------------------------------------------------------------------------------------------------------------------------------------------------------------------------------------------------------------------------------------------------------------------------------------------------------------------|
| Port ID     | The port ID configured or displayed in the <i>slot/mda/port</i> format.                                                                                                                                                                                                                                                                                                                                     |
| Admin State | Up — The administrative state is up.<br>Down — The administrative state is down.                                                                                                                                                                                                                                                                                                                            |
| Phy Link    | Yes — A physical link is present.<br>No — A physical link is not present.                                                                                                                                                                                                                                                                                                                                   |
| Port State  | Up — The port is physically present and has physical link present.<br>Down — The port is physically present but does not have a link. Note that this state may also be considered as Link Down.<br>Ghost — A port that is not physically present.<br>None — The port is in its initial creation state or about to be deleted.<br>Link Up — A port that is physically present and has physical link present. |
| Cfg MTU     | The configured MTU.                                                                                                                                                                                                                                                                                                                                                                                         |
| Oper MTU    | The negotiated size of the largest packet which can be sent on the port specified in octets.                                                                                                                                                                                                                                                                                                                |
| LAG ID      | The LAG or multi-link trunk (MLT) that the port is assigned to.                                                                                                                                                                                                                                                                                                                                             |
| Port Mode   | network — The port is configured for transport network use.<br>access — The port is configured for service access.<br>hybrid — The port is configured for both access and network use.                                                                                                                                                                                                                      |
| Port Encap  | Null — Ingress frames will not use tags or labels to delineate a service.                                                                                                                                                                                                                                                                                                                                   |

## Port Show Commands

| Label       | Description (Continued)                                                                                                                                                                                                                                                                                                   |
|-------------|---------------------------------------------------------------------------------------------------------------------------------------------------------------------------------------------------------------------------------------------------------------------------------------------------------------------------|
|             | dot1q – Ingress frames carry 802.1Q tags where each tag signifies a different service.                                                                                                                                                                                                                                    |
| Port Type   | The type of port or optics installed.                                                                                                                                                                                                                                                                                     |
| SFP/MDI MDX | GIGE – Indicates the GigE SFP type.<br>FASTE – Indicates the FastE SFP type.<br>GIGX – Indicates the GigX SFP type.<br>MDI – Indicates that the Ethernet interface is of type MDI (Media Dependent Interface).<br>MDX – Indicates that the Ethernet interface is of type MDX (Media Dependent Interface with crossovers). |

### Sample Output

```
*A:HW_Node_A# show port 1/1/1
```

```
=====
Ethernet Oam (802.3ah)
=====
Admin State : downOper State : disabled (protocol state)
Ignore-efm-state : Enabled/Disabled
=====
```

```
*A:7950 XRS-20# show port 1/1/1
```

```
=====
Ethernet Interface
=====
Description : 10-Gig Ethernet
Interface : 1/1/1
Link-level : Ethernet
Admin State : down
Oper State : down
Physical Link : No
Single Fiber Mode : No
IfIndex : 35684352
Last State Change : 05/23/2012 12:27:57
Last Cleared Time : N/A
Phys State Chng Cnt: 0

Oper Speed : 10 Gbps
Config Speed : N/A
Oper Duplex : full
Config Duplex : N/A
MTU : 1578
Min Frame Length : 64 Bytes
Hold time up : 0 seconds
Hold time down : 0 seconds
DDM Events : Enabled

Configured Mode : network
Dot1Q Ethertype : 0x8100
PBB Ethertype : 0x88e7
Ing. Pool % Rate : 100
Net. Egr. Queue Pol: default
Egr. Sched. Pol : n/a

Encap Type : null
QinQ Ethertype : 0x8100
Egr. Pool % Rate : 100
```

## Interface Configuration

```
Auto-negotiate : N/A
Accounting Policy : None
Egress Rate : Default
Load-balance-algo : Default

Down-when-looped : Disabled
Loop Detected : False
Use Broadcast Addr : False

Sync. Status Msg. : Disabled
Tx DUS/DNU : Disabled
SSM Code Type : sdh

Down On Int. Error : Disabled

CRC Mon SD Thresh : Disabled
CRC Mon SF Thresh : Disabled

MDI/MDX : N/A
Collect-stats : Disabled
Ingress Rate : Default
LACP Tunnel : Disabled

Keep-alive : 10
Retry : 120

Rx Quality Level : N/A
Tx Quality Level : N/A

Configured Address :
Hardware Address :
Cfg Alarm : remote local
=====
Traffic Statistics
=====
 Input Output

Octets 0 0
Packets 0 0
Errors 0 0
=====
Port Statistics
=====
 Input Output

Unicast Packets 0 0
Multicast Packets 0 0
Broadcast Packets 0 0
Discards 0 0
Unknown Proto Discards 0 0
=====
Ethernet-like Medium Statistics
=====
Alignment Errors : 0 Sngl Collisions : 0
FCS Errors : 0 Mult Collisions : 0
SQE Test Errors : 0 Late Collisions : 0
CSE : 0 Excess Collisns : 0
Too long Frames : 0 Int MAC Tx Errs : 0
Symbol Errors : 0 Int MAC Rx Errs : 0
In Pause Frames : 0 Out Pause Frames : 0
=====
Entering port ranges:
*A:ALU-1# configure port 1/1/[1..3] shut
*A:ALU-1# show port 1/1
=====
Ports on Slot 1
=====
```

## Port Show Commands

```

Port Admin Link Port Cfg Oper LAG/ Port Port Port SFP/XFP/
Id State State State MTU MTU Bndl Mode Encp Type MDIMDX

1/1/1 Down No Down 1518 1518 1 accs dotq gige
1/1/2 Down No Down 1578 1578 - netw null gige
1/1/3 Down No Down 1578 1578 - netw null gige
1/1/4 Up No Down 1514 1514 - accs null gige
1/1/5 Up No Down 1578 1578 - netw null gige
=====
*A:ALU-1#

```

**Specific Port Output** — The following table describes port output fields for a specific port.

| Label          | Description                                                                                                                                                                                                                |
|----------------|----------------------------------------------------------------------------------------------------------------------------------------------------------------------------------------------------------------------------|
| Description    | A text description of the port.                                                                                                                                                                                            |
| Interface      | The port ID displayed in the <i>slot/mda/port</i> format.                                                                                                                                                                  |
| Speed          | The speed of the interface.                                                                                                                                                                                                |
| Link-level     | Ethernet — The port is configured as Ethernet.                                                                                                                                                                             |
| MTU            | The size of the largest packet which can be sent/received on the Ethernet physical interface, specified in octets.                                                                                                         |
| Admin State    | Up — The port is administratively up.<br>Down — The port is administratively down.                                                                                                                                         |
| Oper State     | Up — The port is operationally up.<br>Down — The port is operationally down.<br><br>Additionally, the <i>lag-id</i> of the LAG it belongs to in addition to the status of the LAG member (active or standby) is specified. |
| Duplex         | Full — The link is set to full duplex mode.<br>Half — The link is set to half duplex mode.                                                                                                                                 |
| Hold time up   | The link up dampening time in seconds. The port link dampening timer value which reduces the number of link transitions reported to upper layer protocols.                                                                 |
| Hold time down | The link down dampening time in seconds. The <b>down</b> timer controls the dampening timer for link down transitions.                                                                                                     |
| Physical Link  | Yes — A physical link is present.<br>No — A physical link is not present.                                                                                                                                                  |
| IfIndex        | Displays the interface's index number which reflects its initialization sequence.                                                                                                                                          |
| Last State chg | Displays the system time moment that the peer is up.                                                                                                                                                                       |

| Label               | Description (Continued)                                                                                                                                                                                                                                                                                                                                                                                                                                                                                                                                                                               |
|---------------------|-------------------------------------------------------------------------------------------------------------------------------------------------------------------------------------------------------------------------------------------------------------------------------------------------------------------------------------------------------------------------------------------------------------------------------------------------------------------------------------------------------------------------------------------------------------------------------------------------------|
| Last State Change   | Displays the system time moment that the MC-LAG group is up.                                                                                                                                                                                                                                                                                                                                                                                                                                                                                                                                          |
| Phys State Chng Cnt | <p>Increments when a fully qualified (de-bounced) transition occurs at the physical layer of an ethernet port which includes the following transitions of the Port State as shown in the “show port” summary:</p> <ul style="list-style-type: none"> <li>- from “Down” to either “Link Up” or “Up”</li> <li>- from either “Link Up” or “Up” to “Down”</li> </ul> <p>This counter does not increment for changes purely in the link protocol states (e.g. "Link Up" to "Up"). The counter is reset if the container objects for the port are deleted (e.g. MDA deconfigured, or IOM type changes).</p> |
| Last Cleared Time   | Displays the system time moment that the peer is up.                                                                                                                                                                                                                                                                                                                                                                                                                                                                                                                                                  |
| DDM Events          | <p>Enabled – DDM events are enabled</p> <p>Disabled – DDM events are disabled</p>                                                                                                                                                                                                                                                                                                                                                                                                                                                                                                                     |
| Configured Mode     | <p>network – The port is configured for transport network use.</p> <p>access – The port is configured for service access.</p>                                                                                                                                                                                                                                                                                                                                                                                                                                                                         |
| Dot1Q Ethertype     | Indicates the Ethertype expected when the port's encapsulation type is Dot1Q.                                                                                                                                                                                                                                                                                                                                                                                                                                                                                                                         |
| QinQ Ethertype      | Indicates the Ethertype expected when the port's encapsulation type is QinQ.                                                                                                                                                                                                                                                                                                                                                                                                                                                                                                                          |
| Net. Egr. Queue Pol | Specifies the network egress queue policy or that the default policy is used.                                                                                                                                                                                                                                                                                                                                                                                                                                                                                                                         |
| Encap Type          | <p>Null – Ingress frames will not use any tags or labels to delineate a service.</p> <p>dot1q – Ingress frames carry 802.1Q tags where each tag signifies a different service.</p>                                                                                                                                                                                                                                                                                                                                                                                                                    |
| Active Alarms       | The number of alarms outstanding on this port.                                                                                                                                                                                                                                                                                                                                                                                                                                                                                                                                                        |
| Auto-negotiate      | <p>True – The link attempts to automatically negotiate the link speed and duplex parameters.</p> <p>False – The duplex and speed values are used for the link.</p>                                                                                                                                                                                                                                                                                                                                                                                                                                    |
| Alarm State         | The current alarm state of the port.                                                                                                                                                                                                                                                                                                                                                                                                                                                                                                                                                                  |
| Collect Stats       | Enabled – The collection of accounting and statistical data for the network Ethernet port is enabled. When applying accounting policies the data by default will be collected in the appropriate records and written to the designated billing file.                                                                                                                                                                                                                                                                                                                                                  |

## Port Show Commands

| Label              | Description (Continued)                                                                                                                                                |
|--------------------|------------------------------------------------------------------------------------------------------------------------------------------------------------------------|
|                    | Disabled — Collection is disabled. Statistics are still accumulated by the IOM cards, however, the CPU will not obtain the results and write them to the billing file. |
| Egress Rate        | The maximum amount of egress bandwidth (in kilobits per second) that this Ethernet interface can generate.                                                             |
| Egress Buf (Acc)   | The access-buffer policy for the egress buffer.                                                                                                                        |
| Egress Buf (Net)   | The network-buffer policy for the egress buffer.                                                                                                                       |
| Egress Pool Size   | The amount of egress buffer space, expressed as a percentage of the available buffer space that will be allocated to the port or channel for egress buffering.         |
| Ingress Buf (Acc)  | The access-buffer policy for the ingress buffer.                                                                                                                       |
| Ingress Pool Size  | The amount of ingress buffer space, expressed as a percentage of the available buffer space that will be allocated to the port or channel for ingress buffering.       |
| Configured Address | The base chassis Ethernet MAC address.                                                                                                                                 |
| Hardware Address   | The interface's hardware or system assigned MAC address at its protocol sub-layer.                                                                                     |
| Transceiver Type   | Type of the transceiver.                                                                                                                                               |
| Model Number       | The model number of the transceiver.                                                                                                                                   |
| Transceiver Code   | The code for the transmission media.                                                                                                                                   |
| Laser Wavelength   | The light wavelength transmitted by the transceiver's laser.                                                                                                           |
| Connector Code     | The vendor organizationally unique identifier field (OUI) contains the IEEE company identifier for the vendor.                                                         |
| Diag Capable       | Indicates if the transceiver is capable of doing diagnostics.                                                                                                          |
| Vendor OUI         | The vendor-specific identifier field (OUI) contains the IEEE company identifier for the vendor.                                                                        |
| Manufacture date   | The manufacturing date of the hardware component in the mmddyyyy ASCII format.                                                                                         |
| Media              | The media supported for the SFP.                                                                                                                                       |
| Serial Number      | The vendor serial number of the hardware component.                                                                                                                    |
| Part Number        | The vendor part number contains ASCII characters, defining the vendor part number or product name.                                                                     |

| Label           | Description (Continued)                                                                                                                                    |
|-----------------|------------------------------------------------------------------------------------------------------------------------------------------------------------|
| Input/Output    | When the collection of accounting and statistical data is enabled, then octet, packet, and error statistics are displayed.                                 |
| Description     | A text description of the port.                                                                                                                            |
| Interface       | The port ID displayed in the <i>slot/mda/port</i> format.                                                                                                  |
| Speed           | The speed of the interface                                                                                                                                 |
| Link-level      | Ethernet – The port is configured as Ethernet.                                                                                                             |
| MTU             | The size of the largest packet which can be sent/received on the Ethernet physical interface, specified in octets.                                         |
| Admin State     | Up – The port is administratively up.                                                                                                                      |
|                 | Down – The port is administratively down.                                                                                                                  |
| Oper State      | Up – The port is operationally up.                                                                                                                         |
|                 | Down – The port is operationally down.                                                                                                                     |
| Duplex          | Full – The link is set to full duplex mode.                                                                                                                |
|                 | Half – The link is set to half duplex mode.                                                                                                                |
| Hold time up    | The link up dampening time in seconds. The port link dampening timer value which reduces the number of link transitions reported to upper layer protocols. |
| Hold time down  | The link down dampening time in seconds. The <b>down</b> timer controls the dampening timer for link down transitions.                                     |
| IfIndex         | Displays the interface's index number which reflects its initialization sequence.                                                                          |
| Phy Link        | Yes – A physical link is present.                                                                                                                          |
|                 | No – A physical link is not present.                                                                                                                       |
| Configured Mode | network – The port is configured for transport network use.                                                                                                |
|                 | access – The port is configured for service access.                                                                                                        |
| Network Qos Pol | The network QoS policy ID applied to the port.                                                                                                             |
| Encap Type      | Null – Ingress frames will not use any tags or labels to delineate a service.                                                                              |
|                 | dot1q – Ingress frames carry 802.1Q tags where each tag signifies a different service.                                                                     |
| Active Alarms   | The number of alarms outstanding on this port.                                                                                                             |

## Port Show Commands

| Label                        | Description (Continued)                                                                                                                                                                                                                                                                                                                                                                                                                                                                                                                                                                                                 |
|------------------------------|-------------------------------------------------------------------------------------------------------------------------------------------------------------------------------------------------------------------------------------------------------------------------------------------------------------------------------------------------------------------------------------------------------------------------------------------------------------------------------------------------------------------------------------------------------------------------------------------------------------------------|
| Auto-negotiate               | <p>True — The link attempts to automatically negotiate the link speed and duplex parameters.</p> <p>False — The duplex and speed values are used for the link.</p>                                                                                                                                                                                                                                                                                                                                                                                                                                                      |
| Alarm State                  | The current alarm state of the port.                                                                                                                                                                                                                                                                                                                                                                                                                                                                                                                                                                                    |
| Collect Stats                | <p>Enabled — The collection of accounting and statistical data for the network Ethernet port is enabled. When applying accounting policies the data by default will be collected in the appropriate records and written to the designated billing file.</p> <p>Disabled — Collection is disabled. Statistics are still accumulated by the IOM cards, however, the CPU will not obtain the results and write them to the billing file.</p>                                                                                                                                                                               |
| Down-When-Looped             | Shows whether the feature is enabled or disabled.                                                                                                                                                                                                                                                                                                                                                                                                                                                                                                                                                                       |
| Egress Buf (Acc)             | The access-buffer policy for the egress buffer.                                                                                                                                                                                                                                                                                                                                                                                                                                                                                                                                                                         |
| Egress Buf (Net)             | The network-buffer policy for the egress buffer.                                                                                                                                                                                                                                                                                                                                                                                                                                                                                                                                                                        |
| Ingress Buf (Acc)            | The access-buffer policy for the ingress buffer.                                                                                                                                                                                                                                                                                                                                                                                                                                                                                                                                                                        |
| Ingress Pool Size            | The amount of ingress buffer space, expressed as a percentage of the available buffer space, that will be allocated to the port or channel for ingress buffering.                                                                                                                                                                                                                                                                                                                                                                                                                                                       |
| Configured Address           | The base chassis Ethernet MAC address.                                                                                                                                                                                                                                                                                                                                                                                                                                                                                                                                                                                  |
| Hardware Address             | The interface's hardware or system assigned MAC address at its protocol sub-layer.                                                                                                                                                                                                                                                                                                                                                                                                                                                                                                                                      |
| Errors Input/Output          | <p>For packet-oriented interfaces, the number of inbound packets that contained errors preventing them from being deliverable to a higher-layer protocol. For character-oriented or fixed-length interfaces, the number of inbound transmission units that contained errors preventing them from being deliverable to a higher-layer protocol.</p> <p>For packet-oriented interfaces, the number of outbound packets that could not be transmitted because of errors. For character-oriented or fixed-length interfaces, the number of outbound transmission units that could not be transmitted because of errors.</p> |
| Unicast Packets Input/Output | The number of packets, delivered by this sub-layer to a higher (sub-) layer, which were not addressed to a multicast or broadcast address at this sub-layer. The total number of packets that higher-level protocols requested be transmitted, and which were not addressed to a multicast or broadcast address at this sub-layer, including those that were discarded or not sent.                                                                                                                                                                                                                                     |

| Label                                  | Description (Continued)                                                                                                                                                                                                                                                                                                                                                                                                                                                                                                                                                                                     |
|----------------------------------------|-------------------------------------------------------------------------------------------------------------------------------------------------------------------------------------------------------------------------------------------------------------------------------------------------------------------------------------------------------------------------------------------------------------------------------------------------------------------------------------------------------------------------------------------------------------------------------------------------------------|
| Multicast Packets Input/Output         | The number of packets, delivered by this sub-layer to a higher (sub-) layer, which were addressed to a multicast address at this sub-layer. For a MAC layer protocol, this includes both group and functional addresses. The total number of packets that higher-level protocols requested be transmitted, and which were addressed to a multicast address at this sub-layer, including those that were discarded or not sent. For a MAC layer protocol, this includes both Group and Functional addresses.                                                                                                 |
| Broadcast Packets Input/Output         | The number of packets, delivered by this sub-layer to a higher (sub-) layer, which were addressed to a broadcast address at this sub-layer. The total number of packets that higher-level protocols requested be transmitted, and which were addressed to a multicast address at this sub-layer, including those that were discarded or not sent. For a MAC layer protocol, this includes both Group and Functional addresses.                                                                                                                                                                              |
| Discards Input/Output                  | The number of inbound packets chosen to be discarded to possibly free up buffer space.                                                                                                                                                                                                                                                                                                                                                                                                                                                                                                                      |
| Unknown Protocol Discards Input/Output | For packet-oriented interfaces, the number of packets received through the interface which were discarded because of an unknown or unsupported protocol. For character-oriented or fixed-length interfaces that support protocol multiplexing the number of transmission units received via the interface which were discarded because of an unknown or unsupported protocol. For any interface that does not support protocol multiplexing, this counter will always be 0. For ATM, this field displays cells discarded on an invalid vpi/vci. Unknown proto discards do not show up in the packet counts. |
| Errors                                 | This field displays the number of cells discarded due to uncorrectable HEC errors. Errors do not show up in the raw cell counts.                                                                                                                                                                                                                                                                                                                                                                                                                                                                            |
| Sync. Status Msg                       | Whether synchronization status messages are enabled or disabled.                                                                                                                                                                                                                                                                                                                                                                                                                                                                                                                                            |
| Tx DUS/DNU                             | Whether the QL value is forcibly set to QL-DUS/QL-DNU.                                                                                                                                                                                                                                                                                                                                                                                                                                                                                                                                                      |
| Rx Quality Level                       | Indicates which QL value has been received from the interface.                                                                                                                                                                                                                                                                                                                                                                                                                                                                                                                                              |
| Tx Quality Level                       | Indicates which QL value is being transmitted out of the interface.                                                                                                                                                                                                                                                                                                                                                                                                                                                                                                                                         |
| SSM Code Type                          | Indicates the SSM code type in use on the port.                                                                                                                                                                                                                                                                                                                                                                                                                                                                                                                                                             |

**Detailed Port Output** — The following table describes detailed port output fields.

| Label               | Description                                                                                                                                                                                                                                                                                                                                                                                                                                                                                                                           |
|---------------------|---------------------------------------------------------------------------------------------------------------------------------------------------------------------------------------------------------------------------------------------------------------------------------------------------------------------------------------------------------------------------------------------------------------------------------------------------------------------------------------------------------------------------------------|
| Description         | A text description of the port.                                                                                                                                                                                                                                                                                                                                                                                                                                                                                                       |
| Interface           | The port ID displayed in the <i>slot/mda/port</i> format.                                                                                                                                                                                                                                                                                                                                                                                                                                                                             |
| Speed               | The speed of the interface.                                                                                                                                                                                                                                                                                                                                                                                                                                                                                                           |
| Link-level          | Ethernet — The port is configured as Ethernet.                                                                                                                                                                                                                                                                                                                                                                                                                                                                                        |
| MTU                 | The size of the largest packet which can be sent/received on the Ethernet physical interface, specified in octets.                                                                                                                                                                                                                                                                                                                                                                                                                    |
| Admin State         | Up — The port is administratively up.<br>Down — The port is administratively down.                                                                                                                                                                                                                                                                                                                                                                                                                                                    |
| Oper State          | Up — The port is operationally up.<br>Down — The port is operationally down.                                                                                                                                                                                                                                                                                                                                                                                                                                                          |
| Duplex              | Full — The link is set to full duplex mode.<br>Half — The link is set to half duplex mode.                                                                                                                                                                                                                                                                                                                                                                                                                                            |
| Hold time up        | The link up dampening time in seconds. The port link dampening timer value which reduces the number of link transitions reported to upper layer protocols.                                                                                                                                                                                                                                                                                                                                                                            |
| Hold time down      | The link down dampening time in seconds. The <b>down</b> timer controls the dampening timer for link down transitions.                                                                                                                                                                                                                                                                                                                                                                                                                |
| IfIndex             | Displays the interface's index number which reflects its initialization sequence.                                                                                                                                                                                                                                                                                                                                                                                                                                                     |
| Phy Link            | Yes — A physical link is present.<br>No — A physical link is not present.                                                                                                                                                                                                                                                                                                                                                                                                                                                             |
| Phys State Chng Cnt | Increments when a fully qualified (de-bounced) transition occurs at the physical layer of an ethernet port which includes the following transitions of the Port State as shown in the “show port” summary:<br>- from “Down” to either “Link Up” or “Up”<br>- from either “Link Up” or “Up” to “Down”<br>This counter does not increment for changes purely in the link protocol states (e.g. "Link Up" to "Up"). The counter is reset if the container objects for the port are deleted (e.g. MDA deconfigured, or IOM type changes). |
| Last Cleared Time   | Displays the system time moment that the peer is up.                                                                                                                                                                                                                                                                                                                                                                                                                                                                                  |

| Label             | Description (Continued)                                                                                                                                                                                                                                                                                                                                                                                                        |
|-------------------|--------------------------------------------------------------------------------------------------------------------------------------------------------------------------------------------------------------------------------------------------------------------------------------------------------------------------------------------------------------------------------------------------------------------------------|
| DDM Events        | Enabled – DDM events are enabled<br>Disabled – DDM events are disabled                                                                                                                                                                                                                                                                                                                                                         |
| Configured Mode   | network – The port is configured for transport network use.<br>access – The port is configured for service access.                                                                                                                                                                                                                                                                                                             |
| Network Qos Pol   | The QoS policy ID applied to the port.                                                                                                                                                                                                                                                                                                                                                                                         |
| Access Egr. Qos   | Specifies the access egress policy or that the default policy 1 is in use.                                                                                                                                                                                                                                                                                                                                                     |
| Egr. Sched. Pol   | Specifies the port scheduler policy or that the default policy default is in use.                                                                                                                                                                                                                                                                                                                                              |
| Encap Type        | Null – Ingress frames will not use any tags or labels to delineate a service.<br>dot1q – Ingress frames carry 802.1Q tags where each tag signifies a different service.                                                                                                                                                                                                                                                        |
| Active Alarms     | The number of alarms outstanding on this port.                                                                                                                                                                                                                                                                                                                                                                                 |
| Auto-negotiate    | True – The link attempts to automatically negotiate the link speed and duplex parameters.<br>False – The duplex and speed values are used for the link.                                                                                                                                                                                                                                                                        |
| Alarm State       | The current alarm state of the port.                                                                                                                                                                                                                                                                                                                                                                                           |
| Collect Stats     | Enabled – The collection of accounting and statistical data for the network Ethernet port is enabled. When applying accounting policies the data by default will be collected in the appropriate records and written to the designated billing file.<br>Disabled – Collection is disabled. Statistics are still accumulated by the IOM cards, however, the CPU will not obtain the results and write them to the billing file. |
| Down-When-Looped  | Shows whether the feature is enabled or disabled.                                                                                                                                                                                                                                                                                                                                                                              |
| Egress Rate       | The maximum amount of egress bandwidth (in kilobits per second) that this Ethernet interface can generate.                                                                                                                                                                                                                                                                                                                     |
| Egress Buf (Acc)  | The access-buffer policy for the egress buffer.                                                                                                                                                                                                                                                                                                                                                                                |
| Egress Buf (Net)  | The network-buffer policy for the egress buffer.                                                                                                                                                                                                                                                                                                                                                                               |
| Egress Pool Size  | The amount of egress buffer space, expressed as a percentage of the available buffer space that will be allocated to the port or channel for egress buffering.                                                                                                                                                                                                                                                                 |
| Ingress Buf (Acc) | The access-buffer policy for the ingress buffer.                                                                                                                                                                                                                                                                                                                                                                               |

## Port Show Commands

| <b>Label</b>                   | <b>Description (Continued)</b>                                                                                                                                                                                                                                                                                                                                                                                                                                                                                                                                                                               |
|--------------------------------|--------------------------------------------------------------------------------------------------------------------------------------------------------------------------------------------------------------------------------------------------------------------------------------------------------------------------------------------------------------------------------------------------------------------------------------------------------------------------------------------------------------------------------------------------------------------------------------------------------------|
| Ingress Pool Size              | The amount of ingress buffer space, expressed as a percentage of the available buffer space, that will be allocated to the port or channel for ingress buffering.                                                                                                                                                                                                                                                                                                                                                                                                                                            |
| Configured Address             | The base chassis Ethernet MAC address.                                                                                                                                                                                                                                                                                                                                                                                                                                                                                                                                                                       |
| Hardware Address               | The interface's hardware or system assigned MAC address at its protocol sub-layer.                                                                                                                                                                                                                                                                                                                                                                                                                                                                                                                           |
| Errors Input/Output            | For packet-oriented interfaces, the number of inbound packets that contained errors preventing them from being deliverable to a higher-layer protocol. For character-oriented or fixed-length interfaces, the number of inbound transmission units that contained errors preventing them from being deliverable to a higher-layer protocol.<br>For packet-oriented interfaces, the number of outbound packets that could not be transmitted because of errors. For character-oriented or fixed-length interfaces, the number of outbound transmission units that could not be transmitted because of errors. |
| Unicast Packets Input/Output   | The number of packets, delivered by this sub-layer to a higher (sub-) layer, which were not addressed to a multicast or broadcast address at this sub-layer. The total number of packets that higher-level protocols requested be transmitted, and which were not addressed to a multicast or broadcast address at this sub-layer, including those that were discarded or not sent.                                                                                                                                                                                                                          |
| Multicast Packets Input/Output | The number of packets, delivered by this sub-layer to a higher (sub-) layer, which were addressed to a multicast address at this sub-layer. For a MAC layer protocol, this includes both Group and Functional addresses. The total number of packets that higher-level protocols requested be transmitted, and which were addressed to a multicast address at this sub-layer, including those that were discarded or not sent. For a MAC layer protocol, this includes both Group and Functional addresses.                                                                                                  |
| Broadcast Packets Input/Output | The number of packets, delivered by this sub-layer to a higher (sub-) layer, which were addressed to a broadcast address at this sub-layer. The total number of packets that higher-level protocols requested be transmitted, and which were addressed to a multicast address at this sub-layer, including those that were discarded or not sent. For a MAC layer protocol, this includes both Group and Functional addresses.                                                                                                                                                                               |
| Discards Input/Output          | The number of inbound packets chosen to be discarded to possibly free up buffer space.                                                                                                                                                                                                                                                                                                                                                                                                                                                                                                                       |

| Label                               | Description (Continued)                                                                                                                                                                                                                                                                                                                                                                                                                                                     |
|-------------------------------------|-----------------------------------------------------------------------------------------------------------------------------------------------------------------------------------------------------------------------------------------------------------------------------------------------------------------------------------------------------------------------------------------------------------------------------------------------------------------------------|
| Unknown Proto Discards Input/Output | For packet-oriented interfaces, the number of packets received through the interface which were discarded because of an unknown or unsupported protocol. For character-oriented or fixed-length interfaces that support protocol multiplexing the number of transmission units received via the interface which were discarded because of an unknown or unsupported protocol. For any interface that does not support protocol multiplexing, this counter will always be 0. |
| LLF Admin State                     | Displays the Link Loss Forwarding administrative state.                                                                                                                                                                                                                                                                                                                                                                                                                     |
| LLF Oper State                      | Displays the Link Loss Forwarding operational state.                                                                                                                                                                                                                                                                                                                                                                                                                        |
| Rx S1 Byte                          | Displays the received S1 byte and its decoded QL value.                                                                                                                                                                                                                                                                                                                                                                                                                     |
| Tx S1 Byte                          | Displays the transmitted S1 byte and its decoded QL value.                                                                                                                                                                                                                                                                                                                                                                                                                  |
| Tx DUS/DNU                          | Displays whether the QL value is forcibly set to QL-DUS/QL-DNU.                                                                                                                                                                                                                                                                                                                                                                                                             |
| Single Fiber Mode : No              | Clock Mode :synchronous                                                                                                                                                                                                                                                                                                                                                                                                                                                     |

B:PE-1# show port 2/1/18 detail

=====  
Ethernet Interface  
=====

```

Description : 10/100/Gig Ethernet SFP
Interface : 2/1/18 Oper Speed : 1 Gbps
Link-level : Ethernet Config Speed : 1 Gbps
Admin State : up Oper Duplex : full
Oper State : up Config Duplex : full
Physical Link : Yes MTU : 1518
Single Fiber Mode : No Min Frame Length : 64 Bytes
IfIndex : 69795840 Hold time up : 0 seconds
Last State Change : 08/21/2012 21:47:08 Hold time down : 0 seconds
Last Cleared Time : N/A DDM Events : Enabled
Phys State Chng Cnt: 7

Configured Mode : access Encap Type : 802.1q
Dot1Q Ethertype : 0x8100 QinQ Ethertype : 0x8100
PBB Ethertype : 0x88e7
Ing. Pool % Rate : 100 Egr. Pool % Rate : 100
Ing. Pool Policy : n/a
Egr. Pool Policy : n/a
Net. Egr. Queue Pol: default
Egr. Sched. Pol : n/a
Auto-negotiate : true MDI/MDX : unknown
Accounting Policy : None Collect-stats : Disabled
Egress Rate : Default Ingress Rate : Default
Load-balance-algo : Default LACP Tunnel : Disabled

```

## Port Show Commands

```

Down-when-looped : Disabled
Loop Detected : False
Use Broadcast Addr : False

Sync. Status Msg. : Disabled
Tx DUS/DNU : Disabled
SSM Code Type : sdh

Down On Int. Error : Disabled

CRC Mon SD Thresh : Disabled
CRC Mon SF Thresh : Disabled

Configured Address : 00:03:fa:1b:bb:3f
Hardware Address : 00:03:fa:1b:bb:3f

Transceiver Data

Transceiver Type : SFP
Model Number : 3HE00027AAAA02 ALA IPUIAELDAB
TX Laser Wavelength: 850 nm
Connector Code : LC
Manufacture date : 2008/09/25
Serial Number : PED38UH
Part Number : FTRJ8519P2BNL-A5
Optical Compliance : GIGE-SX
Link Length support: 300m for OM2 50u MMF; 150m for OM1 62.5u MMF
=====
Transceiver Digital Diagnostic Monitoring (DDM), Internally Calibrated
=====
 Value High Alarm High Warn Low Warn Low Alarm

Temperature (C) +25.9 +95.0 +90.0 -20.0 -25.0
Supply Voltage (V) 3.32 3.90 3.70 2.90 2.70
Tx Bias Current (mA) 8.1 17.0 14.0 2.0 1.0
Tx Output Power (dBm) -4.49 -2.00 -2.00 -11.02 -11.74
Rx Optical Power (avg dBm) -5.16 1.00 -1.00 -18.01 -20.00
=====
Traffic Statistics
=====
 Input Output

Octets 0 0
Packets 0 0
Errors 0 0
=====
Ethernet Statistics
=====
Broadcast Pckts : 0 Drop Events : 0
Multicast Pckts : 0 CRC/Align Errors : 0
Undersize Pckts : 0 Fragments : 0
Oversize Pckts : 0 Jabbers : 0
Collisions : 0

Octets : 0
Packets : 0
Packets of 64 Octets : 0
Packets of 65 to 127 Octets : 0

```

## Interface Configuration

```

Packets of 128 to 255 Octets : 0
Packets of 256 to 511 Octets : 0
Packets of 512 to 1023 Octets : 0
Packets of 1024 to 1518 Octets : 0
Packets of 1519 or more Octets : 0
=====

```

### Port Statistics

```

=====
Input Output

Unicast Packets 0 0
Multicast Packets 0 0
Broadcast Packets 0 0
Discards 0 0
Unknown Proto Discards 0
=====

```

### Ethernet-like Medium Statistics

```

=====
Alignment Errors : 0 Sngl Collisions : 0
FCS Errors : 0 Mult Collisions : 0
SQE Test Errors : 0 Late Collisions : 0
CSE : 0 Excess Collisns : 0
Too long Frames : 0 Int MAC Tx Errs : 0
Symbol Errors : 0 Int MAC Rx Errs : 0
In Pause Frames : 0 Out Pause Frames : 0
=====

```

### Per Threshold MDA Discard Statistics

```

=====
Packets Octets

Threshold 0 Dropped : 0 0
Threshold 1 Dropped : 0 0
Threshold 2 Dropped : 0 0
Threshold 3 Dropped : 0 0
Threshold 4 Dropped : 0 0
Threshold 5 Dropped : 0 0
Threshold 6 Dropped : 0 0
Threshold 7 Dropped : 0 0
Threshold 8 Dropped : 0 0
Threshold 9 Dropped : 0 0
Threshold 10 Dropped : 0 0
Threshold 11 Dropped : 0 0
Threshold 12 Dropped : 0 0
Threshold 13 Dropped : 0 0
Threshold 14 Dropped : 0 0
Threshold 15 Dropped : 0 0
=====

```

B:PE-1#

\*A:sne# show port 1/1/4 vport statistics

Port 1/1/4 Access Egress vport

## Port Show Commands

```
=====
VPort Name : vpl
Description : (Not Specified)
Sched Policy : portschedpoll
Rate Limit : Max
Rate Modify : disabled
Modify delta : 0
Vport Queuing Statistics

Last Cleared Time : N/A

 Packets Octets
Forwarded: 0
Dropped : 0

Vport per Level Queuing Statistics

 Packets Octets
Level : 8
Forwarded: 0
Dropped : 0
Level : 7
Forwarded: 0
Dropped : 0
Level : 6
Forwarded: 0
Dropped : 0
Level : 5
Forwarded: 0
Dropped : 0
Level : 4
Forwarded: 0
Dropped : 0
Level : 3
Forwarded: 0
Dropped : 0
Level : 2
Forwarded: 0
Dropped : 0
Level : 1
Forwarded: 0
Dropped : 0

Host-Matches

Dest: dslaml

=====
*A:sne#
```

**Ethernet Output** — The following table describes the output fields.

| Label            | Description                                                                                                                                                                                                                                                                                                                                                                                                                                                                                                        |
|------------------|--------------------------------------------------------------------------------------------------------------------------------------------------------------------------------------------------------------------------------------------------------------------------------------------------------------------------------------------------------------------------------------------------------------------------------------------------------------------------------------------------------------------|
| Broadcast Pckts  | <p>The number of packets, delivered by this sub-layer to a higher (sub-) layer, which were addressed to a broadcast address at this sub-layer.</p> <p>The total number of packets that higher-level protocols requested be transmitted, and which were addressed to a multicast address at this sub-layer, including those that were discarded or not sent.</p> <p>For a MAC layer protocol, this includes both Group and Functional addresses.</p>                                                                |
| Multicast Pckets | <p>The number of packets, delivered by this sub-layer to a higher (sub-) layer, which were addressed to a multicast address at this sub-layer. For a MAC layer protocol, this includes both Group and Functional addresses. The total number of packets that higher-level protocols requested be transmitted, and which were addressed to a multicast address at this sub-layer, including those that were discarded or not sent. For a MAC layer protocol, this includes both Group and Functional addresses.</p> |
| Undersize Pckets | <p>The total number of packets received that were less than 64 octets long (excluding framing bits, but including FCS octets) and were otherwise well formed.</p>                                                                                                                                                                                                                                                                                                                                                  |
| Oversize Pckts   | <p>The total number of packets received that were longer than can be accepted by the physical layer of that port (9900 octets excluding framing bits, but including FCS octets for GE ports) and were otherwise well formed.</p>                                                                                                                                                                                                                                                                                   |
| Collisions       | <p>The best estimate of the total number of collisions on this Ethernet segment.</p>                                                                                                                                                                                                                                                                                                                                                                                                                               |
| Drop Events      | <p>The total number of events in which packets were dropped by the probe due to lack of resources. Note that this number is not necessarily the number of packets dropped; it is just the number of times this condition has been detected.</p>                                                                                                                                                                                                                                                                    |
| CRC Align Errors | <p>The total number of packets received that had a length (excluding framing bits, but including FCS octets) of between 64 and 1518 octets, inclusive, but had either a bad Frame Check Sequence (FCS) with an integral number of octets (FCS Error) or a bad FCS with a non-integral number of octets (Alignment Error).</p>                                                                                                                                                                                      |
| Fragments        | <p>The total number of packets received that were less than 64 octets in length (excluding framing bits but including FCS octets) and had either a bad Frame Check Sequence (FCS) with an integral number of octets (FCS Error) or a bad FCS with a non-integral number of octets (Alignment Error).</p>                                                                                                                                                                                                           |
| Jabbers          | <p>The total number of packets received that were longer than 1518 octets (excluding framing bits, but including FCS octets), and had either a bad Frame Check Sequence (FCS) with an integral number of octets (FCS Error) or a bad FCS with a non-integral number of octets (Alignment Error).</p>                                                                                                                                                                                                               |

## Port Show Commands

| Label             | Description (Continued)                                                                                                                                          |
|-------------------|------------------------------------------------------------------------------------------------------------------------------------------------------------------|
| Ingress Pool Size | The amount of ingress buffer space, expressed as a percentage of the available buffer space that will be allocated to the port or channel for ingress buffering. |
| Octets            | The total number of octets received.                                                                                                                             |
| Packets           | The total number of packets received.                                                                                                                            |
| Packets to        | The number of packets received that were equal to or less than the displayed octet limit.                                                                        |

### Sample Output

```
=====
Ethernet Statistics
=====
```

|                |   |       |                  |   |   |
|----------------|---|-------|------------------|---|---|
| Broadcast Pkts | : | 42621 | Drop Events      | : | 0 |
| Multicast Pkts | : | 0     | CRC/Align Errors | : | 0 |
| Undersize Pkts | : | 0     | Fragments        | : | 0 |
| Oversize Pkts  | : | 0     | Jabbers          | : | 0 |
| Collisions     | : | 0     |                  |   |   |

|                                |   |         |
|--------------------------------|---|---------|
| Octets                         | : | 2727744 |
| Packets                        | : | 42621   |
| Packets of 64 Octets           | : | 42621   |
| Packets of 65 to 127 Octets    | : | 0       |
| Packets of 128 to 255 Octets   | : | 0       |
| Packets of 256 to 511 Octets   | : | 0       |
| Packets of 512 to 1023 Octets  | : | 0       |
| Packets of 1024 to 1518 Octets | : | 0       |
| Packets of 1519 or more Octets | : | 0       |

```
=====
Port Statistics
=====
```

|                        | Input | Output |
|------------------------|-------|--------|
| Unicast Packets        | 0     | 0      |
| Multicast Packets      | 0     | 0      |
| Broadcast Packets      | 42621 | 0      |
| Discards               | 0     | 0      |
| Unknown Proto Discards | 0     | 0      |

```
=====
...
=====
```

**Ethernet-like Medium Statistics Output** — The following table describes Ethernet-like medium statistics output fields.

| Label            | Description                                                                                                                                                                                                                                                                                          |
|------------------|------------------------------------------------------------------------------------------------------------------------------------------------------------------------------------------------------------------------------------------------------------------------------------------------------|
| Alignment Errors | The total number of packets received that had a length (excluding framing bits, but including FCS octets) of between 64 and 1518 octets, inclusive, but had either a bad Frame Check Sequence (FCS) with an integral number of octets (FCS Error) or a bad FCS with a non-integral number of octets. |
| FCS Errors       | The number of frames received on a particular interface that are an integral number of octets in length but do not pass the FCS check.                                                                                                                                                               |
| SQE Errors       | The number of times that the SQE TEST ERROR is received on a particular interface.                                                                                                                                                                                                                   |
| CSE              | The number of times that the carrier sense condition was lost or never asserted when attempting to transmit a frame on a particular interface.                                                                                                                                                       |
| Too long Frames  | The number of frames received on a particular interface that exceed the maximum permitted frame size.                                                                                                                                                                                                |
| Symbol Errors    | For an interface operating at 100 Mb/s, the number of times there was an invalid data symbol when a valid carrier was present.                                                                                                                                                                       |
| Sngl Collisions  | The number of frames that are involved in a single collision, and are subsequently transmitted successfully.                                                                                                                                                                                         |
| Mult Collisions  | The number of frames that are involved in more than one collision and are subsequently transmitted successfully.                                                                                                                                                                                     |
| Late Collisions  | The number of times that a collision is detected on a particular interface later than one slotTime into the transmission of a packet.                                                                                                                                                                |
| Excess Collisns  | The number of frames for which transmission on a particular interface fails due to excessive collisions.                                                                                                                                                                                             |
| Int MAC Tx Errs  | The number of frames for which transmission on a particular interface fails due to an internal MAC sublayer transmit error,                                                                                                                                                                          |
| Int MAC Rx Errs  | The number of frames for which reception on a particular interface fails due to an internal MAC sublayer receive error.                                                                                                                                                                              |

### Sample Output

```
A:ALA-48# show port 1/3/1 detail
=====
...
=====
Ethernet-like Medium Statistics
=====
```

## Port Show Commands

```

Alignment Errors : 0 Sngl Collisions : 0
FCS Errors : 0 Mult Collisions : 0
SQE Test Errors : 0 Late Collisions : 0
CSE : 0 Excess Collisns : 0
Too long Frames : 0 Int MAC Tx Errs : 0
Symbol Errors : 0 Int MAC Rx Errs : 0
Queue Statistics

```

```

=====
Ingress Queue 1 Packets Octets
 In Profile forwarded : 0 0
 In Profile dropped : 0 0
 Out Profile forwarded : 0 0
 Out Profile dropped : 0 0
Ingress Queue 2 Packets Octets
 In Profile forwarded : 0 0
 In Profile dropped : 0 0
 Out Profile forwarded : 0 0
 Out Profile dropped : 0 0
Ingress Queue 3 Packets Octets
 In Profile forwarded : 0 0
 In Profile dropped : 0 0
 Out Profile forwarded : 0 0
 Out Profile dropped : 0 0
Ingress Queue 4 Packets Octets
 In Profile forwarded : 0 0
 In Profile dropped : 0 0
 Out Profile forwarded : 0 0
 Out Profile dropped : 0 0
Ingress Queue 5 Packets Octets
 In Profile forwarded : 0 0
 In Profile dropped : 0 0
 Out Profile forwarded : 0 0
 Out Profile dropped : 0 0
Ingress Queue 6 Packets Octets
 In Profile forwarded : 0 0
 In Profile dropped : 0 0
 Out Profile forwarded : 0 0
 Out Profile dropped : 0 0
=====

```

### Per Threshold MDA Discard Statistics

```

=====

Packets Octets

Threshold 0 Dropped : 0 0
Threshold 1 Dropped : 0 0
Threshold 2 Dropped : 0 0
Threshold 3 Dropped : 0 0
Threshold 4 Dropped : 0 0
Threshold 5 Dropped : 0 0
Threshold 6 Dropped : 0 0
Threshold 7 Dropped : 0 0
Threshold 8 Dropped : 0 0
Threshold 9 Dropped : 0 0
Threshold 10 Dropped : 0 0
Threshold 11 Dropped : 0 0
Threshold 12 Dropped : 0 0

```

## Interface Configuration

|                        |   |   |
|------------------------|---|---|
| Threshold 13 Dropped : | 0 | 0 |
| Threshold 14 Dropped : | 0 | 0 |
| Threshold 15 Dropped : | 0 | 0 |

=====  
A:ALA-48#

**Port Associations Output** — The following table describes port associations output fields.

| Label       | Description                                                             |
|-------------|-------------------------------------------------------------------------|
| Svc ID      | The service identifier.                                                 |
| Name        | The name of the IP interface.                                           |
| Encap Value | The dot1q or qinq encapsulation value on the port for this IP interface |

**Sample Output**

```
A:ALA-1# show port 1/1/6 associations
=====
Interface Table
=====
Router/ServiceId Name Encap Val

Router: Base if1000 1000
Router: Base if2000 2000

Interfaces
=====
A:ALA-1#
```

**Port Frame Relay Output** — The following table describes port Frame Relay output fields.

| Label               | Description                                                                                                                                                                                    |
|---------------------|------------------------------------------------------------------------------------------------------------------------------------------------------------------------------------------------|
| Mode                | Displays the mode of the interface. It can be set as Data terminal equipment (dte) or Data circuit-terminating equipment (DCE).                                                                |
| LMI Type            | Displays the LMI type.                                                                                                                                                                         |
| FR Interface Status | Displays the status of the Frame Relay interface as determined by the performance of the dlcmi. If no DLCMI is running, the Frame Relay interface will stay in the running state indefinitely. |

**Sample Output**

```
A:ALA-49>config>port# show port 8/1/2 frame-relay
=====
Frame Relay Info for 8/1/2
=====
Mode : dte LMI Type : itu
FR Interface Status : fault
N391 DTE : 6 N392 DCE : 3
N392 DTE : 3 N393 DCE : 4
N393 DTE : 4 T392 DCE : 15
T391 DTE : 10
Tx Status Enquiry : 0 Rx Status Enquiry : 0
```

```

Rx Status Messages : 0 Tx Status Messages : 0
Status Message Timeouts : 0 Status Enquiry Timeouts : 0
Discarded Messages : 0 Inv. RxSeqNum Messages : 0
=====

```

```
A:ALA-49>config>port#
```

## Sample Output

```

*A:PE>config>port>ethernet>dot1x# show port 1/1/5 dot1x
=====
802.1x Port Status
=====

Port control : auto
Port status : authorized
Authenticator PAE state : authenticated
Backend state : idle
Reauth enabled : no Reauth period : N/A
Max auth requests : 2 Transmit period : 30
Supplicant timeout : 30 Server timeout : 30
Quiet period : 60
Radius-plcy : test
Tunneling : false

=====
802.1x Session Statistics
=====

authentication method : remote-radius
last session id : PAC-02228000-11B0A9BB
last session time : 00h00m06s
last session username : user1
last session term cause : N/A
user tx octets : 0 user tx frames : 0
user rx octets : 0 user rx frames : 0

*A:Dut-C>config>port>ethernet>dot1x# /show port 1/1/5 dot1x detail
=====
802.1x Port Status
=====

Port control : auto
Port status : authorized
Authenticator PAE state : authenticated
Backend state : idle
Reauth enabled : no Reauth period : N/A
Max auth requests : 2 Transmit period : 30
Supplicant timeout : 30 Server timeout : 30
Quiet period : 60
Radius-plcy : test
Tunneling : false

=====
802.1x Session Statistics
=====

```

## Port Show Commands

```
=====
authentication method : remote-radius
last session id : PAC-02228000-11B0A9BB
last session time : 00h00m10s
last session username : user1
last session term cause : N/A
user tx octets : 0 user tx frames : 0
user rx octets : 0 user rx frames : 0
=====

802.1x Authentication Statistics
=====

tx frames : 22 rx frames : 14
tx req/id frames : 6 rx resp/id frames : 3
tx request frames : 3 rx response frames : 3
rx start frames : 4 rx logoff frames : 4
rx unknown frame type : 0 rx bad eap length : 0
rx last version : 1 rx last source mac : 00:01:02:17:23:22
=====

802.1x Authentication Diagnostics
=====

Enters Connecting : 6
EapLogoffs While Connecting : 1
Logoffs While Connecting : 1
Success While Authenticating : 3
Timeouts While Authenticating : 0
Failures While Authenticating : 0
Reauths While Authenticating : 0
EapStarts While Authenticating : 0
EapLogoffs While Authenticating : 0
Reauths While Authenticated : 0
EapStarts While Authenticated : 0
EapLogoffs While Authenticated : 1
Backend Responses : 6
Backend Access Challenges : 3
Backend Requests To Supplicant : 3
Backend Access Challenges : 0
Backend Non Nak Responses : 0
Backend Auth Successes : 3
Backend Auth Failures : 0
```

## ethernet efm-oam

**Syntax** ethernet efm-oam

**Context** show>port

**Description** This command shows EFM-OAM port state information.

**Sample Output**

```
config port 1/1/1 ethernet efm-oam ignore-efm-state
show port 1/1/1 ethernet efm-oam
```

```
=====
Ethernet Oam (802.3ah)
=====
```

```
Admin State : down
Oper State : disabled
Mode : active
Pdu Size : 1518
Config Revision : 0
Function Support : LB
Transmit Interval : 1000 ms
Multiplier : 5
Hold Time : 0
Tunneling : false
Loop Detected : false
```

```
No Peer Information Available
```

```
Loopback State : None
Loopback Ignore Rx : Ignore
Ignore Efm State : true
```

```
config port 1/1/1 ethernet efm-oam noignore-efm-state
show port 1/1/1 ethernet efm-oam
```

```
=====
Ethernet Oam (802.3ah)
=====
```

```
Admin State : down
Oper State : disabled
Mode : active
Pdu Size : 1518
Config Revision : 0
Function Support : LB
Transmit Interval : 1000 ms
Multiplier : 5
Hold Time : 0
Tunneling : false
Loop Detected : false
```

```
No Peer Information Available
```

```
Loopback State : None
Loopback Ignore Rx : Ignore
Ignore Efm State : false
```

## Port Show Commands

```

=====
Ethernet Oam Statistics
=====
 Input Output

Information 0 0
Loopback Control 0 0
Unsupported Codes 0 0
Frames Lost 0 0
=====

```

When the optional **ignore-efm-state** command is set to default [no] and the port enters a Link Up condition as a result of an 802.3ah fault condition, a reason code is included on the show port to indicate the reason the port entered the link up.

```

show port
=====
Ports on Slot 1
=====
Port Admin Link Port Cfg Oper LAG/ Port Port Port C/QS/S/XFP/
Id State State State MTU MTU Bndl Mode Encp Type MDIMDX

1/1/1 Down No Down 1578 1578 - netw null xcme
1/1/2 Up Yes Up 9212 9212 5 netw null xcme
1/1/3 Down No Down 1578 1578 - netw null xcme
1/1/4 Down No Down 1578 1578 - netw null xcme
1/1/5 Up No Down 1522 1522 - accs qinq xcme
1/1/6 Down No Down 1578 1578 - netw null xcme
1/1/7 Down No Down 1578 1578 - netw null xcme
1/1/8 Down No Down 1578 1578 - netw null xcme
1/1/9 Down No Down 1578 1578 - netw null xcme
1/1/10 Up Yes Link Up 1518 1518 - accs dotq xcme ? Sample (remains unchanged)

```

Further examination of the individual port reveals the reason code for the Link Up condition.

```

mep# show port 1/1/10
=====
Ethernet Interface
=====
Description : 10/100/Gig Ethernet SFP
Interface : 1/1/10 Oper Speed : N/A
Link-level : Ethernet Config Speed : 1 Gbps
Admin State : up Oper Duplex : N/A
Oper State : down Config Duplex : full
Reason Down : efmOamDown
Physical Link : Yes MTU : 1518
Single Fiber Mode : No
IfIndex : 35979264 Hold time up : 0 seconds
Last State Change : 08/08/2011 21:56:20 Hold time down : 0 seconds
Last Cleared Time : N/A DDM Events : Enabled

Configured Mode : access Encap Type : 802.1q
Dot1Q Ethertype : 0x8100 QinQ Ethertype : 0x8100
PBB Ethertype : 0x88e7
Ing. Pool % Rate : 100 Egr. Pool % Rate : 100
Ing. Pool Policy : n/a
Egr. Pool Policy : n/a

```

```

Net. Egr. Queue Pol: default
Egr. Sched. Pol : n/a
Auto-negotiate : true
Accounting Policy : None
Egress Rate : Default
Load-balance-algo : default
MDI/MDX : unknown
Collect-stats : Disabled
Ingress Rate : Default
LACP Tunnel : Disabled

Down-when-looped : Disabled
Loop Detected : False
Use Broadcast Addr : False
Keep-alive : 10
Retry : 120

Sync. Status Msg. : Disabled
Tx DUS/DNU : Disabled
SSM Code Type : sdh
Rx Quality Level : N/A
Tx Quality Level : N/A

Configured Address : 90:f4:01:01:00:0a
Hardware Address : 90:f4:01:01:00:0a
Cfg Alarm :
Alarm Status :
=====

```

## dot1x

**Syntax** **dot1x [detail]**

**Context** show>port>ethernet

**Description** This command displays 802.1x information.

**Parameters** **detail** — Displays detailed information.

### Sample Output

```
*A:PE>config>port>ethernet>dot1x# show port 1/1/5 dot1x
```

```
=====
802.1x Port Status
=====
```

```

Port control : auto
Port status : authorized
Authenticator PAE state : authenticated
Backend state : idle
Reauth enabled : no
Max auth requests : 2
Supplicant timeout : 30
Quiet period : 60
Radius-plcy : test
Tunneling : false
Reauth period : N/A
Transmit period : 30
Server timeout : 30

```

```
=====
802.1x Session Statistics
=====
```

```

authentication method : remote-radius
last session id : PAC-02228000-11B0A9BB

```

## Port Show Commands

```
last session time : 00h00m06s
last session username : user1
last session term cause : N/A
user tx octets : 0 user tx frames : 0
user rx octets : 0 user rx frames : 0
```

## lldp

**Syntax** **lldp** [**nearest-bridge**|**nearest-non-tpmr**|**nearest-customer**] [**remote-info**] [**detail**]

**Context** show>port>ethernet

**Description** This command displays Link Layer Discovery Protocol (LLDP) information.

**Parameters**

- nearest-bridge** — Displays nearest bridge information.
- nearest-non-tpmr** — Displays nearest Two-Port MAC Relay (TPMR) information.
- nearest-customer** — Displays nearest customer information.
- remote-info** — Displays remote information on the bridge MAC.
- detail** — Shows detailed information.

### Sample Output

```
A:testSr1# show port 1/2/2 ethernet lldp
=====
Link Layer Discovery Protocol (LLDP) Port Information
=====
Port 1/2/2 Bridge nearest-bridge

Admin State : txAndRx Notifications : Disabled
Transmit TLVs : portDesc sysCap

Management Address Transmit Configuration:
Index 1 (system) : Enabled Address : 10.20.30.40

Port 1/2/2 Bridge nearest-non-tpmr

Admin State : disabled Notifications : Disabled
Transmit TLVs : None

Management Address Transmit Configuration:
Index 1 (system) : Disabled Address : 10.20.30.40

Port 1/2/2 Bridge nearest-customer

Admin State : disabled Notifications : Disabled
Transmit TLVs : None

Management Address Transmit Configuration:
Index 1 (system) : Disabled Address : 10.20.30.40
=====
A:testSr1#
```

```

A:testSrl# show port 1/2/2 ethernet lldp nearest-bridge detail
=====
Link Layer Discovery Protocol (LLDP) Port Information
=====
Port 1/2/2 Bridge nearest-bridge

Admin State : txAndRx Notifications : Disabled
Transmit TLVs : portDesc sysCap

Management Address Transmit Configuration:
Index 1 (system) : Enabled Address : 10.20.30.40

Port LLDP Stats:
Tx Frames : 13 Tx Length Err Frames : 0
Rx Frames : 0 Rx Frame Discard : 0
Rx Frame Errors : 0 Rx TLV Discard : 0
Rx TLV Unknown : 0 Rx Ageouts : 0
=====
A:testSrl#

A:testSrl# show port 1/2/2 ethernet lldp nearest-bridge remote-info detail
=====
Link Layer Discovery Protocol (LLDP) Port Information
=====
Port 1/2/2 Bridge nearest-bridge Remote Peer Information

Remote Peer Index 2 at timestamp 12/02/2008 16:08:14:
Supported Caps : (Not Specified)
Enabled Caps : (Not Specified)
Chassis Id Subtype : 4 (macAddress)
Chassis Id : ac:fa:ff:00:00:00
PortId Subtype : 7 (local)
Port Id : 37814272
Port Description : n/a
System Name : n/a
System Description : n/a

Remote Peer Index 2 management addresses at time 12/02/2008 16:08:14:
No remote management addresses found
=====
A:testSrl#

```

## port-tree

**Syntax** `port-tree port-id`

**Context** show

**Description** This command displays the treeWAN PHY mode (xgig wan) Ethernet ports.

**Parameters** *port-id* — Specifies the physical port ID.

## Port Show Commands

|                    |                                    |                                                         |
|--------------------|------------------------------------|---------------------------------------------------------|
| <b>Syntax</b>      | port-id                            | <i>slot[/mda[/port]] or<br/>slot/mda/port[.channel]</i> |
| <b>MDA Values</b>  |                                    | 1—2                                                     |
| <b>Slot Values</b> |                                    | 1—10                                                    |
| <b>Port Values</b> | 1 — 60 (depending on the MDA type) |                                                         |

Output **Show Port Tree Output** — The following table describes show port tree output fields.

| Label           | Description                                                                       |
|-----------------|-----------------------------------------------------------------------------------|
| ifIndex         | Displays the interface's index number which reflects its initialization sequence. |
| type            | Specifies the type.                                                               |
| sonet-sdh-index | Specifies the sonet-sdh-index.                                                    |
| *               | When a * is displayed after the sonet-sdh-index, the port/channel is provisioned. |

### Sample Output

```
*A:7950 XRS-20# show port-tree 1/1/5

 ifIndex type, sonet-sdh-index (* = provisioned)
 =====
 35815424 Port, N/A *
 572686341 STS192, none *
```

## redundancy

**Syntax** redundancy

**Context** show

**Description** This command enables the context to show multi-chassis redundancy information.

## multi-chassis

**Syntax** multi-chassis all  
multi-chassis mc-lag peer *ip-address* [**lag** *lag-id*]  
multi-chassis mc-lag [**peer** *ip-address* [**lag** *lag-id*]] **statistics**  
multi-chassis sync [**peer** *ip-address*] [**detail**]  
multi-chassis sync [**peer** *ip-address*] **statistics**

**Context** show>redundancy

- Description** This command displays multi-chassis redundancy information.
- Parameters**
- all** — Displays all multi-chassis information.
  - mc-lag** — Displays multi-chassis LAG information.
  - peer ip-address** — Displays the address of the multi-chassis peer.
  - lag lag-id** — Displays the specified LAG ID on this system that forms an multi-chassis LAG configuration with the indicated peer.
  - statistics** — Displays statistics for the multi-chassis peer.
  - sync** — Displays synchronization information.
  - detail** — Displays detailed information.

### Sample Output

```
A:pc1# show redundancy multi-chassis all
=====
Multi-Chassis Peers
=====
Peer IP Src IP Auth Peer Admin
 MCS Admin MCS Oper MCS State MC-LAG Admin MC-LAG Oper

10.10.10.102 10.10.10.101 hash Enabled
 Enabled Enabled inSync Enabled Enabled
10.10.20.1 0.0.0.0 None Disabled
 -- -- -- Disabled Disabled
=====
A:pc1#
```

```
*A:Dut-C# show redundancy multi-chassis mc-lag peer 10.10.10.1
=====
Multi-Chassis MC-Lag Peer 10.10.10.1
=====
Last State chg: 09/24/2007 07:58:03
Admin State: Up Oper State : Up
KeepAlive: 10 deci-seconds Hold On Ngbr Failure : 3

Lag Id LACP Key Remote Lag Id System Id Sys Prio Last State Changed

1 326661 00:00:00:33:33:33 32888 09/24/2007 07:56:35

Number of LAGs : 1
=====
*A:Dut-C#
```

```
A:pc1# show redundancy multi-chassis mc-lag statistics
=====
Multi-Chassis Statistics
=====
Packets Rx : 129816
Packets Rx Keepalive : 129798
Packets Rx Config : 3
```

## Port Show Commands

```
Packets Rx Peer Config : 5
Packets Rx State : 10
Packets Dropped KeepaliveTask : 0
Packets Dropped Packet Too Short : 0
Packets Dropped Verify Failed : 0
Packets Dropped Tlv Invalid Size : 0
Packets Dropped Out of Seq : 0
Packets Dropped Unknown Tlv : 0
Packets Dropped Tlv Invalid LagId : 0
Packets Dropped MD5 : 0
Packets Dropped Unknown Peer : 0
Packets Tx : 77918
Packets Tx Keepalive : 77879
Packets Tx Config : 6
Packets Tx Peer Config : 26
Packets Tx State : 7
Packets Tx Failed : 0
=====
A:pl1#
A:pl1# show redundancy multi-chassis mc-lag peer 10.10.10.102 lag 2 statistics
=====
Multi-Chassis Statistics, Peer 10.10.10.102 Lag 2
=====
Packets Rx Config : 1
Packets Rx State : 4
Packets Tx Config : 2
Packets Tx State : 3
Packets Tx Failed : 0
=====
A:pl1#

A:pl1#show redundancy multi-chassis mc-lag peer 10.10.10.102 statistics
=====
Multi-Chassis Statistics, Peer 10.10.10.102
=====
Packets Rx : 129918
Packets Rx Keepalive : 129900
Packets Rx Config : 3
Packets Rx Peer Config : 5
Packets Rx State : 10
Packets Dropped State Disabled : 0
Packets Dropped Packets Too Short : 0
Packets Dropped Tlv Invalid Size : 0
Packets Dropped Tlv Invalid LagId : 0
Packets Dropped Out of Seq : 0
Packets Dropped Unknown Tlv : 0
Packets Dropped MD5 : 0
Packets Tx : 77979
Packets Tx Keepalive : 77940
Packets Tx Peer Config : 26
Packets Tx Failed : 0
=====
A:pl1#

A:pl1# show redundancy multi-chassis sync
=====
Multi-chassis Peer Table
```

```

=====
Peer

Peer IP Address : 10.10.10.102
Description : CO1
Authentication : Enabled
Source IP Address : 10.10.10.101
Admin State : Enabled

Sync-status

Client Applications :
Sync Admin State : Up
Sync Oper State : Up
DB Sync State : inSync
Num Entries : 0
Lcl Deleted Entries : 0
Alarm Entries : 0
Rem Num Entries : 0
Rem Lcl Deleted Entries : 0
Rem Alarm Entries : 0
=====
Peer

Peer IP Address : 10.10.20.1
Authentication : Disabled
Source IP Address : 0.0.0.0
Admin State : Disabled
=====
A:pcl#

pcl# show redundancy multi-chassis sync peer 10.10.10.102
=====
Multi-chassis Peer Table
=====
Peer

Peer IP Address : 10.10.10.102
Description : CO1
Authentication : Enabled
Source IP Address : 10.10.10.101
Admin State : Enabled

Sync-status

Client Applications :
Sync Admin State : Up
Sync Oper State : Up
DB Sync State : inSync
Num Entries : 0
Lcl Deleted Entries : 0
Alarm Entries : 0
Rem Num Entries : 0
Rem Lcl Deleted Entries : 0
Rem Alarm Entries : 0
=====
MCS Application Stats
=====
Application : igmp

```

## Port Show Commands

```
Num Entries : 0
Lcl Deleted Entries : 0
Alarm Entries : 0

Rem Num Entries : 0
Rem Lcl Deleted Entries : 0
Rem Alarm Entries : 0

Application : igmpSnooping
Num Entries : 0
Lcl Deleted Entries : 0
Alarm Entries : 0

Rem Num Entries : 0
Rem Lcl Deleted Entries : 0
Rem Alarm Entries : 0

Application : subMgmt
Num Entries : 0
Lcl Deleted Entries : 0
Alarm Entries : 0

Rem Num Entries : 0
Rem Lcl Deleted Entries : 0
Rem Alarm Entries : 0

Application : srrp
Num Entries : 0
Lcl Deleted Entries : 0
Alarm Entries : 0

Rem Num Entries : 0
Rem Lcl Deleted Entries : 0
Rem Alarm Entries : 0
=====
A:pcl#

A:pcl# show redundancy multi-chassis sync peer 10.10.10.102 detail
=====
Multi-chassis Peer Table
=====
Peer

Peer IP Address : 10.10.10.102
Description : CO1
Authentication : Enabled
Source IP Address : 10.10.10.101
Admin State : Enabled

Sync-status

Client Applications :
Sync Admin State : Up
Sync Oper State : Up
DB Sync State : inSync
Num Entries : 0
Lcl Deleted Entries : 0
Alarm Entries : 0
```

```

Rem Num Entries : 0
Rem Lcl Deleted Entries : 0
Rem Alarm Entries : 0
=====
MCS Application Stats
=====
Application : igmp
Num Entries : 0
Lcl Deleted Entries : 0
Alarm Entries : 0

Rem Num Entries : 0
Rem Lcl Deleted Entries : 0
Rem Alarm Entries : 0

Application : igmpSnooping
Num Entries : 0
Lcl Deleted Entries : 0
Alarm Entries : 0

Rem Num Entries : 0
Rem Lcl Deleted Entries : 0
Rem Alarm Entries : 0

Application : subMgmt
Num Entries : 0
Lcl Deleted Entries : 0
Alarm Entries : 0

Rem Num Entries : 0
Rem Lcl Deleted Entries : 0
Rem Alarm Entries : 0

Application : srrp
Num Entries : 0
Lcl Deleted Entries : 0
Alarm Entries : 0

Rem Num Entries : 0
Rem Lcl Deleted Entries : 0
Rem Alarm Entries : 0
=====
Ports synced on peer 10.10.10.102
=====
Port/Encap Tag

1/1/1
 1-2 r1
=====
A:pl1#

A:pl1# show redundancy multi-chassis sync statistics
=====
Multi-chassis Peer Sync Stats
=====
Peer IP Address : 10.10.10.102
Packets Tx Total : 511
Packets Tx Hello : 510

```

## Port Show Commands

```
Packets Tx Data : 0
Packets Tx Other : 1
Packets Tx Error : 0
Packets Rx Total : 511
Packets Rx Hello : 510
Packets Rx Data : 0
Packets Rx Other : 1
Packets Rx Error : 0
Packets Rx Header Err : 0
Packets Rx Body Err : 0
Packets Rx Seq Num Err : 0
=====
Peer IP Address : 10.10.20.1
Packets Tx Total : 0
Packets Tx Hello : 0
Packets Tx Data : 0
Packets Tx Other : 0
Packets Tx Error : 0
Packets Rx Total : 0
Packets Rx Hello : 0
Packets Rx Data : 0
Packets Rx Other : 0
Packets Rx Error : 0
Packets Rx Header Err : 0
Packets Rx Body Err : 0
Packets Rx Seq Num Err : 0
=====
A:p1#

A:p1# show redundancy multi-chassis sync peer 10.10.10.102 statistics
=====
Multi-chassis Peer Sync Stats
=====
Peer IP Address : 10.10.10.102
Packets Tx Total : 554
Packets Tx Hello : 553
Packets Tx Data : 0
Packets Tx Other : 1
Packets Tx Error : 0
Packets Rx Total : 554
Packets Rx Hello : 553
Packets Rx Data : 0
Packets Rx Other : 1
Packets Rx Error : 0
Packets Rx Header Err : 0
Packets Rx Body Err : 0
Packets Rx Seq Num Err : 0
=====
A:p1#
```

## mc-lag

**Syntax** `mac-lag peer ip-address [lag lag-id]`  
`mac-lag [peer ip-address [lag lag-id]] statistics`

**Context** show>redundancy>multi-chassis

**Description** This command displays multi-chassis LAG information.

### Sample

```
*A:Dut-B# show redundancy multi-chassis mc-lag peer 10.20.1.2
=====
Multi-Chassis MC-Lag Peer 10.20.1.2
=====
Last State chg : 05/17/2009 19:31:58
Admin State : Up Oper State : Up
KeepAlive : 5 deci-seconds Hold On Ngbr Failure : 2

Lag Id LACP Remote Source Oper System Id Sys Last State Changed
Key Lag Id MacLSB MacLSB Prio

1 40000 1 LACP 9c:40 00:02:80:01:00:01 100 05/17/2009 19:31:56

*A:Dut-B# /tools dump redundancy src-bmac-lsb
Src-bmac-lsb: 1025 (04-01) User: B-Vpls - 1 service(s)
Services affected:
B-Vpls: 1
B-Vpls: 2
```

## mc-ring

**Syntax** **mc-ring peer** *ip-address* **statistics**  
**mc-ring peer** *ip-address* [**ring** *sync-tag* [**detail|statistics**] ]  
**mc-ring peer** *ip-address* **ring** *sync-tag* **ring-node** [*ring-node-name* [**detail|statistics**] ]  
**mc-ring global-statistics**

**Context** show>redundancy>multi-chassis

**Description** This command displays multi-chassis ring information.

**Parameters** *ip-address* — Specifies the address of the multi-chassis peer to display.  
**ring** *sync-tag* — Specifies a synchronization tag to be displayed that was used while synchronizing this port with the multi-chassis peer.  
**node** *ring-node-name* — Specifies a ring-node name.  
**global-statistics** — Displays global statistics for the multi-chassis ring.  
**detail** — Displays detailed peer information for the multi-chassis ring.

**Output** **Show mc-ring peer ip-address ring Output** — The following table describes mc-ring peer ip-address ring output fields.

| Label    | Description                                                                                               |
|----------|-----------------------------------------------------------------------------------------------------------|
| Sync Tag | Displays the synchronization tag that was used while synchronizing this port with the multi-chassis peer. |

| Label           | Description (Continued)                                                                                                                                                                                                                                                                                                                                                                                                                                                                                                                                                                                                                                                                                                                                                                                                                                                                                                                                                                                                                                                                                                                                                                                                                                                                                                      |
|-----------------|------------------------------------------------------------------------------------------------------------------------------------------------------------------------------------------------------------------------------------------------------------------------------------------------------------------------------------------------------------------------------------------------------------------------------------------------------------------------------------------------------------------------------------------------------------------------------------------------------------------------------------------------------------------------------------------------------------------------------------------------------------------------------------------------------------------------------------------------------------------------------------------------------------------------------------------------------------------------------------------------------------------------------------------------------------------------------------------------------------------------------------------------------------------------------------------------------------------------------------------------------------------------------------------------------------------------------|
| Oper State      | <p><code>noPeer</code> – The peer has no corresponding ring configured.</p> <p><code>connected</code> – The inband control connection with the peer is operational.</p> <p><code>broken</code> – The inband control connection with the peer has timed out.</p> <p><code>conflict</code> – The inband control connection with the peer has timed out but the physical connection is still OK; the failure of the inband signaling connection is caused by a misconfiguration. For example, a conflict between the configuration of this system and its peer, or a misconfiguration on one of the ring access node systems.</p> <p><code>testingRing</code> – The inband control connection with the peer is being set up. Waiting for result.</p> <p><code>waitingForPeer</code> – Verifying if this ring is configured on the peer.</p> <p><code>configErr</code> – The ring is administratively up, but a configuration error prevents it from operating properly.</p> <p><code>halfBroken</code> – The inband control connection indicates that the ring is broken in one direction (towards the peer).</p> <p><code>localBroken</code> – The inband control connection with the peer is known to be broken due to local failure or local administrative action.</p> <p><code>shutdown</code> – The ring is shutdown.</p> |
| Failure Reason  | Displays the failure reason.                                                                                                                                                                                                                                                                                                                                                                                                                                                                                                                                                                                                                                                                                                                                                                                                                                                                                                                                                                                                                                                                                                                                                                                                                                                                                                 |
| Last Debounce   | Displays the last time that the debounce mechanism (protecting the router from overload situations in case of a flapping ring) was activated.                                                                                                                                                                                                                                                                                                                                                                                                                                                                                                                                                                                                                                                                                                                                                                                                                                                                                                                                                                                                                                                                                                                                                                                |
| Debounce Period | Displays the duration that the debounce mechanism was in action since the “Last Debounce”.                                                                                                                                                                                                                                                                                                                                                                                                                                                                                                                                                                                                                                                                                                                                                                                                                                                                                                                                                                                                                                                                                                                                                                                                                                   |

**Sample Output**

```
*A:ALA-48# show redundancy multi-chassis mc-ring peer 10.0.0.2 ring ring11 detail
=====
Multi-Chassis MC-Ring Detailed Information
=====
Peer : 10.0.0.2
Sync Tag : ring11
Port ID : 1/1/3
Admin State : inService
Oper State : connected
Admin Change : 01/07/2008 21:40:07
Oper Change : 01/07/2008 21:40:24
Last Debounce : 02/15/2008 09:28:42
```

Debounce Period: 0d 00:00:00  
 Failure Reason : None

-----  
 In Band Control Path  
 -----

Service ID : 10  
 Interface Name : to\_an1  
 Oper State : connected  
 Dest IP : 10.10.0.2  
 Src IP : 10.10.0.1  
 -----

VLAN Map B Path Provisioned  
 -----

range 13-13  
 range 17-17  
 -----

VLAN Map Excluded Path Provisioned  
 -----

range 18-18  
 -----

VLAN Map B Path Operational  
 -----

range 13-13  
 range 17-17  
 -----

VLAN Map Excluded Path Operational  
 -----

range 18-18  
 -----

=====  
 \*A:ALA-48#

\*A:ALA-48>show>redundancy>multi-chassis# mc-ring peer 192.251.10.104  
 =====

MC Ring entries  
 =====

| Sync Tag | Oper State | Failure Reason |
|----------|------------|----------------|
|----------|------------|----------------|

-----

No. of MC Ring entries: 0  
 =====

\*A:ALA-48#

\*A:ALA-48# show redundancy multi-chassis mc-ring peer 10.0.0.2  
 =====

MC Ring entries  
 =====

| Sync Tag | Oper State | Failure Reason |
|----------|------------|----------------|
|----------|------------|----------------|

-----

|        |           |      |
|--------|-----------|------|
| ring11 | connected | None |
| ring12 | shutdown  | None |

-----

No. of MC Ring entries: 4  
 =====

\*A:ALA-48#

\*A:ALA-48# show redundancy multi-chassis mc-ring peer 10.0.0.2 ring ring11 ring-node an1  
 detail  
 =====

Multi-Chassis MC-Ring Node Detailed Information

## Port Show Commands

```

=====
Peer : 10.0.0.2
Sync Tag : ring11
Node Name : an1
Oper State Loc : connected
Oper State Rem : notTested
In Use : True
Admin Change : 01/07/2008 21:40:07
Oper Change : 01/07/2008 21:40:25
Failure Reason : None

Ring Node Connectivity Verification

Admin State : inService
Service ID : 11
VLAN Tag : 11
Dest IP : 10.11.3.1
Src IP : None
Interval : 1 minutes
Src MAC : None
=====

*A:ALA-48#

*A:ALA-48# show redundancy multi-chassis mc-ring peer 10.0.0.2 ring ring11 ring-node
=====
MC Ring Node entries
=====
Name Loc Oper St. Failure Reason
 In Use Rem Oper St.

an1 connected None
 Yes notTested
an2 connected None
 Yes notTested

No. of MC Ring Node entries: 2
=====

*A:ALA-48#

```

**Show Redundancy Multi-Chassis Ring Peer Statistics Output** — The following table describes multi-chassis ring peer output fields.

| Label          | Description                                                                          |
|----------------|--------------------------------------------------------------------------------------|
| Message        | Displays the message type.                                                           |
| Received       | Indicates the number of valid MC-Ring signalling messages received from the peer.    |
| Transmitted    | Indicates the number of valid MC-Ring signalling messages transmitted from the peer. |
| MCS ID Request | Displays the number of valid MCS ID requests were received from the peer.            |

| Label                | Description (Continued)                                                                               |
|----------------------|-------------------------------------------------------------------------------------------------------|
| MCS ID Response      | Displays the number of valid MCS ID responses were received from the peer.                            |
| Ring Exists Request  | Displays the number of valid 'ring exists' requests were received from the peer.                      |
| Ring Exists Response | Displays the number of valid ring exists' responses were received from the peer.                      |
| Keepalive            | Displays the number of valid MC-Ring control packets of type 'keepalive' were received from the peer. |

### Sample Output

```
*A:ALA-48>show>redundancy>multi-chassis# mc-ring peer 192.251.10.104 statistics
=====
MC Ring statistics for peer 192.251.10.104
=====
Message Received Transmitted

MCS ID Request 0 0
MCS ID Response 0 0
Ring Exists Request 0 0
Ring Exists Response 0 0
Keepalive 0 0

Total 0 0
=====
*A:ALA-48>show>redundancy>multi-chassis#
```

### Show MC-Ring Ring-Node Field Output

| Label      | Description                                                                                                                                                                                                                                                                                                                                                                                                                                                                                                                                                                                                                                                                         |
|------------|-------------------------------------------------------------------------------------------------------------------------------------------------------------------------------------------------------------------------------------------------------------------------------------------------------------------------------------------------------------------------------------------------------------------------------------------------------------------------------------------------------------------------------------------------------------------------------------------------------------------------------------------------------------------------------------|
| Oper State | <p>Displays the state of the connection verification (both local and remote).</p> <p><code>notProvisioned</code> – Connection verification is not provisioned.</p> <p><code>configErr</code> – Connection verification is provisioned but a configuration error prevents it from operating properly.</p> <p><code>notTested</code> – Connection verification is administratively disabled or is not possible in the current situation.</p> <p><code>testing</code> – Connection Verification is active, but no results are yet available.</p> <p><code>connected</code> – The ring node is reachable.</p> <p><code>disconnected</code> – Connection verification has timed out.</p> |

| Label  | Description (Continued)                                                                                               |
|--------|-----------------------------------------------------------------------------------------------------------------------|
| In Use | Displays “True” if the ring node is referenced on an e-pipe or as an inter-dest-id on a static host or dynamic lease. |

**Show MC-Ring Global-Statistics Field Output**

| Label                       | Description                                                                                                                |
|-----------------------------|----------------------------------------------------------------------------------------------------------------------------|
| Rx                          | Displays the number of MC-ring signalling packets were received by this system.                                            |
| Rx Too Short                | Displays the number of MC-ring signalling packets were received by this system that were too short.                        |
| Rx Wrong Authentication     | Displays the number of MC-ring signalling packets were received by this system with invalid authentication.                |
| Rx Invalid TLV              | Displays the number of MC-ring signalling packets were received by this system with invalid TLV.                           |
| Rx Incomplete               | Displays the number of MC-ring signalling packets were received by this system that were incomplete.                       |
| Rx Unknown Type             | Displays the number of MC-ring signalling packets were received by this system that were of unknown type.                  |
| Rx Unknown Peer             | Displays the number of MC-ring signalling packets were received by this system that were related to an unknown peer.       |
| Rx Unknown Ring             | Displays the number of MC-ring signalling packets were received by this system that were related to an unknown ring.       |
| Rx Unknown Ring Node        | Displays the number of MC-ring signalling packets were received by this system that were related to an unknown ring node.  |
| Tx                          | Displays the number of MC-ring signalling packets were transmitted by this system.                                         |
| Tx No Buffer                | Displays the number of MC-ring signalling packets could not be transmitted by this system due to a lack of packet buffers. |
| Tx Transmission Failed      | Displays the number of MC-ring signalling packets could not be transmitted by this system due to a transmission failure.   |
| Tx Unknown Destination      | Displays the number of MC-ring 'unknown destination' signalling packets were transmitted by this system.                   |
| Missed Configuration Events | Displays the number of missed configuration events on this system.                                                         |

| Label             | Description (Continued)                                  |
|-------------------|----------------------------------------------------------|
| Missed BFD Events | Displays the number of missed BFD events on this system. |

### Sample Output

```
*A:ALA-48>show>redundancy>multi-chassis# mc-ring global-statistics
=====
Global MC Ring statistics
=====
Rx : 0
Rx Too Short : 0
Rx Wrong Authentication : 0
Rx Invalid TLV : 0
Rx Incomplete : 0
Rx Unknown Type : 0
Rx Unknown Peer : 0
Rx Unknown Ring : 0
Rx Unknown Ring Node : 0
Tx : 36763
Tx No Buffer : 0
Tx Transmission Failed : 0
Tx Unknown Destination : 0
Missed Configuration Events : 0
Missed BFD Events : 0
=====
*A:ALA-48>show>redundancy>multi-chassis#
```

## switch-fabric

**Syntax** **switch-fabric**  
**switch-fabric high-bandwidth-multicast**

**Context** show>system

**Description** This command displays switch fabric information.

**Parameters** **high-bandwidth-multicast** — Displays MDA information about switch-fabric plane's high bandwidth multicast traffic tap allocation. **Sample Output**

```
A:SR-12# show system switch-fabric high-bandwidth-multicast
=====
Switch Fabric
=====
Slot/Mda Min Fwd Cap Max Fwd Cap Hi-Bw-Mcast Mcast Hi Mcast Low Group

3/1 100% 100% Yes #15# #1# 1
4/1 100% 100% No 3 4 0
4/2 100% 100% No 1 2 0
8/1 100% 100% Yes #15# #1# 2
A 100% 100% No 0 0 0
B 100% 100% No 0 0 0
=====
```

## Port Show Commands

A:SR-12#

## LAG Commands

### lag

**Syntax**    **lag** [*lag-id*] [**detail**] [**statistics**]  
**lag** [*lag-id*] **description**  
**lag** [*lag-id*] **port**  
**lag** *lag-id* **associations**  
**lag** *lag-id* **bfd**  
**lag** *lag-id* [**detail**] **eth-cfm** [**tunnel** *tunnel-id*]  
**lag** *lag-id* **associations per-link-hash interface**  
**lag** *lag-id* **associations link-map-profile** [*link-map-profile*] **interface**  
**lag** *lag-id* **lACP-partner**  
**lag** *lag-id* **detail lACP-partner**  
**lag** *lag-id* **link-map-profile** *link-map-profile*  
**lag** *lag-id* **associations per-link-hash sap**  
**lag** *lag-id* **associations link-map-profile** [*link-map-profile*] **sap**

**Context**    show

**Description**    This command displays Link Aggregation Group (LAG) information.  
 If no command line options are specified, a summary listing of all LAGs is displayed.

**Parameters**    *lag-id* — Displays only information on the specified LAG ID.

**Default**    Display information for all LAG IDs.

**Values**    1 — 200

**detail** — Displays detailed LAG information.

**Default**    Displays summary information.

**statistics** — Displays LAG statistics information.

**associations** — Displays a list of current router interfaces to which the LAG is assigned.

**link-map-profile** *link-map-profile* — Displays information about a particular LAG link map profile.

**eth-cfm** — Displays a list of Ethernet tunnels to which the LAG is assigned.

**per-link-hash** — Displays information about a SAP or interface associated with this LAG will send traffic over a single link of a LAG auto-rebalancing as links are added and removed from this LAG.

**lACP-partner** — Displays LACP partner information.

**link-map-profile** *link-map-profile* — Displays information about a specified LAG link map profile identifier.

## LAG Commands

**Output LAG Output** — The following table describes LAG output fields.

| Label          | Description                                                                                          |
|----------------|------------------------------------------------------------------------------------------------------|
| LAG ID         | The LAG or multi-link bundle ID that the port is assigned to.                                        |
| Adm            | Up — The LAG is administratively up.<br>Down — The LAG is administratively down.                     |
| Opr            | Up — The LAG is operationally up.<br>Down — The LAG is operationally down.                           |
| Port-Threshold | The number of operational links for the LAG at or below which the configured action will be invoked. |
| Up-Link-Count  | The number of ports that are physically present and have physical links present.                     |
| MC Act/Stdby   | Member port is selected as active or standby link.                                                   |

### Sample Output

```
A:ALA-48>config# show lag
=====
Lag Data
=====
Lag-id Adm Opr Port-Threshold Up-Link-Count MC Act/Stdby

1 up down 0 0 N/A
2 up up 0 1 active
3 up down 0 0 standby
4 up down 0 0 standby
10 up down 0 0 N/A

Total Lag-ids: 5 Single Chassis: 2 MC Act: 1 MC Stdby: 2
=====
A:ALA-48>config# show lag
```

```
A:sr7- show lag 10 port
=====
Lag Port States
LACP Status: e - Enabled, d - Disabled
=====
Lag-id Port-id Adm Act/Stdby Opr Primary Sub-group Forced Priority

10(e) 1/1/8 up active up yes 1 - 32768
 1/1/9 up standby down no 2 - 32768
=====
```

**Detailed LAG Output** — The following table describes detailed LAG output fields. The output is dependent on whether or not the LAG was configured as a multi-chassis LAG.

| Label                | Description                                                                                                                           |
|----------------------|---------------------------------------------------------------------------------------------------------------------------------------|
| LAG ID               | The LAG or multi-link trunk (MLT) that the port is assigned to.                                                                       |
| Adm                  | Up – The LAG is administratively up.<br>Down – The LAG is administratively down.                                                      |
| Port Threshold       | If the number of available links is equal or below this number, the threshold action is executed.                                     |
| Thres. Last Cleared  | The last time that keepalive stats were cleared.                                                                                      |
| Dynamic Cost         | The OSPF costing of a link aggregation group based on the available aggregated, operational bandwidth.                                |
| Configured Address   | The base chassis Ethernet MAC address.                                                                                                |
| Hardware Address     | The hardware address.                                                                                                                 |
| Hold-Time Down       | The timer, in tenths of seconds, which controls the delay between detecting that a LAG is down and reporting it to the higher levels. |
| LACP                 | Enabled – LACP is enabled.<br>Down – LACP is disabled.                                                                                |
| LACP Transmit Intvl  | LACP timeout signalled to peer.                                                                                                       |
| Selection Criteria   | Configured subgroup selection criteria.                                                                                               |
| Number of subgroups  | Total subgroups in LAG.                                                                                                               |
| System ID            | System ID used by actor in LACP messages.                                                                                             |
| Admin Key            | Configured LAG key.                                                                                                                   |
| Oper Key             | Key used by actor in LACP messages.                                                                                                   |
| System Priority      | System priority used by actor in LACP messages.                                                                                       |
| Prtr System ID       | System ID used by partner in LACP messages.                                                                                           |
| Prtr Oper Key        | Key used by partner in LACP messages.                                                                                                 |
| Prtr System Priority | System priority used by partner in LACP messages.                                                                                     |
| Mode                 | LAG in access or network mode.                                                                                                        |
| Opr                  | Up – The LAG is operationally up.<br>Down – The LAG is operationally down.                                                            |

| Label               | Description (Continued)                                                                 |
|---------------------|-----------------------------------------------------------------------------------------|
| Port Threshold      | Configured port threshold.                                                              |
| Thres. Exceeded Cnt | The number of times that the drop count was reached.                                    |
| Threshold Action    | Action to take when the number of available links is equal or below the port threshold. |
| Encap Type          | The encapsulation method used to distinguish customer traffic on a LAG.                 |
| Lag-IFIndex         | A box-wide unique number assigned to this interface.                                    |
| Adapt QoS           | Displays the configured QoS mode.                                                       |
| Port ID             | The specific slot/MDA/port ID.                                                          |
| (LACP) Mode         | LACP active or passive mode.                                                            |
| LACP xmit standby   | LACP transmits on standby links enabled / disabled.                                     |
| Slave-to-partner    | Configured enabled/disabled.                                                            |
| Port-id             | Displays the member port ID.                                                            |
| Adm                 | Displays the member port administrative state.                                          |
| Active/stdby        | Indicates that the member port is selected as the active or standby link.               |
| Opr                 | Indicates that the member port operational state.                                       |
| Primary             | Indicates that the member port is the primary port of the LAG.                          |
| Sub-group           | Displays the member subgroup where the member port belongs to.                          |
| Priority            | Displays the member port priority.                                                      |

### Sample Output

```
A:sr7- show lag 10 detail
=====
LAG Details
=====
Description : N/A

Details

Lag-id : 10 Mode : network
Adm : up Opr : up
Thres. Exceeded Cnt : 17 Port Threshold : 0
Thres. Last Cleared : 01/22/2000 19:41:38 Threshold Action : down
Dynamic Cost : false Encap Type : null
Configured Address : 0c:a4:02:20:69:4b Lag-IfIndex : 1342177290
```

```

Hardware Address : 0c:a4:02:20:69:4b
Hold-time Down : 0.0 sec
Port Type : standard
Per FP Ing Queuing : disabled
LACP : enabled
LACP Transmit Intvl : fast
Selection Criteria : highest-count
Number of sub-groups : 2
System Id : 0c:a4:02:20:68:01
Admin Key : 32770
Prtr System Id : 0c:a4:02:1f:88:01
Prtr Oper Key : 32771
Standby Signaling : lacp
Mode : active
LACP xmit stdby : enabled
Slave-to-partner : disabled
Forced : -
System Priority : 32768
Oper Key : 32770
Prtr System Priority : 32768

```

```

Port-id Adm Act/Stdby Opr Primary Sub-group Forced Prio

1/1/8 up active up yes 1 - 32768
1/1/9 up standby down yes 2 - 32768

```

```

Port-id Role Exp Def Dist Col Syn Aggr Timeout Activity

1/1/8 actor No No Yes Yes Yes Yes Yes Yes
1/1/8 partner No No Yes Yes Yes Yes Yes Yes
1/1/9 actor No No No No No Yes Yes Yes
1/1/9 partner No No No No No Yes Yes Yes

```

```

=====
*A:sr7-

```

**LAG Statistics Output** — The following table describes detailed LAG statistics output fields.

| Label               | Description                                                                                                                                                                                                                                                                                                                                                                                                                                                                                                                                                                                                  |
|---------------------|--------------------------------------------------------------------------------------------------------------------------------------------------------------------------------------------------------------------------------------------------------------------------------------------------------------------------------------------------------------------------------------------------------------------------------------------------------------------------------------------------------------------------------------------------------------------------------------------------------------|
| LAG ID              | The LAG or multi-link trunk (MLT) that the port is assigned to.                                                                                                                                                                                                                                                                                                                                                                                                                                                                                                                                              |
| Port ID             | The port ID configured or displayed in the <i>slot/mda/port</i> format.                                                                                                                                                                                                                                                                                                                                                                                                                                                                                                                                      |
| Input Bytes         | The number of incoming bytes for the LAG on a per-port basis.                                                                                                                                                                                                                                                                                                                                                                                                                                                                                                                                                |
| Input Packets       | The number of incoming packets for the LAG on a per-port basis.                                                                                                                                                                                                                                                                                                                                                                                                                                                                                                                                              |
| Output Bytes        | The number of outbound bytes for the LAG on a per-port basis.                                                                                                                                                                                                                                                                                                                                                                                                                                                                                                                                                |
| Output Packets      | The number of outbound packets for the LAG on a per-port basis.                                                                                                                                                                                                                                                                                                                                                                                                                                                                                                                                              |
| Input/Output Errors | For packet-oriented interfaces, the number of inbound packets that contained errors preventing them from being deliverable to a higher-layer protocol. For character-oriented or fixed-length interfaces, the number of inbound transmission units that contained errors preventing them from being deliverable to a higher-layer protocol.<br>For packet-oriented interfaces, the number of outbound packets that could not be transmitted because of errors. For character-oriented or fixed-length interfaces, the number of outbound transmission units that could not be transmitted because of errors. |
| Totals              | Displays the column totals for bytes, packets, and errors.                                                                                                                                                                                                                                                                                                                                                                                                                                                                                                                                                   |

**Sample Output**

```
ALA-1# show lag statistics
=====
LAG Statistics
=====
Description:
Lag-id Port-id Input Input Output Output Input Output
 Bytes Packets Bytes Packets Errors Errors

1 1/1/3 0 1006 0 2494 0 0
 1/1/4 0 435 0 401 0 0
 1/1/5 0 9968 0 9833 0 0

Totals 0 11409 0 12728 0 0
=====
ALA-1#
```

**LAG Associations Output** — The following table describes LAG associations output fields.

| Label      | Description                                                |
|------------|------------------------------------------------------------|
| Service ID | The service associated with the LAG.                       |
| Name       | The name of the IP interface.                              |
| Encap Val  | The Dot1q or QinQ values of the port for the IP interface. |

**Sample Output**

```
A:ALA-1# show lag 5 associations
=====
Interface Table
=====
Router/ServiceId Name Encap Val

Router: Base LAG2West 0

Interfaces
=====
A:ALA-1#
```

**LAG Details with MC-LAG Output** — The following example displays LAG output with MC LAG:

```
*A:pc5# show lag 2 detail
=====
LAG Details
=====
Description:

Details

Lag-id : 2 Mode : access
Adm : up Opr : up
```

## Interface Configuration

```

Thres. Exceeded Cnt : 2
Thres. Last Cleared : 04/11/2007 21:50:55
Dynamic Cost : false
Configured Address : 8e:8b:ff:00:01:42
1342177282
Hardware Address : 8e:8b:ff:00:01:42
distribute
Hold-time Down : 0.0 sec
LACP : enabled
LACP Transmit Intvl : fast
Selection Criteria : highest-count
Number of sub-groups: 2
System Id : 8e:8b:ff:00:00:00
Admin Key : 32768
Prtr System Id : 8e:89:ff:00:00:00
Prtr Oper Key : 32768

Port Threshold : 0
Threshold Action : down
Encap Type : dot1q
Lag-IfIndex :
Adapt Qos :
Mode : active
LACP xmit stdby : enabled
Slave-to-partner : disabled
Forced : -
System Priority : 32768
Oper Key : 32768
Prtr System Priority : 32768

MC Peer Address : 10.10.10.101
MC System Id : 01:01:01:01:01:01
MC Admin Key : 1
MC Lacp ID in use : false
MC Selection Logic : waiting for peer info

MC Peer Lag-id : 2
MC System Priority : 2
MC Active/Standby : active
MC extended timeout : false
MC Config Mismatch : no mismatch

Port-id Adm Act/Stdby Opr Primary Sub-group Forced
Prio

1/1/1 up active up yes 7 - 99
1/1/2 up standby down no 8 - 100

Port-id Role Exp Def Dist Col Syn Aggr Timeout
Activity

1/1/1 actor No No Yes Yes Yes Yes Yes Yes
1/1/1 partner No No Yes Yes Yes Yes Yes Yes Yes
1/1/2 actor No No No No No Yes Yes Yes Yes
1/1/2 partner No No No No Yes Yes Yes Yes Yes Yes
=====
*A:pc5#

```

**LAG Details without MC-LAG Output** — The following example displays LAG output without MC LAG:

```

*A:pc5# show lag 2 detail
=====
LAG Details
=====
Description:

Details

Lag-id : 2
Adm : up
Thres. Exceeded Cnt : 4
Thres. Last Cleared : 04/11/2007 02:03:49
Dynamic Cost : false
Configured Address : 8e:8b:ff:00:01:42
1342177282
Hardware Address : 8e:8b:ff:00:01:42
distribute

Mode : access
Opr : up
Port Threshold : 0
Threshold Action : down
Encap Type : dot1q
Lag-IfIndex :
Adapt Qos :

```

## LAG Commands

```

Hold-time Down : 0.0 sec
LACP : enabled
Mode : active
LACP Transmit Intvl : fast
LACP xmit stdby : enabled
Selection Criteria : highest-count
Slave-to-partner : disabled
Number of sub-groups: 2
Forced : -
System Id : 8e:8b:ff:00:00:00
System Priority : 32768
Admin Key : 32768
Oper Key : 32768
Prtr System Id : 8e:89:ff:00:00:00
Prtr System Priority : 32768
Prtr Oper Key : 32768

```

```

Port-id Adm Act/Stdby Opr Primary Sub-group Forced
Prio

1/1/1 up active up yes 7 - 99
1/1/2 up standby down 8 - 100

```

```

Port-id Role Exp Def Dist Col Syn Aggr Timeout
Activity

1/1/1 actor No No Yes Yes Yes Yes Yes Yes
1/1/1 partner No No Yes Yes Yes Yes Yes Yes
1/1/2 actor No No No No No Yes Yes Yes
1/1/2 partner No No No No Yes Yes Yes Yes

```

```

*A:pc5#

```

**LACP Partner Output** — The following output shows LAG LACP partner information.

```
A:ALU-Dut1# show lag 3 lacp-partner
=====
LAG Partner information
=====
Partner system ID : ea:3e:ff:00:00:00
Partner system priority : 32768
Partner operational key : 2
=====
LAG 3 Ports Partner operational information
=====
Port Actor Port Prio Key
 port

1/1/52 33908 33909 5 2
1/1/54 33910 33911 5 2
1/1/56 33912 33913 7 2
=====
LAG 3 Ports Partner operational state information
=====
Port Exp Def Dist Col Syn Aggr Time Act
 out

1/1/52 No No Yes Yes Yes Yes Yes Yes
1/1/54 No No Yes Yes Yes Yes Yes Yes
1/1/56 No No No No No Yes Yes Yes
=====
A:ALU-Dut1#

A:Dut-A# show lag 10 lacp-neighbors
=====
LAG Neighbor information
=====
Partner system ID : de:41:ff:00:00:00
Partner system priority : 32768
Partner operational key : 32768
=====
LAG port 1/1/6 partner information
=====
Actor port : 33862
Partner admin system prio : 32768
Partner oper system prio : 32768
Partner admin system ID : 00:00:00:00:00:00
Partner oper system ID : de:41:ff:00:00:00
Partner admin key : 0
Partner oper key : 32768
Partner admin port : (Not Specified)
Partner oper port : 33863
Partner admin port prio : 32768
Partner oper port prio : 32768
Partner admin state : (Not Specified)
Partner oper state : lacp-timeout aggregation synchronization
 collecting distributing
```

## LAG Commands

```
=====
A:Dut-A#
*A:bksim4001>config>lag# selection-criteria highest-weight subgroup-hold-time lshow lag 1
detail
 ght subgroup-hold-time 10

=====
LAG Details
=====
Description : To Sim4002

Details

Lag-id : 1
Adm : down
Thres. Exceeded Cnt : 0
Thres. Last Cleared : 01/21/2014 09:00:48
Dynamic Cost : false
Configured Address : 36:95:ff:00:01:41
Hardware Address : 36:95:ff:00:01:41
Hold-time Down : 0.0 sec
Per-Link-Hash : disabled
Include-Egr-Hash-Cfg : enabled
Per FP Ing Queuing : disabled
Per FP SAP Instance : disabled
LACP : enabled
LACP Transmit Intvl : fast
Selection Criteria : highest-weight
Subgrp hold time : 20.0 sec
Subgrp selected : 1
Subgrp count : 2
System Id : 36:95:ff:00:00:00
Admin Key : 32768
Prtr System Id :
Prtr Oper Key : 0
Standby Signaling : lacp
Port weight (gbps) : (Not Specified)
Weight Threshold : 0

Mode : access
Opr : down
Port Threshold : 0
Threshold Action : down
Encap Type : null
Lag-IfIndex : 1342177281
Adapt Qos (access) : distribute
Port Type : standard

Per FP Egr Queuing : disabled
Mode : passive
LACP xmit stdby : enabled
Slave-to-partner : disabled
Remaining time : 2.6 sec
Subgrp candidate : 2
Forced : -
System Priority : 32768
Oper Key : 32768
Prtr System Priority : 0
Threshold Action : down
```

---

## Monitor Commands

### card

**Syntax** `card slot-number fp fp-number ingress {access|network} queue-group queue-group-name instance instance-id [absolute] [interval seconds] [repeat repeat] policer policer-id`

**Context** monitor

**Description** This command monitors card parameters.

### port

**Syntax** `port port-id [port-id...(up to 5 max)] [interval seconds] [repeat repeat] [absolute | rate] [multiclass]`

**Context** monitor

**Description** This command enables port traffic monitoring. The specified port(s) statistical information displays at the configured interval until the configured count is reached.

The first screen displays the current statistics related to the specified port(s). The subsequent statistical information listed for each interval is displayed as a delta to the previous display.

When the keyword **rate** is specified, the "rate per second" for each statistic is displayed instead of the delta.

Monitor commands are similar to **show** commands but only statistical information displays. Monitor commands display the selected statistics according to the configured number of times at the interval specified.

**Parameters** `port port-id` — Specify up to 5 port IDs.

**Syntax:** `port-id slot/mda/port[channel]`  
**interval seconds** — Configures the interval for each display in seconds.

**Default** 10 seconds

**Values** 3 — 60

**repeat repeat** — Configures how many times the command is repeated.

**Default** 10

**Values** 1 — 999

**absolute** — When the **absolute** keyword is specified, the raw statistics are displayed, without processing. No calculations are performed on the delta or rate statistics.

**rate** — When the **rate** keyword is specified, the rate-per-second for each statistic is displayed instead of the delta.

## Monitor Commands

### Sample Output

```
A:ALA-12>monitor# port 2/1/4 interval 3 repeat 3 absolute
=====
Monitor statistics for Port 2/1/4
=====

```

|                                     | Input | Output |
|-------------------------------------|-------|--------|
| -----                               |       |        |
| At time t = 0 sec (Base Statistics) |       |        |
| -----                               |       |        |
| Octets                              | 0     | 0      |
| Packets                             | 39    | 175    |
| Errors                              | 0     | 0      |
| -----                               |       |        |
| At time t = 3 sec (Mode: Absolute)  |       |        |
| -----                               |       |        |
| Octets                              | 0     | 0      |
| Packets                             | 39    | 175    |
| Errors                              | 0     | 0      |
| -----                               |       |        |
| At time t = 6 sec (Mode: Absolute)  |       |        |
| -----                               |       |        |
| Octets                              | 0     | 0      |
| Packets                             | 39    | 175    |
| Errors                              | 0     | 0      |
| -----                               |       |        |
| At time t = 9 sec (Mode: Absolute)  |       |        |
| -----                               |       |        |
| Octets                              | 0     | 0      |
| Packets                             | 39    | 175    |
| Errors                              | 0     | 0      |
| =====                               |       |        |

```
A:ALA-12>monitor#
```

```
A:ALA-12>monitor# port 2/1/4 interval 3 repeat 3 rate
=====
Monitor statistics for Port 2/1/4
=====

```

|                                     | Input | Output |
|-------------------------------------|-------|--------|
| -----                               |       |        |
| At time t = 0 sec (Base Statistics) |       |        |
| -----                               |       |        |
| Octets                              | 0     | 0      |
| Packets                             | 39    | 175    |
| Errors                              | 0     | 0      |
| -----                               |       |        |
| At time t = 3 sec (Mode: Rate)      |       |        |
| -----                               |       |        |
| Octets                              | 0     | 0      |
| Packets                             | 0     | 0      |
| Errors                              | 0     | 0      |
| -----                               |       |        |
| At time t = 6 sec (Mode: Rate)      |       |        |
| -----                               |       |        |
| Octets                              | 0     | 0      |
| Packets                             | 0     | 0      |
| Errors                              | 0     | 0      |
| -----                               |       |        |
| At time t = 9 sec (Mode: Rate)      |       |        |
| -----                               |       |        |

```

Octets 0 0
Packets 0 0
Errors 0 0
=====
A:ALA-12>monitor#

=====
*A:Cpm-A> monitor port bundle-fr-1/1.1
=====
Monitor statistics for Port bundle-fr-1/1.1
=====
 Input Output

At time t = 0 sec (Base Statistics)

Octets 0 0
Packets 0 0
Errors 0 0

```

## queue-group

**Syntax** **queue-group** *queue-group-name* **egress** *access egress-queue egress-queue-id* [**interval** *seconds*] [**repeat** *repeat*] [**absolute**|**rate**]

**Context** monitor

**Description** This command enables queue-group monitoring for the specified parameters.

## queue-group

**Syntax** **queue-group** *queue-group-name* **ingress** *access ingress-queue ingress-queue-id* [**interval** *seconds*] [**repeat** *repeat*] [**absolute** | **rate**]

**Context** monitor

**Description** This command enables queue-group monitoring for the specified parameters.

## queue-group

**Syntax** **queue-group** *queue-group-name* **egress** *network instance instance-id* [**policer** *policer-id*] [**egress-queue** *egress-queue-id*] [**interval** *seconds*] [**repeat** *repeat*] [**absolute** | **rate**]

**Context** monitor

**Description** This command enables queue-group monitoring for the specified parameters.

port

**Syntax** `atm [interval seconds] [repeat repeat] [absolute | rate]`

**Context** monitor>port

**Description** This command enables ATM port traffic monitoring.

**Parameters** `interval seconds` — Configures the interval for each display in seconds.

**Default** 5 seconds

**Values** 3 — 60

`repeat repeat` — Configures how many times the command is repeated.

**Default** 10

**Values** 1 — 999

**absolute** — When the **absolute** keyword is specified, the raw statistics are displayed, without processing. No calculations are performed on the delta or rate statistics.

**rate** — When the **rate** keyword is specified, the rate-per-second for each statistic is displayed instead of the delta.

**Sample Output**

```
A:ALA-49# monitor port 9/1/1 atm interval 3 repeat 2 absolute
=====
Monitor ATM statistics for Port 9/1/1
=====
 Input Output

At time t = 0 sec (Base Statistics)

Octets 0 0
Cells 0 0
Unknown VPI/VCI Cells 0

At time t = 3 sec (Mode: Absolute)

Octets 0 0
Cells 0 0
Unknown VPI/VCI Cells 0

At time t = 6 sec (Mode: Absolute)

Octets 0 0
Cells 0 0
Unknown VPI/VCI Cells 0
=====
A:ALA-49#
```

---

## Clear Commands

### card

**Syntax** `card slot-number`  
`card slot-number`  
`card slot-number fp [1..2] ingress mode {access|network} queue-group group-name instance instance statistics`  
`card slot-number`

**Context** clear

**Description** This command re-initializes the card in the specified slot.

**Parameters** *slot-number* — Clears information for the specified card slot.

**Values**

1 - 10

### lag

**Syntax** `lag lag-id statistics`

**Context** clear

**Description** This command clears statistics for the specified LAG ID.

**Parameters** *lag-id* — The LAG ID to clear statistics.

**Values** 1 — 200

**statistics** — Specifies to clear statistics for the specified LAG ID.

### mda

**Syntax** `mda mda-id [statistics]`

**Context** clear

**Description** This command reinitializes the specified MDA in a particular slot.

**Parameters** *mda-id* — Clears the specified slot and MDA.

**statistics** — Clears statistics for the specified MDA.

## Monitor Commands

### port

**Syntax** **port** <port-id> **phys-state-change-count**  
**port** *port-id* **queue-group** *queue-group-name* [**access** | **network**] {**ingress** | **egress**}  
[**access**|**network**] [{**statistics**|**associations**}]  
**port** *port-id* **statistics**

**Context** clear

**Description** This command clears port statistics for the specified port(s).

**Parameters** *port-id* — The port identifier.

*port-id* slot[/mda[/port]] or slot/mda/port[.channel]

**statistics** — Specifies that port statistics will be cleared.

*slot* — The slot number.

**Values** 1 - 10

*mda* — The MDA number.

**Default** All MDAs.

**Values** 1, 2

7750 SR-c12: 1, 3, 5, 7, 9, 117750 SR-c12: 1-12 **pvc** — Clears PVC statistics.

**port-connection** — Clears port-connection statistics.

**phys-state-change-count** — Clears the counter that tracks physical port state transitions for ethernet ports ("Phys State Chng Cnt" in "show port" output, or tmnxPortPhysStateChangeCount in the TIMETRA-PORT-MIB)

**queue-group** *queue-group-name* — Clears the specified port queue group name. It uniquely identifies a port ingress queue group in the managed system.

**ingress** — Clears ingress queue group information.

**egress** — Clears egress queue group information

### queue-group

**Syntax** **queue-group** *queue-group-name* **egress** *access* **egress-queue** *egress-queue-id* [**interval** *seconds*] [**repeat** *repeat*] [**absolute**|**rate**]

**Context** clear

**Description** This command clears queue-group monitoring for the specified parameters.

## queue-group

**Syntax** **queue-group** *queue-group-name* **ingress** *access* **ingress-queue** *ingress-queue-id* [**interval** *seconds*] [**repeat** *repeat*] [**absolute** | **rate**]

Context clear

**Description** This command clears queue-group monitoring for the specified parameters.

## queue-group

**Syntax** **queue-group** *queue-group-name* **egress** *network* **instance** *instance-id* [**policer** *policer-id*] [**egress-queue** *egress-queue-id*] [**interval** *seconds*] [**repeat** *repeat*] [**absolute** | **rate**]

Context clear

**Description** This command clears queue-group monitoring for the specified parameters.

---

## Tools Commands

### eth-tunnel

**Syntax** `eth-tunnel tunnel-index [clear]`

**Context** `tools>dump`

**Description** This command displays Ethernet tunnel information.

#### Sample Output

```
*A:PE-E# tools dump eth-tunnel 1

TunnelId 1 (Up/Up), Port eth-tunnel-1 (Up/Up): type g8031-1to1
NumMems 2/2, Up/Dn 0/0, active 0x1, present 0x3 baseMemPort 1/1/2
 memId 1 (P), port 1/1/2 (Up), tag 1.0(Up) status (Up/Up)
 ccCnt-sf/ok 1/1 idx 0 tunId 1
 memId 2 (S), port 2/1/2 (Up), tag 1.0(Up) status (Up/Up)
 ccCnt-sf/ok 0/0 idx 1 tunId 1

TunId = 1, state = Running, Active = Work, Now = 000 00:16:48.140
revert = 1, ReqState = NR-NULL, Pdu(Tx/Rx): 0x0f0000/0x0f0000
Defects =
Running Timers = PduReTx
 Work MemId = 1 (1/1/2:1.0), state = Ok, cc = 000 00:16:23.510U
 ActiveCnt = 4, ActiveSeconds = 791
 Protect MemId = 2 (2/1/2:1.0), state = Ok, cc = 000 00:09:47.560U
 ActiveCnt = 3, ActiveSeconds = 308
DbgCnts: swoEv = 2, wMemSts = 2, pMemSts = 0
 rxPdu (valid/Invalid) = 4/0, wSfClr = 1, pSfClr = 0, wtrExp = 1
 cm = 0, cmClr = 0, pm = 0, pmClr = 0, nr = 0, nrClr = 0
Seq Event TxPdu RxPdu Dir Act Time
=== ===== ===== ===== ===== ===== =====
000 wMemSts 0xbf0101 wSF 0x0f0000 NR Tx--> Prot 000 00:16:12.450
001 RxPdu 0xbf0101 wSF 0x0f0101 NR Rx<-- Prot 000 00:16:12.450
002 RxPdu 0xbf0101 wSF 0xbf0101 wSF Rx<-- Prot 000 00:16:12.480
003 RxPdu 0xbf0101 wSF 0x0f0101 NR Rx<-- Prot 000 00:16:24.890
004 wSfClr 0x5f0101 WTR 0x0f0101 NR Tx--> Prot 000 00:16:25.030
005 WTR 0x0f0000 NR 0x0f0101 NR Tx--> Work 000 00:16:26.630
006 RxPdu 0x0f0000 NR 0x0f0000 NR Rx<-- Work 000 00:16:26.630
*A:PE-E#
```

### lag

**Syntax** `lag lag-id lag-id`

**Context** tools>dump

**Description** This command dumps LAG information.

**Parameters** *lag-id* — Specifies the LAG ID.

**Values** 1..200

## map-to-phy-port

**Syntax** **map-to-phy-port** {**ccag** *ccag-id* | **lag** *lag-id* | **eth-tunnel** *tunnel-index*} {**isid** *isid* [**end-isid** *isid*] | **service** *service-id* | *svc-name* [**end-service** *service-id* | *svc-name*]} [**summary**]

**Context** tools>dump

**Description** This command provides the ability to respond to a query to provide the link in a LAG/Ethernet tunnel (loadsharing protection mode)/CCAG that is currently assigned to a given service-id or ISID.

**Parameters** *lag-id* — Specifies the LAG ID.

**Values** 1..200

*isid* — Specifies the ISID.

**Values** 0..16777215

*service-id* — Specifies the service ID.

**Values** 1..2147483648, 64 char max

*tunnel-index* — Specifies the tunnel index.

**Values** 1..1024

*ccag-id* — Specifies the CCAG ID.

**Values** 1..8

## redundancy

**Syntax** **redundancy**

**Context** tools>dump

**Description** This command enables the context to dump redundancy parameters.

## multi-chassis

**Syntax** **multi-chassis**

**Context** tools>dump>redundancy

## Monitor Commands

**Description** This command enables the context to dump multi-chassis parameters.

### mc-ring

**Syntax** **mc-ring**

**Context** tools>dump>redundancy>multi-chassis

**Description** This command dumps multi-chassis ring data.

### sync-database

**Syntax** **sync-database** [**peer** *ip-address*] [**port** *port-id* | *lag-id*] [**sync-tag** *sync-tag*] [**application** {**dhcps** | **igmp** | **igmp-snooping** | **srrp** | **sub-mgmt** | **mld-snooping** | **mc-ring**}] [**detail**] [**type** {**alarm-deleted** | **local-deleted**}]

**Context** tools>dump>redundancy>multi-chassis

**Description** This command dumps multi-chassis sync database information.

**Parameters** **peer** *ip-address* — Dumps the specified address of the multi-chassis peer.

**port** *port-id* — Dumps the specified port ID of the multi-chassis peer.

**port** *lag-id* — Dumps the specified Link Aggregation Group (LAG) on this system.

**sync-tag** *sync-tag* — Dumps the synchronization tag used while synchronizing this port with the multi-chassis peer.

**application** — Dumps the specified application information that was synchronized with the multi-chassis peer.

**Values** dhcps, igmp, igmp-snooping, mc-ring, srrp, sub-mgmt, mld-snooping, all

**detail** — Displays detailed information.

*alarm-deleted*/*local-deleted* — Filters by entry type.

### Sample Output

```
A:Dut-C# tools dump redundancy multi-chassis sync-database application
```

```
<ip-address> : a.b.c.d
<port-id|lag-id> : slot/mda/port or lag-<lag-id>
<sync-tag> : [32 chars max]
<application> : dhcp-server - local dhcp server
 igmp - internet group management protocol
 igmp-snooping - igmp-snooping
 mc-ring - multi-chassis ring
 mld - multicast listener discovery
 mld-snooping - multicast listener discovery-snooping
 srrp - simple router redundancy protocol
 sub-host-trk - subscriber host tracking
```

```

sub-mgmt-ipoe - subscriber management for IPoE
sub-mgmt-pppoe - subscriber management for PPPoE
mc-ipsec - multi-chassis IPsec
<detail> : keyword - displays detailed information
<type> : alarm-deleted|local-deleted|global-deleted|
 omcr-standby|omcr-alarmed

```

*bundle-num* — Specifies the bundle number.

**Values**     1 — 256

## set-fabric-speed

**Syntax**     **set-fabric-speed** *speed*

**Context**    tools>perform

### Description

---

## Debug Commands

### lag

**Syntax**    **lag** [**lag-id** *lag-id* [**port** *port-id*]] [**all**]  
              **lag** [**lag-id** *lag-id* [**port** *port-id*]] [**sm**] [**pkt**] [**cfg**] [**red**] [**iom-upd**] [**port-state**] [**timers**] [**sel-logic**]  
              [**mc**] [**mc-pkt**]  
              **no lag** [**lag-id** *lag-id*]

**Context**    debug

**Description**    This command enables debugging for LAG.

**Parameters**    *lag-id* — Specifies the link aggregation group ID.

*port-id* — Specifies the physical port ID.

**Syntax:**    *slot/mda/port[.channel]*

**sm** — Specifies to display trace LACP state machine.

**pkt** — Specifies to display trace LACP packets.

**cfg** — Specifies to display trace LAG configuration.

**red** — Specifies to display trace LAG high availability.

**iom-upd** — Specifies to display trace LAG IOM updates.

**port-state** — Specifies to display trace LAG port state transitions.

**timers** — Specifies to display trace LAG timers.

**sel-logic** — Specifies to display trace LACP selection logic.

**mc** — Specifies to display multi-chassis parameters.

**mc-packet** — Specifies to display the MC-LAG control packets with valid authentication were received on this system.

# Standards and Protocol Support

---

## Ethernet Standards

IEEE 802.1ab-REV/D3 Station and Media Access Control Connectivity Discovery  
IEEE 802.1d Bridging  
IEEE 802.1p/Q VLAN Tagging  
IEEE 802.1s Multiple Spanning Tree  
IEEE 802.1w Rapid Spanning Tree Protocol  
IEEE 802.1x Port Based Network Access Control  
IEEE 802.1ad Provider Bridges  
IEEE 802.1ah Provider Backbone Bridges  
IEEE 802.1ag Service Layer OAM  
IEEE 802.3ah Ethernet in the First Mile  
IEEE 802.1ak Multiple MAC Registration Protocol  
IEEE 802.3 10BaseT  
IEEE 802.3ad Link Aggregation  
IEEE 802.3ae 10Gbps Ethernet  
IEEE 802.3ah Ethernet OAM  
IEEE 802.3u 100BaseTX  
IEEE 802.3x Flow Control  
IEEE 802.3z 1000BaseSX/LX  
ITU-T Y.1731 OAM functions and mechanisms for Ethernet based networks  
ITU-T G.8031 Ethernet linear protection switching  
ITU-T G.8032 Ethernet Ring Protection Switching (version 2)

## OSPF

RFC 1765 OSPF Database Overflow  
RFC 2328 OSPF Version 2  
RFC 2370 Opaque LSA Support  
RFC 2740 OSPF for IPv6 (OSPFv3)  
draft-ietf-ospf-ospfv3-update-14.txt  
RFC 3101 OSPF NSSA Option  
RFC 3137 OSPF Stub Router Advertisement  
RFC 3623 Graceful OSPF Restart – GR helper

RFC 3630 Traffic Engineering (TE) Extensions to OSPF Version 2  
RFC 4203 OSPF Extensions in Support of Generalized Multi-Protocol Label Switching (GMPLS) - (support of Link Local/Remote Identifiers and SRLG sub-TLVs)  
RFC 5185 OSPF Multi-Area Adjacency  
RFC5243 OSPF Database Summary List Optimization

## BGP

RFC 1397 BGP Default Route Advertisement  
RFC 1772 Application of BGP in the Internet  
RFC 1965 Confederations for BGP  
RFC 1997 BGP Communities Attribute  
RFC 2385 Protection of BGP Sessions via MD5  
RFC 2439 BGP Route Flap Dampening  
RFC 2558 Multiprotocol Extensions for BGP-4  
RFC 2918 Route Refresh Capability for BGP-4  
RFC 3107 Carrying Label Information in BGP-4  
RFC 3392 Capabilities Advertisement with BGP4  
RFC 4271 BGP-4 (previously RFC 1771)  
RFC 4360 BGP Extended Communities Attribute  
RFC 4364 BGP/MPLS IP Virtual Private Networks (VPNs)(previously RFC 2547bis BGP/MPLS VPNS)  
RFC 4456 BGP Route Reflection: Alternative to Full-mesh IBGP (previously RFC 1966 & 2796)  
RFC 4486 Subcodes for BGP Cease Notification Message  
RFC 4577 OSPF as the Provider/Customer Edge Protocol for BGP/MPLS IP Virtual Private Networks (VPNs)  
RFC 4659 BGP-MPLS IP Virtual Private Network (VPN) Extension for IPv6 VPN

RFC 4684 Constrained Route Distribution for Border Gateway Protocol/MultiProtocol Label Switching (BGP/MPLS) Internet Protocol (IP) Virtual Private Networks (VPNs)  
RFC 4724 Graceful Restart Mechanism for BGP – GR helper  
RFC 4760 Multi-protocol Extensions for BGP  
RFC 4798 Connecting IPv6 Islands over IPv4 MPLS Using IPv6 Provider Edge Routers (6PE)  
RFC 4893 BGP Support for Four-octet AS Number Space  
RFC 5004 Avoid BGP Best Path Transitions from One External to Another  
RFC 5065 Confederations for BGP (obsoletes 3065)  
RFC 5291 Outbound Route Filtering Capability for BGP-4  
RFC 5575 Dissemination of Flow Specification Rules  
RFC 5668 4-Octet AS Specific BGP Extended Community  
draft-ietf-idr-add-paths  
draft-ietf-idr-best-external

## IS-IS

ISO/IEC 10589:2002, Second Edition Intermediate System to Intermediate System Intra-Domain Routeing Information Exchange Protocol  
RFC 1195 Use of OSI IS-IS for Routing in TCP/IP and Dual Environments  
RFC 2973 IS-IS Mesh Groups  
RFC 3359 Reserved Type, Length and Value (TLV) Codepoints in Intermediate System to Intermediate System  
RFC 3719 Recommendations for Interoperable Networks using Intermediate System to Intermediate System (IS-IS)  
RFC 3787 Recommendations for Interoperable IP Networks using

## Standards and Protocols

Intermediate System to Intermediate System (IS-IS)  
RFC 5120 M-ISIS: Multi Topology (MT) Routing in IS-IS (Partial)  
RFC 5301 Dynamic Hostname Exchange Mechanism for IS-IS  
RFC 5302 Domain-wide Prefix Distribution with Two-Level IS-IS  
RFC 5303 Three-Way Handshake for IS-IS Point-to-Point Adjacencies  
RFC 5304 IS-IS Cryptographic Authentication  
RFC 5305 IS-IS Extensions for Traffic Engineering TE  
RFC 5306 Restart Signaling for IS-IS  
RFC 5307 IS-IS Extensions in Support of Generalized Multi-Protocol Label Switching (GMPLS)  
RFC 5309 Point-to-Point Operation over LAN in Link State Routing Protocols  
RFC 6329 IS-IS Extensions Supporting IEEE 802.1aq Shortest Path Bridging (Partial)  
draft-ietf-isis-mi IS-IS Multi-Instance

### IPSec

RFC 2401 Security Architecture for the Internet Protocol  
RFC 2406 IP Encapsulating Security Payload (ESP)  
RFC 2409 The Internet Key Exchange (IKE)  
RFC 2560 X.509 Internet Public Key Infrastructure  
    Online Certificate Status Protocol - OCSP  
RFC 3706 IKE Dead Peer Detection  
RFC 3947 Negotiation of NAT-Traversal in the IKE  
RFC 3948 UDP Encapsulation of IPsec ESP Packets  
RFC 4210 Internet X.509 Public Key Infrastructure  
    Certificate Management Protocol (CMP)  
RFC 4211 Internet X.509 Public Key Infrastructure  
    Certificate Request Message Format (CRMF)  
RFC 5996 Internet Key Exchange Protocol Version 2 (IKEv2)

RFC 5998 An Extension for EAP-Only Authentication in IKEv2  
draft-ietf-ipsec-isakmp-xauth-06.txt – Extended Authentication within ISAKMP/Oakley (XAUTH)  
draft-ietf-ipsec-isakmp-modecfg-05.txt – The ISAKMP Configuration Method

### IPv6

RFC 1981 Path MTU Discovery for IPv6  
RFC 2375 IPv6 Multicast Address Assignments  
RFC 2460 Internet Protocol, Version 6 (IPv6) Specification  
RFC 2461 Neighbor Discovery for IPv6  
RFC 2462 IPv6 Stateless Address Auto configuration  
RFC 2463 Internet Control Message Protocol (ICMPv6) for the Internet Protocol Version 6 Specification  
RFC 2464 Transmission of IPv6 Packets over Ethernet Networks  
RFC 2529 Transmission of IPv6 over IPv4 Domains without Explicit Tunnels  
RFC 2545 Use of BGP-4 Multiprotocol Extension for IPv6 Inter-Domain Routing  
RFC 2710 Multicast Listener Discovery (MLD) for IPv6  
RFC 2740 OSPF for IPv6  
RFC 3306 Unicast-Prefix-based IPv6 Multicast Addresses  
RFC 3315 Dynamic Host Configuration Protocol for IPv6  
RFC 3587 IPv6 Global Unicast Address Format  
RFC3590 Source Address Selection for the Multicast Listener Discovery (MLD) Protocol  
RFC 3810 Multicast Listener Discovery Version 2 (MLDv2) for IPv6  
RFC 4007 IPv6 Scoped Address Architecture  
RFC 4193 Unique Local IPv6 Unicast Addresses  
RFC 4291 IPv6 Addressing Architecture  
RFC 4552 Authentication/Confidentiality for OSPFv3  
RFC 4659 BGP-MPLS IP Virtual Private Network (VPN) Extension for IPv6 VPN

RFC 5072 IP Version 6 over PPP  
RFC 5095 Deprecation of Type 0 Routing Headers in IPv6  
RFC 5308 Routing IPv6 with IS-IS

### Multicast

RFC 1112 Host Extensions for IP Multicasting (Snooping)  
RFC 2236 Internet Group Management Protocol, (Snooping)  
RFC 3376 Internet Group Management Protocol, Version 3 (Snooping)  
RFC 2362 Protocol Independent Multicast-Sparse Mode (PIMSM)  
RFC 3618 Multicast Source Discovery Protocol (MSDP)  
RFC 3446 Anycast Rendezvous Point (RP) mechanism using Protocol Independent Multicast (PIM) and Multicast Source Discovery Protocol (MSDP)  
RFC 4601 Protocol Independent Multicast - Sparse Mode (PIM-SM): Protocol Specification (Revised)  
RFC 4604 Using IGMPv3 and MLDv2 for Source-Specific Multicast  
RFC 4607 Source-Specific Multicast for IP  
RFC 4608 Source-Specific Protocol Independent Multicast in 232/8  
RFC 4610 Anycast-RP Using Protocol Independent Multicast (PIM)  
draft-ietf-pim-sm-bsr-06.txt  
draft-rosen-vpn-mcast-15.txt Multicast in MPLS/BGP IP VPNs  
draft-ietf-mboned-msdp-mib-01.txt  
draft-ietf-l3vpn-2547bis-mcast-07: Multicast in MPLS/BGP IP VPNs  
draft-ietf-l3vpn-2547bis-mcast-bgp-05: BGP Encodings and Procedures for Multicast in MPLS/BGP IP VPNs  
RFC 3956: Embedding the Rendezvous Point (RP) Address in an IPv6 Multicast Address

### MPLS

RFC 2430 A Provider Architecture DiffServ & TE  
RFC 2474 Definition of the DS Field the IPv4 and IPv6 Headers (Rev)

RFC 2597 Assured Forwarding PHB Group (rev3260)  
 RFC 2598 An Expedited Forwarding PHB  
 RFC 3031 MPLS Architecture  
 RFC 3032 MPLS Label Stack Encoding  
 RFC 3443 Time To Live (TTL) Processing in Multi-Protocol Label Switching (MPLS) Networks  
 RFC 4182 Removing a Restriction on the use of MPLS Explicit NULL  
 RFC 3140 Per-Hop Behavior Identification Codes  
 RFC 5332 MPLS Multicast Encapsulations

#### **MPLS — LDP**

RFC 3037 LDP Applicability  
 RFC 3478 Graceful Restart Mechanism for LDP – GR helper  
 RFC 5036 LDP Specification  
 RFC 5283 LDP extension for Inter-Area LSP  
 RFC 5443 LDP IGP Synchronization  
 RFC 6388 LDP Extensions for Point-to-Multipoint and Multipoint-to-Multipoint LSP  
 RFC 6826 Multipoint LDP in-band signaling for Point-to-Multipoint and Multipoint-to-Multipoint Label Switched Paths  
 draft-pdutta-mpls-ldp-hello-reduce-04.txt, Targeted LDP Hello Reduction

#### **MPLS/RSVP-TE**

RFC 2702 Requirements for Traffic Engineering over MPLS  
 RFC2747 RSVP Cryptographic Authentication  
 RFC 2961 RSVP Refresh Overhead Reduction Extensions  
 RFC3097 RSVP Cryptographic Authentication - Updated Message Type Value  
 RFC 3209 Extensions to RSVP for Tunnels  
 RFC 3473 Generalized Multi-Protocol Label Switching (GMPLS) Signaling Resource Reservation Protocol-Traffic Engineering (RSVP-TE) Extensions –

(support of of IF\_ID RSVP\_HOP object with unnumbered interface and RSVP-TE Graceful Restart Helper Procedures)  
 RFC 3477 Signalling Unnumbered Links in Resource ReSerVation Protocol - Traffic Engineering (RSVP-TE)  
 RFC 3564 Requirements for Diff-Serv-aware TE  
 RFC 3906 Calculating Interior Gateway Protocol (IGP) Routes Over Traffic Engineering Tunnels  
 RFC 4090 Fast reroute Extensions to RSVP-TE for LSP Tunnels  
 RFC 4124 Protocol Extensions for Support of Diffserv-aware MPLS Traffic Engineering  
 RFC 4125 Maximum Allocation Bandwidth Constraints Model for Diffserv-aware MPLS Traffic Engineering  
 RFC 4127 Russian Dolls Bandwidth Constraints Model for Diffserv-aware MPLS Traffic Engineering  
 draft-newton-mpls-te-dynamic-overbooking-00 A Diffserv-TE Implementation Model to dynamically change booking factors during failure events  
 RFC 4561 Definition of a RRO Node-Id Sub-Object  
 RFC 4875 Extensions to Resource Reservation Protocol - Traffic Engineering (RSVP-TE) for Point-to-Multipoint TE Label Switched Paths (LSPs)  
 RFC 5151 Inter-domain MPLS and GMPLS Traffic Engineering – RSVP-TE Extensions  
 RFC 5712 MPLS Traffic Engineering Soft Preemption  
 RFC 5817 Graceful Shutdown in GMPLS Traffic Engineering Networks

#### **MPLS — OAM**

RFC 4379 Detecting Multi-Protocol Label Switched (MPLS) Data Plane Failures  
 RFC 6425 Detecting Data Plane Failures in Point-to-Multipoint Multiprotocol

#### **MPLS-TP**

RFC 5586 MPLS Generic Associated Channel  
 RFC 5921 A Framework for MPLS in Transport Networks  
 RFC 5960 MPLS Transport Profile Data Plane Architecture  
 RFC 6370 MPLS-TP Identifiers  
 RFC 6378 MPLS-TP Linear Protection  
 RFC 6428 Proactive Connectivity Verification, Continuity Check and Remote Defect indication for MPLS Transport Profile  
 RFC 6426 MPLS On-Demand Connectivity and Route Tracing  
 RFC 6478 Pseudowire Status for Static Pseudowires  
 draft-ietf-mpls-tp-ethernet-addressing-02 MPLS-TP Next-Hop Ethernet Addressing

#### **RIP**

RFC 1058 RIP Version 1  
 RFC 2082 RIP-2 MD5 Authentication  
 RFC 2453 RIP Version 2

#### **TCP/IP**

RFC 768 UDP  
 RFC 1350 The TFTP Protocol (Rev.  
 RFC 791 IP  
 RFC 792 ICMP  
 RFC 793 TCP  
 RFC 826 ARP  
 RFC 854 Telnet  
 RFC 951 BootP (rev)  
 RFC 1519 CIDR  
 RFC 1542 Clarifications and Extensions for the Bootstrap Protocol  
 RFC 1812 Requirements for IPv4 Routers  
 RFC 2347 TFTP option Extension  
 RFC 2328 TFTP Blocksize Option  
 RFC 2349 TFTP Timeout Interval and Transfer Size option  
 RFC 2401 Security Architecture for Internet Protocol  
 RFC 2428 FTP Extensions for IPv6 and NATs  
 RFC 3596 DNS Extensions to Support IP version 6

## Standards and Protocols

draft-ietf-bfd-mib-00.txt Bidirectional Forwarding Detection Management Information Base  
RFC 5880 Bidirectional Forwarding Detection  
RFC 5881 BFD IPv4 and IPv6 (Single Hop)  
RFC 5883 BFD for Multihop Paths  
RFC 5286 Basic Specification for IP Fast Reroute: Loop-Free Alternates

### VRRP

RFC 2787 Definitions of Managed Objects for the Virtual Router Redundancy Protocol  
RFC 3768 Virtual Router Redundancy Protocol  
draft-ietf-vrrp-unified-spec-02: Virtual Router Redundancy Protocol Version 3 for IPv4 and IPv6

### PPP

RFC 1332 PPP IPCP  
RFC 1377 PPP OSINLCP  
RFC 1638/2878 PPP BCP  
RFC 1661 PPP (rev RFC2151)  
RFC 1662 PPP in HDLC-like Framing  
RFC 1877 PPP Internet Protocol Control Protocol Extensions for Name Server Addresses  
RFC 1989 PPP Link Quality Monitoring  
RFC 1990 The PPP Multilink Protocol (MP)  
RFC 1994 "PPP Challenge Handshake Authentication Protocol (CHAP)  
RFC 2516 A Method for Transmitting PPP Over Ethernet  
RFC 2615 PPP over SONET/SDH  
RFC 2686 The Multi-Class Extension to Multi-Link PPP

### Frame Relay

FRF.1.2 - PVC User-to-Network Interface (UNI) Implementation Agreement  
FRF.5 - Frame Relay/ATM PVC Network Interworking Implementation  
ANSI T1.617 Annex D, DSS1 — Signalling Specification For Frame Relay Bearer Service.  
FRF2.2 - PVC Network-to-Network Interface (NNI) Implementation Agreement.

FRF.12 Frame Relay Fragmentation Implementation Agreement  
FRF.16.1 Multilink Frame Relay UNI/ NNI Implementation Agreement  
ITU-T Q.933 Annex A- Additional procedures for Permanent Virtual Connection (PVC) status management

### ATM

RFC 1626 Default IP MTU for use over ATM AAL5  
RFC 2514 Definitions of Textual Conventions and OBJECT\_IDENTITIES for ATM Management  
RFC 2515 Definition of Managed Objects for ATM Management  
RFC 2684 Multiprotocol Encapsulation over ATM Adaptation Layer 5  
AF-TM-0121.000 Traffic Management Specification Version 4.1  
ITU-T Recommendation I.610 - B-ISDN Operation and Maintenance Principles and Functions version 11/95  
ITU-T Recommendation I.432.1 – BISDN user-network interface – Physical layer specification: General characteristics  
GR-1248-CORE - Generic Requirements for Operations of ATM Network Elements (NEs). Issue 3  
GR-1113-CORE - Bellcore, Asynchronous Transfer Mode (ATM) and ATM Adaptation Layer (AAL) Protocols Generic Requirements, Issue 1  
AF-ILMI-0065.000 Integrated Local Management Interface (ILMI) Version 4.0  
AF-TM-0150.00 Addendum to Traffic Management v4.1 optional minimum desired cell rate indication for UBR  
AF-PHY-0086.001, Inverse Multiplexing for ATM (IMA) Specification Version 1.1

### DHCP

RFC 2131 Dynamic Host Configuration Protocol (REV)  
RFC 3046 DHCP Relay Agent Information Option (Option 82)

RFC 1534 Interoperation between DHCP and BOOTP

### Policy Management and Credit Control

3GPP TS 29.212 - Policy and Charging Control (PCC) over Gx/Sd Reference Point (Release 11) - Gx support as it applies to wireline environment (BNG)  
RFC 3588 – Diameter Base Protocol  
RFC 4006 – Diameter Credit Control Application

### NAT

RFC 6333 Dual-Stack Lite Broadband Deployments Following IPv4 Exhaustion  
RFC 6334 Dynamic Host Configuration Protocol for IPv6 (DHCPv6) Option for Dual-Stack Lite  
RFC 6888 Common Requirements For Carrier-Grade NATs (CGNs)  
RFC 5508 NAT Behavioral Requirements for ICMP  
RFC 5382 NAT Behavioral Requirements for TCP  
RFC 6146 Stateful NAT64

### VPLS

RFC 4762 Virtual Private LAN Services Using LDP  
RFC 5501: Requirements for Multicast Support in Virtual Private LAN Services (previously draft-ietf-l2vpn-vpls-mcast-reqts-04)  
RFC 6074: Provisioning, Auto-Discovery, and Signaling in Layer 2 Virtual Private Networks (L2VPNs) (previously draft-ietf-l2vpn-signaling-08)  
draft-ietf-l2vpn-vpls-mcast-13.txt Multicast in VPLS  
RFC 7041 Extensions to the Virtual Private LAN Service (VPLS) Provider Edge (PE) Model for Provider Backbone Bridging  
RFC 7117 Multicast in Virtual Private LAN Service (VPLS)

### Pseudowire

RFC 3985 Pseudo Wire Emulation Edge-to-Edge (PWE3)

RFC 4385 Pseudo Wire Emulation Edge-to-Edge (PWE3) Control Word for Use over an MPLS PSN

RFC 3916 Requirements for Pseudo-Wire Emulation Edge-to-Edge (PWE3)

RFC 4717 Encapsulation Methods for Transport ATM over MPLS Networks (draft-ietf-pwe3-atm-encap-10.txt)

RFC 4816 PWE3 ATM Transparent Cell Transport Service (draft-ietf-pwe3-cell-transport-04.txt)

RFC 4448 Encapsulation Methods for Transport of Ethernet over MPLS Networks (draft-ietf-pwe3-ethernet-encap-11.txt)

RFC 4619 Encapsulation Methods for Transport of Frame Relay over MPLS Networks (draft-ietf-pwe3-frame-relay-07.txt)

RFC 4446 IANA Allocations for PWE3

RFC 4447 Pseudowire Setup and Maintenance Using LDP (draft-ietf-pwe3-control-protocol-17.txt)

RFC 5085, Pseudowire Virtual Circuit Connectivity Verification (VCCV): A Control Channel for Pseudowires

RFC 5659 An Architecture for Multi-Segment Pseudowire Emulation Edge-to-Edge  
draft-ietf-l2vpn-vpws-iw-oam-03.txt, OAM Procedures for VPWS Interworking

draft-ietf-pwe3-mpls-eth-oam-iwk-07.txt, MPLS and Ethernet OAM Interworking RFC6073, Segmented Pseudowire

draft-ietf-pwe3-dynamic-ms-pw-16.txt , Dynamic Placement of Multi Segment Pseudo Wires

RFC 6310, Pseudowire (PW) OAM Message Mapping

RFC6391 Flow Aware Transport of Pseudowires over an MPLS PSN

RFC 6575, ARP Mediation for IP Interworking of Layer 2 VPN

RFC 6718, Pseudowire Redundancy

RFC 6870, Pseudowire Preferential Forwarding Status bit

MFA Forum 9.0.0 The Use of Virtual trunks for ATM/MPLS Control Plane Interworking

MFA Forum 12.0.0 Multiservice Interworking - Ethernet over MPLS

MFA forum 13.0.0 - Fault Management for Multiservice Interworking v1.0

MFA Forum 16.0.0 – Multiservice Interworking - IP over MPLS

#### **ANCP/L2CP**

RFC5851 ANCP framework  
draft-ietf-ancp-protocol-02.txt ANCP Protocol

#### **Voice /Video Performance:**

ITU-T G.107 The E Model- A computational model for use in planning.

ETSI TS 101 329-5 Annex E extensions- QoS Measurement for VoIP - Method for determining an Equipment Impairment Factor using Passive Monitoring

ITU-T Rec. P.564 - Conformance testing for voice over IP transmission quality assessment models

ITU-T G.1020 - Appendix I- Performance Parameter Definitions for Quality of Speech and other Voiceband Applications Utilizing IP Networks- Mean Absolute Packet Delay Variation.& Markov Models.

RFC 3550 Appendix A.8- RTP: A Transport Protocol for Real-Time Applications- Estimating the Interarrival Jitter.

#### **Circuit Emulation**

RFC 4553 Structure-Agnostic Time Division Multiplexing (TDM) over Packet (SAToP)

RFC 5086 Structure-Aware Time Division Multiplexed (TDM) Circuit Emulation Service over Packet Switched Network (CESoPSN)

MEF-8 Implementation Agreement for the Emulation of PDH Circuits over Metro Ethernet Networks, October 2004

RFC 5287 Control Protocol Extensions for the Setup of Time-Division Multiplexing (TDM) Pseudowires in MPLS Networks

#### **SONET/SDH**

ITU-G.841 Telecommunication Standardization Section of ITU, Types and Characteristics of SDH Networks Protection Architecture, issued in October 1998 and as augmented by Corrigendum1 issued in July 2002

#### **AAA**

RFC 2865 Remote Authentication Dial In User Service

RFC 2866 RADIUS Accounting  
draft-grant-tacacs-02.txt

#### **SSH**

RFC 4250 The Secure Shell (SSH) Protocol Protocol Assigned Numbers

RFC 4251 The Secure Shell (SSH) Protocol Architecture

RFC 4254 The Secure Shell (SSH) Connection Protocol

#### **OpenFlow**

ONF OpenFlow Switch Specification version 1.3.1 (Hybrid-switch/ FlowTable)

#### **Timing**

GR-253-CORE SONET Transport Systems: Common Generic Criteria. Issue 3, September 2000

ITU-T G.781 Telecommunication Standardization Section of ITU, Synchronization layer functions, issued 09/2008

ITU-T G.813 Telecommunication Standardization Section of ITU, Timing characteristics of SDH equipment slave clocks (SEC), issued 03/2003.

GR-1244-CORE Clocks for the Synchronized Network: Common Generic Criteria, Issue 3, May 2005

ITU-T G.8261 Telecommunication Standardization Section of ITU, Timing and synchronization aspects in packet networks, issued 04/2008.

ITU-T G.8262 Telecommunication Standardization Section of ITU, Timing characteristics of synchronous Ethernet equipment slave clock (EEC), issued 08/2007.

## Standards and Protocols

ITU-T G.8264 Telecommunication Standardization Section of ITU, Distribution of timing information through packet networks, issued 10/2008.

ITU-T G.8265.1 Telecommunication Standardization Section of ITU, Precision time protocol telecom profile for frequency synchronization, issued 10/2010.

IEEE 1588-2008, IEEE Standard for a Precision Clock Synchronization Protocol for Networked Measurement and Control Systems

### Network Management

ITU-T X.721: Information technology-OSI-Structure of Management Information

ITU-T X.734: Information technology-OSI-Systems Management: Event Report Management Function

M.3100/3120 Equipment and Connection Models

TMF 509/613 Network Connectivity Model

RFC 1157 SNMPv1

RFC 1215 A Convention for Defining Traps for use with the SNMP

RFC 1657 BGP4-MIB

RFC 1724 RIPv2-MIB

RFC 1850 OSPF-MIB

RFC 1907 SNMPv2-MIB

RFC 2011 IP-MIB

RFC 2138 RADIUS

RFC 2206 RSVP-MIB

RFC 2452 IPv6 Management Information Base for the Transmission Control Protocol

RFC 2465 Management Information Base for IPv6: Textual Conventions and General Group

RFC 2558 SONET-MIB

RFC 2571 SNMP-FRAMEWORKMIB

RFC 2572 SNMP-MPD-MIB

RFC 2573 SNMP-TARGET-&-NOTIFICATION-MIB

RFC 2574 SNMP-USER-BASED-SMMIB

RFC 2575 SNMP-VIEW-BASED-ACM-MIB

RFC 2576 SNMP-COMMUNITY-MIB

RFC 2578 Structure of Management Information Version 2 (SMIv2)

RFC 2665 EtherLike-MIB

RFC 2819 RMON-MIB

RFC 2863 IF-MIB

RFC 2864 INVERTED-STACK-MIB

RFC 2987 VRRP-MIB

RFC 3014 NOTIFICATION-LOGMIB

RFC 3019 IP Version 6 Management Information Base for The Multicast Listener Discovery Protocol

RFC 3164 Syslog

RFC 3273 HCRMON-MIB

RFC 3411 An Architecture for Describing Simple Network Management Protocol (SNMP) Management Frameworks

RFC 3412 - Message Processing and Dispatching for the Simple Network Management Protocol (SNMP)

RFC 3413 - Simple Network Management Protocol (SNMP) Applications

RFC 3414 - User-based Security Model (USM) for version 3 of the Simple Network Management Protocol (SNMPv3)

RFC 3418 - SNMP MIB

RFC 3826 The Advanced Encryption Standard (AES) Cipher Algorithm in the SNMP User-based Security Model

RFC 4113 Management Information Base for the User Datagram Protocol (UDP)

RFC 4292 IP-FORWARD-MIB

RFC 4293 MIB for the Internet Protocol

RFC 5101 - Specification of the IP Flow Information Export (IPFIX) Protocol for the Exchange of IP Traffic Flow Information

RFC 6241: NETCONF Configuration Protocol

RFC 6242 Using the NETCONF Protocol over Secure Shell (SSH)

draft-ietf-ospf-mib-update-04.txt

draft-ietf-mpls-lsr-mib-06.txt

draft-ietf-mpls-te-mib-04.txt

draft-ietf-mpls-ldp-mib-07.txt

draft-ietf-isis-wg-mib-06 Management Information Base for Intermediate System to Intermediate System (IS-

IS)  
IANA-IFType-MIB  
IEEE8023-LAG-MIB

# Index

## NUMERICS

- 802.1x 30
- 802.3ah OAM 68

## C

- card commands 102
- Card, MDA, Port
  - overview 16
    - chassis slots and cards 16
    - MDAs 17
    - MTU configuration guidelines 73
    - preprovisioning
      - chassis slots and cards 16
- configuring
  - basic 83
  - LAG 95
  - management tasks 97
  - MDA pool parameters 87
  - port
    - Ethernet 92
      - access port 93
      - network port 92
    - pool parameters 88
    - SONET/SDH 94
  - command reference
    - card commands 102, 104
    - MDA commands 102, 104

- port commands 107
- SONET/SDH commands 114
- ports 88

## D

- DDM 19

## E

- E-LMI 37

## H

- hashing 50

## L

- LAG 42
  - configuring 95
  - command reference 115
  - hashing 50

## P

- port types 26
- ports
  - 26
  - features 28
  - types 26

