



# 7705 Service Aggregation Router

Release 24.10.R1

## Routing Protocols Guide

---

3HE 20400 AAAB TQZZA

Edition: 01

October 2024

© 2024 Nokia.

Use subject to Terms available at: [www.nokia.com/terms](http://www.nokia.com/terms).

Nokia is committed to diversity and inclusion. We are continuously reviewing our customer documentation and consulting with standards bodies to ensure that terminology is inclusive and aligned with the industry. Our future customer documentation will be updated accordingly.

---

This document includes Nokia proprietary and confidential information, which may not be distributed or disclosed to any third parties without the prior written consent of Nokia.

This document is intended for use by Nokia's customers ("You"/"Your") in connection with a product purchased or licensed from any company within Nokia Group of Companies. Use this document as agreed. You agree to notify Nokia of any errors you may find in this document; however, should you elect to use this document for any purpose(s) for which it is not intended, You understand and warrant that any determinations You may make or actions You may take will be based upon Your independent judgment and analysis of the content of this document.

Nokia reserves the right to make changes to this document without notice. At all times, the controlling version is the one available on Nokia's site.

No part of this document may be modified.

NO WARRANTY OF ANY KIND, EITHER EXPRESS OR IMPLIED, INCLUDING BUT NOT LIMITED TO ANY WARRANTY OF AVAILABILITY, ACCURACY, RELIABILITY, TITLE, NON-INFRINGEMENT, MERCHANTABILITY OR FITNESS FOR A PARTICULAR PURPOSE, IS MADE IN RELATION TO THE CONTENT OF THIS DOCUMENT. IN NO EVENT WILL NOKIA BE LIABLE FOR ANY DAMAGES, INCLUDING BUT NOT LIMITED TO SPECIAL, DIRECT, INDIRECT, INCIDENTAL OR CONSEQUENTIAL OR ANY LOSSES, SUCH AS BUT NOT LIMITED TO LOSS OF PROFIT, REVENUE, BUSINESS INTERRUPTION, BUSINESS OPPORTUNITY OR DATA THAT MAY ARISE FROM THE USE OF THIS DOCUMENT OR THE INFORMATION IN IT, EVEN IN THE CASE OF ERRORS IN OR OMISSIONS FROM THIS DOCUMENT OR ITS CONTENT.

Copyright and trademark: Nokia is a registered trademark of Nokia Corporation. Other product names mentioned in this document may be trademarks of their respective owners.

© 2024 Nokia.

# Table of contents

<b>List of tables</b> .....	<b>16</b>
<b>List of figures</b> .....	<b>21</b>
<b>1 Preface</b> .....	<b>24</b>
1.1 Audience.....	24
1.2 Technical support.....	24
<b>2 7705 SAR routing configuration process</b> .....	<b>26</b>
<b>3 IP multicast</b> .....	<b>27</b>
3.1 Overview of IP multicast.....	27
3.1.1 Multicast in IP-VPN networks.....	28
3.1.2 Mobile backhaul IP multicast example.....	28
3.1.3 Multicast models (ASM and SSM).....	29
3.1.3.1 ASM.....	29
3.1.3.2 SSM.....	29
3.1.4 IGMP snooping and MLD snooping for VPLS and routed VPLS.....	30
3.1.5 Multicast over Layer 3 spoke SDP interfaces.....	30
3.2 IGMP.....	30
3.2.1 IGMP overview.....	30
3.2.2 IGMP versions and interoperability requirements.....	31
3.2.3 IGMP version transition.....	31
3.2.4 Query messages.....	32
3.2.5 Source-specific multicast groups (IPv4).....	32
3.3 MLD.....	32
3.3.1 MLD overview.....	32
3.3.2 MLDv1.....	33
3.3.3 MLDv2.....	33
3.4 PIM.....	33
3.4.1 PIM-SM overview.....	34
3.4.2 PIM-SM functions.....	34
3.4.2.1 Phase one.....	34
3.4.2.2 Phase two.....	35

3.4.2.3	Phase three.....	36
3.4.3	Encapsulating data packets in the register tunnel.....	36
3.4.4	PIM bootstrap router mechanism.....	36
3.4.5	PIM-SM routing policies.....	37
3.4.6	Reverse path forwarding checks.....	38
3.4.7	Anycast RP for PIM-SM.....	38
3.4.7.1	Implementation.....	38
3.4.8	Multicast-only fast reroute (MoFRR).....	40
3.4.9	Automatic discovery of group-to-RP mappings (auto-RP).....	41
3.5	IPv6 PIM models.....	42
3.5.1	PIM-SSM.....	42
3.5.2	PIM-ASM.....	42
3.6	IP multicast debugging tools.....	42
3.6.1	Mtrace.....	42
3.6.1.1	Finding the last-hop router.....	43
3.6.1.2	Directing the response.....	44
3.6.2	Mstat.....	44
3.6.3	Mrinfo.....	44
3.7	MSDP.....	45
3.7.1	MSDP and anycast RP.....	46
3.7.2	MSDP procedure.....	46
3.7.2.1	MSDP peering scenarios.....	46
3.7.3	MSDP peer groups.....	47
3.7.4	MSDP mesh groups.....	47
3.7.5	MSDP routing policies.....	47
3.7.6	Auto-RP (discovery mode only) in multicast VPN.....	47
3.8	Inter-AS non-segmented mLDP.....	48
3.8.1	ASBR support of PE functionality.....	48
3.9	Hashing for inter-AS.....	49
3.10	Hashing at the ASBR.....	49
3.11	Unicast and multicast address translation.....	50
3.11.1	Unicast-to-multicast address translation.....	51
3.11.2	Multicast-to-multicast address translation.....	54
3.12	IP multicast configuration process overview.....	56
3.13	Configuration notes.....	56
3.14	Configuring IP multicast parameters with CLI.....	56

3.15	IP multicast configuration overview.....	57
3.15.1	IGMP and MLD.....	57
3.15.1.1	Static groups.....	57
3.15.1.2	SSM translation.....	57
3.15.2	PIM.....	58
3.15.3	Hardware support.....	58
3.16	Basic IP multicast configuration.....	58
3.17	Common configuration tasks.....	62
3.17.1	Configuring IGMP and MLD parameters.....	62
3.17.1.1	Enabling IGMP or MLD.....	63
3.17.1.2	Configuring IGMP and MLD.....	63
3.17.1.3	Configuring IGMP and MLD interfaces.....	64
3.17.1.4	Configuring IGMP and MLD interface static multicast.....	65
3.17.1.5	Configuring IGMP and MLD SSM translation.....	66
3.17.2	Configuring PIM parameters.....	67
3.17.2.1	Enabling PIM.....	67
3.17.2.2	Configuring PIM interface parameters.....	69
3.17.2.3	Configuring a rendezvous point (RP).....	70
3.17.2.4	Importing PIM join or register policies.....	71
3.17.2.5	Configuring MSDP parameters.....	72
3.18	Service management tasks.....	72
3.18.1	Disabling IGMP, MLD, PIM, and MSDP.....	72
3.19	IP multicast command reference.....	75
3.19.1	Command hierarchies.....	75
3.19.1.1	Configuration commands.....	75
3.19.1.2	Show commands.....	79
3.19.1.3	Clear commands.....	80
3.19.1.4	Monitor commands.....	80
3.19.1.5	Debug commands.....	80
3.19.2	Command descriptions.....	83
3.19.2.1	Configuration commands.....	83
3.19.2.2	Show commands.....	140
3.19.2.3	Clear commands.....	197
3.19.2.4	Monitor commands.....	204
3.19.2.5	Debug commands.....	205

<b>4</b>	<b>OSPF</b>	<b>222</b>
4.1	Overview of OSPF	222
4.1.1	OSPF areas	223
4.1.1.1	Backbone area	224
4.1.1.2	Super backbone area	224
4.1.1.3	Area border router	227
4.1.1.4	Stub area	228
4.1.1.5	Not-so-stubby area	228
4.1.2	Virtual links	228
4.1.3	Neighbors and adjacencies	229
4.1.3.1	Designated routers and backup designated routers	229
4.1.4	Link-state advertisements	229
4.1.5	Metrics	231
4.1.6	Authentication	231
4.1.6.1	Authentication key	231
4.1.6.2	Authentication keychains	232
4.1.7	Route redistribution and summarization	233
4.1.8	OSPF-TE extensions	233
4.1.9	Unnumbered interfaces	233
4.1.10	IP subnets	233
4.1.11	OSPF instances	234
4.1.12	Multi-area adjacencies	234
4.1.13	OSPF import policies	235
4.2	Bidirectional forwarding detection (BFD) for OSPF	235
4.3	Graceful restart helper	235
4.4	LFA protection using segment routing backup node SID	236
4.4.1	Configuring LFA using backup node SID	237
4.4.2	Detailed operation of LFA protection using backup node SID	238
4.4.3	Duplicate SID handling	240
4.4.4	OSPF control plane extensions	240
4.4.5	Topology-independent LFA for OSPF	242
4.5	LDP and IP fast reroute (FRR) for OSPF prefixes	242
4.5.1	LFA calculations	243
4.5.1.1	Selection algorithm	244
4.5.1.2	LFA configuration	245

---

4.5.2	IGP shortcuts (RSVP-TE tunnels).....	246
4.5.2.1	Selection algorithm.....	246
4.5.2.2	Forwarding adjacency.....	247
4.5.2.3	IGP shortcut configuration.....	248
4.5.3	LFA SPF policies.....	248
4.5.3.1	LFA SPF policy configuration.....	248
4.6	Preconfiguration requirements.....	249
4.7	OSPF configuration process overview.....	249
4.8	Configuration notes.....	250
4.9	Configuring OSPF with CLI.....	250
4.10	OSPF configuration guidelines.....	251
4.11	Basic OSPF configuration.....	251
4.11.1	Configuring the router ID.....	252
4.11.2	Configuring an OSPF area.....	252
4.11.3	Configuring an interface.....	253
4.12	Configuring other OSPF components.....	254
4.12.1	Configuring a stub area.....	255
4.12.2	Configuring a not-so-stubby area.....	255
4.12.3	Configuring a virtual link.....	256
4.12.4	Configuring authentication.....	257
4.12.5	Assigning a designated router.....	258
4.12.6	Configuring route summaries.....	259
4.12.7	Configuring route preferences.....	259
4.13	OSPF configuration management tasks.....	260
4.13.1	Modifying a router ID.....	261
4.13.2	Deleting a router ID.....	261
4.13.3	Modifying OSPF parameters.....	261
4.14	OSPF command reference.....	263
4.14.1	Command hierarchies.....	263
4.14.1.1	Configuration commands.....	263
4.14.1.2	Show commands.....	267
4.14.1.3	Clear commands.....	268
4.14.1.4	Monitor commands.....	268
4.14.1.5	Debug commands.....	268
4.14.2	Command descriptions.....	270
4.14.2.1	Configuration commands.....	270

4.14.2.2	Show commands.....	328
4.14.2.3	Clear commands.....	390
4.14.2.4	Monitor commands.....	393
4.14.2.5	Debug commands.....	402
<b>5</b>	<b>IS-IS.....</b>	<b>410</b>
5.1	Overview of IS-IS.....	410
5.1.1	IS-IS areas (two-level hierarchy).....	411
5.1.2	ISO network addressing.....	413
5.1.3	Neighbors and adjacencies.....	414
5.1.3.1	Designated routers.....	415
5.1.3.2	IS-IS packet types.....	416
5.1.4	Metrics.....	417
5.1.5	Authentication.....	417
5.1.5.1	Authentication key.....	418
5.1.5.2	Authentication keychains.....	418
5.1.6	Route redistribution and summarization.....	419
5.1.6.1	Route redistribution.....	419
5.1.6.2	Route summarization.....	419
5.1.7	IS-IS-TE extensions.....	420
5.1.8	Unnumbered interfaces.....	420
5.1.9	Multitopology IS-IS.....	420
5.1.10	Segment routing in shortest path forwarding.....	421
5.1.10.1	Configuring segment routing in shortest path.....	421
5.1.10.2	Segment routing operational procedures.....	425
5.1.10.3	Segment routing tunnel management.....	431
5.1.10.4	Remote LFA with segment routing.....	433
5.1.10.5	Topology-independent LFA.....	436
5.1.10.6	Node protection support in remote LFA and TI-LFA.....	441
5.1.10.7	IPv6 segment routing using MPLS encapsulation.....	446
5.1.10.8	Data path support.....	448
5.1.10.9	Control protocol changes.....	449
5.1.10.10	BGP label route resolution using segment routing tunnel.....	454
5.1.10.11	Service packet forwarding with segment routing.....	454
5.1.10.12	Segment routing mapping server for IPv4 /32 prefixes (IS-IS).....	455
5.1.10.13	Mirror services.....	456



5.1.11	Multi-instance IS-IS (MI-IS-IS).....	457
5.1.12	IPv6 support.....	457
5.2	Bidirectional forwarding detection (BFD) for IS-IS.....	457
5.3	LDP and IP fast reroute (FRR) for IS-IS prefixes.....	458
5.3.1	LFA calculations.....	458
5.3.1.1	Selection algorithm.....	460
5.3.1.2	LFA configuration.....	461
5.3.2	IGP shortcuts (RSVP-TE tunnels).....	461
5.3.2.1	Selection algorithm.....	462
5.3.2.2	Forwarding adjacency.....	462
5.3.2.3	IGP shortcut configuration.....	463
5.3.3	LFA SPF policies.....	463
5.3.3.1	LFA SPF policy configuration.....	464
5.4	IS-IS configuration process overview.....	464
5.5	Configuration notes.....	465
5.6	Configuring IS-IS with CLI.....	465
5.7	IS-IS configuration overview.....	465
5.8	Basic IS-IS configuration.....	465
5.9	Configuring IS-IS components.....	467
5.9.1	Enabling IS-IS.....	467
5.9.2	Configuring an IS-IS instance level.....	468
5.9.3	Configuring ISO area addresses.....	468
5.9.4	Configuring global IS-IS parameters.....	469
5.9.5	Configuring interface parameters.....	470
5.9.5.1	Example 1: configuring a level 1 area.....	471
5.9.5.2	Example 2: modifying router level capability.....	472
5.9.5.3	Interface level capability.....	473
5.9.6	Configuring authentication.....	473
5.9.7	Configuring leaking.....	475
5.9.8	Redistributing external IS-IS routes.....	476
5.9.9	Configuring IS-IS support for LDP-to-SR stitching.....	477
5.9.10	Configuring an SR mapping server for IPv4 /32 prefixes.....	478
5.10	IS-IS configuration management tasks.....	478
5.10.1	Disabling IS-IS.....	478
5.10.2	Removing IS-IS.....	479
5.10.3	Modifying global IS-IS parameters.....	479

5.10.4	Modifying IS-IS interface parameters.....	480
5.11	IS-IS command reference.....	482
5.11.1	Command hierarchies.....	482
5.11.1.1	Configuration commands.....	482
5.11.1.2	Show commands.....	485
5.11.1.3	Clear commands.....	485
5.11.1.4	Monitor commands.....	486
5.11.1.5	Debug commands.....	486
5.11.2	Command descriptions.....	487
5.11.2.1	Configuration commands.....	487
5.11.2.2	Show commands.....	552
5.11.2.3	Clear commands.....	588
5.11.2.4	Monitor commands.....	590
5.11.2.5	Debug commands.....	592
<b>6</b>	<b>BGP.....</b>	<b>598</b>
6.1	BGP overview.....	598
6.1.1	BGP communication.....	599
6.1.1.1	Static and dynamic neighbors.....	599
6.1.2	Message types.....	600
6.1.2.1	Update message error handling.....	601
6.1.3	BGP path attributes.....	602
6.1.3.1	Origin attribute.....	603
6.1.3.2	AS path attribute.....	603
6.1.3.3	Next-hop attribute.....	603
6.1.3.4	MED attribute.....	606
6.1.3.5	Local preference attribute.....	606
6.1.3.6	Route aggregation path attributes.....	607
6.1.3.7	Communities attribute.....	607
6.1.3.8	Route reflection attributes.....	607
6.1.3.9	Multiprotocol BGP extensions attributes.....	608
6.1.3.10	4-octet AS attributes.....	608
6.1.3.11	AIGP metric attribute.....	608
6.1.4	Multiprotocol BGP attributes.....	609
6.1.5	BGPv6.....	610
6.1.6	BGP add-paths.....	610

6.1.6.1	Path selection mode and parameters for multiple paths to add-path peers.....	611
6.1.6.2	Routing policy for multiple paths.....	612
6.1.6.3	BGP route advertisement rules for multiple paths.....	612
6.1.6.4	BGP split horizon.....	612
6.1.7	Outbound route filtering (ORF).....	612
6.1.8	BGP route target constrained route distribution.....	613
6.2	Group configuration and peers.....	614
6.2.1	Hierarchical levels.....	615
6.2.2	Route reflection.....	615
6.2.3	BGP peer groups with dynamic neighbors.....	617
6.2.4	Fast external failover.....	618
6.2.5	BGP fast reroute with prefix-independent convergence.....	618
6.2.5.1	BGP FRR failure detection and switchover.....	619
6.2.6	Calculating backup paths.....	620
6.2.7	Sending of BGP communities.....	620
6.2.8	BGP decision process.....	620
6.3	BGP route tunnels.....	621
6.3.1	Route reflector next-hop-self for IP-VPNv4/6 routes over IPv4 LU.....	622
6.3.2	BGP labeled unicast selective download.....	623
6.3.3	Layer 2 services and BGP route tunnel.....	624
6.3.4	BGP route tunnel SDP binding.....	625
6.3.5	BGP route tunnel with multihop EBGp resolution.....	625
6.3.6	Next-hop resolution of BGP labeled routes to tunnels.....	625
6.3.7	BGP next-hop resolution and peer tracking.....	626
6.3.8	BGP route installation in the route table.....	626
6.3.9	BGP link state.....	627
6.3.9.1	Supported BGP-LS components.....	628
6.4	Command interactions and dependencies.....	630
6.4.1	Changing the autonomous system number.....	630
6.4.2	Changing the local AS number.....	630
6.4.3	Changing the router ID at the configuration level.....	630
6.4.4	Hold time and keepalive timer dependencies.....	631
6.4.5	Import and export route policies.....	631
6.4.6	AS override.....	631
6.4.7	TCP MD5 authentication.....	632
6.4.8	TTL security.....	632

6.4.9	Advertise-inactive.....	633
6.4.10	Advertise-inactive, add-paths, and export policy interaction.....	633
6.5	BGP configuration process overview.....	633
6.6	Configuration notes.....	634
6.6.1	General.....	634
6.6.2	BGP defaults.....	634
6.6.3	BGP MIB notes.....	635
6.7	Configuring BGP with CLI.....	636
6.8	BGP configuration overview.....	636
6.8.1	Preconfiguration requirements.....	636
6.8.2	BGP hierarchy.....	637
6.8.3	Internal and external BGP configurations.....	637
6.8.4	BGP route reflectors.....	637
6.9	Basic BGP configuration.....	639
6.10	Common configuration tasks.....	641
6.10.1	Creating an autonomous system.....	641
6.10.2	Configuring a router ID.....	642
6.11	BGP components.....	643
6.11.1	Configuring BGP.....	643
6.11.2	Configuring group attributes.....	644
6.11.3	Configuring neighbor attributes.....	645
6.11.4	Configuring BGP address families.....	646
6.11.5	Configuring route reflection.....	647
6.11.6	Configuring a BGP peer group with dynamic neighbors.....	648
6.12	BGP configuration management tasks.....	649
6.12.1	Modifying an AS number.....	649
6.12.2	Modifying the BGP router ID.....	650
6.12.3	Modifying the router-level router ID.....	650
6.12.4	Deleting a neighbor.....	651
6.12.5	Deleting groups.....	652
6.12.6	Editing BGP parameters.....	653
6.13	BGP command reference.....	654
6.13.1	Command hierarchies.....	654
6.13.1.1	Configuration commands.....	654
6.13.1.2	Show commands.....	660
6.13.1.3	Clear commands.....	661

6.13.1.4	Debug commands.....	662
6.13.2	Command descriptions.....	663
6.13.2.1	Configuration commands.....	663
6.13.2.2	Show commands.....	726
6.13.2.3	Clear commands.....	793
6.13.2.4	Debug commands.....	795
<b>7</b>	<b>RIP.....</b>	<b>801</b>
7.1	RIP overview.....	801
7.1.1	RIP versions.....	802
7.1.2	RIPv2 authentication.....	802
7.1.3	Metrics.....	802
7.1.4	Timers.....	802
7.1.5	Import and export policies.....	803
7.1.6	RIP packet format.....	803
7.1.7	RIP hierarchical levels.....	804
7.2	RIP configuration process overview.....	805
7.3	Configuration notes.....	805
7.4	Configuring RIP with CLI.....	805
7.5	RIP configuration overview.....	806
7.5.1	Preconfiguration requirements.....	806
7.6	Basic RIP configuration.....	806
7.7	Common configuration tasks.....	807
7.7.1	Configuring interfaces.....	807
7.7.2	Configuring a route policy.....	808
7.8	Configuring RIP parameters.....	810
7.8.1	Configuring global-level parameters.....	811
7.8.2	Configuring group-level parameters.....	811
7.8.3	Configuring neighbor-level parameters.....	812
7.9	RIP configuration management tasks.....	812
7.9.1	Modifying RIP parameters.....	812
7.9.2	Deleting a RIP group.....	813
7.9.3	Deleting a RIP neighbor.....	813
7.10	RIP command reference.....	815
7.10.1	Command hierarchies.....	815
7.10.1.1	Configuration commands.....	815

7.10.1.2	Show commands.....	817
7.10.1.3	Clear commands.....	817
7.10.1.4	Monitor commands.....	817
7.10.1.5	Debug commands.....	817
7.10.2	Command descriptions.....	819
7.10.2.1	Configuration commands.....	819
7.10.2.2	Show commands.....	833
7.10.2.3	Clear commands.....	844
7.10.2.4	Monitor commands.....	845
7.10.2.5	Debug commands.....	846
<b>8</b>	<b>List of acronyms.....</b>	<b>850</b>
<b>9</b>	<b>Supported standards and protocols.....</b>	<b>877</b>
9.1	Security standards.....	877
9.2	Telecom standards.....	877
9.3	Protocol support.....	878
9.3.1	ATM.....	878
9.3.2	BFD.....	878
9.3.3	BGP.....	879
9.3.4	DHCP/DHCPv6.....	879
9.3.5	Differentiated services.....	880
9.3.6	Digital data network management.....	880
9.3.7	ECMP.....	880
9.3.8	Ethernet VPN (EVPN).....	880
9.3.9	Frame relay.....	880
9.3.10	GRE.....	880
9.3.11	Internet protocol (IP) – version 4.....	880
9.3.12	Internet protocol (IP) – version 6.....	881
9.3.13	IPSec.....	881
9.3.14	IS-IS.....	882
9.3.15	LDP.....	882
9.3.16	LDP and IP FRR.....	883
9.3.17	MPLS.....	883
9.3.18	MPLS – OAM.....	884
9.3.19	Multicast.....	884

---

9.3.20	Network management.....	884
9.3.21	OSPF.....	885
9.3.22	OSPFv3.....	886
9.3.23	PPP.....	886
9.3.24	Pseudowires.....	886
9.3.25	RIP.....	887
9.3.26	RADIUS.....	887
9.3.27	RSVP-TE and FRR.....	887
9.3.28	Segment routing (SR).....	888
9.3.29	SONET/SDH.....	888
9.3.30	SSH.....	888
9.3.31	Synchronization.....	888
9.3.32	TACACS+.....	889
9.3.33	TLS.....	889
9.3.34	TWAMP.....	889
9.3.35	VPLS.....	889
9.3.36	VRRP.....	890
9.4	Proprietary MIBs.....	890

# List of tables

Table 1: Configuration process.....	26
Table 2: Join filter policy match conditions.....	37
Table 3: Register filter policy match conditions.....	37
Table 4: PE features on ASBRs.....	48
Table 5: Multicast destination address range.....	113
Table 6: IGMP group field descriptions.....	142
Table 7: IGMP interface field descriptions.....	144
Table 8: IGMP SSM-translate field descriptions.....	147
Table 9: Static IGMP field descriptions.....	148
Table 10: IGMP statistics field descriptions.....	149
Table 11: IGMP status field descriptions.....	151
Table 12: MLD group field descriptions.....	153
Table 13: MLD interface field descriptions.....	156
Table 14: MLD SSM-translate field descriptions.....	159
Table 15: MLD static group field descriptions.....	160
Table 16: MLD statistics field descriptions.....	161
Table 17: MLD status field descriptions.....	163
Table 18: PIM group field descriptions.....	165
Table 19: PIM interface field descriptions.....	171
Table 20: PIM neighbor field descriptions.....	175
Table 21: RP field descriptions.....	176



---

Table 22: RP hash field descriptions.....	177
Table 23: S-PMSI field descriptions.....	180
Table 24: PIM statistics field descriptions.....	182
Table 25: PIM status field descriptions.....	185
Table 26: MSDP group field descriptions.....	187
Table 27: MSDP peer field descriptions.....	189
Table 28: MSDP source field descriptions.....	190
Table 29: MSDP SA field descriptions.....	192
Table 30: MSDP source-active field descriptions.....	194
Table 31: MSDP statistics field descriptions.....	195
Table 32: MSDP status field descriptions.....	196
Table 33: LSA types.....	230
Table 34: Handling of duplicate SIDs .....	240
Table 35: OSPF control plane extension fields .....	241
Table 36: OSPF control plane extension flags .....	241
Table 37: Route preference defaults by route type.....	260
Table 38: Route preference defaults by route type.....	279
Table 39: Area field descriptions.....	330
Table 40: Area LFA field descriptions.....	332
Table 41: Router capabilities field descriptions.....	334
Table 42: Database field descriptions.....	337
Table 43: Interface field descriptions.....	339
Table 44: Detailed interface field descriptions.....	341

---

Table 45: LFA coverage field descriptions.....	347
Table 46: Neighbor field descriptions.....	349
Table 47: Neighbor (detail) field descriptions.....	350
Table 48: Neighbor (overview) field descriptions.....	353
Table 49: OSPF opaque database field descriptions .....	357
Table 50: Prefix SIDs field descriptions.....	359
Table 51: Area range field descriptions.....	360
Table 52: OSPF sham link field descriptions (standard).....	365
Table 53: OSPF sham link field descriptions (detailed).....	366
Table 54: OSPF sham-link neighbor field descriptions (standard).....	370
Table 55: OSPF sham-link neighbor field descriptions (detailed).....	371
Table 56: SPF field descriptions.....	375
Table 57: OSPF statistics field descriptions.....	377
Table 58: OSPF status field descriptions.....	381
Table 59: Virtual link field descriptions.....	385
Table 60: Virtual neighbor field descriptions.....	389
Table 61: IS-IS intermediate systems.....	413
Table 62: IS-IS packet types.....	416
Table 63: Data path support .....	448
Table 64: Potential adjacency capabilities.....	473
Table 65: Route preference defaults by route type.....	505
Table 66: Potential adjacency capabilities.....	508
Table 67: Adjacency field descriptions.....	554

---

Table 68: IS-IS capabilities field descriptions.....	556
Table 69: Database summary field descriptions.....	557
Table 70: Database detailed field descriptions.....	559
Table 71: Hostname database field descriptions.....	561
Table 72: Interface field descriptions.....	562
Table 73: Interface detailed field descriptions.....	563
Table 74: LFA coverage field descriptions.....	565
Table 75: Prefix SIDs field descriptions.....	568
Table 76: Routing table field descriptions.....	571
Table 77: SPF log field descriptions.....	573
Table 78: IS-IS statistics field descriptions.....	575
Table 79: IS-IS status field descriptions.....	579
Table 80: Summary address field descriptions.....	584
Table 81: IS-IS topology field descriptions.....	588
Table 82: Multiprotocol BGP support on the 7705 SAR.....	609
Table 83: BGP FRR scenarios .....	619
Table 84: BGP-LU selective download logic by service type.....	623
Table 85: 7705 SAR and IETF MIB variations.....	635
Table 86: MIB variable with SNMP.....	635
Table 87: BGP auth-keychain field descriptions.....	728
Table 88: BGP damping field descriptions.....	732
Table 89: BGP group field descriptions.....	736
Table 90: Inter-AS service label field descriptions.....	739

---

Table 91: BGP neighbor (standard, detailed, and dynamic) field descriptions.....	746
Table 92: BGP neighbor (advertised-routes and received-routes) field descriptions.....	756
Table 93: BGP neighbor (graceful restart) field descriptions.....	757
Table 94: BGP next-hop field descriptions.....	760
Table 95: BGP path field descriptions.....	762
Table 96: BGP route field descriptions.....	785
Table 97: BGP summary field descriptions.....	791
Table 98: RIP database field descriptions.....	834
Table 99: RIP group field descriptions.....	836
Table 100: RIP neighbor field descriptions.....	838
Table 101: RIP neighbor (detailed) field descriptions.....	839
Table 102: RIP peer field descriptions.....	841
Table 103: RIP statistics field descriptions.....	843
Table 104: Acronyms.....	850

# List of figures

Figure 1: IP multicast for MBMS.....	28
Figure 2: Anycast RP for PIM-SM implementation.....	39
Figure 3: MoFRR in steady state with no failure.....	41
Figure 4: MoFRR in failure state.....	41
Figure 5: Remote and local ASBRs.....	48
Figure 6: Hashing for inter-AS.....	49
Figure 7: Hashing at the ASBR.....	50
Figure 8: Unicast-to-multicast translation on the 7705 SAR.....	52
Figure 9: Multicast-to-multicast address translation on the 7705 SAR.....	54
Figure 10: IP multicast configuration process.....	56
Figure 11: Backbone area.....	224
Figure 12: PE routers connected to an MPLS VPN super backbone.....	225
Figure 13: Sham link.....	226
Figure 14: Multi-area adjacency.....	234
Figure 15: Label stack for remote LFA in ring topology.....	237
Figure 16: Backup ABR node SID.....	238
Figure 17: Backup routes resulting in microloops.....	244
Figure 18: LFA backup route.....	244
Figure 19: OSPF configuration process.....	250
Figure 20: IS-IS topology.....	412
Figure 21: Using area addresses to form adjacencies.....	415

Figure 22: Packet label encapsulation using segment routing tunnel.....	422
Figure 23: Programming multiple tunnels to the same destination.....	427
Figure 24: Handling of same prefix and SID in different IS-IS instances.....	430
Figure 25: Remote LFA algorithm.....	434
Figure 26: Remote LFA next hop in segment routing.....	435
Figure 27: Selecting link-protect TI-LFA backup path.....	438
Figure 28: TI-LFA backup path via a pseudonode.....	440
Figure 29: Parallel adjacencies between P and Q nodes.....	441
Figure 30: Application of the TI-LFA algorithm for node protection.....	442
Figure 31: Application of the remote LFA algorithm for node protection.....	445
Figure 32: Transport label stack in shortest path forwarding with segment routing.....	449
Figure 33: Backup routes resulting in microloops.....	459
Figure 34: LFA backup route.....	460
Figure 35: IS-IS configuration process.....	464
Figure 36: Configuring a level 1 area.....	471
Figure 37: Configuring a level 1/2 area.....	473
Figure 38: BGP configuration.....	599
Figure 39: BGPv6.....	610
Figure 40: BGP update message with path identifier for IPv4 NLRI.....	611
Figure 41: Fully meshed BGP configuration.....	616
Figure 42: BGP configuration with route reflectors.....	617
Figure 43: Route reflector next-hop-self for VPN IPv4 routes over IPv4 labeled routes.....	623
Figure 44: Example of a BGP-LS network.....	628

---

Figure 45: BGP configuration and implementation flow.....	634
Figure 46: Route reflection network diagram example.....	638
Figure 47: RIP packet format.....	803
Figure 48: RIPv1 packet format.....	803
Figure 49: RIPv2 packet format.....	804
Figure 50: RIP configuration and implementation flow.....	805

# 1 Preface

This guide describes routing protocols supported by the 7705 SAR and provides configuration and implementation examples.

This guide is organized into functional chapters and provides concepts and descriptions of the implementation flow, as well as Command Line Interface (CLI) syntax and command usage.



**Note:** This manual generically covers Release 24.x content and may contain some content that will be released in later maintenance loads. Please see the 7705 SAR 24.x.Rx Software Release Notes, part number 3HE20411000xTQZZA, for information about features supported in each load of the Release 24.x software.



**Note:** As of Release 23.4, software support for the following hardware has been deprecated:

- 8-port Ethernet Adapter card, version 2 (a8-ethv2) (3HE02776)
- 12-port Serial Data Interface card, version 1 (a12-sdi) (3HE03391)
- 7705 SAR-W (3HE07349)

These components are no longer recognized in the release.

If information about any of the above components is required, please see the applicable installation guides in Release 22.10.

## 1.1 Audience

This guide is intended for network administrators who are responsible for configuring the 7705 SAR routers. It is assumed that the network administrators have an understanding of networking principles and configurations. Concepts described in this guide include the following:

- IP multicast
- interior gateway protocols (IGP)
- Open Shortest Path First (OSPF) routing protocol
- Intermediate system to Intermediate system (IS-IS) routing protocol
- traffic engineering extensions to IGP
- constrained shortest path first (CSPF)
- Border Gateway Protocols (BGP)
- Routing Information Protocol (RIP)

## 1.2 Technical support

If you purchased a service agreement for your 7705 SAR router and related products from a distributor or authorized reseller, contact the technical support staff for that distributor or reseller for assistance. If you



purchased a Nokia service agreement, follow this link to contact a Nokia support representative and to access product manuals and documentation updates:

[Product Support Portal](#)

## 2 7705 SAR routing configuration process

The 7705 SAR router can function as an LSR (label switch router), allowing it to be used in more complex networks; for example:

- tier-2 aggregation (aggregator of aggregator sites) – traffic is aggregated from other tier-3 7705 SAR nodes (aggregated small cell sites), and this traffic, along with local traffic, is switched to tier-1 7750 SR nodes
- ring-based configurations – multiple tier-3/tier-2 7705 SAR nodes are linked via a ring and a 7750 SR tier-2/tier-1 node, which acts as a gateway from the ring to a higher level or directly to the MTSO



**Note:** For information about the 7705 SAR as an LSR, see the 7705 SAR MPLS Guide.

To switch traffic from one router to another in the network, the 7705 SAR must support IP forwarding. To support these larger and more complex topologies, dynamic routing protocols are provided. The 7705 SAR supports OSPF, IS-IS, BGP, and RIP as dynamic routing protocols.

The following table lists the tasks that are required to configure multicast, OSPF, IS-IS, BGP, and RIP.

This guide is presented in an overall logical configuration flow. Each section describes a software area and provides CLI syntax and command usage to configure parameters for a functional area.

*Table 1: Configuration process*

Area	Task/description	Chapter
Protocol configuration	Configure multicast	<a href="#">IP multicast</a>
	Configure OSPF	<a href="#">OSPF</a>
	Configure IS-IS	<a href="#">IS-IS</a>
	Configure BGP	<a href="#">BGP</a>
	Configure RIP	<a href="#">RIP</a>
Reference	List of security and telecom standards, supported protocols, and proprietary MIBs	<a href="#">Supported standards and protocols</a>

## 3 IP multicast

This chapter provides information about multicast for IPv4 and IPv6, including Internet Group Management Protocol (IGMP), Multicast Listener Discovery (MLD), Protocol Independent Multicast source-specific multicast (PIM-SSM), Protocol Independent Multicast sparse mode (PIM-SM), and Multicast Source Discovery Protocol (MSDP).

Topics in this chapter include:

- [Overview of IP multicast](#)
- [IGMP](#)
- [MLD](#)
- [PIM](#)
- [IPv6 PIM models](#)
- [IP multicast debugging tools](#)
- [MSDP](#)
- [Inter-AS non-segmented mLDP](#)
- [Hashing for inter-AS](#)
- [Hashing at the ASBR](#)
- [Unicast and multicast address translation](#)
- [IP multicast configuration process overview](#)
- [Configuration notes](#)
- [Configuring IP multicast parameters with CLI](#)
- [IP multicast command reference](#)

### 3.1 Overview of IP multicast

IP multicast is a method of sending a single stream of traffic (or a single copy of data) to multiple recipients. IP multicast provides an effective method of one-to-many and many-to-many communication.

In the case of unicast delivery, IP packets are sent from a single source to a single host receiver. The source inserts the address of the target receiver in the IP header destination field of an IP datagram, and intermediate routers (if present) forward the datagram toward the target in accordance with their respective routing tables.

However, some applications, such as audio or video streaming broadcasts, require the delivery of individual IP packets to multiple destinations. In such applications, IP multicast is used to distribute datagrams from one or more source hosts to a set of receivers that may be distributed over different (sub) networks.

Multicast sources can send a single copy of data using a single address for the entire group of recipients. The routers between the source and recipients route the data using the group address route. Multicast packets are delivered to a multicast group. A multicast group specifies a set of recipients who are

interested in a particular data stream and is represented by an IP address from a specified range. Data addressed to the IP address is forwarded to the members of the group. A source host sends data to a multicast group by specifying the multicast group address in the datagram's destination IP address. A source does not have to register to a rendezvous point (RP) in order to send data to a group nor do they need to be a member of the group.

Routers and Layer 3 switches use the Internet Group Management Protocol (IGMP) to manage group membership for IPv4 multicast, and Multicast Listener Discovery (MLD) to manage group membership for IPv6 multicast. When a host receiver wants to receive one or more multicast sessions, it signals its local router by sending a join message to each multicast group it wants to join. When a host wants to leave a multicast group, it sends a Leave message. The local router forwards its group membership information to the core routers to inform the core routers about which multicast flows are needed.

To extend multicast from the receivers' local router to the Internet, the 7705 SAR uses Protocol Independent Multicast (PIM), which employs both unicast and multicast routing tables to keep track of route information. As more routers in the Internet become multicast-capable, using both unicast and multicast routing tables becomes more and more important.

The 7705 SAR also uses the Multicast Source Discovery Protocol (MSDP) as a mechanism to connect multiple IPv4 PIM-SM domains together. Each PIM-SM domain uses its own independent RP and does not have to depend on RPs in other domains.

To summarize, host receivers connect to a local router (7705 SAR) via IGMP or MLD access or network interfaces. The 7705 SAR connects to the network—and eventually to the multicast source device at the far end—via PIM network interfaces. At the multicast source end, the 7705 SAR connects to the source via a PIM access or network interface.

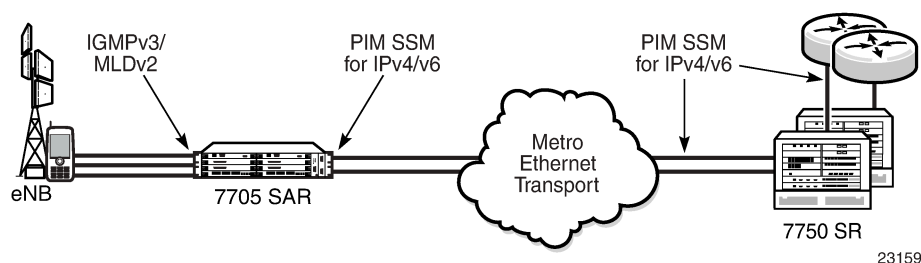
### 3.1.1 Multicast in IP-VPN networks

Multicast can be deployed as part of IP-VPN networks using VPRN. For details, see the "Multicast VPN (MVPN)" section in the 7705 SAR Services Guide.

### 3.1.2 Mobile backhaul IP multicast example

A typical mobile backhaul infrastructure designed for Multimedia Broadcast Multicast Service (MBMS) is shown in the following figure.

Figure 1: IP multicast for MBMS



The 7705 SAR listens for IGMP and MLD receiver requests from the eNB and relays the requested group information back to the requester in one of two ways:

- via local replication, if the stream for the group is already available (that is, one or more receivers have already joined the group)
- via first relaying the request to the upstream router and then replicating the stream to the new receiver when the stream is available

Figure 1: IP multicast for MBMS illustrates this as follows:

- The 7705 SAR listens to IGMPv3 on an eNB IPv4 interface or to MLDv2 on an eNB IPv6 interface.
- The 7705 SAR uses PIM-SSM to send multicast traffic upstream and communicate with the 7750 SR at the MTSO. Similarly, the 7750 SR runs PIM-SSM toward the 7705 SAR.
- The 7750 SR can then run a wide variety of different multicast protocols (such as point-to-multipoint LSPs, and multicast IP-VPN) toward the network core where the source (video head end) is located.

### 3.1.3 Multicast models (ASM and SSM)

Any-source multicast (ASM) provides network layer support for many-to-many delivery. Source-specific multicast (SSM) supports one-to-many delivery.

This section provides information about the following topics:

- [ASM](#)
- [SSM](#)

#### 3.1.3.1 ASM

ASM is the IP multicast service model defined in RFC 1112, *Host extensions for IP Multicasting*. An IP datagram is transmitted to a host group, which is a set of zero or more end-hosts identified by a single IP destination address (224.0.0.0 through 239.255.255.255 for IPv4). End-hosts can join and leave the group at any time and there is no restriction on their location or number. This model supports multicast groups with an arbitrary number of senders. Any end-host can transmit to a host group even if it is not a member of that group.

The ASM service model identifies a group by a (\*, G) pair, where "\*" (star) represents one or more sources.

#### 3.1.3.2 SSM

The SSM service model defines a channel identified by an (S,G) pair, where S is a source address and G is an SSM destination address. In contrast to the ASM model, SSM only provides network-layer support for one-to-many delivery.

The SSM service model attempts to alleviate the following deployment problems that ASM has presented:

- address allocation – SSM defines channels on a per-source basis. For example, the channel (S1,G) is distinct from the channel (S2,G), where S1 and S2 are source addresses. This avoids the problem of global allocation of SSM destination addresses and makes each source independently responsible for resolving address collisions for the various channels it creates.
- access control – SSM provides an efficient solution to the access control problem. When a receiver subscribes to an (S,G) channel, it receives data sent only by the source, S. In contrast, any host can transmit to an ASM host group. At the same time, when a sender picks a channel (S,G) to transmit on, it is automatically ensured that no other sender will be transmitting on the same channel (except in the

case of malicious acts such as address spoofing). This makes it harder to spam an SSM channel than it is to spam an ASM multicast group.

- handling of well-known sources – SSM requires only source-based forwarding trees. This eliminates the need for a shared tree infrastructure. Thus the complexity of the multicast routing infrastructure for SSM is low, making it viable for immediate deployment.

### 3.1.4 IGMP snooping and MLD snooping for VPLS and routed VPLS

The 7705 SAR supports IGMP snooping and MLD snooping for VPLS and routed VPLS (r-VPLS) services. IGMP and MLD snooping is enabled or disabled at the VPLS and r-VPLS service level. Further configurations are available at that level, as well as at the SAP and SDP (spoke and mesh) level of the service.

For details on IGMP and MLD snooping, see the “Multicast for VPLS and Routed VPLS (IGMP and MLD Snooping)” section in the 7705 SAR Services Guide.

### 3.1.5 Multicast over Layer 3 spoke SDP interfaces

The 7705 SAR supports PIM on Layer 3 spoke SDP interfaces. PIM-SM and PIM-SSM are supported for IPv4 in VPRN and IES. PIM-SSM is supported for IPv6 in IES.

A Layer 3 spoke SDP interface can be configured in the same way existing interfaces to be part of PIM IPv4 or PIM IPv6, which allows the interface to be used for multicast signaling and to transport multicast PDUs. GRE, MPLS, LDP, and SR transport tunnels are supported.

When signaling, PIM is tunneled through the Layer 3 spoke SDP interface multihop. Multicast PDUs are tunneled in the reverse direction through the Layer 3 spoke SDP interface. In both cases, packets are encapsulated with the Layer 3 spoke SDP header.

For more information about PIM functionality, see [PIM](#).

## 3.2 IGMP

Internet Group Management Protocol (IGMP) enables multicast applications over native IPv4 networks. This section contains information about the following topics:

- [IGMP overview](#)
- [IGMP versions and interoperability requirements](#)
- [IGMP version transition](#)
- [Query messages](#)
- [Source-specific multicast groups \(IPv4\)](#)

### 3.2.1 IGMP overview

Internet Group Management Protocol (IGMP) is used by IPv4 hosts and routers to report their IP multicast group memberships to neighboring multicast routers. A multicast router keeps a list of multicast group memberships for each attached network, and a timer for each membership.

Multicast group memberships include at least one member of a multicast group on an attached network. In each of its attached networks, a multicast router can assume one of two roles, querier or non-querier. There is normally only one querier per physical network. The querier is the router elected as the router that issues queries for all routers on a LAN segment. Non-queriers listen for reports.

The querier issues two types of queries, a general query and a group-specific query. General queries are issued to solicit membership information with regard to any multicast group. Group-specific queries are issued when a router receives a Leave message from the node it perceives as being the last remaining group member on that network segment. See [Query messages](#) for more information.

SSM translation allows an IGMPv1 or IGMPv2 device to join an SSM multicast network through the router that provides such a translation capability. SSM translation can be done at the node (IGMP protocol) level, and at the interface level, which offers the ability to have the same (\*,G) mapped to two different (S,G)s on two different interfaces to provide flexibility. Because PIM-SSM does not support (\*,G), SSM translation is required to support IGMPv1 and IGMPv2.

Hosts wanting to receive a multicast session issue a multicast group membership report. These reports must be sent to all multicast-enabled routers.

### 3.2.2 IGMP versions and interoperability requirements

If routers run different versions of IGMP, they will negotiate to run the lowest common version of IGMP that is supported on their subnet and operate in that version. The 7705 SAR supports three versions of IGMP:

- version 1 – specified in RFC 1112, *Host extensions for IP Multicasting*, IGMPv1 was the first widely deployed version and the first version to become an Internet standard
- version 2 – specified in RFC 2236, *Internet Group Management Protocol*, IGMPv2 added support for "low leave latency"; that is, a reduction in the time it takes for a multicast router to learn that there are no longer any members of a particular group present on an attached network
- version 3 – specified in RFC 3376, *Internet Group Management Protocol*, IGMPv3 added support for source filtering; that is, the ability for a system to report interest in receiving packets only from specific source addresses, as required to support Source-Specific Multicast or from all but specific source addresses, sent to a particular multicast address (see [Multicast models \(ASM and SSM\)](#))

IGMPv3 must keep track of each group's state for each attached network. The group state consists of a filter-mode, a list of sources, and various timers. For each attached network running IGMP, a multicast router records the required reception state for that network.

### 3.2.3 IGMP version transition

Nokia 7705 SAR routers are capable of interoperating with routers and hosts running IGMPv1, IGMPv2, or IGMPv3. RFC 5186, *Internet Group Management Protocol version 3 (IGMPv3)/Multicast Listener Discovery version 2 (MLDv2) and Multicast Routing Protocol Interaction* explores some of the interoperability issues and how they affect the various routing protocols.

IGMPv3 specifies that, if at any time a router receives an older IGMP version query message on an interface, it must immediately switch to a mode that is compatible with that earlier version. Because the previous versions of IGMP are source-aware, should this occur and the interface switch to version 1 or version 2 compatibility mode, any previously learned group memberships with specific sources (learned via the IGMPv3 specific INCLUDE or EXCLUDE mechanisms) must be converted to non-source-specific group memberships. The routing protocol will then treat this as if there is no EXCLUDE definition present.

### 3.2.4 Query messages

The IGMP query source address is configurable at two hierarchical levels. It can be configured globally at each router instance IGMP level and can be configured individually at the group interface level. The group interface level overrides the source IP address configured at the router instance level.

By default, subscribers with IGMP policies send IGMP queries with an all-zero source IP address (0.0.0.0). However, some systems only accept and process IGMP query messages with non-zero source IP addresses. The query messages feature allows the Broadband Network Gateway (BNG) to interoperate with such systems.

### 3.2.5 Source-specific multicast groups (IPv4)

IGMPv3 allows a receiver to join a group and specify that it only wants to receive traffic for a multicast group if that traffic comes from a particular source. If a receiver does this, and no other receiver on the LAN requires all the traffic for the group, the designated router (DR) can omit performing a (\*,G) join to set up the shared tree, and instead issue a source-specific (S,G) join only.

The range of multicast addresses from 232.0.0.0 to 232.255.255.255 is currently set aside for source-specific multicast in IPv4. For groups in this range, receivers should only issue source-specific IGMPv3 joins. If a PIM router receives a non-source-specific join message for a group in this range, it should ignore it.

A 7705 SAR PIM router must silently ignore a received (\*,G) PIM join message when "G" is a multicast group address from the multicast address group range that has been explicitly configured for SSM. This occurrence should generate an event. If configured, the IGMPv2 request can be translated into IGMPv3. The 7705 SAR allows for the conversion of an IGMPv2 (\*,G) request into a IGMPv3 (S,G) request based on manual entries. A maximum of 32 SSM ranges is supported.

IGMPv3 also allows a receiver to join a group and specify that it only wants to receive traffic for a group if that traffic does not come from a specific source or sources. In this case, the designated router (DR) will perform a (\*,G) join as normal but can combine this with a prune for each of the sources the receiver does not want to receive.

## 3.3 MLD

Multicast Listener Discovery (MLD) enables multicast applications over native IPv6 networks. This section contains information about the following topics:

- [MLD overview](#)
- [MLDv1](#)
- [MLDv2](#)

### 3.3.1 MLD overview

MLD is the IPv6 version of IGMP. The purpose of MLD is to allow each IPv6 router to discover the presence of multicast listeners on its directly attached links, and to discover specifically which multicast groups are of interest to those neighboring nodes.



MLD is a sub-protocol of ICMPv6. MLD message types are a subset of the set of ICMPv6 messages, and MLD messages are identified in IPv6 packets by a preceding Next Header value of 58. All MLD messages are sent with a link-local IPv6 source address, a Hop Limit of 1, and an IPv6 Router Alert option in the Hop-by-Hop Options header.

### 3.3.2 MLDv1

Similar to IGMPv2, MLDv1 reports include only the multicast group addresses that listeners are interested in, and do not include the source addresses. In order to work with the PIM-SSM model, an SSM translation function similar to that used for IGMPv1 and IGMPv2 is required when MLDv1 is used.

SSM translation allows an MLDv1 device to join an SSM multicast network through the router that provides such a translation capability. SSM translation can be done at the node (MLD protocol) level, and at the interface level, which offers the ability to have the same (\*,G) mapped to two different (S,G)s on two different interfaces to provide flexibility. Since PIM-SSM does not support (\*,G), SSM translation is required to support MLDv1.

### 3.3.3 MLDv2

MLDv2 is backwards-compatible with MLDv1 and adds the ability for a node to report interest in listening to packets with a particular multicast group only from specific source addresses or from all sources except for specific source addresses.

## 3.4 PIM

The 7705 SAR supports PIM-SM according to RFC 4601, *Protocol Independent Multicast - Sparse Mode (PIM-SM): Protocol Specification (Revised)*, and PIM-SSM according to RFC 4607, *Source-Specific Multicast for IP*, as described in this section.

For information about PIM-SSM support for IPv4 and IPv6, see [Source-specific multicast groups \(IPv4\)](#) and [IPv6 PIM models](#).

This section contains information about the following topics:

- [PIM-SM overview](#)
- [PIM-SM functions](#)
- [Encapsulating data packets in the register tunnel](#)
- [PIM bootstrap router mechanism](#)
- [PIM-SM routing policies](#)
- [Reverse path forwarding checks](#)
- [Anycast RP for PIM-SM](#)
- [Multicast-only fast reroute \(MoFRR\)](#)
- [Automatic discovery of group-to-RP mappings \(auto-RP\)](#)

### 3.4.1 PIM-SM overview

PIM-SM leverages the unicast routing protocols that are used to create the unicast routing table: OSPF, IS-IS, BGP, and static routes. Because PIM uses this unicast routing information to perform the multicast forwarding function, it is effectively IP protocol-independent. Unlike the distance vector multicast routing protocol (DVMRP), PIM does not send multicast routing table updates to its neighbors.

PIM-SM uses the unicast routing table to perform the reverse path forwarding (RPF) check function instead of building up a completely independent multicast routing table.

PIM-SM only forwards data to network segments with active receivers that have explicitly requested the multicast group. Initially, PIM-SM in the ASM model uses a shared tree to distribute information about active sources. Depending on the configuration options, the traffic can remain on the shared tree or switch over to an optimized source distribution tree. As multicast traffic starts to flow down the shared tree, routers along the path determine if there is a better path to the source. If a more direct path exists, the router closest to the receiver sends a join message toward the source and reroutes the traffic along this path.

PIM-SM relies on an underlying topology-gathering protocol to populate a routing table with routes. This routing table is called the multicast routing information base (MRIB). The routes in this table can be taken directly from the unicast routing table or they can be different and provided by a separate routing protocol such as multicast BGP (MBGP). The primary role of the MRIB in the PIM-SM protocol is to provide the next-hop router along a multicast-capable path to each destination subnet. The MRIB is used to determine the next-hop neighbor to whom any PIM join/prune message is sent. Data flows along the reverse path of the join messages. Therefore, in contrast to the unicast RIB that specifies the next hop that a data packet would take to get to a subnet, the MRIB gives reverse-path information and indicates the path that a multicast data packet would take from its origin subnet to the router that has the MRIB.

**Note:**

- For proper functioning of the PIM protocol, multicast data packets must be received by the CSM CPU. Therefore, CSM filters and management access filters must be configured to allow forwarding of multicast data packets. For details on CSM filters and management access filters, see the "Security" chapter in the 7705 SAR System Management Guide.
- Although the Control and Switching module on the 7705 SAR is called a CSM, the CSM filters are referred to as CPM filters in the CLI in order to maintain consistency with other SR routers.

### 3.4.2 PIM-SM functions

PIM-SM functions in three phases:

- [Phase one](#)
- [Phase two](#)
- [Phase three](#)

#### 3.4.2.1 Phase one

In this phase, a multicast receiver expresses its interest in receiving traffic destined for a multicast group. Typically it does this using IGMP or MLD, but other mechanisms might also serve this purpose. One of the receiver's local routers is elected as the designated router (DR) for that subnet. When the expression of interest is received, the DR sends a PIM join message toward the RP for that multicast group. This

join message is known as a (\*,G) join because it joins group G for all sources to that group. The (\*,G) join travels hop-by-hop toward the RP for the group, and in each router it passes through, the multicast tree state for group G is instantiated. Eventually, the (\*,G) join either reaches the RP or reaches a router that already has the (\*,G) join state for that group. When many receivers join the group, their join messages converge on the RP and form a distribution tree for group G that is rooted at the RP. The distribution tree is called the RP tree or the shared tree (because it is shared by all sources sending to that group). Join messages are re-sent periodically as long as the receiver remains in the group. When all receivers on a leaf network leave the group, the DR will send a PIM (\*,G) prune message toward the RP for that multicast group. However, if the prune message is not sent for any reason, the state will eventually time out.

A multicast data sender starts sending data destined for a multicast group. The sender's local router (the DR) takes these data packets, unicast-encapsulates them, and sends them directly to the RP. The RP receives these encapsulated data packets, removes the encapsulation, and forwards them to the shared tree. The packets then follow the (\*,G) multicast tree state in the routers on the RP tree, are replicated wherever the RP tree branches, and eventually reach all the receivers for that multicast group. The process of encapsulating data packets to the RP is called registering, and the encapsulation packets are known as PIM register packets.

At the end of phase one, multicast traffic is flowing encapsulated to the RP, and then natively over the RP tree to the multicast receivers.

### 3.4.2.2 Phase two

In this phase, register-encapsulation of data packets is performed. However, register-encapsulation of data packets is inefficient for the following reasons:

- Encapsulation and de-encapsulation can be resource-intensive operations for a router to perform depending on whether the router has appropriate hardware for the tasks.
- Traveling to the RP and then back down the shared tree can cause the packets to travel a relatively long distance to reach receivers that are close to the sender. For some applications, increased latency is unwanted.

Although register-encapsulation can continue indefinitely, for the reasons above, the RP will normally switch to native forwarding. To do this, when the RP receives a register-encapsulated data packet from source S on group G, it will normally initiate an (S,G) source-specific join toward S. This join message travels hop-by-hop toward S, instantiating an (S,G) multicast tree state in the routers along the path. The (S,G) multicast tree state is used only to forward packets for group G if those packets come from source S. Eventually, the join message reaches S's subnet or a router that already has the (S,G) multicast tree state, and packets from S start to flow following the (S,G) tree state toward the RP. These data packets can also reach routers with a (\*,G) state along the path toward the RP, and if this occurs, they take a shortcut to the RP tree at this point.

While the RP is in the process of joining the source-specific tree for S, the data packets continue being encapsulated to the RP. When packets from S also start to arrive natively at the RP, the RP receives two copies of each of these packets. At this point, the RP starts to discard the encapsulated copy of these packets and sends a register-stop message back to S's DR to prevent the DR from unnecessarily encapsulating the packets. At the end of phase two, traffic is flowing natively from S along a source-specific tree to the RP and from there along the shared tree to the receivers. Where the two trees intersect, traffic can transfer from the shared RP tree to the shorter source tree.



**Note:** A sender can start sending before or after a receiver joins the group, and therefore phase two may occur before the shared tree to the receiver is built.

### 3.4.2.3 Phase three

In this phase, the RP joins back toward the source using the shortest path tree (SPT). Although having the RP join back toward the source removes the encapsulation overhead, it does not completely optimize the forwarding paths. For many receivers, the route via the RP can involve a significant detour when compared with the shortest path from the source to the receiver.

To obtain lower latencies, a router on the receiver's LAN, typically the DR, may optionally initiate a transfer from the shared tree to a source-specific SPT. To do this, it issues an (S,G) join toward S. This instantiates the (S,G) state in the routers along the path to S. Eventually, this join either reaches S's subnet or reaches a router that already has the (S,G) state. When this happens, data packets from S start to flow following the (S,G) state until they reach the receiver.

At this point, the receiver (or a router upstream of the receiver) is receiving two copies of the data—one from the SPT and one from the RP tree. When the first traffic starts to arrive from the SPT, the DR or upstream router starts to drop the packets for G from S that arrive via the RP tree. In addition, it sends an (S,G) prune message toward the RP. The prune message travels hop-by-hop, instantiating an (S,G) state along the path toward the RP indicating that traffic from S for G should not be forwarded in this direction. The prune message is propagated until it reaches the RP or a router that still needs the traffic from S for other receivers.

By now, the receiver is receiving traffic from S along the SPT between the receiver and S. In addition, the RP is receiving the traffic from S, but this traffic is no longer reaching the receiver along the RP tree. As far as the receiver is concerned, this is the final distribution tree.

### 3.4.3 Encapsulating data packets in the register tunnel

Conceptually, the register tunnel is an interface with a smaller MTU than the underlying IP interface toward the RP. IP fragmentation on packets forwarded on the register tunnel is performed based on this smaller MTU. The encapsulating DR can perform path-MTU discovery to the RP to determine the effective MTU of the tunnel. This smaller MTU takes both the outer IP header and the PIM register header overhead into consideration.

### 3.4.4 PIM bootstrap router mechanism

For proper operation, every PIM-SM router within a PIM domain must be able to map a particular global-scope multicast group address to the same RP. If this is not possible, black holes can appear (this is where some receivers in the domain cannot receive some groups). A domain in this context is a contiguous set of routers that all implement PIM and are configured to operate within a common boundary.

The bootstrap router (BSR) mechanism provides a way in which viable group-to-RP mappings can be created and distributed to all the PIM-SM routers in a domain. Each candidate BSR originates bootstrap messages (BSMs). Every BSM contains a BSR priority field. Routers within the domain flood the BSMs throughout the domain. A candidate BSR that hears about a higher-priority candidate BSR suppresses sending more BSMs for a period of time. The single remaining candidate BSR becomes the elected BSR and its BSMs inform the other routers in the domain that it is the elected BSR.

The PIM bootstrap routing mechanism is adaptive, meaning that if an RP becomes unreachable, the event will be detected and the mapping tables will be modified so that the unreachable RP is no longer used and the new tables are rapidly distributed throughout the domain.

### 3.4.5 PIM-SM routing policies

Multicast traffic can be restricted from certain source addresses by creating routing policies. Join messages can be filtered using import filters. PIM join policies can be used to reduce denial of service attacks and subsequent PIM state explosion in the router and to remove unwanted multicast streams at the edge of the network before they are carried across the core. Route policies are created in the **config>router>policy-options** context. Join and register route policy match criteria for PIM-SM can specify the following:

- router interfaces specified by name or IP address
- neighbor address (the source address in the IP header of the join and prune message)
- multicast group address embedded in the join and prune message
- multicast source address embedded in the join and prune message

Join policies can be used to filter PIM join messages so that no (\*,G) or (S,G) state is created on the router. The following table describes the match conditions.

*Table 2: Join filter policy match conditions*

Match condition	Matches:
Interface	The router interface by name
Neighbor	The neighbor source address in the IP header
Group address	The multicast group address in the join/prune message
Source address	The source address in the join/prune message

PIM register messages are sent by the first-hop designated router that has a direct connection to the source. This serves a dual purpose:

- notifies the RP that a source has active data for the group
- delivers the multicast stream in register encapsulation to the RP and its potential receivers. If no routers have joined the group at the RP, the RP ignores the register requests.

In an environment where the sources to particular multicast groups are always known, register filters can be applied at the RP to prevent any unwanted sources from transmitting a multicast stream. These filters can also be applied at the edge so that register data does not travel unnecessarily over the network toward the RP. The following table describes the match conditions.

*Table 3: Register filter policy match conditions*

Match condition	Matches:
Interface	The router interface by name
Group address	The multicast group address in the join/prune message
Source address	The source address in the join/prune message

### 3.4.6 Reverse path forwarding checks

Multicast implements a reverse path forwarding (RPF) check. RPF checks the path that multicast packets take between their sources and the destinations to prevent loops. Multicast requires that an incoming interface be the outgoing interface used by unicast routing to reach the source of the multicast packet. RPF forwards a multicast packet only if it is received on an interface that is used by the router to route to the source.

If the forwarding paths are modified due to routing topology changes, any dynamic filters that may have been applied must be re-evaluated. If filters are removed, the associated alarms are also cleared.

### 3.4.7 Anycast RP for PIM-SM

The implementation of anycast rendezvous point (RP) for PIM-SM environments enables fast convergence if a PIM RP router fails by allowing receivers and sources to rendezvous at the closest RP. It allows an arbitrary number of RPs per group in a single shared tree PIM-SM domain. This is particularly important for triple play configurations that choose to distribute multicast traffic using PIM-SM, not SSM. In this case, RP convergence must be fast enough to avoid the loss of multicast streams that could cause loss-of-TV delivery to the end customer.

Anycast RP for PIM-SM environments is supported in the base routing PIM-SM instance of the service router. This feature is also supported in Layer 3 VPRN instances that are configured with PIM.

#### 3.4.7.1 Implementation

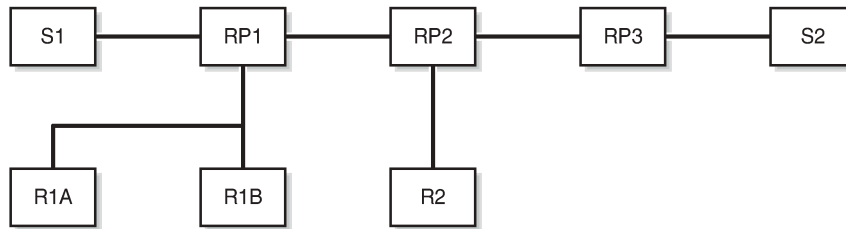
The anycast RP for PIM-SM implementation is defined in RFC 4610, *Anycast-RP Using Protocol Independent Multicast (PIM)*, and is similar to that described in RFC 3446, *Anycast Rendezvous Point (RP) mechanism using Protocol Independent Multicast (PIM) and Multicast Source Discovery Protocol (MSDP)*. The implementation extends the register mechanism in PIM so that anycast RP functionality can be retained without using MSDP. For details, see the "Multicast VPN (MVPN)" section in the 7705 SAR Services Guide.

The mechanism works as follows:

- An IP address is chosen as the RP address. This address is statically configured or distributed using a dynamic protocol to all PIM routers throughout the domain.
- A set of routers in the domain are chosen to act as RPs for this RP address. These routers are called the anycast-RP set.
- Each router in the anycast-RP set is configured with a loopback interface using the RP address.
- Each router in the anycast-RP set also needs a separate IP address to be used for communication between the RPs.
- The RP address, or a prefix that covers the RP address, is injected into the unicast routing system inside the domain.
- Each router in the anycast-RP set is configured with the addresses of all other routers in the anycast-RP set. This must be consistently configured for all RPs in the set.

The following figure shows a scenario where all routers connected, and where R1A, R1B, and R2 are receivers for a group and S1 and S2 send to that group. In the example, RP1, RP2, and RP3 are all assigned the same IP address that is used as the anycast-RP address (RPA).

Figure 2: Anycast RP for PIM-SM implementation



26795



**Note:** The address used for the RP address in the domain (the RPA address) must be different from the addresses used by the anycast-RP routers to communicate with each other.

The following procedure is used when S1 starts sourcing traffic:

1. S1 sends a multicast packet.
2. The DR directly attached to S1 forms a PIM register message to send to the RPA. The unicast routing system delivers the PIM register message to the nearest RP, in this case RP1.
3. RP1 receives the PIM register message, de-encapsulates it, and sends the packet down the shared tree to receivers R1A and R1B.
4. RP1 is configured with the IP addresses of RP2 and RP3. Because the register message did not come from one of the RPs in the anycast-RP set, RP1 assumes the packet came from a DR. If the register message is not addressed to the RPA, an error has occurred and it should be rate-limited logged.
5. RP1 sends a copy of the register message from S1's DR to both RP2 and RP3. RP1 uses its own IP address as the source address for the PIM register message.
6. RP1 may join back to the source tree by triggering an (S1,G) join message toward S1; however, RP1 must create an (S1,G) state.
7. RP2 receives the register message from RP1, de-encapsulates it, and also sends the packet down the shared tree to receiver R2.
8. RP2 sends a register-stop message back to RP1. RP2 may wait to send the register-stop message if it decides to join the source tree. RP2 should wait until it has received data from the source on the source tree before sending the register-stop message. If RP2 decides to wait, the register-stop message will be sent when the next register is received. If RP2 decides not to wait, the register-stop message is sent immediately.
9. RP2 may join back to the source tree by triggering an (S1,G) join message toward S1; however, RP2 must create an (S1,G) state.
10. RP3 receives the register message from RP1 and de-encapsulates it, but since there are no receivers joined for the group, it discards the packet.
11. RP3 sends a register-stop message back to RP1.
12. RP3 creates an (S1,G) state so when a receiver joins after S1 starts sending, RP3 can join quickly to the source tree for S1.
13. RP1 processes the register-stop messages from RP2 and RP3. RP1 may cache—on a per-RP/per-(S,G) basis—the receipt of register-stop messages from the RPs in the anycast-RP set. This option is performed to increase the reliability of register message delivery to each RP. When this option is used,



subsequent register messages received by RP1 are sent only to the RPs in the anycast-RP set that have not previously sent register-stop messages for the (S,G) entry.

14. RP1 sends a register-stop message back to the DR the next time a register message is received from the DR and, when the option in step 13 is in use, if all RPs in the anycast-RP set have returned register-stop messages for a particular (S,G) route.

The procedure for S2 sending follows the same steps as above, but it is RP3 that sends a copy of the register originated by S2's DR to RP1 and RP2. Therefore, this example shows how sources anywhere in the domain, associated with different RPs, can reach all receivers, also associated with different RPs, in the same domain.

### 3.4.8 Multicast-only fast reroute (MoFRR)

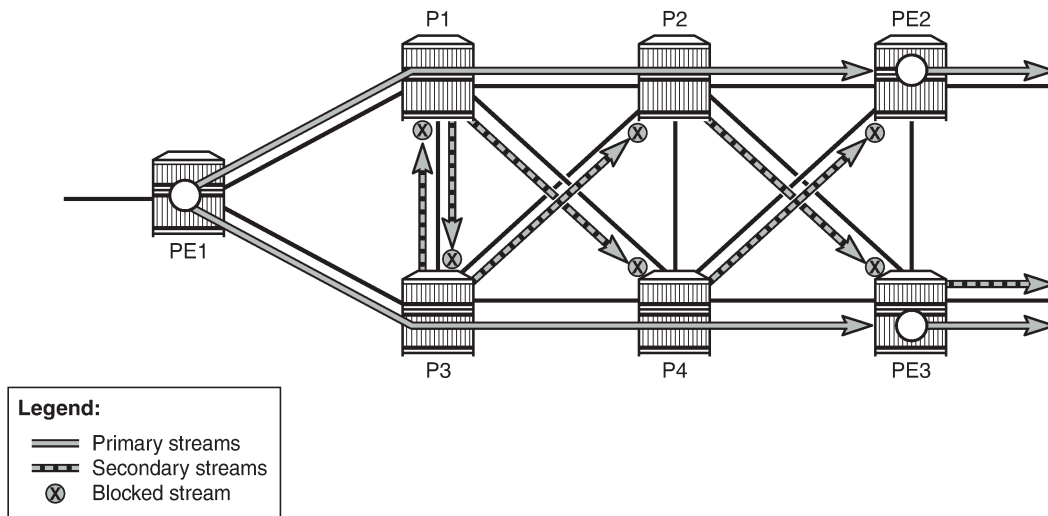
The 7705 SAR supports multicast-only fast reroute (MoFRR) in the context of GRT for mLDP, where the multicast traffic is duplicated on a primary mLDP multicast tree and on a secondary mLDP multicast tree. These are two separate mLDP LSPs, and they are therefore set up separately. The root node transmits multicast PDUs on both active and inactive LSPs. The PDUs are duplicated using the multicast tree and sent through the network to the leaf node on both the active and the inactive LSPs. The leaf listens only to the active LSP and drops PDUs from the secondary, inactive LSP.

The MoFRR functionality relies on detecting failures on the primary path and switching to forwarding the traffic to the standby path. The traffic failure can happen with or without physical links or nodes going down. Various mechanisms for link or node failure detections are supported. However, for best performance and resilience, enable MoFRR on every node in the network and use hop-by-hop BFD for detection of fast link failure or data plane failure on each upstream link. If BFD is not used, PIM adjacency loss or a route change can be used to detect traffic failure.

The following figures illustrate MoFRR with no failure and with a failure. MoFRR is enabled on P1, P2, P3, P4, PE2, and PE3. Primary streams (solid gray lines) are active; one stream is from PE1 to PE2 and another is from PE1 to PE3. Secondary streams (gray-black lines) are blocked (circles with "X" inside). In [Figure 4: MoFRR in failure state](#), PE3 detects a link failure between P4 and PE3, and switches to the standby (secondary) stream from P2.

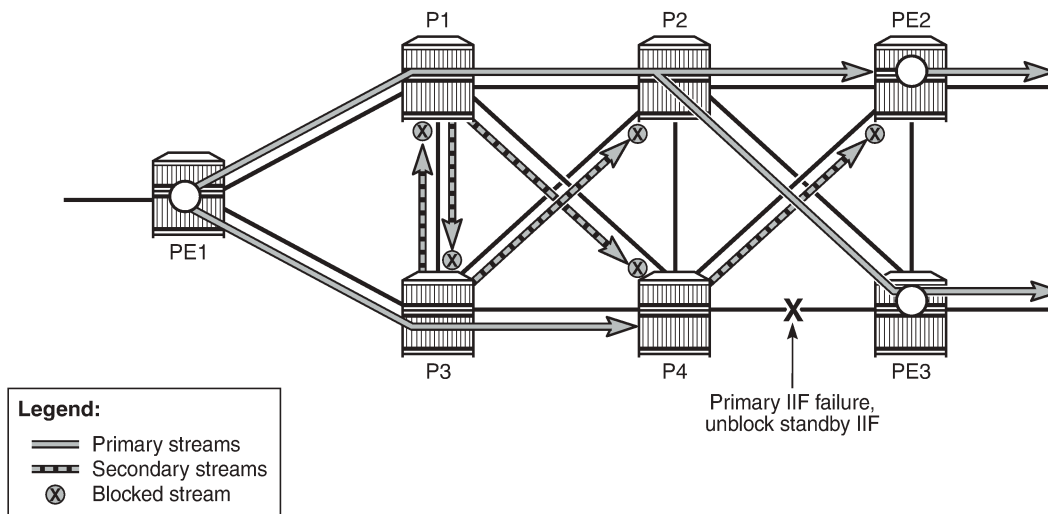


Figure 3: MoFRR in steady state with no failure



25935

Figure 4: MoFRR in failure state



25936

### 3.4.9 Automatic discovery of group-to-RP mappings (auto-RP)

Auto-RP is a proprietary group discovery and mapping mechanism for IPv4 PIM that is described in cisco-ipmulticast/pim-autorp-spec, *Auto-RP: Automatic discovery of Group-to-RP mappings for IP multicast*. The functionality is similar to the IETF standard BSR mechanism that is described in RFC 5059, *Bootstrap Router (BSR) Mechanism for Protocol Independent Multicast (PIM)*, to dynamically learn about the availability of RPs in a network.

When a router is configured as an RP mapping agent with the **pim>rp>auto-rp-discovery** command, it listens to the CISCO-RP-ANNOUNCE (224.0.1.39) group and caches the announced mappings. The RP mapping agent then periodically sends out RP mapping packets to the CISCO-RP-DISCOVERY (224.0.1.40) group. PIM dense mode (PIM-DM) as described in RFC 3973, *Protocol Independent Multicast - Dense Mode (PIM-DM): Protocol Specification (Revised)*, is used for the auto-RP groups to support multihoming and redundancy. The RP mapping agent supports announcing, mapping, and discovery functions; candidate RP functionality is not supported.

Auto-RP is supported for IPv4 in multicast VPNs and in the global routing instance. Either BSR or auto-RP for IPv4 can be configured; the two mechanisms cannot be enabled together. In a multicast VPN, auto-RP cannot be enabled together with sender-only or receiver-only multicast distribution trees (MDTs), or wildcard S-PMSI configurations that could block flooding.

## 3.5 IPv6 PIM models

IPv6 multicast enables multicast applications over native IPv6 networks. There are two service models: any-source multicast (ASM) and source-specific multicast (SSM), which includes PIM-SSM and MLD. SSM does not require source discovery and only supports a single source for a specific multicast stream. As a result, SSM is easier to operate in a large-scale deployment that uses the one-to-many service model.

### 3.5.1 PIM-SSM

The IPv6 address family for the SSM model is supported. OSPFv3 and static routing have extensions to support submission of routes into the IPv6 multicast RTM.

### 3.5.2 PIM-ASM

IPv4 PIM-ASM is supported. All PIM-ASM related functions—such as bootstrap router and RP—support the IPv4 address family.

## 3.6 IP multicast debugging tools

This section describes multicast debugging tools for the 7705 SAR. The debugging tools for multicast consist of three elements, which are accessed from the CLI <global> level:

- [Mtrace](#)
- [Mstat](#)
- [Mrinfo](#)

### 3.6.1 Mtrace

Assessing problems in the distribution of IP multicast traffic can be difficult. The multicast traceroute (mtrace) feature uses a tracing feature implemented in multicast routers that is accessed via an extension to the IGMP protocol. The mtrace feature is used to print the path from the source to a receiver; it does this by passing a trace query hop-by-hop along the reverse path from the receiver to the source. At each

hop, information such as the hop address, routing error conditions, and packet statistics are gathered and returned to the requester.

Data added by each hop includes:

- query arrival time
- incoming interface
- outgoing interface
- previous hop router address
- input packet count
- output packet count
- total packets for this source/group
- routing protocol
- TTL threshold
- forwarding/error code

The information enables the network administrator to determine:

- the flow of the multicast stream
- where multicast flows stop

When the trace response packet reaches the first-hop router (the router that is directly connected to the source's network interface), that router sends the completed response to the response destination (receiver) address specified in the trace query.

If a multicast router along the path does not implement the mtrace feature or if there is an outage, then no response is returned. To solve this problem, the trace query includes a maximum hop count field to limit the number of hops traced before the response is returned. This allows a partial path to be traced.

The reports inserted by each router contain not only the address of the hop, but also the TTL required to forward the packets and flags to indicate routing errors, plus counts of the total number of packets on the incoming and outgoing interfaces and those forwarded for the specified group. Examining the differences in these counts for two separate traces and comparing the output packet counts from one hop with the input packet counts of the next hop allows the calculation of packet rate and packet loss statistics for each hop to isolate congestion problems.

### 3.6.1.1 Finding the last-hop router

The trace query must be sent to the multicast router that is the last hop on the path from the source to the receiver. If the receiver is on the local subnet (as determined by the subnet mask), then the default method is to send the trace query to all-routers.mcast.net (224.0.0.2) with a TTL of 1. Otherwise, the trace query is sent to the group address since the last-hop router will be a member of that group if the receiver is. Therefore, it is necessary to specify a group that the intended receiver has joined. This multicast query is sent with a default TTL of 64, which may not be sufficient for all cases.

When tracing from a multihomed host or router, the default receiver address may not be the desired interface for the path from the source. In that case, the desired interface should be specified explicitly as the receiver.

### 3.6.1.2 Directing the response

By default, mtrace first attempts to trace the full reverse path, unless the number of hops to trace is explicitly set with the hop option. If there is no response within a 3-s timeout interval, a "\*" is displayed and the probing switches to hop-by-hop mode. Trace queries are issued starting with a maximum hop count of one and increasing by one until the full path is traced or no response is received. At each hop, multiple probes are sent. The first attempt is made with the unicast address of the host running mtrace as the destination for the response. Since the unicast route may be blocked, the remainder of attempts request that the response be sent to mtrace.mcast.net (224.0.1.32) with the TTL set to 32 more than what is needed to pass the thresholds seen so far along the path to the receiver. For the last attempts, the TTL is increased by another 32.

Alternatively, the TTL may be set explicitly with the TTL option.

For each attempt, if no response is received within the timeout, a "\*" is displayed. After the specified number of attempts have failed, mtrace will try to query the next-hop router with a DVMRP\_ASK\_NEIGHBORS2 request (as used by the mrinfo feature) to determine the router type.

The output of mtrace is a short listing of the hops in the order they are queried, that is, in the reverse of the order from the source to the receiver. For each hop, a line is displayed showing:

- the hop number (counted negatively to indicate that this is the reverse path)
- the multicast routing protocol
- the threshold required to forward data (to the previous hop in the listing as indicated by the up-arrow character)
- the cumulative delay for the query to reach that hop (valid only if the clocks are synchronized)

The response ends with a line showing the round-trip time which measures the interval from when the query is issued until the response is received, both derived from the local system clock.

Mtrace/mstat packets use special IGMP packets with IGMP type codes of 0x1E and 0x1F.

### 3.6.2 Mstat

The mstat feature adds the capability to show the multicast path in a limited graphic display and indicates drops, duplicates, TTLs, and delays at each node. This information is useful to the network operator because it identifies nodes with high drop and duplicate counts. Duplicate counts are shown as negative drops.

The output of mstat provides a limited pictorial view of the path in the forward direction with data flow indicated by arrows pointing downward and the query path indicated by arrows pointing upward. For each hop, both the entry and exit addresses of the router are shown if different, along with the initial TTL required on the packet in order to be forwarded at this hop and the propagation delay across the hop assuming that the routers at both ends have synchronized clocks. The output consists of two columns, one for the overall multicast packet rate that does not contain lost/sent packets and the other for the (S,G)-specific case. The (S,G) statistics also do not contain lost/sent packets.

### 3.6.3 Mrinfo

The mrinfo feature is a simple mechanism to display the configuration information from the target multicast router. The type of information displayed includes the multicast capabilities of the router, code version,

metrics, TTL thresholds, protocols, and status. This information can be used by network operators, for example, to verify if bidirectional adjacencies exist. Once the specified multicast router responds, the configuration is displayed.

## 3.7 MSDP

Multicast Source Discovery Protocol (MSDP) is a mechanism that allows rendezvous points (RPs) to share information about active sources. When RPs in remote domains hear about the active sources, they can pass on that information to the local receivers and multicast data can be forwarded between the domains. MSDP allows each domain to maintain an independent RP that does not rely on other domains, but it also enables RPs to forward traffic between domains. PIM-SM is used to forward the traffic between the multicast domains.

Using PIM-SM, multicast sources and receivers register with their local RP via the closest multicast router. The RP maintains information about the sources and receivers for any particular group. RPs in other domains do not have any knowledge about sources located in other domains.

MSDP-speaking routers in a PIM-SM domain have an MSDP peering relationship with MSDP peers in another PIM-SM domain. The peering relationship is made up of a TCP connection in which control information is exchanged. Each domain has one or more connections to this virtual topology.

When a PIM-SM RP learns about a new multicast source within its own domain from a standard PIM register mechanism, it encapsulates the first data packet in an MSDP source-active (SA) message and sends it to all MSDP peers.

After an RPF check, the SA message is flooded by each peer to its MSDP peers until the SA message reaches every MSDP router in the interconnected networks. If the receiving MSDP peer is an RP, and the RP has a (\*,G) entry (receiver) for the group, the RP creates a (\*,G) state for the source and joins the shortest path tree for the source. The encapsulated data is de-encapsulated and forwarded down the shared tree of that RP. When the packet is received by the last-hop router of the receiver, the last-hop router can also join the shortest path tree to the source.

The MSDP speaker periodically sends SA messages that include all sources.

This section contains information about the following topics:

- [MSDP and anycast RP](#)
- [MSDP procedure](#)
- [MSDP peer groups](#)
- [MSDP mesh groups](#)
- [MSDP routing policies](#)
- [Auto-RP \(discovery mode only\) in multicast VPN](#)

The 7705 SAR supports MSDP in the base router context and on MVPNs in the VPRN service context. For information about MSDP on MVPNs, see "Multicast Source Discovery Protocol" in the Multicast VPN (MVPN) section of the 7705 SAR Services Guide.

### 3.7.1 MSDP and anycast RP

MSDP is required to provide inter-domain multicast services using any-source Multicast (ASM). Anycast RP for MSDP enables fast convergence when an MSDP PIM RP router fails by allowing receivers and sources to rendezvous at the closest RP.

### 3.7.2 MSDP procedure

When an RP in a PIM-SM domain first learns of a new sender—for example, by PIM register messages—it constructs an SA message and sends it to its MSDP peers. The SA message contains the following fields:

- source address of the data source
- group address the data source sends to
- IP address of the RP



**Note:** An RP that is not a designated router on a shared network does not originate SAs for directly connected sources on that shared network. An RP only originates SAs in response to receiving register messages from the designated router.

Each MSDP peer receives and then forwards the SA message away from the RP address in a peer-RPF flooding fashion. The RPF multicast routing information base (MRIB) is examined to determine which peer toward the originating RP of the SA message is selected. This peer is called an RPF peer. The MSDP peer performs peer-RPF forwarding by comparing the RP address carried in the SA message against the MSDP peer from which the message was received.

If the MSDP peer receives the SA from a non-RPF peer toward the originating RP, it will drop the message. Otherwise, it forwards the message to all its MSDP peers (except the one from which it received the SA message).

When an MSDP peer that is also an RP for its own domain receives a new SA message, it determines if there are any group members within the domain interested in any group described by an (S,G) entry within the SA message. That is, the RP checks for a (\*,G) entry with a non-empty outgoing interface list. This implies that some router in the domain is interested in the group. In this case, the RP triggers an (S,G) join event toward the data source as if a join/prune message was received addressed to the RP. This sets up a branch of the source tree to this domain. Subsequent data packets arrive at the RP by this tree branch and are forwarded down the shared tree inside the domain. If leaf routers choose to join the source tree, they have the option to do so according to existing PIM-SM conventions. If an RP in a domain receives a PIM join message for a new group G, the RP must trigger an (S,G) join event for each active (S,G) for that group in its cache.

This procedure is called flood-and-join because if any RP is not interested in the group, the SA message can be ignored; otherwise, the RPs join a distribution tree.

#### 3.7.2.1 MSDP peering scenarios

The 7705 SAR conforms to *draft-ietf-mboned-msdp-deploy-nn, Multicast Source Discovery Protocol (MSDP) Deployment Scenarios*, which describes how PIM-SM and MP-BGP work together to provide intra- and inter-domain ASM service.

The 7705 SAR supports the following intra-domain MSDP peering deployment options:

- peering between routers configured for both MSDP and MBGP
- MSDP peer is not a BGP peer (or no BGP peer)

The 7705 SAR supports the following inter-domain MSDP peering deployment options:

- peering between PIM border routers (single-hop peering)
- peering between non-border routers (multi-hop peering)
- MSDP peering without BGP
- MSDP peering between mesh groups
- MSDP peering at a multicast exchange

### 3.7.3 MSDP peer groups

MSDP peer groups are typically created when multiple peers have a set of common operational parameters. Group parameters that are not specifically configured are inherited from the global level.

### 3.7.4 MSDP mesh groups

MSDP mesh groups are used to reduce SA flooding primarily in intra-domain configurations. When multiple speakers in an MSDP domain are fully meshed, they can be configured as a mesh group. The originator of the SA message forwards the message to all members of the mesh group; therefore, forwarding the SA message between non-originating members of the mesh group is not necessary.

### 3.7.5 MSDP routing policies

MSDP routing policies allow for filtering of inbound and outbound SA messages. Policies can be configured at different levels:

- global level – applies to all peers
- group level – applies to all peers in a peer group
- neighbor level – applies only to a specified peer

The most specific level is used. If multiple policy names are specified, the policies are evaluated in the order they are specified. The first policy that matches is applied. If no policy is applied, SA messages are passed.

Match conditions include:

- neighbor – the policy matches on a neighbor address that is the source address in the IP header of the SA message
- route filter – the policy matches on a multicast group address embedded in the SA message
- source address filter – the policy matches on a multicast source address embedded in the SA message

### 3.7.6 Auto-RP (discovery mode only) in multicast VPN

Auto-RP is a vendor proprietary protocol used to dynamically learn about the availability of RPs in a network. The auto-RP protocol consists of announcing, mapping, and discovery functions. The 7705 SAR

supports the discovery mode of auto-RP, which includes mapping and forwarding of RP-mapping messages and RP-candidate messages. Discovery mode also includes receiving RP-mapping messages locally in order to learn and maintain the RP-candidate database.

The auto-RP protocol is supported for multicast VPN and in the global routing instance. Either BSR or auto-RP can be configured per routing instance. Both mechanisms cannot be enabled together.

### 3.8 Inter-AS non-segmented mLDP

This feature allows multicast services to use segmented protocols and span them over multiple autonomous systems (ASs) in the same way as unicast services. Because IP VPN or GRT services span multiple IGP areas or multiple ASs, either for a network designed to deal with scale or as a result of commercial acquisitions, operators may require inter-AS VPN (unicast) connectivity. For example, an inter-AS VPN can break the IGP, MPLS, and BGP protocols into access segments and core segments, allowing higher scaling of protocols by segmenting them into their own islands. The 7705 SAR allows for a similar provisioning of multicast services and for spanning these services over multiple IGP areas or multiple ASs.

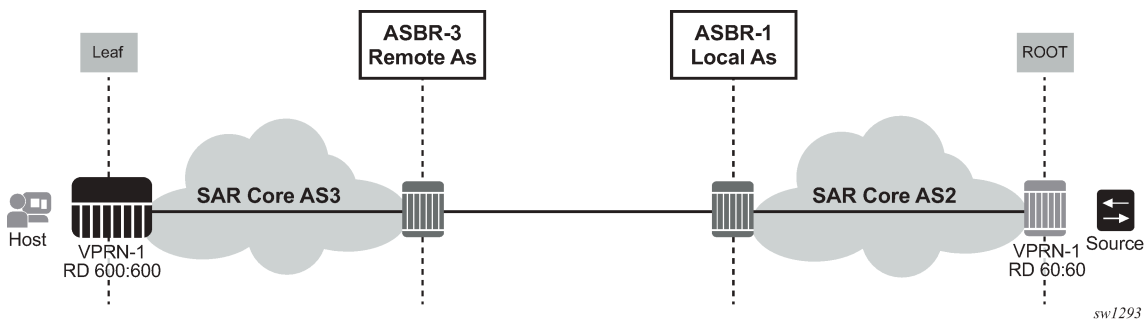
Multicast LDP (mLDP) supports non-segmented mLDP trees for inter-AS solutions that are applicable for NG-MVPN services. See the 7705 SAR Services Guide, "NG-MVPN non-segmented inter-AS solution" for information.

For information about ECMP behavior for inter-AS non-segmented mLDP, see the 7705 SAR MPLS Guide, "ECMP support" under "Inter-AS non-segmented mLDP".

#### 3.8.1 ASBR support of PE functionality

The following figure displays remote and local ASBRs.

Figure 5: Remote and local ASBRs



ASBRs can also act as PE nodes, but the 7705 SAR does not support all PE functionalities in the ASBR node. The following table lists supported PE features on ASBRs.

Table 4: PE features on ASBRs

Inter-AS multicast context	ASBR node	
	Leaf or bud	Root or source
GRT	X	X



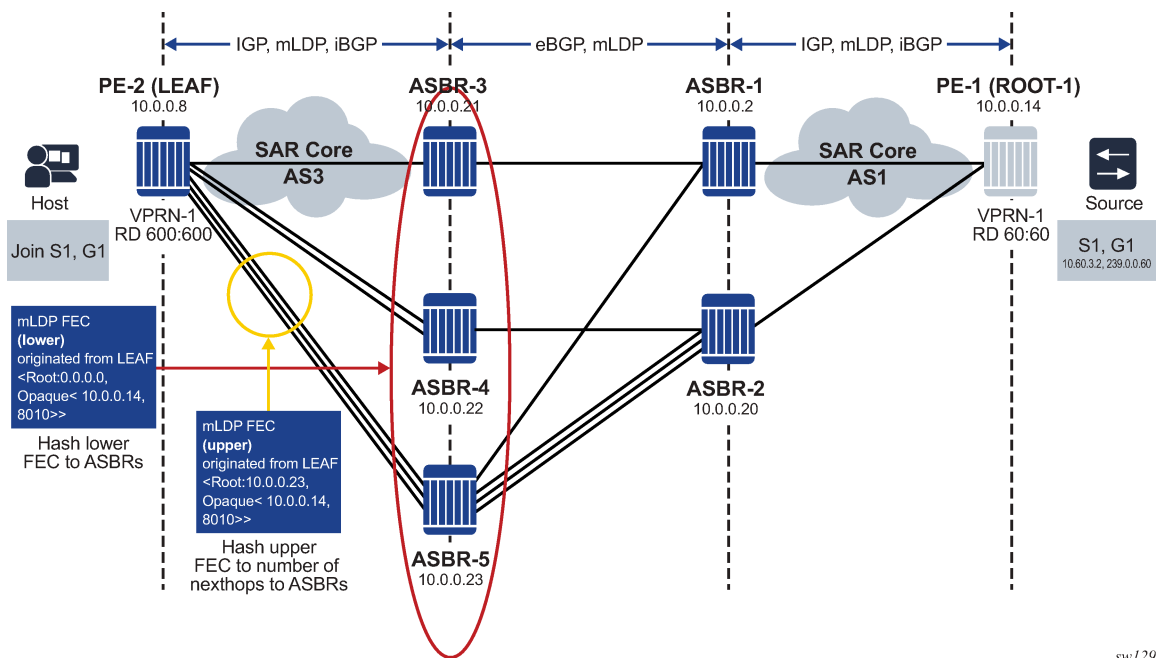
Inter-AS multicast context	ASBR node	
	Leaf or bud	Root or source
VPN	✓	X

### 3.9 Hashing for inter-AS

At each leaf or ASBR, there are two FECs: a lower FEC and an upper FEC. The lower FEC is used for hashing to multiple ASBRs and the upper FEC is used to choose the next hop that connects the leaf node to the ASBR. Hashing is performed based on the opaque value of the FEC. See the 7705 SAR MPLS Guide, "Supported Recursive Opaque Values", for more information.

In the following figure, the leaf generates a lower FEC of <0.0.0.0, opaque <10.0.0.14, 8010>>. The lower FEC opaque <10.0.0.14, 8010> and number of ASBRs (three) is used to decide which ASBR will be used based on hashing. After hashing produces ASBR-5 as the result, the upper FEC of <10.0.0.23, opaque <10.0.0.14, 8010>> is created. This upper FEC is used to resolve the ASBR-5 next hop between the three interfaces that connect the leaf node to ASBR-5.

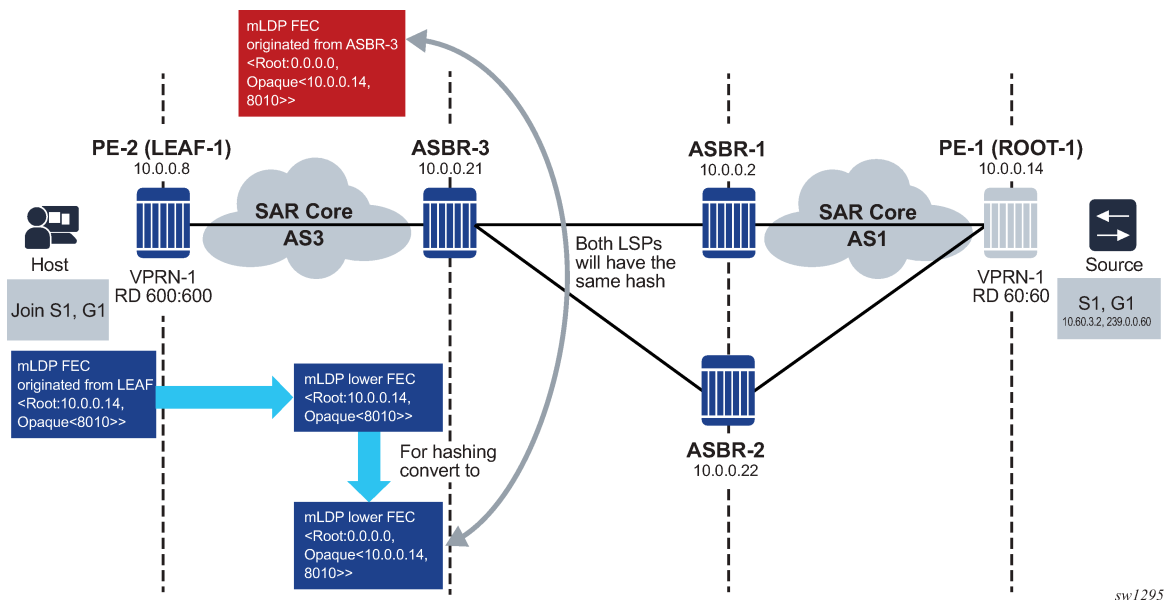
Figure 6: Hashing for inter-AS



### 3.10 Hashing at the ASBR

The following figure illustrates hashing at the ASBR.

Figure 7: Hashing at the ASBR



In the figure, the leaf node will have ROOT-1 in the RTM for inter-AS option C; therefore, the leaf will not generate a recursive type 7 opaque and will only generate a type 1 opaque. When the FEC arrives at ASBR-3, it will have a basic type 1 FEC of <ROOT: 10.0.0.14, opaque <8010>>.

If the ASBR also has a host that will generate an mLDP LSP toward the root, this FEC will look up <ROOT: 0.0.0.0, opaque <10.0.0.14, 8010>>.

Hashing is performed based on the opaque value of the FEC. Refer to the 7705 SAR MPLS Guide, "Supported recursive opaque values" for more information.

The opaque of the leaf node is not the same as the opaque of the ASBR bud node. In this scenario, the two LSPs will generate a different ASBR as the next hop, inefficiently duplicating multicast traffic. In order to prevent this problem, the 7705 SAR converts the opaque type 1 lower FEC, that arrives from the leaf node, into a recursive type 7 FEC, so that the bud FEC generated by the ASBR and the FEC arriving from the leaf node will result in the same upper ASBR.

### 3.11 Unicast and multicast address translation

The 7705 SAR supports unicast-to-multicast address translation and multicast-to-multicast address translation.

For unicast-to-multicast translation, the 7705 SAR translates the destination IP address of the unicast flow to a multicast group.

For multicast-to-multicast translation, the 7705 SAR acts as a host to upstream (S,G)s and performs address translation to the downstream (S,G).

Unicast and multicast address translation is supported on the following adapter cards and platforms:

- on the 7705 SAR-8 Shelf V2 and the 7705 SAR-18:
  - 2-port 10GigE (Ethernet) Adapter card

- 6-port Ethernet 10Gbps Adapter card
- 8-port Gigabit Ethernet Adapter card, version 3
- 10-port 1GigE/1-port 10GigE X-Adapter card, version 2 (supported on the 7705 SAR-18 only)
- 7705 SAR-Ax
- 7705 SAR-H
- 7705 SAR-Hc
- 7705 SAR-Wx
- 7705 SAR-X

### 3.11.1 Unicast-to-multicast address translation

With unicast-to-multicast address translation, unicast packets destined for a local loopback interface on the 7705 SAR are translated to a multicast (S,G).

Unicast-to-multicast translation is supported in the global routing table (GRT) and in VPRNs. Both IPv4 and IPv6 address families are supported for the GRT, while IPv4 addressing on SAP-to-SAP connections is supported for VPRNs.

For the 7705 SAR to perform unicast-to-multicast address translation, the following is required:

- The unicast traffic must be destined for a loopback IP address on the translator router (7705 SAR).
- The multicast source must be a loopback IP address on the 7705 SAR that is also configured under a PIM, IGMP, or MLD interface.
- The 7705 SAR only forwards multicast traffic on the outgoing interfaces that receive the (S,G) join.
- The unicast domain must support resilience functionality such as LFA, ECMP, or LAG.
- All hosts in the multicast domain must join a loopback IP on the 7705 SAR that is doing unicast-to-multicast translation.

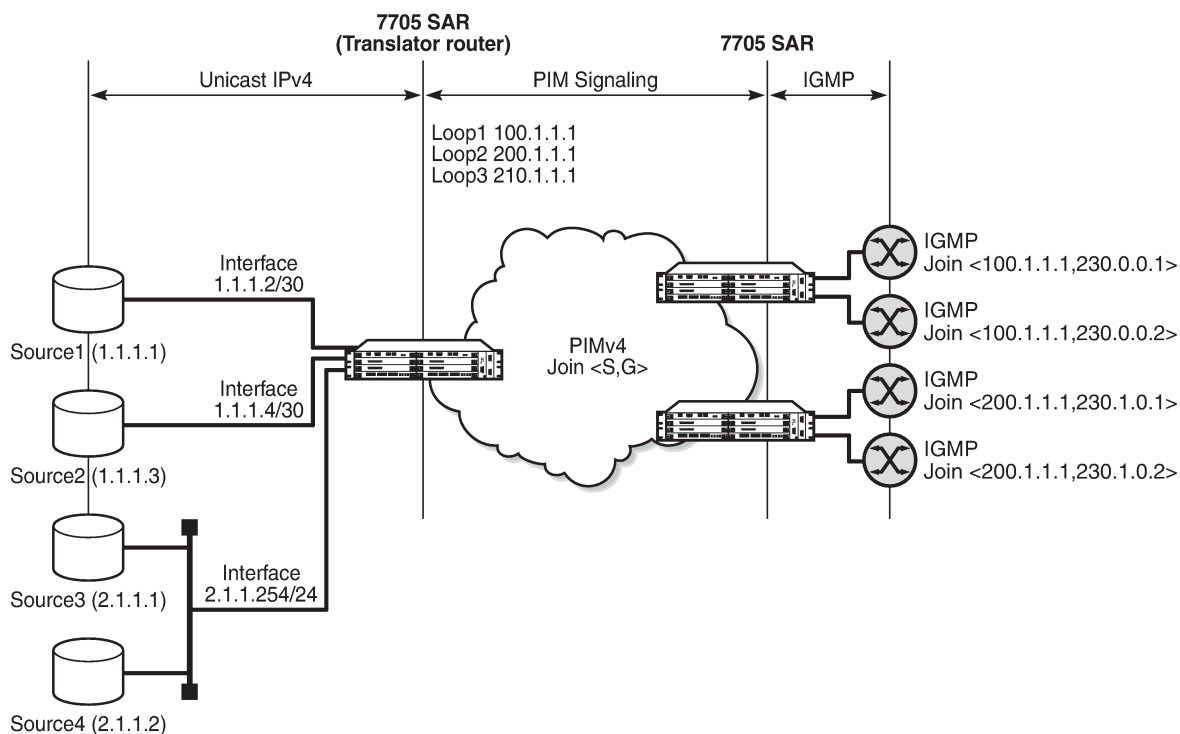


#### Note:

- For IES and VPRN services, the normal operation of unicast-to-multicast translation does not require an ingress IES or VPRN physical interface to be added under the PIM context. However, if separate QoS treatment is required for the unicast traffic that is translated to multicast traffic, the multicast traffic must be mapped to a multicast queue in a SAP ingress QoS policy assigned to the SAP for the IES or VPRN ingress interface. In order for this multicast queue to be created, the physical IES or VPRN interface must also be added under the PIM context.
- To prevent PIM Hello messages from being sent from the IES or VPRN interface back to the unicast domain, the interface should be shut down under PIM.

The following figure shows an example of the 7705 SAR acting as a translator router for unicast-to-multicast address translation.

Figure 8: Unicast-to-multicast translation on the 7705 SAR



36405

In the figure, the host (leaf) nodes in a multicast group are connected to a local router via an interface configured for IGMP or MLD; however, the hosts can also be connected to the translator directly via an IGMP or MLD interface. The local router is connected to the translator router via a PIM interface. To receive a multicast session, the local router must send a PIM join message to the translator router. After translating the traffic from unicast to multicast, the 7705 SAR forwards multicast traffic on the outgoing interfaces that receive the (S,G) join.

The following CLI example shows the configuration to enable multicast translation on three loopback interfaces on the 7705 SAR translator router based on the scenario shown in [Figure 8: Unicast-to-multicast translation on the 7705 SAR](#). The loopback interfaces are the destination for the unicast traffic.

**Example:**

```

config>router# interface loop1
config>router>if# multicast-translation
config>router>if# exit
config>router# interface loop2
config>router>if# multicast-translation
config>router>if# exit
config>router# interface loop3
config>router>if# multicast-translation
config>router>if# exit
    
```

The following CLI example shows the configuration to translate the unicast source addresses to a destination multicast group based on the scenario shown in [Figure 8: Unicast-to-multicast translation on the 7705 SAR](#).

**Example:**

```
config>router# pim
config>router>pim# interface loop1
config>router>pim>if# unicast-to-multicast unicast-start 1.1.1.1 unicast-
end 1.1.1.1 destination 100.1.1.1 to-multicast 230.0.0.1
config>router>pim>if# no shutdown
config>router>pim>if# exit
config>router>pim# interface loop2
config>router>pim>if# unicast-to-multicast unicast-start 1.1.1.3 unicast-
end 1.1.1.3 destination 200.1.1.1 to-multicast 230.0.0.2
config>router>pim>if# no shutdown
config>router>pim>if# exit
config>router>pim# interface loop2
config>router>pim>if# unicast-to-multicast unicast-start 2.1.1.1 unicast-
end 2.1.1.2 destination 200.1.1.1 to-multicast 230.1.0.1
config>router>pim>if# no shutdown
config>router>pim>if# exit
```

The outcome of the configuration is as follows:

- unicast source (1.1.1.1, 100.1.1.1) translates to multicast destination (100.1.1.1, 230.0.0.1) for interface loop1
- unicast source (1.1.1.3, 200.1.1.1) translates to multicast destination (200.1.1.1, 230.0.0.2) for interface loop2
- unicast source (2.1.1.1 to 2.1.1.2, 200.1.1.1) translates to multicast destination (200.1.1.1, 230.1.0.1 to 230.1.0.2) for interface loop2

The 7705 SAR supports both single-source multicast (SSM) and any-source multicast (ASM) models for unicast-to-multicast address translation.

With SSM, when hosts join a loopback address on the 7705 SAR that is doing the translation, IGP routes the PIM joins to this router. The PIM joins are routed to the 7705 SAR because the 7705 SAR translator router is configured as the source of the multicast traffic on the hosts. All multicast functionality is valid in the multicast domain, except that the multicast source is the 7705 SAR loopback IP address rather than a source that is connected to the 7705 SAR. Reverse path forwarding (RPF) is performed against the loopback address of the translated (S,G), so if the multicast traffic (S,G) arrives on a non-loopback interface, it will be dropped.

With ASM, if the 7705 SAR is both the rendezvous point (RP) and the unicast-to-multicast translator router, it receives packets from the unicast domain and translates their destination address to a multicast source address based on the configuration of the **unicast-to-multicast** command. The hosts (leaves) send a (\*,G) join message to the RP (which is the translator router), and the translator router forwards (loopback,G) traffic to the leaves. The leaves then send a join (loopback,G) message back to the RP.

If the 7705 SAR is not the RP but is the unicast-to-multicast translator router, it must be configured with RP parameters under the PIM interface. The 7705 SAR translates the unicast stream to (loopback,G), then encapsulates the (loopback,G) packets in a unicast packet and sends the unicast packet to the RP. This unicast packet is known as a "register" message in PIM. The RP removes the outer IP address and forwards the (loopback,G) packets to the leaves. The leaves then send a join (loopback,G) message back to the 7705 SAR translator router.

For ASM, only IPv4 addresses are supported.

### 3.11.2 Multicast-to-multicast address translation

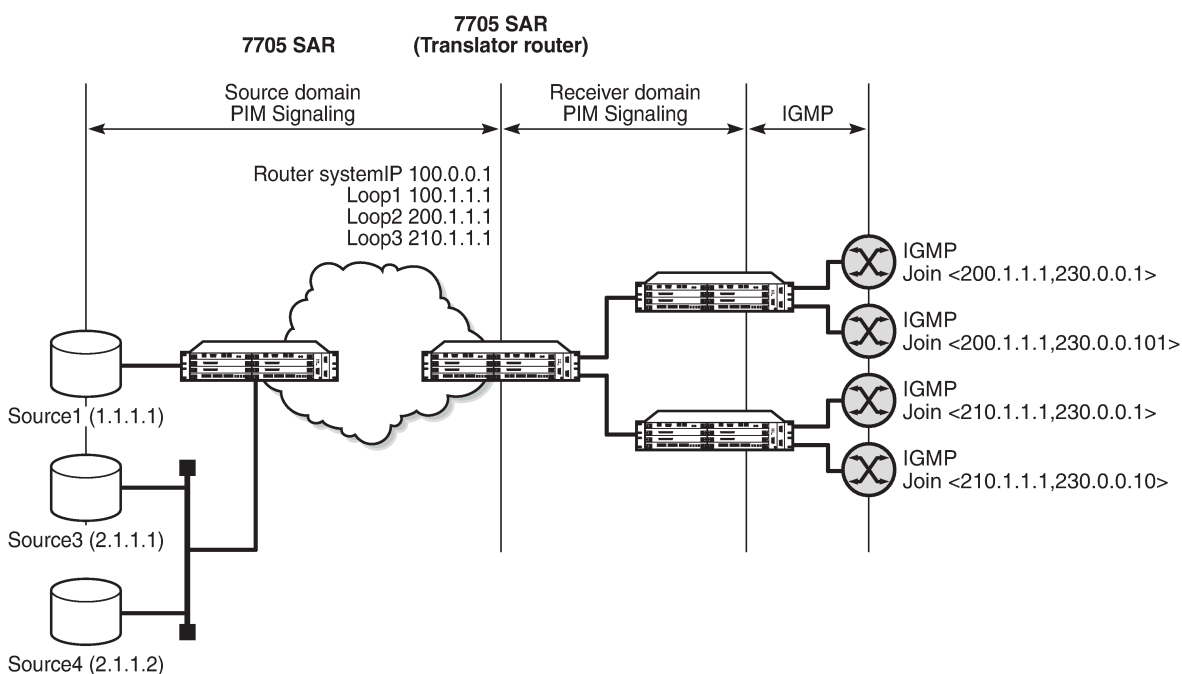
With multicast-to-multicast address translation, the 7705 SAR acts as a host to upstream (S,G)s. (S,G) packets arriving on the 7705 SAR are translated to a new downstream (S,G). Multiple upstream sources can be translated to a single downstream source. The overlapping groups between the two sources merge into one and are configured to a range of groups on the single downstream source.

Multicast-to-multicast configuration on the 7705 SAR is very similar to unicast-to-multicast configuration except that the 7705 SAR performing the address translation is configured with static IGMP join requests for interested (S,G)s toward the upstream source. For these (S,G)s, the 7705 SAR acts as the host and translates these streams based on the configuration of the **multicast-to-multicast** command. On the downstream (receiver domain), the 7705 SAR acts as the source of the translated streams to the hosts that want to join these (S,G)s.

Multicast-to-multicast translation is supported in the GRT and in VPRNs.

The following figure shows an example of the 7705 SAR acting as a multicast-to-multicast address translator.

Figure 9: Multicast-to-multicast address translation on the 7705 SAR



36406

In the figure, the 7705 SAR router with system IP address 100.0.0.1 is performing the translation. The translator router sends a static IGMP join request to interested streams in the source domain. The translator router is the host for these streams. The example below shows the configuration for a static IGMP join request.

**Example:**

```
config>router#
config>router>igmp# interface "to-source-domain"
config>router>igmp>if# static
```

```

config>router>igmp>if>static# group 230.0.0.1
config>router>igmp>if>static>group# source 1.1.1.1
config>router>igmp>if>static>group>source# exit
config>router>igmp>if>static# group 230.0.0.2
config>router>igmp>if>static>group# source 1.1.1.1
config>router>igmp>if>static>group>source# exit
config>router>igmp>if>static# group 230.0.0.100
config>router>igmp>if>static>group# source 1.1.1.1
config>router>igmp>if>static>group>source# exit
config>router>igmp>if>static# group 230.0.0.10
config>router>igmp>if>static>group# source 2.1.1.1
config>router>igmp>if>static>group>source# exit
config>router>igmp>if>static# group 230.0.0.1
config>router>igmp>if>static>group# source 2.1.1.2
config>router>igmp>if>static>group>source# exit
config>router>igmp>if>static# group 230.0.0.10
config>router>igmp>if>static>group# source 2.1.1.2
config>router>igmp>if>static>group>source# exit

```

To translate these source domain streams to receiver domain streams, a loopback interface on the translator router must be enabled for multicast translation. The example below shows the configuration.

**Example:**

```

config>router# interface "to-source-domain"
config>router>if# multicast-translation
config>router>if# exit

```

Under the loopback IP address on the PIM interface, the 7705 SAR creates a mapping between the upstream (S,G) and the downstream (S,G). The example below shows the configuration.

**Example:**

```

config>router# pim
config>router>pim# interface loop2
config>router>pim>if# multicast-to-multicast source 1.1.1.1 group-start
230.0.0.1 group-end 230.0.0.100 to-multicast 230.0.0.1
config>router>pim>if# multicast-to-multicast source 2.1.1.1 group-start
230.0.0.1 group-end 230.0.0.10 to-multicast 230.0.0.101
config>router>pim>if# no shutdown
config>router>pim>if# exit
config>router>pim# interface loop3
config>router>pim>if# multicast-to-multicast source 2.1.1.2 group-start
230.0.0.1 group-end 230.0.0.10 to-multicast 230.0.0.1
config>router>pim>if# no shutdown
config>router>pim>if# exit

```

The outcome of the configuration is as follows:

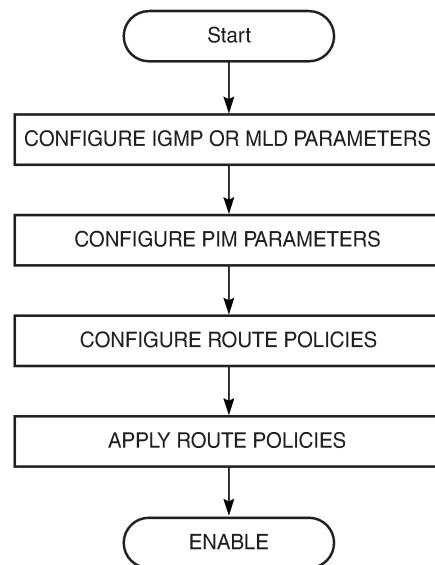
- multicast (1.1.1.1, 230.0.0.1) translates to multicast (200.1.1.1, 230.0.0.1)
- multicast (1.1.1.1, 230.0.0.100) translates to multicast (200.1.1.1, 230.0.0.100)
- multicast (2.1.1.1, 230.0.0.1) translates to multicast (200.1.1.1, 230.0.0.101)
- multicast (2.1.1.1, 230.0.0.10) translates to multicast (200.1.1.1, 230.0.0.110)
- multicast (2.1.1.2, 230.0.0.1) translates to multicast (210.1.1.1, 230.0.0.1)
- multicast (2.1.1.2, 230.0.0.10) translates to multicast (210.1.1.1, 230.0.0.10)

The configuration above also merges two different source domain sources, source 1.1.1.1 and 2.1.1.1, into a single receiver domain, 200.1.1.1. As well, overlapping groups are spread out into a group range of 230.0.0.1 to 230.0.0.110.

## 3.12 IP multicast configuration process overview

The following figure shows the process to configure multicast parameters.

Figure 10: IP multicast configuration process



23119

## 3.13 Configuration notes

The following guidelines and restrictions apply to multicast configuration:

- a multicast stream is required by one or more multicast clients
- a multicast stream is offered by one or more multicast servers
- unlike 7750 SR nodes, when the maximum number of groups per node limit is exceeded, the additional groups are not stored at the CSM layer and an alarm is raised immediately

## 3.14 Configuring IP multicast parameters with CLI

This section provides information to configure IP multicast, IGMP, MLD, and PIM.

Topics in this section include:

- [IP multicast configuration overview](#)
- [Basic IP multicast configuration](#)
- [Common configuration tasks](#)
- [Service management tasks](#)



## 3.15 IP multicast configuration overview

Nokia 7705 SAR routers use IGMP and MLD to manage membership of host receivers for a multicast session. The routers use PIM-SSM or PIM-SM to connect to the multicast source and to the network.

Traffic can only flow away from the router to an IGMP or MLD interface; it can flow both to and from a PIM interface. A router directly connected to a source of multicast traffic must have PIM enabled on the interface to that source. The traffic travels through a network from PIM interface to PIM interface, and arrives on an IGMP- or MLD-enabled interface.

### 3.15.1 IGMP and MLD

The IGMP and MLD CLI contexts are created when the **config>router>igmp** and **config>router>mld** commands are run. They are not operational until at least one interface is specified in the context, at which time the interface is enabled for IGMP or MLD and is called an IGMP or MLD interface. When enabled, the interface can be configured with IGMP or MLD parameters, which are in addition to the standard parameters for the interface when it is created.

You can filter traffic on an IGMP or MLD interface by defining and importing a routing policy. You can also define the maximum number of groups to which the interface can belong.



**Note:** Before an IP interface can be specified in an IGMP or MLD context, it must be created on the 7705 SAR (**config>router>interface** or **config>service>ies>interface**).

#### 3.15.1.1 Static groups

Static IGMP and MLD group memberships can be configured so that multicast forwarding can be set up without any host receivers in the group. When static IGMP or MLD group membership is enabled, data is forwarded to an interface even though membership reports from one or more host members have not been received.

When static IGMP or MLD group entries on point-to-point links that connect routers to a rendezvous point (RP) are configured, the static IGMP or MLD group entries do not generate join messages toward the RP. When a host wants to receive multicast sessions, it sends a join message to each multicast group it wants to join. When a host wants to leave a multicast session, it sends a Leave message to each multicast group it wants to leave.

A multicast router keeps a list of multicast group memberships for each attached network and an interval timer for each membership. Host receivers issue a Multicast Group Membership Report when they want to receive a multicast session. In MLDv2, Leaves and Joins are both sub-messages of Report messages. These reports are sent to all multicast routers.

#### 3.15.1.2 SSM translation

The 7705 SAR supports SSM translation at both the protocol level and the interface level for both IGMP and MLD. When configured at the protocol level, the specified group and source addresses apply to all newly created IGMP and MLD interfaces. Configuring **ssm-translation** at the interface level overrides any protocol-level values for the specified interface.

### 3.15.2 PIM

Use the **config>router>pim** command to enable the PIM CLI context. The PIM protocol is not operational until at least one interface is specified for it, at which time the interface is enabled for PIM and is called a PIM interface. Once enabled, a PIM interface can be configured with PIM parameters, which are in addition to the standard parameters for the interface when it is created. When PIM is operational, data is forwarded to network segments with active host receivers that have explicitly requested the multicast group.

**Note:**

- Before an IP interface can be specified in the PIM context, it must be created on the 7705 SAR (**config>router>interface** or **config>service>ies>interface**).
- PIM interfaces can be automatically created once an IP or IES interface has been created by using the **apply-to** command.

### 3.15.3 Hardware support

IGMP and MLD are supported on the following:

- all Ethernet adapter cards
- 6-port SAR-M Ethernet module
- 2-port 10GigE (Ethernet) module
- 4-port SAR-H Fast Ethernet module
- all datapath Ethernet ports on all fixed 7705 SAR platforms

PIM-SSM and PIM-SM are supported on the following:

- all Ethernet adapter cards
- 6-port SAR-M Ethernet module
- 2-port 10GigE (Ethernet) module
- 4-port SAR-H Fast Ethernet module
- all T1/E1 adapter cards
- all OC3/STM1 adapter cards
- the 4-port DS3/E3 Adapter card
- all datapath Ethernet ports on all fixed 7705 SAR platforms

## 3.16 Basic IP multicast configuration

Perform the following basic multicast configuration tasks:



**Note:** Interfaces are created using the **config>router>interface** or **config>service>ies>interface** command (IES only), and then enabled and configured for IGMP, MLD, or PIM using the **config>router>igmp>interface** or **mld>interface** or **pim>interface** command.

For IGMP:

- enable IGMP (required)
- configure IGMP interfaces (required)
- specify IGMP version on the interface (optional)
- configure static (S,G) or (\*,G) (optional)
- configure SSM translation (optional)

For MLD:

- enable MLD (required)
- configure MLD interfaces (required)
- specify MLD version on the interface (optional)
- configure static (S,G) or (\*,G) (optional)
- configure SSM translation (optional for (S,G), required for (\*,G))

For PIM:

- enable PIM (required)
- add interfaces so the protocol establishes adjacencies with the neighboring routers (required)
- configure a group-to-RP mapping (required) by either:
  - configuring static group-to-RP mapping
  - enabling candidate RP or bootstrap mechanism on some routers
- enable unicast routing protocols to learn routes toward the RP (for (\*,G)) and source (for (S,G)) for reverse path forwarding (required)
- add SSM ranges (optional)
- enable candidate BSR (optional)
- enable candidate RP (optional)
- change hello interval (optional)
- configure route policies (bootstrap-export, bootstrap-import, and import join and register) (optional)

For MSDP:

- enable MSDP (required)
- configure a peer
- configure the local address

The following examples show information displays for IGMP, MLD, PIM, and MSDP. For IGMP, MLD, and PIM, each protocol shows the following output:

- without an interface specified (detailed information)
- with an interface specified (detailed information)

## IGMP

```
*A:7705custDoc:Sar18>config>router>igmp# info detail
#-----
      query-interval 125
      query-last-member-interval 1
```

```

        query-response-interval 10
        robust-count 2
        no shutdown
#-----
*A:7705custDoc:Sar18>config>router>igmp# info detail
-----
    interface "igmp_interface"
    no import
    version 3
    subnet-check
    no max-groups
    no max-grp-sources
    no disable-router-alert-check
    no shutdown
    exit
    query-interval 125
    query-last-member-interval 1
    query-response-interval 10
    robust-count 2
    no shutdown
-----
*A:7705custDoc:Sar18>config>router>igmp#

```

**MLD**

```

*A:7705custDoc:Sar18>config>router>mld$ info detail
-----
    query-interval 125
    query-last-listener-interval 1
    query-response-interval 10
    robust-count 2
    no shutdown
-----
*A:7705custDoc:Sar18>config>router>mld$

```

```

*A:7705custDoc:Sar18>config>router>mld# info detail
-----
    interface "mld_interface"
    no import
    version 2
    no max-groups
    no disable-router-alert-check
    no query-interval
    no query-response-interval
    no query-last-listener-interval
    no shutdown
    exit
    query-interval 125
    query-last-listener-interval 1
    query-response-interval 10
    robust-count 2
    no shutdown
-----
*A:7705custDoc:Sar18>config>router>mld#

```

**PIM**

```

*A:7705custDoc:Sar18>config>router>pim# info detail
-----
    rpf-table rtable-u

```

```

rpf6-table rtable6-u
no import join-policy
no import register-policy
apply-to none
rp
  no bootstrap-import
  no bootstrap-export
  static
  exit
  bsr-candidate
    shutdown
    priority 0
    hash-mask-len 30
    no address
  exit
  rp-candidate
    shutdown
    no address
    holdtime 150
    priority 192
  exit
exit
no non-dr-attract-traffic
no ssm-default-range-disable ipv4
no ssm-default-range-disable ipv6
no shutdown
no ipv4-multicast-disable
ipv6-multicast-disable

```

```
-----
*A:7705custDoc:Sar18>config>router>pim#
```

```
*A:7705custDoc:Sar18>config>router>pim# info detail
```

```
-----
rpf-table rtable-u
rpf6-table rtable6-u
no import join-policy
interface "pim_interface"
  hello-interval 30
  hello-multiplier 35
  no tracking-support
  no improved-assert
  no bfd-enable
  no bfd-enable ipv6
  no three-way-hello
  priority 1
  multicast-senders auto
  no bsm-check-rtr-alert
  no sticky-dr
  no max-groups
  no assert-period
  no instant-prune-echo
  no shutdown
  no ipv4-multicast-disable
  no ipv6-multicast-disable
exit
apply-to none
rp
  no bootstrap-import
  no bootstrap-export
  static
  exit
  bsr-candidate
    shutdown

```

```

        priority 0
        hash-mask-len 30
        no address
    exit
    rp-candidate
    shutdown
    no address
    holdtime 150
    priority 192
    exit
exit
no non-dr-attract-traffic
no ssm-default-range-disable ipv4
no ssm-default-range-disable ipv6
no shutdown
no ipv4-multicast-disable
ipv6-multicast-disable

```

```
-----
*A:7705custDoc:Sar18>config>router>pim#
```

## MSDP

```
*A:7705custDoc:Sar18>config>router>msdp# info detail
```

```
-----
peer 10.20.1.1
    local-address 10.20.1.6
exit

```

```
-----
*A:7705custDoc:Sar18>config>router>pim#
```

## 3.17 Common configuration tasks

The following sections show the CLI syntax and examples for:

- [Configuring IGMP and MLD parameters](#)
- [Configuring PIM parameters](#)

### 3.17.1 Configuring IGMP and MLD parameters

This section contains the following subsections:

- [Enabling IGMP or MLD](#)
- [Configuring IGMP and MLD](#)
- [Configuring IGMP and MLD interfaces](#)
- [Configuring IGMP and MLD interface static multicast](#)
- [Configuring IGMP and MLD SSM translation](#)

### 3.17.1.1 Enabling IGMP or MLD

Use the following CLI syntax to enable IGMP or MLD.

**CLI syntax:**

```
config>router# igmp
```

**CLI syntax:**

```
config>router# mld
```

The following displays an enabled IGMP example. An MLD display would look similar.

```
*A:7705custDoc:Sar18>config>router# info detail
...
#-----
echo "IGMP Configuration"
#-----
  igmp
    query-interval 125
    query-last-member-interval 1
    query-response-interval 10
    robust-count 2
    no shutdown
  exit
#-----
*A:7705custDoc:Sar18>config>system#
```

### 3.17.1.2 Configuring IGMP and MLD

Use the following CLI syntax to configure IGMP or MLD:

**CLI syntax:**

```
config>router# igmp
  query-interval seconds
  query-last-member-interval seconds
  query-response-interval seconds
  robust-count robust-count
  [no] shutdown
```

**CLI syntax:**

```
config>router# mld
  query-interval seconds
  query-last-member-interval seconds
  query-response-interval seconds
  robust-count robust-count
  [no] shutdown
```

The following displays an IGMP configuration example. An MLD example would look similar.

**Example:**

```
config>router# igmp
config>router>igmp# query-interval 150
config>router>igmp>if# query-last-member-interval 3
config>router>igmp>if# query-response-interval 15
config>router>igmp>if# robust count 3
```

```
config>router>igmp>if# exit
```

```
*A:7705custDoc:Sar18>config>router>igmp# info detail
```

```
-----
query-interval 150
query-last-member-interval 3
query-response-interval 15
robust-count 3
no shutdown
-----
```

```
*A:7705custDoc:Sar18>config>router>igmp#
```

### 3.17.1.3 Configuring IGMP and MLD interfaces

IGMP and MLD are supported on both access and network interfaces.



**Note:** MLD "query" parameters can be configured at both the MLD protocol and interface levels. When configured at the protocol level, settings apply to all new interfaces added to the context. Configuring the "query" parameters at the interface level overrides the protocol-level configuration for the specified interface.

See [Configuring IGMP and MLD](#) for an example of query parameter configuration.

Use the following CLI syntax to configure an IGMP or MLD interface:

#### CLI syntax:

```
config>router# igmp
interface ip-int-name
  [no] disable-router-alert-check
  [no] import policy-name
  [no] max-groups value
  [no] max-grp-sources value
  [no] subnet-check
  [no] version version
  [no] shutdown
```

#### CLI syntax:

```
config>router# mld
interface ip-int-name
  [no] disable-router-alert-check
  [no] import policy-name
  [no] max-groups value
  [no] query-interval seconds
  [no] query-last-member-interval seconds
  [no] query-response-interval seconds
  [no] version version
  [no] shutdown
```

The following example displays IGMP interface configuration command usage. An MLD interface example would look similar.

#### Example:

```
config>router#
config>router>igmp# interface "igmp_interface"
config>router>igmp>if# max-groups 3
config>router>igmp>if# max-grp-sources 2
config>router>igmp>if# import igmp_policy1
```



```
config>router>igmp>if# exit
```

The following example displays the IGMP interface configuration:

```
*A:7705custDoc:Sar18>config>router>igmp>interface# info detail
-----
interface "igmp_interface"
  import igmp_policy1
  version 3
  subnet-check
  max-groups 3
  max-grp-sources 2
  no disable-router-alert-check
  no shutdown
exit
-----
*A:7705custDoc:Sar18>config>router>igmp#
```

### 3.17.1.4 Configuring IGMP and MLD interface static multicast

The maximum number of static groups and sources that can be configured on a group interface is controlled by the **max-groups** and **max-grp-sources** commands. A static (\*,G) cannot be added to a group if an (S,G) exists. Similarly, a static (S,G) cannot be added to a group if a (\*,G) exists.

A static group is not created until a source has been specified.

Use the following syntax to configure an IGMP or MLD static multicast group and source for a multicast interface:

#### CLI syntax:

```
config>router# igmp
  interface ip-int-name
  static
    group grp-ip-address
    source ip-address
  starg
```

#### CLI syntax:

```
config>router# mld
  interface ip-int-name
  static
    group grp-ipv6-address
    source ipv6-address
  starg
```

The following example displays an IGMP interface configuration for static multicast. An MLD interface example would look similar except that it would use IPv6 group and source addresses.

#### Example:

```
config>router>igmp# interface igmp_interface
config>router>igmp>if# static
config>router>igmp>if>static# group 239.255.1.3
config>router>igmp>if>static>group# source 10.0.2.8
config>router>igmp>if>static>group# source 10.0.2.9
config>router>igmp>if>static# group 239.255.0.3
config>router>igmp>if>static>group# exit
config>router>igmp>if>static>group# source 10.0.184.197
config>router>igmp>if>static>group# source 10.0.184.198
```

```
config>router>igmp>if>static>group# exit
config>router>igmp>if>static# exit
config>router>igmp>if# exit
```

The following example displays the configuration for IGMP. An MLD example would look similar except that it would use IPv6 group and source addresses.

```
A:7705custDoc:Sar18>config>router>igmp# info
-----
interface "igmp_interface"
  static
    group 239.255.1.3
      source 10.0.2.8
      source 10.0.2.9
    exit
  group 239.255.0.3
    source 10.0.184.197
    source 10.0.184.198
  exit
exit
exit
-----
A:7705custDoc:Sar18>config>router>igmp#
```

### 3.17.1.5 Configuring IGMP and MLD SSM translation

SSM translation can be configured for IGMP and MLD at the protocol and the interface levels. When configured at the protocol level, settings apply to all new interfaces added to the context. Configuring SSM translation at the interface level overrides the protocol-level configuration for the specified interface.

The group range is not created until a source has been specified.

Use the following syntax to configure IGMP and MLD SSM translation parameters at the protocol and interface levels:

#### CLI syntax:

```
config>router# igmp
  ssm-translate
  grp-range start end
  source ip-address
```

#### CLI syntax:

```
config>router# igmp
  interface ip-int-name
  ssm-translate
  grp-range start end
  source ip-address
```

#### CLI syntax:

```
config>router# mld
  ssm-translate
  grp-range start end
  source ipv6-address
```

#### CLI syntax:

```
config>router# mld
  interface ip-int-name
```

```

ssm-translate
  grp-range start end
  source ipv6-address

```

The following example displays the command usage to configure IGMP SSM translation at the protocol and interface levels. Examples for MLD protocol and MLD interfaces would look similar. MLD would use IPv6 group and source addresses.

**Example:**

```

config>router# igmp
config>router>igmp# ssm-translate
config>router>igmp>ssm# grp-range 192.0.2.0 192.0.2.10
config>router>igmp>ssm>grp-range# source 10.10.10.100
config>router>igmp>ssm>grp-range# exit
config>router>igmp# interface igmp_if
config>router>igmp>interface>ssm# grp-range 192.0.2.20 192.0.2.30
config>router>igmp>interface>ssm>grp-range# source 10.10.10.110
config>router>igmp>interface>ssm>grp-range# source 10.10.10.111

```

The following example displays the SSM translation configuration at the IGMP protocol and interface levels:

```

A:7705custDoc:Sar18>config>router>igmp# info
-----
  ssm-translate
    grp-range 192.0.2.0 192.0.2.10
    source 10.10.10.100
  exit
  interface "igmp_if"
    max-groups 2
    max-grp-sources 3
    ssm-translate
      grp-range 192.0.2.20 192.0.2.30
      source 10.10.10.110
      source 10.10.10.111
    exit
  -----
A:7705custDoc:Sar18>config>router>igmp# exit

```

## 3.17.2 Configuring PIM parameters

This section contains the following subsections:

- [Enabling PIM](#)
- [Configuring PIM interface parameters](#)
- [Configuring a rendezvous point \(RP\)](#)
- [Importing PIM join or register policies](#)
- [Configuring MSDP parameters](#)

### 3.17.2.1 Enabling PIM

When configuring PIM, make sure to enable PIM on all interfaces for the routing instance; otherwise, multicast routing errors can occur.

Use the following CLI syntax to enable PIM.

**CLI syntax:**

```
config>router# pim
```

The following example displays the detailed output when PIM is enabled without a PIM interface configured. See [Configuring PIM interface parameters](#) for the additional configuration settings when a PIM interface is configured.

**Without a PIM interface enabled**

```
*A:7705custDoc:Sar18>config>router>pim# info detail
-----
rpf-table rtable-u
rpf6-table rtable6-u
no import join-policy
no import register-policy
apply-to none
rp
  no bootstrap-import
  no bootstrap-export
  static
  exit
  bsr-candidate
    shutdown
    priority 0
    hash-mask-len 30
    no address
  exit
  rp-candidate
    shutdown
    no address
    holdtime 150
    priority 192
  exit
exit
no non-dr-attract-traffic
no ssm-default-range-disable ipv4
no ssm-default-range-disable ipv6
no shutdown
no ipv4-multicast-disable
ipv6-multicast-disable
-----
*A:7705custDoc:Sar18>config>router>pim#
```

**With a PIM interface enabled**

```
*A:7705custDoc:Sar18>config>router>pim# info detail
-----
rpf-table rtable-u
rpf6-table rtable6-u
no import join-policy
no import register-policy
interface "pim_interface"
  hello-interval 30
  hello-multiplier 35
  no tracking-support
  no bfd-enable
  no bfd-enable ipv6
  no three-way-hello
  priority 1
  multicast-senders auto
-----
```

```

        no bsm-check-rtr-alert
        no sticky-dr
        no max-groups
        no assert-period
        no instant-prune-echo
        no shutdown
        no ipv4-multicast-disable
        no ipv6-multicast-disable
    exit
    apply-to none
    rp
        no bootstrap-import
        no bootstrap-export
    exit
    no non-dr-attract-traffic
    no shutdown
    no ipv4-multicast-disable
    ipv6-multicast-disable
-----
*A:7705custDoc: Sar18>config>router>pim#

```

### 3.17.2.2 Configuring PIM interface parameters

To create a PIM interface, first create an IP interface using the **config>router>interface** or the **config>service>ies>interface** command (IES only). Then use the **config>router>pim>interface** command to configure PIM interface parameters.

The following example displays the command usage to configure PIM interface parameters:

#### Example:

```

config>router# pim
config>router>pim# interface "pim_interface"
config>router>pim>if# assert-period assert-period
config>router>pim>if# [no] bfd-enable [ipv4 | ipv6]
config>router>pim>if# [no] bsm-check-rtr-alert
config>router>pim>if# hello-interval hello-interval
config>router>pim>if# hello-multiplier deci-units
config>router>pim>if# instant-prune-echo
config>router>pim>if# [no] ipv4-multicast-disable
config>router>pim>if# [no] ipv6-multicast-disable
config>router>pim>if# max-groups value
config>router>pim>if# multicast-senders auto
config>router>pim>if# priority dr-priority
config>router>pim>if# [no] shutdown
config>router>pim>if# sticky-dr [priority dr-priority]
config>router>pim>if# [no] three-way-hello
config>router>pim>if# [no] tracking-support
config>router>pim>if# exit

```

The following example displays the detailed PIM interface configuration:

```

*A:7705custDoc: Sar18>config>router>pim# info detail
-----
...
    interface "pim_interface"
        hello-interval 30
        hello-multiplier 35
        no tracking-support
        no bfd-enable
        no bfd-enable ipv6

```

```

no three-way-hello
multicast-senders auto
no bsm-check-rtr-alert
priority 1
no sticky-dr
no max-groups
no assert-period
no instant-prune-echo
no shutdown
no ipv4-multicast-disable
no ipv6-multicast-disable
exit
...

```

### 3.17.2.3 Configuring a rendezvous point (RP)

When configuring an RP, you can configure parameters for an RP candidate, a BSR candidate, or a static RP.

The following example displays the command usage to configure an RP:

**Example:**

```

config>router# pim
config>router>pim# rp
config>router>pim>rp# anycast rp-ip-address
config>router>pim>rp>anycast# rp-set-peer ip-address
config>router>pim>rp# auto-rp-discovery
config>router>pim>rp# bootstrap-export policy-name
config>router>pim>rp# bootstrap-import policy-name
config>router>pim>rp# bsr-candidate
config>router>pim>rp>bsr-candidate# address ip-address
config>router>pim>rp# rp-candidate
config>router>pim>rp>rp-candidate# address ip-address
config>router>pim>rp>rp-candidate# group-range {grp-ip-address/mask | grp-
ip-address netmask}
config>router>pim>rp# static
config>router>pim>rp>static# address ip-address
config>router>pim>rp>static# group-prefix {grp-ip-address/mask | grp-ip-
address netmask}
config>router>pim>rp>static# override

```

The following example displays the detailed RP configuration:

```

*A:7705custDoc:Sar18 Dut-B>config>router>pim>rp# info detail
-----
no bootstrap-import
no bootstrap-export
static
exit
bsr-candidate
shutdown
priority 0
hash-mask-len 30
no address
exit
rp-candidate
shutdown
no address
group-range 224.0.0.0/4
group-range 224.0.0.0/8

```

```

group-range 224.0.0.0/12
holdtime 150
priority 192
exit
anycast 10.10.10.12
rp-set-peer 10.10.10.13
exit

```

### 3.17.2.4 Importing PIM join or register policies

The **import** command provides a mechanism to control the (\*,G) or (S,G) state that gets created on a router. Import policies are defined in the **config>router>policy-options** context.

Up to five join policies can be included in a single **join-policy** command and up to five register policies can be included in a single **register-policy** command. Each use of the **join-policy** or **register-policy** command overrides the previous use and resets the list of import policies.



**Note:** In the import policy, if a policy **action** is not specified in the **entry**, the **default-action** takes precedence. Similarly, if there are no **entry** matches, the **default-action** takes precedence. If no **default-action** is specified, the default **default-action** is executed.

Use the following commands to import PIM join policies:

#### CLI syntax:

```

config>router# pim
import {join-policy | register-policy} [policy-name [...up to 5 max]]

```

The following example displays the commands used to import a join policy statement named "pim\_join". The example also displays the commands used to import three register policies. For information about configuring a join or register policy, see the "Configuring PIM join or register policies" section in the 7705 SAR Router Configuration Guide.

#### Example:

```

config>router# pim
config>router>pim# import join-policy "pim_join"
config>router>pim# import register-policy "register_join" "register_join2"
"register_join3"
config>router>pim# no shutdown

```

The following example displays the PIM configuration:

```

A:7705custDoc:Sar18>config>router>pim# info
-----
...
import join-policy "pim_join"
import register-policy "register_join" "register_join2" "register_join3"
interface "pim_interface"
exit
...
-----
A:7705custDoc:Sar18>config>router>pim#

```

### 3.17.2.5 Configuring MSDP parameters

Use the following CLI syntax to configure MSDP parameters:

**CLI syntax:**

```
config>router# msdp
  peer peer-address
    active-source-limit number
    authentication-key [authentication-key|hash-key]
    [hash|hash2]
    default-peer
    export policy-name [policy-name...(up to 5 max)]
    import policy-name [policy-name...(up to 5 max)]
    local-address address
    receive-msdp-msg-rate number interval seconds [threshold number]
    no shutdown
  no shutdown
```

The following example displays the command usage to configure basic MSDP parameters.

**Example:**

```
config>router>msdp# peer 10.20.1.1
config>router>msdp>peer# local-address 10.20.1.6
config>router>msdp>peer# no shutdown
config>router>msdp>peer# exit
config>router>msdp# no shutdown
config>router>msdp#
```

The following example displays the basic MSDP for configuration.

```
ALA-48>config>router>msdp# info
-----
  peer 10.20.1.1
    local-address 10.20.1.6
  exit
-----
ALA-48>config>router>msdp#
```

## 3.18 Service management tasks

This section discusses the following multicast configuration management tasks:

- [Disabling IGMP, MLD, PIM, and MSDP](#)

### 3.18.1 Disabling IGMP, MLD, PIM, and MSDP

To disable IP multicast, disable PIM and disable IGMP or MLD (or both).

Use the following CLI syntax to disable IGMP, MLD, PIM, and MSDP:

**CLI syntax:**

```
config>router#
  igmp
  shutdown
  mld
```



```
shutdown
pim
shutdown
msdp
shutdown
```

The following example displays the command usage to disable multicast:

**Example:**

```
config>router# igmp
config>router>igmp# shutdown
config>router>igmp# exit
config>router# mld
config>router>mld# shutdown
config>router>mld# exit
config>router# pim
config>router>pim# shutdown
config>router>pim# exit
config>router# msdp
config>router>msdp# shutdown
config>router>msdp# exit
```

The following example displays the configuration outputs:

```
*A:7705custDoc:Sar18>config>router>igmp# info detail
-----
shutdown
interface "igmp_interface"
  no import
  version 3
  subnet-check
  no max-groups
  no disable-router-alert-check
  ssm-translate
    grp-range 239.255.0.0 239.255.20.20
    source 10.10.10.10
  exit
  grp-range 239.255.50.50 239.255.70.70
  source 10.10.10.11
  exit
  exit
  no shutdown
exit
query-interval 125
query-last-member-interval 1
query-response-interval 10
robust-count 2
-----
*A:7705custDoc:Sar18>config>router>igmp#
```

```
*A:7705custDoc:Sar18>config>router>mld# info detail
-----
shutdown
interface "mld_interface"
  no import
  version 2
  no max-groups
  no disable-router-alert-check
  no query-interval
  no query-response-interval
  no query-last-listener-interval
```

```

        no shutdown
        exit
        query-interval 125
        query-last-listener-interval 1
        query-response-interval 10
        robust-count 2
-----
*A:7705custDoc: Sar18>config>router>mld#

```

```

*A:7705custDoc: Sar18>config>router>pim# info detail
-----
        shutdown
        rpf-table rtable-u
        rpf6-table rtable6-u
        no import join-policy
        interface "pim_interface"
            hello-interval 30
            hello-multiplier 35
            no tracking-support
            no bfd-enable
            no bfd-enable ipv6
            no three-way-hello
            priority 1
            no sticky-dr
            no max-groups
            no assert-period
            instant-prune-echo
            no shutdown
            no ipv4-multicast-disable
            no ipv6-multicast-disable
        exit
        apply-to all
        rp
            no bootstrap-import
            no bootstrap-export
        exit
        no non-dr-attract-traffic
        no ipv4-multicast-disable
        ipv6-multicast-disable
-----
*A:7705custDoc: Sar18>config>router>pim#

```

```

#-----
echo "MSDP Configuration"
#-----
        msdp
            shutdown
            peer 10.20.1.1
            local-address 10.20.1.6
            exit
            group "test"
                active-source-limit 50000
                receive-msdp-msg-rate 100 interval 300 threshold 5000
                export "LDP-export"
                import "LDP-import"
                local-address 10.10.10.103
                mode mesh-group
                peer 10.10.10.104
            exit
        exit
#-----

```

## 3.19 IP multicast command reference

### 3.19.1 Command hierarchies

- Configuration commands
  - IGMP commands
  - MLD commands
  - PIM commands
  - MSDP commands
- Show commands
- Clear commands
- Monitor commands
- Debug commands
- Tools Commands (see the Tools chapter in the 7705 SAR OAM and Diagnostics Guide)

#### 3.19.1.1 Configuration commands

##### 3.19.1.1.1 IGMP commands

```

configure
- router
  - [no] igmp
    - [no] interface ip-int-name
      - [no] disable-router-alert-check
      - import policy-name
      - no import
      - max-groups value
      - no max-groups
      - max-grp-sources value
      - no max-grp-sources
      - [no] shutdown
      - ssm-translate
        - [no] grp-range start end
        - [no] source ip-address
      - static
        - [no] group grp-ip-address
        - [no] source ip-address
      - [no] subnet-check
      - version version
      - no version
    - query-interval seconds
    - no query-interval
    - query-last-member-interval seconds
    - no query-last-member-interval
    - query-response-interval seconds
    - no query-response-interval
    - robust-count robust-count
    - no robust-count
  
```

```

- [no] shutdown
- ssm-translate
  - [no] grp-range start end
    - [no] source ip-address

```

### 3.19.1.1.2 MLD commands

```

configure
- router
  - [no] mld
    - [no] interface ip-int-name
      - [no] disable-router-alert-check
      - import policy-name
      - no import
      - max-groups value
      - no max-groups
      - query-interval seconds
      - no query-interval
      - query-last-listener-interval seconds
      - no query-last-listener-interval
      - query-response-interval seconds
      - no query-response-interval
      - [no] shutdown
      - no ssm-translate
        - [no] grp-range start end
          - [no] source ipv6-address
      - static
        - [no] group grp-ipv6-address
          - [no] source src-ipv6-address
      - version version
      - no version
    - query-interval seconds
    - no query-interval
    - query-last-listener-interval seconds
    - no query-last-listener-interval
    - query-response-interval seconds
    - no query-response-interval
    - robust-count seconds
    - no robust-count
    - [no] shutdown
    - no ssm-translate
      - [no] grp-range start end
        - [no] source src-ipv6-address

```

### 3.19.1.1.3 PIM commands

```

configure
- router
  - [no] pim
    - apply-to {ies | non-ies | all | none}
    - import {join-policy | register-policy} policy-name[.. policy-name (up to 5 max)]
    - no import {join-policy | register-policy}
    - [no] interface ip-int-name
      - assert-period assert-period
      - no assert-period
      - [no] bfd-enable [ipv4 | ipv6]
      - [no] bsm-check-rtr-alert
      - hello-interval hello-interval

```

```

- no hello-interval
- hello-multiplier deci-units
- no hello-multiplier
- [no] instant-prune-echo
- [no] ipv4-multicast-disable
- [no] ipv6-multicast-disable
- max-groups value
- no max-groups
- multicast-senders {auto | always | never}
- no multicast-senders
- multicast-to-multicast source ip-address group-start ip-address group-end ip-
address to-multicast group-address
- no multicast-to-multicast
- priority dr-priority
- no priority
- [no] shutdown
- sticky-dr [priority dr-priority]
- no sticky-dr
- [no] three-way-hello
- [no] tracking-support
- unicast-to-multicast unicast-start ip-address unicast-end ip-address
destination ip-address to-multicast ip-address
- no unicast-to-multicast
- [no] ipv4-multicast-disable
- [no] ipv6-multicast-disable
- [no] non-dr-attract-traffic
- rp
- [no] anycast rp-ip-address
- [no] rp-set-peer ip-address
- [no] auto-rp-discovery
- bootstrap-export policy-name[...policy-name (up to 5 max)]
- no bootstrap-export
- bootstrap-import policy-name[...policy-name (up to 5 max)]
- no bootstrap-import
- bsr-candidate
- address ipv4-address
- no address
- hash-mask-len hash-mask-length
- no hash-mask-len
- priority bootstrap-priority
- no priority
- [no] shutdown
- rp-candidate
- address ip-address
- no address
- [no] group-range {grp-ip-address/mask | grp-ip-address netmask}
- holdtime holdtime
- no holdtime
- priority priority
- no priority
- [no] shutdown
- static
- [no] address ip-address
- [no] group-prefix {grp-ip-address/mask | grp-ip-address netmask}
- [no] override
- rpf-table {rtable-m | rtable-u | both}
- no rpf-table
- rpf6-table {rtable6-m | rtable6-u | both}
- no rpf6-table
- [no] shutdown
- spt-switchover-threshold {grp-ipv4-prefix/ipv4-prefix-length | grp-ipv4-
prefix netmask | grp-ipv6-prefix/ipv6-prefix-length} spt-threshold
- no spt-switchover-threshold {grp-ipv4-prefix/ipv4-prefix-length | grp-ipv4-
prefix netmask | grp-ipv6-prefix/ipv6-prefix-length}

```

```

- [no] ssm-default-range-disable ipv4
- [no] ssm-default-range-disable ipv6
- [no] ssm-groups
  - [no] group-range {ip-prefix/mask | ip-prefix netmask}

```

### 3.19.1.1.4 MSDP commands

```

config
- router
  - [no] msdp
    - [no] active-source-limit number
    - [no] data-encapsulation
    - export policy-name [policy-name...(up to 5 max)]
    - no export
    - [no] group group-name
      - active-source-limit number
      - no active-source-limit
      - export policy-name [policy-name...(up to 5 max)]
      - no export
      - import policy-name [policy-name...(up to 5 max)]
      - no import
      - local-address address
      - no local-address
      - mode {mesh-group | standard}
    - [no] peer peer-address
      - active-source-limit number
      - no active-source-limit
      - authentication-key [authentication-key | hash-key] [hash | hash2]
      - no authentication-key
      - [no] default-peer
      - export policy-name [policy-name...(up to 5 max)]
      - no export
      - import policy-name [policy-name...(up to 5 max)]
      - no import
      - local-address address
      - no local-address
      - receive-msdp-msg-rate number interval seconds [threshold number]
      - no receive-msdp-msg-rate
      - [no] shutdown
      - receive-msdp-msg-rate number interval seconds [threshold number]
      - no receive-msdp-msg-rate
    - [no] shutdown
  - import policy-name [policy-name...(up to 5 max)]
  - no import
  - local-address address
  - no local-address
  - [no] peer peer-address
    - active-source-limit number
    - no active-source-limit
    - authentication-key [authentication-key | hash-key] [hash | hash2]
    - no authentication-key
    - [no] default-peer
    - export policy-name [policy-name...(up to 5 max)]
    - no export
    - import policy-name [policy-name...(up to 5 max)]
    - no import
    - local-address address
    - no local-address
    - receive-msdp-msg-rate number interval seconds [threshold number]
    - no receive-msdp-msg-rate
    - [no] shutdown

```

```

- receive-msdp-msg-rate number interval seconds [threshold number]
- no receive-msdp-msg-rate
- rpf-table {rtable-m | rtable-u | both}
- no rpf-table
- sa-timeout seconds
- no sa-timeout
- [no] shutdown
- [no] source ip-prefix/mask
  - active-source-limit number
  - no active-source-limit

```

### 3.19.1.2 Show commands

```

show
- router
  - igmp
    - group [grp-ip-address]
    - group summary
    - interface [ip-int-name | ip-address] [group] [grp-ip-address] [detail]
    - ssm-translate [interface-name]
    - static [ip-int-name | ip-address]
    - statistics [ip-int-name | ip-address]
    - status

```

```

show
- router
  - mld
    - group [grp-ipv6-address]
    - interface [ip-int-name | ip-address] [group] [grp-ipv6-address] [detail]
    - ssm-translate [ip-int-name]
    - static [ip-int-name | ip-address]
    - statistics [ip-int-name | ipv6-address]
    - status

```

```

show
- router
  - pim
    - group [grp-ip-address] [source ip-address] [detail] [family]
    - interface [ip-int-name | ip-address] [group grp-ip-address] [source ip-address]
    [detail] [family]
    - interface ip-int-name
      - multicast-translation type {unicast-to-multicast | multicast-to-multicast}
    - neighbor [ip-int-name | ip-address [address neighbor-ip-address]] [detail]
    [family]
    - rp [family | ip-address]
    - rp-hash [family | ip-address]
    - s-pmsi [family | ip-address]
    - statistics [ip-int-name | ip-address] [family]
    - status [detail] [family]

```

```

show
- router
  - msdp
    - group [group-name] [detail]
    - peer [ip-address] [group group-name] [detail]
    - source [ip-address/mask] [type {configured | dynamic | both}] [detail]
    - source-active [{group ip-address | local | originator ip-address | peer ip-address | source ip-address | group ip-address source ip-address}] [detail]

```

```

- source-active-rejected [peer-group name] [group ip-address] [source ip-address]
[originator ip-address] [peer ip-address]
- statistics [peer ip-address]
- status

```

### 3.19.1.3 Clear commands

```

clear
- router
- igmp
- database [interface ip-int-name | ip-address] [group grp-ip-address [source src-
ip-address]]
- statistics [ip-int-name | ip-address]
- version [ip-int-name | ip-address]

```

```

clear
- router
- mld
- database [interface ip-int-name | ipv6-address] [group grp-ipv6-address
[source src-ipv6-address]]
- statistics [ip-int-name | ipv6-address]
- version [ip-int-name | ip-address]

```

```

clear
- router
- pim
- database [interface ip-int-name | ip-address] [group grp-ip-address [source ip-
address]] [family]
- neighbor [ip-int-name] [family]
- statistics [family]
- statistics interface ip-int-name | ip-address [family]
- statistics group grp-ip-address [source ip-address] [family]

```

```

clear
- router
- msdp
- cache [peer ip-address] [group ip-address] [source ip-address] [originrp ip-
address]
- statistics [peer ip-address]

```

### 3.19.1.4 Monitor commands

```

monitor
- router
- pim
- group grp-ip-address [source ip-address] [interval interval] [repeat repeat]
[absolute | rate]

```

### 3.19.1.5 Debug commands

```

debug
- router

```



```

- [no] igmp
  - [no] interface [ip-int-name | ip-address]
  - [no] misc
  - packet [query | v1-report | v2-report | v3-report | v2-leave] [ip-int-name | ip-address]
  - no packet

```

```

debug
- router
  - [no] mld
  - [no] interface [ip-int-name | ipv6-address]
  - [no] misc
  - packet [query | v1-report | v2-report | v1-done] [ip-int-name | ipv6-address]
  - no packet

```

```

debug
- router
  - [no] msdp
  - packet [pkt-type] [peer ip-address]
  - no packet
  - pim [grp-address]
  - no pim
  - rtm [rp-address]
  - no rtm
  - sa-db [group grpAddr] [source srcAddr] [rp rpAddr]
  - no sa-db

```

```

debug
- router
  - [no] mtrace
  - [no] misc
  - [no] packet [query | request | response]

```

```

debug
- router
  - [no] pim
  - [no] adjacency
  - all [group grp-ip-address] [source ip-address] [detail]
  - no all
  - assert [group grp-ip-address] [source ip-address] [detail]
  - no assert
  - auto-rp [detail]
  - no auto-rp
  - bgp [group grp-ip-address] [source ip-address] [peer peer-ip-address] [detail]
  - no bgp
  - bsr [detail]
  - no bsr
  - data [group grp-ip-address] [source ip-address] [detail]
  - no data
  - db [group grp-ip-address] [source ip-address] [detail]
  - no db
  - interface [ip-int-name | ip-address] [detail]
  - no interface
  - jp [group grp-ip-address] [source ip-address] [detail]
  - no jp
  - mrrib [group grp-ip-address] [source ip-address] [detail]
  - no mrrib
  - msg [detail]
  - no msg
  - packet [hello | register | register-stop | jp | bsr | assert | crp] [ip-int-name | ip-address]

```

```
- no packet
- [no] red [detail]
- register [group grp-ip-address] [source ip-address] [detail]
- no register
- rtm [detail]
- no rtm
```

## 3.19.2 Command descriptions

- [Configuration commands](#)
- [Show commands](#)
- [Clear commands](#)
- [Monitor commands](#)
- [Debug commands](#)

### 3.19.2.1 Configuration commands

- [Generic commands](#)
- [IGMP commands](#)
- [MLD commands](#)
- [PIM commands](#)
- [MSDP commands](#)

#### 3.19.2.1.1 Generic commands

##### shutdown

##### Syntax

[no] shutdown

##### Context

config>router>igmp

config>router>igmp>interface

config>router>mld

config>router>mld>interface

config>router>msdp

config>router>msdp>group

config>router>msdp>group>peer

config>router>msdp>peer

config>router>pim

config>router>pim>interface

config>router>pim>rp>bsr-candidate

config>router>pim>rp>rp-candidate

## Description

This command administratively disables the entity. When disabled, an entity does not change, reset, or remove any configuration settings or statistics. Many entities must be explicitly enabled using the **no shutdown** command.

The operational state of the entity is disabled as well as the operational state of any entities contained within. Many objects must be shut down before they can be deleted.

Unlike other commands and parameters where the default state is not indicated in the configuration file, **shutdown** and **no shutdown** are always indicated in system-generated configuration files.

The **no** form of the command puts an entity into the administratively enabled state.

## Default

no shutdown

### 3.19.2.1.2 IGMP commands

## igmp

## Syntax

[no] igmp

## Context

config>router

## Description

This command enables the Internet Group Management Protocol (IGMP) context. When the context is created, the IGMP protocol is enabled.

The Internet Group Management Protocol (IGMP) is used by IPv4 systems (hosts and routers) to report their IP multicast group memberships to neighboring multicast routers. An IP multicast router can be a member of one or more multicast groups, in which case it performs both the "multicast router" part of the protocol, which collects the membership information needed by its multicast routing protocol, and the "group member" part of the protocol, which informs itself and other neighboring multicast routers of its memberships.

The **no** form of the command disables the IGMP instance. To start or suspend execution of IGMP without affecting the configuration, use the **no shutdown** command.

## Default

n/a

## interface

### Syntax

[no] **interface** *ip-int-name*

### Context

config>router>igmp

### Description

This command enables the context to configure an IGMP interface. The interface is a local identifier of the network interface on which reception of the specified multicast address is to be enabled or disabled.

The **no** form of the command deletes the IGMP interface. The **shutdown** command in the **config>router>igmp>interface** context can be used to disable an interface without removing the configuration for the interface.

### Default

no interface (no interfaces are defined)

### Parameters

*ip-int-name*

the IP interface name. Interface names must be unique within the group of defined IP interfaces for **config>router>igmp>interface** and **config>service>ies>interface** commands. An interface name cannot be in the form of an IP address. Interface names can be any string up to 32 characters long composed of printable, 7-bit ASCII characters. If the string contains special characters (such as #, \$, or spaces), the entire string must be enclosed within double quotes.

## disable-router-alert-check

### Syntax

[no] **disable-router-alert-check**

### Context

config>router>igmp>interface

### Description

This command disables or enables router alert checking for IGMP messages received on the interface.

The **no** form of the command enables the IGMP router alert check option.

### Default

no disable-router-alert-check

## import

### Syntax

**import** *policy-name*

**no import**

### Context

config>router>igmp>interface

### Description

This command specifies the import route policy to be used for determining which membership reports are accepted by the router. Route policies are configured in the **config>router>policy-options** context (see the "Route Policies" section in the 7705 SAR Router Configuration Guide).

If an import policy is not specified, all the IGMP reports are accepted.

The **no** form of the command removes the policy association from the IGMP instance.

### Default

no import (no import policy specified)

### Parameters

*policy-name*

the route policy name. Allowed values are any string up to 32 characters long composed of printable, 7-bit ASCII characters. If the string contains special characters (such as #, \$, or spaces), the entire string must be enclosed within double quotes.

## max-groups

### Syntax

**max-groups** *value*

**no max-groups**

### Context

config>router>igmp>interface

### Description

This command specifies the maximum number of groups for which IGMP can have local receiver information based on received IGMP reports on this interface. If this configuration is changed dynamically to a value lower than the currently accepted number of groups, the groups that are already accepted are not deleted. Only new groups will not be allowed.

The **no** version of the command removes the configured value and the maximum number of groups is not defined.

**Default**

no max-groups

**Parameters**

*value*

the maximum number of groups for the interface

**Values** 1 to 256

**max-grp-sources****Syntax**

**max-grp-sources** *value*

**no max-grp-sources**

**Context**

config>router>igmp>interface

**Description**

This command specifies the maximum number of group sources for which IGMP can have local receiver information based on received IGMP reports on this interface. If this configuration is changed dynamically to a value lower than the currently accepted number of group sources, the group sources that are already accepted are not deleted. Only new group sources will not be allowed.

The **no** version of the command removes the configured value and the maximum number of group sources is not defined.

**Default**

no max-grp-sources

**Parameters**

*value*

the maximum number of group sources for the group interface

**Values** 1 to 256

**ssm-translate****Syntax**

**ssm-translate**

**Context**

config>router>igmp

```
config>router>igmp>interface
```

### Description

This command enables the context to configure group ranges that are translated to SSM (S,G) entries. If the static entry needs to be created, it has to be translated from an IGMPv1 or IGMPv2 request to a Source-Specific Multicast (SSM) join message.

## grp-range

### Syntax

```
[no] grp-range start end
```

### Context

```
config>router>igmp>ssm-translate
```

```
config>router>igmp>if>ssm-translate
```

### Description

This command adds or removes SSM translate group range entries. The group range is not created until the **grp-range>source** command is used to configure the source address.

### Default

n/a

### Parameters

*start*

an IP address that specifies the start of the group range

**Values** a.b.c.d

*end*

an IP address that specifies the end of the group range. This value should always be greater than or equal to the *start* value.

**Values** a.b.c.d

## SOURCE

### Syntax

```
[no] source ip-address
```

### Context

```
config>router>igmp>ssm-translate>grp-range
```

```
config>router>igmp>if>ssm-translate>grp-range
```



## Description

This command specifies the source IP address for the group range. Whenever a (\*,G) report is received in the range specified by the **grp-range** *start* and *end* parameters, it is translated to an (S,G) report with the value of this object as the source address.

## Default

n/a

## Parameters

*ip-address*

the unicast IP source address

**Values** a.b.c.d

## static

## Syntax

**static**

## Context

config>router>igmp>interface

## Description

This command allows multicast forwarding out an interface without having received a dynamic join report on that interface. The specific multicast traffic to be forwarded is configured using the **static>group** and **static>group>source** commands.

## Default

n/a

## group

## Syntax

[no] **group** *grp-ip-address*

## Context

config>router>igmp>if>static

## Description

This command adds a static multicast (S,G) group membership to an IPv4 interface. When IGMP static groups are enabled, data is forwarded to an interface without receiving membership reports from host members. A possible use for IGMP static groups is to test multicast forwarding in the absence of an IGMP host receiver.

The **group** command, in combination with the **source** command, is used to create a specific (S,G) static group entry.

### Default

n/a

### Parameters

*grp-ip-address*

specifies an IGMP multicast group address that receives data on an interface. The IP address must be unique for each static group.

**Values** a.b.c.d

## source

### Syntax

[no] **source** *ip-address*

### Context

config>router>igmp>if>static>group

### Description

This command specifies the source IPv4 address (S) for the static IGMP group being configured. Multicast traffic to the group (G) will be forwarded out the interface on which this static group is configured if the source address in the IPv4 header of the multicast packets matches S.

The **source** command, in combination with the **group** command, is used to create a specific (S,G) static group entry.

The **no** form of the command removes the source from the configuration.

### Default

n/a

### Parameters

*ip-address*

the IPv4 unicast address

**Values** a.b.c.d

## subnet-check

### Syntax

[no] **subnet-check**

## Context

```
config>router>igmp>interface
```

## Description

This command enables subnet checking for IGMP messages received on this interface. All IGMP packets with a source address that is not in the local subnet are dropped.

## Default

enabled

## version

## Syntax

```
version version
```

```
no version
```

## Context

```
config>router>igmp>interface
```

## Description

This command specifies the IGMP version. If routers run different versions of IGMP, they will negotiate the lowest common version of IGMP that is supported by hosts on their subnet and operate in that version. For IGMP to function correctly, all routers on a LAN must be configured to run the same version of IGMP on that LAN.

For IGMPv3, a multicast router that is also a group member performs both parts of IGMPv3, receiving and responding to its own IGMP message transmissions as well as those of its neighbors.

## Default

3

## Parameters

*version*

the IGMP version number

**Values** 1, 2, or 3

## query-interval

## Syntax

```
query-interval seconds
```

```
no query-interval
```

## Context

```
config>router>igmp
```

## Description

This command specifies the frequency at which the querying router transmits general host-query messages. Host-query messages solicit group membership information and are sent to the all-systems multicast group address, 224.0.0.1.

## Default

125

## Parameters

*seconds*

the frequency, in seconds, at which the router transmits general host-query messages

**Values** 2 to 1024

## query-last-member-interval

## Syntax

```
query-last-member-interval seconds
```

```
no query-last-member-interval
```

## Context

```
config>router>igmp
```

## Description

This command configures the frequency at which the querying router sends group-specific query messages, including messages sent in response to leave-group messages. The shorter the interval, the faster the detection of the loss of the last member of a group.

## Default

1

## Parameters

*seconds*

the frequency, in seconds, at which query messages are sent

**Values** 1 to 1023

## query-response-interval

### Syntax

**query-response-interval** *seconds*

**no query-response-interval**

### Context

config>router>igmp

### Description

This command specifies how long the querying router waits to receive a response to a host-query message from a host.

### Default

10

### Parameters

*seconds*

the length of time to wait to receive a response to the host-query message from the host

**Values** 1 to 1023

## robust-count

### Syntax

**robust-count** *robust-count*

**no robust-count**

### Context

config>router>igmp

### Description

This command configures the robust count, which is the number of times the router will retry a query. The *robust-count* variable allows tuning for the expected packet loss on a subnet. If a subnet anticipates losses, the *robust-count* variable can be increased.

### Default

2

## Parameters

*robust-count*

the robust count value

**Values** 2 to 10

### 3.19.2.1.3 MLD commands

```
mld
```

#### Syntax

```
[no] mld
```

#### Context

```
config>router
```

#### Description

This command enables the context to configure Multicast Listener Discovery (MLD) parameters. The **no** form of the command disables MLD.

#### Default

```
no mld
```

```
interface
```

#### Syntax

```
[no] interface ip-int-name
```

#### Context

```
config>router>mld
```

#### Description

This command enables the context to configure an MLD interface. The interface is a local identifier of the network interface on which reception of the specified multicast address is to be enabled or disabled.

The **no** form of the command deletes the MLD interface. The **shutdown** command in the **config>router>mld>interface** context can be used to disable an interface without removing the configuration for the interface.

#### Default

```
no interface (no interfaces are defined)
```

## Parameters

*ip-int-name*

the IP interface name. Interface names must be unique within the group of defined IP interfaces for **config>router>interface** and **config>service>ies>interface** commands. An interface name cannot be in the form of an IP address. Interface names can be any string up to 32 characters long composed of printable, 7-bit ASCII characters. If the string contains special characters (such as #, \$, or spaces), the entire string must be enclosed within double quotes.

## disable-router-alert-check

### Syntax

**[no] disable-router-alert-check**

### Context

config>router>mld>interface

### Description

This command enables or disables the router alert checking for MLD messages received on this interface.

The **no** form of the command enables the MLD router alert check option.

### Default

no disable-router-alert-check (enabled)

## import

### Syntax

**import** *policy-name*

**no import**

### Context

config>router>mld>interface

### Description

This command specifies the import route policy to be used for determining which membership reports are accepted by the router. Route policies are configured in the **config>router>policy-options** context.

If an import policy is not specified, all the MLD reports are accepted.

The **no** form of the command removes the policy association from the MLD instance.

### Default

no import (no import policy specified)

## Parameters

*policy-name*

the route policy name. Allowed values are any string up to 32 characters long composed of printable, 7-bit ASCII characters. If the string contains special characters (such as #, \$, or spaces), the entire string must be enclosed within double quotes.

## max-groups

### Syntax

**max-groups** *value*

**no max-groups**

### Context

config>router>mld>interface

### Description

This command specifies the maximum number of groups for which MLD can have local receiver information based on received MLD reports on this interface. If this configuration is changed dynamically to a value lower than the currently accepted number of groups, the groups that are already accepted are not deleted. Only new groups will not be allowed.

The **no** version of the command removes the configured value and the maximum number of groups is not defined.

### Default

no max-groups

### Parameters

*value*

the maximum number of groups for this interface

**Values** 1 to 256

## query-interval

### Syntax

**query-interval** *seconds*

**no query-interval**

### Context

config>router>mld

config>router>mld>interface



## Description

This command specifies the frequency at which the querying router transmits general host-query messages. Host-query messages solicit group membership information and are sent to the all-systems multicast group address, 224.0.0.1.

## Default

125

## Parameters

*seconds*

the frequency, in seconds, at which the router transmits general host-query messages

**Values** 2 to 1024

## query-last-listener-interval

## Syntax

**query-last-listener-interval** *seconds*

**no query-last-listener-interval**

## Context

config>router>mld

config>router>mld>interface

## Description

This command configures the frequency at which the querying router sends group-specific query messages, including messages sent in response to leave-group messages. The shorter the interval, the faster the detection of the loss of the last member of a group.

## Default

1

## Parameters

*seconds*

the frequency, in seconds, at which query messages are sent

**Values** 1 to 1023

## query-response-interval

## Syntax

**query-response-interval** *seconds*

**no query-response-interval****Context**

```
config>router>mld
```

```
config>router>mld>interface
```

**Description**

This command specifies how long the querying router waits to receive a response to a host-query message from a host.

**Default**

10

**Parameters**

*seconds*

the length of time to wait to receive a response to the host-query message from the host

**Values** 1 to 1023

**robust-count****Syntax**

```
robust-count robust-count
```

```
no robust-count
```

**Context**

```
config>router>mld
```

**Description**

This command configures the robust count. The *robust-count* variable allows tuning for the expected packet loss on a subnet. If a subnet anticipates losses, the *robust-count* variable can be increased.

**Default**

2

**Parameters**

*robust-count*

the robust count value

**Values** 2 to 10

## ssm-translate

### Syntax

```
ssm-translate
```

### Context

```
config>router>mld
```

```
config>router>mld>interface
```

### Description

This command enables the context to configure group ranges that are translated to SSM (S,G) entries. If the static entry needs to be created, it has to be translated from an MLDv1 request to a Source-Specific Multicast (SSM) join message.

## grp-range

### Syntax

```
[no] grp-range start end
```

### Context

```
config>router>mld>ssm-translate
```

```
config>router>mld>if>ssm-translate
```

### Description

This command is used to configure group ranges that are translated to SSM (S,G) entries.

### Default

n/a

### Parameters

*start*

a valid multicast group IPv6 address that identifies the start of the group range

*end*

an IPv6 address that specifies the end of the group range. This value should always be greater than or equal to the *start* value.

## SOURCE

### Syntax

```
[no] source src-ipv6-address
```

## Context

```
config>router>mld>ssm-translate>grp-range  
config>router>mld>if>ssm-translate>grp-range
```

## Description

This command specifies the source IPv6 address for the group range. Whenever a (\*,G) report is received in the range specified by **grp-range** *start* and *end* parameters, it is translated to an (S,G) report with the value of this object as the source address.

## Default

n/a

## Parameters

*src-ipv6-address*  
the IPv6 address that will be sending data

static

## Syntax

**static**

## Context

```
config>router>mld>interface
```

## Description

This command allows multicast forwarding out an interface without having received a dynamic join report on that interface. The specific multicast traffic to be forwarded is configured using the **static>group** and **static>group>source** commands.

## Default

n/a

group

## Syntax

**[no] group** *grp-ipv6-address*

## Context

```
config>router>mld>if>static
```

## Description

This command adds a static multicast (S,G) group membership to an IPv6 interface. When MLD static groups are enabled, data is forwarded to an interface without receiving membership reports from host members. A possible use for MLD static groups is to test multicast forwarding in the absence of an MLD host receiver.

The **no** form of the command removes the IPv6 address from the configuration.

## Default

n/a

## Parameters

*grp-ipv6-address*

specifies an MLD multicast group address that receives data on an interface. The IPv6 address must be unique for each static group.

## SOURCE

## Syntax

[no] **source** *src-ipv6-address*

## Context

config>router>mld>if>static>group

## Description

This command specifies the source IPv6 address (S) for the static MLD group being configured. Multicast traffic to the group (G) will be forwarded out the interface on which this static group is configured if the source address in the IPv6 header of the multicast packets matches S.

The **source** command, in combination with the **group** command, is used to create a specific (S,G) static group entry.

The **no** form of the command removes the source from the configuration.

## Default

n/a

## Parameters

*src-ipv6-address*

the IPv6 unicast address

## version

## Syntax

**version** *version*

**no version****Context**

```
config>router>mld>interface
```

**Description**

This command specifies the MLD version. If routers run different versions of MLD, they will negotiate the lowest common version of MLD that is supported by hosts on their subnet and operate in that version. For MLD to function correctly, all routers on a LAN must be configured to run the same version of MLD on that LAN.

**Default**

2

**Parameters**

*version*

the MLD version number

**Values** 1 or 2

### 3.19.2.1.4 PIM commands

**pim****Syntax**

```
[no] pim
```

**Context**

```
config>router
```

**Description**

This command configures a Protocol Independent Multicast (PIM) instance.

PIM is used for multicast routing within the network. Devices in the network can receive the multicast feed requested and non-participating routers can be pruned. The 7705 SAR supports PIM source-specific multicast (SSM) and PIM sparse mode (SM).

The **no** form of the command deletes the PIM instance and removes all configuration parameters.

**Default**

no pim

## apply-to

### Syntax

```
apply-to {ies | non-ies | all | none}
```

### Context

```
config>router>pim
```

### Description

This command automatically creates or removes PIM interfaces. The **ies**, **non-ies**, and **all** options create a PIM interface with default PIM parameters when a new IP or IES interface is created manually. The **none** option removes any automatically created PIM interfaces that have not been modified manually in the PIM context. Existing manually created or modified PIM interfaces are not affected.

The default option for the **apply-to** command is **none**, so to activate its automatic behavior it must first be saved in the PIM configuration structure. Then, all subsequent commands either create new structures (in the case of IP or IES interface commands) or modify the default values created by the **apply-to** command (in the case of PIM interface commands).

For example, assume that the **apply-to** setting is **none** and that two manually created PIM interfaces already exist. If the **apply-to** setting is changed to **ies**, then the two manually created PIM interfaces remain unchanged but any newly created or modified IES interfaces will automatically create a corresponding PIM interface with default PIM values. Subsequently, if the **apply-to** command is changed back to **none**, then all PIM interfaces that were not manually created or modified are removed.

If a manually created or modified PIM interface is deleted, the interface will be recreated when (re)processing the **apply-to** command. If PIM is not required on a specific interface, then a **config>router>pim>if>shutdown** command should be executed.

### Default

none (keyword)

### Parameters

#### ies

automatically creates a PIM interface for all IES interfaces in PIM

#### non-ies

creates non-IES interfaces in PIM

#### all

creates all IES and non-IES interfaces in PIM

#### none

removes all PIM interfaces that have not been manually created or modified in the PIM context

## import

### Syntax

```
import {join-policy | register-policy} [policy-name [.. policy-name (up to 5 max)]]  
no import {join-policy | register-policy}
```

### Context

```
config>router>pim
```

### Description

This command specifies the import route policy to be used by PIM. Route policies are configured in the **config>router>policy-options** context. Up to five import policy names can be specified.

If an import policy is not specified, IGP routes are accepted by default.

The **no** form of the command removes the policy association from the instance.

### Default

```
no import join-policy  
no import register-policy
```

### Parameters

#### **join-policy**

this keyword filters PIM join messages, which prevents unwanted multicast streams from traversing the network

#### **register-policy**

this keyword filters PIM register messages. PIM register filters prevent register messages from being processed by the RP. This filter can only be defined on an RP. When a match is found, the RP immediately sends back a register-stop message.

#### *policy-name*

the route policy name

## interface

### Syntax

```
[no] interface ip-int-name
```

### Context

```
config>router>pim
```

### Description

This command creates a logical IP routing interface.



The **no** form of the command removes the IP interface and all the associated configurations.

### Default

no interfaces or names are defined within PIM

### Parameters

*ip-int-name*

the name of the IP interface. If the string contains special characters (such as #, \$, or spaces), the entire string must be enclosed within double quotes.

If the *ip-int-name* already exists, the context is changed to maintain that IP interface. If *ip-int-name* does not exist, the interface is created and the context is changed to that interface for further command processing.

**Values** 1 to 32 alphanumeric characters

## assert-period

### Syntax

**assert-period** *assert-period*

**no assert-period**

### Context

config>router>pim>interface

### Description

This command configures the period for refreshes of PIM Assert messages on an interface.

The **no** form of the command removes the assert period from the configuration.

### Default

no assert-period

### Parameters

*assert-period*

the period for refreshes of PIM Assert messages on an interface

**Values** 1 to 300 seconds

## bfd-enable

### Syntax

**[no] bfd-enable** [ipv4 | ipv6]

## Context

```
config>router>pim>interface
```

## Description

This command enables the use of IPv4 or IPv6 Bidirectional Forwarding Detection (BFD) to control the state of the associated protocol interface. By enabling BFD on a given protocol interface, the state of the protocol interface is tied to the state of the BFD session between the local node and the remote node. The parameters used for BFD are set via the BFD command under the IP interface.

The **no** form of this command removes BFD from the associated IGP protocol adjacency.

## Default

```
no bfd-enable
```

## bsm-check-rtr-alert

## Syntax

```
[no] bsm-check-rtr-alert
```

## Context

```
config>router>pim>interface
```

## Description

This command enables the checking of the router alert option in the bootstrap messages received on this interface.

## Default

```
no bsm-check-rtr-alert
```

## hello-interval

## Syntax

```
hello-interval hello-interval  
no hello-interval
```

## Context

```
config>router>pim>interface
```

## Description

This command configures the time interval between PIM Hello messages transmitted on this interface.

The **no** form of this command reverts to the default value of the **hello-interval**.

**Default**

30

**Parameters***hello-interval*

the hello interval in seconds. A 0 (zero) value disables the sending of Hello messages (the PIM neighbor will never time out the adjacency)

**Values** 0 to 255 seconds

**hello-multiplier****Syntax****hello-multiplier** *deci-units***no hello-multiplier****Context**

config&gt;router&gt;pim&gt;interface

**Description**

This command configures the multiplier used to determine the hold time for a PIM neighbor on this interface.

The **hello-multiplier** in conjunction with the **hello-interval** determines the hold time for a PIM neighbor.

The multiplier value is expressed in *deci-units*, so that (for example) 10 deci-units represents a multiplier of 1 and 35 deci-units represents a multiplier of 3.5.

For example, if the **hello-interval** is 1 s and the **hello-multiplier** is 35 deci-units, then the calculated hold time (in seconds) is:

$$\begin{aligned} \text{hold time} &= (\text{hello-interval} * \text{hello-multiplier}) / 10 \\ &= (1 \text{ s} * 35 \text{ deci-units}) / 10 \\ &= 3.5 \text{ s} \end{aligned}$$

**Parameters***deci-units*

the value, specified in multiples of 0.1, for the formula (above) used to calculate the hold time based on the **hello-multiplier**

This allows the PIM default timeout of 3.5 seconds to be supported.

**Values** 20 to 100

**Default** 35

## instant-prune-echo

### Syntax

[no] instant-prune-echo

### Context

config>router>pim>interface

### Description

This command enables or disables instant PruneEcho for a PIM interface.

### Default

no instant-prune-echo

## ipv4-multicast-disable

### Syntax

[no] ipv4-multicast-disable

### Context

config>router>pim

config>router>pim>interface

### Description

This command administratively disables or enables PIM operation for IPv4.

### Default

no ipv4-multicast-disable

## ipv6-multicast-disable

### Syntax

[no] ipv6-multicast-disable

### Context

config>router>pim

config>router>pim>interface

### Description

This command administratively disables or enables PIM operation for IPv6.

## Default

no ipv6-multicast-disable

## max-groups

## Syntax

**max-groups** *value*

**no max-groups**

## Context

config>router>pim>interface

## Description

This command specifies the maximum number of groups for which PIM can have local receiver information based on received PIM reports on this interface. If this configuration is changed dynamically to a value lower than the currently accepted number of groups, the groups that are already accepted are not deleted. Only new groups will not be allowed. This command is applicable for IPv4 and IPv6.

The **no** version of the command removes the configured value and the maximum number of groups is not defined.

## Default

no max-groups

## Parameters

*value*

the maximum number of groups for this interface

**Values** 1 to 256

## multicast-senders

## Syntax

**multicast-senders** {**auto** | **always** | **never**}

**no multicast-senders**

## Context

config>router>pim>interface

## Description

This command configures how traffic from directly attached multicast sources should be treated on broadcast interfaces. It can also be used to treat all traffic received on an interface as traffic coming from a

directly attached multicast source. This is particularly useful if a multicast source is connected to a point-to-point or unnumbered interface.

## Default

auto

## Parameters

### auto

specifies that, on broadcast interfaces, the forwarding plane performs a subnet-match check on multicast packets received on the interface to determine if the packet is from a directly attached source. On unnumbered or point-to-point interfaces, all traffic is implicitly treated as coming from a remote source.

### always

treats all traffic received on the interface as coming from a directly attached multicast source

### never

specifies that, on broadcast interfaces, traffic from directly attached multicast sources will not be forwarded; however, traffic from a remote source will still be forwarded if there is a multicast state for it. On unnumbered or point-to-point interfaces, it means that all traffic received on that interface must not be forwarded.

## multicast-to-multicast

## Syntax

**multicast-to-multicast source** *ip-address* **group-start** *ip-address* **group-end** *ip-address* **to-multicast** *group-address*

**no multicast-to-multicast**

## Context

config>router>pim>interface

## Description

This command enables multicast-to-multicast address translation by mapping a range of source IP addresses to a range of multicast group addresses. The PIM interface on the 7705 SAR translator router is the source of the multicast address. Multiple (S,G)s (for example, s1,g1 / s2,g1 / s3,g1) can be mapped to a single PIM interface, using the same source IP address for the translated (S,G) but for a range of groups.

The PIM interface on the translator router must first be enabled for multicast translation with the **config>router>interface>multicast-translation** command.

## Default

no multicast-to-multicast

## Parameters

**source** *ip-address*

the source address of the (S,G) being translated

**group-start** *ip-address*

the starting group address of the (S,G) being translated

**group-end** *ip-address*

the ending group address of the (S,G) being translated

*group-address*

the multicast group address used for translation

## priority

### Syntax

**priority** *dr-priority*

**no priority**

### Context

config>router>pim>interface

### Description

This command sets the priority value that is used to elect the designated router (DR). The DR election priority is a 32-bit unsigned number and the router with numerically largest *dr-priority* value is always the preferred DR.

The **no** form of the command restores the default values.

### Default

1

### Parameters

*dr-priority*

the priority value that is used to elect the DR. The higher the value, the higher the priority.

**Values** 1 to 4294967295

## sticky-dr

### Syntax

**sticky-dr** [**priority** *dr-priority*]

**no sticky-dr**

## Context

```
config>router>pim>interface
```

## Description

This command enables **sticky-dr** operation on this interface. When enabled, the priority in PIM Hello messages sent on this interface when elected as the designated router (DR) will be modified to the value configured in *dr-priority*. This is done to avoid the delays in forwarding caused by DR recovery, when switching back to the old DR on a LAN when it comes back up.

By enabling **sticky-dr** on this interface, it will continue to act as the DR for the LAN even after the old DR comes back up.

The **no** form of the command disables **sticky-dr** operation on this interface.

## Default

```
no sticky-dr (disabled)
```

## Parameters

**priority** *dr-priority*

sets the DR priority to be sent in PIM Hello messages following the election of that interface as the DR, when **sticky-dr** operation is enabled

**Values** 1 to 4294967295

## three-way-hello

## Syntax

```
[no] three-way-hello
```

## Context

```
config>router>pim>interface
```

## Description

This command enables three-way hello. By default, three-way hello is disabled on all interfaces and the standard two-way hello is supported.

## Default

```
no three-way-hello
```

## tracking-support

## Syntax

```
[no] tracking-support
```



## Context

```
config>router>pim>interface
```

## Description

This command sets the T-bit in the LAN Prune Delay option of the Hello Message. This indicates the router's capability to enable join message suppression. This capability allows for upstream routers to explicitly track Join memberships.

## Default

```
no tracking-support
```

## unicast-to-multicast

## Syntax

```
unicast-to-multicast unicast-start ip-address unicast-end ip-address destination ip-address to-multicast ip-address
```

```
no unicast-to-multicast
```

## Context

```
config>router>pim>interface
```

## Description

This command enables unicast-to-multicast address translation by mapping a range of unicast source addresses and a unicast destination address to a multicast group address. The unicast destination address is a loopback IP address configured on the 7705 SAR that is performing the translation. This translator router becomes the source of the multicast packets. The multicast source address is a loopback interface IP address configured on the PIM interface of the translator router. The PIM interface on the 7705 SAR translator router must first be enabled for multicast translation with the **config>router>interface>multicast-translation** command.

The unicast destination and the multicast source can be the same loopback address or different loopback addresses.

The translation can map a range of unicast source addresses to a range of multicast group addresses. For example, if the unicast source address range is 1.1.1.1 to 1.1.1.4 and the multicast group address is 230.0.0.100, the following multicast destination address range is created:

*Table 5: Multicast destination address range*

Unicast source	Multicast group
1.1.1.1	230.0.0.100
1.1.1.2	230.0.0.101
1.1.1.3	230.0.0.102
1.1.1.4	230.0.0.103

## Default

no unicast-to-multicast

## Parameters

**unicast-start** *ip-address*

the start of the range of unicast source addresses to be translated

**unicast-end** *ip-address*

the end of the range of unicast source addresses to be translated

**destination** *ip-address*

the destination address of the unicast stream being translated

**multicast** *ip-address*

the group and destination addresses for the multicast stream

## non-dr-attract-traffic

## Syntax

[no] non-dr-attract-traffic

## Context

config>router>pim

## Description

This command specifies whether the router should ignore the designated router state and attract traffic even when it is not the designated router.

An operator can configure an interface (router or IES) to IGMP for PIM. The interface IGMP state will be synchronized to the backup node if it is associated with the redundant peer port. The interface can be configured to use PIM, which will cause multicast streams to be sent to the elected DR only. The DR will also be the router sending traffic to the DSLAM. Since it may be required to attract traffic to both routers, a **non-dr-attract-traffic** flag can be used in the PIM context to have the router ignore the DR state and attract traffic if it is not the DR. While using this flag, the router may not send the stream down to the DSLAM while it is not the DR.

When enabled, the designated router state is ignored. When disabled, the designated router value is honored.

## Default

no non-dr-attract-traffic

## rp

## Syntax

rp

## Context

```
config>router>pim
```

## Description

This command provides access to the bootstrap import and export policy commands.

The 7705 SAR handles Register messages by allowing the configuration of policies that will drop incoming Register messages silently or send register-stop messages if the policy action is set to "accept" or if no policy action is assigned.

## anycast

## Syntax

```
[no] anycast rp-ip-address
```

## Context

```
config>router>pim>rp
```

## Description

This command configures a PIM anycast protocol instance for the RP being configured. Anycast enables fast convergence when a PIM RP router fails by allowing receivers and sources to rendezvous at the closest RP.

The **no** form of the command removes the anycast instance from the configuration.

## Default

n/a

## Parameters

*rp-ip-address*

specifies the loopback IP address shared by all routes that form the RP set for this anycast instance. Only a single address can be configured. If another **anycast** command is entered with an address, the old address is replaced with the new address. If no IP address is entered, the command is used to enter the anycast CLI level.

**Values** any valid loopback address configured on the node

## rp-set-peer

## Syntax

```
[no] rp-set-peer ip-address
```

## Context

```
config>router>pim>rp>anycast
```

## Description

This command configures a peer in the anycast-RP set. The *ip-address* identifies the address used by the other node as the RP candidate address for the same multicast group address range as configured on this node.



**Caution:** This is a manual procedure. Caution should be taken to produce a consistent configuration of an RP set for a multicast group address range. The priority should be identical on each node and be a higher value than any other configured RP candidate that is not a member of this RP set.

Although there is no set maximum number of addresses that can be configured in an RP set, a maximum of 15 IP addresses is recommended.

The **no** form of the command removes an entry from the list.

## Default

n/a

## Parameters

*ip-address*

specifies a peer in the anycast-RP set

**Values** any valid *ip-address* within the scope outlined above

## auto-rp-discovery

### Syntax

[no] **auto-rp-discovery**

### Context

config>router>pim>rp

### Description

This command enables auto-RP protocol in discovery mode. In discovery mode, RP-mapping and RP-candidate messages are received and forwarded to downstream nodes. RP-mapping messages are received locally to learn about the availability of RP nodes present in the network.

Either **bsr-candidate** for IPv4 or **auto-rp-discovery** can be configured; the two mechanisms cannot be enabled together.

The **no** form of the command disables auto-RP discovery.

### Default

no auto-rp-discovery

## bootstrap-export

### Syntax

**bootstrap-export** *policy-name* [*..policy-name* (up to 5 max)]

**no bootstrap-export**

### Context

config>router>pim>rp

### Description

This command applies export policies to the PIM configuration. The policies control the flow of bootstrap messages from the RP. Up to five policy names can be specified.

Bootstrap export policies are created using the **config>router>policy-options>policy-statement** command. For more information about configuring bootstrap policies, see the "Configuring Bootstrap Message Import and Export Policies" section of the 7705 SAR Router Configuration Guide.

### Default

no bootstrap-export

### Parameters

*policy-name*

the export policy name up

## bootstrap-import

### Syntax

**bootstrap-import** *policy-name* [*..policy-name* (up to 5 max)]

**no bootstrap-import**

### Context

config>router>pim>rp

### Description

This command applies import policies to the PIM configuration. The policies control the flow of bootstrap messages to the RP. Up to five policy names can be specified.

Bootstrap import policies are created using the **config>router>policy-options>policy-statement** command. For more information about configuring bootstrap policies, see the "Configuring Bootstrap Message Import and Export Policies" section of the 7705 SAR Router Configuration Guide.

### Default

no bootstrap-import

## Parameters

*policy-name*

the import policy name

## bsr-candidate

### Syntax

**bsr-candidate**

### Context

config>router>pim>rp

### Description

This command enables the context to configure candidate bootstrap router (BSR) parameters.

Either **bsr-candidate** for IPv4 or **auto-rp-discovery** can be configured; the two mechanisms cannot be enabled together.

### Default

bsr-candidate shutdown

## address

### Syntax

**address** *ip-address*

### Context

config>router>pim>rp>bsr-candidate

### Description

This command is used to configure the candidate BSR IP address. This address is for bootstrap router election.

### Default

n/a

## Parameters

*ip-address*

specifies the IP host address that will be used by the IP interface within the subnet. This address must be a unique unicast address within the subnet and specified in dotted-decimal notation (1.0.0.0 to 223.255.255.255).

**Values** a.b.c.d

## hash-mask-len

### Syntax

**hash-mask-len** *hash-mask-length*

**no hash-mask-len**

### Context

config>router>pim>rp>bsr-candidate

### Description

This command is used to configure the length of the mask that is combined with the group address before the hash function is called. All groups with the same hash result will map to the same RP. For example, if the *hash-mask-length* value is 24, only the first 24 bits of the group addresses matter. This mechanism is used to map one group or multiple groups to an RP.

### Parameters

*hash-mask-length*

specifies the hash mask length

**Values** 0 to 32

## priority

### Syntax

**priority** *bootstrap-priority*

**no priority**

### Context

config>router>pim>rp>bsr-candidate

### Description

This command configures the bootstrap priority of the router. The RP is sometimes called the bootstrap router. The priority determines if the router is eligible to be a bootstrap router. In the case of a tie, the router with the highest IP address is elected to be the bootstrap router.

### Default

0

## Parameters

### *bootstrap-priority*

specifies the priority to become the bootstrap router. The higher the value, the higher the priority. A value of 0 means the router is not eligible to be the bootstrap router. A value of 1 means router is the least likely to become the designated router.

**Values** 0 to 255

## rp-candidate

### Syntax

**rp-candidate**

### Context

config>router>pim>rp

### Description

This command enables the context to configure the candidate rendezvous point (RP) parameters.

Routers use a set of available rendezvous points distributed in bootstrap messages to get the proper group-to-RP mapping. A set of routers within a domain are also configured as candidate RPs; typically, these will be the same routers that are configured as candidate BSRs.

Every multicast group has a shared tree through which receivers learn about new multicast sources and new receivers learn about all multicast sources. The RP is the root of this shared tree.

### Default

shutdown

## address

### Syntax

**address** *ip-address*

**no address**

### Context

config>router>pim>rp>rp-candidate

### Description

This command configures the local RP address. This address is sent in the RP candidate advertisements to the bootstrap router.

### Default

n/a



## Parameters

*ip-address*

specifies the *ip-address* of the RP

**Values** 1.0.0.0 to 223.255.255.255

## group-range

### Syntax

[no] **group-range** {*grp-ip-address/mask* | *grp-ip-address netmask*}

### Context

config>router>pim>rp>rp-candidate

### Description

This command configures a range of addresses for the RP candidate group.

### Default

n/a

## Parameters

*grp-ip-address*

specifies the multicast group IP address expressed in dotted-decimal notation (224.0.0.0 to 239.255.255.255)

**Values** a.b.c.d (multicast group address)

*mask*

specifies the mask associated with the IP prefix expressed as a mask length or in dotted-decimal notation; for example /16 for a sixteen-bit mask. The mask can also be entered in dotted-decimal notation (255.255.0.0).

**Values** 4 to 32

*netmask*

specifies the subnet mask in dotted-decimal notation (0.0.0.0 to 255.255.255.255)

**Values** a.b.c.d (network bits all 1 and host bits all 0)

## holdtime

### Syntax

**holdtime** *holdtime*

**no holdtime**

## Context

```
config>router>pim>rp>rp-candidate
```

## Description

This command configures the length of time, in seconds, that neighbors should consider the sending router to be operationally up. A local RP cannot be configured on a logical router.

## Parameters

*holdtime*

specifies the hold time, in seconds

**Default** 150

**Values** 5 to 255

## priority

## Syntax

**priority** *priority*

**no priority**

## Context

```
config>router>pim>rp>rp-candidate
```

## Description

This command configures the candidate RP priority for becoming a rendezvous point (RP). This value is used to elect the RP for a group range.

## Default

192

## Parameters

*priority*

specifies the priority to become a rendezvous point (RP). A value of 0 is considered as the highest priority.

**Default** 192

**Values** 0 to 255

## static

### Syntax

**static**

### Context

config>router>pim>rp

### Description

This command enables the context to configure static rendezvous point (RP) addresses for a multicast group range.

Entries can be created or destroyed. If no IP addresses are configured in the **config>router>pim>rp>static>address** context, then the multicast group-to-RP mapping is derived from the RP-set messages received from the bootstrap router.

## address

### Syntax

**address** *ip-address*

**no address**

### Context

config>router>pim>rp>static

### Description

This command indicates the rendezvous point (RP) address that is used by the router for the range of multicast groups configured by the range command.

### Default

n/a

### Parameters

*ip-address*

specifies the IP host address that will be used by the IP interface within the subnet. This address must be a unique unicast address within the subnet and specified in dotted-decimal notation (1.0.0.0 to 223.255.255.255).

**Values** a.b.c.d

## group-prefix

### Syntax

[no] **group-prefix** {*grp-ip-address/mask* | *grp-ip-address netmask*}

### Context

config>router>pim>rp>static>address

### Description

The command defines a range of multicast IP addresses for which an RP is applicable.

The **no** form of the command removes the address range.

### Default

n/a

### Parameters

*grp-ip-address*

specifies the multicast IP address

**Values** a.b.c.d (multicast group address)

*mask*

specifies the mask of the multicast IP address

**Values** 4 to 32

*netmask*

specifies the subnet mask in dotted-decimal notation

**Values** a.b.c.d (network bits all 1 and host bits all 0)

## override

### Syntax

[no] **override**

### Context

config>router>pim>rp>static>address

### Description

This command changes the precedence of static RP over dynamically learned RP.

When enabled, the static group-to-RP mappings take precedence over the dynamically learned mappings.

## Default

no override

## rpf-table

## Syntax

**rpf-table** {**rtable-m** | **rtable-u** | **both**}

**no rpf-table**

## Context

config>router>pim

## Description

This command configures the sequence of route tables used to find a Reverse Path Forwarding (RPF) interface for a particular multicast route.

By default, only the unicast route table is looked up to calculate the RPF interface toward the source/rendezvous point. However the operator can specify the following:

- use unicast route table only
- use multicast route table only
- use both route tables

## Default

rtable-u

## Parameters

### rtable-m

specifies that only the multicast route table will be used by the multicast protocol (PIM) for IPv4 RPF checks. This route table will contain routes submitted by static routes, IS-IS and OSPF.

### rtable-u

specifies that only the unicast route table will be used by the multicast protocol (PIM) for IPv4 RPF checks. This route table will contain routes submitted by all the unicast routing protocols.

### both

specifies that PIM will always use the multicast route table first, and if there is a route, it will use it. If PIM does not find a route in the first lookup, it will try to find it in the unicast route table.

## rpf6-table

### Syntax

**rpf6-table** {*rtable6-m* | *rtable6-u* | *both*}

**no rpf6-table**

### Context

config>router>pim

### Description

This command configures the sequence of route tables used to find a Reverse Path Forwarding (RPF) interface for a particular multicast route.

By default, only the unicast route table is looked up to calculate the RPF interface toward the source/rendezvous point. However the operator can specify the following:

- use unicast route table only
- use multicast route table only
- use both route tables

### Default

*rtable6-u*

### Parameters

#### **rtable6-m**

specifies that only the multicast route table will be used by the multicast protocol (PIM) for IPv6 RPF checks. This route table will contain routes submitted by static routes and OSPF.

#### **rtable6-u**

specifies that only the unicast route table will be used by the multicast protocol (PIM) for IPv6 RPF checks. This route table will contain routes submitted by all the unicast routing protocols.

#### **both**

specifies that PIM will always use the multicast route table first, and if there is a route, it will use it. If PIM does not find a route in the first lookup, it will try to find it in the unicast route table.

## spt-switchover-threshold

### Syntax

**spt-switchover-threshold** {*grp-ipv4-prefix**ipv4-prefix-length* | *grp-ipv4-prefix netmask* | *grp-ipv6-prefix**ipv6-prefix-length*} *spt-threshold*

**no spt-switchover-threshold** {*grp-ipv4-prefix**ipv4-prefix-length* | *grp-ipv4-prefix netmask* | *grp-ipv6-prefix**ipv6-prefix-length*}

## Context

```
config>router>pim
```

## Description

This command configures the shortest path tree (SPT) switchover thresholds for group prefixes.

PIM-SM routers with directly connected routers receive multicast traffic initially on a shared tree rooted at the RP. When the traffic arrives on the shared tree and the source of the traffic is known, a switchover to the SPT rooted at the source is attempted.

For a group that falls in the range of a prefix configured in the table, the corresponding threshold value determines when the router should switch over from the shared tree to the source-specific tree. The switchover is attempted only if the traffic rate on the shared tree for the group exceeds the configured threshold.

If there is no matching prefix in the table, the default behavior is to switch over when the first packet is seen. If there are multiple prefixes matching a group, the most specific entry is used.

## Default

n/a

## Parameters

*grp-ipv4-prefix*

specifies the group IPv4 multicast address in dotted-decimal notation

*ipv4-prefix-length*

specifies the length of the IPv4 prefix

*netmask*

specifies the netmask associated with the IPv4 prefix, expressed in dotted-decimal notation. Network bits must be 1, and host bits must be 0.

*grp-ipv6-prefix*

specifies the group IPv6 multicast address in hexadecimal notation

*ipv6-prefix-length*

specifies the length of the IPv6 prefix

*spt-threshold*

specifies the configured threshold in kilobits per second (kbps) for a group prefix. A switchover is attempted only if the traffic rate on the shared tree for the group exceeds this configured threshold. When the **infinity** keyword is specified, no switchover will occur at any time, regardless of the traffic level detected.

**Values** 1 to 4294967294 | infinity (threshold in kbps)

## ssm-default-range-disable

## Syntax

```
[no] ssm-default-range-disable ipv4
```

**[no] ssm-default-range-disable ipv6****Context**

```
config>router>pim
```

**Description**

This command enables and disables the IPv4 and IPv6 SSM default ranges.

**Default**

```
no ssm-default-range-disable ipv4 no ssm-default-range-disable ipv6
```

**Parameters****ipv4**

specifies IPv4 as the SSM default range

**ipv6**

specifies IPv6 as the SSM default range

**ssm-groups****Syntax**

```
[no] ssm-groups
```

**Context**

```
config>router>pim
```

**Description**

This command enables the context to configure an SSM group range.

**group-range****Syntax**

```
[no] group-range {ip-prefix/mask | ip-prefix netmask}
```

**Context**

```
config>router>pim>ssm-groups
```

**Description**

This command configures the address ranges of the multicast groups for this router. When there are parameters present, the command configures the SSM group ranges for IPv6 addresses and netmasks.

**Default**

```
n/a
```



## Parameters

*ip-prefix/mask*

specifies the IP prefix for the range used by the ABR to advertise that summarizes the area into another area

*netmask*

specifies the subnet mask in dotted-decimal notation

### 3.19.2.1.5 MSDP commands

```
msdp
```

#### Syntax

```
[no] msdp
```

#### Context

```
config>router
```

#### Description

This command enables a Multicast Source Discovery Protocol (MSDP) instance. When an MSDP instance is created, the protocol is enabled. To start or suspend execution of the MSDP protocol without affecting the configuration, use the **[no] shutdown** command.

For MSDP to function, at least one peer must be configured.

When MSDP is configured and started, an event message is generated.

Before the **no** form of the command is executed, all sessions are terminated and an event message is generated.

When all peering sessions are terminated, event messages are not generated for each peer.

The **no** form of the command deletes the MSDP instance, removing all associated configuration parameters.

#### Default

```
no msdp
```

```
active-source-limit
```

#### Syntax

```
active-source-limit number
```

```
no active-source-limit
```

#### Context

```
config>router>msdp
```

```
config>router>msdp>group
config>router>msdp>group>peer
config>router>msdp>peer
config>router>msdp>source
```

### Description

This command controls the maximum number of source-active (SA) messages that will be accepted by MSDP, which controls the number of active sources that can be stored on the system.

The **no** form of this command resets the SA message limit to its default operation.

### Default

no active-source-limit

### Parameters

*number*

defines how many active sources can be maintained by MSDP

**Values** 0 to 1000000

## data-encapsulation

### Syntax

[no] data-encapsulation

### Context

config>router>msdp

### Description

This command configures a rendezvous point (RP) that uses MSDP to encapsulate multicast data received in MSDP register messages inside forwarded MSDP SA messages.

### Default

data-encapsulation

## export

### Syntax

**export** *policy-name* [*policy-name...*(up to 5 max)]

**no export**

## Context

```
config>router>msdp
config>router>msdp>peer
config>router>msdp>group
config>router>msdp>group>peer
```

## Description

This command specifies the policies to export the SA state from the SA list into MSDP.

If multiple policy names are specified, the policies are evaluated in the order they are specified. A maximum of five policy names can be specified. The first policy that matches is applied. If multiple export commands are issued, the last command entered will override the previous command.

If you configure an export policy at the global level, each individual peer inherits the global policy. If you configure an export policy at the group level, each individual peer in a group inherits the group's policy. If you configure an export policy at the peer level, the policy only applies to the peer where it is configured.

The **no** form of the command removes all policies from the configuration and all SA entries are allowed.

## Default

no export

## Parameters

*policy-name*

specifies the export policy name. Up to five policy names can be specified.

## group

## Syntax

```
[no] group group-name
```

## Context

```
config>router>msdp
```

## Description

This command enables access to the context to create or modify an MSDP group. To configure multiple MSDP groups, multiple group statements must be included in the configuration.

By default, the group's parameter settings are inherited from the global MSDP parameter settings. To override the global settings, group-specific settings within the group can be configured.

If the specified group name is already configured, this command enables the context to configure or modify group-specific parameters.

If the specified group name is not already configured, this command creates the group and enables the context to configure the group-specific parameters.

For a group to be functional, at least one peer must be configured.

**Default**

no group

**Parameters**

*group-name*

specifies a unique name for the MSDP group

**import****Syntax**

**import** *policy-name* [*policy-name...*(up to 5 max)]

**no import**

**Context**

config>router>msdp

config>router>msdp>peer

config>router>msdp>group

config>router>msdp>group>peer

**Description**

This command specifies the policies to import the SA state from MSDP into the SA list.

If multiple policy names are specified, the policies are evaluated in the order they are specified. A maximum of five policy names can be specified. The first policy that matches is applied. If multiple import commands are issued, the last command entered will override the previous command.

If you configure an import policy at the global level, each individual peer inherits the global policy.

If you configure an import policy at the group level, each individual peer in a group inherits the group's policy.

If you configure an import policy at the peer level, the policy only applies to the peer where it is configured.

The **no** form of the command removes all policies from the configuration and all SA messages are allowed.

**Default**

no import

**Parameters**

*policy-name*

specifies the import policy name. Up to five policy names can be specified.

## local-address

### Syntax

**local-address** *address*

**no local-address**

### Context

```
config>router>msdp
```

```
config>router>msdp>peer
```

```
config>router>msdp>group
```

```
config>router>msdp>group>peer
```

### Description

This command configures the local end of an MSDP session. For MSDP to function, at least one peer must be configured. When configuring a peer, you must include this **local-address** command. This address must be present on the node and is used to validate incoming connections to the peer and to establish connections to the remote peer.

When the address is configured, it is validated and will be used as the local address for MSDP peers from that point. If a subsequent **local-address** command is entered, it will replace the existing configuration and existing sessions will be terminated.

Similarly, when the **no** form of this command is entered, the existing **local-address** will be removed from the configuration and the existing sessions will be terminated.

Whenever a session is terminated, all information pertaining to and learned from that peer will be removed.

Whenever a new peering session is created or a peering session is lost, an event message is generated.

The **no** form of this command removes the **local-address** from the configuration.

### Default

no local-address

### Parameters

*address*

specifies an existing address on the node

## mode

### Syntax

**mode** {**mesh-group** | **standard**}

### Context

```
config>router>msdp>group
```

## Description

This command configures groups of peers either in non-meshed mode or in a full mesh topology to limit excessive flooding of SA messages to neighboring peers. When the mode is specified as **mesh-group**, SA messages received from a mesh group member are always accepted but are not flooded to other members of the same mesh group. These SA messages are only flooded to non-mesh-group peers or members of other mesh groups

In a meshed configuration, all members of the group must have a peer connection with every other mesh group member. If this rule is not adhered to, unpredictable results may occur.

## Default

standard

## Parameters

### **mesh-group**

specifies that all members of the group have full mesh MSDP connectivity with each other

### **standard**

specifies a non-meshed mode

## peer

## Syntax

[no] **peer** *peer-address*

## Context

config>router>msdp

config>router>msdp>group

## Description

This command configures an MSDP peer or MSDP group peer. MSDP must have at least one peer configured. A peer is defined by configuring a **local-address** that is used by the local node to set up a peering session and by configuring the address of a remote MSDP router. It is the address of this remote peer that is configured with this command.

After peer relationships are established, the MSDP peers exchange messages to advertise active multicast sources. If multiple peering sessions are required, multiple peer statements should be included in the configuration.

By default, the parameters applied to a peer are inherited from the global or group level. To override these inherited settings, the parameters must be configured at the peer level.

If the specified peer address is already a configured peer, this command enables the context to configure or modify the peer-specific parameters.

If the specified peer address is not already a configured peer, this command creates the peer instance and enables the context to configure the peer-specific parameters

The peer address is validated and, if valid, will be used as the remote address for an MSDP peering session.

When the **no** form of this command is entered, the existing peering address is removed from the configuration and the existing session is terminated. Whenever a session is terminated, all SA information pertaining to and learned from that peer is removed. Whenever a new peering session is created or a peering session is lost, an event message is generated.

### Default

n/a

### Parameters

*peer-address*

specifies the peer address that identifies the remote MSDP router with which the peering session will be established

## authentication-key

### Syntax

**authentication-key** [*authentication-key* | *hash-key*] [**hash** | **hash2**]

**no authentication-key**

### Context

config>router>msdp>group>peer

config>router>msdp>peer

### Description

This command configures a Message Digest 5 (MD5) authentication key to be used with a specific MSDP peering session. The authentication key must be configured per peer; therefore, no global or group configuration is possible.

Using the **no** form of the command accepts all MSDP messages and disables the MD5 signature option authentication key.

### Default

no authentication-key

### Parameters

*authentication-key*

specifies the authentication key. Allowed values are any string up to 256 characters long composed of printable, 7-bit ASCII characters. If the string contains special characters (such as #, \$, or spaces), the entire string must be enclosed in quotation marks (" ").

*hash-key*

specifies the hash key. The key can be any combination of ASCII characters up to 451 characters in length (encrypted). If spaces are used in the string, the entire string must be enclosed in quotation marks (" ").

This parameter is useful when a user must configure the parameter, but for security purposes, the actual unencrypted key value is not provided.

**hash**

specifies that the key is entered in an encrypted form. If the **hash** or **hash2** parameter is not used, the key is assumed to be in an unencrypted, clear text form. For security, all keys are stored in encrypted form in the configuration file with the **hash** or **hash2** parameter specified.

**hash2**

specifies that the key is entered in a more complex encrypted form that involves more variables than the key value alone, meaning that the **hash2** encrypted variable cannot be copied and pasted. If the **hash** or **hash2** parameter is not used, the key is assumed to be in an unencrypted, clear text form. For security, all keys are stored in encrypted form in the configuration file with the **hash** or **hash2** parameter specified.

## default-peer

**Syntax**

```
[no] default-peer
```

**Context**

```
config>router>msdp>peer
```

```
config>router>msdp>group>peer
```

**Description**

This command enables the default peer mechanism, where a peer can be selected as the default MSDP peer. As a result, all SA messages from the peer will be accepted without the usual peer reverse path forwarding (RPF) check.

The MSDP peer-RPF check is different from the normal multicast RPF checks. The peer-RPF check is used to stop SA messages from looping. A router validates SA messages originated from other routers in a deterministic fashion.

A set of rules is applied to validate received SA messages, and the first rule that applies determines the peer-RPF neighbor. All SA messages from other routers are rejected. The following rules are applied to SA messages originating at router\_S and received at router\_R from router\_N.

- If router\_N and router\_S are the same, the message is originated by a direct peer-RPF neighbor and is accepted.
- If router\_N is a configured peer or a member of the router\_R mesh group, its SA messages are accepted.
- If router\_N is the BGP next hop of the active multicast RPF route toward router\_S, then router\_N is the peer-RPF neighbor and its SA messages are accepted.
- If router\_N is an external BGP peer of router\_R and the last autonomous system (AS) number in the BGP AS-path to router\_S is the same as router\_N's AS number, then router\_N is the peer-RPF neighbor and its SA messages are accepted.
- If router\_N uses the same next hop as the next hop to router\_S, then router\_N is the peer-RPF neighbor and its SA messages are accepted.



- If router\_N fits none of the above rules, then router\_N is not a peer-RPF neighbor and its SA messages are rejected.

When the **no** form the command is issued, no default peer is established and all SA messages are RPF checked.

## Default

no default-peer

## receive-msdp-msg-rate

## Syntax

**receive-msdp-msg-rate** *number interval seconds* [**threshold** *number*]

**no receive-msdp-msg-rate**

## Context

config>router>msdp

config>router>msdp>group

config>router>msdp>group>peer

config>router>msdp>peer

## Description

This command limits the number of MSDP messages that are read from the TCP session to prevent an MSDP RP router from receiving a large number of MSDP message packets in an SA message.

After the number of MSDP packets (including SA messages) defined by the **threshold** *number* have been processed, all other MSDP packets are rate-limited. Messages from the TCP session are no longer accepted until the configured **interval** *seconds* has elapsed. Setting the threshold is useful during at system startup and initialization. No limit is placed on the number of MSDP and SA messages that will be accepted

The **no** form of this command resets the message limit to its default operation.

## Default

n/a

## Parameters

**receive-msdp-msg-rate** *number*

specifies the number of MSDP messages (including SA messages) that are read from the TCP session per **interval** *seconds*

**Values** 10 to 10000

**Default** 0

*seconds*

specifies the interval of time in which the number of MSDP messages set by the **receive-msdp-msg-rate** *number* parameter are read from the TCP session

**Values** 1 to 600

**Default** 0

**threshold** *number*

specifies the number of MSDP messages that can be processed before the MSDP message rate-limiting function is activated

**Values** 1 to 1000000

**Default** 0

## rpf-table

### Syntax

**rpf-table** {*rtable-m* | *rtable-u* | *both*}

**no rpf-table**

### Context

config>router>msdp

### Description

This command configures the sequence of route tables used to find an RPF interface for a particular multicast route.

By default, only the unicast route table is looked up to calculate an RPF interface toward the source/rendezvous point. However, the operator can specify one of the following options:

- use the unicast route table only
- use the multicast route table only
- use both route tables

### Default

*rtable-u*

### Parameters

**rtable-m**

specifies that only the multicast route table is used by the multicast protocol (PIM) for IPv4 RPF checks. This route table contains routes submitted by static routes, ISIS, and OSPF.

**rtable-u**

specifies that only the unicast route table is used by the multicast protocol (PIM) for IPv4 RPF checks. This route table contains routes submitted by all unicast routing protocols.

**both**

specifies that the first lookup is always in the multicast route table, and if there is a route, it will use it. If PIM does not find a route in the first lookup, it tries to find it in the unicast route table.

**sa-timeout****Syntax**

**sa-timeout** *seconds*

**no sa-timeout**

**Context**

config>router>msdp

**Description**

This command configures the timeout value for the SA entries in the cache. If these entries are not refreshed within the timeout value, they are removed from the cache. Normally, the entries are refreshed at least once a minute. However, under high load with many MSDP peers, the refresh cycle could be incomplete. A higher timeout value (more than 90 seconds) could be useful to prevent instabilities in the MSDP cache.

**Default**

90

**Parameters**

*seconds*

specifies the time, in seconds, to wait for a response from the peer before declaring the peer unavailable

**Values** 90 to 600

**SOURCE****Syntax**

**[no] source** *ip-prefix/mask*

**Context**

config>router>msdp

**Description**

This command configures an MSDP source.

If the specified prefix and mask is already configured, this command enables the context to configure or modify the source-specific parameters.

If the specified prefix and mask is not already configured, this command creates the source node instance and enables the context to configure the source-specific parameters.

The SA messages are not rate-limited based on the source address range.

The **no** form of this command removes the sources in the address range.

### Default

n/a

### Parameters

*ip-prefix*

specifies the IP prefix, in dotted-decimal notation, for the MSDP source

**Values** a.b.c.d (host bits must be 0)

*mask*

specifies the subnet mask for the range, expressed as a decimal integer mask length or in dotted-decimal notation

**Values** 0 to 32 (mask length)  
0.0.0.0 to 255.255.255.255 (dotted-decimal)

## 3.19.2.2 Show commands



**Note:** The following command outputs are examples only; actual displays may differ depending on supported functionality and user configuration.

```
igmp
```

### Syntax

```
igmp
```

### Context

```
show>router
```

### Description

This command enables the context to display IGMP information.

```
group
```

### Syntax

```
group [grp-ip-address]
```

```
group summary
```

## Context

```
show>router>igmp
```

## Description

This command displays the multicast group and (S,G) addresses. If no *grp-ip-address* parameters are specified, then all IGMP group, (\*,G) and (S,G) addresses are displayed.

## Parameters

*grp-ip-address*

displays specific multicast group addresses

## Output

The following output is an example of IGMP group information, and [Table 6: IGMP group field descriptions](#) describes the fields.

### Output example

```
*B:Dut-C# show router igmp group
=====
IGMP Interface Groups
=====
IGMP Host Groups
=====
(*,239.255.0.1)
  Fwd List : 239.255.1.2          Up Time : 0d 00:00:21
(10.11.0.1,239.255.0.1)
  Fwd List : 239.255.1.1          Up Time : 0d 00:00:30
  Blk List : 239.255.1.20        Up Time : 0d 00:00:21
(10.11.0.2,239.255.0.100)
  Fwd List : 239.255.1.30        Up Time : 0d 00:00:30
(*,239.255.0.200)
  Fwd List : 239.255.1.40        Up Time : 0d 00:00:21
(10.11.0.3,239.255.0.210)
  Blk List : 239.255.1.50        Up Time : 0d 00:00:21
-----
(*,G)/(S,G) Entries : 5
=====
*B:Dut-C#
```

```
*B:Dut-C# show router igmp group summary
=====
IGMP Interface Groups
=====
IGMP Host Groups Summary
=====
(*,239.255.0.1)          1          0
(10.11.0.1,239.255.0.1) 1          1
(10.11.0.2,239.255.0.100) 1          0
(*,239.255.0.2)         1          0
(10.11.0.3,239.0.0.200) 0          1
-----
(*,G)/(S,G) Entries : 5
=====
```

```
*B:Dut - C#
```

Table 6: IGMP group field descriptions

Label	Description
IGMP Host Groups Summary	The IP multicast sources corresponding to the IP multicast groups that are statically configured
Nbr Fwd Hosts	The number of forwarding hosts
Nbr Blk Hosts	The number of blocking hosts

## interface

### Syntax

```
interface [ip-int-name | ip-address] [group] [grp-ip-address] [detail]
```

### Context

```
show>router>igmp
```

### Description

This command displays IGMP interface information.

### Parameters

*ip-int-name*

displays only the information associated with the specified IP interface name

*ip-address*

displays only the information associated with the specified IP address

*grp-ip-address*

displays only the IP multicast group address for which this entry contains information

**detail**

displays detailed IP interface information along with the source group information learned on that interface

### Output

The following output is an example of IGMP interface information, and [Table 7: IGMP interface field descriptions](#) describes the fields.

### Output example

```
*A:ALU-BA# show router 100 interface
=====
Interface Table (Service: 100)
=====
Interface-Name      Adm      Opr (v4/v6)      Mode      Port/SapId
```

```

IP-Address                                     PfxState
-----
IGMP_to_CE                                   Up          Up          VPRN      1/1/7
 10.1.1.1/24 n/a
system                                       Up          Up          VPRN      loopback
 10.20.1.2/32 n/a
-----
Interfaces : 2
=====
*A:ALU-BA#
    
```

```

*A:ALU-BA# show router 100 interface IGMP_to_CE
=====
Interface Table (Service: 100)
=====
Interface-Name      Adm          Opr(v4/v6)    Mode        Port/SapId
IP-Address          PfxState
-----
IGMP_to_CE          Up           Up            VPRN        1/1/7
 10.1.1.1/24        n/a
-----
Interfaces : 1
=====
*A:ALU-BA#
    
```

```

*A:ALU-BA# show router 100 igmp interface
=====
IGMP Interfaces
=====
Interface          Adm          Oper          Querier      Cfg/Opr      Num          Policy
                  Version      Groups
-----
IGMP_to_CE         Up           Up            10.1.1.1    1/1          3            igmppol
-----
Interfaces : 1
=====
*A:ALU-BA#
    
```

```

*A:ALU-BA# show router 100 igmp interface IGMP_to_CE
=====
IGMP Interface IGMP_to_CE
=====
Interface          Adm          Oper          Querier      Cfg/Opr      Num          Policy
                  Version      Groups
-----
IGMP_to_CE         Up           Up            10.1.1.1    1/1          3            igmppol
-----
Interfaces : 1
=====
*A:ALU-BA#
    
```

```

*A:ALU-BA# show router 100 igmp interface 10.1.1.1
=====
IGMP Interface 10.1.1.1
=====
Interface          Adm          Oper          Querier      Cfg/Opr      Num          Policy
                  Version      Groups
-----
IGMP_to_CE         Up           Up            10.1.1.1    1/1          3            igmppol
-----
Interfaces : 1
    
```

```

=====
*A:ALU-BA#

*A:ALU-BA# show router 100 igmp interface IGMP_to_CE group 239.255.1.1
=====
IGMP Interface IGMP_to_CE
=====
Interface      Adm      Oper      Querier      Cfg/Opr      Num      Policy
                  Version    Groups
-----
IGMP_to_CE    Up       Up        10.1.1.1    1/1          3        igmppol
=====
IGMP Group
-----
Group Address : 239.255.1.1      Up Time      : 0d 00:03:52
Interface     : IGMP_to_CE      Expires      : never
Last Reporter : 0.0.0.0          Mode         : exclude
V1 Host Timer : Not running      Type         : static
V2 Host Timer : Not running      Compat Mode  : IGMP Version 3
-----
Interfaces : 1
=====
*A:ALU-BA#
    
```

```

=====
*A:ALU-BA# show router 100 igmp interface IGMP_to_CE group 239.255.1.1 detail
=====
IGMP Interface IGMP_to_CE
=====
Interface      : IGMP_to_CE
Admin Status   : Up           Oper Status   : Up
Querier        : 10.1.1.1   Querier Up Time : 0d 00:04:01
Querier Expiry Time : N/A         Time for next query : 0d 00:13:42
Admin/Oper version : 1/1        Num Groups    : 3
Policy         : igmppol   Subnet Check   : Disabled
Max Groups Allowed : 16000      Max Groups Till Now : 3
MCAC Policy Name : MCAC        Const Adm St   : Enable
MCAC Max Unconst BW : no limit   MCAC Max Mand BW : no limit
MCAC In use Mand BW : 0         MCAC Avail Mand BW : unlimited
MCAC In use Opnl BW : 0         MCAC Avail Opnl BW : unlimited
-----
IGMP Group
-----
Group Address   : 239.255.1.1      Up Time       : 0d 00:04:02
Interface       : IGMP_to_CE      Expires       : never
Last Reporter   : 0.0.0.0          Mode          : exclude
V1 Host Timer   : Not running      Type          : static
V2 Host Timer   : Not running      Compat Mode   : IGMP Version 3
-----
    
```

Table 7: IGMP interface field descriptions

Label	Description
Interface	The interface that participates in the IGMP protocol
Adm Admin Status	The administrative state for the IGMP protocol on this interface



Label	Description
Querier	The address of the IGMP querier on the IP subnet to which the interface is attached
Oper Oper Status	The current operational state of the IGMP protocol on the interface
Querier Up Time	The time since the querier was last elected as querier
Querier Expiry Time	The time remaining before the querier ages out. If the querier is the local interface address, the value will be zero.
Cfg/Opr Version Admin/Oper version	Cfg – the configured version of IGMP running on this interface. For IGMP to function correctly, all routers on a LAN must be configured to run the same version of IGMP on that LAN.  Opr – the operational version of IGMP running on this interface. If the cfg value is 3 but all of the routers in the local subnet of this interface use IGMPv1 or IGMPv2, the operational version will be v1 or v2 (as appropriate).
Num Groups	The number of multicast groups that have been learned by the router on the interface
Policy	The policy that is to be applied on the interface
Group Address	The IP multicast group address for which this entry contains information
Up Time	The time since this source group entry got created
Last Reporter	The IP address of the source of the last membership report received for this IP multicast group address on this interface. If no membership report has been received, this object has the value 0.0.0.0.
Mode	The mode is based on the type of membership reports received on the interface for the group  Include – reception of packets sent to the specified multicast address is requested only from those IP source addresses listed in the source-list parameter of the IGMP membership report  Exclude – reception of packets sent to the given multicast address is requested from all IP source addresses except those listed in the source-list parameter
V1 Host Timer	The time remaining until the local router assumes that there are no longer any IGMPv1 members on the IP subnet attached to this interface. Upon hearing any IGMPv1 membership report, this value is reset to the group membership timer. While this time remaining is non-zero, the local router ignores any IGMPv2 Leave messages for this group that it receives on this interface.

Label	Description
V2 Host Timer	The time remaining until the local router assumes that there are no longer any IGMPv2 members on the IP subnet attached to this interface. Upon hearing any IGMPv2 membership report, this value is reset to the group membership timer. While this time remaining is non-zero, the local router ignores any IGMPv3 Leave messages for this group that it receives on this interface.
Type	Indicates how this group entry was learned. If this group entry was learned by IGMP, it will be set to "dynamic". For statically configured groups, the value will be set to "static".
Compat Mode	Used in order for routers to be compatible with older version routers. IGMPv3 hosts must operate in version 1 and version 2 compatibility modes. IGMPv3 hosts must keep track of the state per local interface regarding the compatibility mode of each attached network.  A host's compatibility mode is determined from the Host Compatibility Mode variable, which can be in one of three states: IGMPv1, IGMPv2 or IGMPv3. This variable is kept per interface and is dependent on the version of General Queries heard on that interface as well as the Older Version Querier Present timers for the interface.

## ssm-translate

### Syntax

**ssm-translate** [*interface-name*]

### Context

show>router>igmp

### Description

This command displays IGMP SSM translate configuration information.

### Parameters

*interface-name*

displays the information associated with the specified IP interface name (the interface name can have up to 32 characters and must start with a letter)

### Output

The following output is an example of IGMP ssm-translate configuration information, and [Table 8: IGMP SSM-translate field descriptions](#) describes the fields.

**Output example**

```
*A:7705custDoc:Sar18>show>router>igmp# ssm-translate
=====
IGMP SSM Translate Entries
=====
Group Range                Source                Interface
-----
<239.255.10.0 - 239.255.10.10>  10.10.10.10         igmp_interface
-----
SSM Translate Entries : 1
=====
*A:7705custDoc:Sar18>show>router>igmp#
```

Table 8: IGMP SSM-translate field descriptions

Label	Description
Group Range	The address ranges of the multicast groups to which this router can belong
Source	The unicast address that sends data on an interface
Interface	The name of the interface
SSM Translate Entries	The total number of SSM translate entries

**static****Syntax**

**static** [*ip-int-name* | *ip-address*]

**Context**

show>router>igmp

**Description**

This command displays static IGMP, (\*,G), and (S,G) information.

**Parameters**

*ip-int-name*

displays the information associated with the specified IP interface name

*ip-address*

displays the information associated with the specified IP address in the format a.b.c.d

**Output**

The following output is an example of static IGMP information, and [Table 9: Static IGMP field descriptions](#) describes the fields.

## Output example

```
*A:7705custDoc:Sar18>show>router>igmp# static
=====
IGMP Static Group Source
=====
Source          Group          Interface
-----
10.11.11.11     239.255.22.3  IGMP_to_CE
-----
Static (*,G)/(S,G) Entries : 1
=====
```

Table 9: Static IGMP field descriptions

Label	Description
Source	The entries that represent a source address from which receivers are interested or not interested in receiving multicast traffic
Group	The IP multicast group address for which this entry contains information
Interface	The interface name

## statistics

### Syntax

**statistics** [*ip-int-name* | *ip-address*]

### Context

show>router>igmp

### Description

This command displays IGMP statistics information.

### Parameters

*ip-int-name*

displays the information associated with the specified IP interface name

*ip-address*

displays the information associated with the specified IP address

### Output

The following output is an example of IGMP statistic information, and [Table 10: IGMP statistics field descriptions](#) describes the fields.

**Output example**

```
*A:ALU-BA# show router igmp statistics
=====
IGMP Interface Statistics
=====
Message Type      Received      Transmitted
-----
Queries           0             5
Report V1         0             0
Report V2         0             0
Report V3         10            0
Leaves            0             0
-----
General Interface Statistics
-----
Bad Length       : 0
Bad Checksum     : 0
Unknown Type    : 0
Bad Receive If  : 0
Rx Non Local     : 0
Rx Wrong Version : 0
Policy Drops    : 0
No Router Alert : 0
Rx Bad Encodings : 0
Local Scope Pkts : 0
Resvd Scope Pkts : 0
-----
Source Group Statistics
-----
(S,G)           : 2
(*,G)           : 1
=====
*A:ALU-BA#
```

Table 10: IGMP statistics field descriptions

Label	Description
<b>IGMP Interface Statistics</b>	
Message Type	Queries – The number of IGMP general queries transmitted or received on this interface
	Report – The total number of IGMPv1, IGMPv2, or IGMPv3 reports transmitted or received on this interface
	Leaves – The total number of IGMP leaves transmitted on this interface
Received	The total number of IGMP packets received on this interface
Transmitted	The total number of IGMP packets transmitted from this interface
<b>General Interface Statistics</b>	
Bad Length	The total number of IGMP packets with bad length received on this interface

Label	Description
Bad Checksum	The total number of IGMP packets with bad checksum received on this interface
Unknown Type	The total number of IGMP packets with unknown type received on this interface
Bad Receive If	The total number of IGMP packets incorrectly received on this interface
Rx Non Local	The total number of IGMP packets received from a non-local sender
Rx Wrong Version	The total number of IGMP packets with wrong versions received on this interface
Policy Drops	The total number of times that the IGMP protocol instance matched the host IP address or group/source addresses specified in the import policy
No Router Alert	The total number of IGMPv3 packets received on this interface that did not have the router alert flag set
Rx Bad Encodings	The total number of IGMP packets with bad encoding received on this interface
Local Scope Pkts	The total number of IGMP packets received with scope field of node-local on this interface
Resvd Scope Pkts	The total number of IGMP packets with reserved scope on this interface
<b>Source Group Statistics</b>	
(S,G)	The total number of (S,G)s for IGMP
(* ,G)	The total number of (* ,G)s for IGMP

## status

### Syntax

**status**

### Context

show>router>igmp

## Description

This command displays IGMP status information. If IGMP is not enabled, the following message appears:

```
A:NYC# show router igmp status
MINOR: CLI IGMP is not configured.
A:NYC#
```

## Output

The following output is an example of IGMP status information, and [Table 11: IGMP status field descriptions](#) describes the fields.

### Output example

```
*A:ALU-BA# show router 100 igmp status
=====
IGMP Status
=====
Admin State                : Up
Oper State                 : Up
Query Interval             : 1024
Last Member Query Interval : 1024
Query Response Interval    : 1023
Robust Count               : 10
=====
*A:ALU-BA#
```

Table 11: IGMP status field descriptions

Label	Description
Admin State	The administrative status of IGMP
Oper State	The current operating state of this IGMP protocol instance on this router
Query Interval	The frequency at which IGMP query packets are transmitted
Last Member Query Interval	The maximum response time inserted into group-specific queries sent in response to leave group messages Also, the amount of time between group-specific query messages
Query Response Interval	The maximum query response time advertised in IGMPv2 queries
Robust Count	The number of times the router will retry a query

mld

## Syntax

mld

**Context**

```
show>router
```

**Description**

This command enables the context to display MLD information.

```
group
```

**Syntax**

```
group [grp-ipv6-address]
```

**Context**

```
show>router>mld
```

**Description**

This command displays MLD group information.

**Parameters**

*grp-ipv6-address*  
the IPv6 group address

**Output**

The following output is an example of MLD group information, and [Table 12: MLD group field descriptions](#) describes the fields.

**Output example**

```
*A:ALU# show router mld group
=====
MLD Groups
=====
(3FFE:100::2:100,FF05::1:1)
  Up Time      : 0d 00:00:31
  Fwd List     : Host1

(3FFE:100::2:100,FF05::1:2)
  Up Time      : 0d 00:00:31
  Fwd List     : Host1

(3FFE:100::2:100,FF05::1:3)
  Up Time      : 0d 00:00:31
  Fwd List     : Host1

(3FFE:100::2:100,FF05::1:4)
  Up Time      : 0d 00:00:31
  Fwd List     : Host1

(3FFE:100::2:100,FF05::1:5)
=====
```



```

*A:ALU#

*A:ALU# show router mld group ff05::1:1
=====
MLD Groups
=====
(3FFE:100::2:100,FF05::1:1)
  Up Time      : 0d 00:00:40
  Fwd List     : Host1
-----
(*,G)/(S,G) Entries : 1
=====
*A:ALU#

```

Table 12: MLD group field descriptions

Label	Description
Up Time	The length of time that the interface has been part of the MLD group
Fwd List	The forwarding list associated with the MLD group

## interface

### Syntax

**interface** [*ip-int-name* | *ip-address*] [**group**] [*grp-ipv6-address*] [**detail**]

### Context

show>router>mld

### Description

This command displays MLD interface information.

### Parameters

*ip-int-name*

the IP interface name

*ip-address*

the IPv6 interface address (x:x:x:x:x:x)

*grp-ipv6-address*

the IPv6 multicast group address

**detail**

displays detailed information

## Output

The following output is an example of MLD interface information, and [Table 13: MLD interface field descriptions](#) describes the fields.

### Output example

```
*A:7705custDoc:Sar18>show>router>mld# interface mld_interface
=====
MLD Interface mld_interface
=====
Interface          Adm  Oper  Cfg/Opr      Num      Policy
  Querier          Version  Groups
-----
mld_interface      Up    Down  2/2          0         none
::
-----
Interfaces : 1
=====
*A:7705custDoc:Sar18>config>router>mld>if#
```

```
*A:7705custDoc:Sar18>show>router>mld# interface mld_interface detail
=====
MLD Interface mld_interface
=====
Interface          : mld_interface
Admin Status       : Up
Oper Status        : Down
Querier            : ::
Querier Up Time    : 0d 00:00:00
Querier Expiry Time : N/A
Admin/Oper version : 2/2
Num Groups         : 0
Policy             : none
Max Groups Allowed : No Limit
Max Groups Till Now: 0
Query Interval     : 0
Query Resp Interval: 0
Last List Qry Interval : 0
Router Alert Check : Enabled
-----
Interfaces : 1
=====
```

```
*A:ALU# show router mld interface
=====
MLD Interfaces
=====
Interface          Adm  Oper  Cfg/Opr      Num      Policy
  Querier          Version  Groups
-----
Host4_Srce1_IPv6   Up    Up    2/2          0         none
FE80::216:4DFF:FED4:4D5B
Host1               Up    Up    2/2          0         none
FE80::216:4DFF:FED4:4D5B
Host2               Up    Up    2/2          0         none
FE80::216:4DFF:FE51:3728
Host3_vlan1         Up    Up    2/2          0         none
FE80::216:4DFF:FE51:3729
Host3_vlan2         Up    Up    2/2          0         none
FE80::216:4DFF:FE51:3729
Host3_vlan3         Up    Up    2/2          0         none
FE80::216:4DFF:FE51:3729
Host3_vlan4         Up    Up    2/2          0         none
FE80::216:4DFF:FE51:3729
Host3_vlan5         Up    Up    2/2          0         none
```

\*A:ALU

\*A:ALU# show router mld interface Host1 detail

=====

MLD Interface Host1

=====

```

Interface           : Host1
Admin Status        : Up                Oper Status         : Up
Querier             : FE80::216:4DFF:FED4:4D5B
Querier Up Time     : 0d 00:02:18
Querier Expiry Time : N/A                Time for next query: 0d 00:15:25
Admin/Oper version  : 2/2                Num Groups          : 6000
Policy              : none
Max Groups Allowed  : No Limit           Max Groups Till Now: 6000
Query Interval      : 0                Query Resp Interval: 0
Last List Qry Interval : 0           Router Alert Check : Enabled
    
```

-----

MLD Group

-----

```

Group Address       : FF05::1:1
Last Reporter       : FE80::1
Interface           : Host1             Expires : N/A
Up Time             : 0d 00:00:10       Mode    : include
V1 Host Timer       : Not running        Type    : dynamic
Compat Mode         : MLD Version 2
    
```

-----

Source

Expires	Type	Fwd/Blk
3FFE:100::2:100 0d 00:34:07	dynamic	Fwd

-----

-----

MLD Group

-----

```

Group Address       : FF05::1:2
Last Reporter       : FE80::1
Interface           : Host1             Expires           : N/A
Up Time             : 0d 00:00:11       Mode              : include
V1 Host Timer       : Not running        Type              : dynamic
Compat Mode         : MLD Version 2
    
```

-----

Source

Expires	Type	Fwd/Blk
3FFE:100::2:100 0d 00:34:07	dynamic	Fwd

-----

-----

MLD Group

-----

```

Group Address       : FF05::1:3
Last Reporter       : FE80::1
Interface           : Host1             Expires           : N/A
Up Time             : 0d 00:00:11       Mode              : include
V1 Host Timer       : Not running        Type              : dynamic
Compat Mode         : MLD Version 2
    
```

-----

Source

Expires	Type	Fwd/Blk
3FFE:100::2:100 0d 00:34:07	dynamic	Fwd

-----

-----

MLD Group

-----

```

-----
Group Address      : FF05::1:4
Last Reporter     : FE80::1
Interface         : Host1           Expires      : N/A
Up Time          : 0d 00:00:12      Mode         : include
V1 Host Timer    : Not running      Type         : dynamic
Compat Mode      : MLD Version 2
-----
Source
Expires          Type          Fwd/Blk
-----
3FFE:100::2:100
0d 00:34:06      dynamic      Fwd
-----
MLD Group
-----
Group Address      : FF05::1:5
Last Reporter     : FE80::1
Interface         : Host1           Expires      : N/A
Up Time          : 0d 00:00:12      Mode         : include
V1 Host Timer    : Not running      Type         : dynamic
Compat Mode      : MLD Version 2
-----
Source
Expires          Type          Fwd/Blk
-----
3FFE:100::2:100
0d 00:34:06      dynamic      Fwd
-----
*A:ALU# show router mld interface Host1 detail

```

Table 13: MLD interface field descriptions

Label	Description
<b>MLD Interface</b>	
Interface	The interface that participates in the MLD protocol
Admin Status	The administrative state for the MLD protocol on this interface
Oper Status	The current operational state of the MLD protocol on the interface
Querier	The address of the MLD querier on the IP subnet to which the interface is attached
Querier Up Time	The time since the querier was last elected as querier
Querier Expiry Time	The time remaining before the querier ages out. If the querier is the local interface address, the value will be zero.
Time for next query	The time until the next query is sent
Admin/Oper version	The operational version of MLD running on this interface. If the cfg value is 2 but all of the routers in the local subnet of this interface use MLDv1, the operational version will be v1.

Label	Description
Num Groups	The number of multicast groups that have been learned by the router on the interface
Policy	The policy that is to be applied on the interface
Max Groups Allowed	The maximum number of groups allowed for this interface
Max Groups Till Now	The maximum number of groups joined for this interface up until the present time
Query Interval	The frequency at which MLD query packets are transmitted
Query Resp Interval	The length of time that the interface will wait for a query response
Last List Qry Interval	The maximum response time inserted into group-specific queries sent in response to leave group messages Also, the amount of time between group-specific query messages
Router Alert Check	The status of the MLD message router alert check: enabled or disabled. When enabled (default), messages without the hop-by-hop router alert extension header in the IPv6 header will be rejected.
<b>MLD Group</b>	
Group Address	The IPv6 multicast group address for which this entry contains information
Last Reporter	The IPv6 address of the source of the last membership report received for this IP multicast group address on this interface. If no membership report has been received, this object has the value 0.0.0.0.
Interface	The interface that participates in the MLD protocol
Expires	The length of time until the interface leaves the MLD group
Up Time	The time since this source group entry got created
Mode	The mode is based on the type of membership reports received on the interface for the group.  Include – reception of packets sent to the specified multicast address is requested only from those IP source addresses listed in the source-list parameter of the IGMP membership report  Exclude – reception of packets sent to the given multicast address is requested from all IP source addresses except those listed in the source-list parameter
V1 Host Timer	The time remaining until the local router assumes that there are no longer any MLDv1 members on the IP subnet attached to this interface. Upon hearing any MLDv1 membership report, this

Label	Description
	value is reset to the group membership timer. While this time remaining is non-zero, the local router ignores any MLDv2 Leave messages for this group that it receives on this interface.
Type	Indicates how this group entry was learned. If this group entry was learned by MLD, it will be set to "dynamic". For statically configured groups, the value will be set to "static".
Compat Mode	Used in order for routers to be compatible with older version routers. MLDv2 hosts must operate in version 1 compatibility mode. MLDv2 hosts must keep track of the state per local interface regarding the compatibility mode of each attached network.  A host's compatibility mode is determined from the Host Compatibility Mode variable, which can be in one of two states: MLDv1 or MLDv2. This variable is kept per interface and is dependent on the version of General Queries heard on that interface as well as the Older Version Querier Present timers for the interface.
<b>Source</b>	
Expires	The length of time until the source leaves the MLD group
Type	The type of message that was used to join the source: dynamic or static
Fwd/Blk	The state of the source: forwarding or blocking

## ssm-translate

### Syntax

**ssm-translate** [*interface-name*]

### Context

show>router>mld

### Description

This command displays the MLD SSM translate configuration.

### Parameters

*interface-name*

displays the information associated with the specified IP interface name (the interface name can have up to 32 characters and must start with a letter)

## Output

The following output is an example of MLD ssm-translate information, and [Table 14: MLD SSM-translate field descriptions](#) describes the fields.

### Output example

```
*A:7705custDoc:Sar18>show>router>mld# ssm-translate mld_interface
=====
MLD SSM Translate Entries
=====
Group Range                Source                Interface
-----
<239.255.10.0 - 239.255.10.10>  10.10.10.10         mld_interface
-----
SSM Translate Entries : 1
=====
*A:7705custDoc:Sar18>show>router>mld#
```

Table 14: MLD SSM-translate field descriptions

Label	Description
Group Range	The address range of the multicast group for this interface
Source	The unicast address that sends data on an interface
Interface	The name of the interface
SSM Translate Entries	The total number of SSM translate entries

## static

### Syntax

**static** [*ip-int-name* | *ip-address*]

### Context

show>router>mld

### Description

This command displays MLD static group and source configuration.

### Parameters

*ip-int-name*

the IP interface name

*ip-address*

the IPv6 interface address in the format x:x:x:x:x:x

## Output

The following output is an example of MLD static group and source configuration information, and [Table 15: MLD static group field descriptions](#) describes the fields.

### Output example

```
*A:7705custDoc:Sar18# show router mld static
=====
MLD Static Group Source
=====
Source                               Group
  Interface
-----
No Matching Entries
=====
*A:7705custDoc:Sar18#
```

Table 15: MLD static group field descriptions

Label	Description
Source	The entries that represent a source address from which receivers are interested or not interested in receiving multicast traffic
Group	The IP multicast group address for which this entry contains information
Interface	The IPv6 interface name

## statistics

### Syntax

**statistics** [*ip-int-name* | *ipv6-address*]

### Context

show>router>mld

### Description

This command displays MLD statistics.

### Parameters

*ip-int-name*

displays the information associated with the specified IP interface name

*ipv6-address*

displays the information associated with the specified IPv6 address in the format X:X:X:X:X:X:X



## Output

The following output is an example of MLD statistics information, and [Table 16: MLD statistics field descriptions](#) describes the fields.

### Output example

```
*A:7705custDoc:Sar18>show>router>mld# statistics
=====
MLD Interface Statistics
=====
Message Type          Received      Transmitted
-----
Queries               0             0
Report V1             0             0
Report V2             0             0
Dones                 0             0
-----
General Interface Statistics
-----
Bad Length           : 0
Bad Checksum         : 0
Unknown Type        : 0
Bad Receive If      : 0
Rx Non Local        : 0
Rx Wrong Version    : 0
Policy Drops        : 0
No Router Alert     : 0
Rx Bad Encodings    : 0
Rx Pkt Drops        : 0
Local Scope Pkts    : 0
Resvd Scope Pkts    : 0
-----
Source Group Statistics
-----
(S,G)                : 0
(*,G)                : 0
=====
*A:7705custDoc:Sar18>show>router>mld#
```

Table 16: MLD statistics field descriptions

Label	Description
<b>MLD Interface Statistics</b>	
Message Type	Queries – the number of MLD general queries transmitted or received on this interface
	Reports – the total number of MLDv1 or MLDv2 reports transmitted or received on this interface
	Dones – the total number of MLD dones transmitted on this interface
Received	The total number of MLD packets received on this interface
Transmitted	The total number of MLD packets transmitted from this interface

Label	Description
<b>General Interface Statistics</b>	
Bad Length	The total number of MLD packets with bad length received on this interface
Bad Checksum	The total number of MLD packets with bad checksum received on this interface
Unknown Type	The total number of MLD packets with unknown type received on this interface
Bad Receive If	The total number of MLD packets incorrectly received on this interface
Rx Non Local	The total number of MLD packets received from a non-local sender
Rx Wrong Version	The total number of MLD packets with wrong versions received on this interface
Policy Drops	The total number of times that the MLD protocol instance matched the host IP address or group/source addresses specified in the import policy
No Router Alert	The total number of MLDv2 packets received on this interface that did not have the router alert flag set
Rx Bad Encodings	The total number of MLD packets with bad encoding received on this interface
Rx Pkt Drops	The number of receive packets dropped by this interface
Local Scope Pkts	The total number of MLD packets received with scope field of node-local on this interface
Resvd Scope Pkts	The total number of MLD packets with reserved scope on this interface
<b>Source Group Statistics</b>	
(S,G)	The total number of (S,G)s for MLD
(* ,G)	The total number of (* ,G)s for MLD

status

**Syntax**  
status

## Context

show>router>mld

## Description

This command displays the MLD status.

## Output

The following output is an example of MLD status information, and [Table 17: MLD status field descriptions](#) describes the fields.

### Output example

```
*A:7705Sar18>show>router>mld# status
=====
MLD Status
=====
Admin State           : Up
Oper State           : Up
Query Interval       : 125
Last Listener Query Interval : 1
Query Response Interval : 10
Robust Count         : 2
=====
*A:7705Sar18>show>router>mld#
```

Table 17: MLD status field descriptions

Label	Description
Admin State	The administrative status of MLD
Oper State	The current operating state of this MLD protocol instance on this router
Query Interval	The frequency at which MLD query packets are transmitted
Last Listener Query Interval	The maximum response time inserted into group-specific queries sent in response to leave group messages Also, the amount of time between group-specific query messages
Query Response Interval	The maximum query response time advertised in MLDv2 queries
Robust Count	The number of times the router will retry a query

## pim

## Syntax

pim

**Context**

```
show>router
```

**Description**

This command enables the context to display PIM information.

```
group
```

**Syntax**

```
group [grp-ip-address] [source ip-address] [detail] [family]
```

**Context**

```
show>router>pim
```

**Description**

This command displays PIM source group database information.

**Parameters**

*grp-ip-address*

the IP multicast group address for which this entry contains information

*ip-address*

the source address for which this entry contains information

**detail**

displays detailed group information

*family*

displays either IPv4 or IPv6 information

**Values** ipv4 or ipv6

**Output**

The following output is an example of PIM group information, and [Table 18: PIM group field descriptions](#) describes the fields.

**Output example**

```
*A:7CSA:Dut-C# show router pim group
=====
PIM Groups ipv4
=====
Group Address          Type   Spt Bit Inc Intf      No.0ifs
Source Address         RP
-----
239.255.0.0           (S,G)                ip-10.1.7.7    16
 10.111.1.2
239.255.0.1           (S,G)                ip-10.1.7.7    16
 10.111.1.2
239.255.0.2           (S,G)                ip-10.1.7.7    16
```

```

10.111.1.2
239.255.0.3          (S,G)          ip-10.1.7.7    16
10.111.1.2
239.255.0.4          (S,G)          ip-10.1.7.7    16
10.111.1.2
-----
Groups : 5
=====

```

```

*A:7CSA:Dut-C# show router pim group 239.255.0.0
=====
PIM Groups ipv4
=====
Group Address          Type      Spt Bit Inc Intf      No.0ifs
  Source Address          RP
-----
239.255.0.0            (S,G)          ip-10.1.7.7    16
10.11.1.2
-----
Groups : 1
=====

```

```

*A:7CSA:Dut-C# show router pim group 239.255.0.0 detail
=====
PIM Source Group ipv4
=====
Group Address      : 239.255.0.0
Source Address     : 10.111.1.2
RP Address         : 0
Flags              :
MRIB Next Hop     : 10.1.7.1
MRIB Src Flags    : remote
Up Time           : 0d 00:27:25
Up JP State       : Joined
Up JP Rpt        : Not Joined StarG
Register State    : No Info
Reg From Anycast RP: No

Rpf Neighbor      : 10.1.7.1
Incoming Intf     : ip-10.1.7.7
Outgoing Intf List : ip-10.112.1.1, ip-10.112.2.1, ip-10.112.3.1
                  : ip-10.112.4.1, ip-10.112.5.1, ip-10.112.6.1
                  : ip-10.112.7.1, ip-10.112.8.1, ip-10.112.9.1
                  : ip-10.112.10.1, ip-10.112.11.1, ip-10.112.12.1
                  : ip-10.112.13.1, ip-10.112.14.1, ip-10.112.15.1
                  : ip-10.112.16.1
Curr Fwding Rate  : 0.0 kbps
Forwarded Packets : 0
Forwarded Octets  : 0
Discarded Packets : 0
RPF Mismatches    : 0
Type              : (S,G)
Keepalive Timer   : Not Running
Resolved By       : rtable-u
Up JP Expiry      : 0d 00:00:35
Up JP Rpt Override : 0d 00:00:00

Groups : 1
=====

```

Table 18: PIM group field descriptions

Label	Description
Group Address	The IP multicast group address for which this entry contains information

Label	Description
Source Address	The source address of the multicast sender
RP Address	Always set to 0 (zero)
Flags	The lists to which this interface belongs
Type	The type of entry: (*, *, rp)/(*,G) or (S,G) The 7705 SAR only supports and will only indicate (S,G)
Spt Bit	Specifies whether to forward on (*, *, rp)/(*,G) or on (S,G) state. It is updated when the (S,G) data comes on the RPF interface toward the source. The 7705 SAR only supports and will only indicate (S,G)
Inc Intf	The incoming interface on which the traffic arrives (that is, the RPF interface to the source)
No. Oifs	The number of interfaces in the inherited outgoing interface list, where an inherited list inherits the state from other types
MRIB Next Hop	The next-hop address toward the source
MRIB Src Flags	The MRIB information for the source
Keepalive Timer	The keepalive timer is applicable only for (S,G) entries The (S,G) keepalive timer is updated by data being forwarded using this (S,G) Forwarding state. It is used to keep the (S,G) state alive in the absence of explicit (S,G) joins.
Up Time	The length of time since this source group entry was created
Resolved By	The route table used for the RPF check
Up JP State	The upstream Join Prune state for this entry on the interface. PIM Join Prune messages are sent by the downstream routers toward the RPF neighbor.
Up JP Expiry	The minimum amount of time remaining before this entry will be aged out
Up JP Rpt	The Join Prune Rpt state for this entry on the interface. PIM Join Prune messages are sent by the downstream routers toward the RPF neighbor. The (S,G, rpt) state is a result of receiving an (S,G, rpt) JP message from the downstream router on the source tree.
Up JP Rpt Override	The value used to delay triggered Join (S,G, rpt) messages to prevent implosions of triggered messages If this has a non-zero value, it means that the router was in a "not Pruned" state and it saw a prune (S,G, rpt) message being sent to the RPF (S,G, rpt). If the router sees a join (S,G, rpt) override

Label	Description
	message being sent by some other router on the LAN while the timer is still non-zero, it simply cancels the override timer. If it does not see a join (S,G, rpt) message, then on expiry of the override timer, it sends its own join (S,G, rpt) message to the RPF (S,G, rpt).
Register State	The register state: always displays "No info"
Register Stop Exp	The time remaining before the register state might transition to a different state
Reg from Anycast RP	The receive status of the Register packet for that group from one of the RPs from the anycast-RP set: always displays "No"
RPF Neighbor	The address of the Reverse Path Forwarding (RPF) neighbor
Outgoing Intf List	A list of interfaces on which data is forwarded
Curr Fwding Rate	The current forwarding rate of the multicast data for this group and source
Forwarded Packets	The number of multicast packets that were forwarded to the interfaces in the outgoing interface list
Discarded Packets	The number of multicast packets that matched this source group entry but were discarded  For (S,G) entries, if the traffic is getting forwarded on the SPT (Shortest Path Tree), the packets arriving from the RPT will be discarded
Forwarded Octets	The number of octets forwarded
RPF Mismatches	The number of multicast packets that matched this source group entry but they did not arrive on the interface
Spt threshold	The value of the SPT threshold configured for that group: 0 kbps means that the switch to the SP tree will happen immediately

## interface

### Syntax

**interface** [*ip-int-name* | *mt-int-name* | *int-ip-address*] [**group** *grp-ip-address*] [**source** *ip-address*] [**detail**] [*family*]

### Context

show>router>pim

### Description

This command displays PIM interface information and the (S,G) state of the interface.

### Parameters

*ip-int-name*

displays the interface information associated with the specified IP interface name

*mt-int-name*

displays information on the multicast tunnel (MT) interface for a VPRN

**Values** *vprn-id-mt-grp-ip-address*

*ip-address*

displays the interface information associated with the specified IP address

*grp-ip-address*

the IP multicast group address for which this entry contains information

**source** *ip-address*

specifies the source address for which this entry contains information

**detail**

displays detailed interface information

*family*

displays IPv4 or IPv6 information for the interface

**Values** *ipv4 or ipv6*

### Output

The following output is an example of PIM interface information, and [Table 19: PIM interface field descriptions](#) describes the fields.

#### Output example

```
*A:7705:Dut-A# show router pim interface
=====
PIM Interfaces ipv4
=====
Interface                Adm  Opr  DR Prty      Hello Intvl
DR
-----
ip-10.1.7.1              Up   Up   1           30
 10.1.7.7
ip-10.111.1.1            Up   Up   1           30
 10.111.1.1
-----
Interfaces : 2
=====
```

```
*A:7705:Dut-A# show router pim interface detail
=====
PIM Interface ipv4 ip-10.1.7.1
=====
Admin Status      : Up                Oper Status      : Up
IPv4 Admin Status : Up                IPv4 Oper Status : Up
```



```

DR : 10.1.7.7
Oper DR Priority : 1
BSM RA Check : Disabled
Hello Interval : 30
Hello Multiplier : 35
J/P Tracking Admin : Disabled
Auto-created : No
Sticky-DR : Disabled
Max Groups Allowed : 0
Num Groups : 5
Three-way Hello : Disabled
Instant Prune Echo : Disabled
Cfg DR Priority : 1
Time for next hello: 0d 00:00:16
J/P Tracking Oper : Disabled
Improved Assert : Enabled
Sticky-DR Priority : N/A
Max Groups Till Now: 5
Bfd enabled : No
Assert-Period : 60
    
```

-----  
PIM Group Source  
-----

```

Group Address : 239.255.0.0
Source Address : 10.111.1.2
Interface : ip-10.1.7.1 Type : (S,G)
RP Address : 10.0.0.0
Up Time : 0d 00:01:09
Join Prune State : Join Expires : 0d 00:03:21
Prune Pend Expires : N/A
    
```

Assert State : No Info  
-----

PIM Group Source  
-----

```

Group Address : 239.255.0.1
Source Address : 10.111.1.2
Interface : ip-10.1.7.1 Type : (S,G)
RP Address : 10.0.0.0
Up Time : 0d 00:01:10
Join Prune State : Join Expires : 0d 00:03:20
Prune Pend Expires : N/A
    
```

Assert State : No Info  
-----

PIM Group Source  
-----

```

Group Address : 239.255.0.2
Source Address : 10.111.1.2
Interface : ip-10.1.7.1 Type : (S,G)
RP Address : 10.0.0.0
Up Time : 0d 00:01:11
Join Prune State : Join Expires : 0d 00:03:19
Prune Pend Expires : N/A
    
```

Assert State : No Info  
-----

PIM Group Source  
-----

```

Group Address : 239.255.0.3
Source Address : 10.111.1.2
Interface : ip-10.1.7.1 Type : (S,G)
RP Address : 10.0.0.0
Up Time : 0d 00:01:11
Join Prune State : Join Expires : 0d 00:03:19
Prune Pend Expires : N/A
    
```

Assert State : No Info

```

-----
PIM Group Source
-----
Group Address      : 239.255.0.4
Source Address     : 10.111.1.2
Interface          : ip-10.1.7.1      Type           : (S,G)
RP Address         : 10.0.0.0
Up Time           : 0d 00:01:11

Join Prune State  : Join              Expires         : 0d 00:03:18
Prune Pend Expires : N/A

Assert State      : No Info
=====
PIM Interface ipv4 ip-10.111.1.1
=====
Admin Status      : Up                Oper Status     : Up
IPv4 Admin Status : Up                IPv4 Oper Status : Up
DR                : 10.111.1.1
Oper DR Priority   : 1
BSM RA Check      : Disabled          Cfg DR Priority  : 1
Hello Interval    : 30                Time for next hello: 0d 00:00:29
Hello Multiplier  : 35
J/P Tracking Admin : Disabled          J/P Tracking Oper : Disabled
Auto-created      : No                Improved Assert  : Enabled
Sticky-DR         : Disabled          Sticky-DR Priority : N/A
Max Groups Allowed : 0                Max Groups Till Now: 0
Num Groups        : 0                Bfd enabled      : No
Three-way Hello   : Disabled          Assert-Period    : 60
Instant Prune Echo : Disabled

-----
Interfaces : 2
=====

```

```

*A:7705:Dut-A# show router pim interface group
=====
PIM Interface ipv4 ip-10.1.7.1
=====
Interface          Adm  Opr  DR Prty      Hello Intvl
DR
-----
ip-10.1.7.1        Up   Up   1           30
 10.1.7.7

-----
Group Address      Type   JP      Assert
Source Address
RP Address
-----
239.255.0.0        (S,G)  Join    No Info
 10.111.1.2

239.255.0.1        (S,G)  Join    No Info
 10.111.1.2

239.255.0.2        (S,G)  Join    No Info
 10.111.1.2

239.255.0.3        (S,G)  Join    No Info
 10.111.1.2

239.255.0.4        (S,G)  Join    No Info
 10.111.1.2
-----

```

```

Interfaces : 1
=====

*A:7705:Dut-A# show router pim interface group 239.255.0.0 detail
=====
PIM Interface ipv4 ip-10.1.7.1
=====
Interface          Adm  Opr  DR Prty      Hello Intvl
DR
-----
ip-10.1.7.1        Up   Up   1          30
10.1.7.7
-----
PIM Group Source
-----
Group Address      : 239.255.0.0
Source Address     : 10.111.1.2
Interface          : ip-10.1.7.1      Type           : (S,G)
RP Address         : 10.0.0.0
Up Time           : 0d 00:11:09

Join Prune State   : Join                Expires         : 0d 00:03:21
Prune Pend Expires : N/A

Assert State       : No Info
-----
Interfaces : 1
=====
    
```

Table 19: PIM interface field descriptions

Label	Description
<b>PIM Interface</b>	
Admin Status	The administrative state for the PIM protocol on this interface
Oper Status	The current operational state of the PIM protocol on this interface
IPv4 Admin Status	The administrative state for the PIM protocol on this interface
IPv4 Oper Status	The current operational state of the PIM protocol on this interface
DR	The designated router on this PIM interface
Oper DR Priority	The priority of the operational designated router
BSM RA Check	Not applicable
Cfg DR Priority	The priority value sent in PIM Hello messages that is used by routers to elect the designated router (DR)
Hello Interval	The time interval at which PIM Hello messages are transmitted on this interface
Time for next hello	The time when the next PIM Hello message will be transmitted
Hello Multiplier	The value of the hello multiplier

Label	Description
J/P Tracking Admin	The administrative state for Join Prune message tracking: Enabled or Disabled
J/P Tracking Oper	The operational state for Join Prune message tracking: Enabled or Disabled
Auto-created	Specifies whether the PIM interface was auto-created: Yes or No
Improved Assert	Specifies whether the improved assert processing on this interface is Enabled or Disabled. The 7705 SAR supports only Enabled (that is, the PIM assert process is done entirely on the control plane with no interaction between the control and forwarding planes).
Sticky-DR	The configured state of sticky-DR: Enabled or Disabled
Sticky-DR Priority	Not applicable
Max Groups Allowed	The maximum number of groups allowed for this interface
Max Groups Till Now	The maximum number of groups joined for this interface up until the present time
Num Groups	The current number of groups joined for this interface
Bfd enabled	Specifies whether BFD is enabled: Yes or No
Three-way Hello	The state of the three-way hello parameter: Enabled or Disabled
Assert-Period	The period for refreshes of PIM Assert messages on an interface
Instant Prune Echo	The state of the instant prune echo: Enabled or Disabled
<b>PIM Group Source</b>	
Group Address	The group IP address for this PIM group
Source Address	The unicast source IP address for this PIM group
Interface	The PIM IP address for this PIM interface
Type	The type of multicast group
RP Address	The IP address of the rendezvous point for this PIM interface
Up Time	The time since this PIM interface joined the multicast group
Join Prune State	The Join Prune state for this PIM interface and multicast group
Expires	The length of time until this PIM interface leaves the multicast group
Prune Pend Expires	Not applicable

Label	Description
Assert State	The PIM assert message state

## multicast-translation type

### Syntax

**multicast-translation type** {unicast-to-multicast | multicast-to-multicast}

### Context

show>router>pim>interface

### Description

This command displays the translated addresses for either unicast-to-multicast translation or multicast-to-multicast translation.

## neighbor

### Syntax

**neighbor** [*ip-int-name* | *ip-address* [**address** *neighbor-ip-address*]] [**detail**] [*family*]

### Context

show>router>pim

### Description

This command displays PIM neighbor information.

This information can be important if an interface has more than one adjacency. For example, assume a LAN interface configuration has three routers connected and all the routers are running PIM on their LAN interfaces. These routers have two adjacencies on their LAN interface, each with different neighbors. If the **address** *neighbor-ip-address* parameter is not defined in this example, then the **show** command output would display two adjacencies instead of only the one adjacency of the neighbor whose IP address is specified.

### Parameters

*ip-int-name*

displays the interface information associated with the specified IP interface name

*ip-address*

displays the interface information associated with the specified IP address (IPv4 or IPv6)

*neighbor-ip-address*

the IP address of the PIM neighbor on the other side of the interface (IPv4 or IPv6)

**detail**

displays detailed interface information

*family*

displays IPv4 or IPv6 information for the interface

**Values**    ipv4 or ipv6

**Output**

The following output is an example of PIM neighbor information, and [Table 20: PIM neighbor field descriptions](#) describes the fields.

**Output example**

```
*A:7705custDoc:Sar18>show>router>pim# neighbor
=====
PIM Neighbor ipv4
=====
Interface          Nbr DR Prty   Up Time      Expiry Time  Hold Time
  Nbr Address
-----
ip-10.1.7.7        1             0d 00:29:49  0d 00:01:28  105
  10.1.7.1
ip-10.112.1.1      0             0d 00:28:44  0d 00:00:05   5
  10.112.1.2
ip-10.112.2.1      0             0d 00:28:44  0d 00:00:05   5
  10.112.2.2
ip-10.112.3.1      0             0d 00:28:43  0d 00:00:04   5
  10.112.3.2
ip-10.112.4.1      0             0d 00:28:43  0d 00:00:03   5
  10.112.4.2
-----
Neighbors : 5
=====
*A:7705custDoc:Sar18>show>router>pim# neighbor
```

```
*A:7CSA:Dut-C# show router pim neighbor ip-10.1.7.7
=====
PIM Neighbor ipv4
=====
Interface          Nbr DR Prty   Up Time      Expiry Time  Hold Time
  Nbr Address
-----
ip-10.1.7.7        1             0d 00:58:15  0d 00:01:31  105
  10.1.7.1
-----
Neighbors : 1
=====
```

```
*A:7CSA:Dut-C# show router pim neighbor ip-10.1.7.7 detail
=====
PIM Neighbor ipv4
=====
Interface          : ip-10.1.7.7
Neighbor Addr      : 10.1.7.1
DR Priority         : 1
Tracking Support   : No
Gen Id             : 60143787
Up Time            : 0d 01:00:13
LAN Delay(ms)     : 500
Override Intvl(ms): 2500
Expiry Time       : 0d 00:01:34
```

```
Hold Time(sec)      : 105
```

```
-----  
Secondary Neighbor Addresses  
-----  
-----
```

```
Neighbors : 1
```

Table 20: PIM neighbor field descriptions

Label	Description
Interface	The interface name of the neighbor
Nbr DR Priority	The value of the DR priority of the neighbor, which is received in the Hello message
Nbr Address	The IP address of the neighbor
Up Time	The time since this PIM neighbor (last) became a neighbor of the local router
Expiry Time	The minimum time remaining before this PIM neighbor will be aged out  A value of 0 (zero) means that this neighbor will never be aged out, which occurs when the PIM neighbor sends a Hello message with hold time set to 0xffff
Hold Time	The value of the hold time present in the Hello message
DR Priority	The value of the DR priority of the neighbor, which is received in the Hello message
Tracking Support	Indicates the presence of the T-bit in the LAN prune delay option in the Hello message: Yes or No, which indicates the neighbor's capability to disable join message suppression
LAN Delay (ms)	The value of the LAN delay field present in the Hello message received from the neighbor
Gen Id	A randomly generated 32-bit value that is regenerated each time PIM forwarding is started or restarted on the interface, including when the router itself restarts. When a Hello message with a new GenID is received from a neighbor, any old Hello information for that neighbor is discarded and superseded by the information from the new Hello message.
Override Intvl (ms)	The value of the override interval present in the Hello message

## rp

### Syntax

**rp** [*family* | *ip-address*]

### Context

show>router>pim

### Description

This command displays RP information that is learned through PIM bootstrap or configured statically.

### Parameters

*family*

displays either IPv4 or IPv6 information

**Values**    ipv4 or ipv6

**Default**    ipv4

*ip-address*

displays RP information associated with the specified IP address

### Output

The following output is an example of RP output information, and [Table 21: RP field descriptions](#) describes the fields.

#### Output example

```
*A: Sar18 Dut-B>show>router>pim# rp
=====
PIM RP Set ipv4
=====
Group Address          Type      Hold Expiry
  RP Address          Prio Time Time
-----
224.0.0.0/4
  10.200.200.4        Dynamic  192  150  N/A
  10.1.7.1            Static   1    N/A  N/A
=====
```

Table 21: RP field descriptions

Label	Description
Group Address	The multicast group address of the entry
RP Address	The IP address of the RP



Label	Description
Type	Indicates whether the entry was learned through the bootstrap mechanism or was statically configured
Prio	The priority for the specified group address. The higher the value, the higher the priority
Hold Time	The value of the hold time present in the BSM message
Expiry Time	The length of time until the entry expires

## rp-hash

### Syntax

**rp-hash** *ip-address*

### Context

show>router>pim

### Description

This command hashes the RP for the multicast group address associated with the specified IPv4 address.

### Parameters

*ip-address*

displays RP information for the multicast group associated with the specified IPv4 address

### Output

The following output is an example of RP hash output information, and [Table 22: RP hash field descriptions](#) describes the fields.

### Output example

```
*A: Sar18 Dut-B# show router pim rp-hash 239.255.0.0
=====
PIM Group-To-RP mapping
=====
Group Address      RP Address      Type
-----
239.255.0.0       239.255.200.4  Bootstrap
=====
*A: Sar18 Dut-B#
```

Table 22: RP hash field descriptions

Label	Description
Group Address	The multicast group address for the specified IP address

Label	Description
RP Address	The IP address of the RP
Type	Indicates whether the entry was learned through the bootstrap mechanism or was statically configured

## s-pmsi

### Syntax

**s-pmsi** [**detail**]

**s-pmsi** [*mdSrcAddr* [*mdGrpAddr*]] [**detail**]

**s-pmsi** **ext-tunnel-id** *ext-tunnel-id* [**tunnel-id** *tunnel-id*] [**detail**]

**s-pmsi** **root-addr** *root-addr* [**lsp-id** *lsp-id*] [**detail**]

### Context

show>router>pim

### Description

This command displays PIM S-PMSIs that are currently active.

### Parameters

#### detail

displays detailed information

#### *mdSrcAddr*

displays PIM S-PMSI information associated with the specified source address of the multicast sender

#### *mdGrpAddr*

displays PIM S-PMSI information associated with the specified group address of the multicast sender

#### *ext-tunnel-id*

displays PIM S-PMSI information associated with the specified external tunnel ID

#### *tunnel-id*

displays PIM S-PMSI information associated with the specified tunnel ID

#### *root-addr*

displays PIM S-PMSI information associated with the specified root address

### Output

The following output is an example of S-PMSI output information, and [Table 23: S-PMSI field descriptions](#) describes the fields.

**Output example**

```
*B:node-6# show router 100 pim s-psmi
=====
PIM Selective provider tunnels
=====
MD Src Address      MD Grp Address      MT Index      Num VPN SGs
-----
239.255.0.1        239.255.89.72      24603        1
239.255.0.2        239.255.89.73      24604        1
239.255.0.3        239.255.89.74      24605        1
239.255.0.4        239.255.89.75      24606        1
239.255.0.5        239.255.89.76      24607        1
239.255.0.6        239.255.89.77      24608        1
239.255.0.7        239.255.89.78      24609        1
239.255.0.8        239.255.89.79      24610        1
239.255.0.9        239.255.89.80      24611        1
239.255.0.10       239.255.89.81      24612        1
239.255.0.11       239.255.89.82      24613        1
239.255.0.12       239.255.89.83      24614        1
239.255.0.13       239.255.89.84      24615        1
239.255.0.14       239.255.89.85      24616        1
239.255.0.15       239.255.89.86      24617        1
239.255.0.16       239.255.89.87      24618        1
...
=====
*B:node-6#
```

```
*B:node-6# show router 100 pim s-psmi detail
=====
PIM Selective provider tunnels
=====
Md Source Address   : 239.255.0.1      Md Group Address   : 239.255.89.72
Number of VPN SGs  : 1                Uptime             : 0d 00:00:18
MT IfIndex         : 24603           Egress Fwding Rate : 163.2 kbps

VPN Group Address   : 239.255.0.0      VPN Source Address  : 10.2.102.1
State               : RX Joined
Expiry Timer        : 0d 00:02:41
=====
PIM Selective provider tunnels
=====
Md Source Address   : 239.255.0.2      Md Group Address   : 239.255.89.73
Number of VPN SGs  : 1                Uptime             : 0d 00:00:18
MT IfIndex         : 24604           Egress Fwding Rate : 163.2 kbps

VPN Group Address   : 239.255.0.1      VPN Source Address  : 10.2.102.1
State               : RX Joined
Expiry Timer        : 0d 00:02:41
=====
PIM Selective provider tunnels
=====
Md Source Address   : 239.255.0.4      Md Group Address   : 239.255.89.74
Number of VPN SGs  : 1                Uptime             : 0d 00:00:20
MT IfIndex         : 24605           Egress Fwding Rate : 165.7 kbps

VPN Group Address   : 239.255.0.2      VPN Source Address  : 10.2.102.1
State               : RX Joined
Expiry Timer        : 0d 00:02:39
=====
PIM Selective provider tunnels
=====
```

```

Md Source Address : 239.255.0.5      Md Group Address : 239.255.89.75
Number of VPN SGs : 1                Uptime           : 0d 00:00:20
MT IfIndex       : 24606              Egress Fwding Rate : 165.7 kbps

VPN Group Address : 239.255.0.3      VPN Source Address : 10.2.102.1
State             : RX Joined
Expiry Timer      : 0d 00:02:39
=====
*B:node-6#
    
```

Table 23: S-PMSI field descriptions

Label	Description
MD Grp Address	The IP multicast group address for which this entry contains information
MD Src Address	The source address of the multicast sender A value of 0 (zero) indicates that the type is configured as <b>starg</b> .
MT Index MT IfIndex	Displays the index number
Num VP SGs	Displays the number of VPN (S,G)s
Uptime	The length of time that the S-PMSI has been up
Egress Fwding Rate	he egress forwarding rate for the S-PMSI
VPN Group Address	The VPN group address for the S-PMSI
VPN Source Address	The VPN source address for the S-PMSI
Expiry Timer	The minimum time remaining before this S_PMSI will be aged out A value of 0 (zero) means that this S-PMSI will never be aged out, which occurs when the PIM neighbor sends a Hello message with hold time set to 0xffff

## statistics

### Syntax

**statistics** [*ip-int-name* | *ip-address*] [*family*]

### Context

show>router>pim

### Description

This command displays statistics for a particular PIM instance.

## Parameters

*ip-int-name*

displays the interface information associated with the specified IP interface name

*ip-address*

displays the interface information associated with the specified IP address

*family*

displays either IPv4 or IPv6 information

**Values**    ipv4 or ipv6

## Output

The following output is an example of PIM statistics output information, and [Table 24: PIM statistics field descriptions](#) describes the fields.

### Output example

```
*A:7CSA:Dut-C# show router pim statistics
=====
PIM Statistics ipv4
=====
Message Type           Received      Transmitted   Rx Errors
-----
Hello                  25435        2907          0
Join Prune             75796        79            0
Asserts                0            0            0
Register               0            0            0
Null Register         0            0            0
Register Stop         0            0            0
BSM                    0            0            0
Candidate RP Adv      0            0            0
Total Packets         101231       2986
-----
General Statistics
-----
Rx Invalid Register           : 0
Rx Neighbor Unknown           : 0
Rx Bad Checksum Discard       : 0
Rx Bad Encoding               : 0
Rx Bad Version Discard        : 0
Rx CRP No Router Alert        : 0
Rx BSM Router Alert Drops     : 0
Rx BSM Wrong If Drops         : 0
Rx Invalid Join Prune         : 0
Rx Unknown PDU Type           : 0
Join Policy Drops              : 0
Register Policy Drops          : 0
Bootstrap Import Policy Drops : 0
Bootstrap Export Policy Drops : 0
Fwd Candidate RP Adv          : 0
Fwd Candidate RP Adv Drops    : 0
-----
Source Group Statistics
-----
(S,G)                       : 64
(*,G)                        : 0
(*,*,RP)                     : 0
=====
```

Table 24: PIM statistics field descriptions

Label	Description
<b>PIM Statistics</b>	
Message Type	Hello – the number of PIM Hello messages received or transmitted on this interface Join Prune – the number of PIM Join Prune messages received or transmitted on this interface Asserts – the number of PIM Assert messages received or transmitted on this interface Register – the number of Register messages received or transmitted on this interface Null Register – the number of PIM Null Register messages received or transmitted on this interface Register Stop – the number of PIM Register Stop messages received or transmitted on this interface BSM – the number of PIM Bootstrap messages (BSM) received or transmitted on this interface Candidate RP Adv – the number of candidate RP advertisements Total Packets – the total number of packets transmitted and received on this interface
Received	The number of messages received on this interface
Transmitted	The number of multicast data packets transmitted on this interface
Rx Errors	The total number of receive errors
<b>General Statistics</b>	
Rx Invalid Register	The number of invalid PIM Register messages received on this interface
Rx Neighbor Unknown	The number of PIM messages (other than Hello messages) that were received on this interface and were rejected because the adjacency with the neighbor router was not already established
Rx Bad Checksum Discard	The number of PIM messages received on this interface that were discarded because of a bad checksum
Rx Bad Encoding	The number of PIM messages with bad encodings received on this interface
Rx Bad Version Discard	The number of PIM messages with bad versions received on this interface

Label	Description
Rx CRP No Router Alert	The number of candidate-rp advertisements (C-RP-Adv) received on this interface that had no router alert option set
Rx BSM Router Alert Drops	The number of router alert bootstrap message alerts that have been dropped on this interface
Rx BSM Wrong If Drops	The number of bootstrap messages not meant to be received on this interface
Rx Invalid Join Prune	The number of invalid PIM Join Prune messages received on this interface
Rx Unknown PDU Type	The number of packets received with an unsupported PIM type
Join Policy Drops	The number of times the join policy match resulted in dropping a PIM Join Prune message or one of the source groups contained in the message
Register Policy Drops	The number of times the register policy match resulted in dropping a PIM Register message
Bootstrap Import Policy Drops	The number of Bootstrap messages received on this interface that were dropped because of Bootstrap import policy
Bootstrap Export Policy Drops	The number of Bootstrap messages that were not transmitted on this interface because of Bootstrap export policy
Fwd Candidate RP Adv	The number of candidate RP advertisements that were forwarded by the router
Fwd Candidate RP Adv Drops	The number of candidate RP advertisements that were dropped by the router
<b>Source Group Statistics</b>	
(S,G)	The number of entries in which the type is (S,G)
(* ,G)	The number of entries in which the type is (* ,G)
(* ,*,RP)	The number of entries in which the type is (* , * , rp)

## status

### Syntax

**status** [detail] [family]

### Context

show>router>pim

## Description

This command displays the PIM status. The Oper Status indicates the combined operational status of IPv4/IPv6 PIM protocol status. If both are down, then Oper Status will be shown as down. If IPv4 or IPv6 is up, the Oper Status will indicate up.

If PIM is not enabled, the following message appears:

```
A:NYC# show router pim status
MINOR: CLI PIM is not configured.
A:NYC#
```

## Parameters

*family*

displays either IPv4 or IPv6 information

**Values** ipv4 or ipv6

**detail**

displays detailed status information

## Output

The following output is an example of PIM status information, and [Table 25: PIM status field descriptions](#) describes the fields.

### Output example

```
*A:7705:Dut-A# show router pim status detail ipv4
=====
PIM Status ipv4
=====
Admin State           : Up
Oper State            : Up

IPv4 Admin State     : Up
IPv4 Oper State      : Up

BSR State             : Accept Any

Elected BSR
  Address              : None
  Expiry Time          : N/A
  Priority              : N/A
  Hash Mask Length    : 30
  Up Time              : N/A
  RPF Intf towards E-BSR : N/A

Policy                : None

RPF Table             : rtable-u

Non-DR-Attract-Traffic : Disabled
=====
```

```
*A:7705:Dut-A# show router pim status detail ipv6
=====
PIM Status ipv6
=====
```



```

Admin State           : Up
Oper State           : Up

IPv6 Admin State     : Down
IPv6 Oper State      : Down

BSR State            : Accept Any

Elected BSR
  Address             : None
  Expiry Time        : N/A
  Priority            : N/A
  Hash Mask Length   : 126
  Up Time            : N/A
  RPF Intf towards E-BSR : N/A

Policy               : None

RPF Table            : rtable6-u

Non-DR-Attract-Traffic : Disabled
=====
    
```

Table 25: PIM status field descriptions

Label	Description
Admin State	The administrative status of PIM
Oper State	The current operating state of this PIM protocol instance
IPv4 Admin State IPv6 Admin State	The administrative status of PIM
IPv4 Oper State IPv6 Oper State	The current operating state of this PIM protocol instance
BSR State	The state of the router with respect to the Bootstrap mechanism
Elected BSR	Address – the address of the elected Bootstrap router Expiry Time – the time remaining before the router sends the next Bootstrap message Priority – the priority of the elected Bootstrap router. The higher the value, the higher the priority. Hash Mask Length – the hash mask length of the Bootstrap router Up Time – the time since the current E-BSR became the Bootstrap router RPF Intf towards E-BSR – the RPF interface toward the elected BSR. The value is zero if there is no elected BSR in the network.
Policy	The PIM policies for a particular PIM instance
RPF Table	The route table used for the RPF check

Label	Description
Non-DR-Attract-Traffic	Indicates whether the router ignores the designated router state and attracts traffic even when it is not the designated router

## msdp

### Syntax

**msdp**

### Context

show>router

### Description

This command enables the context to display MSDP information.

## group

### Syntax

**group** [*group-name*] [**detail**]

### Context

show>router>msdp

### Description

This command displays information about MSDP groups.

### Parameters

*group-name*

displays information for the specified group. If no *group-name* is specified, information for all groups is displayed.

**detail**

displays detailed MSDP group information

### Output

The following output is an example of MSDP group information, and [Table 26: MSDP group field descriptions](#) describes the fields.

### Output example

```
*A:ALA-48>show>router>msdp# group
```

```
=====
MSDP Groups
=====
```

```

Group Name          Mode      Act Srcs  Local Address
-----
main                Mesh-group  None      None
loop1               Mesh-group  None      None
loop2               Mesh-group  None      None
loop3               Mesh-group  None      None
loop4               Mesh-group  None      None
loop5               Mesh-group  None      None
-----
Groups : 6
=====
*A:ALA-48>show>router>msdp#

*A:ALA-48>show>router>msdp# group test
=====
MSDP Groups
=====
Group Name          Mode      Act Srcs  Local Address
-----
test                Mesh-group  50000     10.10.10.103
-----
Groups : 1
=====
*A:ALA-48>show>router>msdp#

*A:ALA-48>show>router>msdp# group test detail
=====
MSDP Groups
=====
Group Name          : test
-----
Local Address       : 10.10.10.103
Admin State         : Up
Receive Msg Rate    : None
Receive Msg Time    : None
Mode                : Mesh-group
Export Policy       : None Specified / Inherited
Import Policy       : None Specified / Inherited
SA Limit            : 50000
-----
Groups : 1
=====
*A:ALA-48>show>router>msdp#

```

Table 26: MSDP group field descriptions

Label	Description
Group Name	Displays the MSDP group name
Mode	Displays the mode of peers in the group, either Mesh-group or Standard
Act Srcs	Displays the configured maximum number of SA messages that will be accepted by MSDP
Local Address	Displays the local end of an MSDP session
Admin State	Displays the administrative state

Label	Description
Receive Msg Rate	Displays the rate that the messages are read from the TCP session
Receive Msg Time	Displays the time interval in which the number of MSDP messages set by the <b>receive-msdp-msg-rate</b> <i>number</i> parameter are read from the TCP session
Receive Msg Thd	Displays the configured threshold for the number of MSDP messages that can be processed before the MSDP message rate-limiting function is activated
SA Limit	Displays the SA message limit
Export Policy	Displays whether an export policy is configured or inherited
Import Policy	Displays whether an import policy is configured or inherited

## peer

### Syntax

**peer** [*ip-address*] [**group** *group-name*] [**detail**]

### Context

show>router>msdp

### Description

This command displays information about an MSDP peer.

### Parameters

*ip-address*

displays information for the peer with the specified IP address. If no IP address is specified, information for all MSDP peers is displayed.

*group-name*

displays information for peers in the specified group. If no *group-name* is specified, information for all MSDP peers display is displayed.

**detail**

displays detailed MSDP peer information

### Output

The following output is an example of MSDP peer information, and [Table 27: MSDP peer field descriptions](#) describes the fields.

### Output example

```
A:ALA-48# show router msdp peer
```

```

=====
MSDP Peers
=====
Peer          Local Address   State           Last State Change   SA Learnt
-----
10.20.1.1     10.20.1.6      Established 08/30/2002 03:22:13   1008
-----
Peers : 1
=====
A:ALA-48#

A:ALA-48# show router msdp peer detail
=====
MSDP Peers
-----
Peer Address      : 10.20.1.1
-----
Group Name        : None
Local Address     : 10.20.1.6
Last State Change : 08/30/2002 03:22:13 Last Act Src Limit : N/A
Peer Admin State  : Up           Default Peer       : No
Peer Connect Retry : 0             State              : Established
SA accepted       : 1008         SA received        : 709
State timer expires: 18          Peer time out      : 62
Active Source Limit: None         Receive Msg Rate   : 0
Receive Msg Time  : 0             Receive Msg Thd    : 0
Auth Status       : Disabled      Auth Key           : None
Export Policy     : None Specified / Inherited
Import Policy     : None Specified / Inherited
-----
Peers : 1
=====
A:ALA-48#

```

Table 27: MSDP peer field descriptions

Label	Description
Peer	Displays the IP address of the peer
Local Address	Displays the local IP address
State	Displays the current state of the peer
Last State Change	Displays the date and time of the peer’s last state change
SA Learnt	Displays the number of SAs learned through a peer

## source

### Syntax

**source** [*ip-address/mask*] [**type** {**configured** | **dynamic** | **both**}] [**detail**]

### Context

show>router>msdp

### Description

This command displays the discovery method for the specified multicast source. By default, all user-created sources are displayed.

### Parameters

*ip-address/mask*

specifies the IP address and mask for a multicast source

**Values** *ip-address* is in the format a.b.c.d  
*mask* range is from 1 to 32

**configured**

displays user-created sources

**dynamic**

displays dynamically created sources

**both**

displays both user-configured and dynamically created sources

**detail**

displays detailed MSDP source information

### Output

The following output is an example of MSDP source information and [Table 28: MSDP source field descriptions](#) describes the fields.

#### Output example

```
*A:7705:Dut-C# show router msdp source
=====
MSDP Sources
=====
Source          Type          SA Limit   Num Excd   Last Exceeded
-----
10.3.3.3/32     Configured   None       0          N/A
-----
Sources : 1
=====
*A:7705:Dut-C#
```

Table 28: MSDP source field descriptions

Label	Description
Source	Displays the IP address of the MSDP peer
Type	Displays the type of peer
SA Limit	Displays the local IP address
Num Excd	Displays the number of times the global active source limit has been exceeded

Label	Description
Last Exceeded	Displays the date and time of the last state change of the peer

## source-active

### Syntax

**source-active** [{group *ip-address* | local | originator *ip-address* | peer *ip-address* | source *ip-address* | group *ip-address* source *ip-address*}] [detail]

### Context

show>router>msdp

### Description

This command displays source-active (SA) messages accepted by MSDP.

### Parameters

**group** *ip-address*

displays information for the specified group IP address

**local**

displays information about local SA messages

**originator** *ip-address*

displays information for the specified originator IP address

**peer** *ip-address*

displays information for the specified peer IP address

**source** *ip-address*

displays information for the specified source IP address

**detail**

displays detailed MSDP SA information

### Output

The following output is an example of accepted MSDP SA messages information, and [Table 29: MSDP SA field descriptions](#) describes the fields.

#### Output example

```
A:ALA-48# show router msdp source-active
=====
MSDP Source Active Info
=====
Grp Address      Src Address      Origin RP        Peer Address     State Timer
-----
239.255.0.0     239.255.1.2     10.20.1.1       10.20.1.1       69
239.255.0.1     239.255.1.2     10.20.1.1       10.20.1.1       69
239.255.0.2     239.255.1.2     10.20.1.1       10.20.1.1       69
```

```

239.255.0.3    239.255.1.2    10.20.1.1    10.20.1.1    69
239.255.0.4    239.255.1.2    10.20.1.1    10.20.1.1    69
239.255.0.5    239.255.1.2    10.20.1.1    10.20.1.1    69
239.255.0.6    239.255.1.2    10.20.1.1    10.20.1.1    69
239.255.0.7    239.255.1.2    10.20.1.1    10.20.1.1    69
239.255.0.8    239.255.1.2    10.20.1.1    10.20.1.1    69
239.255.0.9    239.255.1.2    10.20.1.1    10.20.1.1    69
-----
MSDP Source Active : 10
=====
A:ALA-48#

A:ALA-48# show router msdp source-active detail
=====
MSDP Source Active
=====
Group Address      : 239.255.0.0      Source Address     : 10.112.1.2
Origin RP         : 10.20.1.1      Peer Address      : 10.20.1.1
State Timer       : 64          Up Time           : 3d 01:44:25
Group Address      : 239.255.0.1      Source Address     : 10.112.1.2
Origin RP         : 10.20.1.1      Peer Address      : 10.20.1.1
State Timer       : 64          Up Time           : 48d 18:22:29
Group Address      : 239.255.0.2      Source Address     : 10.112.1.2
Origin RP         : 10.20.1.1      Peer Address      : 10.20.1.1
State Timer       : 64          Up Time           : 48d 18:22:29
Group Address      : 239.255.0.3      Source Address     : 10.112.1.2
Origin RP         : 10.20.1.1      Peer Address      : 10.20.1.1
State Timer       : 64          Up Time           : 48d 18:22:29
Group Address      : 239.255.0.4      Source Address     : 10.112.1.2
Origin RP         : 10.20.1.1      Peer Address      : 10.20.1.1
State Timer       : 64          Up Time           : 48d 18:22:29
Group Address      : 239.255.0.5      Source Address     : 10.112.1.2
Origin RP         : 10.20.1.1      Peer Address      : 10.20.1.1
State Timer       : 64          Up Time           : 48d 18:22:29
Group Address      : 239.255.0.6      Source Address     : 10.112.1.2
Origin RP         : 10.20.1.1      Peer Address      : 10.20.1.1
State Timer       : 64          Up Time           : 48d 18:22:29
Group Address      : 239.255.0.7      Source Address     : 10.112.1.2
Origin RP         : 10.20.1.1      Peer Address      : 10.20.1.1
State Timer       : 64          Up Time           : 48d 18:22:29
Group Address      : 239.255.0.8      Source Address     : 10.112.1.2
Origin RP         : 10.20.1.1      Peer Address      : 10.20.1.1
State Timer       : 64          Up Time           : 48d 18:22:29
Group Address      : 239.255.0.9      Source Address     : 10.112.1.2
Origin RP         : 10.20.1.1      Peer Address      : 10.20.1.1
State Timer       : 64          Up Time           : 48d 18:22:29
-----
MSDP Source Active : 10
=====
A:ALA-48#

```

Table 29: MSDP SA field descriptions

Label	Description
Grp Address	Displays the IP address of the group
Src Address	Displays the IP address of the source
Origin RP	Displays the originating rendezvous point (RP) address



Label	Description
Peer Address	Displays the IP address of the peer
State Timer	Displays the state timeout value. If the value reaches 0, the SA entry is removed.

## source-active-rejected

### Syntax

**source-active-rejected** [*peer-group name*] [*group ip-address*] [*source ip-address*] [*originator ip-address*] [*peer ip-address*]

### Context

show>router>msdp

### Description

This command displays SA messages rejected by MSDP.

### Parameters

*name*

displays information about rejected SA messages for the specified peer group

**group** *ip-address*

displays information for the specified group IP address

**source** *ip-address*

displays information for the source address of the source-active entry that is rejected

**originator** *ip-address*

displays information for the specified originator IP address

**peer** *ip-address*

displays information for the peer from which this rejected source-active entry was last received

### Output

The following output is an example of rejected MSDP SA messages information, and [Table 30: MSDP source-active field descriptions](#) describes the fields.

### Output example

```
*A:ALA-48# show router msdp source-active-rejected
=====
MSDP Source Active Rejected Info
=====
Grp Address      Src Address      Origin RP        Peer Address     Reject Reason
-----
239.255.0.1     10.0.0.1        10.20.0.1       10.10.0.1       Import Policy
239.255.0.2     10.0.0.2        10.20.0.2       10.10.0.2       Export Policy
```

```

239.255.0.3    10.0.0.3    10.20.0.3    10.10.0.3    RPF Failure
239.255.0.4    10.0.0.4    10.20.0.4    10.10.0.4    Limit Exceeded
239.255.0.5    10.0.0.5    10.20.0.5    10.10.0.5    Limit Exceeded
239.255.0.6    10.0.0.6    10.20.0.6    10.10.0.6    Limit Exceeded
239.255.0.7    10.0.0.7    10.20.0.7    10.10.0.7    Limit Exceeded
-----
SA Rejected Entries : 7
=====
*A:ALA-48#
    
```

Table 30: MSDP source-active field descriptions

Label	Description
Grp Address	Displays the IP address of the group
Src Address	Displays the IP address of the source
Origin RP	Displays the originating rendezvous point (RP) address
Peer Address	Displays the address of the peer
Reject Reason	Displays the reason why this SA entry is rejected

## statistics

### Syntax

**statistics** [*peer ip-address*]

### Context

show>router>msdp

### Description

This command displays statistics information related to an MSDP peer.

### Parameters

*ip-address*

displays statistics for the peer with the specified IP address

### Output

The following output is an example of MSDP statistics information, and [Table 31: MSDP statistics field descriptions](#) describes the fields.

### Output example

```

A:ALA-48# show router msdp statistics
=====
MSDP Statistics
=====
Glo ActSrc Lim Excd: 0
    
```

```

-----
Peer Address      : 10.20.1.1
-----
Last State Change : 0d 11:33:16      Last message Peer : 0d 00:00:17
RPF Failures      : 0              Remote Closes      : 0
SA Msgs Sent      : 0              SA Msgs Recvd     : 709
SA req. Msgs Sent : 0              SA req. Msgs Recvd : 0
SA res. Msgs Sent : 0              SA res. Msgs Recvd : 0
KeepAlive Msgs Sent: 694          KeepAlive Msgs Recd: 694
Unknown Msgs Sent : 0              Error Msgs Recvd  : 0
-----
Peers : 1
=====
A:ALA-48#

```

Table 31: MSDP statistics field descriptions

Label	Description
Glo ActSrc Lim Excd	Displays the number of global active source messages that exceed the configured limit
Peer Address	Displays the address of the MSDP peer
Last State Change	Displays the date and time the peer state changed
Last message Peer	Displays the time the last message was received from the peer
RPF Failures	Displays the number of reverse path forwarding (RPF) failures
Remote Closes	Displays the number of times the remote peer closed
SA Msgs Sent	Displays the number of SA messages sent
SA Msgs Recvd	Displays the number of SA messages received
SA req. Msgs Sent	Displays the number of SA request messages sent
SA req. Msgs Recvd	Displays the number of SA request messages received
SA res. Msgs Sent	Displays the number of SA response messages sent
SA res. Msgs Recvd	Displays the number of SA response messages received
KeepAlive Msgs Sent	Displays the number of keepalive messages sent
KeepAlive Msgs Recd	Displays the number of keepalive messages received
Unknown Msgs Sent	Displays the number of unknown messages sent
Error Msgs Recvd	Displays the number of error messages received

## status

### Syntax

**status**

### Context

show>router>msdp

### Description

This command displays MSDP status information.

### Output

The following output is an example of MSDP status information, and [Table 32: MSDP status field descriptions](#) describes the fields.

#### Output example

```
A:ALA-48# show router msdp status
=====
MSDP Status
=====
Admin State                : Up
Local Address              : None
Global Statistics
Active Src Limit           : None
Act Src Lim Excd          : 0
Num. Peers                 : 1
Num. Peers Estab          : 1
Num. Source Active        : 10
Policies                   : None
Data Encapsulation        : Enabled
Receive Msg Rate
Rate                       : 0
Time                      : 0
Threshold                  : 0
Last Msdp Enabled         : 08/30/2002 03:21:43
=====
A:ALA-48#
```

*Table 32: MSDP status field descriptions*

Label	Description
Admin State	Displays the administrative state
Local Address	Displays the local IP address
Global Statistics	Displays global MSDP statistics
Active Src Limit	Displays the active source limit

Label	Description
Act Src Lim Excd	Displays the number of times that the active source limit was exceeded
Num. Peers	Displays the number of peers
Num. Peers Estab	Displays the number of peers established
Num. Source Active	Displays the number of active sources
Policies	Specifies the policy used to export the SA state from the SA list into MSDP
Data Encapsulation	Specifies whether the rendezvous point (RP) encapsulates multicast data received in MSDP register messages inside forwarded MSDP SA messages
Rate	The receive message rate
Time	The receive message interval
Threshold	The number of MSDP messages that can be processed before the MSDP message rate-limiting function is activated
Last Msdp Enabled	The time the last MSDP was triggered

### 3.19.2.3 Clear commands

#### igmp

##### Syntax

**igmp**

##### Context

clear>router

##### Description

This command enables the context to clear and reset IGMP entities.

#### database

##### Syntax

**database** [**interface** *ip-int-name* | *ip-address*] [**group** *grp-ip-address* [**source** *src-ip-address*]]

## Context

```
clear>router>igmp
```

## Description

This command clears IGMP database statistics on a specified interface or IP address.

## Parameters

*ip-int-name*

clears the IGMP database on the specified interface

*ip-address*

clears the IGMP database on the specified IP address

*grp-ip-address*

clears the multicast group address (ipv4) or zero address in the specified address group

*src-ip-address*

clears the IGMP database from the specified source IP address

## statistics

## Syntax

```
statistics [ip-int-name | ip-address]
```

## Context

```
clear>router>igmp
```

## Description

This command clears IGMP statistics on a specified interface or IP address.

An interface and group/source cannot be specified at the same time.

## Parameters

*ip-int-name*

clears IGMP statistics on the specified interface

*ip-address*

clears IGMP statistics on the specified IP address

## version

## Syntax

```
version [ip-int-name | ip-address]
```

## Context

```
clear>router>igmp
```

## Description

This command clears IGMP version parameters.

## Parameters

*ip-int-name*

clears version information for the specified IGMP interface name

*ip-address*

clears version information for the specified IGMP IP address

## mld

## Syntax

```
mld
```

## Context

```
clear>router
```

## Description

This command enables the context to clear and reset MLD entities.

## database

## Syntax

```
database [interface ip-int-name | ipv6-address] [group grp-ipv6-address [source src-ipv6-address]]
```

## Context

```
clear>router>mld
```

## Description

This command clears MLD database parameters.

## Parameters

*ip-int-name*

clears database information for the specified MLD interface name

*ipv6-address*

clears database information for the specified MLD interface IPv6 address

*grp-ipv6-address*

clears database information for the specified MLD group IPv6 address

*src-ipv6-address*

clears database information for the specified MLD source IP address

## statistics

### Syntax

**statistics** [*ip-int-name* | *ipv6-address*]

### Context

clear>router>mld

### Description

This command clears MLD statistics parameters.

### Parameters

*ip-int-name*

clears statistics for the specified MLD interface name

*ipv6-address*

clears statistics for the specified MLD IPv6 address

## version

### Syntax

**version** [*ip-int-name* | *ip-address*]

### Context

clear>router>mld

### Description

This command clears MLD version parameters.

### Parameters

*ip-int-name*

clears version information for the specified MLD interface name

*ip-address*

clears version information for the specified MLD IP address



## pim

### Syntax

pim

### Context

clear>router

### Description

This command enables the context to clear and reset PIM entities.

## database

### Syntax

**database** [**interface** *ip-int-name* | *ip-address*] [**group** *grp-ip-address* [**source** *src-ip-address*]] [*family*]

### Context

clear>router>pim

### Description

This command clears PIM database statistics on a specified interface or IP address.

### Parameters

*ip-int-name*

clears the PIM database on the specified interface

*ip-address*

clears the PIM database on the specified IP address

*grp-ip-address*

clears the multicast group address (ipv4/ipv6) or zero address in the specified address group

*src-ip-address*

clears the PIM database from the specified source IP address

*family*

clears either IPv4 or IPv6 information

**Values**    ipv4 or ipv6

## neighbor

### Syntax

**neighbor** [*ip-int-name*] [*family*]

### Context

clear>router>pim

### Description

This command clears PIM neighbor data on a specified interface or IP address.

### Parameters

*ip-int-name*

clears PIM neighbor data on the specified interface

*family*

clears either IPv4 or IPv6 information. If *family* is not specified, both IPv4 and IPv6 data are cleared.

**Values**    ipv4 or ipv6

## statistics

### Syntax

**statistics** [*family*]

**statistics interface** *ip-int-name* | *ip-address* [*family*]

**statistics group** *grp-ip-address* [**source** *ip-address*] [*family*]

### Context

clear>router>pim

### Description

This command clears PIM statistics.

### Parameters

*ip-int-name*

clears PIM statistics on the specified interface

**interface** *ip-address*

clears PIM statistics on the specified IP address

**grp-ip-address**

specifies a multicast group address (IPv4 or IPv6 or zero address). When the group address is specified along with the source address, then the (S,G) statistics are reset to zero.

**source ip-address**

specifies a source or RP address (IPv4 or IPv6). When the source address is specified along with the group address, then the (S,G) statistics are reset to zero.

**family**

clears either IPv4 or IPv6 information. If *family* is not specified, both IPv4 and IPv6 data are cleared.

**Values**    ipv4 or ipv6

**msdp****Syntax**

**msdp**

**Context**

clear>router

**Description**

This command enables the context to clear and reset Multicast Source Discovery Protocol (MSDP) entities and statistics.

**cache****Syntax**

**cache** [**peer** *ip-address*] [**group** *ip-address*] [**source** *ip-address*] [**originrp** *ip-address*]

**Context**

clear>router>msdp

**Description**

This command clears IP addresses from the MSDP cache.

**Parameters****peer ip-address**

clears the specified peer address

**group ip-address**

clears the specified group address

**source** *ip-address*

clears the specified source address

**originrp** *ip-address*

clears the specified originating rendezvous point (RP) address

## statistics

### Syntax

**statistics** [**peer** *ip-address*]

### Context

clear>router>msdp

### Description

This command clears IP address statistics for the peer to which MSDP SA requests for groups matching this entry's group range were sent.

### Parameters

*ip-address*

clears the MSDP statistics for the specified IP address

## 3.19.2.4 Monitor commands

## group

### Syntax

**group** *grp-ip-address* [**source** *ip-address*] [**interval** *interval*] [**repeat** *repeat*] [**absolute** | **rate**]

### Context

monitor>router>pim

### Description

This command monitors statistics for a PIM source group.

### Parameters

*grp-ip-address*

the IP address of a multicast group that identifies a set of recipients that are interested in a particular data stream

**Values** IPv4 or IPv6 address | 0

*ip-address*

the source or RP IP address to use in the ping requests

**Values** IPv4 or IPv6 address

**Default** 0.0.0.0 to 255.255.255.255

*interval*

specifies the interval for each display, in seconds

**Values** 10 | 20 | 30 | 40 | 50 | 60

**Default** 10

*repeat*

specifies the number of times the command is repeated

**Values** 1 to 999

**Default** 10

**absolute**

displays raw statistics, without processing. No calculations are performed on the delta or rate statistics.

**rate**

displays the rate per second for each statistic, instead of the delta

### 3.19.2.5 Debug commands

- [Debug IGMP commands](#)
- [Debug MLD commands](#)
- [Debug PIM commands](#)
- [Debug MSDP commands](#)
- [Debug Mtrace commands](#)

#### 3.19.2.5.1 Debug IGMP commands

igmp

**Syntax**

igmp

**Context**

debug>router

## Description

This command enables access to the IGMP debug commands.

## interface

### Syntax

**[no] interface** [*ip-int-name* | *ip-address*]

### Context

debug>router>igmp

## Description

This command enables debugging for IGMP interfaces.

The **no** form of the command disables the IGMP interface debugging for the specified interface name or IP address.

### Parameters

*ip-int-name*

displays the information associated with the specified IP interface name

*ip-address*

displays the information associated with the specified IP address

## misc

### Syntax

**[no] misc**

### Context

debug>router>igmp

## Description

This command enables debugging for IGMP miscellaneous information.

The **no** form of the command disables the debugging.

## packet

### Syntax

**[no] packet** [*query* | *v1-report* | *v2-report* | *v3-report* | *v2-leave*] [*ip-int-name* | *ip-address*]

## Context

```
debug>router>igmp
```

## Description

This command enables debugging for IGMP packets.

The **no** form of the command disables the debugging.

## Parameters

### **query**

specifies to log the IGMP group- and source-specific queries transmitted and received on this interface

### **v1-report**

specifies to log IGMPv1 reports transmitted and received on this interface

### **v2-report**

specifies to log IGMPv2 reports transmitted and received on this interface

### **v3-report**

specifies to log IGMPv3 reports transmitted and received on this interface

### **v2-leave**

specifies to log the IGMP Leaves transmitted and received on this interface

### *ip-int-name*

displays the information associated with the specified IP interface name

### *ip-address*

displays the information associated with the specified IP address

## 3.19.2.5.2 Debug MLD commands

```
mld
```

## Syntax

```
mld
```

## Context

```
debug>router
```

## Description

This command enables access to the MLD debug commands.

## interface

### Syntax

**[no] interface** [*ip-int-name* | *ipv6-address*]

### Context

debug>router>mld

### Description

This command enables debugging for MLD interfaces.

The **no** form of the command disables the MLD interface debugging for the specified interface name or IP address.

### Parameters

*ip-int-name*

displays the information associated with the specified IP interface name

*ipv6-address*

displays the information associated with the specified IP address

## misc

### Syntax

**[no] misc**

### Context

debug>router>mld

### Description

This command enables debugging for MLD miscellaneous information.

The **no** form of the command disables the debugging.

## packet

### Syntax

**[no] packet** [*query* | *v1-report* | *v2-report* | *v1-done*] [*ip-int-name* | *ipv6-address*]

### Context

debug>router>mld



## Description

This command enables debugging for MLD packets.

The **no** form of the command disables the debugging.

## Parameters

### **query**

specifies to log the MLD group- and source-specific queries transmitted and received on this interface

### **v1-report**

specifies to log MLDv1 reports transmitted and received on this interface

### **v2-report**

specifies to log MLDv2 reports transmitted and received on this interface

### **v1-done**

specifies to log the MLDv1 Done transmitted and received on this interface

### *ip-int-name*

displays the information associated with the specified IP interface name

### *ipv6-address*

displays the information associated with the specified IPv6 address

## 3.19.2.5.3 Debug PIM commands

```
pim
```

## Syntax

```
pim
```

## Context

```
debug>router
```

## Description

This command enables access to the PIM debug commands.

```
adjacency
```

## Syntax

```
[no] adjacency
```

## Context

```
debug>router>pim
```

## Description

This command enables debugging for PIM adjacencies. The **no** form of the command disables debugging.

**all**

## Syntax

**all** [**group** *grp-ip-address*] [**source** *ip-address*] [**detail**]

**no all**

## Context

debug>router>pim

## Description

This command enables debugging for all the PIM groups. The **no** form of the command disables debugging.

## Parameters

*grp-ip-address*

debugs information associated with all PIM groups for the specified multicast group address

**Values** IPv4 or IPv6 address

*ip-address*

debugs information associated with all PIM groups for the specified source address

**Values** IPv4 or IPv6 address

**detail**

debugs detailed information for all PIM groups

**assert**

## Syntax

**assert** [**group** *grp-ip-address*] [**source** *ip-address*] [**detail**]

**no assert**

## Context

debug>router>pim

## Description

This command enables debugging for the PIM assert mechanism. The **no** form of the command disables debugging.

## Parameters

### *grp-ip-address*

debugs information associated with the PIM assert mechanism for the specified multicast group address

**Values** IPv4 or IPv6 address

### *ip-address*

debugs information associated with the PIM assert mechanism for the specified source address

**Values** IPv4 or IPv6 address

### **detail**

debugs detailed information for the PIM assert mechanism

## auto-rp

### Syntax

**auto-rp** [**detail**]

**no auto-rp**

### Context

debug>router>pim

### Description

This command enables debugging for PIM auto-RP. The **no** form of the command disables debugging.

### Parameters

#### **detail**

debugs detailed information for the PIM auto-RP mechanism

## bgp

### Syntax

**bgp** [**source** *src-ip-address*] [**group** *grp-ip-address*] [**peer** *peer-ip-address*]

**no bgp**

### Context

debug>router>pim

### Description

This command enables debugging for the PIM BGP mechanism. The **no** form of the command disables debugging.

## Parameters

### *grp-ip-address*

debugs PIM BGP information associated with the specified group IP address

**Values** IPv4 or IPv6 address

### *peer-ip-address*

debugs PIM BGP information associated with the specified peer IP address

**Values** IPv4 or IPv6 address

### *src-ip-address*

debugs PIM BGP information associated with the specified source IP address

**Values** IPv4 or IPv6 address

### **detail**

debugs detailed PIM BGP information

## bsr

## Syntax

**bsr** [**detail**]

**no bsr**

## Context

debug>router>pim

## Description

This command enables debugging for the PIM Bootstrap mechanism. The **no** form of the command disables debugging.

## Parameters

### **detail**

debugs detailed information for the PIM bootstrap mechanism

## data

## Syntax

**data** [**group** *grp-ip-address*] [**source** *ip-address*] [**detail**]

**no data**

## Context

debug>router>pim

## Description

This command enables debugging for the PIM data exception. The **no** form of the command disables debugging.

## Parameters

*grp-ip-address*

debugs information associated with the PIM data exception for the specified multicast group address

**Values** IPv4 or IPv6 address

*ip-address*

debugs information associated with the PIM data exception for the specified source address

**Values** IPv4 or IPv6 address

**detail**

debugs detailed information for the PIM data exception

db

## Syntax

**db** [**group** *grp-ip-address*] [**source** *ip-address*] [**detail**]

**no db**

## Context

debug>router>pim

## Description

This command enables debugging for the PIM database. The **no** form of the command disables debugging.

## Parameters

*grp-ip-address*

debugs information associated with the PIM database for the specified multicast group address

**Values** IPv4 or IPv6 address or zero address

*ip-address*

debugs information associated with the PIM database for the specified source address

**Values** IPv4 or IPv6 address

**detail**

debugs detailed information for the PIM database

## interface

### Syntax

**interface** [*ip-int-name* | *int-ip-address*] [**detail**]

**no interface**

### Context

debug>router>pim

### Description

This command enables debugging for the PIM interface. The **no** form of the command disables debugging.

### Parameters

*ip-int-name*

debugs information associated with the specified IP interface name

**Values** IPv4 or IPv6 address

*int-ip-address*

debugs information associated with the specified IP address

**Values** IPv4 or IPv6 address

**detail**

debugs detailed information for the IP interface

## jp

### Syntax

**jp** [**group** *grp-ip-address*] [**source** *ip-address*] [**detail**]

**no jp**

### Context

debug>router>pim

### Description

This command enables debugging for the PIM join-prune mechanism. The **no** form of the command disables debugging.

### Parameters

*grp-ip-address*

debugs information associated with the specified PIM join-prune mechanism

**Values** IPv4 or IPv6 address or zero address

*ip-address*

debugs information associated with the specified PIM join-prune mechanism

**Values** IPv4 or IPv6 address

**detail**

debugs detailed information for the PIM join-prune mechanism

## mrrib

### Syntax

**mrrib** [**group** *grp-ip-address*] [**source** *ip-address*] [**detail**]

**no mrrib**

### Context

debug>router>pim

### Description

This command enables debugging for the PIM MRIB. The **no** form of the command disables debugging.

### Parameters

*grp-ip-address*

debugs information associated with the specified PIM MRIB

**Values** IPv4 or IPv6 address

*ip-address*

debugs information associated with the specified PIM MRIB

**Values** IPv4 or IPv6 address

**detail**

debugs detailed information for PIM MRIBs

## msg

### Syntax

**msg** [**detail**]

**no msg**

### Context

debug>router>pim

## Description

This command enables debugging for PIM messaging. The **no** form of the command disables debugging.

## Parameters

### detail

debugs detailed information for PIM messaging

## packet

## Syntax

**packet** [**hello** | **register** | **register-stop** | **jp** | **bsr** | **assert** | **crp**] [*ip-int-name* | *int-ip-address*]

**no packet**

## Context

debug>router>pim

## Description

This command enables debugging for PIM packets. The **no** form of the command disables debugging.

## Parameters

### *ip-int-name*

debugs information associated with the specified IP interface name

**Values** IPv4 or IPv6 interface name

### *int-ip-address*

debugs information associated with the specified IP address of a particular packet type

## red

## Syntax

**[no] red** [**detail**]

## Context

debug>router>pim

## Description

This command enables debugging for the PIM redundancy mechanism. The **no** form of the command disables debugging.



## Parameters

### detail

debugs detailed information for the PIM redundancy mechanism

## register

## Syntax

**register** [group *grp-ip-address*] [source *ip-address*] [**detail**]

**no register**

## Context

debug>router>pim

## Description

This command enables debugging for the PIM register mechanism. The **no** form of the command disables debugging.

## Parameters

### *grp-ip-address*

debugs information associated with the specified PIM register

**Values** IPv4 or IPv6 address

### *ip-address*

debugs information associated with the specified PIM register

**Values** IPv4 or IPv6 address

### **detail**

debugs detailed information for the PIM register mechanism

## rtm

## Syntax

**rtm** [**detail**]

**no rtm**

## Context

debug>router>pim

## Description

This command enables debugging for the PIM RTM. The **no** form of the command disables debugging.

**Parameters****detail**

debugs detailed information for the PIM RTM

**3.19.2.5.4 Debug MSDP commands****msdp****Syntax**

**[no] msdp**

**Context**

debug>router

**Description**

This command enables debugging for Multicast Source Discovery Protocol (MSDP).

The **no** form of the command disables MSDP debugging.

**packet****Syntax**

**packet** [*pkt-type*] [**peer** *ip-address*]

**Context**

debug>router>msdp

**Description**

This command enables debugging for MSDP packets.

The **no** form of the command disables MSDP packet debugging.

**Parameters***pkt-type*

debugs information associated with the specified packet type

**Values** keep-alive, source-active, sa-request, sa-response

*ip-address*

debugs information associated with the specified peer IP address

## pim

### Syntax

**pim** [*grp-address*]

**no pim**

### Context

debug>router>msdp

### Description

This command enables debugging for MSDP PIM.

The **no** form of the command disables MSDP PIM debugging.

### Parameters

*grp-address*

debugs the IP multicast group address for which this entry contains information

## rtm

### Syntax

**rtm** [*rp-address*]

**no rtm**

### Context

debug>router>msdp

### Description

This command enables debugging for MSDP route table manager (RTM).

The **no** form of the command disables MSDP RTM debugging.

### Parameters

*rp-address*

debugs the IP multicast address for which this entry contains information

## sa-db

### Syntax

**sa-db** [**group** *grpAddr*] [**source** *srcAddr*] [**rp** *rpAddr*]

**no sa-db**

**Context**

```
debug>router>msdp
```

**Description**

This command enables debugging for MSDP source-active (SA) requests. The **no** form of the command disables the MSDP SA database debugging.

**Parameters**

*grpAddr*

debugs the IP address of the group

*srcAddr*

debugs the source IP address

*rpAddr*

debugs the specified rendezvous point RP address

### 3.19.2.5.5 Debug Mtrace commands

#### mtrace

**Syntax**

```
[no] mtrace
```

**Context**

```
debug>router
```

**Description**

This command enables access to the mtrace debug commands. The **no** form of the command disables the debugging.

#### misc

**Syntax**

```
[no] misc
```

**Context**

```
debug>router>mtrace
```

**Description**

This command enables debugging for mtrace miscellaneous events. The **no** form of the command disables the debugging.

## packet

### Syntax

[no] packet [query | request | response]

### Context

debug>router>mtrace

### Description

This command enables debugging for mtrace packets.

The **no** form of the command disables the debugging.

### Parameters

#### query

specifies to log the mtrace queries transmitted and received

#### request

specifies to log the mtrace requests transmitted and received

#### response

specifies to log the mtrace responses transmitted and received

## 4 OSPF

This chapter provides information about configuring the Open Shortest Path First (OSPF) protocol.

Topics in this chapter include:

- [Overview of OSPF](#)
- [Bidirectional forwarding detection \(BFD\) for OSPF](#)
- [Graceful restart helper](#)
- [LFA protection using segment routing backup node SID](#)
- [LDP and IP fast reroute \(FRR\) for OSPF prefixes](#)
- [Preconfiguration requirements](#)
- [OSPF configuration process overview](#)
- [Configuration notes](#)
- [Configuring OSPF with CLI](#)
- [OSPF command reference](#)

### 4.1 Overview of OSPF

OSPF (Open Shortest Path First) is an interior gateway protocol (IGP) that is used within large autonomous systems (ASs). An autonomous system is a group of networks and network equipment under a common administration. OSPF is a link-state protocol; each router maintains an identical database (called the link-state database, topological database, or routing information database [RIB]) of the AS, including information about the local state of each router (for example, its usable interfaces and reachable neighbors).

OSPF-TE (OSPF with traffic engineering extensions) is used to advertise reachability information and traffic engineering information such as bandwidth. OSPF routers exchange status, cost, and other relevant interface information with neighboring routers. The information exchange enables all participating routers to establish their link-state database.

OSPF uses a cost metric that represents the status of the link and the bandwidth of the interface in an algorithm to determine the best route to a destination. The algorithm used is called the SPF (shortest path first) or Dijkstra algorithm. Path selection is based on lowest cost, which might not necessarily be the shortest route but is the best route in regards to bandwidth. Each router applies the algorithm to calculate the shortest path to each destination in the network.

When the best route to a particular destination is determined, the route information is sent to the routing table manager (RTM). The RTM may contain more than one best route to a destination from multiple protocols. Because metrics from different protocols are not comparable, the RTM uses preference to select the best route. The route with the lowest preference value is selected. For more information, see [Configuring route preferences](#).

The best routes from the RTM are then added to the forwarding table (also known as the forwarding database [or FIB]). All forwarding decisions are based on the information in the forwarding database.

The forwarding (or dropping) of packets is controlled by filters applied to the interface and route policies applied to the OSPF protocol. See the 7705 SAR Router Configuration Guide for information about filters and route policies.

The 7705 SAR implementation of OSPF conforms to OSPF Version 2 specifications presented in RFC 2328, *OSPF Version 2* and OSPF Version 3 specifications presented in RFC 2740, *OSPF for IPv6*. Routers running OSPF can be enabled with minimal configuration. All default and command parameters can be modified.

Changes between OSPF for IPv4 and OSPFv3 for IPv6 include the following.

- Addressing semantics have been removed from OSPF packets and the basic link-state advertisements (LSAs). New LSAs have been created to carry IPv6 addresses and prefixes.
- OSPFv3 runs on a per-link basis, instead of on a per-IP-subnet basis.
- Flooding scope for LSAs has been generalized.
- Unlike OSPFv2, OSPFv3 authentication relies on IPV6's authentication header and encapsulating security payload.
- Most packets in OSPF for IPv6 are almost as compact as those in OSPF for IPv4, even with the larger IPv6 addresses.
- Most field and packet-size limitations present in OSPF for IPv4 have been relaxed.
- Option handling has been made more flexible.

The following major OSPF features are supported:

- areas – backbone, super backbone, stub, and not-so-stubby areas (NSSAs)
- virtual links
- neighbors and adjacencies
- link-state advertisements (LSAs)
- metrics
- authentication (OSPFv2 only)
- route redistribution and summarization
- OSPF traffic engineering (TE) extensions (to track and advertise available bandwidth (OSPFv2 only)– used by MPLS traffic engineering; that is, RSVP-TE)

### 4.1.1 OSPF areas

An autonomous system can be divided into areas, with each area containing a group of networks. An area's topology is concealed from the rest of the AS, which significantly reduces OSPF protocol traffic (LSA updates), simplifies the network topology, and simplifies the routing table by populating it with summarized routes instead of exact routes on each router. This decrease in LSA updates, link-state database size, and CPU time, all required for OSPF route calculations, results in a decrease in route calculation time.

All routers in an area have identical link-state databases for that area.

Areas within the same AS are linked to each other via area border routers (ABRs). An ABR is a router that belongs to, and passes reachability information between, more than one OSPF area. An ABR maintains a separate topological database for each area it is connected to.

Routing in the AS takes place on two levels, depending on whether the source and destination of a packet reside in the same area (intra-area routing) or different areas (inter-area routing). In intra-area routing, the

packet is routed solely on information obtained within the area; that is, routing updates are only passed within the area. In inter-area routing, routing updates are passed between areas.

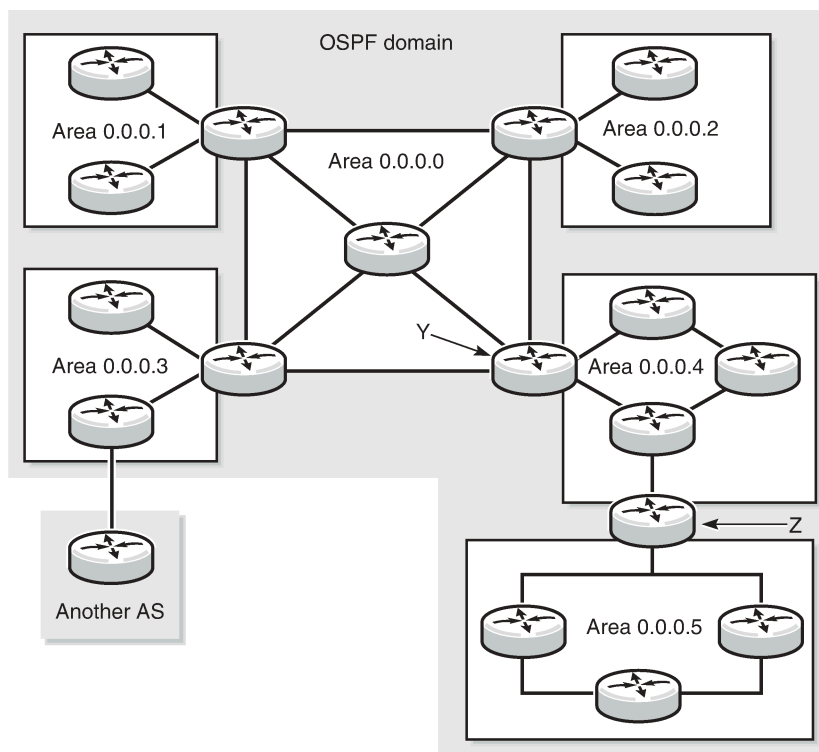
External routes refer to routing updates passed from another routing protocol into the OSPF domain.

Routers that pass information between an OSPF routing domain and a non-OSPF network are called autonomous system boundary routers (ASBRs).

### 4.1.1.1 Backbone area

Every OSPF system requires a backbone area. The OSPF backbone area is uniquely identified as area 0 and uses the area ID 0.0.0.0. All other areas must be connected to the backbone area, either physically or logically. The backbone distributes routing information between areas. If it is not practical or possible to connect an area to the backbone (see area 0.0.0.5 in the following figure), the ABRs (routers Y and Z in the figure) must be connected via a virtual link. The two ABRs form a point-to-point-like adjacency across the transit area (area 0.0.0.4).

Figure 11: Backbone area



20105

### 4.1.1.2 Super backbone area



**Note:** The super backbone is only supported under the VPRN OSPF context.



The 7705 SAR supports a version of the BGP/OSPF interaction procedures as defined in RFC 4577, *OSPF as the Provider/Customer Edge Protocol for BGP/MPLS IP Virtual Private Networks (VPNs) (support for basic OSPF at PE-CE links)*, to provide an MPLS VPN super backbone area. The BGP/OSPF interaction procedures that are supported as part of the super backbone include the following:

- loop prevention
- handling LSAs received from the CE
- sham links
- managing VPN-IPv4 routes received by BGP

The MPLS VPN super backbone functions like an additional layer of hierarchy in OSPF. The PE routers that connect the OSPF areas to the super backbone function as OSPF ABRs in the OSPF areas to which they are attached. In order to achieve full compatibility, the PE routers can also function as ASBRs in NSSAs.

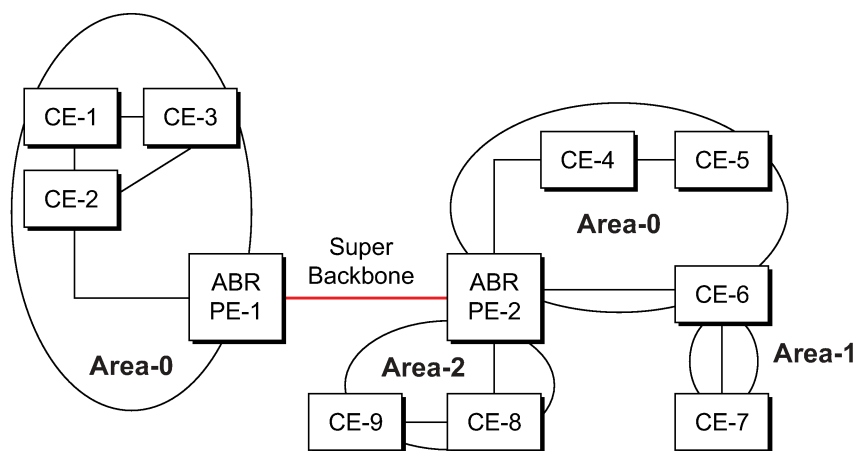
VPRN routes can be distributed among PE routers by BGP. If a PE router uses OSPF to distribute routes to a CE router, the standard procedures governing BGP/OSPF interactions cause routes from one site to be delivered to another site in type 5 LSAs as AS-external routes.

The PE routers insert inter-area routes from other areas into the area where a CE router is present. The CE routers are not involved at any level, nor are they aware of the super backbone or of other OSPF areas present beyond the MPLS VPN super backbone.

The CE always assumes that the PE is an ABR:

- If the CE is in the backbone, then the CE assumes that the PE is an ABR linking one or more areas to the backbone.
- If the CE is not in the backbone, the CE assumes that the backbone is on the other side of the PE.
- Therefore, the super backbone looks like another area to the CE.

Figure 12: PE routers connected to an MPLS VPN super backbone



36682

In [Figure 12: PE routers connected to an MPLS VPN super backbone](#), the PE routers are connected to the MPLS VPN super backbone. In order to be able to distinguish if two OSPF instances are the same and require type 3 LSAs to be generated or if they are two separate routing instances that require type 5 external LSAs to be generated, the concept of a domain ID is used.

The domain ID is carried with the MP-BGP update message and indicates the source OSPF domain. When the routes are being redistributed into the same OSPF domain, the concepts of a super backbone described previously are applied and type 3 LSAs are generated. If the OSPF domain does not match the domain ID, the route type will be external.

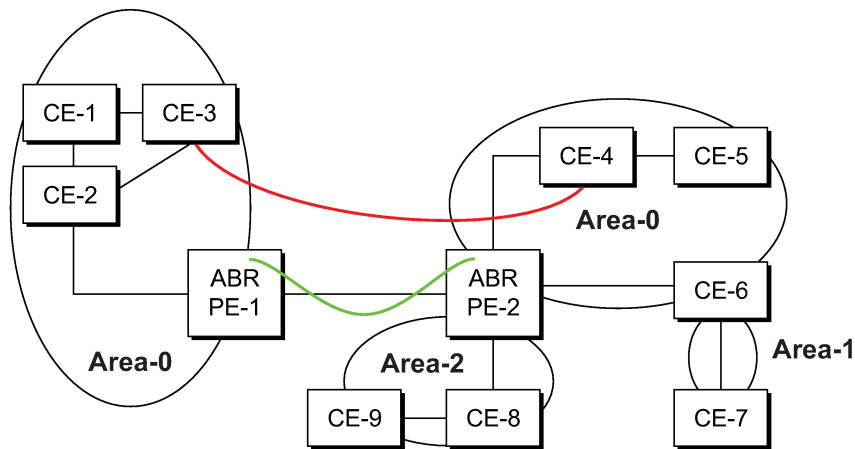
When configuring the super backbone, all destinations learned by PEs with matching domain IDs become inter-area routes.

When configuring sham links, the links become intra-area routes if they are in the same area.

#### 4.1.1.2.1 Sham link

A sham link is a logical PE-to-PE unnumbered point-to-point interface that rides over the PE-to-PE transport tunnel. A sham link can be associated with any area and can appear as an intra-area link to CE routers attached to different PEs in a VPN.

Figure 13: Sham link



36683

In [Figure 13: Sham link](#), the link between CE routers CE-3 and CE-4 (shown in red) is a low-speed OC-3/STM-1 link. Because the link establishes an intra-area route connection (backdoor link) between the CE-3 and CE-4 routers, a potential high-speed connection between PE routers PE-1 and PE-2 will not be utilized because OSPF always prefers intra-area links over inter-area links. Even as part of a super backbone configuration, the link between the PE routers is regarded as an inter-area connection.

To prevent the backdoor link from always being the preferred path, a sham link (shown in green) is also constructed as an inter-area link between PE routers. A normal OSPF adjacency is formed and the link-state database is exchanged across the MPLS VPN. As a result, the desired intra-area connectivity is created, and the cost of the sham link and backdoor link can be managed so that the backdoor link becomes a standby link and is used only if the sham link fails.



**Note:** A sham link is only required with an MPLS VPN configuration if a backdoor link is present.

### 4.1.1.2.2 Implementing the OSPF super backbone

With the OSPF super backbone architecture, the continuity of OSPF routing is preserved:

- The OSPF intra-area type 1 and type 2 LSAs advertised by the CE are inserted into the MPLS VPN super backbone by redistributing the OSPF route into MP-BGP by the PE adjacent to the CE.
- The MP-BGP route is propagated to other PE routers and inserted as an OSPF route into other OSPF areas. Because the PEs across the super backbone always act as ABRs, they will generate inter-area route OSPF summary type 3 LSAs.
- The inter-area route can now be propagated to other OSPF areas by other customer-owned ABRs within the customer site.
- Customer area 0 (backbone) routes appear as type 3 LSAs when carried across the MPLS VRN using MP-BGP even if the customer area remains area 0.

A BGP extended community (OSPF domain ID) provides the source domain of the route. This domain ID is not carried by OSPF but is carried by MP-BGP as an extended community attribute.

If the configured extended community value matches the receiving OSPF domain, the OSPF super backbone is implemented.

From a BGP perspective, the cost is copied into the MED attribute. For information about the MED attribute, see [MED attribute](#).

### 4.1.1.2.3 Loop avoidance

If a route sent from a PE router to a CE router is then be received by another PE router from one of its own CE routers, routing loops may occur. RFC 4577 specifies several methods of loop avoidance.

### 4.1.1.2.4 DN bit

When a type 3 LSA is sent from a PE router to a CE router, the DN bit in the LSA options field is set. This ensures that if any CE router sends the type 3 LSA to a PE router, the PE router does not redistribute it.

### 4.1.1.2.5 VPN route tag

If a particular VRF in a PE is associated with OSPF, then by default the VRF is configured with a special OSPF route tag value called the VPN route tag. This route tag is included in the type 5 LSAs that the PE originates and sends to any of the attached CEs. The configuration and inclusion of the VPN route tag is required for backward compatibility with implementations that do not set the DN bit in type 5 LSAs.

### 4.1.1.3 Area border router

Areas within the same AS are linked to each other via ABRs. An ABR is a router that belongs to, and passes reachability information between, more than one area. An ABR maintains a separate topological database for each area it is connected to.

A base router OSPF instance assumes an ABR role if it is actively attached to two or more different areas with at least one operationally up interface, and one of the attached areas is area 0.

If an ABR has an area 0 adjacency, it always calculates inter-area routes using only backbone summary LSAs. A router connected to multiple areas without an area 0 adjacency calculates inter-area routes using summary LSAs from all actively attached areas. This functionality helps to avoid packet loss in some inter-area scenarios.

#### 4.1.1.4 Stub area

A stub area is a designated area that does not allow external route advertisements and cannot contain ASBRs. Virtual links cannot pass through stub areas.

To route to external destinations, the ABR of the stub area advertises a single default route into the stub area (0.0.0.0). A default route is the network route used by a router when no other known route exists for a given IP packet's destination address. All packets for destinations not known by the router's routing table are sent to the default route and out to the network.

This feature reduces the size of the router's database and reduces OSPF protocol traffic, memory usage, and CPU route calculation time.

In [Figure 11: Backbone area](#), areas 0.0.0.1, 0.0.0.2 and 0.0.0.5 could be configured as stub areas.

#### 4.1.1.5 Not-so-stubby area

Another OSPF area type is called a not-so-stubby area (NSSA). NSSAs are similar to stub areas except that limited importing of external routes is allowed. Only routes within the AS are advertised. External routes learned by OSPF routers in the NSSA area are advertised as type 7 LSAs (external route advertisements only within the NSSA area) and are translated by ABRs into type 5 external route advertisements for distribution into other areas of the OSPF domain.

For information about LSA types, see [Link-state advertisements](#).

An NSSA area cannot be designated as the transit area of a virtual link.

In [Figure 11: Backbone area](#), area 0.0.0.3 could be configured as an NSSA area.

### 4.1.2 Virtual links

The backbone area in an OSPF AS must be contiguous and all other areas must be directly connected to the backbone area via an ABR. If it is not practical or possible to physically connect an area to the backbone, virtual links can be used to connect to the backbone through a non-backbone area.

A virtual link functions as a point-to-point link that passes through a transit area. [Figure 11: Backbone area](#) depicts routers Y and Z as the start and end points of the virtual link while area 0.0.0.4 is the transit area. In order to configure virtual links, the router must be an ABR. Virtual links are identified by the router ID of the other endpoint, which is another ABR.

These two endpoint routers must be attached to a common area, called the transit area. The area through which the virtual link passes must have full routing information.

Transit areas pass traffic from an area adjacent to the backbone or to another area. The traffic does not originate or terminate in the transit area. The transit area cannot be a stub area or an NSSA area.

Virtual links are part of the backbone and function as if they were unnumbered point-to-point networks between the two routers. A virtual link uses the intra-area routing of its transit area to forward packets. Virtual links are brought up and down through the building of the shortest-path trees for the transit area.

### 4.1.3 Neighbors and adjacencies

A router uses the OSPF Hello protocol to discover neighbors. Neighbors are routers that interface to a common network. In a broadcast-supported topology, one router sends Hello packets to a multicast address and receives Hello packets in return. Unicast Hello packets are used in non-broadcast topologies.

The neighbors then attempt to form adjacencies by exchanging link-state information with the goal of having identical link-state databases. When the link-state databases of two neighbors are synchronized, they are considered to be adjacent.

#### 4.1.3.1 Designated routers and backup designated routers

In multi-access broadcast networks, such as Ethernet networks, with at least two attached routers, a designated router and a backup designated router can be elected. The concept of a designated router was developed in order to avoid the formation of adjacencies between all attached routers. Without a designated router, the area would be flooded with LSAs – a router would send LSAs to all its adjacent neighbors, and each in turn would send LSAs to all their neighbors, and so on. This would create multiple copies of the same LSA on the same link.

The designated router reduces the number of adjacencies required because each router forms an adjacency only with the designated router and backup designated router. Only the designated router sends LSAs in multicast format to the rest of the network, reducing the amount of routing protocol traffic and the size of the link-state database. If the designated router fails, the backup designated router becomes active.

The designated router is automatically elected based on priority – the router with the highest priority becomes the designated router and the router with the second-highest priority becomes the backup. If two routers have the same priority, the one with the highest router ID wins.

A router with a priority set to 0 can never become a designated router.

After a designated router is elected, it begins sending Hello packets to all other attached routers in order to form adjacencies.

**Note:**

- In point-to-point networks, where a single pair of routers are connected, no designated or backup designated router is elected. An adjacency must be formed with the neighbor router.
- To significantly improve adjacency forming and network convergence, a network should be configured as point-to-point if only two routers are connected, even if the network is a broadcast media such as Ethernet.

### 4.1.4 Link-state advertisements

Link-state advertisements (LSAs) describe the state of a router or network, including router interfaces and adjacency states. Each LSA is flooded throughout an area. The collection of LSAs from all routers and networks form the protocol's link-state (or topological) database.

The distribution of topology database updates takes place along adjacencies. A router sends LSAs to advertise its state according to the configured interval and when the router's state changes. These packets include information about the router's adjacencies, which allows detection of non-operational routes.

When a router discovers a routing table change or detects a change in the network, link-state information is advertised to other routers to maintain identical routing tables. Router adjacencies are reflected in the

contents of its link-state advertisements. The relationship between adjacencies and the link states allow the protocol to detect non-operating routers. Link-state advertisements flood the area. The flooding mechanism ensures that all routers in an area have the same topological database. The database consists of the collection of LSAs received from each router belonging to the area.

OSPF sends only the changed information, not the whole topology information or whole link-state database, when a change takes place. From the topological database, each router constructs a tree of shortest paths with itself as root (that is, runs the Dijkstra algorithm). OSPF distributes routing information between routers belonging to a single AS.

The following table lists the types of LSAs generated by routers.

*Table 33: LSA types*

LSA	Definition
Type 1 - Router	Router link advertisements generated by each internal router for each area it belongs to LSAs are flooded only in the area in which they were originated Router LSAs list all the router's links and the state and cost of the links
Type 2 - Network	Network link advertisements generated by designated routers describing the set of routers attached to a particular network LSAs are flooded only in the area of the router that originated them Network LSAs list all attached routers, including the designated router
Type 3 - Network Summary	Summary link advertisements generated by ABRs describing inter-area routes (areas within the AS but outside the area they are sent into) LSAs let internal routers know which destinations can be reached by the ABR LSAs are sent in both directions – into a non-zero area and into the backbone area
Type 4 - ASBR Summary	Summary link advertisements generated by ABRs indicating the location of ASBRs An ABR generates a type 4 LSA after receiving a type 5 LSA from an ASBR
Type 5 - AS External	Generated by an ASBR and describes destinations external to the AS or a default route external to the AS LSAs are flooded to all areas except stub areas
Type 6 - Group membership	Group membership link entry generated by multicast OSPF routers Not applicable in this release
Type 7 - NSSA External	NSSA external routes generated by an ASBR and used by the NSSA to import external routes into a stub area

LSA	Definition
	<p>LSAs are flooded only to the NSSA</p> <p>The ABR converts type 7 LSAs into type 5 LSAs before flooding them into the backbone, where they are then flooded to all areas except stub areas</p>

### 4.1.5 Metrics

In OSPF, all interfaces have a cost value or routing metric used in the OSPF link-state calculation. A metric value is configured based on hop count, bandwidth, or other parameters, to compare different paths through an AS. OSPF uses cost values to determine the best path to a particular destination – the lower the cost value, the more likely the interface will be used to forward data traffic.

Costs are also associated with externally derived routing data, such as those routes learned from an Exterior Gateway Protocol (EGP), for example, BGP, and are passed transparently throughout the AS. This data is kept separate from the OSPF protocol's link-state data. Each external route can be tagged by the advertising router, enabling the passing of more information between routers on the boundaries of the AS.

### 4.1.6 Authentication

Protocol authentication protects against malicious attacks on the communications between routing protocol neighbors. These attacks could either disrupt communications or inject incorrect routing information into the system's routing table. The use of authentication keys can help to protect routing protocols from these types of attacks.

All OSPF protocol exchanges can be authenticated. This guarantees that only trusted routers can participate in autonomous system routing.

Authentication must be explicitly configured and can be done using two separate mechanisms:

- configuration of an explicit authentication key and algorithm using the **authentication-key** and **authentication-type** commands
- configuration of an authentication keychain using the **auth-keychain** command

Either the **authentication-key** command or the **auth-keychain** command can be used by OSPF, but both cannot be supported at the same time. If both commands are configured, the **auth-keychain** configuration will be applied and the **authentication-key** command will be ignored.

By default, authentication is not enabled on an interface.

#### 4.1.6.1 Authentication key

For explicit authentication keys, OSPF supports plaintext (simple password) and Message Digest 5 (MD5) authentication.

When authentication is enabled on a link, a text string password must be configured. Neighbor OSPF routers must supply the password in all OSPF packets they send to an interface.

Plaintext authentication includes the password in each OSPF packet sent on a link.

MD5 authentication is more secure than plaintext authentication. MD5 authentication uses the password as an encryption key. Routers in the same routing domain must be configured with the same key. When the MD5 hashing algorithm is used for authentication, MD5 is used to verify data integrity by creating a 128-bit message digest from the data input that is included in each packet. The packet is transmitted to the router neighbor and can only be decrypted if the neighbor has the correct password.

The following authentication commands can be configured at the interface level and the virtual link level:

- **authentication-key** – configures the password used by the OSPF interface or virtual link to verify OSPF protocol packets
- **authentication-type** – enables authentication and specifies the type of authentication to be used on the interface or virtual link, either password or message digest
- **message-digest-key** – used when the **message-digest** keyword is selected in the **authentication-type** command

#### 4.1.6.2 Authentication keychains

The keychain mechanism allows for the creation of keys used to authenticate OSPF communications. Each keychain entry defines the authentication attributes to be used in authenticating OSPF messages from remote peers or neighbors; the entry must include at least one key entry to be valid. The keychain mechanism also allows authentication keys to be changed without affecting the state of the OSPF adjacencies and supports stronger authentication algorithms than plaintext and MD5.

Keychains are configured in the **config>system>security>keychain** context. For more information about configuring keychains, see the 7705 SAR System Management Guide, "TCP Enhanced Authentication and Keychain Authentication".

The keychain is then associated with an OSPF interface or virtual link with the **auth-keychain** command.

For a key entry to be valid, it must include a valid key, the current system clock value must be within the begin and end time of the key entry, and the algorithm specified must be supported by OSPF.

OSPF supports the following authentication algorithms:

- clear text password
- MD5
- HMAC-SHA-1-96
- HMAC-SHA-1
- HMAC-SHA-256

Keychain errors are handled as follows:

- If a keychain exists but there are no active key entries with an authentication type that matches the type supported by OSPF, inbound OSPF packets will not be authenticated and will be discarded and no outbound OSPF packets will be sent.
- If a keychain exists but the last key entry has expired, a log entry will be raised indicating that all keychain entries have expired.

OSPF requires that the protocol continue to authenticate inbound and outbound traffic using the last valid authentication key.



### 4.1.7 Route redistribution and summarization

Route redistribution is the taking of routes from one protocol and sending them to another protocol. The 7705 SAR supports the redistribution of static routes into OSPF. These routes are advertised as type 5 or type 7 LSAs (external routes) and are included in each router's link-state database.

Route redistribution involves the use of routing policies. For information about routing policies, see the 7705 SAR Router Configuration Guide, "Route Policies".

Route summarization allows an ABR or ASBR to summarize routes with the same prefix into a single route and distribute it to other areas. Routes redistributed into OSPF from static routes can also be summarized.

Route summarization reduces the amount of routing information across areas and the size of routing tables on the routers, thus improving the calculation speed of the routers.

### 4.1.8 OSPF-TE extensions

OSPF traffic engineering (TE) extensions enable the 7705 SAR to include traffic engineering information in the algorithm in order to calculate the best route to a destination. The traffic information includes:

- maximum reservable bandwidth
- unreserved bandwidth
- available bandwidth

### 4.1.9 Unnumbered interfaces

OSPF supports unnumbered point-to-point interfaces with both Ethernet and PPP encapsulations.

Unnumbered interfaces borrow the address from other interfaces such as system, loopback, or another numbered interface, and use it as the source IP address for packets originated from the interface.

This feature supports both dynamic and static ARP for unnumbered interfaces to allow interworking with unnumbered interfaces that may not support dynamic ARP.

An unnumbered interface has IPv4 capability and is used only in cases where IPv4 is active (IPv4-only and mixed IPv4/IPv6 environments). When configuring an unnumbered interface, the interface specified for the unnumbered interface (system or other) must have an IPv4 address. As well, the interface type for the unnumbered interface will automatically be point-to-point.

The unnumbered option can be used in IES and VPRN access interfaces, as well as in a network interface with MPLS support.

### 4.1.10 IP subnets

OSPF enables the flexible configuration of IP subnets. Each distributed OSPF route has a destination and mask. A network mask is a 32-bit number that indicates the range of IP addresses residing on a single IP network/subnet. This specification displays network masks as hexadecimal numbers; for example, the network mask for a class C IP network is displayed as 0xfffff00. This mask is often displayed as 255.255.255.0.

Two different subnets with the same IP network number might have different masks, called variable-length subnets. A packet is routed to the longest or most specific match. Host routes are considered to be subnets whose masks are all ones (0xffffffff).

For example, for a packet destined for IP address 10.1.1.1, 10.1.1.0/24 is a longer (better) match than 10.1.1.0/16. If both entries are in the routing table, the route designated by 10.1.1.0/24 will be used.

### 4.1.11 OSPF instances

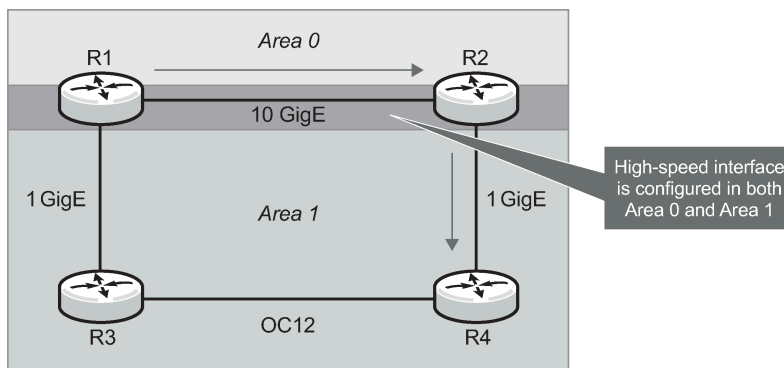
A routing instance is a routing entity for a router. The 7705 SAR supports the default routing instance only; it does not support multiple instances. The default routing instance is associated with the global routing table.

### 4.1.12 Multi-area adjacencies

By default, an IP interface can belong to one OSPF area only. However, there may be situations in which the user wants to configure an interface to belong to more than one area. This configuration allows the corresponding link to be considered an intra-area link in multiple areas and to be preferred over other higher-cost intra-area links.

For example, as shown in the following figure, a high-speed backbone link (in area 0) is established between two ABRs (R1 and R2). The user wants traffic between R1 and R2 in area 1 to use that high-speed link as well. Because intra-area paths are preferred over inter-area paths, by default, R1 will always use the lower-speed links in area 1 to route the traffic. To enable area 1 to use the high-speed link, the user can configure the high-speed interface to belong to both area 0 and area 1.

Figure 14: Multi-area adjacency



28912

The 7705 SAR supports the use of a single IP interface in multiple areas as defined in RFC 5185, *OSPF Multi-Area Adjacency*. With multi-area adjacency, OSPF routers establish multiple adjacencies for different areas over a single logical interface. Each multi-area adjacency is announced as an unnumbered point-to-point link in the configured area by the routers connected to the link. For each area, one logical interface is treated as the primary interface and the other interfaces configured for the area are designated as secondary interfaces.

A logical interface can be configured as the primary interface for one area only. For any other area for which that interface is configured, the interface must be specified as secondary with the command

**config>router>ospf (ospf3)>area>interface** *ip-int-name* **secondary**. It is recommended that area 0 (backbone area) be used for the primary interface association.

Multi-area adjacency is supported for OSPF and OSPFv3. It is also supported under the VPRN context.

### 4.1.13 OSPF import policies

By default, OSPF imports all the routes advertised via LSAs. Import policies allow routes that match a certain criteria, such as neighbor IP addresses, to be rejected. Users must use caution when applying import policies, since not using certain routes may result in network stability issues.

Import policies are supported within the base router context and the VPRN context. Import policies are not supported on OSPFv3.

## 4.2 Bidirectional forwarding detection (BFD) for OSPF

BFD is a simple protocol for detecting failures in a network. BFD uses a "hello" mechanism that sends control messages periodically to the far end and receives periodic control messages from the far end. BFD can detect device, link, and protocol failures.

BFD can be enabled using OSPFv2 (for IPv4) or OSPFv3 (for IPv6). Additionally, a network can be configured to use both OSPFv2 and OSPFv3.

When BFD is enabled on an OSPF interface, the state of the interface is tied to the state of the BFD session between the local node and remote (far-end) node. BFD is implemented in asynchronous mode only, meaning that neither end responds to control messages; rather, the messages are sent in the time period configured at each end.

If the configured number of consecutive BFD missed messages is reached, the link is declared down and OSPF takes the appropriate action (for example, generates an LSA update against the failed link or reroutes around the failed link).

Due to the lightweight nature of BFD, it can detect failures faster than other detection protocols, making it ideal for use in applications such as mobile transport.

## 4.3 Graceful restart helper

Graceful restart and non-stop routing (NSR) both provide mechanisms that allow neighbor routers to handle a service interruption due to a CSM switchover. Data packets continue to be forwarded along known routes while the OSPF information is being restored or refreshed following the switchover.

With graceful restart, a router undergoing a switchover informs its adjacent neighbors and requests a grace period whereby traffic is still forwarded based on the last known good FIB while the router restarts. The neighbor must cooperate with the requesting router in order for the traffic to be forwarded. After the switchover, the neighbor relationships must be re-established.

With NSR (or high-availability service), routing neighbors are unaware of any event on the router performing a switchover. All activity switches to the inactive CSM, which maintains up-to-date routing information, so that routing topology and reachability are not affected. NSR is a more reliable and robust way of handling service interruptions than graceful restart.

The 7705 SAR supports NSR; therefore, graceful restart is not implemented on the router. However, to support neighbor routers that do not have high-availability service, the 7705 SAR supports graceful restart helper. In graceful restart helper mode, the 7705 SAR never requests graceful restart support. However, if a grace LSA is received from an OSPF neighbor, the 7705 SAR keeps the link toward that neighbor up and operational until the specified grace period in the grace LSA expires or the graceful restart is successful, whichever comes first.

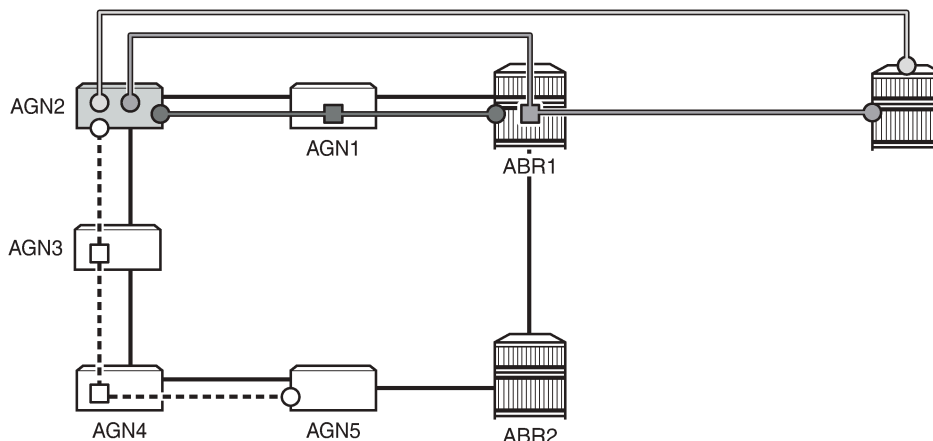
## 4.4 LFA protection using segment routing backup node SID

One of the challenges in MPLS deployments across multiple IGP areas or domains, such as in seamless MPLS design, is the provisioning of FRR local protection in access and metro domains that make use of a ring, a square, or a partial mesh topology. In order to implement IP, LDP, or SR FRR in these topologies, the remote LFA feature must be implemented. Remote LFA provides a Segment Routing (SR) tunneled LFA next hop for an IP prefix, an LDP tunnel, or an SR tunnel. For prefixes outside of the area or domain, the access or aggregation router must push four labels: service label, BGP label for the destination PE, LDP/RSVP/SR label to reach the exit ABR/ASBR, and one label for the remote LFA next hop. Small routers deployed in these parts of the network have limited MPLS label stack size support.

The following figure illustrates the label stack required for the primary next-hop and the remote LFA next hop computed by aggregation node AGN2 for the inter-area prefix of a remote PE. For an inter-area BGP labeled unicast route prefix for which ABR1 is the primary exit ABR, AGN2 resolves the prefix to the transport tunnel of ABR1 and therefore, uses the remote LFA next hop of ABR1 for protection. The primary next hop uses two transport labels plus a service label. The remote LFA next hop for ABR1 uses PQ node AGN5 and pushes three transport labels plus a service label.

Seamless MPLS with fast restoration requires up to four labels to be pushed by AGN2, as shown in the figure.

Figure 15: Label stack for remote LFA in ring topology



Path	Label Location	Label Name	Assigned By	Protocol	Use
====	Label 1 (Bottom)	Service (PW, VC) Label	Remote PE	MP-BGP, T-LDP	Identifies Service on Remote PE
====	Label 2	Inter-Area Label	ABR1	BGP-LU	Identifies Path to Remote PE
====	Label 3	Intra-Area	AGN1	LDP, RSVP, SR	Identifies Path to ABR1
----	Label 4 (Top)	R-LFA Label	AGN3	LDP, RSVP, SR	Identifies Path to AGN5

**Legend:**

- Endpoint
- Transit point

27865

The objective of LFA protection with a backup node segment ID (SID) is to reduce the label stack pushed by AGN2 for BGP labeled unicast inter-area prefixes. When link AGN2-AGN1 fails, packets are directed away from the failure and forwarded toward ABR2, which acts as the backup for ABR1 (and vice versa when ABR2 is the primary exit ABR for the BGP labeled unicast inter-area prefix). This requires that ABR2 advertise a special label for the loopback of ABR1 that will attract packets normally destined for ABR1. These packets will be forwarded by ABR2 to ABR1 via the inter-ABR link.

As a result, AGN2 will push the label advertised by ABR2 to back up ABR1 on top of the BGP label for the remote PE and the service label. This keeps the label stack the same size for the LFA next hop to be the same size as that of the primary next-hop. It is also the same size as the remote LFA next hop for the local prefix within the ring.

### 4.4.1 Configuring LFA using backup node SID

LFA using a backup node SID is enabled by configuring a backup node SID at an ABR/ASBR that acts as a backup to the primary exit ABR/ASBR of inter-area/inter-as routes learned as BGP labeled routes.

**CLI syntax:**

```
config>router>ospf>segment-routing$
  backup-node-sid ip-prefix/prefix-length index 0..4294967295
  backup-node-sid ip-prefix/prefix-length label 1..4294967295
```

The user can enter either a label or an index for the backup node SID.



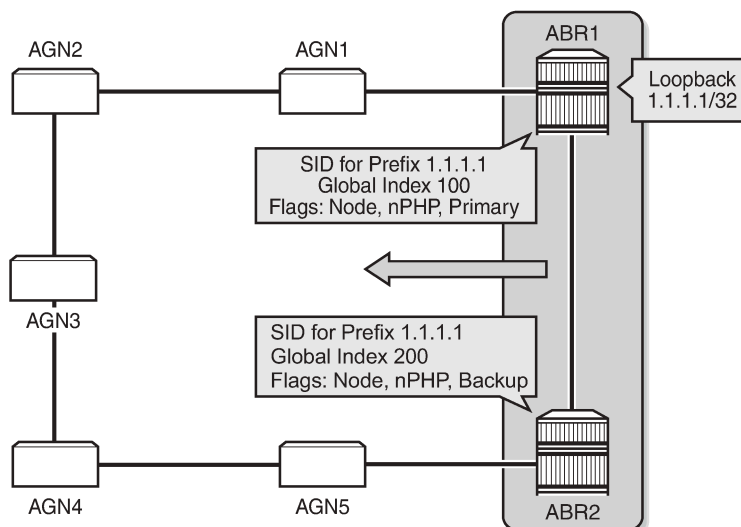
**Note:** This feature only allows the configuration of a single backup node SID per IGP instance and per ABR/ASBR. In other words, only a pair of ABR/ASBR nodes can back up each other in an IGP domain. Each time the user invokes the above command within the same IGP instance, it overrides any previous configuration of the backup node SID. The same ABR/ASBR can, however, participate in multiple IGP instances and provide backup support within each instance.

#### 4.4.2 Detailed operation of LFA protection using backup node SID

As shown in the following figure, LFA for seamless MPLS supports environments where the boundary routers are either:

- ABR nodes that connect with IBGP multiple domains, each using a different area of the same IGP instance
- ASBR nodes that connect domains running different IGP instances and use IBGP within a domain and EBGP to the other domains

Figure 16: Backup ABR node SID



27866

The following steps describe the configuration and behavior of LFA protection using backup node SID:

1. The user configures node SID 100 in ABR1 for its loopback prefix 1.1.1.1/32. This is the regular node SID. ABR1 advertises the prefix SID sub-TLV for this node SID in the IGP and installs the ILM using a unique label.
2. Each router receiving the prefix sub-TLV for node SID 100 resolves it as described in [Segment routing in shortest path forwarding](#). Changes to the programming of the backup NHLFE of node SID 100 based on receiving the backup node SID for prefix 1.1.1.1/32 are defined in [Duplicate SID handling](#).
3. The user configures a backup node SID 200 in ABR2 for the loopback 1.1.1.1/32 of ABR1. The SID value must be different from that assigned by ABR1 for the same prefix. ABR2 installs the ILM, which performs a swap operation from the label of SID 200 to that of SID 100. The ILM must point to a direct link and next hop to reach 1.1.1.1/32 of ABR1 as its primary next hop. The IGP examines all adjacencies established in the same area as that of prefix 1.1.1.1/32 and determines which ones have ABR1 as a direct neighbor and with the best cost. If more than one adjacency has the best cost,

the IGP selects the one with the lowest interface index. If there is no adjacency to reach ABR2, the prefix SID for the backup node is flushed and is not resolved. This is to prevent any other non-direct path being used to reach ABR1. As a result, any received traffic on the ILM of SID 200 traffic will be blackholed.

4. If resolved, ABR2 advertises the prefix SID sub-TLV for this backup node SID 200 and indicates in the SR Algorithm field that a modified SPF algorithm, referred to as "Backup-constrained-SPF", is required to resolve this node SID.

5. Each router receiving the prefix sub-TLV for the backup node SID 200 performs the following steps.

The following resolution steps do not require a CLI command to be enabled.

- a. The router determines which router is being backed up. This is achieved by checking the router ID owner of the prefix sub-TLV that was advertised with the same prefix but without the backup flag and which is used as the best route for the prefix. In this case, it should be ABR1. Then the router runs a modified SPF by removing node ABR1 from the topology to resolve the backup node SID 200. The primary next hop should point to the path to ABR2 in the counter clockwise direction of the ring.

The router will not compute an LFA or a remote LFA for node SID 200 because the main SPF used a modified topology.

- b. The router installs the ILM and primary NHLFE for the backup node SID.

Only a swap label operation is configured by all routers for the backup node SID. There is no push operation, and no tunnel for the backup node SID is added into the TTM.

- c. The router programs the backup node SID as the LFA backup for the SR tunnel to node SID of 1.1.1.1/32 of ABR1. In other words, each router overrides the remote LFA backup for prefix 1.1.1.1/32, which is normally PQ node AGN5.

- d. If the router is adjacent to ABR1, for example AGN1, it also programs the backup node SID as the LFA backup for the protection of any adjacency SID to ABR1.

6. When node AGN2 resolves a BGP label route for an inter-area prefix for which the primary ABR exit router is ABR1, it will use the backup node SID of ABR1 as the remote LFA backup instead of the SID to the PQ node (AGN5 in this example) to save on the pushed label stack.

AGN2 continues to resolve the prefix SID for any remote PE prefix that is summarized into the local area of AGN2 as usual. AGN2 programs a primary next hop and a remote LFA next hop. Remote LFA will use AGN5 as the PQ node and will push two labels, as it would for an intra-area prefix SID. There is no need to use the backup node SID for this prefix SID and force its backup path to go to ABR1. The backup path may exit from ABR2 if the cost from ABR2 to the destination prefix is shorter.

7. If the user excludes a link from LFA in the IGP instance (**config>router>ospf>area>interface>loopfree-alternate-exclude** or **config>router>isis>interface>loopfree-alternate-exclude**), a backup node SID that resolves to that interface will not be used as a remote LFA backup in the same way as regular LFA or PQ remote LFA next-hop behavior.
8. If the OSPF neighbor of a router is put into overload or if the metric of an OSPF interface to that neighbor is set to LSInfinity (0xFFFF), a backup node SID that resolves to that neighbor will not be used as a remote LFA backup in the same way as regular LFA or PQ remote LFA next hop behavior.
9. If the IS-IS neighbor of a router is put into overload or if the metric of an IS-IS interface to that neighbor is set to overload max-metric (0xffffe), a backup node SID that resolves to that neighbor will be used as a remote LFA backup in the same way as regular LFA or PQ remote LFA next hop behavior.



**Note:** Other routers in the network will not forward transit traffic to the router in overload.

- 10. If the IS-IS interface to a neighbor is set to maximum link metric (0xfffff), a backup node SID that resolves to that neighbor will not be used as a remote LFA backup in the same way as regular LFA or PQ remote LFA next hop behavior.
- 11. LFA policy is supported for IP next hops only. It is not supported with tunnel next hops such as IGP shortcuts or remote LFA tunnels. A backup node SID is also a tunnel next hop and therefore a user-configured LFA policy will not be applied to check constraints such as admin-groups and SRLG against the outgoing interface of the selected backup node SID.

### 4.4.3 Duplicate SID handling

When the IGP issues or receives an LSA/LSP containing a prefix SID sub-TLV for a node SID or a backup node SID with a SID value that is a duplicate of an existing SID or backup node SID, the resolution in the following table is followed.

Table 34: Handling of duplicate SIDs

Old LSA/LSP	New LSA/LSP			
	Backup node SID	Local backup node SID	Node SID	Local node SID
Backup Node SID	Old	New	New	New
Local Backup Node SID	Old	Equal	New	New
Node SID	Old	Old	Equal/Old <sup>1</sup>	Equal/New <sup>2</sup>
Local Node SID	Old	Old	Equal/Old <sup>1</sup>	Equal/Old <sup>1</sup>

**Notes:**

1. Equal/Old means the following:
  - If the prefix is duplicate, it is equal and no change is needed. Keep the old LSA/LSP.
  - If the prefix is not duplicate, still keep the old LSA/LSP.
2. Equal/New means the following:
  - If the prefix is duplicate, it is equal and no change is needed. Keep the old LSA/LSP.
  - If the prefix is not duplicate, pick a new prefix and use the new LSA/LSP.

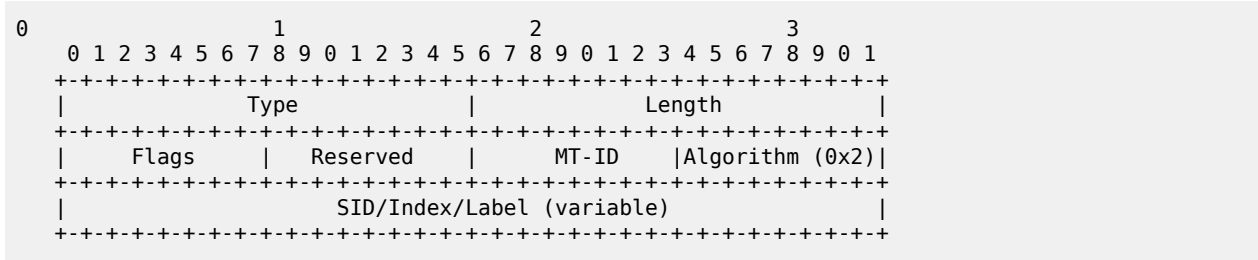
### 4.4.4 OSPF control plane extensions

All routers supporting OSPF control plane extensions must advertise support of the new algorithm "Backup-constrained-SPF" of value 2 in the SR-Algorithm TLV, which is advertised in the Router Information Opaque LSA. This is in addition to the default supported algorithm "IGP-metric-based-SPF" of



value 0. The following shows the encoding of the prefix SID sub-TLV to indicate a node SID of type backup and to indicate the modified SPF algorithm in the SR Algorithm field. The values used in the Flags field and in the Algorithm field are SR OS proprietary.

The new Algorithm (0x2) field and values are used by this feature.

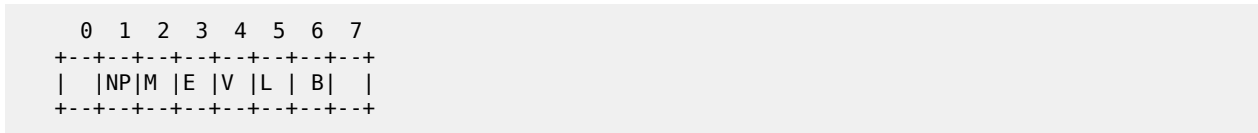


The following table lists OSPF control plane extension field values.

Table 35: OSPF control plane extension fields

Field	Value
Type	2
Length	variable
Flags	1 octet field

The following flags are defined; the "B" flag is new:



The following table lists OSPF control plane extension flag values.

Table 36: OSPF control plane extension flags

Flag	Description
NP-Flag	No-PHP flag If set, the penultimate hop must not pop the prefix SID before delivering the packet to the node that advertised the prefix SID
M-Flag	Mapping Server Flag If set, the SID is advertised from the Segment Routing Mapping Server functionality as described in I-D.filsfils-spring-segment-routing-ldp-interop
E-Flag	Explicit-Null Flag If set, any upstream neighbor of the prefix SID originator must replace the prefix SID with a prefix SID having an Explicit-NULL value (0 for IPv4) before forwarding the packet.

Flag	Description
V-Flag	Value/Index Flag If set, the prefix SID carries an absolute value. If not set, the prefix SID carries an index.
L-Flag	Local/Global Flag If set, the value/index carried by the prefix SID has local significance. If not set, the value/index carried by this sub-TLV has global significance.
B-Flag	This flag is used by the Protection using backup node SID feature. If set, the SID is a backup SID for the prefix. This value is SR OS proprietary.
Other bits	Reserved These must be zero when sent and are ignored when received.
MT-ID	Multi-Topology ID, as defined in RFC 4915
Algorithm	One octet identifying the algorithm the prefix SID is associated with. A value of (0x2) indicates the modified SPF algorithm, which removes from the topology the node that is backed up by the backup node SID. This value is SR OS proprietary.
SID/Index/Label	Based on the V and L flags, it contains either: <ul style="list-style-type: none"> <li>a 32-bit index defining the offset in the SID/Label space advertised by this router</li> <li>a 24-bit label where the 20 rightmost bits are used for encoding the label value</li> </ul>

#### 4.4.5 Topology-independent LFA for OSPF

OSPFv2 supports topology-independent LFA (TI-LFA), which improves the protection coverage of a network topology by computing and automatically instantiating a repair tunnel to a Q node that is not in the shortest path from the computing node. The 7705 SAR supports TI-LFA for both link protection and node protection. See [Topology-independent LFA](#) and [Node protection support in remote LFA and TI-LFA](#) for more information. The information in these sections refers to IS-IS but also applies to OSPF.

### 4.5 LDP and IP fast reroute (FRR) for OSPF prefixes

LDP fast reroute (FRR) provides local protection for an LDP FEC by precalculating and downloading a primary and a backup NHLFE for the FEC to the LDP FIB. The primary NHLFE corresponds to the label of the FEC received from the primary next hop as per the standard LDP resolution of the FEC prefix in the RTM. The backup NHLFE corresponds to the label received for the same FEC from a loop-free alternate (LFA) next hop.

LDP FRR improves convergence in case of a local link or node failure in the network, by using the label-FEC binding received from the LFA next hop to forward traffic for a given prefix as soon as the primary

next hop is not available. This means that a router resumes forwarding LDP packets to a destination prefix using the backup path without waiting for the routing convergence.

IP fast reroute (FRR) protects against link or node failures in an IP network by precalculating a backup route to use when the primary next hop is not available. Both routes are populated in the RTM. IP FRR uses an LFA backup next hop to forward in-transit IP packets as soon as the primary next hop failure is detected and the backup is invoked. This means that a node resumes forwarding IP packets to a destination prefix without waiting for the routing convergence.

See RFC 5286, *Basic Specification for IP Fast Reroute: Loop-Free Alternates*, for more information about LFAs.

See the 7705 SAR MPLS Guide "LDP Fast Reroute (FRR)" for more information about LDP FRR and the 7705 SAR Router Configuration Guide, "IP Fast Reroute (FRR)" for more information about IP FRR.

LFAs are supported on IPv4 and IPv6 OSPF prefixes, VPN IPv4 OSPF prefixes, and on inter-area OSPF prefixes. LFAs are also supported on IPv4 IS-IS prefixes and on inter-level IS-IS prefixes. For information about LFA support for IS-IS prefixes, see [LDP and IP fast reroute \(FRR\) for IS-IS prefixes](#).

IP FRR also provides an LFA backup next hop for the destination prefix of a GRE tunnel used in an SDP or in VPRN autobind.

#### 4.5.1 LFA calculations

In addition to performing the shortest path first (SPF) calculation of the primary next hop, OSPF must calculate a backup next hop for all prefixes used by LDP to resolve FECs and for all prefixes used by IP to forward packets. The backup next hops are calculated to provide single link or node protection and to guarantee that when a failure occurs, forwarding traffic through the backup next hop will not result in a loop. These backup next hops are called Loop-Free Alternates (LFAs).

The 7705 SAR supports remote LFA for both link protection and node protection. For detailed information about the remote LFA algorithm, see [Remote LFA with segment routing](#).

In general, in order to calculate LFAs for a specific destination (D), a router must know the following information:

- the shortest-path distance from the calculating router (source) to the destination (SP(S,D))
- the shortest-path distance from the router's OSPF neighbors to the destination (SP(N,D))
- the shortest-path distance from the router's OSPF neighbors to itself (SP(N,S))

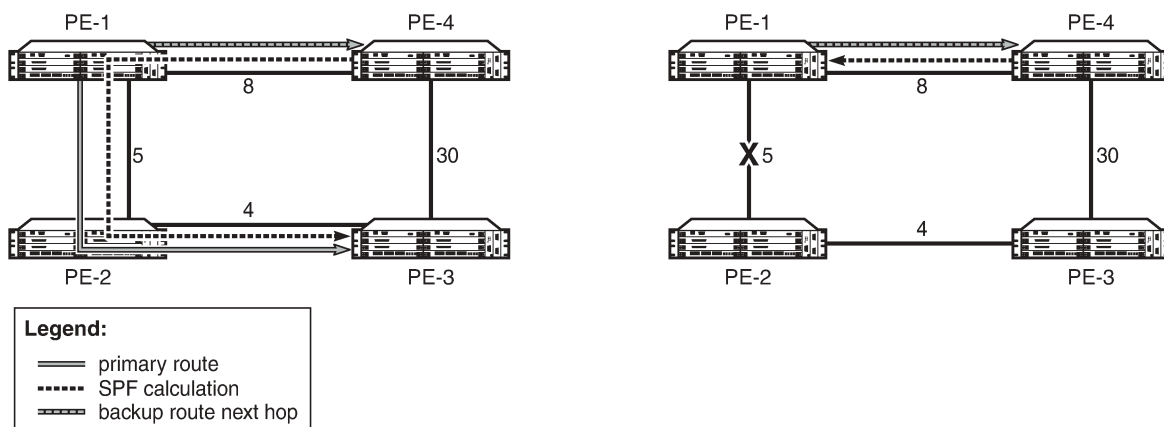
A neighbor (N) can provide an LFA only if:

$$SP(N,D) < SP(N,S) + SP(S,D)$$

This is known as loop-free criterion.

The following figure shows an example of a backup route resulting in a microloop. In the example, PE-1 uses PE-2 as its next hop to reach PE-3. The total cost to reach PE-3 via PE-2 is 9. If the link between PE-1 and PE-2 fails, PE-1 can try to use PE-4 as its next hop to reach PE-3. However, the metric between PE-4 and PE-3 is 30. From the perspective of PE-4, forwarding traffic via the PE-1 and PE-2 path to PE-3 is more viable, as the cost is 17 (8 + 5 + 4) versus the direct link cost of 30. Therefore, if PE-1 forwards the traffic to PE-4 in order to reach PE-3, PE-4 forwards it back to PE-1, creating a microloop, until the routing protocols converge and declare the link between PE-1 and PE-2 to be down. PE-4 would then be forced to take the direct PE-3 link to reach PE-3 as there is no other alternative. Because PE-4 does not meet the loop-free criterion, it cannot be used as a valid LFA.

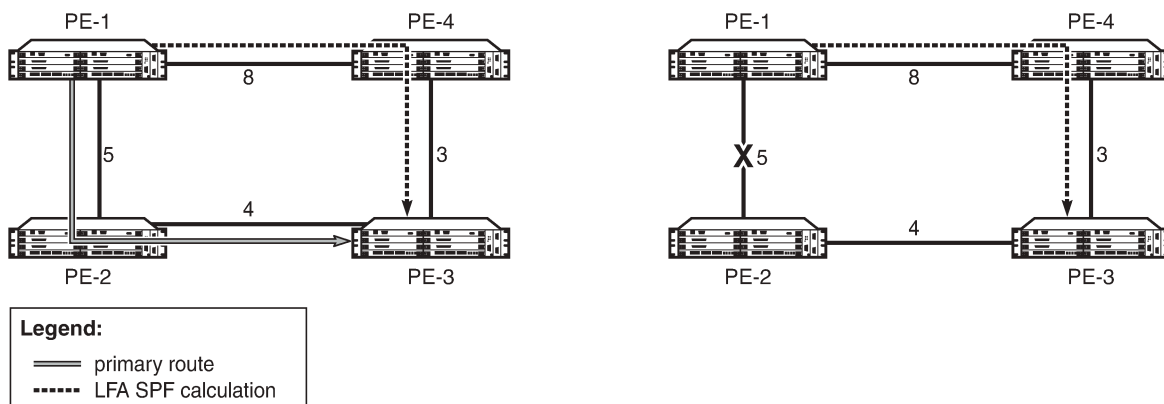
Figure 17: Backup routes resulting in microloops



25313

The following figure shows an example of an LFA backup route. In this example, PE-1 again uses PE-2 as its next hop to reach PE-3. The total cost to reach PE-3 via PE-2 is 9. If the link between PE-1 and PE-2 fails, PE-1 can use PE-4 to reach PE-3. From the perspective of PE-4, the direct route to PE-3 is a viable route, as the cost is 3 versus the cost of forwarding traffic via PE-1 (17). Using the direct route does not cause microloops and meets the loop-free criterion; therefore, PE-4 can be used as a valid LFA.

Figure 18: LFA backup route



25314

### 4.5.1.1 Selection algorithm

For a point-to-point interface, if SPF finds multiple LFA next hops for a given primary next hop, the selection algorithm is as follows:

1. SPF will pick the node-protect type over the link-protect type.
2. If there is more than one LFA next hop within the selected type, it will pick one based on the least cost.
3. If there is more than one LFA next hop with the same cost, SPF will select the first one. This is not a deterministic selection and will vary for each SPF calculation.

For a broadcast interface, a node-protect LFA is not necessarily a link-protect LFA if the path to the LFA next hop goes over the same pseudonode as the primary next hop. Similarly, a link-protect LFA may not guarantee link protection if it goes over the same pseudonode as the primary next hop.

When SPF finds multiple LFA next hops for a given primary next hop, the selection algorithm is as follows:

1. The algorithm splits the LFA next hops into two sets:
  - the first set consists of LFA next hops that do not go over the pseudonode used by the primary next hop
  - the second set consists of LFA next hops that do go over the pseudonode used by the primary next hop
2. If there is more than one LFA next hop in the first set, it will pick the node-protect type over the link-protect type.
3. If there is more than one LFA next hop within the selected type, it will pick one based on the least cost.
4. If there is more than one LFA next hop with the same cost, SPF will select the first one from the remaining set. This is not a deterministic selection and will vary for each SPF calculation.
5. If no LFA next hop results from step 4, SPF will rerun steps 2 to 4 using the second set.



**Note:** A node-protect LFA that does not guarantee link protection can still be selected as a last resort; as well, a link-protect LFA that does not guarantee node protection can still be selected as a last resort.

Both the calculated primary next hop and LFA next hop for a given prefix are programmed into the RTM.

### 4.5.1.2 LFA configuration

To enable LFA for OSPF prefixes, use the following command:

```
config>router>ospf>loopfree-alternates
```

or

```
config>router>ospf3>loopfree-alternates
```

Next, enable FRR for LDP and/or IP by entering the following commands:

```
config>router>ldp>fast-reroute
```

```
config>router>ip-fast-reroute
```

These commands instruct the OSPF SPF algorithm to precalculate a primary next hop and LFA next hop for every learned prefix, in order to provide FRR to LDP FEC packets and/or IP packets.

To exclude all interfaces within a specific OSPF area or to exclude a specific IP interface from being included in the LFA SPF calculation, enter the following commands:

```
config>router>ospf>area>loopfree-alternate-exclude
```

or

```
config>router>ospf3>area>loopfree-alternate-exclude
```

```
config>router>ospf>area>interface>loopfree-alternate-exclude
```

or

```
config>router>ospf3>area>interface>loopfree-alternate-exclude
```

If IGP shortcuts are also enabled, any LSPs with a destination address in that OSPF area are not included in the LFA SPF calculation.

If an interface is excluded from the LFA SPF, it is excluded in all areas. However, the **loopfree-alternate-exclude** command can only be executed under the area in which the specified interface is primary. When the command is executed, the interface is excluded in that area and in all other areas where the interface is secondary. If the user attempts to execute the command under an area where the interface is secondary, the command will fail.



**Note:** The **loopfree-alternates** and **loopfree-alternate-exclude** commands are also supported for OSPF and OSPFv3 within a VPRN service.

## 4.5.2 IGP shortcuts (RSVP-TE tunnels)

Microloops, especially in ring topologies, are typically unavoidable. As the number of nodes in a ring increases, the chance of microloops occurring also increases. In cases where a valid directly connected next hop cannot be ensured, remote LFAs can be used. Remote LFAs are non-directly connected LFA next hops that are reached via IGP shortcuts.

IGP shortcuts are an MPLS functionality where LSPs are treated like physical links within IGPs; that is, LSPs can be used for next hop reachability. If an RSVP-TE LSP is used as a shortcut by OSPF or IS-IS, it is included in the SPF calculation as a point-to-point link for both primary and LFA next hops. It can also be advertised to neighbors so that the neighboring nodes can also use the links to reach a destination via the advertised next hop.

IGP shortcuts can be used to simplify remote LFA support and simplify the number of LSPs required in a ring topology.

IGP shortcut functionality provides two options:

- **LFA-protect** option

This option allows an LSP to be included in both the main SPF and the loop-free alternate (LFA) SPF algorithm. For a specific prefix, the LSP can be used either as a primary next hop or as an LFA next hop, but not both.

If the main SPF calculation selects a tunneled primary next hop for a prefix, the LFA SPF calculation will not select an LFA next hop for this prefix and the protection of this prefix will rely on the RSVP LSP FRR protection.

If the main SPF calculation selects a direct primary next hop, the LFA SPF calculation will select an LFA next hop for this prefix but will prefer a direct LFA next hop over a tunneled LFA next hop.

- **LFA-only** option

This option allows an LSP to be included in the LFA SPF algorithm only, which means that the introduction of IGP shortcuts does not affect the main SPF decision. For a specific prefix, the main SPF calculation always selects a direct primary next hop. The LFA SPF calculation will select an LFA next hop for this prefix but will prefer a direct LFA next hop over a tunneled LFA next hop.

### 4.5.2.1 Selection algorithm

If there are multiple LFA next hops for a primary next hop, the selection algorithm is as follows:

1. The algorithm splits the LFA next hops into two sets:
  - the first set consists of direct LFA next hops

- the second set consists of tunneled LFA next hops after excluding the LSPs that use the same outgoing interface as the primary next hop
2. The algorithm continues with the first set if it is not empty; otherwise, it continues with the second set.
  3. If the second set is used, the algorithm selects the tunneled LFA next hop whose endpoint corresponds to the node advertising the prefix:
    - if more than one tunneled next hop exists, it selects the one with the lowest LSP metric
    - if more than one tunneled next hop still exists, it selects the one with the lowest tunnel ID
    - if none is available, it continues with rest of the tunneled LFAs in the second set
  4. Within the selected set, the algorithm splits the LFA next hops into two sets:
    - the first set consists of LFA next hops that do not go over the pseudonode used by the primary next hop
    - the second set consists of LFA next hops that go over the pseudonode used by the primary next hop
  5. If there is more than one LFA next hop in the selected set, it will pick the node-protect type over the link-protect type.
  6. If there is more than one LFA next hop within the selected type, it will pick one based on the least total cost for the prefix. For a tunneled next hop, that means the LSP metric plus the cost of the LSP endpoint to the destination of the prefix.
  7. If there is more than one LFA next hop within the selected type in the first set (ECMP is configured), it will select the first direct next hop from the remaining set. This is not a deterministic selection and will vary for each SPF calculation.
  8. If there is more than one LFA next hop within the selected type in the second set (ECMP is configured), it will pick the tunneled next hop with the lowest cost from the endpoint of the LSP to the destination prefix. If there remains more than one next hop, it will pick the tunneled next hop with the lowest tunnel ID.

### 4.5.2.2 Forwarding adjacency

The forwarding adjacency feature allows OSPF to advertise an RSVP-TE LSP as a link so that other routers in the network can include it in the SPF calculations. The RSVP-TE is advertised as an unnumbered point-to-point link and the link-state advertisement (LSA) has no traffic engineering opaque sub-TLVs as per RFC 3906, *Calculating Interior Gateway Protocol (IGP) Routes Over Traffic Engineering Tunnels*.

The forwarding adjacency feature can be enabled independently from the IGP shortcut feature. If both features are enabled for OSPF, forwarding adjacency takes precedence.

When forwarding adjacency is enabled, each node advertises a point-to-point unnumbered link for each best-metric tunnel to the router ID of any endpoint node. The node does not include the tunnels as IGP shortcuts in the SPF calculation directly. Instead, when the LSA advertising the corresponding point-to-point unnumbered link is installed in the local routing database, the node performs an SPF calculation using the link like any other link LSA. The link bidirectional check requires that a regular link or tunnel link exist in the reverse direction for the tunnel to be used in SPF calculations.

### 4.5.2.3 IGP shortcut configuration

To enable the use of IGP shortcuts by OSPF, enter the following command:

```
config>router>ospf>rsvp-shortcut
```

To enable forwarding adjacency in OSPF, enter the following command:

```
config>router>ospf>advertise-tunnel-link
```

To enable the use of an RSVP-TE LSP by OSPF as a shortcut or as a forwarding adjacency for resolving IGP routes, enter the following command:

```
config>router>mpls>lsp>igp-shortcut
```

When the **rsvp-shortcut** or **advertise-tunnel-link** option is enabled in OSPF, all RSVP-TE LSPs originating on this node are eligible by default as long as the destination address of the LSP, as configured with the **config>router> mpls>lsp>to** command, corresponds to a router ID of a remote node. A specific LSP can be excluded from being used as a shortcut or forwarding adjacency with the **no** form of the **igp-shortcut** command.

### 4.5.3 LFA SPF policies

An LFA SPF policy allows the user to apply specific criteria to the selection of a LFA backup next hop for a subset of prefixes that resolve to a specific primary next hop. The 7705 SAR supports the following LFA SPF policy constraints:

- admin group
- shared risk link group (SRLG)
- protection type
- next hop type

A route next hop policy template must first be created under the global router context. The template contains criteria for the policies in the preceding list.

The template is then applied to prefixes protected by LFA. Each instance of OSPF can apply the same policy template to one or more prefixes and interfaces. If a template is modified, OSPF re-evaluates it for any changes and, if necessary, schedules a new LFA SPF to recalculate the LFA next hop for any prefixes associated with the template.

As a related feature, prefixes that match a prefix entry in a prefix policy can be excluded from the LFA SPF calculation. If a prefix is excluded, it is not included in the LFA SPF calculation, regardless of its priority. Prefix policies are created with the **config>router>policy-options>prefix-list** command (for information about prefix lists, see the 7705 SAR Router Configuration Guide, "Route Policies").

#### 4.5.3.1 LFA SPF policy configuration

To create a route next hop policy template, enter the following command:

```
config>router>route-next-hop-policy template
```

Configure the template with policy constraints for the items in the preceding list.





**Note:** To configure constraints for admin groups and SRLG groups, these groups must already be created in the **config>router>if-attribute>admin-group** and **config>router>if-attribute>srlg-group** contexts.

Next, apply the template to OSPF interfaces by entering the following command:

```
config>router>ospf>area>interface>lfa-policy-map>route-nh-template
```

or

```
config>router>ospf3>area>interface>lfa-policy-map>route-nh-template
```

The template is applied to all prefixes using the specified interface name.

When a route next hop policy template is applied to an interface, it is applied in all areas. However, the **route-nh-template** command can only be executed under the area in which the specified interface is primary. When the command is executed, the template is applied in that area and in all other areas where the interface is secondary. If the user attempts to execute the command under an area where the interface is secondary, the command will fail.

Optionally, exclude prefixes in a prefix policy from the LFA SPF calculation by entering the following command:

```
config>router>ospf>loopfree-alternates>exclude>prefix-policy
```

or

```
config>router>ospf3>loopfree-alternates>exclude>prefix-policy
```



**Note:** The **lfa-policy-map** and **loopfree-alternate-exclude** commands are also supported for OSPF within a VPRN service.

## 4.6 Preconfiguration requirements

The router ID must be available before OSPF can be configured. The router ID is a 32-bit IP address assigned to each router running OSPF. This number uniquely identifies the router within an AS. OSPF routers use the router IDs of the neighbor routers to establish adjacencies. Neighbor IDs are learned when Hello packets are received from the neighbor.

Before configuring OSPF parameters, ensure that the router ID is derived by one of the following methods:

- define the value using the **config>router>router-id** *ip-address* command
- define the system interface using the **config>router>interface** *ip-int-name* command (used if the router ID is not specified with the **config>router>router-id** *ip-address* command)

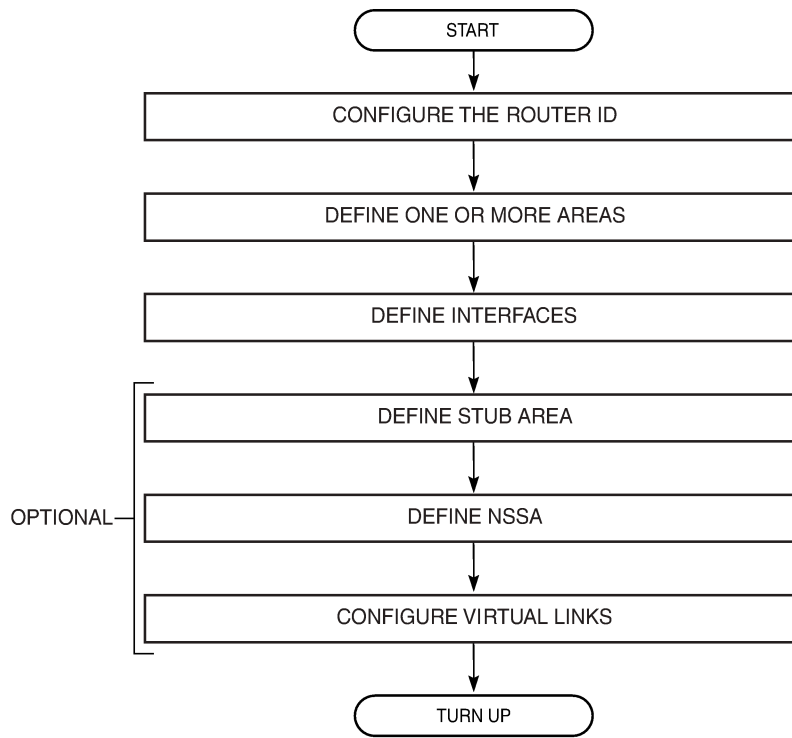
A system interface must have an IP address with a 32-bit subnet mask. The system interface is assigned during the primary router configuration process when the interface is created in the logical IP interface context.

- if you do not specify a router ID, the last 4 bytes of the MAC address are used

## 4.7 OSPF configuration process overview

The following figure displays the process to provision basic OSPF parameters.

Figure 19: OSPF configuration process



21825

## 4.8 Configuration notes

- Before OSPF can be configured, the router ID must be configured.
- The basic OSPF configuration includes at least one area and an associated interface.
- All default and command parameters can be modified.
- By default, a router has no configured areas.
- The base OSPF instance is created in the administratively enabled state.

## 4.9 Configuring OSPF with CLI

This section provides information to configure the OSPF protocol using the command line interface.

Topics in this section include:

- [OSPF configuration guidelines](#)
- [Basic OSPF configuration](#)
- [Configuring other OSPF components](#)
- [OSPF configuration management tasks](#)

## 4.10 OSPF configuration guidelines

Configuration planning is essential to organize routers, backbone, non-backbone, stub, NSSA areas, and transit links. OSPF provides essential defaults for basic protocol operability. You can configure or modify most commands and parameters.

The minimal OSPF parameters that are necessary to deploy OSPF are:

- router ID

Each router running OSPF must be configured with a unique router ID. The router ID is used by the OSPF routing protocol to establish adjacencies.

If a new router ID is defined, the OSPF protocol is not automatically restarted with the new ID. The router must be shut down and restarted in order to initialize the new router ID.

- area

At least one OSPF area must be created. An interface must be assigned to each OSPF area.

- interfaces

An interface is the connection between a router and one of its attached networks. An interface has state information associated with it, which is obtained from the underlying lower-level protocols and the routing protocol. An interface to a network has associated with it a single IP address and mask (unless the network is an unnumbered point-to-point network). An interface is sometimes also referred to as a link.

All configuration applies to both OSPF and OSPFv3 unless specifically noted in the [OSPF command reference](#).

## 4.11 Basic OSPF configuration

This section provides information to configure OSPF as well as configuration examples of common configuration tasks.

The minimal OSPF parameters that need to be configured are:

- a router ID
- one or more areas
- interfaces (**interface "system"**)

The following is an example of a basic OSPF configuration:

```
ALU-A>config>router>ospf# info
-----
    area 0.0.0.0
      interface "system"
      exit
    exit
  area 0.0.0.20
    nssa
    exit
    interface "to-104"
      priority 10
    exit
  exit
```

```

        area 0.0.1.1
        exit
-----
ALU-A>config>router>ospf#

```

### 4.11.1 Configuring the router ID

The router ID uniquely identifies the router within an AS. In OSPF, routing information is exchanged between autonomous systems, which are groups of networks that share routing information. The router ID can be set to be the same as the system interface address (loopback address). This is the default setting.

The router ID is derived by one of the following methods:

- defining the value using the **config>router>router-id** *ip-address* command
- defining the system interface using the **config>router>interface** *ip-int-name* command (used if the router ID is not specified with the **config>router>router-id** *ip-address* command)
- inheriting the last 4 bytes of the MAC address

When configuring a new router ID, protocols are not automatically restarted with the new router ID. The next time a protocol is initialized, the new router ID is used. To force the new router ID, issue the **shutdown** and **no shutdown** commands for OSPF or restart the entire router.

Use the following CLI syntax to configure a router ID (in the **config>router** context):

**CLI syntax:**

```
router-id ip-address
```

The following displays a router ID configuration example:

```

A:ALU-B>config>router# info
#-----
# IP Configuration
#-----
    interface "system"
        address 10.10.10.104/8
    exit
    interface "to-103"
        address 10.0.0.104/8
        port 1/1/1
    exit
    router-id 10.10.10.104
...
#-----
A:ALU-B>config>router#

```

### 4.11.2 Configuring an OSPF area

An OSPF area consists of routers configured with the same area ID. To include a router in a specific area, the common area ID must be assigned and an interface identified.

If your network consists of multiple areas, you must also configure a backbone area (0.0.0.0) on at least one router. The backbone contains the area border routers and other routers not included in other areas. The backbone distributes routing information between areas. To maintain backbone connectivity, there

must be at least one interface in the backbone area or a virtual link must be configured to another router in the backbone area.

The minimal configuration must include an area ID and an interface. Modifying other command parameters is optional.

Use the following CLI syntax to configure an OSPF area (in the **config>router** context):

**CLI syntax:**

```
area area-id
  area-range ip-prefix/mask [advertise | not-advertise]
  blackhole-aggregate
```

The following displays an OSPF area configuration example:

```
A:ALU-A>config>router>ospf# info
```

```
-----
      area 0.0.0.0
      exit
      area 0.0.0.20
      exit
-----
```

```
ALU-A>config>router>ospf#
```

### 4.11.3 Configuring an interface

In OSPF, an interface can be configured to act as a connection between a router and one of its attached networks. An interface includes state information that was obtained from underlying lower-level protocols and from the routing protocol itself. An interface to a network is associated with a single IP address and mask (unless the network is an unnumbered point-to-point network). If the address is removed from an interface, all OSPF data for the interface is also removed. If the address is merely changed, the OSPF configuration is preserved.

The **passive** command enables the passive property to and from the OSPF interface where passive interfaces are advertised as OSPF interfaces but do not run the OSPF protocol. By default, only interface addresses that are configured for OSPF are advertised as OSPF interfaces. The **passive** parameter allows an interface to be advertised as an OSPF interface without running the OSPF protocol. When enabled, the interface will ignore ingress OSPF protocol packets and not transmit any OSPF protocol packets.

An interface can be associated with more than one area, as specified in RFC 5185. To enable an interface to be associated with multiple areas, include the **secondary** keyword when creating the interface.

Use the following CLI syntax to configure an OSPF interface in the **config>router** context:

**CLI syntax:**

```
ospf
  area area-id
    interface ip-int-name [secondary]
      advertise-subnet
      auth-keychain name
      authentication-key {authentication-key|hash-key} [hash|hash2]
      authentication-type [password | message-digest]
      bfd-enable [remain-down-on-failure]
      dead-interval seconds
      hello-interval seconds
      interface-type {broadcast|point-to-point}
      message-digest-key key-id md5 [key|hash-key] [hash|hash2]
      metric metric
```

```
mtu bytes
passive
priority number
retransmit-interval seconds
no shutdown
transit-delay seconds
```

The following displays an interface configuration example:

```
A:ALU-49>config>router>ospf# info
-----
asbr
overload
overload-on-boot timeout 60
traffic-engineering
export "OSPF-Export"
exit
area 0.0.0.0
  virtual-link 10.2.3.4 transit-area 1.2.3.4
  hello-interval 9
  dead-interval 40
  exit
  interface "system"
  exit
exit
area 0.0.0.20
  interface "to-103" secondary
  exit
exit
area 0.0.0.25
  nssa
  exit
exit
area 1.2.3.4
exit
-----
A:ALU-49>config>router>ospf#
```

## 4.12 Configuring other OSPF components

The following sections show the CLI syntax for:

- [Configuring a stub area](#)
- [Configuring a not-so-stubby area](#)
- [Configuring a virtual link](#)
- [Configuring authentication](#)
- [Assigning a designated router](#)
- [Configuring route summaries](#)
- [Configuring route preferences](#)

### 4.12.1 Configuring a stub area

Configure stub areas to control external advertisement flooding and to minimize the size of the topological databases on an area's routers. A stub area cannot also be configured as an NSSA. The area ID cannot be 0.0.0.0 – this address is reserved for the backbone area.

By default, summary route advertisements (type 3 LSAs) are sent into stub areas. The **no** form of the summary command disables sending summary route advertisements, and only the default route is advertised by the ABR.

Stub areas cannot be used as transit areas. If the area was originally configured as a transit area for a virtual link, existing virtual links are removed when its designation is changed to NSSA or stub.

Use the following CLI syntax to configure a stub area:

**CLI syntax:**

```
ospf
  area area-id
    stub
      default-metric metric
      summaries
```

The following displays a stub configuration example:

```
ALU-A>config>router>ospf>area># info
-----
...
    area 0.0.0.0
    exit
    area 0.0.0.20
        stub
        exit
    exit
```

### 4.12.2 Configuring a not-so-stubby area

NSSAs are similar to stub areas in that no external routes are imported into the area from other OSPF areas. The major difference between a stub area and an NSSA is that an NSSA can flood external routes that it learns throughout its area and from an area border router to the entire OSPF domain. An area cannot be both a stub area and an NSSA. The area ID cannot be 0.0.0.0 – this address is reserved for the backbone area.

NSSAs cannot be used as transit areas. If the area was originally configured as a transit area for a virtual link, existing virtual links are removed when its designation is changed to NSSA or stub.

Use the following CLI syntax to configure NSSAs:

**CLI syntax:**

```
ospf
  area area-id
    nssa
      area-range ip-prefix/mask [advertise | not-advertise]
      originate-default-route [type-7][no-adjacency-check]
      redistribute-external
      summaries
```

The following displays an NSSA configuration example:

```
A:ALU-49>config>router>ospf# info
-----
...
    area 0.0.0.25
        nssa
        exit
    exit
-----
A:ALU-49>config>router>ospf#
```

### 4.12.3 Configuring a virtual link

The backbone area (area 0.0.0.0) must be contiguous and all other areas must be connected to the backbone area. If it is not possible or practical to connect an area to the backbone, the area border routers must be connected via a virtual link. Two area border routers will form a point-to-point-like adjacency across the transit area. A virtual link can only be configured while in the context of area 0.0.0.0. The transit area cannot be a stub area or an NSSA.

The *router-id* parameter specified in the **virtual-link** command must be associated with the virtual neighbor; that is, the router ID of the far-end router must be specified, not the local router ID.

Use the following CLI syntax to configure a virtual link:

#### CLI syntax:

```
ospf
  area area-id
    virtual-link router-id transit-area area-id
      auth-keychain name
      authentication-key {authentication-key | hash-key} [hash |
hash2]
      authentication-type [password | message-digest]
      dead-interval seconds
      hello-interval seconds
      message-digest-key key-id md5 [key | hash-key] [hash | hash2]
      retransmit-interval seconds
      transit-delay
      no shutdown
```

The following displays a virtual link configuration example:

```
A:ALU-49>config>router>ospf# info
-----
...
    area 0.0.0.0
        virtual-link 10.2.3.4 transit-area 1.2.3.4
            hello-interval 9
            dead-interval 40
        exit
    exit
    area 0.0.0.20
        stub
        exit
    exit
    area 0.0.0.25
        nssa
        exit
    exit
```



```
area 1.2.3.4
exit
```

## 4.12.4 Configuring authentication

Authentication must be explicitly configured and can be done using two separate mechanisms:

- configuration of an explicit authentication key and algorithm using the **authentication-key** and **authentication-type** commands at the interface level or the virtual link level
- configuration of an authentication keychain using the **auth-keychain** command in the **config>system>security>keychain** context and associating the keychain with the interface or virtual link

Either the **authentication-key** command or the **auth-keychain** command can be used by OSPF, but both cannot be supported at the same time. If both commands are configured, the **auth-keychain** configuration will be applied and the **authentication-key** command will be ignored.

Use the following CLI syntax to configure authentication:

### CLI syntax:

```
ospf
  area area-id
    interface ip-int-name
      authentication-key {authentication-key | hash-key} [hash |
hash2]
      authentication-type [password | message-digest]
      message-digest-key key-id md5 [key | hash-key] [hash | hash2]
    virtual-link router-id transit-area area-id
      authentication-key {authentication-key | hash-key} [hash |
hash2]
      authentication-type [password | message-digest]
      message-digest-key key-id md5 [key | hash-key] [hash | hash2]
```

The following displays authentication configuration examples:

```
A:ALU-49>config>router>ospf# info
-----
...
    area 0.0.0.40
      interface "test1"
        authentication-type password
        authentication-key "3WErEDoZxyQ" hash
      exit
    exit
  area 1.2.3.4
  exit
-----
A:ALU-49>config>router>ospf#
```

```
A:ALU-49>config>router>ospf# info
-----
...
    area 0.0.0.0
      virtual-link 10.0.0.1 transit-area 0.0.0.1
      authentication-type message-digest
```

```

        message-digest-key 2 md5 "Mi6BQAFi3MI" hash
    exit
    virtual-link 10.2.3.4 transit-area 1.2.3.4
        hello-interval 9
        dead-interval 40
    exit
    interface "system"
    exit
exit
-----
A:ALU-49>config>router>ospf#

```

Use the following CLI syntax to associate an interface or virtual link with an authentication keychain. The keychain must already be defined in the **system>security>keychain** context.

**CLI syntax:**

```

ospf
  area area-id
    interface ip-int-name
      auth-keychain name
    virtual-link router-id transit-area area-id
      auth-keychain name

```

#### 4.12.5 Assigning a designated router

The designated router is responsible for flooding network link advertisements on a broadcast network to describe the routers attached to the network. A router uses Hello packets to advertise its priority. The router with the highest-priority interface becomes the designated router. If routers have the same priority, the designated router is elected based on the highest router ID. A router with priority 0 is not eligible to be a designated router or a backup designated router. At least one router on each logical IP network or subnet must be eligible to be the designated router. By default, routers have a priority value of 1.

When a router starts up, it checks for a current designated router. If a designated router is present, the router accepts that designated router, regardless of its own priority designation. If the designated and backup designated routers fail, new designated and backup routers are elected according to their priority numbers or router IDs (in case of a priority tie).

Designated routers are used only in multi-access (broadcast) networks.

Use the following CLI syntax to configure the designated router:

**CLI syntax:**

```

ospf
  area area-id
    interface ip-int-name
      priority number

```

The following displays a priority designation example:

```

A:ALU-49>config>router>ospf# info
-----
...
    area 0.0.0.25
      nssa
    exit
    interface "if2"
      priority 100

```

```

        exit
      exit
-----
A:ALU-49>config>router>ospf#

```

### 4.12.6 Configuring route summaries

ABRs send summary advertisements (type 3 LSAs) into a stub area or NSSA to describe the routes to other areas. This command is particularly useful in order to reduce the size of the link-state database within the stub or NSSA.

By default, summary route advertisements are sent into the stub area or NSSA. The **no** form of the **summaries** command disables sending summary route advertisements and, in stub areas, the default route is advertised by the area border router.

Use the following CLI syntax to configure a route summary:

#### CLI syntax:

```

ospf
  area area-id
    stub
      summaries
    nssa
      summaries

```

The following displays a stub route summary configuration example:

```

A:ALU-49>config>router>ospf# info
-----
...
      area 0.0.0.20
        stub
          summaries
        exit
      interface "to-103"
        exit
      exit
-----
A:ALU-49>config>router>ospf#

```

### 4.12.7 Configuring route preferences

A router can learn routes from different protocols and distribute them into OSPF, in which case, the costs are not comparable. When this occurs, the preference value is used to decide which route is installed in the forwarding table and used as the path to the destination. The route with the lowest preference value is selected.

The 7705 SAR supports the redistribution of static routes and routes from directly attached and aggregated networks into OSPF.

Different protocols should not be configured with the same preference. If this occurs, the tiebreaker is based on the default preferences as defined in [Table 37: Route preference defaults by route type](#).

If multiple routes are learned with an identical preference using the same protocol, the lowest-cost route is used. If multiple routes are learned with an identical preference using the same protocol and the costs

(metrics) are equal, the decision of what route to use is determined by the configuration of ECMP in the **config>router** context. See the 7705 SAR Router Configuration Guide for information about ECMP.

Table 37: Route preference defaults by route type

Route type	Preference	Configurable
Direct attached	0	No
Static routes	5	Yes
OSPF internal	10	Yes
IS-IS level 1 internal	15	Yes
IS-IS level 2 internal	18	Yes
OSPF external	150	Yes
IS-IS level 1 external	160	Yes
IS-IS level 2 external	165	Yes



**Note:** To configure a preference for static routes, use the **config>router>static-route-entry** context. See the 7705 SAR Router Configuration Guide, "IP Router Command Reference", for information.

Use the following CLI syntax to configure a route preference for OSPF internal and external routes:

**CLI syntax:**

```
ospf
  preference preference
  external-preference preference
```

The following displays a route preference configuration example:

```
A:ALU-49>config>router>ospf# info
-----
      asbr
      overload
      overload-on-boot timeout 60
      traffic-engineering
      preference 9
      external-preference 140
      exit
-----
A:ALU-49>config>router>ospf#
```

## 4.13 OSPF configuration management tasks

This section discusses the following OSPF configuration management tasks:

- [Modifying a router ID](#)
- [Deleting a router ID](#)

- [Modifying OSPF parameters](#)

### 4.13.1 Modifying a router ID

Because the router ID is defined in the **config>router** context, not in the OSPF configuration context, the protocol instance is not aware of changes to the ID value. Changing the router ID on a device could cause configuration inconsistencies if associated values are not also modified.

After you have changed a router ID, manually shut down and restart the protocol using the **shutdown** and **no shutdown** commands in order for the changes to be incorporated.

Use the following CLI syntax to change a router ID number:

**CLI syntax:**

```
config>router# router-id ip-address
```

The following displays an NSSA router ID modification example:

```
A:ALU-49>config>router# info
-----
IP Configuration
-----
    interface "system"
      address 10.10.10.104/8
    exit
    interface "to-103"
      address 10.0.0.103/8
      port 1/1/1
    exit
    router-id 10.10.10.104
-----
A:ALU-49>config>router#
```

### 4.13.2 Deleting a router ID

You can modify a router ID, but you cannot delete the parameter. If the **no router router-id** command is issued, the router ID reverts to the default value, the system interface address (which is also the loopback address). If a system interface address is not configured, the last 4 bytes of the chassis MAC address are used as the router ID.

### 4.13.3 Modifying OSPF parameters

You can change or remove existing OSPF parameters in the CLI. The changes are applied immediately.

The following example displays an OSPF modification in which an interface is removed and another interface added.

**Example:**

```
config>router# ospf
config>router>ospf# area 0.0.0.20
config>router>ospf>area# no interface "to-103"
config>router>ospf>area# interface "to-HQ"
config>router>ospf>area>if$ priority 50
config>router>ospf>area>if# exit
```

```
config>router>ospf>area# exit
```

The following example displays the OSPF configuration with the modifications entered in the previous example:

```
A:ALU-49>config>router>ospf# info
-----
    asbr
    external-preference 140
    export "OSPF-Export"
    overload
    overload-on-boot timeout 60
    preference 9
    traffic-engineering
    exit
    area 0.0.0.0
        virtual-link 10.0.0.1 transit-area 0.0.0.1
            authentication-type message-digest
            message-digest-key 2 md5 "Mi6BQAFi3MI" hash
        exit
        virtual-link 10.2.3.4 transit-area 1.2.3.4
            hello-interval 9
            dead-interval 40
        exit
        interface "system"
        exit
    exit
    area 0.0.0.1
    exit
    area 0.0.0.20
        stub
        exit
        interface "to-HQ"
            priority 50
        exit
    exit
-----
A:ALU-49>config>router>ospf#
```

## 4.14 OSPF command reference

### 4.14.1 Command hierarchies

- [Configuration commands](#)
- [Show commands](#)
- [Clear commands](#)
- [Monitor commands](#)
- [Debug commands](#)
- Tools Commands (see the Tools chapter in the 7705 SAR OAM and Diagnostics Guide)

#### 4.14.1.1 Configuration commands

```

config
- router
  - [no] ospf
    - advertise-router-capability {link | area | as}
    - no advertise-router-capability
    - [no] advertise-tunnel-link
    - [no] area area-id
      - [no] advertise-router-capability
      - area-range ip-prefix/mask [advertise | not-advertise]
      - no area-range ip-prefix/mask
      - [no] blackhole-aggregate
      - interface ip-int-name [secondary]
      - no interface ip-int-name
        - adjacency-sid label value
        - no adjacency-sid
        - [no] advertise-router-capability
        - [no] advertise-subnet
        - auth-keychain name
        - no auth-keychain
        - authentication-key {authentication-key | hash-key} [hash | hash2]
        - no authentication-key
        - authentication-type {password | message-digest}
        - no authentication-type
        - bfd-enable [remain-down-on-failure]
        - no bfd-enable
        - dead-interval seconds
        - no dead-interval
        - hello-interval seconds
        - no hello-interval
        - interface-type {broadcast | point-to-point}
        - no interface-type
        - lfa-policy-map route-nh-template template-name
        - no lfa-policy-map
        - [no] loopfree-alternate-exclude
        - message-digest-key key-id md5 {key | hash-key} [hash | hash2]
        - no message-digest-key key-id
        - metric metric
        - no metric
        - mtu bytes
        - no mtu

```

```

- node-sid index index-value
- node-sid label label-value
- no node-sid
- [no] passive
- priority number
- no priority
- retransmit-interval seconds
- no retransmit-interval
- [no] shutdown
- [no] sid-protection
- transit-delay seconds
- no transit-delay
- [no] loopfree-alternate-exclude
- [no] nssa
  - area-range ip-prefix/mask [advertise | not-advertise]
  - no area-range ip-prefix/mask
  - originate-default-route [type-7] [no-adjacency-check]
  - no originate-default-route
  - [no] redistribute-external
  - [no] summaries
- [no] stub
  - default-metric metric
  - no default-metric
  - [no] summaries
- [no] virtual-link router-id transit-area area-id
  - auth-keychain name
  - no auth-keychain
  - authentication-key {authentication-key | hash-key} [hash | hash2]
  - no authentication-key
  - authentication-type {password | message-digest}
  - no authentication-type
  - dead-interval seconds
  - no dead-interval
  - hello-interval seconds
  - no hello-interval
  - message-digest-key key-id md5 {key | hash-key} [hash | hash2]
  - no message-digest-key key-id
  - retransmit-interval seconds
  - no retransmit-interval
  - [no] shutdown
  - transit-delay seconds
  - no transit-delay
- [no] asbr [trace-path domain-id]
- database-export [identifier id] [bgp-ls-identifier bgp-ls-id]
- no database-export
- [no] disable-ldp-sync
- entropy-label
  - [no] override-tunnel-elc
- export policy-name [policy-name...(up to 5 max)]
- no export
- external-db-overflow limit seconds
- no external-db-overflow
- external-preference preference
- no external-preference
- [no] graceful-restart
  - [no] helper-disable
- import policy-name [policy-name...(up to 5 max)]
- no import
- [no] loopfree-alternates
  - exclude
    - prefix-policy prefix-policy [prefix-policy...(up to 5 max)]
    - no prefix-policy
  - remote-lfa [max-pq-cost value]
  - no remote-lfa

```



```

- node-protect [max-pq-nodes value]
- no node-protect
- ti-lfa [max-sr-frr-labels value]
- no ti-lfa
- [no] node-protect
- overload [timeout seconds]
- no overload
- [no] overload-include-stub
- overload-on-boot [timeout seconds]
- no overload-on-boot
- preference preference
- no preference
- reference-bandwidth bandwidth-in-kbps
- reference-bandwidth [tbps Tera-bps] [gbps Giga-bps] [mbps Mega-bps] [kbits Kilo-
bps]
- no reference-bandwidth
- router-id ip-address
- no router-id
- [no] rsvp-shortcut
- [no] segment-routing
- adj-sid-hold seconds
- no adj-sid-hold
- backup-node-sid ip-prefix/prefix-length index [0..4294967295]
- backup-node-sid ip-prefix/prefix-length label [1..4294967295]
- no backup-node-sid
- entropy-label {force-disable | enable}
- no entropy-label
- prefix-sid-range global
- prefix-sid-range start-label label-value max-index index-value
- no prefix-sid-range
- [no] shutdown
- srlb reserved-label-block-name
- no srlb
- tunnel-mtu bytes
- no tunnel-mtu
- tunnel-table-pref preference
- no tunnel-table-pref
- [no] shutdown
- timers
- lsa-arrival lsa-arrival-time
- no lsa-arrival
- lsa-generate max-lsa-wait [lsa-initial-wait [lsa-second-wait]]
- no lsa-generate
- spf-wait max-spf-wait [spf-initial-wait spf-initial-wait] [spf-second-
wait spf-second-wait]
- no spf-wait
- [no] traffic-engineering
- [no] unicast-import-disable
config
- router
- [no] ospf3
- advertise-router-capability {link | area | as}
- no advertise-router-capability
- [no] area area-id
- [no] advertise-router-capability
- area-range ipv6-prefix/prefix-length [advertise | not-advertise]
- no area-range ipv6-prefix/prefix-length
- [no] blackhole-aggregate
- interface ip-int-name [secondary]
- no interface ip-int-name
- [no] advertise-router-capability
- authentication bidirectional sa-name
- authentication inbound sa-name outbound sa-name
- no authentication

```

```

- bfd-enable [remain-down-on-failure]
- no bfd-enable
- dead-interval seconds
- no dead-interval
- hello-interval seconds
- no hello-interval
- interface-type {broadcast | point-to-point}
- no interface-type
- lfa-policy-map route-nh-template template-name
- no lfa-policy-map
- [no] loopfree-alternate-exclude
- metric metric
- no metric
- mtu bytes
- no mtu
- [no] passive
- priority number
- no priority
- retransmit-interval seconds
- no retransmit-interval
- [no] shutdown
- transit-delay seconds
- no transit-delay
- key-rollover-interval seconds
- no key-rollover-interval
- [no] loopfree-alternate-exclude
- [no] nssa
  - area-range ipv6-prefix/prefix-length [advertise | not-advertise]
  - no area-range ipv6-prefix/prefix-length
  - originate-default-route [type-nssa] [no-adjacency-check]
  - no originate-default-route
  - [no] redistribute-external
  - [no] summaries
- [no] stub
  - default-metric metric
  - no default-metric
  - [no] summaries
- [no] virtual-link router-id transit-area area-id
  - authentication bidirectional sa-name
  - authentication inbound sa-name outbound sa-name
  - no authentication
  - dead-interval seconds
  - no dead-interval
  - hello-interval seconds
  - no hello-interval
  - retransmit-interval seconds
  - no retransmit-interval
  - [no] shutdown
  - transit-delay seconds
  - no transit-delay
- [no] asbr
- export policy-name [policy-name... (up to 5 max)]
- no export
- external-db-overflow limit seconds
- no external-db-overflow
- external-preference preference
- no external-preference
- [no] loopfree-alternates
  - exclude
    - prefix-policy prefix-policy [prefix-policy... (up to 5 max)]
    - no prefix-policy
- [no] multicast-import
- overload [timeout seconds]
- no overload

```

```

- [no] overload-include-stub
- overload-on-boot [timeout seconds]
- no overload-on-boot
- preference preference
- no preference
- reference-bandwidth bandwidth-in-kbps
- reference-bandwidth [tbps Tera-bps] [gbps Giga-bps] [mbps Mega-bps] [kpbs Kilo-
bps]
- no reference-bandwidth
- router-id ip-address
- no router-id
- [no] shutdown
- timers
  - lsa-arrival lsa-arrival-time
  - no lsa-arrival
  - lsa-generate max-lsa-wait [lsa-initial-wait [lsa-second-wait]]
  - no lsa-generate
  - spf-wait max-spf-wait [spf-initial-wait spf-initial-wait] [spf-second-
wait spf-second-wait]
  - no spf-wait
- [no] unicast-import-disable

```

#### 4.14.1.2 Show commands

```

show
- router [router-instance]
- router service-name [service-name]
  - ospf [all]
    - area [area-id] [detail] [lfa]
    - capabilities [router-id]
    - database [type {router | network | summary | asbr-summary | external | nssa |
all} [area area-id] [adv-router router-id] [link-state-id] [detail] [filtered]
    - interface [area area-id] [detail]
    - interface [ip-int-name | ip-address] [detail]
    - interface [ip-int-name | ip-address] database [detail]
    - lfa-coverage
    - neighbor [ip-int-name | ip-address] [detail]
    - neighbor overview
    - neighbor [remote ip-address] [detail]
    - opaque-database [area area-id | as] [adv-router router-id] [ls-id] [detail]
    - prefix-sids [ip-prefix[/prefix-length]] [sid sid] [adv-router router-id]
    - range [area-id]
    - routes [ip-prefix[/prefix-length]] [type] [detail] [alternative] [summary]
  [exclude-shortcut]
    - sham-link [interface-name] [detail]
    - sham-link interface-name remote ip-address [detail]
    - sham-link-neighbor [detail]
    - sham-link-neighbor interface-name remote ip-address [detail]
    - spf [lfa]
    - statistics
    - status
    - virtual-link database [detail]
    - virtual-link [detail]
    - virtual-neighbor [remote ip-address] [detail]
  - ospf3 [all]
    - area [area-id] [detail] [lfa]
    - capabilities [router-id]
    - database [type database-type] [area area-id] [adv-router router-id] [link-state-
id] [detail] [filtered]
    - interface [area area-id] [detail]
    - interface [ip-int-name | ip-address | ipv6-address] [detail]

```

```

- interface [ip-int-name | ip-address | ipv6-address] database [detail]
- lfa-coverage
- neighbor [ip-int-name] [router-id] [detail]
- neighbor overview
- range [area-id]
- routes [ip-prefix[/pfx-len]] [type] [detail] [alternative] [summary]
- spf [lfa]
- statistics
- status
- virtual-link [detail]
- virtual-neighbor [remote ipv6-address] [detail]

```

#### 4.14.1.3 Clear commands

```

clear
- router
  - ospf
    - database [purge]
    - export
    - neighbor [ip-int-name | ip-address]
    - statistics
  - ospf3
    - database [purge]
    - export
    - neighbor [ip-int-name | ip-address]
    - statistics

```

#### 4.14.1.4 Monitor commands

```

monitor
- router
  - ospf
    - interface interface [interface...(up to 5 max)] [interval seconds]
    [repeat repeat] [absolute | rate]
    - neighbor ip-address [ip-address...(up to 5 max)] [interval seconds]
    [repeat repeat] [absolute | rate]
    - virtual-link nbr-rtr-id area area-id [interval seconds] [repeat repeat] [absolute
    | rate]
    - virtual-neighbor nbr-rtr-id area area-id [interval seconds] [repeat repeat]
    [absolute | rate]
  - ospf3
    - interface interface [interface...(up to 5 max)] [interval seconds]
    [repeat repeat] [absolute | rate]
    - neighbor router-id ip-int-name [interval seconds] [repeat repeat] [absolute |
    rate] area area-id
    - virtual-link nbr-rtr-id area area-id [interval seconds] [repeat repeat] [absolute
    | rate]
    - virtual-neighbor nbr-rtr-id transit-area transit-area [interval seconds]
    [repeat repeat] [absolute | rate]

```

#### 4.14.1.5 Debug commands

```

debug
- router
  - ospf

```

```

- area [area-id]
- no area
- area-range [ip-address]
- no area-range
- cspf [ip-address]
- no cspf
- interface [ip-int-name | ip-address]
- no interface
- leak [ip-address]
- no leak
- lsdb [type] [ls-id] [adv-rtr-id] [area area-id]
- no lsdb
- [no] misc
- neighbor [ip-int-name | router-id]
- no neighbor
- nssa-range [ip-address]
- no nssa-range
- packet [packet-type] [ip-address]
- no packet
- rsvp-shortcut [ip-address]
- no rsvp-shortcut
- rtm [ip-address]
- no rtm
- sham-neighbor [ip-address]
- no sham-neighbor
- spf [type] [dest-addr]
- no spf
- virtual-neighbor [ip-address]
- no virtual-neighbor
- ospf3
- area [area-id]
- no area
- area-range [ip-address]
- no area-range
- interface [ip-int-name | ip-address]
- no interface
- leak [ip-address]
- no leak
- lsdb [type] [ls-id] [adv-rtr-id] [area area-id]
- no lsdb
- [no] misc
- neighbor [ip-int-name | router-id]
- no neighbor
- nssa-range [ip-address]
- no nssa-range
- packet [packet-type] [ip-address]
- no packet
- rsvp-shortcut [ip-address]
- no rsvp-shortcut
- spf [type] [dest-addr]
- no spf
- virtual-neighbor [ip-address]
- no virtual-neighbor

```

## 4.14.2 Command descriptions

- [Configuration commands](#)
- [Show commands](#)
- [Clear commands](#)
- [Monitor commands](#)
- [Debug commands](#)

### 4.14.2.1 Configuration commands

- [Generic commands](#)
- [Global commands](#)
- [Area commands](#)
- [Interface/virtual link commands](#)

#### 4.14.2.1.1 Generic commands

## shutdown

### Syntax

[no] shutdown

### Context

```
config>router>ospf
config>router>ospf>area>interface
config>router>ospf>area>segment-routing
config>router>ospf>area>virtual-link
config>router>ospf3
config>router>ospf3>area>interface
config>router>ospf3>area>virtual-link
```

### Description

This command administratively disables the entity. When disabled, an entity does not change, reset, or remove any configuration settings or statistics. Many entities must be explicitly enabled using the **no shutdown** command.

The operational state of the entity is disabled as well as the operational state of any entities contained within. Many objects must be shut down before they can be deleted.

Unlike other commands and parameters where the default state is not indicated in the configuration file, **shutdown** and **no shutdown** are always indicated in system-generated configuration files.

The **no** form of the command puts an entity into the administratively enabled state.

### Default

OSPF protocol – the OSPF protocol is created in the **no shutdown** state

OSPF interface – when an IP interface is configured as an OSPF interface, OSPF on the interface is in the **no shutdown** state by default

## 4.14.2.1.2 Global commands

```
ospf
```

### Syntax

```
[no] ospf
```

### Context

```
config>router
```

### Description

This command activates OSPF on the router and enables access to the context to define OSPF parameters.

Before OSPF can be activated on the router, the router ID must be configured.

The router ID uniquely identifies the router within an AS. In OSPF, routing information is exchanged between autonomous systems, which are groups of networks that share routing information. The router ID can be set to be the same as the system interface address (loopback address).

The router ID is derived by one of the following methods:

- defining the value using the **config>router>router-id** *ip-address* command
- defining the system interface using the **config>router>interface** *ip-int-name* command (used if the router ID is not specified with the **config>router>router-id** *ip-address* command)
- inheriting the last 4 bytes of the MAC address

When configuring a new router ID, protocols are not automatically restarted with the new router ID. The next time a protocol is initialized, the new router ID is used. To force the new router ID, issue the **shutdown** and **no shutdown** commands for OSPF or restart the entire router.

The **no** form of the command reverts to the default value.

### Default

```
no ospf
```

## ospf3

### Syntax

```
[no] ospf3
```

### Context

```
config>router
```

### Description

This command activates OSPFv3 on the router and enables access to the context to define OSPFv3 parameters.

Before OSPFv3 can be activated on the router, the router ID must be configured.

The router ID uniquely identifies the router within an AS. In OSPFv3, routing information is exchanged between autonomous systems, which are groups of networks that share routing information. The router ID can be set to be the same as the system interface address (loopback address).

The router ID is derived by one of the following methods:

- defining the value using the **config>router>router-id** *ip-address* command
- defining the system interface using the **config>router>interface** *ip-int-name* command (used if the router ID is not specified with the **config>router>router-id** *ip-address* command)
- inheriting the last 4 bytes of the MAC address

When configuring a new router ID, protocols are not automatically restarted with the new router ID. The next time a protocol is initialized, the new router ID is used. To force the new router ID, issue the **shutdown** and **no shutdown** commands for OSPFv3 or restart the entire router.

The **no** form of the command reverts to the default value.

### Default

```
no ospf3
```

## advertise-router-capability

### Syntax

```
advertise-router-capability {link | area | as}  
no advertise-router-capability
```

### Context

```
config>router>ospf
```

```
config>router>ospf3
```



## Description

This command enables advertisement of a router's capabilities to its neighbors for informational and troubleshooting purposes. A Router Information (RI) LSA as defined in RFC 4970 advertises the following capabilities:

- OSPF graceful restart capable: no
- OSPF graceful restart helper: yes, when enabled
- OSPF stub router support: yes
- OSPF traffic engineering support: yes, when enabled
- OSPF point-to-point over LAN: yes
- OSPF experimental TE: no

The parameters (**link**, **area** and **as**) control the scope of the capability advertisements.

The **no** form of this command disables this capability.

## Default

no advertise-router-capability

## Parameters

### link

capabilities are only advertised over local links and not flooded beyond

### area

capabilities are only advertised within the area of origin

### as

capabilities are advertised throughout the entire autonomous system

## advertise-tunnel-link

## Syntax

```
[no] advertise-tunnel-link
```

## Context

```
config>router>ospf
```

## Description

This command enables the forwarding adjacency feature. With this feature, OSPF advertises an RSVP-TE LSP as a link so that other routers in the network can include it in their SPF calculations. The RSVP-TE LSP is advertised as an unnumbered point-to-point link and the link-state advertisement (LSA) has no traffic engineering opaque sub-TLVs as per RFC 3906.

The forwarding adjacency feature can be enabled independently from the IGP shortcut feature ([rsvp-shortcut](#)). If both features are enabled in OSPF, the forwarding adjacency feature takes precedence.

When this feature is enabled, each node advertises a point-to-point unnumbered link for each best-metric tunnel to the router ID of any endpoint node. The node does not include the tunnels as IGP shortcuts in the

SPF calculation directly. Instead, when the LSA advertising the corresponding point-to-point unnumbered link is installed in the local routing database, the node performs an SPF calculation using the link like any other link LSA.

The link bidirectional check requires that a regular link or tunnel link exists in the reverse direction for the tunnel to be used in the SPF calculation.

An RSVP-TE LSP can be excluded from being used as a forwarding adjacency with the **config>router>mpls>lsp>no igp-shortcut** command.

The **no** form of this command disables forwarding adjacency and therefore disables the advertisement of RSVP-TE LSPs into OSPF.

## Default

no advertise-tunnel-link

## asbr

## Syntax

[no] **asbr** [**trace-path** *domain-id*]

## Context

config>router>ospf

config>router>ospf3

## Description

This command configures the router as an autonomous system boundary router (ASBR) if the router is to be used to distribute external routes into the OSPF domain. When a router is configured as an ASBR, the export policies into the OSPF domain take effect. If no policies are configured, no external routes are redistributed into the OSPF domain.

The **no** form of the command removes the ASBR status and withdraws the routes redistributed from the routing table into OSPF from the link-state database.

Only the base OSPF instance is supported; therefore, the domain ID may not need to be configured. However, in order to prevent routing loops (where routes learned from one domain are redistributed back into the domain), the domain ID can be used to tag external LSAs – indicating which domain or network they have learned the route from.

## Default

no asbr – the router is not an ASBR

## Parameters

*domain-id*

specifies the domain ID

**Values** 1 to 31

**Default** 0x0

## database-export

### Syntax

```
database-export [identifier id] [bgp-ls-identifier bgp-ls-id]  
no database-export
```

### Context

```
config>router>ospf
```

### Description

This command enables the population of the extended TE database (TE-DB) with the link-state information from OSPF.

The extended TE-DB is used as a central point for importing all link-state, link, node, and prefix information from IGP instances on the router and exporting the information to BGP-LS on the router. This information includes the IGP, TE, SID sub-TLV, and adjacency SID sub-TLV.

The **no** form of this command disables database exportation.

### Default

```
no database-export
```

### Parameters

#### identifier

uniquely identifies the IGP instance in the BGP-LS NLRI when a router has interfaces participating in multiple IGP instances. This parameter defaults to the IGP instance ID assigned by the 7705 SAR. However, because the concept of instance ID defined in IS-IS (RFC 6822) is unique within a routing domain while the one specified for OSPF is significant for the local subnet only (RFC 6549), the user can remove any overlap by configuring the new **identifier** value to be unique within a particular IGP domain when this router sends the IGP link-state information using BGP-LS.

#### *id*

specifies an entry ID to export

**Values** 0 to 18446744073709551615

#### bgp-ls-identifier

used with the autonomous system number (ASN) to correlate the BGP-LS NLRI advertisements of multiple BGP-LS speakers in the same IGP domain. If an NRC-P network domain has multiple IGP domains, BGP-LS speakers in each IGP domain must be configured with the same unique tuple {bgp-ls-identifier, asn}.

The BGP-LS identifier is optional and is only sent in a BGP-LS NLRI if configured in the IGP instance of an IGP domain.

If this IGP instance participates in traffic engineering with RSVP-TE or SR-TE, the [traffic-engineering](#) option is not strictly required because enabling the extended TE-DB populates this information automatically. However, it is recommended that the enable traffic

engineering to make the configuration consistent with other routers in the network that do not require enabling of the extended TE-DB.

*bgp-ls-id*

specifies a BGP LS ID to export

**Values** 0 to 4294967295

## disable-ldp-sync

### Syntax

[no] **disable-ldp-sync**

### Context

config>router>ospf

### Description

This command disables the IGP-LDP synchronization feature on all interfaces participating in the OSPF or IS-IS routing protocol. When this command is executed, IGP immediately advertises the actual value of the link cost for all interfaces that have the IGP-LDP synchronization enabled if the currently advertised cost is different. IGP-LDP synchronization will then be disabled for all interfaces. This command does not delete the interface configuration.

The **no** form of this command restores the default settings and re-enables IGP-LDP synchronization on all interfaces participating in the OSPF or IS-IS routing protocol and for which the **ldp-sync-timer** is configured (see the 7705 SAR Router Configuration Guide for information about configuring the **ldp-sync-timer**).

### Default

no disable-ldp-sync

## entropy-label

### Syntax

**entropy-label**

### Context

config>router>ospf

### Description

This command enables the context for the configuration of entropy label capabilities for the routing protocol.

## override-tunnel-elc

### Syntax

```
[no] override-tunnel-elc
```

### Context

```
config>router>ospf>entropy-label
```

### Description

This command configures the ability to override any received entropy label capability advertisements. When enabled, the system assumes that all nodes for an IGP domain are capable of receiving and processing the entropy label on segment routed tunnels. This command can only be configured if **entropy-label** is enabled via the **config>router>ospf>segment-routing>entropy-label** command.

The **no** version of this command disables the override. The system assumes entropy label capability for other nodes in the IGP instance if capability advertisements are received.

### Default

```
no override-tunnel-elc
```

## export

### Syntax

```
export policy-name [policy-name...(up to 5 max)]
```

```
no export
```

### Context

```
config>router>ospf
```

```
config>router>ospf3
```

### Description

This command specifies export route policies to determine which routes are exported from the routing table manager to OSPF. Export policies are only in effect if OSPF is configured as an ASBR.

If no export policy is specified, non-OSPF routes are not exported from the routing table manager to OSPF.

If multiple policy names are specified, the policies are evaluated in the order they are specified. The first policy that matches is applied. If multiple export commands are issued, the last command entered will override the previous command. A maximum of five policy names can be specified.

The **no** form of the command removes all policies from the configuration.

See the 7705 SAR Router Configuration Guide for information about defining route policies.

### Default

```
no export
```

## Parameters

*policy-name*

the export route policy name. Allowed values are any string up to 32 characters long composed of printable, 7-bit ASCII characters. If the string contains special characters (such as #, \$, or spaces), the entire string must be enclosed within double quotes.

The specified names must already be defined.

## external-db-overflow

### Syntax

**external-db-overflow** *limit seconds*

**no external-db-overflow**

### Context

config>router>ospf

config>router>ospf3

### Description

This command enables limits on the number of non-default, AS-external LSA entries that can be stored in the link-state database (LSDB) and specifies a wait timer before processing these entries after the limit is exceeded.

The *limit* value specifies the maximum number of entries that can be stored in the LSDB. Placing a limit on these LSAs in the LSDB protects the router from receiving an excessive number of external routes that consume excessive memory or CPU resources. If the number of routes reaches or exceeds the *limit*, the table is in an overflow state. When in an overflow state, the router will not originate any new AS-external LSAs and will withdraw all the self-originated non-default external LSAs.

The *seconds* value specifies the time to wait after an overflow state before regenerating and processing non-default, AS-external LSAs. The waiting period acts like a dampening period, preventing the router from continuously running shortest path first (SPF) calculations caused by the excessive number of non-default, AS-external LSAs.

The **external-db-overflow** must be set identically on all routers attached to any regular OSPF area. OSPF stub areas and not-so-stubby areas (NSSAs) are excluded.

The **no** form of the command disables limiting the number of non-default, AS-external LSA entries.

### Default

no external-db-overflow

### Parameters

*limit*

the maximum number of non-default, AS-external LSA entries that can be stored in the LSDB before going into an overflow state, expressed as a decimal integer

**Values** 0 to 2147483674

*seconds*

the number of seconds after entering an overflow state before attempting to process non-default, AS-external LSAs, expressed as a decimal integer

**Values** 0 to 2147483674

## external-preference

### Syntax

**external-preference** *preference*

**no external-preference**

### Context

config>router>ospf

config>router>ospf3

### Description

This command configures the preference for OSPF external routes. The preference for internal routes is set with the [preference](#) command.

A route can be learned by the router from different protocols, in which case, the costs are not comparable. When this occurs, the preference is used to decide which route will be used.

Different protocols should not be configured with the same preference. If this occurs, the tiebreaker is based on the default preferences as defined in the following table.

*Table 38: Route preference defaults by route type*

Route type	Preference	Configurable
Direct attached	0	No
Static routes	5	Yes
OSPF internal	10	Yes
IS-IS level 1 internal	15	Yes
IS-IS level 2 internal	18	Yes
OSPF external	150	Yes
IS-IS level 1 external	160	Yes
IS-IS level 2 external	165	Yes

If multiple routes are learned with the same preference using the same protocol, the lowest-cost route is used. If multiple routes are learned with the same preference using the same protocol and the costs (metrics) are equal, the decision of which route to use is determined by the configuration of ECMP in the **config>router** context. See the 7705 SAR Router Configuration Guide for information about ECMP.



**Note:** To configure a preference for static routes, use the **config>router>static-route-entry** context. See the 7705 SAR Router Configuration Guide for information.

The **no** form of the command reverts to the default value.

### Default

external-preference 150 – OSPF external routes have a default preference of 150

### Parameters

*preference*

the preference for external routes, expressed as a decimal integer

**Values** 1 to 255

## graceful-restart

### Syntax

[no] graceful-restart

### Context

config>router>ospf

### Description

This command enables or disables graceful restart for OSPF. Graceful restart is not fully implemented on the 7705 SAR, meaning that the router will never request graceful restart support from its neighbors. However, graceful restart must be enabled before the 7705 SAR can be configured for graceful restart helper mode.

The **no** form of the command disables graceful restart and removes all graceful restart configurations in OSPF.

### Default

no graceful-restart

## helper-disable

### Syntax

[no] helper-disable

### Context

config>router>ospf>graceful-restart



## Description

This command enables or disables graceful restart helper mode for OSPF. In helper mode, if a grace LSA is received from an OSPF neighbor, the 7705 SAR keeps the link toward that neighbor up and operational until the specified grace period in the grace LSA expires or the graceful restart is successful, whichever comes first.

The **no** form of the command enables graceful restart helper mode and is the default when **graceful-restart** is enabled.

## Default

no helper-disable

## import

## Syntax

**import** *policy-name* [*policy-name...*(up to 5 max)]

**no import**

## Context

config>router>ospf

## Description

This command configures up to five import route policies that determine which routes are imported into the routing table.

When a prefix received in an OSPF LSA is accepted by an entry in an OSPF import policy, it is installed in the routing table if it is the most preferred route to the destination. When a prefix received in an OSPF LSA is rejected by an entry in an OSPF import policy, it is not installed in the routing table, even if it has the lowest preference value among all the routes to that destination.

The flooding of LSAs is not affected by OSPF import policy actions.

The **no** form of this command removes all import policies from the configuration. The default behavior then applies, that is, if an OSPF route has the lowest preference value among all routes to the destination, it is installed in the routing table.

## Default

no import

## Parameters

*policy-name*

specifies the import route policy name. Allowed values are any string up to 32 characters long composed of printable, 7-bit ASCII characters. If the string contains special characters (such as #, \$, or spaces), the entire string must be enclosed within double quotes.

The route policy names must already be defined.

## loopfree-alternates

### Syntax

[no] loopfree-alternates

### Context

config>router>ospf

config>router>ospf3

### Description

This command enables loop-free alternate (LFA) computation by SPF under the OSPFv2 or OSPFv3 routing protocol context.

When this command is enabled, it instructs the IGP SPF to attempt to precalculate both a primary next hop and an LFA backup next hop for every learned prefix. When found, the LFA next hop is populated in the routing table along with the primary next hop for the prefix.

The **no** form of this command disables LFA computation by the IGP SPF.

### Default

no loopfree-alternates

## exclude

### Syntax

exclude

### Context

config>router>ospf>loopfree-alternates

config>router>ospf3>loopfree-alternates

### Description

This command enables the context for identifying prefix policies to be excluded from the LFA calculation by OSPF.

## prefix-policy

### Syntax

**prefix-policy** *prefix-policy* [*prefix-policy*...(up to 5 max)]

**no prefix-policy**

## Context

```
config>router>ospf>loopfree-alternates>exclude  
config>router>ospf3>loopfree-alternates>exclude
```

## Description

This command excludes from the LFA SPF calculation any prefixes that match a prefix entry in a prefix policy. If a prefix is excluded, it is not included in the LFA SPF calculation, regardless of its priority.

Prefix policies are created with the **config>router>policy-options>prefix-list** command. For information about prefix lists, see the 7705 SAR Router Configuration Guide, "Route Policies".

The default action of the **loopfree-alternates>exclude>prefix-policy** command, when not explicitly specified in the prefix policy, is to "reject". Therefore, even if the **default-action reject** statement was not explicitly stated for the prefix policy, a prefix that does not match any entry in the policy will be used in the LFA SPF calculation.

The **no** form of this command removes the excluded prefix policy.

## Default

no prefix-policy

## Parameters

*prefix-policy*

the name of the prefix policy to be excluded from the LFA SPF calculation for OSPF. Up to five prefixes can be specified. The specified prefix policy must already be defined.

## remote-lfa

### Syntax

```
remote-lfa [max-pq-cost value]
```

```
no remote-lfa
```

### Context

```
config>router>ospf>loopfree-alternates
```

### Description

This command enables the use of the remote LFA algorithm in the LFA SPF calculation in OSPF.

When this command is enabled, SPF performs the additional remote LFA computation that follows the regular LFA next-hop calculation when the latter calculation results in no protection for one or more prefixes that are resolved to a particular interface.

Remote LFA extends the protection coverage of LFA-FRR to any topology by automatically computing and establishing or tearing down shortcut tunnels, also referred to as repair tunnels, to a remote LFA node that puts the packets back into the shortest path without looping them back to the node that forwarded them over the repair tunnel. The remote LFA node is referred to as a PQ node. A repair tunnel can, in theory, be an RSVP-TE LSP, an LDP-in-LDP tunnel, or a segment routing (SR) tunnel. The **remote-lfa** command is restricted to using an SR repair tunnel to the remote LFA node.

The remote LFA algorithm is a per-link LFA SPF calculation and not a per-prefix calculation like the regular LFA algorithm. The remote LFA algorithm provides protection for all destination prefixes that share the protected link by using the neighbor on the other side of the protected link as a proxy for all the destinations.

The **no** form of this command disables the use of the remote LFA algorithm in the LFA SPF calculation in OSPF.

## Default

no remote-lfa

## Parameters

*value*

specifies the integer used to limit the search for candidate P and Q nodes in the remote LFA algorithm by setting the maximum IGP cost from the router performing the remote LFA calculation to the candidate P or Q node

**Values** 0 to 4294967295

**Default** 4261412864

## node-protect

### Syntax

**node-protect** [**max-pq-nodes** *value*]

**no node-protect**

### Context

config>router>ospf>loopfree-alternates>remote-lfa

config>router>ospf>loopfree-alternates>ti-lfa

### Description

This command administratively enables the use of the node-protect calculation in the remote LFA algorithm or topology-independent LFA (TI-LFA) algorithm in SPF computations. When node protection is enabled, the router prefers a node-protect repair tunnel over a link-protect repair tunnel for a particular prefix if both tunnels are found in the remote LFA or TI-LFA SPF computation. However, the SPF computations may only find a link-protect repair tunnel for prefixes owned by the protected node.

The **max-pq-nodes** parameter controls the maximum number of candidate PQ nodes found in the LFA SPFs for which the node protection check is performed. The node-protect condition means that the router must run the original link-protect remote LFA algorithm plus one extra forward SPF on behalf of each PQ node found, potentially after applying the **max-pq-cost** parameter, to verify that the path from the PQ node to the destination does not traverse the protected node. Setting the **max-pq-nodes** parameter to a lower value means that the LFA SPFs use less computation time and resources; however, this may result in not finding a node-protect repair tunnel.



**Note:** The optional **max-pq-nodes** parameter is available only in the **config>router>ospf>loopfree-alternates>remote-lfa** context.

The **no** form of the command disables the node-protect calculation.

## Default

no node-protect

## Parameters

*value*

specifies the maximum number of PQ nodes found in the LFA SPF for which the node protection check is performed

**Values** 1 to 32

**Default** 16

## ti-lfa

## Syntax

**ti-lfa** [**max-sr-frr-labels** *value*]

**no ti-lfa**

## Context

config>router>ospf>loopfree-alternates

## Description

This command enables the use of the topology-independent LFA (TI-LFA) algorithm in the LFA SPF calculation in OSPF.

The TI-LFA algorithm improves the protection coverage of a network topology by computing and automatically instantiating a repair tunnel to a Q node that is not in the shortest path from the computing node. The repair tunnel uses the shortest path to the P node and a source-routed path from the P node to the Q node.

The TI-LFA repair tunnel can have a maximum of three labels pushed in addition to the label of the destination node or prefix. The user can set a lower maximum value for the additional FRR labels by configuring the **max-sr-frr-labels** option.

The **no** form of this command disables the use of the TI-LFA algorithm in the LFA SPF calculation in OSPF.

## Default

no ti-lfa

## Parameters

*value*

specifies the maximum number of labels that the TI-LFA backup next hop can use. The TI-LFA algorithm uses this value to limit the search for the Q node from the P node on the post-convergence path.

**Values** 0 to 3

**Default** 2

## multicast-import

### Syntax

[no] multicast-import

### Context

config>router>ospf

config>router>ospf3

### Description

This command administratively enables the submission of routes into the multicast RTM by OSPF.

The **no** form of the command disables the submission of routes into the multicast RTM.

### Default

no multicast-import

## overload

### Syntax

overload [timeout *seconds*]

no overload

### Context

config>router>ospf

config>router>ospf3

### Description

This command changes the overload state of the local router so that it appears to be overloaded. When overload is enabled, the router can participate in OSPF routing, but is not used for transit traffic. Traffic destined for directly attached interfaces continues to reach the router.

To put the IGP in an overload state, enter a timeout value. The IGP will enter the overload state until the timeout timer expires or a **no overload** command is executed.

If no timeout is specified, the overload state is maintained indefinitely.

If the **overload** command is encountered during the execution of an **overload-on-boot** command, the **overload** command takes precedence. This situation could occur as a result of a saved configuration file where both parameters are saved. When the file is saved by the system, the **overload-on-boot** command is saved after the **overload** command.

Use the **no** form of this command to return to the default. When the **no overload** command is executed, the overload state is terminated regardless of the reason the protocol entered the overload state.

## Default

no overload

## Parameters

*seconds*

the number of seconds to reset overloading

**Values** 1 to 1800

## overload-include-stub

### Syntax

[no] **overload-include-stub**

### Context

config>router>ospf

config>router>ospf3

### Description

This command is used to determine if the OSPF stub networks should be advertised with a maximum metric value when the system goes into an overload state for any reason. When enabled, the system uses the maximum metric value. When this command is enabled and the router is in overload, all stub interfaces, including loopback and system interfaces, will be advertised at the maximum metric.

### Default

no overload-include-stub

## overload-on-boot

### Syntax

**overload-on-boot** [timeout *seconds*]

**no overload-on-boot**

## Context

```
config>router>ospf
config>router>ospf3
```

## Description

When the router is in an overload state, the router is used only if there is no other router to reach the destination. This command configures OSPF upon boot-up in the overload state until one of the following events occurs:

- the timeout timer expires (if a timeout has been specified)
- a manual override of the current overload state is entered with the **no overload** command

If no timeout is specified, the overload state is maintained indefinitely.

The **no overload** command does not affect the **overload-on-boot** function.

The **no** form of the command removes the **overload-on-boot** functionality from the configuration.

## Default

no overload-on-boot

## Parameters

*seconds*

the number of seconds to reset overloading

**Values** 1 to 1800

## preference

## Syntax

**preference** *preference*

**no preference**

## Context

```
config>router>ospf
config>router>ospf3
```

## Description

This command configures the preference for OSPF internal routes.

A route can be learned by the router from different protocols, in which case, the costs are not comparable. When this occurs, the preference is used to decide which route will be used.

Different protocols should not be configured with the same preference. If this occurs, the tiebreaker is based on the default preferences as defined in [Table 38: Route preference defaults by route type](#) . If multiple routes are learned with the same preference using the same protocol and the costs (metrics) are equal, the decision of which route to use is determined by the configuration of ECMP in the **config>router** context. See the 7705 SAR Router Configuration Guide for information about ECMP.



The **no** form of the command reverts to the default value.

### Default

preference 10 – OSPF internal routes have a preference of 10

### Parameters

*preference*

the preference for internal routes, expressed as a decimal integer

**Values** 1 to 255

## reference-bandwidth

### Syntax

**reference-bandwidth** *bandwidth-in-kbps*

**reference-bandwidth** [**tbps** *Tera-bps*] [**gbps** *Giga-bps*] [**mbps** *Mega-bps*] [**kbps** *Kilo-bps*]

**no reference-bandwidth**

### Context

config>router>ospf

config>router>ospf3

### Description

This command configures the reference bandwidth used to calculate the default costs of interfaces based on their underlying link speed.

The default interface cost is calculated as follows:

cost = reference bandwidth/bandwidth

The default reference bandwidth is 100 000 000 kb/s or 100 Gb/s; therefore, the default auto-cost metrics for various link speeds are as follows:

- 10 Mb/s link: default cost of 10000
- 100 Mb/s link: default cost of 1000
- 1 Gb/s link: default cost of 100
- 10 Gb/s link: default cost of 10

The **reference-bandwidth** command assigns a default cost to the interface based on the interface speed. To override this default cost on a particular interface, use the **metric** *metric* command in the **config>router>ospf>area>interface** *ip-int-name* or **config>router> ospf3>area>interface** *ip-int-name* context.

The **no** form of the command resets the reference bandwidth to the default value.

### Default

reference-bandwidth 100000000

## Parameters

### *bandwidth-in-kbps*

the reference bandwidth in kilobits per second, expressed as a decimal integer

**Values** 1 to 4000000000

### *Tera-bps*

the reference bandwidth in terabits per second, expressed as a decimal integer

**Values** 1 to 4

### *Giga-bps*

the reference bandwidth in gigabits per second, expressed as a decimal integer

**Values** 1 to 999

### *Mega-bps*

the reference bandwidth in megabits per second, expressed as a decimal integer

**Values** 1 to 999

### *Kilo-bps*

the reference bandwidth in kilobits per second, expressed as a decimal integer

**Values** 1 to 999

## router-id

### Syntax

**router-id** *ip-address*

**no router-id**

### Context

config>router>ospf

config>router>ospf3

### Description

This command configures the router ID to be used under the global routing table context (GRT). The 7705 SAR supports a single OSPF instance in the GRT context; therefore, changing the router ID has a global implication.

When configuring the router ID in the base instance of OSPF, the value overrides the router ID configured in the **config>router** context.

The default value for the base instance is inherited from the configuration in the **config>router** context. If the router ID in the **config>router** context is not configured, the following applies:

- the system uses the system interface address (which is also the loopback address)
- if a system interface address is not configured, the last 4 bytes of the chassis MAC address are used

When configuring a new router ID, the instance is not automatically restarted with the new router ID. The next time the instance is initialized, the new router ID is used.

To force the new router ID to be used, issue the **shutdown** and **no shutdown** commands for the instance, or reboot the entire router.

The **no** form of the command reverts to the default value.

## Default

0.0.0.0 (base OSPF)

## Parameters

*ip-address*

a 32-bit, unsigned integer uniquely identifying the router in the autonomous system

## rsvp-shortcut

### Syntax

[no] **rsvp-shortcut**

### Context

config>router>ospf

### Description

This command enables the use of an RSVP-TE shortcut for resolving OSPF routes. When the command is enabled, OSPF includes RSVP-TE LSPs originating on this node and terminating on the router ID of a remote node as direct links with a metric equal to the operational metric provided by MPLS.

The SPF algorithm will always use the IGP metric to build the SPF tree, and the LSP metric value does not update the SPF tree calculation. During the IP reach to determine the reachability of nodes and prefixes, LSPs are overlaid and the LSP metric is used to determine the subset of paths that are of an equal lowest cost to reach a node or a prefix. If the **relative-metric** option for this LSP is enabled (in the **config>router>mpls>lsp>igp-shortcut** context), OSPF will apply the shortest cost between the endpoints of the LSP plus the value of the offset, instead of the LSP operational metric, when calculating the cost of a prefix that is resolved to the LSP.

When a prefix is resolved to a tunnel next hop, the packet is sent labeled with the label stack corresponding to the NHLFE of the RSVP-TE LSP. Any network event that causes an RSVP-TE LSP to go down will trigger a full SPF calculation, which may result in a new route being installed over another RSVP-TE LSP shortcut as a tunnel next hop or over a regular IP next hop.

When the **rsvp-shortcut** command is enabled, all RSVP-TE LSPs originating on this node are eligible by default as long as the destination address of the LSP, as configured with the **config>router>mpls>lsp>to** command, corresponds to a router ID of a remote node. A specific LSP can be excluded from being used as a shortcut with the **config>router>mpls>lsp>no igp-shortcut** command.

If ECMP is enabled on the system and multiple equal-cost paths exist for the route over a set of tunnel next hops (based on the hashing routine supported for IPv4 packets), there are two possibilities:

- if the destination is the tunnel endpoint, the system selects the tunnel with the lowest tunnel ID (the IP next hop is never used)

- if the destination is different from the tunnel endpoint, the system:
  - selects tunnel endpoints where the LSP metric is lower than the IGP cost
  - prefers tunnel endpoints over IP next hops

ECMP is not performed across both the IP and tunnel next hops.

OSPF can populate the multicast RTM with the prefix IP next hop when both **rsvp-shortcut** and **node-protect** are enabled. The unicast RTM can still use the tunnel next hop for the same prefix.

The forwarding adjacency feature (**advertise-tunnel-link**) can be enabled independently from the shortcuts feature. If both features are enabled in OSPF, the forwarding adjacency feature takes precedence.

The **no** form of this command disables the resolution of IGP routes using RSVP shortcuts.

## Default

no rsvp-shortcut

## segment-routing

## Syntax

**[no] segment-routing**

## Context

config>router>ospf

## Description

This command enables the context to configure segment routing parameters within an IGP instance.

Segment routing adds to IS-IS and OSPF routing protocols the ability to perform shortest path routing and source routing using the concept of abstract segment. An abstract segment can represent a local prefix of a node, a specific adjacency of the node (interface or next hop), a service context, or a specific explicit path over the network. For each segment, the IGP advertises an identifier referred to as a segment ID (SID).



**Note:** Segment routing is supported only in OSPFv2 for IPv4.

When segment routing is used together with the MPLS data plane, the SID is a standard MPLS label. A router forwarding a packet using segment routing will push one or more MPLS labels.

Segment routing using MPLS labels can be used in both shortest path routing applications and traffic engineering applications. On the 7705 SAR, segment routing implements the shortest path forwarding application.

After segment routing is successfully enabled in the IS-IS instance or in OSPF, the router will perform the following operations:

- advertise the Segment Routing Capability sub-TLV to routers in all areas or levels of the IGP instance. However, only neighbors with which the IGP instance established an adjacency will interpret the SID and label range information and use it for calculating the label to swap to or push for a particular resolved prefix SID.

- advertise the assigned index for each configured node SID in the new prefix SID sub-TLV with the N-flag (node SID flag) set. The segment routing module then programs the incoming label map (ILM) with a pop operation for each local node SID in the data path.
- automatically assign and advertise an adjacency SID label for each formed adjacency over a network IP interface in the new adjacency SID sub-TLV. The segment routing module programs the incoming label map (ILM) with a pop operation, in effect with a swap to an implicit null label operation, for each advertised adjacency SID.
- resolve received prefixes, and if a prefix SID sub-TLV exists, the segment routing module programs the ILM with a swap operation and programs an LSP ID to NHLFE (LTN) with a push operation, both pointing to the primary/LFA NHLFE. An SR tunnel is also added to the TTM.

When the user enables segment routing in an IGP instance, the main SPF and LFA SPF are computed normally and the primary next hop and LFA backup next hop for a received prefix are added to the RTM without the label information advertised in the prefix SID sub-TLV.

## adj-sid-hold

### Syntax

**adj-sid-hold** *seconds*

**no adj-sid-hold**

### Context

config>router>ospf>segment-routing

### Description

This command configures a timer to hold the ILM or LTN of an adjacency SID following a failure of the adjacency.

When an adjacency to a neighbor fails, the IGP will withdraw the advertisement of the link TLV information as well as its adjacency SID sub-TLV. However, the LTN or ILM record of the adjacency SID must be kept in the data path to maintain forwarding using the LFA or remote LFA backup for sufficient length of time to allow the ingress LER and other routers that use this adjacency SID to activate a new path after the IGP converges.

If the adjacency is restored before the timer expires, the timer is aborted as soon as the new ILM or LTN records are updated with the new primary and backup NHLFE information.

The **no** form of the command removes the adjacency SID hold time.

### Default

adj-sid-hold 15

### Parameters

*seconds*

the adjacency SID hold time, in seconds

**Values** 1 to 300

## backup-node-sid

### Syntax

**backup-node-sid** *ip-prefix/prefix-length* **index** [0..4294967295]

**backup-node-sid** *ip-prefix/prefix-length* **label** [1..4294967295]

**no backup-node-sid**

### Context

config>router>ospf>segment-routing

### Description

This command enables LFA protection using a segment routing backup node SID.

The objective of this feature is to reduce the label stack pushed in an LFA tunnel next hop of inter-area and inter-domain prefixes. This is applicable in MPLS deployments across multiple IGP areas or domains such as in seamless MPLS design.

The user enables the feature by configuring a backup node SID at an ABR/ASBR that is acting as a backup to the primary exit ABR/ASBR of inter-area or inter-as routes learned as BGP labeled routes. The user can enter either a label or an index for the backup node SID.

When a node in an IGP domain resolves a BGP label route for an inter-area or inter-domain prefix via the primary ABR exit router, the node will use the backup node SID of the primary ABR exit router, which is advertised by the backup ABR/ASBR, as the LFA backup—instead of the SID to the remote LFA PQ node—to save on the pushed label stack.

This feature only allows the configuration of a single backup node SID per IGP instance and per ABR/ASBR. In other words, only a pair of ABR/ASBR nodes can back up each other in an IGP domain. Each time the user invokes the **backup-node-sid** command within the same IGP instance, it overrides any previous configuration of the backup node SID. The same ABR/ASBR can, however, participate in multiple IGP instances and provide backup support within each instance.

### Default

no backup-node-sid

### Parameters

*ip-prefix/ip-prefix-length*

the IPv4 or IPv6 address prefix

*index*

specifies the index for this backup node SID

**Values** 0 to 4294967295

*label*

specifies the SID value for this backup node SID

**Values** 1 to 4294967295

## entropy-label

### Syntax

**entropy-label** {**force-disable** | **enable**}

**no entropy-label**

### Context

config>router>ospf>segment-routing

### Description

This command, when used with the **force-disable** keyword, instructs the system to ignore any received IGP advertisements of entropy label capability relating to remote nodes in the network. The command also prevents a user from configuring **override-tunnel-elic** for the IGP instance.

The **no** version of this command enables the processing of any received IGP advertisements of entropy label capability. Using the **enable** keyword has the same effect.

### Default

entropy-label enable

### Parameters

#### **force-disable**

forces the system to ignore any received advertisements of entropy label capability signaled in the IGP

#### **enable**

enables the system to process any received advertisements of entropy label capability signaled in the IGP

## prefix-sid-range

### Syntax

**prefix-sid-range global**

**prefix-sid-range start-label** *label-value* **max-index** *index-value*

**no prefix-sid-range**

### Context

config>router>ospf>segment-routing

### Description

This command configures the prefix SID index range and offset label value for an IGP instance.

The key parameter is the configuration of the prefix SID index range and the offset label value that this IGP instance will use. Because each prefix SID represents a network global IP address, the SID index for a

prefix must be unique network-wide. Therefore, all routers in the network are expected to configure and advertise the same prefix SID index range for an IGP instance. However, the label value used by each router to represent this prefix, that is, the label programmed in the ILM, can be local to that router by the use of an offset label, referred to as a start label:

*Local Label (Prefix SID) = start-label + {SID index}*

The label operation in the network is very similar to LDP when operating in independent label distribution mode (RFC 5036, *LDP Specification*), with the difference being that the label value used to forward a packet to each downstream router is computed by the upstream router based on the advertised prefix SID index using the above formula.

There are two mutually exclusive modes of operation for the prefix SID range on the router: **global** mode and per-instance mode.

In global mode, the user configures the **global** keyword and the IGP instance assumes that the start label value is the lowest label value in the SRGB and the prefix SID index range size is equal to the range size of the SRGB. When one IGP instance selects the **global** option for the prefix SID range, all IGP instances on the system must do the same. The user must shut down the segment routing context and disable the **prefix-sid-range** command in all IGP instances in order to change the SRGB. When the SRGB is changed, the user must re-enable the **prefix-sid-range** command. The SRGB range change will fail if an already allocated SID index/label goes out of range.

In per-instance mode, the user partitions the SRGB into non-overlapping sub-ranges among the IGP instances. The user configures a subset of the SRGB by specifying the start label value and the prefix SID index range size. All resulting net label values (start-label + index) must be within the SRGB or the configuration will fail. The 7705 SAR checks for overlaps of the resulting net label value range across IGP instances and will strictly enforce no overlapping of these ranges. The user must shut down the segment routing context of an IGP instance in order to change the SID index/label range of that IGP instance using the **prefix-sid-range** command. A range change will fail if an already allocated SID index/label goes out of range. The user can change the SRGB without shutting down the segment routing context as long as it does not reduce the current per-IGP instance SID index/label range defined with the **prefix-sid-range** command. Otherwise, shut down the segment routing context of the IGP instance, and disable and re-enable the **prefix-sid-range** command.

## Default

no prefix-sid-range

## Parameters

*label-value*

specifies the label offset for the SR label range of this IGP instance

**Values** 0 to 524287

*index-value*

specifies the maximum value of the prefix SID index range for this IGP instance

**Values** 1 to 524287



## srlb

### Syntax

**srlb** *reserved-label-block-name*

**no srlb**

### Context

config>router>ospf>segment-routing

### Description

This command specifies the reserved label block to use for the segment routing local block (SRLB) for this OSPF instance. The reserved label block must first be configured in the **config>router>mpls-labels** context.

The **no** form of the command removes the SRLB.

### Default

no srlb

### Parameters

*reserved-label-block-name*

the name of the reserved label block

## tunnel-mtu

### Syntax

**tunnel-mtu** *bytes*

**no tunnel-mtu**

### Context

config>router>ospf>segment-routing

### Description

This command configures the MTU of all SR tunnels within each IGP instance.

The MTU of an SR tunnel populated into the TTM is determined in the same way as the MTU of an IGP tunnel (for example, for an LDP LSP), based on the outgoing interface MTU minus the label stack size. Remote LFA can add, at most, one more label to the tunnel for a total of two labels. There is no default value for this command. If the user does not configure an SR tunnel MTU, the MTU, in bytes, is determined by IGP as explained below.

$SR\_Tunnel\_MTU = MIN \{Cfg\_SR\_MTU, IGP\_Tunnel\_MTU - (1 + fr\_overhead) * 4\}$

where:

- *Cfg\_SR\_MTU* is the MTU configured by the user for all SR tunnels within an IGP instance using the above CLI. If no value was configured by the user, the SR tunnel MTU will be fully determined by the IGP interface calculation explained next.
- *IGP\_Tunnel\_MTU* is the minimum of the IS-IS or OSPF interface MTU among all the ECMP paths or among the primary and LFA backup paths of this SR tunnel.
- *frr-overhead* is set to 1 if **segment-routing** and **remote-lfa** options are enabled in the IGMP instance. Otherwise, it is set to 0.

The SR tunnel MTU is dynamically updated anytime any of the above parameters used in its calculation changes. This includes when the set of the tunnel next hops changes or the user changes the configured SR MTU or interface MTU value.

## Default

no tunnel-mtu

## Parameters

*bytes*

specifies the size of the MTU in bytes

**Values** 512 to 9198

**Default** none

## tunnel-table-pref

## Syntax

**tunnel-table-pref** *preference*

**no tunnel-table-pref**

## Context

config>router>ospf>segment-routing

## Description

This command configures the TTM preference of shortest path SR tunnels created by the IGP instance. This is used for BGP shortcuts, VPRN autobind, or BGP transport tunnel when the tunnel binding commands are configured to the **any** value, which parses the TTM for tunnels in the protocol preference order. The user can choose to either accept the global TTM preference or explicitly list the tunnel types they want to use. If the user lists the tunnel types explicitly, the TTM preference is still used to select one type over the other. In both cases, a fallback to the next preferred tunnel type is performed if the selected type fails. A reversion to a more preferred tunnel type is performed as soon as one is available.

The segment routing module adds to the TTM an SR tunnel entry for each resolved remote node SID prefix and programs the data path having the corresponding LTN with the push operation pointing to the primary and LFA backup NHLFEs.

The default preference for shortest path SR tunnels in the TTM is set lower than LDP tunnels but higher than BGP tunnels to allow controlled migration of customers without disrupting their current deployment

when they enable segment routing. The following is the value of the default preference for the various tunnel types. This includes the preference of SR tunnels based on shortest path (referred to as SR-ISIS and SR-OSPF).



**Note:** The preference of SR-TE LSP is not configurable and is the second most preferred tunnel type after RSVP-TE. This is independent if the SR-TE LSP was resolved in IS-IS or OSPF.

The global default TTM preference for the tunnel types is as follows:

ROUTE_PREF_RSVP	7
ROUTE_PREF_SR_TE	8
ROUTE_PREF_LDP	9
ROUTE_PREF_SR_OSPF_TTM	10
ROUTE_PREF_SR_ISIS_TTM	11
ROUTE_PREF_BGP_TTM	12
ROUTE_PREF_GRE	255

The default value for SR-ISIS is the same regardless of whether one or more IS-IS instances programmed a tunnel for the same prefix. The selection of an SR tunnel in this case is based on the lowest IGP instance ID.

## Default

tunnel-table-pref 10

## Parameters

*preference*

specifies the integer value to represent the preference of OSPF SR tunnels in the TTM

**Values** 1 to 255

## timers

## Syntax

**timers**

## Context

config>router>ospf

config>router>ospf3

## Description

This command enables the context that allows for the configuration of OSPF timers. Timers control the delay between receipt of a link-state advertisement (LSA) requiring an SPF calculation and the minimum time between successive SPF calculations.

Changing the timers affects CPU usage and network reconvergence times. Lower values reduce reconvergence time but increase CPU usage. Higher values reduce CPU usage but increase reconvergence time.

### Default

n/a

## lsa-arrival

### Syntax

**lsa-arrival** *lsa-arrival-time*

**no lsa-arrival**

### Context

config>router>ospf>timers

config>router>ospf3>timers

### Description

This command defines the minimum delay that must pass between receipt of the same link-state advertisements (LSAs) arriving from neighbors.

It is recommended that the configured **lsa-generate** *lsa-second-wait* interval for the neighbors be equal to or greater than the *lsa-arrival-time*.



**Note:** The OSPF timer granularity is 10 ms if the value is less than 500 ms, and 100 ms if the value is equal to 500 ms. Timer values are rounded down to the nearest granularity; for example, a configured value of 550 ms is internally rounded down to 500 ms.

Use the **no** form of this command to return to the default.

### Default

no lsa-arrival

### Parameters

*lsa-arrival-time*

the timer in milliseconds. Values entered that do not match this requirement will be rejected.

**Values** 0 to 600000

## lsa-generate

### Syntax

**lsa-generate** *max-lsa-wait* [*lsa-initial-wait* [*lsa-second-wait*]]

**no lsa-generate****Context**

```
config>router>ospf>timers
config>router>ospf3>timers
```

**Description**

This command customizes the throttling of OSPF LSA generation. Timers that determine when to generate the first, second, and subsequent LSAs can be controlled with this command. Subsequent LSAs are generated at increasing intervals of the *lsa-second-wait* timer until a maximum value is reached.

It is recommended that the *lsa-arrival-time* be equal to or less than the *lsa-second-wait* interval.



**Note:** The OSPF timer granularity is 10 ms if the value is less than 500 ms, and 100 ms if the value is equal to 500 ms. Timer values are rounded down to the nearest granularity; for example, a configured value of 550 ms is internally rounded down to 500 ms.

Use the **no** form of this command to return to the default.

**Default**

```
no lsa-generate
```

**Parameters***max-lsa-wait*

the maximum interval, in milliseconds, between two consecutive occurrences of an LSA being generated

**Values** 10 to 600000

**Default** 5000

*lsa-initial-wait*

the first waiting period between LSAs generated, in milliseconds. When the LSA exceeds the *lsa-initial-wait* timer value and the topology changes, there is no wait period and the LSA is immediately generated.

When an LSA is generated, the initial wait period commences. If, within the specified *lsa-initial-wait* period, another topology change occurs, the *lsa-initial-wait* timer applies.

**Values** 10 to 600000

**Default** 5000

*lsa-second-wait*

the hold time, in milliseconds, between the first and second LSA generation. The next topology change is subject to this second wait period. With each subsequent topology change, the wait time doubles (that is, two times the previous wait time). This assumes that each failure occurs within the relevant wait period.

**Values** 10 to 600000

**Default** 5000

## spf-wait

### Syntax

**spf-wait** *max-spf-wait* [**spf-initial-wait** *spf-initial-wait*] [**spf-second-wait** *spf-second-wait*]

**no spf-wait**

### Context

config>router>ospf>timers

config>router>ospf3>timers

### Description

This command defines the maximum interval between two consecutive SPF calculations in milliseconds. Timers that determine when to initiate the first, second, and subsequent SPF calculations after a topology change occurs can be controlled with this command. Subsequent SPF runs (if required) will occur at exponentially increasing intervals of the *spf-second-wait* interval. For example, if the *spf-second-wait* interval is 1000, the next SPF will run after 2000 ms, and the next SPF will run after 4000 ms, and so on, until it reaches the **spf-wait** value. The SPF interval will stay at the **spf-wait** value until there are no more SPF runs scheduled in that interval. After a full interval without any SPF runs, the SPF interval will drop back to *spf-initial-wait*.



**Note:** The OSPF timer granularity is 10 ms if the value is less than 500 ms, and 100 ms if the value is equal to 500 ms. Timer values are rounded down to the nearest granularity; for example, a configured value of 550 ms is internally rounded down to 500 ms.

Use the **no** form of this command to return to the default.

### Default

no spf-wait

### Parameters

*max-spf-wait*

the maximum interval, in milliseconds, between two consecutive SPF calculations

**Values** 10 to 120000

**Default** 1000

*spf-initial-wait*

the initial SPF calculation delay, in milliseconds, after a topology change

**Values** 10 to 100000

**Default** 1000

*spf-second-wait*

the hold time, in milliseconds, between the first and second SPF calculation

**Values** 10 to 100000

**Default** 1000

**traffic-engineering****Syntax**

[no] **traffic-engineering**

**Context**

config>router>ospf

**Description**

This command enables traffic engineering route calculations constrained by nodes or links.

Traffic engineering enables the router to perform route calculations constrained by nodes or links. The traffic engineering capabilities of this router are limited to calculations based on link and nodal constraints.

The **no** form of the command disables traffic engineered route calculations.

**Default**

no traffic-engineering

**unicast-import-disable****Syntax**

[no] **unicast-import-disable**

**Context**

config>router>ospf

config>router>ospf3

**Description**

This command allows one IGP to import its routes into the multicast RTM (also known as the RPF RTM [Reverse Path Forwarding - Route Table Manager]) while another IGP imports routes only into the unicast RTM. Import policies can redistribute routes from an IGP protocol into the RPF RTM. By default, the IGP routes will not be imported into the RPF RTM, since such an import policy must be explicitly configured.

The **no** form of the command enables importing IGP routes into the RPF RTM.

**Default**

disabled (unicast-import-disable)

### 4.14.2.1.3 Area commands

#### area

##### Syntax

```
[no] area area-id
```

##### Context

```
config>router>ospf
```

```
config>router>ospf3
```

##### Description

This command enables the context to configure an OSPF area. An area is a collection of network segments within an AS that have been administratively grouped together. The area ID can be specified in dotted-decimal notation or as a 32-bit decimal integer.

The **no** form of the command deletes the specified area from the configuration. Deleting the area also removes the OSPF configuration of all the interfaces, virtual links, address ranges, and so on, that are currently assigned to this area.

The 7705 SAR supports a maximum of four areas.

##### Default

no area – no OSPF areas are defined

##### Parameters

*area-id*

the OSPF area ID expressed in dotted-decimal notation or as a 32-bit decimal integer

<b>Values</b>	0.0.0.0 to 255.255.255.255 (dotted-decimal) 0 to 4294967295 (decimal integer)
---------------	---

#### advertise-router-capability

##### Syntax

```
[no] advertise-router-capability
```

##### Context

```
config>router>ospf>area
```

```
config>router>ospf>area>interface
```

```
config>router>ospf3>area
```

```
config>router>ospf3>area>interface
```



## Description

This command enables advertisement of a router's capabilities to its neighbors for informational and troubleshooting purposes. A Router Information (RI) LSA as defined in RFC 4970 advertises the following capabilities:

- OSPF graceful restart capable: no
- OSPF graceful restart helper: yes, when enabled
- OSPF stub router support: yes
- OSPF traffic engineering support: yes, when enabled
- OSPF point-to-point over LAN: yes
- OSPF experimental TE: no

The **no** form of this command disables this capability.

## Default

advertise-router-capability

## area-range

### Syntax

**area-range** *ip-prefix/mask* [**advertise** | **not-advertise**]

**no area-range** *ip-prefix/mask*

**area-range** *ipv6-prefix/prefix-length* [**advertise** | **not-advertise**]

**no area-range** *ipv6-prefix/prefix-length*

### Context

config>router>ospf>area

config>router>ospf>area>nssa

config>router>ospf3>area

config>router>ospf3>area>nssa

## Description

This command creates ranges of addresses on an Area Border Router (ABR) for the purpose of route summarization or suppression. When a range is created, the range is configured to be advertised or not advertised to other areas. Multiple range commands can be used to summarize or hide different ranges. In the case of overlapping ranges, the most specific range command applies.

ABRs send summary link advertisements to describe routes to other areas. To minimize the number of advertisements that are flooded, you can summarize a range of IP addresses and send reachability information about these addresses in an LSA.

The *ip-prefix/mask* parameter applies in the **ospf** context. The *ipv6-prefix/prefix-length* parameter applies in the **ospf3** context.

The **no** form of the command deletes the range advertisement or non-advertisement.

**Default**

no area-range – no range of addresses is defined

**Special cases****NSSA context**

in the NSSA context, the option specifies that the range applies to external routes (via type 7 LSAs) learned within the NSSA when the routes are advertised to other areas as type 5 LSAs

**Area context**

if this command is not entered under the NSSA context, the range applies to summary LSAs even if the area is an NSSA

**Parameters**

*ip-prefix/mask*

the IPv4 prefix for the range in dotted-decimal notation and the subnet mask for the range, expressed as a decimal integer

*ipv6-prefix/prefix-length*

the IPv6 prefix for the range in hexadecimal notation

**advertise | not-advertise**

specifies whether to advertise the summarized range of addresses to other areas

**Default** advertise

**blackhole-aggregate****Syntax**

**[no] blackhole-aggregate**

**Context**

config>router>ospf>area

config>router>ospf3>area

**Description**

This command installs a low-priority blackhole route for the entire aggregate. Existing routes that make up the aggregate will have a higher priority and only the components of the range for which no route exists will be blackholed.

When performing area aggregation, addresses may be included in the range for which no actual route exists. This can cause routing loops. To avoid this problem, configure the blackhole aggregate option.

The **no** form of this command removes this option.

**Default**

blackhole-aggregate

## key-rollover-interval

### Syntax

**key-rollover-interval** *seconds*

**no key-rollover-interval**

### Context

config>router>ospf3>area

### Description

This command configures the key rollover interval. The **no** form of the command resets the configured interval to the default setting.

### Default

10

### Parameters

*key-rollover-interval*

specifies the time, in seconds, after which a key rollover will start

**Values** 10 to 300

## loopfree-alternate-exclude

### Syntax

**[no] loopfree-alternate-exclude**

### Context

config>router>ospf>area

config>router>ospf3>area

config>router>ospf>area>interface

config>router>ospf3>area>interface

### Description

This command instructs OSPF to exclude a specific interface or all interfaces participating in a specific OSPF area from the LFA SPF calculation. The LFA SPF calculation can therefore be run only where it is needed.

If an interface is excluded from the LFA SPF calculation, it is excluded in all areas. However, this command can only be executed under the area in which the specified interface is primary. When the command is executed, the interface is excluded in that area and in all other areas where the interface is secondary. If the user attempts to execute the command under an area where the interface is secondary, the command will fail.

## Default

no loopfree-alternate-exclude

## nssa

## Syntax

[no] nssa

## Context

config>router>ospf>area

config>router>ospf3>area

## Description

This command enables the context to configure an OSPF Not So Stubby Area (NSSA) and adds or removes the NSSA designation from the area.

NSSAs are similar to stub areas in that no external routes are imported into the area from other OSPF areas. The major difference between a stub area and an NSSA is that an NSSA has the capability to flood external routes that it learns throughout its area and via an ABR to the entire OSPF domain.

Existing virtual links of a stub area or NSSA are removed when the designation is changed to NSSA or stub.

An area can be designated as stub or NSSA but never both at the same time.

By default, an area is not configured as an NSSA area.

The **no** form of the command removes the NSSA designation and configuration context from the area.

## Default

no nssa

## originate-default-route

## Syntax

originate-default-route [type-7] [no-adjacency-check]

originate-default-route [type-nssa] [no-adjacency-check]

no originate-default-route

## Context

config>router>ospf>area>nssa

config>router>ospf3>area>nssa

## Description

This command enables the generation of a default route and its LSA type into an NSSA by an NSSA ABR or ASBR.

The functionality of the **type-7** parameter and the **type-nssa** parameter is the same. The **type-7** parameter is available in the **ospf** context; the **type-nssa** parameter is available in the **ospf3** context. Include the **type-7** or **type-nssa** parameter to inject a type 7 LSA default route instead of the type 3 LSA into the NSSA configured with no summaries.

To revert to a type 3 LSA, enter the **originate-default-route** command without the **type-7** or **type-nssa** parameter.

When configuring an NSSA with no summaries, the ABR will inject a type 3 LSA default route into the NSSA area. Some older implementations expect a type 7 LSA default route.

The **no** form of the command disables origination of a default route.

## Default

no originate-default-route

## Parameters

### **type-7** | **type-nssa**

specifies that a type 7 LSA should be used for the default route

### **no-adjacency-check**

specifies whether adjacency checks are performed before originating a default route. If this parameter is configured, no area 0 adjacency is required for the ABR to advertise the default route.

## redistribute-external

## Syntax

[no] redistribute-external

## Context

config>router>ospf>area>nssa

config>router>ospf3>area>nssa

## Description

This command enables the redistribution of external routes into the Not So Stubby Area (NSSA) on an NSSA area border router (ABR) that is exporting the routes into non-NSSA areas.

NSSAs are similar to stub areas in that no external routes are imported into the area from other OSPF areas. The major difference between a stub area and an NSSA is that the NSSA has the capability to flood external routes that it learns (providing it is an ASBR) throughout its area and via an ABR to the entire OSPF domain.

The **no** form of the command disables the default behavior to automatically redistribute external routes into the NSSA area from the NSSA ABR.

## Default

redistribute-external

## summaries

### Syntax

[no] summaries

### Context

```
config>router>ospf>area>nssa
config>router>ospf>area>stub
config>router>ospf3>area>nssa
config>router>ospf3>area>stub
```

### Description

This command enables sending summary (type 3) advertisements into a stub area or NSSA on an ABR.

This parameter is particularly useful to reduce the size of the routing and link-state database (LSDB) tables within the stub or NSSA area.

By default, summary route advertisements are sent into the stub area or NSSA.

The **no** form of the command disables sending summary route advertisements and, for stub areas, only the default route is advertised by the ABR.

### Default

summaries

## stub

### Syntax

[no] stub

### Context

```
config>router>ospf>area
config>router>ospf3>area
```

### Description

This command enables access to the context to configure an OSPF stub area and adds or removes the stub designation from the area.

External routing information is not flooded into stub areas. All routers in the stub area must be configured with the **stub** command.

Existing virtual links of a stub area or NSSA are removed when its designation is changed to NSSA or stub.

An OSPF area cannot be both an NSSA and a stub area at the same time.

By default, an area is not a stub area.

The **no** form of the command removes the stub designation and configuration context from the area.

### Default

no stub

## default-metric

### Syntax

**default-metric** *metric*

**no default-metric**

### Context

config>router>ospf>area>stub

config>router>ospf3>area>stub

### Description

This command configures the metric used by the ABR for the default route into a stub area.

The default metric should only be configured on an ABR of a stub area.

An ABR generates a default route if the area is a **stub** area.

The **no** form of the command reverts to the default value.

### Default

default-metric 1

### Parameters

*metric*

the metric, expressed as a decimal integer, for the default route cost to be advertised into the stub area

**Values** 1 to 65535

## 4.14.2.1.4 Interface/virtual link commands

## interface

### Syntax

**interface** *ip-int-name* [**secondary**]

**no interface** *ip-int-name*

## Context

```
config>router>ospf>area  
config>router>ospf3>area
```

## Description

This command creates a context to configure an OSPF interface.

By default, interfaces are not activated in any interior gateway protocol, such as OSPF, unless explicitly configured.

The **no** form of the command deletes the OSPF interface configuration for this interface. The **shutdown** command in the **config>router>ospf>area>interface** context can be used to disable an interface without removing the configuration for the interface.

## Default

```
no interface
```

## Parameters

*ip-int-name*

the IP interface name. Interface names must be unique within the group of defined IP interfaces for the **config>router>interface** command. An interface name cannot be in the form of an IP address. Interface names can be any string up to 32 characters long composed of printable, 7-bit ASCII characters. If the string contains special characters (such as #, \$, or spaces), the entire string must be enclosed within double quotes.

If the IP interface exists in a different area, the configuration will be rejected with an error message unless the keyword **secondary** is specified.

**secondary**

enables multiple secondary adjacencies to be established over this IP interface

## adjacency-sid

## Syntax

```
adjacency-sid label value  
no adjacency-sid
```

## Context

```
config>router>ospf>area>interface
```

## Description

This command assigns a static value to an adjacency SID in OSPF segment routing.

The **no** form of the command removes the adjacency SID.

## Default

```
no adjacency-sid
```



## Parameters

*value*

the static value of the adjacency SID

**Values** 1 to 1048575, within the segment routing local block (SRLB) range

## advertise-subnet

### Syntax

[no] advertise-subnet

### Context

config>router>ospf>area>interface

### Description

This command enables advertising point-to-point interfaces as subnet routes (network number and mask). When disabled, point-to-point interfaces are advertised as host routes.

The **no** form of the command disables advertising point-to-point interfaces as subnet routes, meaning they are advertised as host routes.

### Default

advertise-subnet

## auth-keychain

### Syntax

auth-keychain *name*

no auth-keychain

### Context

config>router>ospf>area>interface

config>router>ospf>area>virtual-link

### Description

This command associates an authentication key chain with the OSPF interface or virtual link. The keychain is a collection of keys used to authenticate OSPF messages from remote peers. The key chain allows the rollover of authentication keys during the lifetime of a session and also supports stronger authentication algorithms than clear text and MD5.

The key chain must already be defined in the **config>system>security>keychain** context.

Either the **authentication-key** command or the **auth-keychain** command can be used by OSPF, but both cannot be supported at the same time. If both commands are configured, the **auth-keychain** configuration will be applied and the **authentication-key** command will be ignored.

By default, authentication is not enabled.

### Default

no auth-keychain

### Parameters

*name*

the name of an existing key chain, up to 32 characters

## authentication

### Syntax

**authentication bidirectional** *sa-name*

**authentication inbound** *sa-name* **outbound** *sa-name*

**no authentication**

### Context

config>router>ospf3>area>interface

config>router>ospf3>area>virtual-link

### Description

This command configures an interface with a static security association (SA) used to authenticate OSPFv3 packets.

The **no** form of the command removes the SA name from the configuration.

### Parameters

**bidirectional** *sa-name*

specifies the IPsec SA name used for transmitting and receiving OSPFv3 packets

**inbound** *sa-name*

specifies the IPsec SA name used for receiving OSPFv3 packets

**outbound** *sa-name*

specifies the IPsec SA name used for transmitting OSPFv3 packets

## authentication-key

### Syntax

**authentication-key** {*authentication-key* | *hash-key*} [**hash** | **hash2**]

**no authentication-key**

## Context

```
config>router>ospf>area>interface  
config>router>ospf>area>virtual-link
```

## Description

This command configures the password used by the OSPF interface or virtual link to send and receive OSPF protocol packets on the interface when simple password authentication is configured.

All neighboring routers must use the same type of authentication and password for correct protocol communication. If the **authentication-type** is configured as password, the authentication key must be configured.

Either the **authentication-key** command or the **auth-keychain** command can be used by OSPF, but both cannot be supported at the same time. If both commands are configured, the **auth-keychain** configuration will be applied and the **authentication-key** command will be ignored.

By default, no authentication key is configured.

The **no** form of the command removes the authentication key.

## Default

```
no authentication-key
```

## Parameters

### *authentication-key*

the authentication key can be any combination of ASCII characters up to 8 characters in length (unencrypted). If spaces are used in the string, enclose the entire string in quotation marks (" ").

### *hash-key*

the hash key can be any combination of ASCII characters up to 22 characters in length (encrypted) or 121 characters in length (if the **hash2** parameter is used). If spaces are used in the string, enclose the entire string in quotation marks (" ").

This is useful when a user must configure the parameter, but, for security purposes, the actual unencrypted key value is not provided.

### **hash**

specifies that the key is entered in an encrypted form. If the **hash** parameter is not used, the key is assumed to be in a non-encrypted, clear text form. For security, all keys are stored in encrypted form in the configuration file with the **hash** parameter specified.

### **hash2**

specifies that the key is entered in a more complex encrypted form. If the **hash2** parameter is not used, the less encrypted hash form is assumed.

## authentication-type

## Syntax

```
authentication-type {password | message-digest}
```

## no authentication-type

### Context

```
config>router>ospf>area>interface  
config>router>ospf>area>virtual-link
```

### Description

This command enables authentication and specifies the type of authentication to be used on the OSPF interface.

Both simple **password** and **message-digest** authentication are supported.

By default, authentication is not enabled on an interface.

The **no** form of the command disables authentication on the interface.

### Default

no authentication-type

### Parameters

#### password

enables simple password (plaintext) authentication. If authentication is enabled and no authentication type is specified in the command, simple **password** authentication is enabled.

#### message-digest

enables message digest MD5 authentication in accordance with RFC 1321. If this option is configured, at least one message-digest-key must be configured.

## bfd-enable

### Syntax

```
bfd-enable [remain-down-on-failure]
```

```
no bfd-enable
```

### Context

```
config>router>ospf>area>interface  
config>router>ospf3>area>interface
```

### Description

This command enables the use of bidirectional forwarding (BFD) to control the state of the associated OSPF interface. By enabling BFD on an OSPF interface, the state of the interface is tied to the state of the BFD session between the local node and the remote node. The parameters used for BFD are set via the **bfd** command under the IP interface.

If the BFD session does not come back up within 10 s and the **remain-down-on-failure** parameter is enabled, OSPF will bring down the adjacency and wait for BFD to come up again. This behavior may

cause OSPF neighbors to flap because OSPF will form the adjacency and then bring it down if the BFD session is still down. If this parameter is not configured, the OSPF adjacency will form even if the BFD session does not come back up after a failure.

The **no** form of this command removes BFD from the associated OSPF adjacency.

## Default

no bfd-enable

## Parameters

### remain-down-on-failure

forces adjacency down on BFD failure

## dead-interval

## Syntax

**dead-interval** *seconds*

**no dead-interval**

## Context

config>router>ospf>area>interface

config>router>ospf>area>virtual-link

config>router>ospf3>area>interface

config>router>ospf3>area>virtual-link

## Description

This command configures the time, in seconds, that OSPF waits before declaring a neighbor router down. If no Hello packets are received from a neighbor for the duration of the dead interval, the router is assumed to be down. The minimum interval must be two times the hello interval.

The **no** form of the command reverts to the default value.

## Default

40

## Special cases

### OSPF interface

if the **dead-interval** configured applies to an interface, all nodes on the subnet must have the same dead interval

### Virtual link

if the **dead-interval** configured applies to a virtual link, the interval on both termination points of the virtual link must have the same dead interval

## Parameters

*seconds*

the dead interval in seconds, expressed as a decimal integer

**Values** 1 to 65535

## hello-interval

### Syntax

**hello-interval** *seconds*

**no hello-interval**

### Context

config>router>ospf>area>interface

config>router>ospf>area>virtual-link

config>router>ospf3>area>interface

config>router>ospf3>area>virtual-link

### Description

This command configures the interval between OSPF hellos issued on the interface or virtual link.

The hello interval, in combination with the dead interval, is used to establish and maintain the adjacency. Use this parameter to edit the frequency that Hello packets are sent.

Reducing the interval, in combination with an appropriate reduction in the associated **dead-interval** allows for faster detection of link and/or router failures but results in higher processing costs.

The **no** form of this command reverts to the default value.

### Default

10

### Special cases

#### OSPF interface

if the **hello-interval** configured applies to an interface, all nodes on the subnet must have the same hello interval

#### Virtual link

if the **hello-interval** configured applies to a virtual link, the interval on both termination points of the virtual link must have the same hello interval

## Parameters

*seconds*

the hello interval in seconds, expressed as a decimal integer

**Values** 1 to 65535

## interface-type

### Syntax

```
interface-type {broadcast | point-to-point}
no interface-type
```

### Context

```
config>router>ospf>area>interface
config>router>ospf3>area>interface
```

### Description

This command configures the interface type to be either broadcast or point-to-point.

Use this command to set the interface type of an Ethernet link to point-to-point to avoid having to carry the broadcast adjacency maintenance overhead of the link, provided that the link is used as a point-to-point link.

If the interface type is not known when the interface is added to OSPF, and the IP interface is subsequently bound (or moved) to a different interface type, this command must be entered manually.

The **no** form of the command reverts to the default value.

### Default

broadcast – if the physical interface is Ethernet or unknown  
point-to-point – if the physical interface is T1, E1, or SONET/SDH

### Special cases

#### Virtual link

a virtual link is always regarded as a point-to-point interface and is not configurable

### Parameters

#### broadcast

configures the interface to maintain this link as a broadcast network. To significantly improve adjacency forming and network convergence, a network should be configured as point-to-point if only two routers are connected, even if the network is a broadcast media such as Ethernet.

#### point-to-point

configures the interface to maintain this link as a point-to-point link

## lfa-policy-map

### Syntax

```
lfa-policy-map route-nh-template template-name
```

## no lfa-policy-map

### Context

```
config>router>ospf>area>interface  
config>router>ospf3>area>interface
```

### Description

This command applies a route next hop policy template to an OSPF interface.

When a route next hop policy template is applied to an interface, it is applied in all areas. However, this command can only be executed under the area in which the specified interface is primary. When the command is executed, the template is applied in that area and in all other areas where the interface is secondary. If the user attempts to execute the command under an area where the interface is secondary, the command will fail.

If the interface has been excluded from LFA with the [loopfree-alternate-exclude](#) command, the LFA policy has no effect on the interface.

If the route next hop policy template is applied to a loopback interface or to the system interface, the command will not be rejected, but the policy will have no effect on the interface.

The **no** form of the command deletes the mapping of a route next hop policy template to an OSPF interface.

### Default

```
no lfa-policy-map
```

### Parameters

*template-name*  
the name of an existing template

## message-digest-key

### Syntax

```
message-digest-key key-id md5 [key | hash-key] [hash | hash2]  
no message-digest-key key-id
```

### Context

```
config>router>ospf>area>interface  
config>router>ospf>area>virtual-link
```

### Description

This command configures a message digest key when MD5 authentication is enabled on the interface. Multiple message digest keys can be configured.

The **no** form of the command removes the message digest key identified by the *key-id*.



## Default

no message-digest-key

## Parameters

*key-id*

the *key-id* is expressed as a decimal integer

**Values** 1 to 255

*key*

the MD5 key, any alphanumeric string up to 16 characters in length

*hash-key*

the MD5 hash key, any combination of ASCII characters up to 33 characters in length (encrypted) or 132 characters in length (if the **hash2** parameter is used). If spaces are used in the string, enclose the entire string in quotation marks (" ").

This is useful when a user must configure the parameter, but, for security purposes, the actual unencrypted key value is not provided.

**hash**

specifies that the key is entered in an encrypted form. If the **hash** parameter is not used, the key is assumed to be in a unencrypted, clear text form. For security, all keys are stored in encrypted form in the configuration file with the **hash** parameter specified.

**hash2**

specifies that the key is entered in a more complex encrypted form. If the **hash2** parameter is not used, the less encrypted hash form is assumed.

## metric

## Syntax

**metric** *metric*

**no metric**

## Context

config>router>ospf>area>interface

config>router>ospf3>area>interface

## Description

This command configures an explicit route cost metric for the OSPF interface that overrides the metrics calculated based on the speed of the underlying link.

The **no** form of the command deletes the manually configured interface metric, so the interface uses the computed metric based on the **reference-bandwidth** command setting and the speed of the underlying link.

**Default**

no metric

**Parameters**

*metric*

the metric to be applied to the interface, expressed as a decimal integer

**Values** 1 to 65535

**mtu****Syntax**

**mtu** *bytes*

**no mtu**

**Context**

config>router>ospf>area>interface

config>router>ospf3>area>interface

**Description**

This command configures the OSPF or OSPFv3 interface MTU value used when negotiating an OSPF or OSPFv3 adjacency.

The operational OSPF MTU value is calculated as follows.

If this command is not configured:

- the OSPF or OSPFv3 interface operational MTU derives the MTU value from the IP interface MTU (which is derived from the port MTU); for example, port MTU minus 14 bytes for a null-encapsulated Ethernet port
  - for OSPF (not OSPFv3), if the derived MTU value is less than 576 bytes, the OSPF interface operational MTU is set to 576 bytes. If a lower interface MTU is required, you must explicitly configure it using this command.

If this command is configured:

- for OSPF (not OSPFv3):
  - if the OSPF interface MTU is less than 576 bytes, it becomes the operational OSPF MTU, regardless of the port MTU value
  - if the OSPF interface MTU is equal to or greater than 576 bytes, and the derived interface MTU is less than 576 bytes, the operational OSPF MTU is set to 576 bytes
  - if the OSPF interface MTU is equal to or greater than 576 bytes, and the derived interface MTU is greater than 576 bytes, the operational OSPF MTU is set to the lesser of the values configured with this command and the derived MTU

The port MTU must be set to 512 bytes or higher, since OSPF cannot support port MTU values lower than 512 bytes.

- for OSPFv3:

- the operational OSPF MTU is set to the lesser of the values configured with this command and the derived MTU
- this applies only when the port MTU is set to 1280 bytes or higher, since OSPFv3 cannot support port MTU values less than 1280 bytes

To determine the actual packet size, add 14 bytes for an Ethernet packet and 18 bytes for a tagged Ethernet packet to the size of the OSPF (IP) packet MTU configured with this command.

If the OSPF **mtu** command is configured to a value less than the interface or port MTU value, then the OSPF MTU value will be used to transmit OSPF packets.

Use the **no** form of this command to revert to the default.

## Default

**no mtu** – uses the value derived from the port MTU

## Parameters

*bytes*

the MTU to be used by OSPF or OSPFv3 for this logical interface in bytes

**Values** OSPF: 512 to 9710 (9724 – 14) (depends on the physical media)  
OSPFv3: 1280 to 9710 (9724 – 14) (depends on the physical media)

## node-sid

## Syntax

**node-sid index** *index-value*

**node-sid label** *label-value*

**no node-sid**

## Context

config>router>ospf>area>interface

## Description

This command assigns a node SID index or label value to the prefix representing the primary address of an IPv4 network interface of **type loopback**. Only a single node SID can be assigned to an interface. The secondary address of an IPv4 interface cannot be assigned a node SID index and does not inherit the SID of the primary IPv4 address.

This command fails if the network interface is not of **type loopback** or if the interface is defined in an IES or a VPRN context.

Assigning the same SID index or label value to the same interface in two different IGP instances is not allowed within the same node.

The value of the label or index SID is taken from the range configured for this IGP instance. When using the global mode of operation, the segment routing module checks that the same index or label value cannot be assigned to more than one loopback interface address. When using the per-instance mode of

operation, this check is not required because the index, and therefore the label ranges, of IGP instances are not allowed to overlap.

### Parameters

*index-value*

specifies the node SID index value

**Values** 0 to 4294967295

*label-value*

specifies the node SID label value

**Values** 0 to 4294967295

## passive

### Syntax

**[no] passive**

### Context

config>router>ospf>area>interface

config>router>ospf3>area>interface

### Description

This command adds the passive property to the OSPF interface where passive interfaces are advertised as OSPF interfaces but do not run the OSPF protocol.

By default, only interface addresses that are configured for OSPF will be advertised as OSPF interfaces. The **passive** parameter allows an interface to be advertised as an OSPF interface without running the OSPF protocol. While in passive mode, the interface will ignore ingress OSPF protocol packets and not transmit any OSPF protocol packets.

The **no** form of the command removes the passive property from the OSPF interface.

### Default

no passive

## priority

### Syntax

**priority** *number*

**no priority**

### Context

config>router>ospf>area>interface

```
config>router>ospf3>area>interface
```

### Description

This command configures the priority of the OSPF interface that is used in an election of the designated router on the subnet.

This parameter is only used if the interface is of type broadcast. The router with the highest-priority interface becomes the designated router. A router with priority 0 is not eligible to be a designated router or backup designated router.

The **no** form of the command resets the interface priority to the default value.

### Default

1

### Parameters

*number*

the interface priority expressed as a decimal integer

**Values** 0 to 255

## retransmit-interval

### Syntax

**retransmit-interval** *seconds*

**no retransmit-interval**

### Context

```
config>router>ospf>area>interface
```

```
config>router>ospf>area>virtual-link
```

```
config>router>ospf3>area>interface
```

### Description

This command specifies the length of time, in seconds, that OSPF will wait before retransmitting an unacknowledged link-state advertisement (LSA) to an OSPF neighbor.

The value should be longer than the expected round-trip delay between any two routers on the attached network. If the retransmit interval expires and no acknowledgment has been received, the LSA will be retransmitted.

The **no** form of this command reverts to the default interval.

### Default

5

## Parameters

*seconds*

the retransmit interval in seconds, expressed as a decimal integer

**Values** 1 to 1800

## sid-protection

### Syntax

**[no] sid-protection**

### Context

config>router>ospf>area>interface

### Description

This command enables or disables adjacency SID protection by LFA and remote LFA.

LFA and remote LFA Fast-Reroute (FRR) protection is enabled for all node SIDs and local adjacency SIDs when the user enables the **loopfree-alternate** option in IS-IS or OSPF at the LER and LSR. However, there may be applications where the user never wants traffic to divert from the strict hop computed by CSPF for an SR-TE LSP. In this case, the user can disable protection for all adjacency SIDs formed over a particular network IP interface using this command.

The protection state of an adjacency SID is advertised in the B-flag of the IS-IS or OSPF Adjacency SID sub-TLV.

### Default

sid-protection

## transit-delay

### Syntax

**transit-delay** *seconds*

**no transit-delay**

### Context

config>router>ospf>area>interface

config>router>ospf>area>virtual-link

config>router>ospf3>area>interface

config>router>ospf3>area>virtual-link

## Description

This command configures the estimated time, in seconds, that it takes to transmit a link-state advertisement (LSA) on the interface or virtual link.

The **no** form of this command reverts to the default delay time.

## Default

1

## Parameters

*seconds*

the transit delay in seconds, expressed as a decimal integer

**Values** 1 to 1800

## virtual-link

## Syntax

**[no] virtual-link** *router-id* **transit-area** *area-id*

## Context

config>router>ospf>area

config>router>ospf3>area

## Description

This command configures a virtual link to connect ABRs to the backbone.

The backbone area (area 0.0.0.0) must be contiguous and all other areas must be connected to the backbone area. If it is not practical or possible to connect an area to the backbone, the ABRs must be connected via a virtual link. The two ABRs form a point-to-point-like adjacency across the transit area. A virtual link can only be configured while in the area 0.0.0.0 context.

The *router-id* specified in this command must be associated with the virtual neighbor. The transit area cannot be a stub area or an NSSA.

The **no** form of the command deletes the virtual link.

## Default

no virtual-link

## Parameters

*router-id*

the router ID of the virtual neighbor in IP address dotted-decimal notation

*area-id*

the area ID specified identifies the transit area that links the backbone area to the area that has no physical connection with the backbone, expressed in dotted-decimal notation or as a 32-bit decimal integer

**Values** 0.0.0.0 to 255.255.255.255 (dotted-decimal) 0 to 4294967295 (decimal integer)

#### 4.14.2.2 Show commands



**Note:** The following command outputs are examples only; actual displays may differ depending on supported functionality and user configuration.

```
router
```

#### Syntax

```
router [router-instance]  
router service-name service-name
```

#### Context

```
show
```

#### Description

The command displays router instance information.



**Note:** Using a *service-id* or a *service-name* for this command applies only to VPRN service.

#### Parameters

*router-instance*

specifies either the router name or service ID

**Values** *router-name:* Base, management  
*service-id:* 1 to 2147483647

**Default** Base

*service-name*

specifies the service name, 64 characters maximum

```
ospf
```

#### Syntax

```
ospf [all]
```

#### Context

```
show>router
```



## Description

This command enables the context to display OSPF information.

## Parameters

**all**

shows all configured OSPF instances

ospf3

## Syntax

**ospf3** [**all**]

## Context

show>router

## Description

This command enables the context to display OSPFv3 information.

## Parameters

**all**

shows all configured OSPF3 instances

area

## Syntax

**area** [*area-id*] [**detail**] [**lfa**]

## Context

show>router>ospf

show>router>ospf3

## Description

This command displays configuration information for all areas or the specified area. When **detail** is specified, operational and statistical information will be displayed.

## Parameters

*area-id*

the OSPF area ID expressed in dotted-decimal notation or as a 32-bit decimal integer

**detail**

displays detailed information for the area

**lfa**

displays LFA next hop information

**Output**

The following outputs are examples of OSPF area information:

- OSPF detailed area information ([Output example, Table 39: Area field descriptions](#) )
- OSPF detailed LFA information ([Output example, Table 40: Area LFA field descriptions](#) )

**Output example**

```
*A: Sar18 Dut-B>show>router>ospf# area detail
=====
Rtr Base OSPFv2 Instance 0 Areas (detail)
=====
-----
Area Id: 0.0.0.1
-----
-----
Area Id       : 0.0.0.1           Type           : Standard
LFA           : Include
Virtual Links : 0                 Total Nbrs     : 0
Active IFs    : 0                 Total IFs      : 2
Area Bdr Rtrs : 0                 AS Bdr Rtrs   : 0
SPF Runs     : 0                 Last SPF Run   : Never
Router LSAs   : 0                 Network LSAs   : 0
Summary LSAs  : 0                 Asbr-summ LSAs : 0
Nssa ext LSAs : 0                 Area opaque LSAs : 0
Total LSAs    : 0                 LSA Cksum Sum : 0x0
Blackhole Range : True           Unknown LSAs   : 0
Export database : False
Export Policies : None
Export Fltrd LSAs : 0
Import Policies : None
Import Fltrd LSAs : 0
=====
*A: Sar18 Dut-B>show>router>ospf#
```

Table 39: Area field descriptions

Label	Description
Area Id	A 32-bit integer uniquely identifying an area
Type	NSSA: this area is configured as an NSSA area
	Standard: this area is configured as a standard area (not NSSA or stub)
	Stub: this area is configured as a stub area
LFA	Indicates whether interfaces in this area are included in the LFA SPF calculation
Virtual Links	The number of virtual links configured through this transit area
Total Nbrs	The total number of neighbors in this area

Label	Description
Active IFs	The active number of interfaces configured in this area
Total IFs	The total number of interfaces configured in this area
Area Bdr Rtrs	The total number of ABRs reachable within this area
AS Bdr Rtrs	The total number of ASBRs reachable within this area
SPF Runs	The number of times that the intra-area route table has been calculated using this area's link-state database
Last SPF Run	The time that the last intra-area SPF was run on this area
Router LSAs	The total number of router LSAs in this area
Network LSAs	The total number of network LSAs in this area
Summary LSAs	The summary of LSAs in this area
Asbr-summ LSAs	The summary of ASBR LSAs in this area
Nssa-ext LSAs	The total number of NSSA-EXT LSAs in this area
Area opaque LSAs	The total number of opaque LSAs in this area
Total LSAs	The sum of LSAs in this area excluding autonomous system external LSAs
LSA Cksum Sum	The 32-bit unsigned sum of the link-state database advertisements LS checksums contained in this area's link-state database. This checksum excludes AS External LSAs (type 5).
LSA Count	The total number of link-state advertisements in this area's link-state database, excluding AS External LSAs
Blackhole Range	False: no blackhole route is installed for aggregates configured in this area True: a lowest-priority blackhole route is installed for aggregates configured in this area
Unknown LSAs	The total number of unknown LSAs in this area
Export database	n/a
Export Policies	n/a
Export Flitrd LSAs	n/a
Import Policies	n/a
Import Flitrd LSAs	n/a
No. of OSPF Areas	The number of areas configured on the router

**Output example**

```
A:ALU-A# show router ospf 0 area 0.0.0.0 lfa detail
=====
Rtr Base OSPFv2 Instance 0 Path Table (detail)
=====
-----
OSPF Area : 0.0.0.0
-----
Node           : 10.20.1.1           Metric           : 10
Interface      : In-A1              Nexthop          : 10.20.1.1
LFA Interface  : In-C1              LFA Metric       : 20
LFA type       : linkProtection     LFA Nexthop     : 10.20.1.3

Node           : 10.20.1.3           Metric           : 10
Interface      : In-C1              Nexthop          : 10.20.1.3
LFA Interface  : In-A1              LFA Metric       : 20
LFA type       : linkProtection     LFA Nexthop     : 10.20.1.1

Node           : 10.20.1.4           Metric           : 10
Interface      : In-D1              Nexthop          : 10.20.1.4

Node           : 10.20.1.6           Metric           : 20
Interface      : In-D1              Nexthop          : 10.20.1.4
LFA Interface  : In-C1              LFA Metric       : 30
LFA type       : nodeProtection     LFA Nexthop     : 10.20.1.3
=====
```

Table 40: Area LFA field descriptions

Label	Description
Node	The IP address of the source node
Metric	The cost to the primary route next hop
Interface	The interface name of the primary next hop
Nexthop	The IP address of the primary next hop
LFA Interface	The interface name of the LFA backup next hop
LFA Metric	The cost to the LFA backup next hop
LFA type	The LFA protection type: link protection or node protection
LFA Nexthop	The IP address of the LFA backup next hop

**capabilities**

**Syntax**

**capabilities** [router-id]

### Context

```
show>router>ospf
show>router>ospf3
```

### Description

This command displays the entries in the Router Information (RI) LSAs.

### Parameters

*router-id*

lists only the LSAs related to that router ID. If no *router-id* is specified, all database entries are listed.

### Output

The following output is an example of OSPF capabilities information, and [Table 41: Router capabilities field descriptions](#) describes the fields.

#### Output example

```
*A:7705:Dut-A# show router ospf capabilities
=====
Rtr Base OSPFv2 Instance 0 Capabilities
=====
scope      Router Id      Capabilities
-----
Area       10.20.1.1     0x38000000: Stub TE P2P-VLAN
                SR Algorithm:
                Backup-constrained-SPF
                IGP-metric-based-SPF
                SR Label Range: start label 20000 range 10001
Area       10.20.1.3     0x38000000: Stub TE P2P-VLAN
                SR Algorithm:
                Backup-constrained-SPF
                IGP-metric-based-SPF
                SR Label Range: start label 20000 range 10001
Area       10.20.1.4     0x38000000: Stub TE P2P-VLAN
                SR Algorithm:
                Backup-constrained-SPF
                IGP-metric-based-SPF
                SR Label Range: start label 20000 range 10001
Area       10.20.1.5     0x38000000: Stub TE P2P-VLAN
                SR Algorithm:
                Backup-constrained-SPF
                IGP-metric-based-SPF
                SR Label Range: start label 20000 range 10001
Area       10.20.1.6     0x38000000: Stub TE P2P-VLAN
                SR Algorithm:
                Backup-constrained-SPF
                IGP-metric-based-SPF
                SR Label Range: start label 20000 range 10001
Area       10.20.1.22    0x38000000: Stub TE P2P-VLAN
                SR Algorithm:
                Backup-constrained-SPF
                IGP-metric-based-SPF
                SR Label Range: start label 20000 range 10001
-----
No. of LSAs: 6
=====
```

\*A:7705:Dut-A#

Table 41: Router capabilities field descriptions

Label	Description
Scope	The LSA type
Router ID	The OSPF area identifier
Capabilities	The link-state ID is an LSA type-specific field containing either a number to distinguish several LSAs from the same router, an interface ID, or a router ID; it identifies the piece of the routing domain being described by the advertisement

## database

### Syntax

**database** [**type** {**router** | **network** | **summary** | **asbr-summary** | **external** | **nssa** | **all**}] [**area** *area-id*] [**adv-router** *router-id*] [*link-state-id*] [**detail**] [**filtered**]

**database** [**type** {**router** | **network** | **inter-area-pfx** | **inter-area-rtr** | **external** | **nssa** | **intra-area-pfx** | **rtr-info** | **all**}] [**area** *area-id*] [**adv-router** *router-id*] [*link-state-id*] [**detail**] [**filtered**]

### Context

```
show>router>ospf
show>router>ospf3
```

### Description

This command displays information about the OSPF link-state database.

When no command line options are specified, the command displays a summary output for all database entries.

### Parameters

#### **type**

specifies to filter the OSPF LSDB information based on the specified database type

#### **router**

displays only router (Type 1) LSAs in the LSDB

#### **network**

displays only network (Type 2) LSAs in the LSDB

#### **summary**

displays only summary (Type 3) LSAs in the LSDB

#### **asbr-summary**

displays only ASBR summary (Type 4) LSAs in the LSDB

**external**

displays only AS external (Type 5) LSAs in the LSDB. External LSAs are maintained globally and not per area. If the display of external links is requested, the area parameter, if present, is ignored.

**nssa**

displays only NSSA area-specific AS external (Type 7) LSAs in the LSDB

**inter-area-pfx**

displays inter-area prefix LSAs

**inter-area-rtr**

displays inter-area router LSAs

**intra-area-pfx**

displays intra-area prefix LSAs

**rtr-info**

displays router info LSAs

**all**

displays all LSAs in the LSDB. The all keyword is intended to be used with either the **area area-id** or the **adv-router router-id [link-state-id]** parameters.

**area area-id**

displays LSDB information associated with the specified OSPF *area-id*

**Values** ip-address – a.b.c.d  
 area – 0 to 4294967295

**adv-router router-id [link-state-id]**

displays LSDB information associated with the specified advertising router. To further narrow the number of items displayed, the *link-state-id* can optionally be specified.

**detail**

displays detailed information about the LSDB entries

**filtered**

displays LSDB entries that were filtered by an area import or export policy

**Output**

The following output is an example of OSPF database information, and [Table 42: Database field descriptions](#) describes the fields.

**Output example**

```
A:ALU-A# show router ospf database
=====
Rtr Base OSPFv2 Instance 0 Link State Database (type : All)
=====
Type          Area ID      Link State Id  Adv Rtr Id    Age  Sequence      Cksum
-----
Router        0.0.0.0     10.0.0.2      10.0.0.2     1800 0x800000b6  0xf54
Router        0.0.0.0     10.0.0.5      10.0.0.5     1902 0x8000009d  0xcb7c
Router        0.0.0.0     10.0.0.8      10.0.0.8     1815 0x8000009a  0x529b
Router        0.0.0.0     10.0.0.9      10.0.0.9     1156 0x80000085  0xd00f
```

Router	0.0.0.0	10.0.0.10	10.0.0.10	533	0x8000009d	0x3f1f
Router	0.0.0.0	10.0.0.11	10.0.0.11	137	0x80000086	0xc58f
Router	0.0.0.0	10.0.0.12	10.0.0.12	918	0x8000009d	0x4cf3
Router	0.0.0.0	10.0.0.13	10.0.0.13	1401	0x800000a2	0x879c
Network	0.0.0.0	10.0.53.28	10.0.0.28	149	0x80000083	0xe5cd
Network	0.0.0.0	10.0.54.28	10.0.0.28	1259	0x80000083	0xdad7
Summary	0.0.0.0	10.0.0.15	10.0.0.10	378	0x80000084	0xeba1
Summary	0.0.0.0	10.0.0.15	10.0.0.12	73	0x80000084	0xdfab
Summary	0.0.0.0	10.0.0.18	10.0.0.10	1177	0x80000083	0xcfbb
Summary	0.0.0.1	10.100.25.4	10.0.0.12	208	0x80000091	0x3049
AS Summ	0.0.0.1	10.0.0.8	10.0.0.10	824	0x80000084	0x3d07
AS Summ	0.0.0.1	10.0.0.8	10.0.0.12	1183	0x80000095	0x4bdf
AS Summ	0.0.0.1	10.0.0.9	10.0.0.10	244	0x80000082	0x73cb
AS Ext	n/a	10.1.0.0	10.0.0.23	1312	0x80000083	0x45e7
AS Ext	n/a	10.2.0.0	10.0.0.23	997	0x80000082	0x45e6
AS Ext	n/a	10.20.0.0	10.0.0.23	238	0x80000081	0x2d81
...						

-----  
 No. of LSAs: 339  
 =====

A:ALU-A# show router ospf database detail

-----  
 Rtr Base OSPFv2 Instance 0 Link State Database (type : All) (detail)  
 -----

Router LSA for Area 0.0.0.0  
 -----

Area Id	: 0.0.0.0	Adv Router Id	: 10.0.0.2
Link State Id	: 10.0.0.2	LSA Type	: Router
Sequence No	: 0x800000b7	Checksum	: 0xd55
Age	: 155	Length	: 192
Options	: E		
Flags	: None	Link Count	: 14
Link Type (1)	: Point To Point		
Nbr Rtr Id (1)	: 10.0.0.13	I/F Address (1)	: 10.0.22.2
No of TOS (1)	: 0	Metric-0 (1)	: 25
Link Type (2)	: Stub Network		
Network (2)	: 10.0.22.0	Mask (2)	: 255.255.255.0
No of TOS (2)	: 0	Metric-0 (2)	: 25
Link Type (3)	: Point To Point		
Nbr Rtr Id (3)	: 10.0.0.12	I/F Address (3)	: 10.0.5.2
No of TOS (3)	: 0	Metric-0 (3)	: 25
Link Type (4)	: Stub Network		
Network (4)	: 10.0.5.0	Mask (4)	: 255.255.255.0
No of TOS (4)	: 0	Metric-0 (4)	: 25
Link Type (5)	: Point To Point		
Nbr Rtr Id (5)	: 10.0.0.8	I/F Address (5)	: 10.0.13.2
No of TOS (5)	: 0	Metric-0 (5)	: 6
Link Type (6)	: Stub Network		
Network (6)	: 10.0.13.0	Mask (6)	: 255.255.255.0
No of TOS (6)	: 0	Metric-0 (6)	: 6
Link Type (7)	: Point To Point		
Nbr Rtr Id (7)	: 10.0.0.5	I/F Address (7)	: 10.0.14.2
No of TOS (7)	: 0	Metric-0 (7)	: 6
Link Type (8)	: Stub Network		
Network (8)	: 10.0.14.0	Mask (8)	: 255.255.255.0
No of TOS (8)	: 0	Metric-0 (8)	: 6
Link Type (9)	: Point To Point		
Nbr Rtr Id (9)	: 10.0.0.11	I/F Address (9)	: 10.0.17.2
No of TOS (9)	: 0	Metric-0 (9)	: 25
Link Type (10)	: Stub Network		
Network (10)	: 10.0.17.0	Mask (10)	: 255.255.255.0
No of TOS (10)	: 0	Metric-0 (10)	: 25



```

Link Type (11) : Stub Network
Network (11)   : 10.0.0.2           Mask (11)      : 255.255.255.255
No of TOS (11) : 0                 Metric-0 (11)  : 1
Link Type (12) : Stub Network
Network (12)   : 10.0.18.0        Mask (12)      : 255.255.255.0
No of TOS (12) : 0                 Metric-0 (12)  : 24
Link Type (13) : Point To Point
Nbr Rtr Id (13) : 10.0.0.10      I/F Address (13) : 10.0.3.2
No of TOS (13) : 0                 Metric-0 (13)  : 25
Link Type (14) : Stub Network
Network (14)   : 10.0.3.0         Mask (14)      : 255.255.255.0
No of TOS (14) : 0                 Metric-0 (14)  : 25
    
```

-----  
AS Ext LSA for Network 10.0.0.14  
-----

```

Area Id       : N/A                Adv Router Id  : 10.0.0.10
Link State Id : 10.0.0.14          LSA Type      : AS Ext
Sequence No   : 0x80000083         Checksum      : 0xa659
Age           : 2033                Length        : 36
Options       : E
Network Mask  : 255.255.255.255    Fwding Address : 10.1.6.15
Metric Type   : Type 2              Metric-0      : 4
Ext Route Tag : 0
    
```

Table 42: Database field descriptions

Label	Description
Type/ LSA Type	The LSA type
Area ID	The OSPF area identifier
Link State ID	The link-state ID is an LSA type-specific field containing either a number to distinguish several LSAs from the same router, an interface ID, or a router ID; it identifies the piece of the routing domain being described by the advertisement
Adv Rtr Id/ Adv Router Id	The router identifier of the router advertising the LSA
Age	The age of the link-state advertisement in seconds
Sequence/ Sequence No	The signed 32-bit integer sequence number
Cksum/ Checksum	The 32-bit unsigned sum of the link-state advertisements' LS checksums
No. of LSAs	The number of LSAs displayed
Options	EA: external attribute LSA support
	DC: demand circuit support
	R: if clear, a node can participate in OSPF topology distribution without being used to forward transit traffic

Label	Description
	N: type 7 LSA support
	MC: multicast support (not applicable)
	E: external routes support
	V6: not applicable
Prefix Options	P: propagate NSSA LSA
	MC: multicast support (not applicable)
	LA: local address capability; if set, the prefix is an IPv6 interface address of the advertising router (not applicable)
	NU: no unicast capability; if set, the prefix is excluded from IPv6 unicast calculations (not applicable)
Flags	None: no flags set
	V: the router is an endpoint for one or more fully adjacent virtual links having the described area as the transit area
	E: the router is an AS Boundary Router
	B: the router is an Area Border Router
Link Count	The number of links advertised in the LSA
Link Type ( <i>n</i> )	The link type of the <i>n</i> th link in the LSA
Network ( <i>n</i> )	The network address of the <i>n</i> th link in the LSA
Metric-0 ( <i>n</i> )	The cost metric of the <i>n</i> th link in the LSA

## interface

### Syntax

**interface** [area *area-id*] [detail]

**interface** [*ip-int-name* | *ip-address*] [detail]

**interface** [*ip-int-name* | *ip-address*] **database** [detail]

**interface** [*ip-int-name* | *ip-address* | *ipv6-address*] [detail]

**interface** [*ip-int-name* | *ip-address* | *ipv6-address*] **database** [detail]

### Context

show>router>ospf

show>router>ospf3

### Description

This command displays the details of the OSPF interface, which can be identified by IP address or IP interface name. If neither is specified, all in-service interfaces are displayed. The *ipv6-address* applies only in the **ospf3** context.

The **area** option displays all interfaces configured in the specified area.

The **detail** option produces a great amount of data. It is recommended that this option be used only when requesting a specific interface.

### Parameters

*area-id*

displays all interfaces configured in this area

*ip-int-name*

displays only the interface identified by this interface name

*ip-address*

displays only the interface identified by this IP address

*ipv6-address*

displays only the interface identified by this IPv6 address

**database**

displays detailed information about the database for this interface

**detail**

displays detailed information for the interface

### Output

The following outputs are examples of OSPF interface information:

- OSPF standard interface information ([Output example, Table 43: Interface field descriptions](#) )
- OSPF detailed interface information ([Output example, Table 44: Detailed interface field descriptions](#) )

#### Output example

```
A:ALU-A# show router ospf interface
=====
Rtr Base OSPFv2 Instance 0 Interface
=====
If Name          Area Id          Designated Rtr  Bkup Desig Rtr  Adm  Oper
-----
system          0.0.0.1          10.10.10.104   0.0.0.0          Up   DR
to-103          0.0.0.20         0.0.0.0        0.0.0.0          Up   Down
-----
No. of OSPF Interfaces: 2
=====
```

Table 43: Interface field descriptions

Label	Description
If Name	The interface name

Label	Description
Area Id	A 32-bit integer uniquely identifying the area to which this interface is connected; area ID 0.0.0.0 is used for the OSPF backbone
Designated rtr	The IP interface address of the router identified as the designated router for the network in which this interface is configured Set to 0.0.0.0 if there is no designated router
Bkup Desig Rtr	The IP interface address of the router identified as the backup designated router for the network in which this interface is configured Set to 0.0.0.0 if there is no backup designated router
Adm	Dn: OSPF on this interface is administratively shut down
	Up: OSPF on this interface is administratively enabled
Oper	Down: the initial interface state. In this state, the lower-level protocols have indicated that the interface is unusable.
	Wait: the router is trying to determine the identity of the (backup) designated router for the network
	PToP: the interface is operational, and connects either to a physical point-to-point network or to a virtual link
	DR: this router is the designated router for this network
	BDR: this router is the backup designated router for this network
	ODR: the interface is operational and part of a broadcast or NBMA network on which another router has been selected to be the designated router
No. of OSPF Interfaces	The number of interfaces listed

**Output example**

```
*A:7705:Dut-C# show router 10 ospf interface "iftoA-1" detail
```

```
=====
Rtr vprn10 OSPFv2 Instance 0 Interface "iftoA-1" (detail)
=====
-----
Configuration
-----
IP Address      : 10.1.1.3
Area Id        : 0.0.0.0
Hello Intrvl   : 1 sec
Retrans Intrvl : 5 sec
Cfg Metric     : 1000
Priority        : 1
Rtr Dead Intrvl : 4 sec
Poll Intrvl    : 120 sec
Advert Subnet  : True
```

```

Transit Delay      : 1                Cfg IF Type       : Broadcast
Passive           : False             Cfg MTU           : 1500
LSA-filter-out    : None              Adv Rtr Capab     : Yes
LFA               : Include          LFA NH Template   :
Load Bal Weight   : 50
Auth Type         : None
-----
State
-----
Admin Status      : Enabled           Oper State        : Backup Desig Rtr
Designated Rtr   : 1.1.1.1          Backup Desig Rtr : 3.3.3.3
IF Type          : Broadcast         Network Type      : Transit
Oper MTU         : 1500             Last Enabled     : 03/15/2022 12:37:41
Oper Metric      : 1000             Bfd Enabled      : No
Te Metric        : 1000             Te State         : Down
Admin Groups     : None
Ldp Sync         : outOfService      Ldp Sync Wait    : Disabled
Ldp Timer State  : Disabled          Ldp Tm Left     : 0
-----
Statistics
-----
Nbr Count        : 1                If Events         : 4
Tot Rx Packets   : 2158            Tot Tx Packets    : 2155
Rx Hellos        : 2127            Tx Hellos         : 2128
Rx DBDs          : 3                Tx DBDs           : 2
Rx LSRs          : 1                Tx LSRs           : 1
Rx LSUs          : 22              Tx LSUs           : 6
Rx LS Acks       : 5                Tx LS Acks        : 18
Retransmits      : 0                Discards          : 0
Bad Networks     : 0                Bad Virt Links    : 0
Bad Areas        : 0                Bad Dest Adrs     : 0
Bad Auth Types   : 0                Auth Failures     : 0
Bad Neighbors    : 0                Bad Pkt Types     : 0
Bad Lengths      : 0                Bad Hello Int.    : 0
Bad Dead Int.    : 0                Bad Options       : 0
Bad Versions     : 0                Bad Checksums     : 0
LSA Count        : 0                LSA Checksum      : 0x0
=====
*A:7705:Dut-C#
    
```

Table 44: Detailed interface field descriptions

Label	Description
IP Address	The IP address and mask of this OSPF interface
Area Id	A 32-bit integer uniquely identifying the area to which this interface is connected; area ID 0.0.0.0 is used for the OSPF backbone
Priority	The priority of this interface. Used in multi-access networks, this field is used in the designated router election algorithm.
Hello Intrvl	The length of time, in seconds, between the Hello packets that the router sends on the interface. This value must be the same for all routers attached to a common network.
Rtr Dead Intrvl	The number of seconds that a router's Hello packets have not been seen before its neighbors declare the router down. This

Label	Description
	should be some multiple of the Hello interval. This value must be the same for all routers attached to a common network.
Retrans Intrvl	The number of seconds between link-state advertisement retransmissions, for adjacencies belonging to this interface. This value is also used when retransmitting database description and link-state request packets.
Poll Intrvl	The larger time interval, in seconds, between the Hello packets sent to an inactive non-broadcast multi-access neighbor
Cfg Metric	The metric to be advertised for this interface
Advert Subnet	False: when a point-to-point interface is configured as false, then the subnet is not advertised and the endpoints are advertised as host routes
	True: when a point-to-point interface is configured as true, then the subnet is advertised
Transit Delay	The estimated number of seconds it takes to transmit a link-state update packet over this interface
Cfg IF Type	The configured interface type
Passive	False: this interfaces operates as a normal OSPF interface with regard to adjacency forming and network and link behavior
	True: no OSPF Hellos will be sent out on this interface and the router advertises this interface as a stub network or link in its router LSAs
Cfg MTU	The desired size of the largest packet that can be sent or received on this OSPF interface, specified in octets. This size does include the underlying IP header length, but not the underlying layer headers and trailers.
LFA	Indicates whether the interface is included in the LFA SPF calculation
LSA-filter-out	Indicates whether there is filtering of outgoing OSPF LSAs
Adv Rtr Capab	Indicates whether the router advertising the LSA is configured
LFA NH Template	Indicates whether an LFA next hop policy template is applied to this interface
Load Bal Weight	Indicates the load-balancing weight value
Auth Type	Identifies the authentication procedure to be used for the packet
	None: routing exchanges over the network/subnet are not authenticated

Label	Description
	Simple: a 64-bit field is configured on a per-network basis. All packets sent on a particular network must have this configured value in their OSPF header 64-bit authentication field. This essentially serves as a "clear" 64-bit password.
	MD5: a shared secret key is configured on all routers attached to a common network or subnet. For each OSPF protocol packet, the key is used to generate and verify a "message digest" that is appended to the end of the OSPF packet.
Admin Status	Disabled: OSPF on this interface is administratively shut down
	Enabled: OSPF on this interface is administratively enabled
Oper State	Down: the initial interface state. In this state, the lower-level protocols have indicated that the interface is unusable.
	Waiting: the router is trying to determine the identity of the (backup) designated router for the network
	Point To Point: the interface is operational and connects either to a physical point-to-point network or to a virtual link
	Designated Rtr: this router is the designated router for this network
	Other Desig Rtr: the interface is operational and part of a broadcast or NBMA network on which another router has been selected to be the designated router
	Backup Desig Rtr: this router is the backup designated router for this network
Designated Rtr	<p>The IP interface address of the router identified as the designated router for the network in which this interface is configured</p> <p>Set to 0.0.0.0 if there is no designated router</p>
Backup Desig Rtr	<p>The IP interface address of the router identified as the backup designated router for the network in which this interface is configured</p> <p>Set to 0.0.0.0 if there is no backup designated router</p>
IF Type	Broadcast: LANs, such as Ethernet
	NBMA: X.25, Frame Relay and similar technologies
	Point-To-Point: links that are definitively point-to-point

Label	Description
Network Type	Stub: OSPF has not established a neighbor relationship with any other OSPF router on this network; therefore, only traffic sourced or destined for this network will be routed to this network
	Transit: OSPF has established at least one neighbor relationship with another OSPF router on this network; therefore, traffic en route to other networks may be routed via this network
Oper MTU	The operational size of the largest packet that can be sent or received on this OSPF interface, specified in octets. This size includes the underlying IP header length, but not the underlying layer headers and trailers.
Last Enabled	The time that this interface was last enabled to run OSPF on this interface
Oper Metric	The size of the operational metric size configured for this interface
BFD Enabled	Specifies whether BFD is enabled or disabled the for this interface
Te Metric	The TE metric configured for this interface. This metric is flooded out in the TE metric sub-TLV in the OSPF TE LSAs. Depending on the configuration, either the TE metric value or the native OSPF metric value is used in CSPF computations.
Te State	The MPLS interface TE status from OSPF standpoint
Admin Groups	The bit-map inherited from the MPLS interface that identifies the admin groups to which this interface belongs
Ldp Sync	Specifies whether the IGP-LDP synchronization feature is enabled or disabled on all interfaces participating in the OSPF routing protocol
Ldp Sync Wait	The time to wait for the LDP adjacency to come up
Ldp Timer State	The state of the LDP sync time left on the OSPF interface
Ldp Tm Left	The time left before OSPF reverts back to advertising normal metrics for this interface
Nbr Count	The number of OSPF neighbors on the network for this interface
If Events	The number of times this OSPF interface has changed its state, or an error has occurred since this interface was last enabled
Tot Rx Packets	The total number of OSPF packets received on this interface since this interface was last enabled



Label	Description
Tot Tx Packets	The total number of OSPF packets transmitted on this interface since this interface was last enabled
Rx Hellos	The total number of OSPF Hello packets received on this interface since this interface was last enabled
Tx Hellos	The total number of OSPF Hello packets transmitted on this interface since this interface was last enabled
Rx DBDs	The total number of OSPF database description packets received on this interface since this interface was last enabled
Tx DBDs	The total number of OSPF database description packets transmitted on this interface since this interface was last enabled
Rx LSRs	The total number of Link-State Requests (LSRs) received on this interface since this interface was last enabled
Tx LSRs	The total number of Link-State Requests (LSRs) transmitted on this interface since this interface was last enabled
Rx LSUs	The total number of Link-State Updates (LSUs) received on this interface since this interface was last enabled
Tx LSUs	The total number of Link-State Updates (LSUs) transmitted on this interface since this interface was last enabled
Rx LS Acks	The total number of Link-State Acknowledgments received on this interface since this interface was last enabled
Tx LS Acks	The total number of Link-State Acknowledgments transmitted on this interface since this interface was last enabled
Retransmits	The total number of OSPF retransmits sent on this interface since this interface was last enabled
Discards	The total number of OSPF packets discarded on this interface since this interface was last enabled
Bad Networks	The total number of OSPF packets received with invalid network or mask since this interface was last enabled
Bad Virt Links	The total number of OSPF packets received on this interface that are destined for a virtual link that does not exist since this interface was last enabled
Bad Areas	The total number of OSPF packets received with an area mismatch since this interface was last enabled
Bad Dest Addr	The total number of OSPF packets received with the incorrect IP destination address since this interface was last enabled

Label	Description
Bad Auth Types	The total number of OSPF packets received with an invalid authorization type since this interface was last enabled
Auth Failures	The total number of OSPF packets received with an invalid authorization key since this interface was last enabled
Bad Neighbors	The total number of OSPF packets received where the neighbor information does not match the information this router has for the neighbor since this interface was last enabled
Bad Pkt Types	The total number of OSPF packets received with an invalid OSPF packet type since this interface was last enabled
Bad Lengths	The total number of OSPF packets received on this interface with a total length not equal to the length given in the packet itself since this interface was last enabled
Bad Hello Int.	The total number of OSPF packets received where the hello interval given in the packet was not equal to that configured on this interface since this interface was last enabled
Bad Dead Int.	The total number of OSPF packets received where the dead interval given in the packet was not equal to that configured on this interface since this interface was last enabled
Bad Options	The total number of OSPF packets received with an option that does not match those configured for this interface or area since this interface was last enabled
Bad Versions	The total number of OSPF packets received with bad OSPF version numbers since this interface was last enabled
Bad Checksums	The total number of OSPF packets received with bad checksums since this interface was last enabled
LSA Count	The total number of link-state advertisements in this area's link-state database, excluding AS External LSAs
LSA Checksum	The 32-bit unsigned sum of the link-state database advertisements' LS checksums contained in this area's link-state database. This checksum excludes AS External LSAs (type 5).

## lfa-coverage

### Syntax

#### lfa-coverage

**Context**

```
show>router>ospf
show>router>ospf3
```

**Description**

This command displays OSPF LFA coverage information.

**Output**

The following output is an example of LFA coverage information, and [Table 45: LFA coverage field descriptions](#) describes the fields.

**Output example**

```
A:ALU-A# show router ospf lfa-coverage
=====
Rtr Base OSPFv2 Instance 0 LFA Coverage
=====
Area                Node                Prefix
-----
0.0.0.0             4/4 (100%)         8/8 (100%)
=====
A:ALU-A#
```

Table 45: LFA coverage field descriptions

Label	Description
Area	The OSPF area in which LFA is enabled
Node	The number of nodes in the area on which LFA is enabled
Prefix	The number of interfaces on the nodes on which LFA is enabled

**neighbor****Syntax**

**neighbor** [*ip-int-name* | *ip-address*] [**detail**]

**neighbor overview**

**neighbor** [*remote ip-address*] [**detail**]

**neighbor** [*ip-int-name*] [*router-id*] [**detail**]

**Context**

```
show>router>ospf
show>router>ospf3
```

## Description

This command displays all neighbor information or all information about neighbors of a router identified by interface name or router ID.

The **detail** option produces a large amount of data. It is recommended that this option be used only when requesting a specific neighbor.

## Parameters

*ip-int-name*

displays neighbor information only for neighbors of the interface identified by the interface name

*ip-address*

displays neighbor information for the neighbor identified by the specified IPv4 address

**detail**

displays detailed information for the interface

**overview**

displays overview information for the interface

**remote** *ip-address*

displays information for a far-end neighbor, identified by the IP address. This parameter applies only in the **ospf** context.

*router-id*

Displays information for the neighbor identified by the router ID. This parameter only applies in the **ospf3** context.

## Output

The following outputs are examples of OSPF neighbor information:

- OSPF standard neighbor information ([Output example, Table 46: Neighbor field descriptions](#) )
- OSPF neighbor (detail) information ([Output example, Table 47: Neighbor \(detail\) field descriptions](#) )
- OSPF neighbor (overview) information ([Output example, Table 48: Neighbor \(overview\) field descriptions](#) )

### Output example

```
A:ALU-A# show router ospf neighbor
=====
Rtr Base OSPFv2 Instance 0 Neighbors
=====
Interface-Name          Rtr Id          State    Pri  RetxQ  TTL
-----
pc157-2/1                10.13.8.158    Full     1    0      37
pc157-2/2                10.13.7.165    Full    100  0      33
pc157-2/3                10.13.6.188    Full     1    0      38
-----
No. of Neighbors: 3
```

Table 46: Neighbor field descriptions

Label	Description
Interface-Name	The interface name or IP address this neighbor is using in its IP source address. On links with no address, this will not be 0.0.0.0, but the address of another of the neighbor's interfaces.
Rtr Id	A 32-bit integer uniquely identifying the neighboring router in the autonomous system
State	Down: the initial state of a neighbor conversation. It indicates that there has been no recent information received from the neighbor.
	Attempt: this state is only valid for neighbors attached to NBMA networks. It indicates that no recent information has been received from the neighbor, but that a more concerted effort should be made to contact the neighbor.
	Init: in this state, a Hello packet has recently been seen from the neighbor. However, bidirectional communication has not yet been established with the neighbor (that is, the router itself did not appear in the neighbor's Hello packet).
	Two Way: in this state, communication between the two routers is bidirectional
	ExchStart: the first step in creating an adjacency between the two neighboring routers. The goal of this step is to decide which router is the master, and to decide upon the initial database descriptor sequence number.
	Exchange: in this state, the router is describing its entire link-state database by sending database description packets to the neighbor
	Loading: in this state, Link-State Request packets are sent to the neighbor asking for the more recent LSAs that have been discovered (but not yet received) in the Exchange state
	Full: in this state, the neighboring routers are fully adjacent. These adjacencies will now appear in router-LSAs and network-LSAs.
Pri	The priority of this neighbor in the designated router election algorithm. The value 0 signifies that the neighbor is not eligible to become the designated router on this particular network.
RetxQ	The current length of the retransmission queue

Label	Description
TTL	The time until this neighbor is declared down; this timer is set to the dead router interval when a valid Hello packet is received from the neighbor
No. of Neighbors	The number of adjacent OSPF neighbors on this interface

**Output example**

```
A:ALU-A# show router ospf neighbor 10.13.8.150 detail
=====
Rtr Base OSPFv2 Instance 0 Neighbors (detail)
-----
Neighbor Rtr Id   : 10.13.8.158           Interface: pc157-2/1
-----
Neighbor IP Addr : 10.16.1.8
Local IF IP Addr : 10.16.1.7
Area Id          : 0.0.0.0
Designated Rtr  : 0.0.0.0               Backup Desig Rtr : 0.0.0.0
Neighbor State   : Full                  Priority          : 1
Retrans Q Length: 0                      Options           : -E--0-
Events           : 4                      Last Event Time  : 05/06/2015 00:11:16
Up Time          : 1d 18:20:20           Time Before Dead : 38 sec
Bad Nbr States   : 1                      LSA Inst fails   : 0
Bad Seq Nums     : 0                      Bad MTUs         : 0
Bad Packets      : 0                      LSA not in LSDB : 0
Option Mismatches: 0                      Nbr Duplicates   : 0
Num Restarts     : 0                      Last Restart at  : Never
-----
A:ALU-A#
```

Table 47: Neighbor (detail) field descriptions

Label	Description
Neighbor IP Addr	The IP address this neighbor is using in its IP source address. On links with no IP address, this will not be 0.0.0.0, but the address of another of the neighbor's interfaces.
Local IF IP Addr	The IP address of this OSPF interface
Area Id	A 32-bit integer uniquely identifying the area to which this interface is connected; area ID 0.0.0.0 is used for the OSPF backbone
Designated Rtr	The IP interface address of the router identified as the designated router for the network in which this interface is configured  Set to 0.0.0.0 if there is no designated router
Neighbor Rtr Id	A 32-bit integer uniquely identifying the neighboring router in the AS

Label	Description
Neighbor State	Down: the initial state of a neighbor conversation. It indicates that there has been no recent information received from the neighbor.
	Attempt: this state is only valid for neighbors attached to NBMA networks. It indicates that no recent information has been received from the neighbor, but that a more concerted effort should be made to contact the neighbor.
	Init: in this state, a Hello packet has recently been seen from the neighbor. However, bidirectional communication has not yet been established with the neighbor (that is, the router itself did not appear in the neighbor's Hello packet).
	Two Way: in this state, communication between the two routers is bidirectional
	Exchange start: the first step in creating an adjacency between the two neighboring routers. The goal of this step is to decide which router is the master, and to decide upon the initial database descriptor sequence number.
	Exchange: in this state, the router is describing its entire link-state database by sending database description packets to the neighbor
	Loading: in this state, Link-State Request packets are sent to the neighbor asking for the more recent LSAs that have been discovered (but not yet received) in the Exchange state
	Full: in this state, the neighboring routers are fully adjacent. These adjacencies will now appear in router-LSAs and network-LSAs.
Priority	The priority of this neighbor in the designated router election algorithm. The value 0 signifies that the neighbor is not eligible to become the designated router on this particular network.
Retrans Q Length	The current length of the retransmission queue
Options	E: external routes support
	MC: multicast support (not applicable)
	N/P: type 7 LSA support
	EA: external attribute LSA support
	DC: demand circuit support
	O: opaque LSA support

Label	Description
Backup Desig Rtr	The IP interface address of the router identified as the backup designated router for the network in which this interface is configured  Set to 0.0.0.0 if there is no backup designated router
Events	The number of times this neighbor relationship has changed state, or an error has occurred
Last Event Time	The time that the last event occurred that affected the adjacency to the neighbor
Up Time	The uninterrupted time, in hundredths of seconds, that the adjacency to this neighbor has been up. To evaluate when the last state change occurred, see last event time.
Time Before Dead	The time until this neighbor is declared down; this timer is set to the dead router interval when a valid Hello packet is received from the neighbor
Bad Nbr States	The total number of OSPF packets received when the neighbor state was not expecting to receive this packet type since this interface was last enabled
LSA Inst fails	The total number of times that an LSA could not be installed into the link-state database due to a resource allocation issue since this interface was last enabled
Bad Seq Nums	The total number of times that a database description packet was received with a sequence number mismatch since this interface was last enabled
Bad MTUs	The total number of times that the MTU in a received database description packet was larger than the MTU of the receiving interface since this interface was last enabled
Bad Packets	The total number of times that an LS update was received with an illegal LS type or an option mismatch since this interface was last enabled
LSA not in LSDB	The total number of times that an LS request was received for an LSA not installed in the LSDB of this router since this interface was last enabled
Option Mismatches	The total number of times that an LS update was received with an option mismatch since this interface was last enabled
Nbr Duplicates	The total number of times that a duplicate database description packet was received during the exchange state since this interface was last enabled



**Output example**

```
*A:7705:Dut-A# show router ospf neighbor overview
=====
Rtr Base OSPFv2 Instance 0 Neighbor (overview)
=====
Neighbor-state           Neighbors
-----
DOWN                     0
ATTEMPT                  0
INIT                     0
2WAY                     0
EXSTART                  0
EXCHANGE                 0
LOADING                  0
FULL                     0
-----
Total neighbors          0
=====
*A:7705:Dut-A# show router ospf#
```

*Table 48: Neighbor (overview) field descriptions*

Label	Description
Neighbor State	Down: the initial state of a neighbor conversation. It indicates that there has been no recent information received from the neighbor.
	Attempt: this state is only valid for neighbors attached to NBMA networks. It indicates that no recent information has been received from the neighbor, but that a more concerted effort should be made to contact the neighbor.
	Init: in this state, a Hello packet has recently been seen from the neighbor. However, bidirectional communication has not yet been established with the neighbor (that is, the router itself did not appear in the neighbor's Hello packet).
	Two Way: in this state, communication between the two routers is bidirectional
	Exchange start: the first step in creating an adjacency between the two neighboring routers. The goal of this step is to decide which router is the master, and to decide upon the initial database descriptor sequence number.
	Exchange: in this state, the router is describing its entire link-state database by sending database description packets to the neighbor
	Loading: in this state, Link-State Request packets are sent to the neighbor asking for the more recent LSAs that have been discovered (but not yet received) in the Exchange state
	Full: in this state, the neighboring routers are fully adjacent. These adjacencies will now appear in router-LSAs and network-LSAs.
Neighbors	The number of neighbors in the corresponding neighbor state

Label	Description
Total neighbors	The total number of neighbors

## opaque-database

### Syntax

**opaque-database** [**area** *area-id* | **as**] [**adv-router** *router-id*] [*ls-id*] [**detail**]

### Context

show>router>ospf

### Description

This command displays OSPF opaque database information.

### Parameters

**area** *area-id*

displays all opaque databases configured in this area

**Values** *ip-address* – a.b.c.d

*area* – 0 to 4294967295

**as**

displays opaque databases configured in the autonomous system (AS)

**adv-router** *router-id* [*ls-id*]

displays opaque database information associated with the specified advertising router. To further narrow the number of items displayed, the *ls-id* parameter can optionally be specified.

### Output

The following output is an example of OSPF opaque database information, and [Table 49: OSPF opaque database field descriptions](#) describes the fields.

### Output example

```
*A:7705:Dut-A# show router ospf opaque-database
=====
Rtr Base OSPFv2 Instance 0 Opaque Link State Database (type: All)
=====
Type  Id                Link State Id      Adv Rtr Id        Age  Sequence  Cksum
-----
Area  0.0.0.0            10.0.0.1          10.20.1.1         45   0x80000002 0xfd10
Area  0.0.0.0            10.0.0.3          10.20.1.1         648  0x80000002 0x2585
Area  0.0.0.0            10.0.0.4          10.20.1.1         603  0x80000002 0xd181
Area  0.0.0.0            10.0.0.0          10.20.1.1         242  0x80000003 0xb15d
Area  0.0.0.0            10.0.0.2          10.20.1.1         2118 0x80000002 0xb39a
Area  0.0.0.0            10.0.0.3          10.20.1.1         283  0x80000003 0x5e01
Area  0.0.0.0            10.0.0.4          10.20.1.1         579  0x80000003 0x4717
```

Area	0.0.0.0	10.0.0.1	10.20.1.3	2135	0x80000001	0x803
Area	0.0.0.0	10.0.0.3	10.20.1.3	425	0x80000002	0x5551
Area	0.0.0.0	10.0.0.4	10.20.1.3	449	0x80000002	0xbf7d
Area	0.0.0.0	10.0.0.0	10.20.1.3	2128	0x80000002	0xa766
Area	0.0.0.0	10.0.0.2	10.20.1.3	444	0x80000003	0xf551
Area	0.0.0.0	10.0.0.3	10.20.1.3	264	0x80000003	0x83aa
Area	0.0.0.0	10.0.0.4	10.20.1.3	246	0x80000003	0x6cdb
Area	0.0.0.0	10.0.0.5	10.20.1.3	561	0x80000003	0x1e3d
Area	0.0.0.0	10.0.0.1	10.20.1.4	354	0x80000002	0xafd
Area	0.0.0.0	10.0.0.3	10.20.1.4	602	0x80000003	0xdf5b
Area	0.0.0.0	10.0.0.4	10.20.1.4	580	0x80000003	0x45fa
Area	0.0.0.0	10.0.0.0	10.20.1.4	343	0x80000003	0x9f6c
Area	0.0.0.0	10.0.0.2	10.20.1.4	6	0x80000006	0x122f
Area	0.0.0.0	10.0.0.3	10.20.1.4	64	0x80000003	0xc750
Area	0.0.0.0	10.0.0.4	10.20.1.4	493	0x80000003	0x3d0e
Area	0.0.0.0	10.0.0.1	10.20.1.5	2106	0x80000001	0x10f6
Area	0.0.0.0	10.0.0.3	10.20.1.5	2088	0x80000001	0xe461
Area	0.0.0.0	10.0.0.4	10.20.1.5	2088	0x80000001	0x880f
Area	0.0.0.0	10.0.0.0	10.20.1.5	2100	0x80000002	0x9b70
Area	0.0.0.0	10.0.0.2	10.20.1.5	2089	0x80000002	0x3c06
Area	0.0.0.0	10.0.0.3	10.20.1.5	2085	0x80000002	0x4dd3
Area	0.0.0.0	10.0.0.4	10.20.1.5	2088	0x80000002	0x2923
Area	0.0.0.0	10.0.0.1	10.20.1.6	2106	0x80000001	0x14f0
Area	0.0.0.0	10.0.0.3	10.20.1.6	2089	0x80000001	0xaaeb
Area	0.0.0.0	10.0.0.0	10.20.1.6	2100	0x80000002	0x9575
Area	0.0.0.0	10.0.0.2	10.20.1.6	2089	0x80000002	0x5ee0
Area	0.0.0.0	10.0.0.3	10.20.1.6	2089	0x80000002	0xc455
Area	0.0.0.0	10.0.0.1	10.20.1.22	264	0x80000002	0x5291
Area	0.0.0.0	10.0.0.3	10.20.1.22	400	0x80000002	0xa889
Area	0.0.0.0	10.0.0.4	10.20.1.22	2116	0x80000001	0x73ca
Area	0.0.0.0	10.0.0.0	10.20.1.22	239	0x80000003	0x33c6
Area	0.0.0.0	10.0.0.2	10.20.1.22	362	0x80000003	0x74ad
Area	0.0.0.0	10.0.0.3	10.20.1.22	415	0x80000003	0x1eed
Area	0.0.0.0	10.0.0.4	10.20.1.22	390	0x80000003	0xe337
Area	0.0.0.0	10.0.0.5	10.20.1.22	2087	0x80000002	0x908a

-----  
 No. of Opaque LSAs: 42  
 =====

\*A:7705:Dut-A# show router ospf opaque-database adv-router 10.20.1.6

-----  
 Rtr Base OSPFv2 Instance 0 Opaque Link State Database (type: All)  
 =====

Type	Id	Link State Id	Adv Rtr Id	Age	Sequence	Cksum
Area	0.0.0.0	10.0.0.1	10.20.1.6	2222	0x80000001	0x14f0
Area	0.0.0.0	10.0.0.3	10.20.1.6	2204	0x80000001	0xaaeb
Area	0.0.0.0	10.0.0.0	10.20.1.6	2216	0x80000002	0x9575
Area	0.0.0.0	10.0.0.2	10.20.1.6	2204	0x80000002	0x5ee0
Area	0.0.0.0	10.0.0.3	10.20.1.6	2203	0x80000002	0xc455

-----  
 No. of Opaque LSAs: 5  
 =====

\*A:7705:Dut-A# show router ospf opaque-database adv-router 10.20.1.6 detail

-----  
 Rtr Base OSPFv2 Instance 0 Opaque Link State Database (type: All) (detail)  
 =====

-----  
 Opaque LSA  
 -----

Area Id : 0.0.0.0 Adv Router Id : 10.20.1.6

```

Link State Id   : 10.0.0.1           LSA Type       : Area Opaque
Sequence No    : 0x80000001         Checksum        : 0x14f0
Age            : 2243                Length          : 28
Options        : E
Advertisement   : Traffic Engineering
                ROUTER-ID TLV (0001) Len 4 : 10.20.1.6
-----
Opaque LSA
-----
Area Id        : 0.0.0.0             Adv Router Id   : 10.20.1.6
Link State Id  : 10.0.0.3           LSA Type       : Area Opaque
Sequence No    : 0x80000001         Checksum        : 0xaaeb
Age            : 2226                Length          : 124
Options        : E
Advertisement   : Traffic Engineering
                LINK INFO TLV (0002) Len 100 :
                Sub-TLV: 1   Len: 1   LINK_TYPE   : 2
                Sub-TLV: 2   Len: 4   LINK_ID      : 10.10.6.6
                Sub-TLV: 3   Len: 4   LOC_IP_ADDR  : 10.10.6.6
                Sub-TLV: 4   Len: 4   REM_IP_ADDR  : 10.10.10.0
                Sub-TLV: 5   Len: 4   TE_METRIC    : 100
                Sub-TLV: 6   Len: 4   MAX_BDWTH   : 10000000 Kbps
                Sub-TLV: 7   Len: 4   RSRVBL_BDWTH : 10000000 Kbps
                Sub-TLV: 8   Len: 32  UNRSRVD_CLS0 :
                P0: 10000000 Kbps P1: 10000000 Kbps P2: 10000000 Kbps P3: 10000000 Kbps
                P4: 10000000 Kbps P5: 10000000 Kbps P6: 10000000 Kbps P7: 10000000 Kbps
                Sub-TLV: 9   Len: 4   ADMIN_GROUP  : 0 None
-----
Opaque LSA
-----
Area Id        : 0.0.0.0             Adv Router Id   : 10.20.1.6
Link State Id  : 10.0.0.0           LSA Type       : Area Opaque
Sequence No    : 0x80000002         Checksum        : 0x9575
Age            : 2237                Length          : 52
Options        : E
Advertisement   : Router Info
                Capabilities (1) Len 4 :
                0x38000000
                SR algorithm (8) Len 2 :
                0x2          0x0
                SR label range (9) Len 12 :
                Range-size=10001
                Sub-TLV SID/label(1) len 3 :
                label=20000
-----
Opaque LSA
-----
Area Id        : 0.0.0.0             Adv Router Id   : 10.20.1.6
Link State Id  : 10.0.0.2           LSA Type       : Area Opaque
Sequence No    : 0x80000002         Checksum        : 0x5ee0
Age            : 2227                Length          : 44
Options        : E
Advertisement   : Extended Prefix
                TLV Extended prefix (1) Len 20 :
                rtType=1 pfxLen=32 AF=0 pfx=10.20.1.6
                Flags=Node (0x40)
                Sub-TLV Prefix SID (2) len 8 :
                Flags=noPHP (0x40)
                MT-ID=0 Algorithm=0 SID/Index/Label=1006
-----
Opaque LSA
-----
Area Id        : 0.0.0.0             Adv Router Id   : 10.20.1.6
Link State Id  : 10.0.0.3           LSA Type       : Area Opaque

```

```

Sequence No      : 0x80000002          Checksum       : 0xc455
Age              : 2226                Length        : 52
Options         : E
Advertisement    : Extended Link
  TLV Extended link (1) Len 28 :
    link Type=Transit (2) Id=10.10.6.6 Data=10.10.6.6
  Sub-TLV LAN-Adj-SID (3) len 11 :
    Flags=Value Local (0x60)
    MT-ID=0 Weight=0 Neighbor-ID=10.20.1.5
    SID/Index/Label=131071
=====
*A:7705:Dut-A#
    
```

Table 49: OSPF opaque database field descriptions

Label	Description
Area Id	A 32-bit integer uniquely identifying an area; area ID 0.0.0.0 is used for the OSPF backbone
Type	NSSA This area is configured as an NSSA area
	Area This area is configured as a standard area (not NSSA or stub)
	Stub This area is configured as a stub area
Link State Id	An LSA type-specific field containing either a router ID or an IP address; it identifies the piece of the routing domain being described by the advertisement
Adv Rtr Id	The router identifier of the router advertising the LSA
Age	The age of the link state advertisement in seconds
Sequence	The signed 32-bit integer sequence number
Cksum	The 32-bit unsigned sum of the link-state advertisements LS checksums

## prefix-sids

### Syntax

**prefix-sids** [*ip-prefix*[/*prefix-length*]] [*sid sid*] [*adv-router router-id*]

### Context

show>router>ospf

### Description

This command displays OSPF prefix SIDs information.

### Parameters

*ip-prefix[/prefix-length]*

displays information for the specified IP prefix and length, up to 64 characters

*sid*

displays information for the specific segment identifier

**Values** 0 to 524287

*router-id*

displays information for the specific advertising router identified by its router ID

### Output

The following output is an example of OSPF prefix SIDs information, and [Table 50: Prefix SIDs field descriptions](#) describes the fields.

#### Output example

```
*A:7705:Dut-A# show router ospf prefix-sids
=====
Rtr Base OSPFv2 Instance 0 Prefix-Sids
=====
Prefix                               Area          RtType        SID
Adv-Rtr                               Flags
-----
10.20.1.1/32                          0.0.0.0      INTRA-AREA   1001
                                           10.20.1.1   NnP
10.20.1.3/32                          0.0.0.0      INTRA-AREA   1003
                                           10.20.1.3   NnP
10.20.1.4/32                          0.0.0.0      INTRA-AREA   1004
                                           10.20.1.4   NnP
10.20.1.5/32                          0.0.0.0      INTRA-AREA   1005
                                           10.20.1.5   NnP
10.20.1.6/32                          0.0.0.0      INTRA-AREA   1006
                                           10.20.1.6   NnP
10.20.1.22/32                         0.0.0.0      INTRA-AREA   1002
                                           10.20.1.22  NnP
-----
No. of Prefix/SIDs: 6
SID Flags : N = Node-SID
            nP = no penultimate hop POP
            M = Mapping server
            E = Explicit-Null
            V = Prefix-SID carries a value
            L = value/index has local significance
            I = Inter Area flag
            A = Attached flag
            B = Backup flag
=====
```

```
*A:7705:Dut-A# show router ospf prefix-sids sid 1002
=====
Rtr Base OSPFv2 Instance 0 Prefix-Sids
=====
```

```

Prefix                Area          RtType    SID
                    Adv-Rtr               Flags
-----
10.20.1.22/32        0.0.0.0     INTRA-AREA 1002
                    10.20.1.22
-----
No. of Prefix/SIDs: 1
SID Flags : N = Node-SID
            nP = no penultimate hop POP
            M = Mapping server
            E = Explicit-Null
            V = Prefix-SID carries a value
            L = value/index has local significance
            I = Inter Area flag
            A = Attached flag
            B = Backup flag
=====
    
```

Table 50: Prefix SIDs field descriptions

Label	Description
Prefix	The IP prefix for the SID
Area	The OSPF area
Adv-Rtr	The advertised router IP address
RtType	The type of route
Active	The status of the route: active (Y) or inactive (N)
SID	The segment routing identifier (SID)
Flags	The flags related to the advertised router: R = Re-advertisement N = Node SID nP = No penultimate hop POP E = Explicit null V = Prefix-SID carries a value L = Value/index has local significance

## range

### Syntax

**range** [area-id]

### Context

show>router>ospf  
 show>router>ospf3

### Description

This command displays ranges of addresses on an ABR for the purpose of route summarization or suppression.

### Parameters

*area-id*

displays the configured ranges for the specified area

### Output

The following output is an example of OSPF range information, and [Table 51: Area range field descriptions](#) describes the fields.

#### Output example

```
A:ALU-A# show router ospf range
=====
Rtr Base OSPFv2 Instance 0 Ranges
=====
Area Id          Prefix          Advertise      LSDB-Type
-----
No. of Ranges: 0
=====
A:ALU-A#
```

Table 51: Area range field descriptions

Label	Description
Area Id	A 32-bit integer uniquely identifying an area; area ID 0.0.0.0 is used for the OSPF backbone
Prefix	The mask for the range expressed as a decimal integer mask length or in dotted-decimal notation
Advertise	False: the specified address/mask is not advertised outside the area
	True: the specified address/mask is advertised outside the area
LSDB-Type	NSSA: this range was specified in the NSSA context, and specifies that the range applies to external routes (via type 7 LSAs) learned within the NSSA when the routes are advertised to other areas as type 5 LSAs
	Summary: this range was not specified in the NSSA context; the range applies to summary LSAs even if the area is an NSSA



## routes

### Syntax

**routes** [*ip-prefix*[/*prefix-length*]] [*type*] [**detail**] [**alternative**] [**summary**] [**exclude-shortcut**]

**routes** [*ip-prefix*[/*px-len*]] [*type*] [**detail**] [**alternative**] [**summary**]

### Context

show>router>ospf

show>router>ospf3

### Description

This command displays information about OSPF routes.

### Parameters

*ip-prefix/prefix-length*

displays information for the specified IP address and prefix length

*ip-prefix/px-len*

displays information for the specified IP address and prefix length. This parameter applies only in the **ospf3** context.

*type*

displays information for the specified route type

**Values** intra-area, inter-area, external-1, external-2, nssa-1, nssa-2

**detail**

displays detailed information for the routes

**alternative**

displays the level of protection per prefix

**summary**

displays summary information for the routes

**exclude-shortcut**

displays routes without shortcuts

### Output

The following outputs are examples of OSPF route information.

#### Output example

```
A:ALU-A# show router ospf routes
=====
Rtr Base OSPFv2 Instance 0 Route Table
=====
Destination          Type(Dest)  Stat      SID   SIDflgs
  NHIP              NHIF      Cost[E2]
-----
```

```

10.1.1.1/32      IA (HOST)      N (R)
  10.1.3.1      3          1000
10.1.2.0/24     IA (NET)      N (R)
  10.1.3.1      3          2000
  10.2.3.2      4          2000
10.1.3.0/24     IA (NET)      D (F)
  DIRECT       3          1000
10.2.3.0/24     IA (NET)      D (F)
  DIRECT       4          1000
10.2.4.0/24     IA (NET)      N (R)
  10.2.3.2      5          2000
10.3.5.0/24     IA (NET)      D (F)
  DIRECT       6          1000
10.4.5.0/24     IA (NET)      N (R)
  10.3.5.5      6          2000
10.4.6.0/24     IE (NET)      N (R)
  10.2.3.2      5          3000
  10.3.5.5      6          3000
10.5.6.0/24     IE (NET)      N (R)
  10.3.5.5      6          2000
10.2.2.2/32     IA (HOST)      N (R)
  10.2.3.2      5          1000
10.2.3.0/24     IA (NET)      D (F)
  DIRECT 5      1000
10.3.3.3/32     IA (HOST)      D (F)
  DIRECT       2          0
10.4.4.4/32     IA (HOST)      N (R)
  10.2.3.2      5          2000
  10.3.5.5      6          2000
10.5.5.5/32     IA (HOST)      N (R)
  1.3.5.5       6          1000
10.6.6.6/32     IE (HOST)      N (R)
  10.3.5.5      6          2000
10.20.1.1/32    IA (HOST)      N (R)    11    NnP
  10.1.3.1      3          1000
10.20.1.2/32    IA (HOST)      N (R)    22    NnP
  10.2.3.2      5          1000
10.20.1.3/32    IA (HOST)      D (F)    33    NnP
  DIRECT       1          0
10.20.1.4/32    IA (HOST)      N (R)    44    NnP
  10.2.3.2      5          2000
  10.3.5.5      6          2000
10.20.1.5/32    IA (HOST)      N (R)    55    NnP
  10.3.5.5      6          1000
10.20.1.6/32    IE (HOST)      N (R)    66    NnP
  10.3.5.5      6          2000
10.20.1.1/0     IA (RTR)       N (N)
  10.1.3.1      3          1000
10.20.1.2/0     IA (AB-AS)     N (N)
  10.2.3.2      5          1000
10.20.1.2/0     IA (AB-AS)     N (N)
  10.2.3.2      4          1000
10.20.1.4/0     IA (AB-AS)     N (N)
  10.2.3.2      5          2000
  10.3.5.5      6          2000
10.20.1.5/0     IA (AB-AS)     N (N)
  10.3.5.5      6          1000

```

```

-----
No. of routes found: 26 (31 paths)
Stat: D = direct  N = not direct
(RTM stat):(R) = added      (F) = add failed
          (N) = not added  (D) = policy discarded
SID Flags : N = Node-SID
          nP = no penultimate hop POP

```

M = Mapping server  
 E = Explicit-Null  
 V = Prefix-SID carries a value  
 L = value/index has local significance  
 I = Inter Area flag  
 A = Attached flag

=====  
 A:ALU-A#

A:ALU-A# show router ospf routes alternative detail

=====  
 Rtr Base OSPFv2 Instance 0 Routing Table (alternative) (detail)  
 =====

Destination	Type(Dest)	Stat			Tunnel-Information
NHIP	NHIF	Cost[E2]	Area		PGID
A-NHIP(L)	A-NHIF	A-Cost[E2]	A-Type		
-----					
10.1.2.0/24	IA (NET)	D (F)			
DIRECT	2	10	0.0.0.0		
10.1.3.0/24	IA (NET)	D (F)			
DIRECT	3	10	0.0.0.0		
10.2.3.0/24	IA (NET)	N (R)			
10.1.2.2	2	20	0.0.0.0		
10.1.3.3	3	20	0.0.0.0		
10.2.4.0/24	IA (NET)	N (R)			
10.1.2.2	2	20	0.0.0.0		
10.1.3.3(L)	3	30	LINK		0x130015
10.3.5.0/24	IA (NET)	N (R)			
10.1.3.3	3	20	0.0.0.0		
10.1.2.2(L)	2	30	LINK		0x130016
10.4.5.0/24	IA (NET)	N (R)			
10.1.2.2	2	30	0.0.0.0		
10.1.3.3	3	30	0.0.0.0		
10.4.6.0/24	IA (NET)	N (R)			
10.1.2.2	2	30	0.0.0.0		
10.1.3.3(L)	3	40	LINK		0x130015
10.5.6.0/24	IA (NET)	N (R)			
10.1.3.3	3	30	0.0.0.0		
10.1.2.2(L)	2	40	LINK		0x130016
10.20.1.1/32	IA (HOST)	D (F)			
DIRECT	1	0	0.0.0.0		
10.20.1.2/32	IA (HOST)	N (R)			
10.1.2.2	2	10	0.0.0.0		
10.1.3.3(L)	3	20	LINK		0x130015
10.20.1.3/32	IA (HOST)	N (R)			
10.1.3.3	3	10	0.0.0.0		
10.1.2.2(L)	2	20	LINK		0x130016
10.20.1.4/32	IA (HOST)	N (R)			
10.1.2.2	2	20	0.0.0.0		
10.1.3.3(L)	3	30	LINK		0x130015
10.20.1.5/32	IA (HOST)	N (R)			
1.1.3.3	3	20	0.0.0.0		
1.1.2.2(L)	2	30	LINK		0x130016
10.20.1.6/32	IA (HOST)	N (R)			
10.1.3.3	3	30	0.0.0.0		
10.1.2.2	2	30	0.0.0.0		
10.20.1.2/0	IA (RTR)	N (N)			
10.1.2.2	2	10	0.0.0.0		
10.20.1.3/0	IA (RTR)	N (N)			
10.1.3.3	3	10	0.0.0.0		
10.20.1.4/0	IA (RTR)	N (N)			
10.1.2.2	2	20	0.0.0.0		
10.20.1.5/0	IA (RTR)	N (N)			

```

10.1.3.3      3      20      0.0.0.0
10.20.1.6/0  IA (RTR)  N (N)
10.1.3.3      3      30      0.0.0.0
10.1.2.2      2      30      0.0.0.0
-----

```

```

19 OSPFv2 routes found (23 paths)
Flags: L = Loop-Free Alternate nexthop
Stat: D = direct  N = not direct
(RTM stat):(R) = added      (F) = add failed
           (N) = not added  (D) = policy discarded
=====
A:ALU-A#

```

## sham-link

### Syntax

```
sham-link [interface-name] [detail]
```

```
sham-link interface-name remote ip-address [detail]
```

### Context

```
show>router>ospf
```

### Description

This command displays OSPF sham-link information.

### Parameters

*interface-name*

displays only the sham-link information for the specified interface name, up to 32 characters

*ip-address*

displays only the sham-link information for the specified remote neighbor IP address, in the format a.b.c.d

**detail**

displays detailed OSPF sham-link information

### Output

The following outputs are examples of OSPF sham-link information:

- OSPF sham-link standard information ([Output example](#), [Table 52: OSPF sham link field descriptions \(standard\)](#))
- OSPF sham-link detailed information ([Output example](#), [Table 53: OSPF sham link field descriptions \(detailed\)](#))

### Output example

```
*A:7705:Dut-C# show router 1000 ospf sham-link
```

```
=====
Rtr vprn1000 OSPFv2 Instance 0 Sham-Links
=====
```

```

If Name                Nbr IP                Metric Adm Oper
-----
myLocalShamItf        50.0.0.2              1    Up  PToP
-----
No. of OSPF Sham-links: 1
=====
*A:7705:Dut-C#
    
```

Table 52: OSPF sham link field descriptions (standard)

Label	Description
If Name	The interface name
Nbr IP	The remote neighbor IP address
Metric	The route cost metric for the sham link
Adm	Dn: OSPF on this sham link is administratively shut down
	Up: OSPF on this sham link is administratively enabled
Oper	Down: the initial interface state. In this state, the lower-level protocols have indicated that the interface is unusable.
	Wait: the router is trying to determine the identity of the (backup) designated router for the network
	PToP: the interface is operational and connects either to a physical point-to-point network, a virtual link, or sham link
	DR: this router is the designated router for this network
	BDR: this router is the backup designated router for this network
	ODR: the interface is operational and part of a broadcast or NBMA network on which another router has been selected to be the designated router
No. of OSPF Sham-links	The total number of listed sham links

**Output example**

```

*A:7705:Dut-C# show router 1000 ospf sham-link detail
=====
Rtr vprn1000 OSPFv2 Instance 0 Sham-Links (detail)
=====
Interface: myLocalShamItf Remote Nbr: 50.0.0.2
-----
Local IP Address : 50.0.0.1
Area Id          : 0.0.0.0
Admin Status     : Enabled
Transit Delay    : 1 sec
Hello Intrvl     : 10 sec
Cfg Metric       : 1
Last Enabled     : 02/24/2021 17:48:22
Oper State       : Point To Point
Retrans Intrvl  : 5 sec
Rtr Dead Intrvl : 40 sec
Auth Type        : None
    
```

```

If Events      : 1
Tot Rx Packets : 44
Rx Hellos     : 15
Rx DBDs      : 2
Rx LSRs      : 1
Rx LSUs      : 15
Rx LS Acks   : 11
Retransmits  : 0
Bad Networks : 0
Bad Areas    : 0
Bad Auth Types : 0
Bad Neighbors : 0
Bad Lengths  : 0
Bad Dead Int. : 0
Bad Versions  : 0

Tot Tx Packets : 47
Tx Hellos     : 15
Tx DBDs      : 3
Tx LSRs      : 1
Tx LSUs      : 15
Tx LS Acks   : 13
Discards     : 0

Bad Dest Addr : 0
Auth Failures : 0
Bad Pkt Types : 0
Bad Hello Int. : 0
Bad Options   : 0
Bad Checksums : 0
    
```

=====  
 \*A:7705:Dut-C#

Table 53: OSPF sham link field descriptions (detailed)

Label	Description
Interface	The interface name
Remote Nbr	The remote neighbor IP address
Local IP Address	The IP address assigned the local end of the interface
Area Id	A 32-bit integer uniquely identifying the area to which this interface is connected; area ID 0.0.0.0 is used for the OSPF backbone
Last Enabled	The date and time that this interface was last enabled to run OSPF
Admin Status	Disabled: OSPF on this interface is administratively shut down
	Enabled: OSPF on this interface is administratively enabled
Oper State	Down: the initial interface state. In this state, the lower-level protocols have indicated that the interface is unusable.
	Waiting: the router is trying to determine the identity of the (backup) designated router for the network
	Point To Point: the interface is operational and connects either to a physical point-to-point network, virtual link, or sham link
	Designated Rtr: this router is the designated router for this network
	Other Desig Rtr: the interface is operational and part of a broadcast or NBMA network on which another router has been selected to be the designated router

Label	Description
	Backup Desig Rtr: this router is the backup designated router for this network
Transit Delay	The estimated number of seconds it takes to transmit a link-state update packet over this interface
Retrans Intrvl	The number of seconds between link-state advertisement retransmissions for adjacencies belonging to this interface. This value is also used when retransmitting database description and link-state request packets.
Hello Intrvl	The number of seconds between the Hello packets that the router sends on this interface. This value must be the same for all routers attached to a common network.
Rtr Dead Intrvl	The number of seconds that Hello packets have not been transmitted by a router before its neighbors declare the router down. This value should be a multiple of the Hello interval. This value must be the same for all routers attached to a common network.
Cfg Metric	The route cost metric to be advertised for this interface
Auth Type	Identifies the authentication procedure to be used for OSPF packets
	None: routing exchanges over the network/subnet are not authenticated
	Simple: a 64-bit field is configured on a per-network basis. All packets sent on a particular network must have this configured value in their OSPF header 64-bit authentication field. This essentially serves as a "clear" 64-bit password.
	MD5: a shared secret key is configured on all routers attached to a common network or subnet. For each OSPF protocol packet, the key is used to generate and verify a "message digest" that is appended to the end of the OSPF packet.
If Events	The number of times this interface has changed its state, or an error has occurred since the interface was last enabled
Tot Rx Packets	The total number of OSPF packets received on this interface since the interface was last enabled
Tot Tx Packets	The total number of OSPF packets transmitted on this interface since the interface was last enabled
Rx Hellos	The total number of OSPF Hello packets received on this interface since the interface was last enabled

Label	Description
Tx Hellos	The total number of OSPF Hello packets transmitted on this interface since the interface was last enabled
Rx DBDs	The total number of OSPF database description packets received on this interface since the interface was last enabled
Tx DBDs	The total number of OSPF database description packets transmitted on this interface since the interface was last enabled
Rx LSRs	The total number of Link-State Requests (LSRs) received on this interface since the interface was last enabled
Tx LSRs	The total number of Link-State Requests (LSRs) transmitted on this interface since the interface was last enabled
Rx LSUs	The total number of Link-State Updates (LSUs) received on this interface since the interface was last enabled
Tx LSUs	The total number of Link-State Updates (LSUs) transmitted on this interface since the interface was last enabled
Rx LS Acks	The total number of Link-State Acknowledgments received on this interface since the interface was last enabled
Tx LS Acks	The total number of Link-State Acknowledgments transmitted on this interface since the interface was last enabled
Retransmits	The total number of OSPF retransmits sent on this interface since the interface was last enabled
Discards	The total number of OSPF packets discarded on this interface since the interface was last enabled
Bad Networks	The total number of OSPF packets received with invalid network or mask since the interface was last enabled
Bad Areas	The total number of OSPF packets received with an area mismatch since this interface was last enabled
Bad Dest Addr	The total number of OSPF packets received with the incorrect IP destination address since this interface was last enabled
Bad Auth Types	The total number of OSPF packets received with an invalid authorization type since this interface was last enabled
Auth Failures	The total number of OSPF packets received with an invalid authorization key since this interface was last enabled
Bad Neighbors	The total number of OSPF packets received where the neighbor information does not match the information this router has for the neighbor since this interface was last enabled



Label	Description
Bad Pkt Types	The total number of OSPF packets received with an invalid OSPF packet type since this interface was last enabled
Bad Lengths	The total number of OSPF packets received on this interface with a total length not equal to the length given in the packet since the interface was last enabled
Bad Hello Int.	The total number of OSPF packets received where the hello interval given in the packet is not equal to that configured on this interface since the interface was last enabled
Bad Dead Int.	The total number of OSPF packets received where the dead interval given in the packet is not equal to that configured on this interface since the interface was last enabled
Bad Options	The total number of OSPF packets received with an option that does not match those configured for this interface or area since the interface was last enabled
Bad Versions	The total number of OSPF packets received with bad OSPF version numbers since this interface was last enabled
Bad Checksums	The total number of OSPF packets received with bad checksums since this interface was last enabled

## sham-link-neighbor

### Syntax

**sham-link-neighbor** [**detail**]

**sham-link-neighbor** *interface-name* **remote** *ip-address* [**detail**]

### Context

show>router>ospf

### Description

This command displays OSPF sham-link neighbor information.

### Parameters

*interface-name*

displays only the sham-link neighbor information for the specified interface name, up to 32 characters

*ip-address*

displays only the sham-link neighbor information for the specified remote neighbor IP address, in the format a.b.c.d

**detail**

displays detailed OSPF sham-link neighbor information

**Output**

The following output is an example of sham-link neighbor information:

- OSPF sham-link standard information ([Output example, Table 54: OSPF sham-link neighbor field descriptions \(standard\)](#))
- OSPF sham-link detailed information ([Output example, Table 55: OSPF sham-link neighbor field descriptions \(detailed\)](#))

**Output example**

```
*A:7705:Dut-C# show router 1000 ospf sham-link-neighbor
=====
Rtr vprn1000 OSPFv2 Instance 0 Sham-Link Neighbors
=====
Interface Name           Neighbor IP      State    RetxQ   DeadTime
-----
myLocalShamItf          50.0.0.2       Full     0       31
-----
No. of Neighbors: 1
=====
*A:7705:Dut-C#
```

Table 54: OSPF sham-link neighbor field descriptions (standard)

Label	Description
Interface Name	The interface name
Neighbor IP	The remote neighbor IP address
State	Down: the initial state of a neighbor conversation. It indicates that there has been no recent information received from the neighbor.
	Attempt: this state is only valid for neighbors attached to NBMA networks. It indicates that no recent information has been received from the neighbor but that a more concerted effort should be made to contact the neighbor.
	Init: in this state, a Hello packet has recently been received from the neighbor. However, bidirectional communication has not yet been established with the neighbor (that is, the router did not appear in the neighbor's Hello packet).
	Two Way: in this state, communication between the two routers is bidirectional
	ExchStart: the first step in creating an adjacency between the two neighboring routers. The goal of this step is to decide which

Label	Description
	router is the master and to decide upon the initial database descriptor sequence number.
	Exchange: in this state, the router is describing its entire link-state database by sending database description packets to the neighbor
	Loading: in this state, Link-State Request packets are sent to the neighbor asking for the more recent LSAs that have been discovered (but not yet received) in the Exchange state
	Full: in this state, the neighboring routers are fully adjacent. These adjacencies will now appear in router LSAs and network LSAs.
RetxQ	The current length of the retransmission queue
DeadTime	The time until this neighbor is declared down
No. of Neighbors	The number of adjacent OSPF neighbors on this interface

**Output example**

```
*A:7705:Dut-C# show router 1000 ospf sham-link-neighbor detail
=====
Rtr vprn1000 OSPFv2 Instance 0 Sham-Link Neighbors (detail)
=====
-----
Interface: myLocalShamItf Remote Nbr : 50.0.0.2
-----
Area Id : 0.0.0.0
Neighbor State : Full Options : -E-- -0--
Last Event Time : 02/24/2021 17:48:22 Last Restart at : Never
Up Time : 0d 00:02:22 Time Before Dead : 37 sec
GR Helper : Not Helping GR Helper Age : 0 sec
GR Exit Reason : None GR Restart Reason: Unknown
Retrans Q Length : 0 Events : 5
Bad Nbr States : 0 LSA Inst fails : 0
Bad Seq Nums : 0 Bad MTUs : 0
Bad Packets : 0 LSA not in LSDB : 0
Option Mismatches: 0 Nbr Duplicates : 0
Num Restarts : 0
=====
*A:7705:Dut-C#
```

Table 55: OSPF sham-link neighbor field descriptions (detailed)

Label	Description
Interface	The interface name
Remote Nbr	The remote neighbor IP address

Label	Description
Area Id	A 32-bit integer uniquely identifying the area to which this interface is connected; area ID 0.0.0.0 is used for the OSPF backbone
Neighbor State	Down: the initial state of a neighbor conversation. It indicates that there has been no recent information received from the neighbor.
	Attempt: this state is only valid for neighbors attached to NBMA networks. It indicates that no recent information has been received from the neighbor, but that a more concerted effort should be made to contact the neighbor.
	Init: in this state, a Hello packet has recently been received from the neighbor. However, bidirectional communication has not yet been established with the neighbor (that is, the router did not appear in the neighbor's Hello packet).
	Two Way: in this state, communication between the two routers is bidirectional
	ExchStart: the first step in creating an adjacency between the two neighboring routers. The goal of this step is to decide which router is the master and to decide upon the initial database descriptor sequence number.
	Exchange: in this state, the router is describing its entire link-state database by sending database description packets to the neighbor
	Loading: in this state, Link-State Request packets are sent to the neighbor asking for the more recent LSAs that have been discovered (but not yet received) in the Exchange state
	Full: in this state, the neighboring routers are fully adjacent. These adjacencies will now appear in router LSAs and network LSAs.
Options	E: external routes support
	MC: multicast support (not applicable)
	N/P: type 7 LSA support
	EA: external attribute LSA support
	DC: demand circuit support
	O: opaque LSA support
Last Event Time	The time that the last event occurred that affected the adjacency to the neighbor

Label	Description
Last Restart at	The local time of the last graceful restart
Up Time	The uninterrupted length of time that the adjacency to this neighbor has been up. The Last Event Time field shows when the last state change occurred.
Time Before Dead	The time until this neighbor is declared down; this timer is set to the dead router interval when a valid Hello packet is received from the neighbor
GR Helper	Graceful restart helper mode, either Helping or Not Helping
GR Helper Age	The time elapsed since GR Helper was enabled
GR Exit Reason	The reason for a graceful restart exit
GR Restart Reason	The reason for a graceful restart
Retrans Q Length	The current length of the retransmission queue
Events	The number of times this neighbor relationship has changed state, or an error has occurred
Bad Nbr States	The total number of OSPF packets received when the neighbor state was not expecting to receive this packet type since this interface was last enabled
LSA Inst fails	The total number of times that an LSA could not be installed into the link-state database due to a resource allocation issue since this interface was last enabled
Bad Seq Nums	The total number of times that a database description packet was received with a sequence number mismatch since this interface was last enabled
Bad MTUs	The total number of times that the MTU in a received database description packet was larger than the MTU of the receiving interface since this interface was last enabled
Bad Packets	The total number of times that an LS update was received with an illegal LS type or an option mismatch since this interface was last enabled
LSA not in LSDB	The total number of times that an LS request was received for an LSA not installed in the LSDB of this router since this interface was last enabled
Option Mismatches	The total number of times that an LS update was received with an option mismatch since this interface was last enabled

Label	Description
Nbr Duplicates	The total number of times that a duplicate database description packet was received during the exchange state since this interface was last enabled
Num Restarts	The total number of graceful restarts

## spf

### Syntax

**spf** [*lfa*]

### Context

show>router>ospf

show>router>ospf3

### Description

This command displays statistics of shortest path first (SPF) calculations.

### Parameters

**lfa**

displays LFA next hop information

### Output

The following output is an example of SPF information, and [Table 56: SPF field descriptions](#) describes the fields.

### Output example

```
A:ALU-A# show router ospf spf lfa
=====
Rtr Base OSPFv2 Instance 0 SPF Statistics
=====
Total SPF Runs           : 109
Last Full SPF run @     : 11/07/2015 18:43:07
Last Full SPF Time      : < 0.01 secs
  Intra SPF Time        : < 0.01 secs
  Inter SPF Time        : < 0.01 secs
  Extern SPF Time       : < 0.01 secs
  RTM Updt Time        : < 0.01 secs

Min/Avg/Max Full SPF Times : 0.02/0.00/0.06 secs
Min/Avg/Max RTM Updt Times : 0.02/0.00/0.06 secs

Total Sum Incr SPF Runs : 333

Total Ext Incr SPF Runs : 0

Total LFA SPF Runs      : 5
Last LFA SPF run @     : 11/07/2015 18:43:07
```

```
Last LFA SPF Time      : < 0.01 secs
Min/Avg/Max LFA  SPF Times : 0.00/0.00/0.00 secs
=====
```

Table 56: SPF field descriptions

Label	Description
Total SPF Runs	The total number of incremental SPF runs triggered by new or updated LSAs
Last Full SPF run @	The date and time that the external OSPF SPF was last run
Last Full SPF Time	The length of time, in seconds, when the last full SPF was run
Intra SPF Time	The time that intra-area SPF was last run on this area
Inter SPF Time	The total number of incremental SPF runs triggered by new or updated type 3 and type 4 summary LSAs
Extern SPF Time	The total number of incremental SPF runs triggered by new or updated type 5 external LSAs
RTM Updt Time	The time, in hundredths of seconds, used to perform a total SPF calculation
Min/Avg/Max Full SPF Times	Min: the minimum time, in hundredths of seconds, used to perform a total SPF calculation
	Avg: the average time, in hundredths of seconds, of all the SPF calculations performed by this OSPF router
	Max: the maximum time, in hundredths of seconds, used to perform a total SPF calculation
Min/Avg/Max RTM Updt Times	Min: the minimum time, in hundredths of seconds, used to perform an RTM update  Note: the RTM update is performed after the SPF calculation. The update is used to inform the routing table manager of any route or cost changes from the latest SPF calculation.
	Avg: the average time, in hundredths of seconds, of all the RTM updates performed by this OSPF router
	Max: the maximum time, in hundredths of seconds, used to perform an RTM update
Total Sum Incr SPF Runs	The total number of incremental SPF runs triggered by new or updated type 3 and type 4 summary LSAs
Total Ext Incr SPF Runs	The total number of incremental SPF runs triggered by new or updated type 5 external LSAs

Label	Description
Total LFA SPF Runs	The total number of incremental LFA SPF runs triggered by new or updated LSAs
Last LFA SPF run @	The date and time that the external OSPF LFA SPF was last run
Last LFA SPF Time	The length of time, in seconds, when the last LFA SPF was run
Min/Avg/Max LFA SPF Times	Min: the minimum time, in hundredths of seconds, used to perform an LFA SPF calculation
	Avg: the average time, in hundredths of seconds, of all the LFA SPF calculations performed by this OSPF router
	Max: the maximum time, in hundredths of seconds, used to perform an LFA SPF calculation

## statistics

### Syntax

**statistics**

### Context

show>router>ospf  
show>router>ospf3

### Description

This command displays the global OSPF statistics.

### Output

The following output is an example of OSPF statistical information, and [Table 57: OSPF statistics field descriptions](#) describes the fields.

### Output example

```
A:ALU-A# show router ospf statistics
=====
Rtr Base OSPFv2 Instance 0 Statistics
=====
Rx Packets      : 308462          Tx Packets      : 246800
Rx Hellos       : 173796          Tx Hellos       : 149062
Rx DBDs         : 67             Tx DBDs         : 48
Rx LSRs         : 21             Tx LSRs         : 19
Rx LSUs         : 105672         Tx LSUs         : 65530
Rx LS Acks      : 28906          Tx LS Acks      : 32141
New LSAs Recvd  : 38113           New LSAs Orig   : 21067
Ext LSAs Count  : 17             No of Areas     : 3
No of Interfaces : 327           No of Neighbors : 0
Retransmits     : 46             Discards        : 0
Bad Networks    : 0             Bad Virt Links  : 0
```



```

Bad Areas          : 0          Bad Dest Adrs      : 0
Bad Auth Types    : 0          Auth Failures     : 0
Bad Neighbors     : 0          Bad Pkt Types     : 0
Bad Lengths       : 0          Bad Hello Int.    : 0
Bad Dead Int.     : 0          Bad Options       : 0
Bad Versions      : 0          Bad Checksums     : 0
SID SRGB errors   : 0          SID dupl errors   : 0
Failed SPF Attempts: 0        Bad MTUs          : 0
CSPF Requests     : 0          CSPF Request Drops: 0
CSPF Path Found   : 0          CSPF Path Not Found: 0
Total SPF Runs    : 1          Total LFA SPF Runs: 1
Total RLFA SPF Runs: 0
=====
    
```

Table 57: OSPF statistics field descriptions

Label	Description
Rx Packets	The total number of OSPF packets received on all OSPF enabled interfaces
Tx Packets	The total number of OSPF packets transmitted on all OSPF enabled interfaces
Rx Hellos	The total number of OSPF Hello packets received on all OSPF enabled interfaces
Tx Hellos	The total number of OSPF Hello packets transmitted on all OSPF enabled interfaces
Rx DBDs	The total number of OSPF database description packets received on all OSPF enabled interfaces
Tx DBDs	The total number of OSPF database description packets transmitted on all OSPF enabled interfaces
Rx LSRs	The total number of OSPF Link-State Requests (LSRs) received on all OSPF enabled interfaces
Tx LSRs	The total number of OSPF Link-State Requests (LSRs) transmitted on all OSPF enabled interfaces
Rx LSUs	The total number of OSPF Link-State Updates (LSUs) received on all OSPF enabled interfaces
Tx LSUs	The total number of OSPF Link-State Updates (LSUs) transmitted on all OSPF enabled interfaces
Rx LS Acks	The total number of OSPF Link-State Acknowledgments received on all OSPF enabled interfaces
New LSAs Recvd	The total number of new OSPF Link-State Advertisements received on all OSPF enabled interfaces
New LSAs Orig	The total number of new OSPF Link-State Advertisements originated on all OSPF enabled interfaces

Label	Description
Ext LSAs Count	The total number of OSPF External Link-State Advertisements
No of Areas	The number of areas configured for OSPF (maximum 4)
No of Interfaces	The number of interfaces configured for OSPF on the router
No of Neighbors	The number of adjacent OSPF neighbors on this interface
Retransmits	The total number of OSPF Retransmits transmitted on all OSPF enabled interfaces
Discards	The total number of OSPF packets discarded on all OSPF enabled interfaces
Bad Networks	The total number of OSPF packets received on all OSPF enabled interfaces with invalid network or mask
Bad Virt Links	The total number of OSPF packets received on all OSPF enabled interfaces that are destined for a virtual link that does not exist
Bad Areas	The total number of OSPF packets received on all OSPF enabled interfaces with an area mismatch
Bad Dest Addr	The total number of OSPF packets received on all OSPF enabled interfaces with the incorrect IP destination address
Bad Auth Types	The total number of OSPF packets received on all OSPF enabled interfaces with an invalid authorization type
Auth Failures	The total number of OSPF packets received on all OSPF enabled interfaces with an invalid authorization key
Bad Neighbors	The total number of OSPF packets received on all OSPF enabled interfaces where the neighbor information does not match the information this router has for the neighbor
Bad Pkt Types	The total number of OSPF packets received on all OSPF enabled interfaces with an invalid OSPF packet type
Bad Lengths	The total number of OSPF packets received on all OSPF enabled interfaces with a total length not equal to the length given in the packet itself
Bad Hello Int.	The total number of OSPF packets received on all OSPF enabled interfaces where the hello interval given in the packet was not equal to that configured for the respective interface
Bad Dead Int.	The total number of OSPF packets received on all OSPF enabled interfaces where the dead interval given in the packet was not equal to that configured for the respective interface

Label	Description
Bad Options	The total number of OSPF packets received on all OSPF enabled interfaces with an option that does not match those configured for the respective interface or area
Bad Versions	The total number of OSPF packets received on all OSPF enabled interfaces with bad OSPF version numbers
Bad Checksums	The total number of OSPF packets received with bad checksums since this interface was last enabled
SID SRGB errors	The total number of SID SRGB errors
SID dupl errors	The total number of SID duplication errors
Failed SPF Attempts	The total number of failed SPF calculation attempts
Bad MTUs	The total number of MTU mismatch
CSPF Requests	The total number of constraint-based SPF requests
CSPF Request Drops	The total number of constraint-based SPF requests dropped
CSPF Path Found	A path that fulfills the set of constraints defined in MPLS traffic engineering
CSPF Path Not Found	A path that does not fulfill the set of constraints defined in MPLS traffic engineering
Total SPF Runs	The total number of incremental SPF runs triggered by new or updated LSAs
Total LFA SPF Runs	The total number of incremental LFA SPF runs triggered by new or updated LSAs

## status

### Syntax

**status**

### Context

show>router>ospf

show>router>ospf3

### Description

This command displays the general status of OSPF.

## Output

The following output is an example of OSPF status information, and [Table 58: OSPF status field descriptions](#) describes the fields.

### Output example

```
A:ALU-A# show router ospf status
=====
Rtr Base OSPFv2 Instance 0 Status
=====
OSPF Cfg Router Id       : 10.0.0.0
OSPF Oper Router Id     : 10.10.10.104
OSPF Version            : 2
OSPF Admin Status       : Enabled
OSPF Oper Status        : Enabled
GR Helper Mode          : Enabled
Preference              : 10
External Preference     : 150
Backbone Router         : True
Area Border Router      : False
AS Border Router        : False
Opaque LSA Support      : True
Traffic Engineering Support : False
RFC 1583 Compatible     : True
Demand Exts Support     : False
In Overload State       : False
In External Overflow State : False
Exit Overflow Interval  : 0
Last Overflow Entered   : Never
Last Overflow Exit      : Never
External LSA Limit      : -1
Reference Bandwidth     : 100,000,000 Kbps
Init SPF Delay          : 1000 msec
Sec SPF Delay           : 1000 msec
Max SPF Delay           : 10000 msec
Min LS Arrival Interval : 1000 msec
Init LSA Gen Delay      : 5000 msec
Sec LSA Gen Delay       : 5000 msec
Max LSA Gen Delay       : 5000 msec
Last Ext SPF Run        : Never
Ext LSA Cksum Sum       : 0x0
OSPF Last Enabled      : 01/12/2015 15:32:11
Unicast Import          : True
Export Policies         : None
Import Policies         : None
Lfa Policies            : pol1
                       : pol2
                       : pol3
                       : pol4
                       : pol5
OSPF Ldp Sync Admin Status : Enabled
LDP-over-RSVP          : Disabled
RSVP-Shortcut          : Enabled
Advertise-Tunnel-Link  : Disabled
LFA                    : Enabled
Remote-LFA             : Enabled
Max PQ Cost            : 65535
TI-LFA                 : Disabled
Max SR FRR Labels      : 2
Export Limit           : 0
Export Limit Log Percent : 0
Total Exp Routes       : 0
Segment Routing        : Disabled
```

```

Database export      : Disabled
ASN                 : n/a
Entropy Label       : Enabled
Override ELC        : Disabled
=====
A:ALU-A#
    
```

Table 58: OSPF status field descriptions

Label	Description
OSPF Cfg Router Id	The router ID configured for the router
OSPF Oper Router ID	The operational router ID. The 7705 SAR defaults to the system IP address or, if not configured, the last 4 bytes of the system MAC address.
OSPF Version	The current version number of the OSPF protocol: 2
OSPF Admin Status	Disabled: the OSPF process is disabled on all interfaces
	Enabled: the OSPF process is active on at least one interface
OSPF Oper Status	Disabled: the OSPF process is not operational on all interfaces
	Enabled: the OSPF process is operational on at least one interface
GR Helper Mode	Disabled: graceful restart helper is disabled
	Enabled: graceful restart helper is enabled
Preference	The route preference for OSPF internal routes
External Preference	The route preference for OSPF external routes
Backbone Router	False: this router is not configured as an OSPF backbone router
	True: this router is configured as an OSPF backbone router
Area Border Router	False: this router is not configured as an area border router
	True: this router is configured as an area border router
AS Border Router	False: this router is not configured as an autonomous system border (boundary) router
	True: this router is configured as an autonomous system border (boundary) router
Opaque LSA Support	False: this router does not support opaque LSAs
	True: this router supports opaque LSAs
Traffic Engineering Support	False: this router does not support traffic engineering

Label	Description
	True: this router supports traffic engineering
RFC 1583 Compatible	False: this router is not RFC 1583 compatible
	True: this router is RFC 1583 compatible
Demand Exts Support	False: this router does not demand external route support
	True: this router does demand external route support
In Overload State	False: this router is not in an overload state
	True: this router is in an overload state
In External Overflow State	False: this router is not in an external overflow state
	True: this router is in an external overflow state
Exit Overflow Interval	The time to wait before the router exits the overflow state
Last Overflow Entered	Indicates when the router last entered an overflow state
Last Overflow Exit	Indicates when the router last exited an overflow state
External LSA limit	The number of external LSAs allowed
Reference bandwidth	The configured reference bandwidth, in kilobits per second
Init SPF Delay	The initial SPF calculation delay
Sec SPF Delay	The SPF calculation delay between the first and second calculations
Max SPF Delay	The maximum interval between two consecutive SPF calculations
Min LS Arrival Interval	The minimum interval between LSAs
Init LSA Gen Delay	The initial LSA generation delay
Sec LSA Gen Delay	The delay between the generation of the first and second LSAs
Max LSA Gen Delay	The maximum interval between two consecutive LSAs
Last Ext SPF Run	The time that the last external SPF calculation was run
Ext LSA Cksum Sum	The 32-bit unsigned sum of the LS checksums of the external LSAs contained in this area's link-state database
OSPF Last Enabled	The time that OSPF was last enabled on the interface
Unicast Import	Indicates whether routes are imported into the unicast RTM
Export Policies	Indicates whether any export routing policies have been applied to the OSPF interface

Label	Description
Import Policies	Indicates whether any import routing policies have been applied to the OSPF interface
Lfa Policies	Lists the defined LFA policies
OSPF Ldp Sync Admin Status	Indicates whether the IGP-LDP synchronization feature is enabled or disabled on all interfaces participating in the OSPF routing protocol
RSVP-Shortcut	Indicates whether RSVP-TE shortcuts (IGP shortcuts) are enabled
Advertise-Tunnel-Link	Indicates whether forwarding adjacencies are enabled
LFA	Indicates whether LFA is enabled
Remote-LFA	Indicates whether LFA is enabled on the remote device
Max PQ Cost	Indicates the configured maximum PQ cost under the <b>loopfree-alternate</b> command
TI-LFA	Indicates if TI-LFA is enabled or disabled under the <b>loopfree-alternate</b> command
Max SR FRR Labels	The maximum number of segment routing FRR labels
Export Limit	n/a
Export Limit Log Percent	n/a
Total Exp Routes	Indicates the total number of export routes
Segment Routing	Indicates whether segment routing is enabled
Database export	Indicates whether database export is enabled
ASN	n/a
Entropy Label	Indicates whether entropy label is enabled
Override ELC	Indicates whether entropy label capability is enabled for BGP tunnels

## virtual-link

### Syntax

**virtual-link database [detail]**

**virtual-link [detail]**

## Context

```
show>router>ospf
show>router>ospf3
```

## Description

This command displays information for OSPF virtual links.

## Parameters

### database

displays the virtual link database. This parameter applies only in the **ospf** context.

### detail

provides operational and statistical information for virtual links associated with this router

## Output

The following output is an example of OSPF virtual link information, and [Table 59: Virtual link field descriptions](#) describes the fields.

### Output example

```
A:ALU-A# show router ospf virtual-link
=====
Rtr Base OSPFv2 Instance 0 Virtual Links
=====
Nbr Rtr Id      Area Id      Local Interface  Metric State
-----
10.0.0.10     0.0.0.1     10.1.7.12       300    PToP
10.0.0.10     0.0.0.2     10.2.7.12       300    PToP
-----
No. of OSPF Virtual Links: 2
=====
A:ALU-A#
```

```
A:ALU-A# show router ospf virtual-link detail
=====
Rtr Base OSPFv2 Instance 0 Virtual Links (detail)
=====
Neighbor Router Id : 10.0.0.10
-----
Nbr Router Id : 10.0.0.10      Area Id      : 0.0.0.1
Local Interface: 10.1.7.12     Metric       : 300
State          : Point To Point Admin State   : Up
Hello Intrvl  : 10 sec        Rtr Dead Intrvl: 60 sec
Tot Rx Packets : 43022        Tot Tx Packets : 42964
Rx Hellos     : 24834        Tx Hellos     : 24853
Rx DBDs       : 3           Tx DBDs       : 2
Rx LSRs       : 0           Tx LSRs       : 0
Rx LSUs       : 15966       Tx LSUs       : 16352
Rx LS Acks    : 2219        Tx LS Acks    : 1757
Retransmits   : 0           Discards      : 0
Bad Networks  : 0           Bad Versions  : 0
Bad Areas     : 0           Bad Dest Adrs : 0
Bad Auth Types : 0         Auth Failures : 0
Bad Neighbors : 0           Bad Pkt Types : 0
Bad Lengths   : 0           Bad Hello Int. : 0
Bad Dead Int. : 0           Bad Options   : 0
```



```

Retrans Intrvl : 5 sec           Transit Delay : 1 sec
Last Event      : 11/07/2015 17:11:56 Authentication : None
-----
Neighbor Router Id : 10.0.0.10
-----
Nbr Router Id   : 10.0.0.10      Area Id         : 0.0.0.2
Local Interface : 10.2.7.12      Metric          : 300
State           : Point To Point Admin State     : Up
Hello Intrvl   : 10 sec         Rtr Dead Intrvl: 60 sec
Tot Rx Packets : 43073          Tot Tx Packets  : 43034
Rx Hellos      : 24851          Tx Hellos       : 24844
Rx DBDs        : 3              Tx DBDs         : 2
Rx LSRs        : 1              Tx LSRs         : 1
Rx LSUs        : 18071         Tx LSUs         : 17853
Rx LS Acks     : 147           Tx LS Acks      : 334
Retransmits    : 0              Discards        : 0
Bad Networks   : 0              Bad Versions    : 0
Bad Areas      : 0              Bad Dest Adrs  : 0
Bad Auth Types : 0              Auth Failures   : 0
Bad Neighbors  : 0              Bad Pkt Types   : 0
Bad Lengths    : 0              Bad Hello Int.  : 0
Bad Dead Int.  : 0              Bad Options     : 0
Retrans Intrvl : 5 sec         Transit Delay   : 1 sec
Last Event     : 11/07/2015 17:12:00 Authentication : None
=====
A:ALU-A#
    
```

Table 59: Virtual link field descriptions

Label	Description
Nbr Rtr ID	The router IDs of neighboring routers
Area Id	A 32-bit integer that identifies an area
Local Interface	The IP address of the local egress interface used to maintain the adjacency to reach this virtual neighbor
Metric	The metric value associated with the route. This value is used when importing this static route into other protocols. When the metric is configured as 0, then the metric configured in OSPF, default-metric, applies. This value is also used to determine which static route to install in the forwarding table.
State	The operational state of the virtual link to the neighboring router
Authentication	Specifies whether authentication is enabled for the interface or virtual link
Hello Intrvl	The length of time, in seconds, between the Hello packets that the router sends on the interface
Rtr Dead Intrvl	The total number of OSPF packets received where the dead interval given in the packet was not equal to that configured on this interface since the OSPF admin status was enabled

Label	Description
Tot Rx Packets	The total number of OSPF packets received on this interface since the OSPF admin status was enabled
Rx Hellos	The total number of OSPF Hello packets received on this interface since the OSPF admin status was enabled
Rx DBDs	The total number of OSPF database description packets received on this interface since the OSPF admin status was enabled
Rx LSRs	The total number of Link-State Requests (LSRs) received on this interface since the OSPF admin status was enabled
Rx LSUs	The total number of Link-State Updates (LSUs) received on this interface since the OSPF admin status was enabled
Rx LS Acks	The total number of Link-State Acknowledgments received on this interface since the OSPF admin status was enabled
Tot Tx Packets	The total number of OSPF packets transmitted on this interface since the OSPF admin status was enabled
Tx Hellos	The total number of OSPF Hello packets transmitted on this interface since the OSPF admin status was enabled
Tx DBDs	The total number of OSPF database description packets transmitted on this interface since the OSPF admin status was enabled
Tx LSRs	The total number of OSPF Link-State Requests (LSRs) transmitted on this interface since the OSPF admin status was enabled
Tx LSUs	The total number of OSPF Hello packets transmitted on this interface since the OSPF admin status was enabled
Tx LS Acks	The total number of OSPF Link-State Acknowledgments transmitted on this interface since the OSPF admin status was enabled
Retransmits	The total number of OSPF retransmits sent on this interface since the OSPF admin status was last enabled
Discards	The total number of OSPF packets discarded on this interface since the OSPF admin status was last enabled
Bad Networks	The total number of OSPF packets received with invalid network or mask since the OSPF admin status was last enabled
Bad Versions	The total number of OSPF packets received with bad OSPF version numbers since the OSPF admin status was last enabled

Label	Description
Bad Areas	The total number of OSPF packets received with an area mismatch since the OSPF admin status was last enabled
Bad Dest Addr	The total number of OSPF packets received with the incorrect IP destination address since the OSPF admin status was last enabled
Bad Auth Types	The total number of OSPF packets received with an invalid authorization type since the OSPF admin status was last enabled
Auth Failures	The total number of OSPF packets received with an invalid authorization key since the OSPF admin status was last enabled
Bad Neighbors	The total number of OSPF packets received where the neighbor information does not match the information this router has for the neighbor since the OSPF admin status was last enabled
Bad Pkt Types	The total number of OSPF packets received with an invalid OSPF packet type since the OSPF admin status was last enabled
Bad Lengths	The total number of OSPF packets received on this interface with a total length not equal to the length given in the packet itself since the OSPF admin status was last enabled
Bad Hello Int.	The total number of OSPF packets received where the hello interval given in the packet was not equal to that configured on this interface since the OSPF admin status was last enabled
Bad Dead Int.	The total number of OSPF packets received where the dead interval given in the packet was not equal to that configured on this interface since the OSPF admin status was last enabled
Bad Options	The total number of OSPF packets received with an option that does not match those configured for this interface or area since the OSPF admin status was last enabled
Retrans Intrvl	The length of time, in seconds, that OSPF waits before retransmitting an unacknowledged link-state advertisement (LSA) to an OSPF neighbor
Transit Delay	The time, in seconds, that it takes to transmit a link-state advertisement (LSA) on the interface or virtual link
Last Event	The date and time that an event was last associated with this OSPF interface

## virtual-neighbor

### Syntax

**virtual-neighbor** [*remote ip-address*] [**detail**]

**virtual-neighbor** [*remote ipv6-address*] [**detail**]

### Context

show>router>ospf

show>router>ospf3

### Description

This command displays virtual neighbor information.

The **detail** option produces a large amount of data. It is recommended that this option be used only when requesting information about a specific neighbor.

### Parameters

*ip-address*

specifies the IPv4 address of a remote virtual neighbor. This parameter applies in the **ospf** context and reduces the amount of output displayed.

*ipv6-address*

specifies the IPv6 address of a remote virtual neighbor. This parameter applies in the **ospf3** context and reduces the amount of output displayed.

**detail**

displays detailed information for the virtual neighbor

### Output

The following output is an example of OSPF virtual neighbor information, and [Table 60: Virtual neighbor field descriptions](#) describes the fields.

#### Output example

```
A:ALU-A# show router ospf virtual-neighbor
=====
Rtr Base OSPFv2 Instance 0 Virtual Neighbors
=====
Nbr IP Addr      Nbr Rtr Id      Nbr State Transit Area  RetxQ Len  Dead Time
-----
10.1.6.10        10.0.0.10       Full    0.0.0.1      0         58
10.2.9.10        10.0.0.10       Full    0.0.0.2      0         52
-----
No. of Neighbors: 2
=====
A:ALU-A#
```

```
A:ALU-A# show router ospf virtual-neighbor detail
=====
Rtr Base OSPFv2 Instance 0 Virtual Neighbors (detail)
```

```

=====
Virtual Neighbor Router Id : 10.0.0.10
-----
Neighbor IP Addr : 10.1.6.10      Neighbor Rtr Id : 10.0.0.10
Neighbor State   : Full           Transit Area    : 0.0.0.1
Retrans Q Length : 0              Options         : -E-
Events          : 4               Last Event Time : 11/07/2015 17:11:56
Up Time         : 2d 17:47:17     Time Before Dead : 57 sec
Bad Nbr States  : 1              LSA Inst fails  : 0
Bad Seq Nums    : 0              Bad MTUs        : 0
Bad Packets     : 0              LSA not in LSDB : 0
Option Mismatches : 0            Nbr Duplicates  : 0
-----
Virtual Neighbor Router Id : 10.0.0.10
-----
Neighbor IP Addr : 10.2.9.10      Neighbor Rtr Id : 10.0.0.10
Neighbor State   : Full           Transit Area    : 0.0.0.2
Retrans Q Length : 0              Options         : -E-
Events          : 4               Last Event Time : 11/07/2015 17:11:59
Up Time         : 2d 17:47:14     Time Before Dead : 59 sec
Bad Nbr States  : 1              LSA Inst fails  : 0
Bad Seq Nums    : 0              Bad MTUs        : 0
Bad Packets     : 0              LSA not in LSDB : 0
Option Mismatches : 0            Nbr Duplicates  : 0
=====
A:ALU-A#
    
```

Table 60: Virtual neighbor field descriptions

Label	Description
Nbr IP Addr	The IP address this neighbor is using in its IP source address. On links with no address, this will not be 0.0.0.0, but the address of another of the neighbor's interfaces.
Nbr Rtr ID	The router IDs of neighboring routers
Transit Area	The transit area ID that links the backbone area with the area that has no physical connection with the backbone
RetxQ Len/ Retrans Q Length	The current length of the retransmission queue
No. of Neighbors	The total number of OSPF neighbors adjacent on this interface, in a state of INIT or greater, since the OSPF admin status was enabled
Nbr State	The operational state of the virtual link to the neighboring router
Options	The total number of OSPF packets received with an option that does not match those configured for this virtual interface or transit area since the OSPF admin status was enabled
Events	The total number of events that have occurred since the OSPF admin status was enabled

Label	Description
Last Event Time	The date and time that an event was last associated with this OSPF interface
Up Time	The uninterrupted time, in hundredths of seconds, that the adjacency to this neighbor has been up
Dead Time/Time Before Dead	The amount of time, in seconds, until the dead router interval expires
Bad Nbr States	The total number of OSPF packets received where the neighbor information does not match the information this router has for the neighbor since the OSPF admin status was last enabled
LSA Inst fails	The total number of times an LSA could not be installed into the LSDB due to a resource allocation issue since the OSPF admin status was last enabled
Bad Seq Nums	The total number of times that a database description packet was received with a sequence number mismatch since the OSPF admin status was last enabled
Bad MTUs	The total number of times that the MTU in a received database description packet was larger than the MTU of the receiving interface since the OSPF admin status was enabled
Bad Packets	The total number of times that an LS update was received with an illegal LS type or an option mismatch since the OSPF admin status was enabled
LSA not in LSDB	The total number of times that an LS request was received for an LSA not installed in the LSDB of this router since the OSPF admin status was enabled
Option Mismatches	The total number of times that an LS update was received with an option mismatch since the OSPF admin status was enabled
Nbr Duplicates	The total number of times that a duplicate database description packet was received during the Exchange state since the OSPF admin status was enabled

### 4.14.2.3 Clear commands

ospf

#### Syntax

ospf

**Context**

```
clear>router
```

**Description**

This command clears and resets OSPF protocol entities.

```
ospf3
```

**Syntax**

```
ospf3
```

**Context**

```
clear>router
```

**Description**

This command clears and resets OSPFv3 protocol entities.

```
database
```

**Syntax**

```
database [purge]
```

**Context**

```
clear>router>ospf  
clear>router>ospf3
```

**Description**

This command clears all LSAs received from other nodes and refreshes all self-originated LSAs.

**Parameters**

**purge**

clears all self-originated LSAs and reoriginates all self-originated LSAs

```
export
```

**Syntax**

```
export
```

**Context**

```
clear>router>ospf
```

```
clear>router>ospf3
```

**Description**

This command re-evaluates all effective export route policies.

**neighbor****Syntax**

```
neighbor [ip-int-name | ip-address]
```

**Context**

```
clear>router>ospf
```

```
clear>router>ospf3
```

**Description**

This command marks the neighbor as dead and reinitiates the affected adjacencies.

**Parameters**

*ip-int-name*

clears all neighbors for the interface specified by this interface name

*ip-address*

clears all neighbors for the interface specified by this IP address

**statistics****Syntax**

```
statistics
```

**Context**

```
clear>router>ospf
```

```
clear>router>ospf3
```

**Description**

This command clears all neighbor, router, interface, SPF, and global statistics for OSPF.



#### 4.14.2.4 Monitor commands

```
ospf
```

##### Syntax

```
ospf
```

##### Context

```
monitor>router
```

##### Description

This command enables the context to configure monitor commands for the OSPF instance.

```
ospf3
```

##### Syntax

```
ospf3
```

##### Context

```
monitor>router
```

##### Description

This command enables the context to configure monitor commands for the OSPFv3 instance.

```
interface
```

##### Syntax

```
interface interface [interface...(up to 5 max)] [interval seconds] [repeat repeat] [absolute | rate]
```

##### Context

```
monitor>router>ospf
```

```
monitor>router>ospf3
```

##### Description

This command displays statistics for OSPF or OSPFv3 interfaces at the configured interval until the configured count is reached.

The first screen displays the current statistics related to the OSPF or OSPFv3 interface. The subsequent statistical information listed for each interval is displayed as a delta to the previous display.

When the keyword **rate** is specified, the rate-per-second for each statistic is displayed instead of the delta.

Monitor commands are similar to **show** commands but only statistical information displays. Monitor commands display the selected statistics according to the configured number of times at the interval specified.

## Parameters

### *interface*

the name of the IP interface or the IP address

**Values** *ip-int-name* | *ip-address* (OSPF only)

### *seconds*

configures the interval for each display, in seconds

**Values** 3 to 60

**Default** 10

### *repeat*

configures how many times the command is repeated

**Values** 1 to 999

**Default** 10

### **absolute**

displays raw statistics, without processing. No calculations are performed on the delta or rate statistics.

### **rate**

displays rate-per-second for each statistic instead of the delta

## Output

The following output is an example of OSPF interface information.

### Output example

```
A:ALA-12>monitor>router>ospf# interface to-104 interval 3 repeat 3 absolute
=====
Monitor statistics for OSPF Interface "to-104"
=====
At time t = 0 sec (Base Statistics)
-----
Tot Rx Packets : 8379          Tot Tx Packets : 8528
Rx Hellos      : 8225          Tx Hellos      : 8368
Rx DBDs        : 6            Tx DBDs        : 12
Rx LSRs        : 2            Tx LSRs        : 1
Rx LSUs        : 55           Tx LSUs        : 95
Rx LS Acks     : 91           Tx LS Acks     : 52
Retransmits    : 2            Discards       : 0
Bad Networks   : 0            Bad Virt Links : 0
Bad Areas      : 0            Bad Dest Adrs  : 0
Bad Auth Types : 0            Auth Failures  : 0
Bad Neighbors  : 0            Bad Pkt Types  : 0
Bad Lengths    : 0            Bad Hello Int. : 0
Bad Dead Int.  : 0            Bad Options    : 0
Bad Versions   : 0
```

```

-----
At time t = 3 sec (Mode: Absolute)
-----
Tot Rx Packets : 8379          Tot Tx Packets : 8528
Rx Hellos      : 8225          Tx Hellos      : 8368
Rx DBDs        : 6             Tx DBDs        : 12
Rx LSRs        : 2             Tx LSRs        : 1
Rx LSUs        : 55            Tx LSUs        : 95
Rx LS Acks     : 91            Tx LS Acks     : 52
Retransmits    : 2             Discards       : 0
Bad Networks   : 0             Bad Virt Links : 0
Bad Areas      : 0             Bad Dest Adrs  : 0
Bad Auth Types : 0             Auth Failures  : 0
Bad Neighbors  : 0             Bad Pkt Types  : 0
Bad Lengths    : 0             Bad Hello Int. : 0
Bad Dead Int.  : 0             Bad Options    : 0
Bad Versions   : 0
-----
At time t = 6 sec (Mode: Absolute)
-----
Tot Rx Packets : 8380          Tot Tx Packets : 8529
Rx Hellos      : 8226          Tx Hellos      : 8369
Rx DBDs        : 6             Tx DBDs        : 12
Rx LSRs        : 2             Tx LSRs        : 1
Rx LSUs        : 55            Tx LSUs        : 95
Rx LS Acks     : 91            Tx LS Acks     : 52
Retransmits    : 2             Discards       : 0
Bad Networks   : 0             Bad Virt Links : 0
Bad Areas      : 0             Bad Dest Adrs  : 0
Bad Auth Types : 0             Auth Failures  : 0
Bad Neighbors  : 0             Bad Pkt Types  : 0
Bad Lengths    : 0             Bad Hello Int. : 0
Bad Dead Int.  : 0             Bad Options    : 0
Bad Versions   : 0
-----
At time t = 9 sec (Mode: Absolute)
-----
Tot Rx Packets : 8380          Tot Tx Packets : 8529
Rx Hellos      : 8226          Tx Hellos      : 8369
Rx DBDs        : 6             Tx DBDs        : 12
Rx LSRs        : 2             Tx LSRs        : 1
Rx LSUs        : 55            Tx LSUs        : 95
Rx LS Acks     : 91            Tx LS Acks     : 52
Retransmits    : 2             Discards       : 0
Bad Networks   : 0             Bad Virt Links : 0
Bad Areas      : 0             Bad Dest Adrs  : 0
Bad Auth Types : 0             Auth Failures  : 0
Bad Neighbors  : 0             Bad Pkt Types  : 0
Bad Lengths    : 0             Bad Hello Int. : 0
Bad Dead Int.  : 0             Bad Options    : 0
Bad Versions   : 0
=====
A:ALA-12>monitor>router>ospf#

A:ALA-12>monitor>router>ospf# interface to-104 interval 3 repeat 3 rate
=====
Monitor statistics for OSPF Interface "to-104"
=====
At time t = 0 sec (Base Statistics)
-----
Tot Rx Packets : 8381          Tot Tx Packets : 8530
Rx Hellos      : 8227          Tx Hellos      : 8370
Rx DBDs        : 6             Tx DBDs        : 12

```

```

Rx LSRs      : 2          Tx LSRs      : 1
Rx LSUs      : 55         Tx LSUs      : 95
Rx LS Acks   : 91         Tx LS Acks   : 52
Retransmits  : 2          Discards     : 0
Bad Networks : 0          Bad Virt Links : 0
Bad Areas    : 0          Bad Dest Adrs : 0
Bad Auth Types : 0       Auth Failures : 0
Bad Neighbors : 0        Bad Pkt Types : 0
Bad Lengths  : 0         Bad Hello Int. : 0
Bad Dead Int. : 0        Bad Options   : 0
Bad Versions  : 0

```

```
-----
At time t = 3 sec (Mode: Rate)
-----
```

```

Tot Rx Packets : 0          Tot Tx Packets : 0
Rx Hellos      : 0          Tx Hellos      : 0
Rx DBDs        : 0          Tx DBDs        : 0
Rx LSRs        : 0          Tx LSRs        : 0
Rx LSUs        : 0          Tx LSUs        : 0
Rx LS Acks     : 0          Tx LS Acks     : 0
Retransmits    : 0          Discards       : 0
Bad Networks   : 0          Bad Virt Links : 0
Bad Areas      : 0          Bad Dest Adrs  : 0
Bad Auth Types : 0          Auth Failures  : 0
Bad Neighbors  : 0          Bad Pkt Types  : 0
Bad Lengths    : 0          Bad Hello Int. : 0
Bad Dead Int.  : 0          Bad Options    : 0
Bad Versions   : 0

```

```
-----
At time t = 6 sec (Mode: Rate)
-----
```

```

Tot Rx Packets : 0          Tot Tx Packets : 0
Rx Hellos      : 0          Tx Hellos      : 0
Rx DBDs        : 0          Tx DBDs        : 0
Rx LSRs        : 0          Tx LSRs        : 0
Rx LSUs        : 0          Tx LSUs        : 0
Rx LS Acks     : 0          Tx LS Acks     : 0
Retransmits    : 0          Discards       : 0
Bad Networks   : 0          Bad Virt Links : 0
Bad Areas      : 0          Bad Dest Adrs  : 0
Bad Auth Types : 0          Auth Failures  : 0
Bad Neighbors  : 0          Bad Pkt Types  : 0
Bad Lengths    : 0          Bad Hello Int. : 0
Bad Dead Int.  : 0          Bad Options    : 0
Bad Versions   : 0

```

```
-----
At time t = 9 sec (Mode: Rate)
-----
```

```

Tot Rx Packets : 0          Tot Tx Packets : 0
Rx Hellos      : 0          Tx Hellos      : 0
Rx DBDs        : 0          Tx DBDs        : 0
Rx LSRs        : 0          Tx LSRs        : 0
Rx LSUs        : 0          Tx LSUs        : 0
Rx LS Acks     : 0          Tx LS Acks     : 0
Retransmits    : 0          Discards       : 0
Bad Networks   : 0          Bad Virt Links : 0
Bad Areas      : 0          Bad Dest Adrs  : 0
Bad Auth Types : 0          Auth Failures  : 0
Bad Neighbors  : 0          Bad Pkt Types  : 0
Bad Lengths    : 0          Bad Hello Int. : 0
Bad Dead Int.  : 0          Bad Options    : 0
Bad Versions   : 0

```

```
=====
A:ALA-12>monitor>router>ospf#
```

## neighbor

### Syntax

**neighbor** *ip-address* [*ip-address...*(up to 5 max)] [**interval** *seconds*] [**repeat** *repeat*] [**absolute** | **rate**]

**neighbor** *router-id ip-int-name* [**interval** *seconds*] [**repeat** *repeat*] [**absolute** | **rate**] **area** *area-id*

### Context

monitor>router>ospf

monitor>router>ospf3

### Description

This command displays statistical OSPF or OSPFv3 neighbor information at the configured interval until the configured count is reached.

The first screen displays the current statistics related to the specified OSPF or OSPFv3 neighbors. The subsequent statistical information listed for each interval is displayed as a delta to the previous display.

When the keyword **rate** is specified, the rate-per-second for each statistic is displayed instead of the delta.

Monitor commands are similar to **show** commands but only statistical information displays. Monitor commands display the selected statistics according to the configured number of times at the interval specified.

### Parameters

*ip-address*

(OSPF): the IP address to display information for entries received from the specified OSPF neighbor. Up to five IP addresses can be specified.

**Values** a.b.c.d

*router-id*

(OSPFv3): the 32-bit router ID

**Values** a.b.c.d

*ip-int-name*

(OSPFv3): the IP interface name

*seconds*

configures the interval for each display, in seconds

**Values** 3 to 60

**Default** 10

*repeat*

configures the number of times the command is repeated

**Values** 1 to 999

**Default** 10

**absolute**

displays raw statistics, without processing. No calculations are performed on the delta or rate statistics.

**rate**

displays rate-per-second for each statistic instead of the delta

**area-id**

(OSPFv3): the OSPFv3 area ID, expressed in dotted-decimal notation or as a 32-bit decimal integer

**Values** *ip-address* | 0 to 4294967295

## Output

The following output is an example of OSPF neighbor information.

### Output example

```
A:ALA-12>monitor>router# ospf neighbor 10.0.0.104 interval 3 repeat 3 absolute
=====
Monitor statistics for OSPF Neighbor 10.0.0.104
=====
At time t = 0 sec (Base Statistics)
-----
Bad Nbr States      : 0                LSA Inst fails    : 0
Bad Seq Nums       : 0                Bad MTUs          : 0
Bad Packets        : 0                LSA not in LSDB  : 0
Option Mismatches : 0                Nbr Duplicates   : 0
-----
At time t = 3 sec (Mode: Absolute)
-----
Bad Nbr States      : 0                LSA Inst fails    : 0
Bad Seq Nums       : 0                Bad MTUs          : 0
Bad Packets        : 0                LSA not in LSDB  : 0
Option Mismatches : 0                Nbr Duplicates   : 0
-----
At time t = 6 sec (Mode: Absolute)
-----
Bad Nbr States      : 0                LSA Inst fails    : 0
Bad Seq Nums       : 0                Bad MTUs          : 0
Bad Packets        : 0                LSA not in LSDB  : 0
Option Mismatches : 0                Nbr Duplicates   : 0
-----
At time t = 9 sec (Mode: Absolute)
-----
Bad Nbr States      : 0                LSA Inst fails    : 0
Bad Seq Nums       : 0                Bad MTUs          : 0
Bad Packets        : 0                LSA not in LSDB  : 0
Option Mismatches : 0                Nbr Duplicates   : 0
=====
A:ALA-12>monitor>router#

A:ALA-12>monitor>router# ospf neighbor 10.0.0.104 interval 3 repeat 3 absolute
=====
Monitor statistics for OSPF Neighbor 10.0.0.104
=====
-----
```

```

At time t = 0 sec (Base Statistics)
-----
Bad Nbr States      : 0                LSA Inst fails    : 0
Bad Seq Nums       : 0                Bad MTUs          : 0
Bad Packets        : 0                LSA not in LSDB  : 0
Option Mismatches : 0                Nbr Duplicates   : 0
-----
At time t = 3 sec (Mode: Rate)
-----
Bad Nbr States      : 0                LSA Inst fails    : 0
Bad Seq Nums       : 0                Bad MTUs          : 0
Bad Packets        : 0                LSA not in LSDB  : 0
Option Mismatches : 0                Nbr Duplicates   : 0
-----
At time t = 6 sec (Mode: Rate)
-----
Bad Nbr States      : 0                LSA Inst fails    : 0
Bad Seq Nums       : 0                Bad MTUs          : 0
Bad Packets        : 0                LSA not in LSDB  : 0
Option Mismatches : 0                Nbr Duplicates   : 0
-----
At time t = 9 sec (Mode: Rate)
-----
Bad Nbr States      : 0                LSA Inst fails    : 0
Bad Seq Nums       : 0                Bad MTUs          : 0
Bad Packets        : 0                LSA not in LSDB  : 0
Option Mismatches : 0                Nbr Duplicates   : 0
=====
A:ALA-12>monitor>router#

```

## virtual-link

### Syntax

```
virtual-link nbr-rtr-id area area-id [interval seconds] [repeat repeat] [absolute | rate]
```

### Context

```
monitor>router>ospf
monitor>router>ospf3
```

### Description

This command displays statistical OSPF or OSPFv3 virtual link information at the configured interval until the configured count is reached.

The first screen displays the current statistics related to the specified neighbors. The subsequent statistical information listed for each interval is displayed as a delta to the previous display.

When the keyword **rate** is specified, the rate-per-second for each statistic is displayed instead of the delta.

Monitor commands are similar to **show** commands but only statistical information displays. Monitor commands display the selected statistics according to the configured number of times at the interval specified.

## Parameters

### *nbr-rtr-id*

the IP address to uniquely identify a neighboring router in the autonomous system

**Values** a.b.c.d

### *area-id*

the OSPF area ID, expressed in dotted-decimal notation or as a 32-bit decimal integer

**Values** *ip-address* | 0 to 4294967295

### *seconds*

configures the interval for each display, in seconds

**Values** 3 to 60

**Default** 10

### *repeat*

configures how many times the command is repeated

**Values** 1 to 999

**Default** 10

### **absolute**

displays raw statistics, without processing. No calculations are performed on the delta or rate statistics.

### **rate**

displays rate-per-second for each statistic instead of the delta

## virtual-neighbor

## Syntax

**virtual-neighbor** *nbr-rtr-id* **area** *area-id* [**interval** *seconds*] [**repeat** *repeat*] [**absolute** | **rate**]

**virtual-neighbor** *nbr-rtr-id* **transit-area** *transit-area* [**interval** *seconds*] [**repeat** *repeat*] [**absolute** | **rate**]

## Context

monitor>router>ospf

monitor>router>ospf3

## Description

This command displays statistical OSPF or OSPFv3 virtual neighbor information at the configured interval until the configured count is reached.

The first screen displays the current statistics related to the specified OSPF or OSPFv3 virtual neighbor router. The subsequent statistical information listed for each interval is displayed as a delta to the previous display.



When the keyword **rate** is specified, the rate-per-second for each statistic is displayed instead of the delta. Monitor commands are similar to **show** commands but only statistical information displays. Monitor commands display the selected statistics according to the configured number of times at the interval specified.

## Parameters

### *nbr-rtr-id*

the IP address to uniquely identify a neighboring router in the autonomous system

**Values** a.b.c.d

### *area-id*

(OSPF): the OSPF area ID, expressed in dotted-decimal notation or as a 32-bit decimal integer

**Values** *ip-address* | 0 to 4294967295

### *transit-area*

(OSPFv3): the OSPFv3 transit area ID, expressed in dotted-decimal notation or as a 32-bit decimal integer

**Values** *ip-address* | 0 to 4294967295

### *seconds*

configures the interval for each display, in seconds

**Values** 3 to 60

**Default** 10

### *repeat*

configures how many times the command is repeated

**Values** 1 to 999

**Default** 10

### **absolute**

displays raw statistics, without processing. No calculations are performed on the delta or rate statistics.

### **rate**

displays rate-per-second for each statistic instead of the delta

### 4.14.2.5 Debug commands

```
ospf
```

**Syntax**

```
ospf
```

**Context**

```
debug>router
```

**Description**

This command enables the context for OSPF debugging purposes.

```
ospf3
```

**Syntax**

```
ospf3
```

**Context**

```
debug>router
```

**Description**

This command enables the context for OSPFv3 debugging purposes.

```
area
```

**Syntax**

```
area [area-id]
```

```
no area
```

**Context**

```
debug>router>ospf
```

```
debug>router>ospf3
```

**Description**

This command enables or disables debugging for an OSPF area.

**Parameters***area-id*

the OSPF area ID expressed in dotted-decimal notation or as a 32-bit decimal integer

**area-range****Syntax****area-range** [*ip-address*]**no area-range****Context**

debug&gt;router&gt;ospf

debug&gt;router&gt;ospf3

**Description**

This command enables or disables debugging for an OSPF area range.

**Parameters***ip-address*

the IP address for the range used by the ABR to advertise into another area

**cspf****Syntax****cspf** [*ip-address*]**no cspf****Context**

debug&gt;router&gt;ospf

**Description**

This command enables or disables debugging for an OSPF constraint-based shortest path first (CSPF).

**Parameters***ip-address*

the IP address for the range used for CSPF

## interface

### Syntax

**interface** [*ip-int-name* | *ip-address*]

**no interface**

### Context

debug>router>ospf

debug>router>ospf3

### Description

This command enables or disables debugging for an OSPF interface.

### Parameters

*ip-int-name*

the IP interface name. An interface name cannot be in the form of an IP address. Interface names can be any string up to 32 characters long composed of printable, 7-bit ASCII characters. If the string contains special characters (such as #, \$, or spaces), the entire string must be enclosed within double quotes.

*ip-address*

the interface's IP address

## leak

### Syntax

**leak** [*ip-address*]

**no leak**

### Context

debug>router>ospf

debug>router>ospf3

### Description

This command enables or disables debugging for OSPF leaks.

### Parameters

*ip-address*

the IP address to debug OSPF leaks

## lsdb

### Syntax

**lsdb** [**type**] [*ls-id*] [*adv-rtr-id*] [**area** *area-id*]

**no lsdb**

### Context

debug>router>ospf

debug>router>ospf3

### Description

This command enables or disables debugging for an OSPF link-state database.

### Parameters

#### **type**

the OSPF link-state database type

**Values** router, network, summary, asbr, extern, nssa

#### *ls-id*

an LSA type-specific field containing either a router ID or an IP address. It identifies the piece of the routing domain being described by the advertisement.

#### *adv-rtr-id*

the router identifier of the router advertising the LSA

#### *area-id*

the OSPF area ID expressed in dotted-decimal notation or as a 32-bit decimal integer

## misc

### Syntax

**[no] misc**

### Context

debug>router>ospf

debug>router>ospf3

### Description

This command enables or disables debugging for miscellaneous OSPF events.

## neighbor

### Syntax

**neighbor** [*ip-int-name* | *router-id*]

**no neighbor**

### Context

debug>router>ospf

debug>router>ospf3

### Description

This command enables or disables debugging for an OSPF neighbor.

### Parameters

*ip-int-name*

the neighbor interface name

*router-id*

neighbor information for the neighbor identified by the specified router ID

## nssa-range

### Syntax

**nssa-range** [*ip-address*]

**no nssa-range**

### Context

debug>router>ospf

debug>router>ospf3

### Description

This command enables or disables debugging for an NSSA range.

### Parameters

*ip-address*

the IP address range to debug

## packet

### Syntax

**packet** [*packet-type*] [*ip-address*]

**no packet**

### Context

debug>router>ospf

debug>router>ospf3

### Description

This command enables or disables debugging for OSPF packets.

### Parameters

*packet-type*

the OSPF packet type to debug

**Values** hello, dbdescr, lsrequest, lsupdate, lsack

*ip-address*

the IP address to debug

## rsvp-shortcut

### Syntax

**rsvp-shortcut** [*ip-address*]

**no rsvp-shortcut**

### Context

debug>router>ospf

### Description

This command enables or disables debugging for RSVP-TE LSPs that are used as shortcuts.

### Parameters

*ip-address*

the IP address to debug

## rtm

### Syntax

**rtm** [*ip-address*]

**no rtm**

### Context

debug>router>ospf

debug>router>ospf3

### Description

This command enables or disables debugging for the OSPF routing table manager.

### Parameters

*ip-address*

the IP address to debug

## sham-neighbor

### Syntax

**sham-neighbor** [*ip-address*]

**no sham-neighbor**

### Context

debug>router>ospf

### Description

This command enables or disables debugging for an OSPF sham-link neighbor.

### Parameters

*ip-address*

the IP address to debug

## spf

### Syntax

**spf** [*type*] [*dest-addr*]

**no spf**



## Context

```
debug>router>ospf
debug>router>ospf3
```

## Description

This command enables or disables debugging for OSPF SPF. Information regarding overall SPF start and stop times are shown. To see detailed information regarding the SPF calculation of a given route, the route must be specified as an optional argument.

## Parameters

*type*

the area to debug

**Values** intra-area, inter-area, external

*dest-addr*

the destination IP address to debug

## virtual-neighbor

## Syntax

```
virtual-neighbor [ip-address]
no virtual-neighbor
```

## Context

```
debug>router>ospf
debug>router>ospf3
```

## Description

This command enables or disables debugging for an OSPF virtual neighbor.

## Parameters

*ip-address*

the IP address of the virtual neighbor

## 5 IS-IS

This chapter provides information about configuring the Intermediate System-to-Intermediate System (IS-IS) protocol.

Topics in this chapter include:

- [Overview of IS-IS](#)
- [Bidirectional forwarding detection \(BFD\) for IS-IS](#)
- [LDP and IP fast reroute \(FRR\) for IS-IS prefixes](#)
- [IS-IS configuration process overview](#)
- [Configuration notes](#)
- [Configuring IS-IS with CLI](#)
- [IS-IS command reference](#)

### 5.1 Overview of IS-IS

IS-IS is an interior gateway protocol (IGP), similar to OSPF, that is used within large autonomous systems (ASs). IS-IS is a link-state protocol. Each IS-IS router maintains an identical database (called the link-state database, topological database, or routing information database (RIB)) of the AS, including information about the local state of each router (for example, its usable interfaces and reachable neighbors).

IS-IS-TE (IS-IS with traffic engineering extensions) is used to advertise reachability information and traffic engineering information such as available bandwidth.

The 7705 SAR also supports multiple instances of IS-IS (MI-IS-IS).

Entities in IS-IS include networks, intermediate systems, and end systems. In IS-IS, a network is an autonomous system (AS), or routing domain, with intermediate systems and end systems. A router, such as the 7705 SAR, is an intermediate system. Intermediate systems send, receive, and forward protocol data units (PDUs). End systems are network devices (or hosts) that send and receive PDUs but do not forward them.

Intermediate system and end system protocols allow routers and nodes to identify each other. IS-IS sends out link-state updates (called link-state PDUs, or LSPs) periodically throughout the network so that each router can maintain current network topology information.

IS-IS uses a cost metric that represents the status of a link, and (optionally) the bandwidth of the interface, in an algorithm that determines the best route to a destination. This algorithm is called the shortest path first (SPF), or Dijkstra, algorithm. Routing decisions are made using the link-state information. IS-IS evaluates topology changes and, if necessary, performs SPF recalculations.

When the best route to a particular destination is determined, the route information is sent to the routing table manager (RTM). The RTM may contain more than one best route to a destination from multiple protocols. Because metrics from different protocols are not comparable, the RTM uses the concept of preference to select the best route. The route with the lowest preference value is selected.

The best routes from the RTM are then added to the forwarding table (also known as the forwarding information base (FIB)). All forwarding decisions are based on the information in the forwarding database.

The forwarding (or dropping) of packets is controlled by filters applied to the interface and route policies applied to the IS-IS protocol. See the 7705 SAR Router Configuration Guide for information about filters and route policies.

The following major IS-IS features are supported:

- [IS-IS areas \(two-level hierarchy\)](#)
- [ISO network addressing](#)
- [Neighbors and adjacencies](#)
- [Metrics](#)
- [Authentication](#)
- [Route redistribution and summarization](#)
- [IS-IS-TE extensions](#)
- [Unnumbered interfaces](#)
- [Multitopology IS-IS](#)
- [Segment routing in shortest path forwarding](#)
- [Multi-instance IS-IS \(MI-IS-IS\)](#)
- [IPv6 support](#)

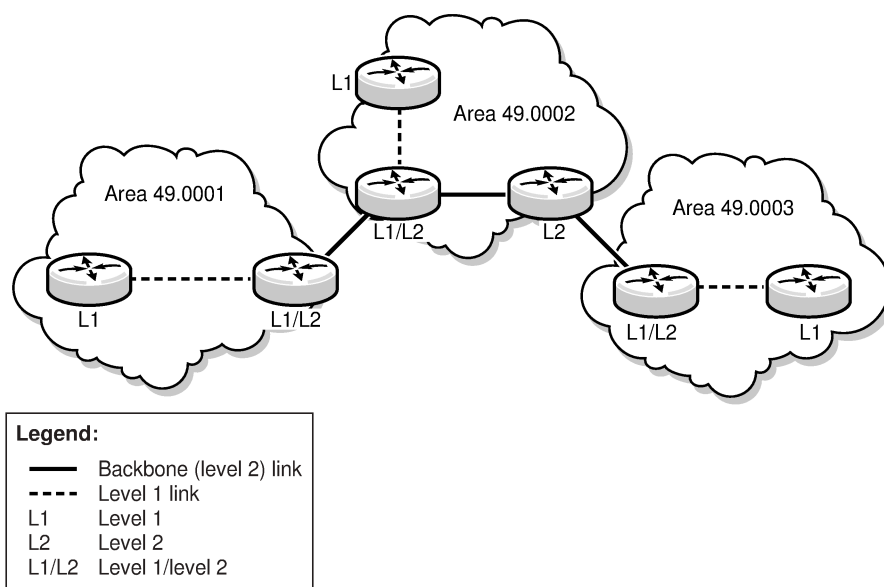
### 5.1.1 IS-IS areas (two-level hierarchy)

IS-IS can subdivide an autonomous system into areas to simplify the calculation of routes and minimize the size of IP routing tables. When an AS is divided into areas, each IS-IS router in an area must maintain an identical link-state database of the area topology, but routes from other areas can be summarized. Sometimes one "default" route can be used to represent many different routes. The topology is hidden from routing devices in other areas, which minimizes the size of the link-state database and reduces IS-IS link-state PDUs (LSPs). See [Route redistribution and summarization](#).

IS-IS uses a two-level hierarchy when dividing an AS into smaller areas. A system logically belongs to one area. Level 1 routing is performed within an area. Level 2 routing is performed between areas. The 7705 SAR can be configured as a level 1 router, level 2 router, or level 1/2 router. By default, the 7705 SAR is a level 1/2 router, which enables the router to operate as a level 1 and/or a level 2 router with the associated databases. The router runs separate shortest path first (SPF) calculations for the level 1 area routing and for the level 2 multi-area routing to create the IS-IS routing table for the IS-IS instance.

The following figure shows an example of an IS-IS topology.

Figure 20: IS-IS topology



20355

Level 1 routers know the topology in their area, including all routers and end systems, but do not know the identity of routers or destinations outside of their area. To reach a destination outside of the level 1 area, level 1 routers forward the packets to a level 1/2 router in their area as the next hop.

In order for level 1 routers to forward traffic to a level 1/2 router, the level 1/2 router sets the Attached (ATT) bit in its level 1 LSP, which indicates that it is attached to another area, and floods it to all the level 1 neighbors. The level 1 router installs the default route to the level 1/2 router in its routing table. If there is more than one level 1/2 router connected to the level 1 area, the level 1 router only installs the default route of the closest level 1/2 router. The level 1 router then forwards all traffic with a destination outside of its area to this level 1/2 router.

In some cases, users may want to control whether a level 1 router forwards traffic to a specific level 1/2 router; for example, it may be desirable to route around a particular level 1/2 router for traffic engineering reasons. This can be done by configuring a level 1 router to ignore the ATT bit on received level 1 LSPs (using the `config>router>isis>ignore-attached-bit` command) or configuring a level 1/2 router to suppress the ATT bit on originating level 1 LSPs (using the `config>router>isis>suppress-attached-bit` command). In the first case, when the level 1 router ignores the ATT bit, it will not install the default route to the level 1/2 router. In the second case, when the level 1/2 router suppresses the ATT bit, all level 1 routers in the area are prevented from installing the default route.

Sometimes the shortest path to an outside destination is not through the closest level 1/2 router, or the only level 1/2 router to forward packets out of an area is not operational. To reduce suboptimal routing, route leaking provides a mechanism to leak (or redistribute) level 2 information into level 1 areas to provide routing information about inter-area routes. By distributing more detailed information into the level 1 area, a level 1 router is able to make a better decision as to which level 1/2 router should forward the packet.

The 7705 SAR implementation of IS-IS route leaking is in compliance with RFC 2966, *Domain-wide Prefix Distribution with Two-Level IS-IS*.

Level 2 routers know the level 2 topology and know which addresses are reachable by each level 2 router. Level 2 routers do not need to know the topology within any level 1 area, except if the level 2 router is

also a level 1 router within a single area. By default, only level 2 routers can exchange PDUs or routing information directly with external routers located outside the routing domain.

The following table describes the router types (or intermediate systems) within IS-IS.

*Table 61: IS-IS intermediate systems*

Intermediate system	Description
Level 1	<p>Maintains a link-state database of other routers that reside in the same area (local area)</p> <p>Exchanges topology information for the local area</p> <p>Routing is performed within the area, based on the area ID portion of the ISO address (see <a href="#">ISO network addressing</a>)</p> <p>If the destination address is in the area (area ID is equal), routers forward the packets to the level 1 router that is advertising the destination address, based on the system ID</p> <p>If the destination address is not in the area (area ID is not equal), routers forward the packet to the nearest level 1/2 router in the local area</p>
Level 2	<p>Resides within an area but connects to other level 2 routers in multiple areas in a backbone mesh</p> <p>Maintains a link-state database of other level 2 routers and of the level 1/2 routers in each local area</p> <p>Exchanges topology information between areas</p> <p>Routing is performed between areas based on the area address</p>
Level 1/2	<p>Acts as an area border router with links to the level 2 backbone as well as to the level 1 routers within its area</p> <p>Maintains two link-state databases – a level 1 link-state database of the routers in the local area and a level 2 link-state database of the backbone and any level 1/2 routers</p> <p>Exchanges topology information within the local area and between areas</p> <p>Routing is performed within and between areas</p> <p>If the destination address is in the area (area ID is equal), routers use the level 1 database to forward the packets to the level 1 router that is advertising the destination address, based on the system ID</p> <p>If the destination address is not in the area (area ID is not equal), routers use the level 2 database to forward the packet based on the area ID</p>

## 5.1.2 ISO network addressing

IS-IS uses ISO network addresses. There are two types of network addresses:

- network service access point (NSAP)

NSAP addresses identify a point of connection to the network, such as a router interface. Each NSAP represents a service that is available at that node. An end system can have multiple NSAP addresses; the addresses differ only by the last byte (called the *n*-selector). In addition to having multiple services, a single node can belong to multiple areas.

- network entity title (NET)

NET addresses identify network layer entities or processes instead of services. Structurally, an NET is identical to an NSAP address but has an *n*-selector of 00. Most end systems have one NET. Intermediate systems (routers) can have up to three NETs, differentiated by the area ID.

NSAP addresses are divided into three parts. Only the area ID portion is configurable:

- area ID – a variable-length field between 1 and 13 bytes that identifies the area to which the router belongs. This field includes the Authority and Format Identifier (AFI) as the first (most significant byte) and the area identifier.
- system ID – A 6-byte system identifier. This value is not configurable. The system ID is derived from the system or router ID and uniquely identifies the router.
- selector ID – A 1-byte selector identifier that is always 00 for an NET. This value is not configurable.

The area ID portion of the NET can be manually configured with 1 to 13 bytes. If fewer than 13 bytes are entered, the rest of the field is padded with zeros.

### 5.1.3 Neighbors and adjacencies

IS-IS routers discover their neighbors by exchanging Hello PDUs. Neighbors are routers that have an interface to a common network/area. In a broadcast-supported topology, one router sends Hello packets to a multicast address and receives Hello packets in return. In non-broadcast topologies, unicast Hello packets are used.

Because all routing devices on a common network must agree on certain parameters, these parameters are included in Hello packets. Differences in these parameters can prevent neighbor relationships from forming.

A level 1 router will not become a neighbor with a node that does not have a common area address. However, if a level 1 router has area addresses A, B, and C, and a neighbor has area addresses B and D, the level 1 router will accept the other node as a neighbor because address B is common to both routers.

When Hello packets have been successfully exchanged, the neighbors are considered to be adjacent.

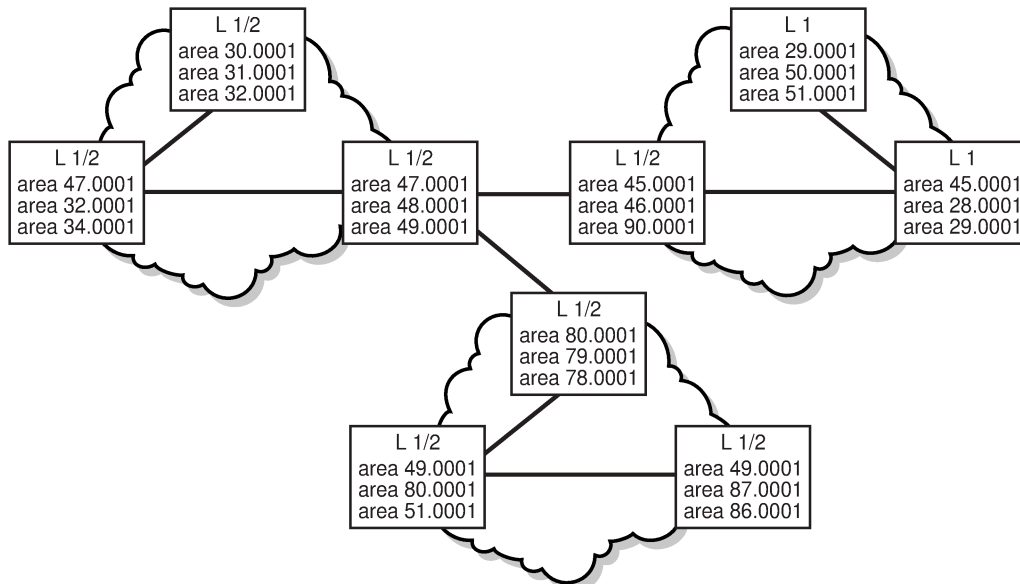
Within an area, level 1 routers exchange link-state PDUs (LSPs) that identify the IP addresses reachable by each router. Each router has one LSP that contains information about that router; included in each LSP can be zero or more IP addresses, subnet masks, and metric combinations. Each level 1 router is manually configured with the IP address, subnet mask, and metric combinations that are reachable on each interface.

Level 2 routers exchange LSPs that include a complete list of IP addresses, subnet masks, and metrics specifying all the IP addresses that are reachable in their area. Level 2 routers can also report external reachability information, corresponding to addresses reachable by routers in other routing domains or autonomous systems.

Routers with common area addresses form level 1 adjacencies. Routers with no common NET addresses form level 2 adjacencies, if they are capable. See [Figure 21: Using area addresses to form adjacencies](#).

Level 2 adjacencies are formed with other level 2 nodes whose area addresses do not overlap. If the area addresses do not overlap, the link is considered by both routers to be level 2 and only level 2 LSPs flow on the link.

Figure 21: Using area addresses to form adjacencies



20108

### 5.1.3.1 Designated routers

In multi-access broadcast networks, such as Ethernet networks, with at least two attached routers, a designated router can be elected. The IS-IS protocol refers to the designated router as the designated intermediate system (DIS).

The concept of a designated router was developed in order to avoid the formation of adjacencies between all attached routers. Without a designated router, the area would be flooded with link-state PDUs (LSPs) —a router would send LSPs to all its adjacent neighbors, and each in turn would send LSPs to all their neighbors, and so on. This would create multiple copies of the same LSP on the same link.

The designated router reduces the number of adjacencies required because each router forms an adjacency only with the designated router. Only the designated router sends LSPs in multicast format to the rest of the network, reducing the amount of routing protocol traffic.

In IS-IS, a broadcast subnetwork with multiple connected routers is considered to be a pseudonode. The pseudonode has links to each of the routers and each of the routers has a single link to the pseudonode (instead of links to each of the other routers). LSPs are generated on behalf of the pseudonode by the DIS.

The DIS has two tasks:

- create and update the pseudonode LSP
- flood the LSP over the LAN

The DIS is automatically elected based on the interface priority of the router and/or if it has the highest MAC address of all routers in the LAN. If all interface priorities are the same, the router with the highest subnetwork point of attachment (SNPA) is selected. The SNPA is the MAC address on a LAN.

Every IS-IS router interface is assigned both a level 1 priority and a level 2 priority. If a new router starts up in the LAN and has a higher interface priority, the new router preempts the original DIS and becomes the new DIS. The new DIS purges the old pseudonode LSP and floods a new set of LSPs.

Because different priorities can be set according to level 1 or level 2 routing, there can be two different routers in an Ethernet LAN that are DIS-designated. One DIS supports all level 1 routers, and the other DIS supports all level 2 routers on that segment.

The DIS generates the pseudonode LSP. The DIS reports all LAN neighbors (including itself) in the pseudonode link-state PDU (LSP). All LAN routers communicate with the pseudonode via their LSPs. The pseudonode reduces the number of adjacencies by having all physical devices exchange information only with the pseudonode. Each router listens for updates to the pseudonode and updates its individual topology according to those updates.



**Note:**

- In point-to-point networks, where a single pair of routers is connected, no designated router is elected. An adjacency must be formed with the neighbor router.
- To significantly improve adjacency forming and network convergence, a network should be configured as point-to-point if only two routers are connected, even if the network is a broadcast media such as Ethernet.

### 5.1.3.2 IS-IS packet types

The following table describes the packet types used by IS-IS to exchange protocol information.

*Table 62: IS-IS packet types*

Packet type	Description
Hello PDUs	Routers with IS-IS enabled send Hello PDUs to IS-IS-enabled interfaces to discover neighbors and establish adjacencies.
Link-state PDUs (LSPs)	LSPs contain information about the state of adjacencies to neighboring IS-IS systems and are used to build the link-state database. LSPs are flooded periodically throughout an area. Level 1 and level 2 LSPs are supported.
Complete sequence number PDUs (CSNPs)	In order for all routers to maintain the same information (synchronize), CSNPs inform other routers that some LSPs might be outdated or missing from their database. CSNPs contain a complete list of all LSPs in the current IS-IS database. Level 1 and level 2 CSNPs are supported.
Partial sequence number PDUs (PSNPs)	PSNPs are used to request missing LSPs and acknowledge that an LSP was received. Level 1 and level 2 PSNPs are supported.



When a change takes place, IS-IS sends only the changed information, not the whole topology information or whole link-state database. From the topological database, each router constructs a tree of shortest paths with itself as root (that is, runs the Dijkstra algorithm). IS-IS distributes routing information between routers belonging to a single AS.

To summarize:

- Hello PDUs are sent over the IS-IS-enabled interfaces to discover neighbors and establish adjacencies.
- IS-IS neighbor relationships are formed if the Hello PDUs contain information that meets the criteria for forming an adjacency.
- Routers can build a link-state PDU based upon their local interfaces that are configured for IS-IS and prefixes learned from other adjacent routers.
- Routers flood LSPs to the adjacent neighbors except the neighbor from which they received the same LSP. The link-state database is constructed from these LSPs.
- A shortest path tree (SPT) is calculated by each router, and from this SPT the routing table is built.

### 5.1.4 Metrics

IS-IS uses a cost metric that represents the status of a link in an algorithm to determine the best route to a destination. This algorithm is called the shortest path first (SPF), or Dijkstra, algorithm. Routing decisions are made using the link-state information. IS-IS evaluates topology changes and, if necessary, performs SPF recalculations.

To calculate the lowest cost to reach a destination, each configured level on each interface must have a cost. The costs for each level on an interface may be different.

In IS-IS, if the metric is not configured, the default cost 10 is used, regardless of the actual capacity of the link. By default, IS-IS does not use reference bandwidth in the calculation, unlike OSPF.

### 5.1.5 Authentication

Protocol authentication protects against malicious attacks on the communications between routing protocol neighbors. These attacks could either disrupt communications or inject incorrect routing information into the system's routing table. The use of authentication keys can help to protect routing protocols from these types of attacks.

All IS-IS protocol exchanges can be authenticated. This guarantees that only trusted routers can participate in autonomous system routing.

Authentication must be explicitly configured and can be done using two separate mechanisms:

- configuration of an explicit authentication key and algorithm using the **authentication-key** and **authentication-type** commands
- configuration of an authentication keychain using the **auth-keychain** command

Either the **authentication-key** command or the **auth-keychain** command can be used by IS-IS, but both cannot be supported at the same time. If both commands are configured, the **auth-keychain** configuration will be applied and the **authentication-key** command will be ignored.

By default, authentication is not enabled on an interface.

### 5.1.5.1 Authentication key

For explicit authentication keys, IS-IS supports plaintext (simple password) and Message Digest 5 (MD5) authentication.

When authentication is enabled on a link, a text string password must be configured. Neighbor IS-IS routers must supply the password in all IS-IS packets they send to an interface.

Plaintext authentication includes the password in each IS-IS packet sent on a link.

MD5 authentication is more secure than plaintext authentication. MD5 authentication uses the password as an encryption key. Routers in the same routing domain must be configured with the same key. When the MD5 hashing algorithm is used for authentication, MD5 is used to verify data integrity by creating a 128-bit message digest from the data input that is included in each packet. The packet is transmitted to the router neighbor and can only be decrypted if the neighbor has the correct password.

The following authentication commands can be configured in the IS-IS global and IS-IS level contexts:

- **authentication-key** – configures the authentication password used to verify IS-IS protocol packets
- **authentication-type** – enables authentication and specifies the type of authentication to be used, either password or message digest

The following Hello PDU authentication commands can be configured in the IS-IS interface and IS-IS interface level contexts:

- **hello-authentication-key** – configures the authentication password for Hello PDUs
- **hello-authentication-type** – enables Hello authentication and specifies the type of authentication to be used, either password or message digest

### 5.1.5.2 Authentication keychains

The keychain mechanism allows for the creation of keys used to authenticate IS-IS communications. Each keychain entry defines the authentication attributes to be used in authenticating IS-IS messages from remote peers or neighbors; the entry must include at least one key entry to be valid. The keychain mechanism also allows authentication keys to be changed without affecting the state of the IS-IS adjacencies and supports stronger authentication algorithms than plaintext and MD5.

Keychains are configured in the **config>system>security>keychain** context. For more information about configuring keychains, see the 7705 SAR System Management Guide, "TCP Enhanced Authentication and Keychain Authentication".

The authentication keychain is then associated with IS-IS in the global or level contexts with the **auth-keychain** command. The Hello authentication keychain is associated with IS-IS in the global, interface, or interface level contexts with the **hello-auth-keychain** command.

For a key entry to be valid, it must include a valid key, the current system clock value must be within the begin and end time of the key entry, and the algorithm specified must be supported by IS-IS.

IS-IS supports the following authentication algorithms:

- clear text password
- HMAC-MD5
- HMAC-SHA-1
- HMAC-SHA-256

Keychain errors are handled as follows.

- If a keychain exists but there are no active key entries with an authentication type that matches the type supported by IS-IS, inbound IS-IS packets will not be authenticated and will be discarded and no outbound IS-IS packets will be sent.
- If a keychain exists but the last key entry has expired, a log entry will be raised indicating that all keychain entries have expired.

IS-IS protocol requires that the protocol not revert to an unauthenticated state and requires that the old key not be used; therefore, when the last key has expired, all traffic will be discarded.

## 5.1.6 Route redistribution and summarization

### 5.1.6.1 Route redistribution

Route redistribution is the taking of routes from one protocol and sending them to another protocol. The 7705 SAR supports the redistribution of static routes into OSPF and IS-IS and the redistribution of routes between IS-IS levels. The routes can be redistributed as level 1, level 2, or level 1/2 routes, depending on the level capability of the IS-IS router.

Multi-instance IS-IS (MI-IS-IS) supports route redistribution:

- to and from any other routing protocol
- to and from any other IS-IS instance

Route redistribution involves the use of routing policies. For information about routing policies, see the 7705 SAR Router Configuration Guide, "Route Policies". To configure route redistribution, see [Redistributing external IS-IS routes](#).

### 5.1.6.2 Route summarization

IS-IS IPv4 route summarization allows users to create aggregate IPv4 addresses that include multiple groups of IPv4 addresses for a given IS-IS level. Routes redistributed from other routing protocols can also be summarized.

IS-IS route summarization helps to reduce the size of the link-state database and the routing table. It also helps to reduce the chance of route flapping, which may occur when a router alternately advertises a destination network via one route then another route in quick sequence (or advertises a route as unavailable then available again).

#### 5.1.6.2.1 Partial SPF calculation

IS-IS supports partial SPF calculation, also referred to as partial route calculation. When an event does not change the topology of the network, IS-IS does not perform full SPF but instead performs an IP reachability calculation for impacted routes. Partial SPF is performed at the receipt of IS-IS LSPs with changes to IP reachability TLVs and, in general, for any IS-IS LSP TLV and sub-TLV change that does not impact the network topology.

### 5.1.7 IS-IS-TE extensions

IS-IS traffic engineering (TE) extensions enable the 7705 SAR to include traffic engineering information in the algorithm in order to calculate the best route to a destination. IS-IS-TE extensions are used by MPLS traffic engineering; that is, RSVP-TE. The traffic information includes:

- maximum reservable bandwidth
- unreserved bandwidth
- available bandwidth
- link administration groups (or link colors)
- SRLGs
- TE metrics

### 5.1.8 Unnumbered interfaces

IS-IS supports unnumbered point-to-point interfaces with both Ethernet and PPP encapsulations.

Unnumbered interfaces borrow the address from other interfaces such as system, loopback, or another numbered interface, and use it as the source IP address for packets originated from the interface.

This feature supports both dynamic and static ARP for unnumbered interfaces to allow interworking with unnumbered interfaces that may not support dynamic ARP.

An unnumbered interface has IPv4 capability and is used only in cases where IPv4 is active (IPv4-only and mixed IPv4/IPv6 environments). When configuring an unnumbered interface, the interface specified for the unnumbered interface (system or other) must have an IPv4 address. As well, the interface type for the unnumbered interface will automatically be point-to-point.

The unnumbered option can be used in IES and VPRN access interfaces, as well as in a network interface with MPLS support.

### 5.1.9 Multitopology IS-IS

Multitopology IS-IS (MT IS-IS) allows the creation of different topologies in IS-IS that contribute routes to specific route tables for IPv4 unicast, IPv6 unicast, IPv4 multicast, and IPv6 multicast. This capability allows for noncongruent topologies among these routing tables. As a result, networks are able to control which links or nodes are used for forwarding different types of traffic. For example, in a network enabled for MT IS-IS, all links can carry IPv4 traffic while a subset of links also carry IPv6 traffic.

The 7705 SAR supports the following multitopologies:

- IPv4 unicast routing topology, with MT ID 0
- IPv6 unicast routing topology, with MT ID 2
- IPv4 multicast routing topology, with MT ID 3
- IPv6 multicast routing topology, with MT ID 4

MT IS-IS is supported in every instance of IS-IS.

Segment routing is supported in MT 0. See [IS-IS control protocol changes](#) for information.

The 7705 SAR also supports IS-IS IPv6 TLVs for IPv6 routing. This support is considered native IPv6 routing in IS-IS. For information about native IPv6 routing, see [IPv6 support](#).

### 5.1.10 Segment routing in shortest path forwarding

Segment routing adds to IS-IS and OSPF routing protocols the ability to perform shortest path routing and source routing using the concept of abstract segment. A segment can represent a local prefix of a node, a specific adjacency of the node (interface or next hop), a service context, or a specific explicit path over the network. For each segment, the IGP advertises an identifier referred to as a segment ID (SID).



**Note:** Segment routing is supported in IS-IS for IPv4 and IPv6 and only in OSPFv2 for IPv4.

When segment routing is used together with the MPLS data plane, the SID is a standard MPLS label. A router forwarding a packet using segment routing will push one or more MPLS labels.

Segment routing using MPLS labels can be used in both shortest path routing applications and traffic engineering applications. On the 7705 SAR, segment routing implements the shortest path forwarding application.

When a received IPv4 or IPv6 prefix SID is resolved, the segment routing module programs the ILM with a swap operation and programs the LTN with a push operation both pointing to the primary/LFA NHLFE. An IPv4 or IPv6 SR tunnel to the prefix destination is also added to the TTM and is available for use by shortcut applications and Layer 2 or Layer 3 services.

Segment routing introduces the remote LFA feature, which expands the coverage of LFA by computing and automatically programming SR tunnels that are used as backup next hops. The SR shortcut tunnels terminate on a remote alternate node, which provides loop-free forwarding for packets of the resolved prefixes. When the **loopfree-alternates** option is enabled in an IS-IS instance or in OSPF, SR tunnels are protected with an LFA backup next hop. If the prefix of an SR tunnel is not protected by the base LFA, remote LFA automatically computes a backup next hop using an SR tunnel if the **remote-lfa** option is also enabled in the IGP instance.

Segment routing can also be used with Layer 3 spoke SDP interfaces to support multicast (PIM only). See [Multicast over Layer 3 spoke SDP interfaces](#) for more information.

#### 5.1.10.1 Configuring segment routing in shortest path

Segment routing is enabled in an IGP routing instance using the following sequence of commands.

First, the user configures the global label block, referred to as the Segment Routing Global Block (SRGB), which is reserved for assigning labels to segment routing prefix SIDs originated by this router. This range is within the system dynamic label range and by default is not instantiated:

```
config>router>mpls-labels>sr-labels start start-value end end-value
```

Next, the user enables the context to configure segment routing parameters within an IGP instance:

```
config>router>isis>segment-routing
```

```
config>router>ospf>segment-routing
```

The key parameter is the configuration of the prefix SID index range and the offset label value that this IGP instance uses. Because each prefix SID represents a network global IP address, the SID index for a prefix must be unique network-wide. All routers in the network are expected to configure and advertise the same prefix SID index range for an IGP instance. However, the label value used by each router to represent this

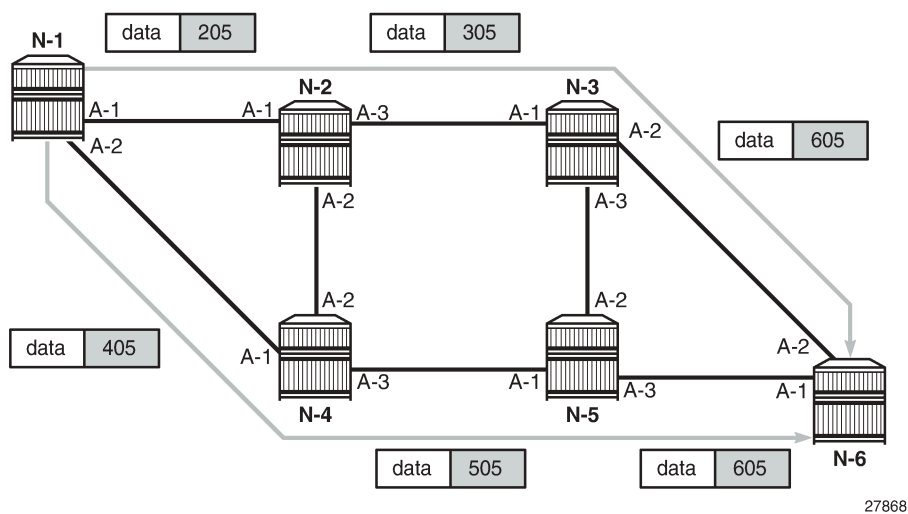
prefix, that is, the label programmed in the ILM, can be local to that router by the use of an offset label, referred to as a start label:

$$\text{Local Label (Prefix SID)} = \text{start-label} + \{\text{SID index}\}$$

The label operation in the network is very similar to LDP when operating in independent label distribution mode (RFC 5036), with the difference being that the label value used to forward a packet to each downstream router is computed by the upstream router based on the advertised prefix SID index using the above formula.

The following figure is an example of a router advertising its loopback address and the resulting packet label encapsulation throughout the network.

Figure 22: Packet label encapsulation using segment routing tunnel



Router N-6 advertises loopback 10.10.10.1/32 with a prefix index of 5. Routers N-1 to N-6 are configured with the same SID index range of [1,100] and an offset label of 100 to 600 respectively. The following are the actual label values programmed by each router for the prefix of PE2.

- N-6 has a start label value of 600 and programs an ILM with label 605.
- N-3 has a start label value of 300 and swaps incoming label 305 to label 605.
- N-2 has a start label value of 200 and swaps incoming label 205 to label 305.

Similar operations are performed by N-4 and N-5 for the bottom path.

N-1 has an SR tunnel to N-6 with two ECMP paths. It pushes label 205 when forwarding an IP or service packet to N-6 via downstream next hop N-2 and pushes label 405 when forwarding via downstream next hop N-4.

The CLI commands for configuring the prefix SID index range and offset label value for an IGP instance are as follows:

```
config>router>isis>segment-routing>prefix-sid-range {global | start-label label-value max-index index-value}
```

```
config>router>ospf>segment-routing>prefix-sid-range {global | start-label label-value max-index index-value}
```

There are two mutually exclusive modes of operation for the prefix SID range on the router: global mode and per-instance mode.

In the global mode of operation, the user configures the global value and the IGP instance assumes that the start label value is the lowest label value in the SRGB and the prefix SID index range size is equal to the range size of the SRGB. When one IGP instance selects the **global** option for the prefix SID range, all IGP instances on the system must do the same.

The user must shut down the segment routing context and disable the **prefix-sid-range** command in all IGP instances in order to change the SRGB. When the SRGB is changed, the user must re-enable the **prefix-sid-range** command. The SRGB range change fails if an already allocated SID index/label goes out of range.

In the per-instance mode of operation, the user partitions the SRGB into non-overlapping sub-ranges among the IGP instances. The user configures a subset of the SRGB by specifying the start label value and the prefix SID index range size. All resulting net label values (start-label + index) must be within the SRGB or the configuration fails. The 7705 SAR checks for overlaps of the resulting net label value range across IGP instances and strictly enforces no overlapping of the ranges.

The user must shut down the segment routing context of an IGP instance in order to change the SID index/label range of that IGP instance using the **prefix-sid-range** command. A range change fails if an already allocated SID index/label goes out of range.

The user can, however, change the SRGB without shutting down the segment routing context as long as it does not reduce the current per-IGP instance SID index/label range defined with the **prefix-sid-range** command. Otherwise, the user must shut down the segment routing context of the IGP instance and disable and re-enable the **prefix-sid-range** command.

Finally, the user brings up segment routing on the IGP instance by using the **no shutdown** command:

```
config>router>isis>segment-routing>no shutdown
config>router>ospf>segment-routing>no shutdown
```

This command fails if the user has not previously enabled the **advertise-router-capability** option in the IGP instance. Segment routing capability must be advertised to all routers in a particular domain so that routers that support the capability only program the node SID in the data path toward neighbors that also support it.

```
config>router>isis>advertise-router-capability {area | as}
config>router>ospf>advertise-router-capability {link | area | as}
```

The IGP segment routing extensions are area-scoped. The user must therefore configure the flooding scope to **area** in OSPF and to **area** or **as** in IS-IS; otherwise, performing a **no shutdown** of the segment-routing node will fail.

The **segment-routing** command and the **igp-shortcut** and **advertise-tunnel-link** are mutually exclusive under IGP, because an SR tunnel cannot resolve to an RSVP tunnel next hop.

IS-IS supports node SID indexes or labels on IPv4 and IPv6 interfaces, and OSPF supports node SID indexes or labels on IPv4 addresses only, because OSPFv3 does not support segment routing.

The user assigns a node SID index or label to the prefix representing the primary address of an IPv4 or IPv6 network interface of type **loopback** using one of the following commands:

```
config>router>isis>interface>ipv4-node-sid index value
config>router>ospf>area>interface>node-sid index value
config>router>isis>interface>ipv4-node-sid label value
```



```
config>router>ospf>area>interface>node-sid label value
```

```
config>router>isis>interface>ipv6-node-sid index value
```

```
config>router>isis>interface>ipv6-node-sid label value
```

Only a single node SID can be assigned to an interface. The secondary address of an IPv4 interface cannot be assigned a node SID index and does not inherit the SID of the primary IPv4 address. The same applies to the non-primary IPv6 addresses of an interface.

The above commands will fail if the network interface is not of type loopback or if the interface is defined in an IES or a VPRN context. Assigning the same SID index/label value to the same interface in two different IGP instances is not allowed within the same node.

The value of the label or index SID is taken from the range configured for the IGP instance. When using the global mode of operation, a new segment routing module checks that the same index or label value is not assigned to more than one loopback interface address. When using the per-instance mode of operation, this check is not required because the index, and therefore the label ranges, of IGP instances are not allowed to overlap.

### 5.1.10.1.1 Static adjacency SID values for an interface

For an individual adjacency, static values for the label can be configured for an IS-IS or OSPF interface. If the values are not configured, they are dynamically allocated by the system from the dynamic label range. Use the following CLI commands to configure labels for an IS-IS or OSPF interface:

```
config>router>isis>interface>ipv4-adjacency-sid label value
```

```
config>router>isis>interface>ipv6-adjacency-sid label value
```

```
config>router>ospf>area>interface>adjacency-sid label value
```

The SID for an individual adjacency is advertised in the IGP and is treated as local.

The label value must correspond to a label in the reserved label block referred to by the **srlb** command. A CLI error is generated if an invalid value is configured. For information about reserved label blocks, see the 7705 SAR MPLS Guide, "Reserved label blocks."

A static label value for an adjacency SID is persistent. Therefore, the P-flag of the Flags field in the Adj-SID sub-TLV is set to 1. All other flags are set as per the existing Adj-SID sub-TLV for dynamically allocated values.

By default, a dynamic adjacency SID is advertised for an interface. However, when a static adjacency SID value is configured, the dynamic adjacency SID is deleted and only the static adjacency SID is used. Changing an adjacency SID from dynamic (that is, **no adjacency-sid** or **no ipv4/ipv6 adjacency-sid**) to static or vice versa may result in traffic being dropped.

For a configured adjacency SID for an interface, a backup is calculated similar to a dynamic adjacency SID when the **sid-protection** command is enabled for that interface.

Configured adjacency SIDs are only supported on point-to-point interfaces.



## 5.1.10.2 Segment routing operational procedures

### 5.1.10.2.1 Prefix SID resolution for a segment routing mapping server

An SR-capable router, including a mapping server and its clients, attempts to resolve each received prefix SID to either an SR tunnel endpoint or an LDP tunnel endpoint as described below.

#### 5.1.10.2.1.1 IP prefix resolution

1. SPF calculates the next hops, up to the maximum value defined by the `config>router>ecmp max-ecmp-routes` command, to reach a destination node (see the 7705 SAR Router Configuration Guide, "IP Router Command Reference", "Router Commands" for more information about this command).
2. A prefix advertised by multiple nodes that are all reachable with the same cost inherits the next hops, up to the `max-ecmp-routes` defined value, from the advertising nodes.
3. The next-hop selection is based on:
  - the lowest next-hop router ID
  - the lowest interface index (for parallel links to same router ID)

Each next hop keeps a reference to the destination node from which it was inherited.

#### 5.1.10.2.1.2 Prefix SID resolution

1. For a specified prefix, the IGP selects the SID value among multiple advertised values according to the following preference order:
  - a. the local intra-area SID owned by this router
  - b. the prefix SID sub-TLV advertised within an IP reachability TLV

If multiple SIDs exist, the IGP selects the SID corresponding to the destination router or the ABR with the lowest system ID that is reachable using the first next hop of the prefix.
  - c. the IS-IS SID and Label Binding TLV from the mapping server

If multiple SIDs exist, the IGP selects the SID advertised by the mapping server with the lowest system ID.



**Note:** If a level 1/2 router acts as a mapping server and also readvertises the mapping server prefix SID from other mapping servers, the redistributed mapping server prefix SID is preferred by other routers resolving the prefix; this may result in the mapping server with the lowest system ID not being selected.

2. the selected SID is used with all ECMP next hops from step 1 of [IP prefix resolution](#) toward all destination nodes or ABR nodes that advertised the prefix.

If duplicate prefix SIDs exist after the above steps are completed, the first SID that is processed is programmed according to its corresponding prefix. Subsequent SIDs cause a duplicate SID trap and are not programmed. The corresponding prefixes are resolved and programmed normally using IP next hops.

### 5.1.10.2.1.3 SR tunnel programming

1. If the prefix SID is resolved from a prefix SID sub-TLV advertised within an IP reachability TLV, the SR ILM performs a swapping operation to an SR NHLFE as with regular SR tunnel resolution.
2. If the prefix SID is resolved from a mapping server advertisement, stitching to an LDP FEC is preferred over a swapping operation to an SR next hop.

The LDP FEC can be resolved via a static route or a route within an IS-IS instance. The IS-IS instance does not have to be the same as the IGP instance that advertised the mapping server prefix SID sub-TLV.

The SR next hop is only possible if a route is exported from another IGP instance into the local IGP instance without propagating the prefix SID sub-TLV with the route. Otherwise, when the prefix SID is propagated with the route, the resolution follows step 1 above.

### 5.1.10.2.2 Prefix advertisement and resolution

When segment routing is successfully enabled in an IS-IS instance or in OSPF, the router performs the following operations. See [Control protocol changes](#) for details of all TLVs and sub-TLVs for both IS-IS and OSPF protocols.

- Advertises the Segment Routing Capability sub-TLV to routers in all areas or levels of this IGP instance. However, only neighbors with which the IGP instance established an adjacency will interpret the SID and label range information and use it for calculating the label to swap to or push for a particular resolved prefix SID.
- Advertises the assigned index for each configured node SID in the new prefix SID sub-TLV with the N-flag (node SID flag) set. The segment routing module then programs the incoming label map (ILM) with a pop operation for each local node SID in the data path.
- Automatically assigns and advertises an adjacency SID label for each formed adjacency over a network IP interface in the new Adjacency SID sub-TLV. The following points should be considered.
  - An adjacency SID is advertised for both numbered and unnumbered network IP interfaces.
  - An adjacency SID is not supported for parallel adjacencies between two IGP neighbors.
  - An adjacency SID is not advertised for an IES interface because access interfaces do not support MPLS.
  - The adjacency SID must be unique per instance and per adjacency. Furthermore, IS-IS multi-topology 0 (MT 0, IPv4 unicast) can establish an adjacency for both IPv4 and IPv6 address families over the same link, and in that case, a different adjacency SID is assigned to each next hop. However, the existing IS-IS implementation assigns a single Protect-Group ID (PG-ID) to the adjacency; therefore, when the state machine of a BFD session tracking the IPv4 or IPv6 next hop times out, an action is triggered for the prefixes of both address families over that adjacency.

The segment routing module programs the incoming label map (ILM) with a swap to an implicit null label operation for each advertised adjacency SID.

- Resolves received prefixes, and if a prefix SID sub-TLV exists, the segment routing module programs the ILM with a swap operation and an LTN with a push operation, both pointing to the primary/LFA NHLFE. An SR tunnel is also added to the TTM. If a node SID resolves over an IES interface, the data path is not programmed and a trap is raised. Therefore, only next hops of an ECMP set corresponding to network IP interfaces are programmed in the data path; next hops corresponding to IES interfaces

are not programmed. If the user configures the interface as network on one side and IES on the other side, MPLS packets for the SR tunnel received on the access side are dropped.

- LSA filtering, causing SIDs not to be sent in one direction which means some node SIDs are resolved in parts of the network upstream of the advertisement suppression.

When the user enables segment routing in an IGP instance, the main SPF and LFA SPF are computed normally and the primary next hop and LFA backup next hop for a received prefix are added to the RTM without the label information advertised in the prefix SID sub-TLV. In all cases, the SR tunnel is not added into the RTM.

### 5.1.10.2.3 Error and resource exhaustion handling

When the prefix corresponding to a node SID is being resolved, the following procedures are followed.

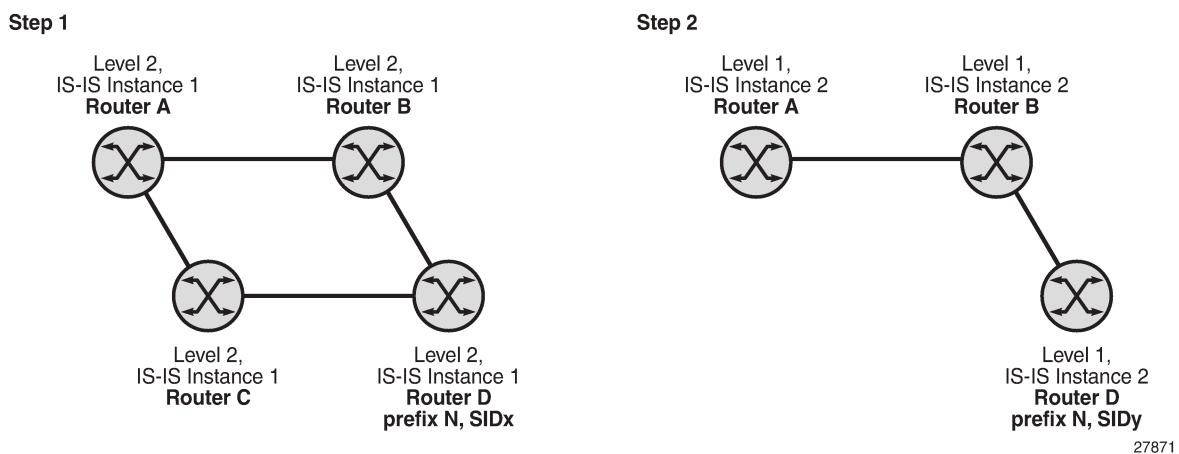
#### Procedure 1: providing support of multiple topologies for the same destination prefix

The 7705 SAR supports assigning different prefix SID indexes and labels to the same prefix in different IGP instances. While other routers that receive these prefix SIDs program a single route into the RTM, based on the winning instance ID as per the RTM route type preference, the 7705 SAR adds two tunnels to this destination prefix in the TTM. This provides for the support of multiple topologies for the same destination prefix.

Example:

In two different instances (level 2, IS-IS instance 1 and level 1, IS-IS instance 2), Router D has the same prefix destination with different SIDs (SIDx and SIDy); see the following figure.

Figure 23: Programming multiple tunnels to the same destination



Assume that the following route type preference in the RTM and tunnel type preference in the TTM are configured:

- ROUTE\_PREF\_ISIS\_L1\_INTER (RTM) 15
- ROUTE\_PREF\_ISIS\_L2\_INTER (RTM) 18

- ROUTE\_PREF\_SR\_ISIS\_TTM 10



**Note:** The TTM tunnel type preference is not used by the SR module. It is put in the TTM and is used by other applications such as VPRN autobind and BGP shortcuts to select a TTM tunnel.

1. Router A performs the following resolution within the single IS-IS instance 1, level 2. All metrics are the same, and ECMP = 2.
  - For prefix N, the RTM entry is:
    - prefix N
    - nhop1 = B
    - nhop2 = C
    - preference 18
  - For prefix N, the SR tunnel TTM entry is:
    - tunnel-id 1: prefix N-SIDx
    - nhop1 = B
    - nhop2 = C
    - tunl-pref 10
2. Add IS-IS instance 2 (level 1) in the same setup, but in routers A, B, and C only. Router A performs the resolution.
  - For prefix N, the RTM entry is:
    - prefix N
    - nhop1 = B
    - preference 15The RTM prefers level 1 route over level 2 route.
  - For prefix N, there are two SR tunnel entries in the TTM:
    - SR entry for level 2:
      - tunnel-id 1: prefix N-SIDx
      - nhop1 = B
      - nhop2 = C
      - tunl-pref 10
    - SR entry for level 1:
      - tunnel-id 2: prefix N-SIDy

## Procedure 2: resolving received SID indexes or labels to different routes of the same prefix within the same IGP instance

Two variations of this procedure can occur.

1. If the 7705 SAR does not allow assigning the same SID index or label to different routes of the same prefix within the same IGP instance, it resolves only one SID index or label if it is received from another SR implementation and based on the RTM active route selection.

2. If the 7705 SAR does not allow assigning different SID indexes or labels to different routes of the same prefix within the same IGP instance, it resolves only one SID index or label if received from another SR implementation and based on the RTM active route selection.

The selected SID will be used for ECMP resolution to all neighbors. If the route is inter-area and the conflicting SIDs are advertised by different ABRs, ECMP toward all ABRs uses the selected SID.

### Procedure 3: checking for SID errors before programming ILM and NHLFE

If any of the following conditions are true, the router logs a trap and generates a syslog error message and will not program the ILM and NHLFE for the prefix SID:

- the received prefix SID index falls outside the locally configured SID range
- one or more resolved ECMP next hops for a received prefix SID did not advertise SR Capability sub-TLV
- the received prefix SID index falls outside the advertised SID range of one or more resolved ECMP next hops

### Procedure 4: programming ILM/NHLFE for duplicate prefix SID indexes/labels for different prefixes

Two variations of this procedure can occur.

1. For received duplicate prefix SID indexes or labels for different prefixes within the same IGP instance, the router:
  - programs ILM/NHLFE for the first prefix SID
  - logs a trap and a syslog error message
  - does not program the subsequent prefix SID in the data path
2. For received duplicate prefix SID indexes for different prefixes across IGP instances, there are two options.
  - In the global SID index range mode of operation, the resulting ILM label values are the same across the IGP instances. The router:
    - programs ILM/NHLFE for the prefix of the winning IGP instance based on the RTM route type preference
    - logs a trap and a syslog error message
    - does not program the subsequent prefix SIDs in the data path
  - In the per-instance SID index range mode of operation, the resulting ILM label will have different values across the IGP instances. The router programs ILM/NHLFE for each prefix as expected.

### Procedure 5: programming ILM/NHLFE for the same prefix across IGP instances

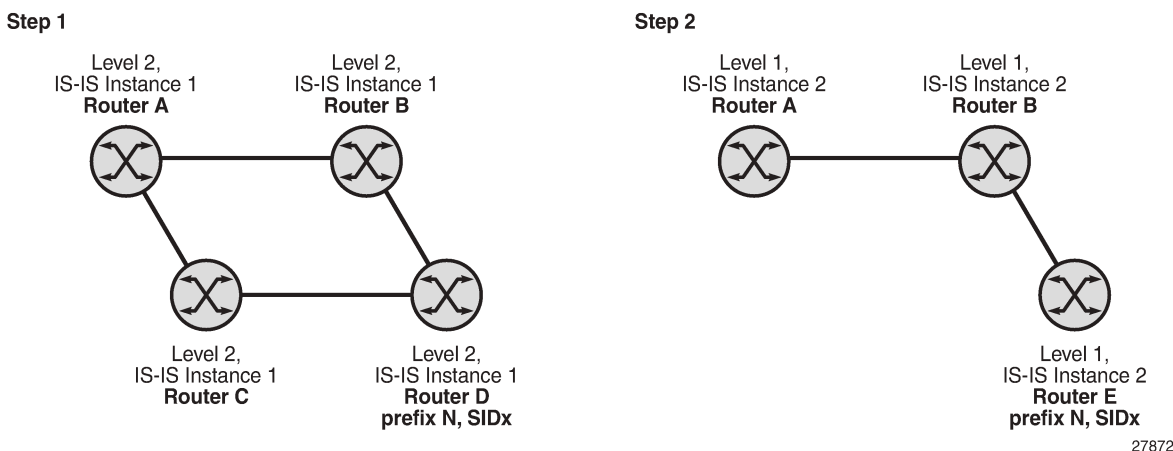
The behavior in the case of a global SID index range is illustrated by the IS-IS example in [Figure 24: Handling of same prefix and SID in different IS-IS instances](#).

In the global SID index range mode of operation, the resulting ILM label values are the same across the IGP instances. The router programs ILM/NHLFE for the prefix of the winning IGP instance based on the

RTM route type preference. The router logs a trap and a syslog error message, and does not program the other prefix SIDs in the data path.

In the per-instance SID index range mode of operation, the resulting ILM label has different values across the IGP instances. The router programs ILM/NHLFE for each prefix as expected.

Figure 24: Handling of same prefix and SID in different IS-IS instances



Assume that the following route type preference in the RTM and tunnel type preference in the TTM are configured:

- ROUTE\_PREF\_ISIS\_L1\_INTER (RTM) 15
- ROUTE\_PREF\_ISIS\_L2\_INTER (RTM) 18
- ROUTE\_PREF\_SR\_ISIS\_TTM 10



**Note:** The TTM tunnel type preference is not used by the SR module. It is put in the TTM and is used by other applications such as VPRN autobind and BGP shortcuts to select a TTM tunnel.

1. Router A performs the following resolution within the single IS-IS instance 1, level 2. All metrics are the same, and ECMP = 2.
  - For prefix N, the RTM entry is:
    - prefix N
    - nhop1 = B
    - nhop2 = C
    - preference 18
  - For prefix N, the SR tunnel TTM entry is:
    - tunnel-id 1: prefix N-SIDx
    - nhop1 = B
    - nhop2 = C
    - tunl-pref 10
2. Add IS-IS instance 2 (level 1) in the same setup, but in routers A, B, and E only. Router A performs the resolution.

- For prefix N, the RTM entry is:
  - prefix N
  - nhop1 = B
  - preference 15The RTM prefers level 1 route over level 2 route.
- For prefix N, there is one SR tunnel entry for level 2 in the TTM:
  - tunnel-id 1: prefix N-SIDx
  - nhop1 = B
  - nhop2 = C
  - tunl-pref 10

### Procedure 6: handling ILM resource exhaustion while assigning a SID index/label

If the system exhausted an ILM resource while assigning a SID index/label to a local loopback interface, index allocation fails and an error is returned in the CLI. In addition, the router logs a trap and generates a syslog error message.

### Procedure 7: handling ILM, NHLFE, or other IOM or CSM resource exhaustion while resolving or programming a SID index/label

If the system exhausted an ILM, NHLFE, or any other IOM or CSM resource while resolving and programming a received prefix SID or programming a local adjacency SID, the following occurs.

- The IGP instance goes into overload and a trap and syslog error message are generated.
- The segment routing module deletes the tunnel.

The user must manually clear the IGP overload condition after freeing resources. After the IGP is brought back up, it attempts to program at the next SPF all tunnels that previously failed the programming operation.

## 5.1.10.3 Segment routing tunnel management

The segment routing module adds to the TTM a shortest path SR tunnel entry for each resolved remote node SID prefix and programs the data path with the corresponding LTN with the push operation pointing to the primary and LFA backup NHLFEs. The LFA backup next hop for a prefix that was advertised with a node SID will only be computed if the **loopfree-alternates** option is enabled in the IS-IS instance or in OSPF. The resulting SR tunnel that is populated in the TTM is automatically protected with FRR when an LFA backup next hop exists for the prefix of the node SID.

With ECMP, a maximum of eight primary next hops (NHLFEs) are programmed for the same tunnel destination per IGP instance. ECMP and LFA next hops are mutually exclusive.

The default preference for shortest path SR tunnels in the TTM is set lower than LDP tunnels but higher than BGP tunnels to allow controlled migration of customers without disrupting their current deployment when they enable segment routing. The following is the setting of the default preferences for the various

tunnel types. This includes the preference of both SR tunnels based on shortest path (referred to as SR-ISIS and SR-OSPF).

The global default TTM preference for the tunnel types is as follows:

ROUTE_PREF_RSVP	7
ROUTE_PREF_SR_TE	8
ROUTE_PREF_LDP	9
ROUTE_PREF_SR_OSPF_TTM	10
ROUTE_PREF_SR_ISIS_TTM	11
ROUTE_PREF_BGP_TTM	12
ROUTE_PREF_GRE	255

The default value for SR-ISIS is the same regardless of whether one or more IS-IS instances programmed a tunnel for the same prefix. The selection of an SR tunnel in this case is based on the lowest IGP instance ID.

The TTM preference is used for BGP shortcuts, VPRN autobind, or BGP transport tunnel when the tunnel binding commands are configured to the **any** value, which parses the TTM for tunnels in the protocol preference order. The user can choose to either accept the global TTM preference or explicitly list the tunnel types to be used. When the tunnel types are listed explicitly, the TTM preference is still used to select one type over the other. In both cases, a fallback to the next preferred tunnel type is performed if the selected one fails. A reversion to a more preferred tunnel type is performed as soon as one is available. See [BGP label route resolution using segment routing tunnel](#), and [Service packet forwarding with segment routing](#) for the detailed service and shortcut binding CLI commands.

For SR-ISIS and SR-OSPF, the user can configure the preference of each specific IGP instance away from the above default values.

**CLI syntax:**

```
config>router>isis>segment-routing>tunnel-table-pref preference
config>router>ospf>segment-routing>tunnel-table-pref preference
```



**Note:** The preference of the SR-TE LSP is not configurable and is the second most preferred tunnel type after RSVP-TE. The preference is the same whether the SR-TE LSP was resolved in IS-IS or OSPF.

### 5.1.10.3.1 Tunnel MTU determination

The MTU of an SR tunnel populated into the TTM is determined as in the same way as the MTU of an IGP tunnel (for example, LDP LSP), based on the outgoing interface MTU minus the label stack size. Segment routing, however, supports remote LFA, which programs an LFA backup next hop, adding another label to the tunnel for a total of two labels.

The following commands are used to configure the MTU of all SR tunnels within each IGP instance:

**CLI syntax:**

```
config>router>isis (ospf)>segment-routing>tunnel-mtu bytes
```



There is no default value for this command. If the user does not configure an SR tunnel MTU, the MTU, in bytes, is fully determined by IGP as follows:

$$SR\_Tunnel\_MTU = MIN \{Cfg\_SR\_MTU, IGP\_Tunnel\_MTU - (1 + frr-overhead) \times 4\}$$

where

- *Cfg\_SR\_MTU* is the MTU configured by the user for all SR tunnels within an IGP instance using the **tunnel-mtu** command. If no value is configured by the user, the SR tunnel MTU is fully determined by the IGP interface calculation described in the following bullet point
- *IGP\_Tunnel\_MTU* is the minimum of the IS-IS or OSPF interface MTU among all the ECMP paths or among the primary and LFA backup paths of this SR tunnel
- *frr-overhead* is set to 1 if the **segment-routing** and **remote-lfa** options are enabled in the IGP instance. Otherwise, it is set to 0.

The SR tunnel MTU is dynamically updated whenever any of the above parameters used in its calculation changes. This includes if the set of the tunnel next hops changes or the user changes the configured SR MTU or interface MTU value.



**Note:** If fragmentation is used for IP packets forwarded in the GRT or in a VPRN over an SR shortest path tunnel, the IOM always deducts the worst-case MTU (5 labels, or 6 labels if the hash label feature is enabled) from the outgoing interface MTU when deciding whether to fragment the packet. In this case, the above formula is not used.

#### 5.1.10.4 Remote LFA with segment routing

Remote LFA for segment routing supports both link protection and node protection. For information about remote LFA for node protection, see [Node protection support in remote LFA and TI-LFA](#).

The remote LFA next-hop calculation by the IGP LFA SPF is enabled with the following command:

##### CLI syntax:

```
config>router>isis>loopfree-alternates>remote-lfa
config>router>ospf>loopfree-alternates>remote-lfa
```

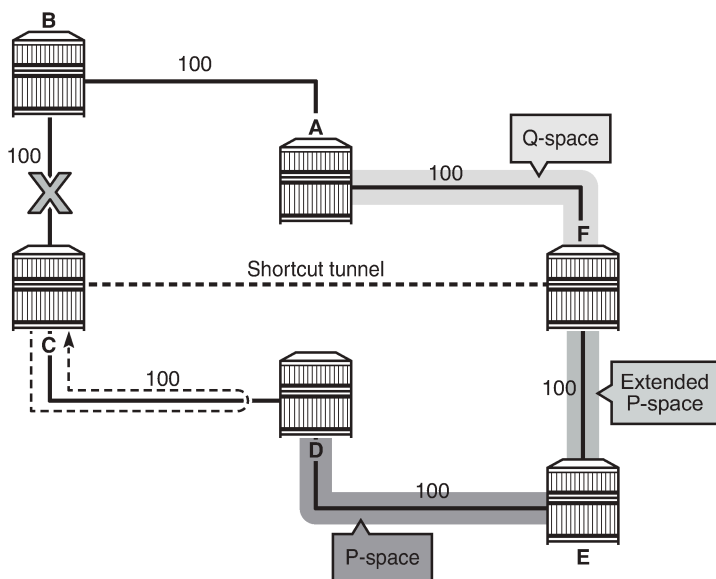
SPF performs the remote LFA additional computation following the regular LFA next-hop calculation when both of the following conditions are met:

- the **remote-lfa** option is enabled in an IGP instance
- the LFA next-hop calculation did not result in protection for one or more prefixes resolved to an interface

Remote LFA extends the protection coverage of LFA-FRR to any topology by automatically computing and establishing or tearing down shortcut tunnels, also referred to as repair tunnels, to a remote LFA node that puts the packets back into the shortest path without looping them back to the node that forwarded them over the repair tunnel. A repair tunnel can, in theory, be an RSVP-TE LSP, an LDP-in-LDP tunnel, or an SR tunnel. On the 7705 SAR, this feature is restricted to using an SR repair tunnel to the remote LFA node.

The remote LFA algorithm for link protection is described in RFC 7490, *Remote Loop-Free Alternate (LFA) Fast Reroute (FRR)*. Unlike the regular LFA calculation, which is calculated per prefix, the LFA algorithm for link protection is a per-link LFA SPF calculation. The algorithm provides protection for all destination prefixes which share the protected link by using the neighbor on the other side of the protected link as a proxy for all the destinations. An example is shown in the following figure.

Figure 25: Remote LFA algorithm



27869

When the LFA SPF in node C computes the per-prefix LFA next hop, prefixes that use link C-B as the primary next hop have no LFA next hop due to the ring topology. If node C used node link C-D as a backup next hop, node D would loop a packet back to node C. Remote LFA then runs the following algorithm, referred to as the “PQ Algorithm” in RFC 7490:

1. The algorithm computes the extended P space of node C with respect to link C-B: the set of nodes reachable from node C without any path transiting the protected link (link C-B). This yields nodes D, E, and F.

The determination of the extended P space by node C uses the same computation as regular LFA by running SPF on behalf of each of the neighbors of C.



**Note:** RFC 7490 initially introduced the concept of P space, which would have excluded node F because, from the node C perspective, node C has a couple of ECMP paths, one of which goes via link C-B. However, because the remote LFA next hop is activated when link C-B fails, this rule can be relaxed and node F can be included, which then yields the extended P space.

The user can limit the search for candidate P nodes to reduce the number of SPF calculations in topologies where many eligible P nodes can exist. A CLI command is provided to configure the maximum IGP cost from node C for a P node to be eligible:

- `config>router>isis>loopfree-alternates>remote-lfa max-pq-cost value`
- `config>router>ospf>loopfree-alternates>remote-lfa max-pq-cost value`

2. The algorithm computes the Q space of node B with respect to link C-B: the set of nodes from which the destination proxy (node B) can be reached without any path transiting the protected link (link C-B).

The Q-space calculation is effectively a reverse SPF on node B. In general, one reverse SPF is run on behalf of each of the neighbors of C to protect all destinations resolving over the link to the neighbor. This yields nodes F and A in the example in [Figure 25: Remote LFA algorithm](#).

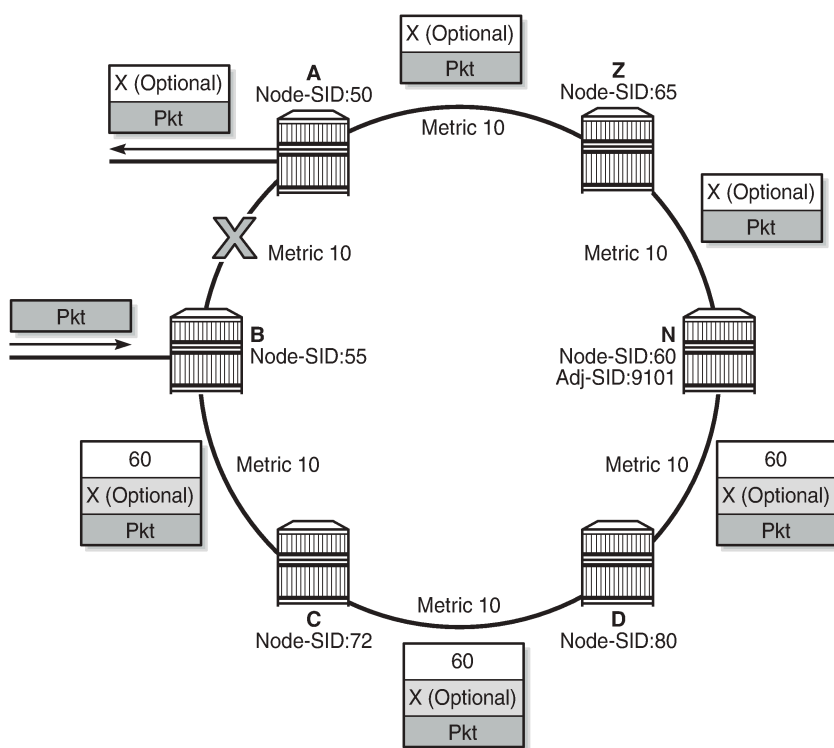
The user can limit the search for candidate Q nodes to reduce the amount of SPF calculations in topologies where many eligible Q nodes can exist. The above CLI command is also used to configure the maximum IGP cost from node C for a Q node to be eligible.

- The algorithm selects the best alternate node: this is the intersection of extended P and Q spaces. The best alternate node or PQ node is node F in the example in [Figure 25: Remote LFA algorithm](#). From node F onwards, traffic follows the IGP shortest path.

If many PQ nodes exist, the lowest IGP cost from node C is used to narrow down the selection, and if more than one PQ node remains, the node with the lowest router ID is selected.

The details of the label stack encoding when the packet is forwarded over the remote LFA next hop is shown in the following figure.

Figure 26: Remote LFA next hop in segment routing



27870

The label corresponding to the node SID of the PQ node is pushed on top of the original label of the SID of the resolved destination prefix. If node C has resolved multiple node SIDs corresponding to different prefixes of the selected PQ node, it pushes the lowest node SID label on the packet when forwarding the packets over the remote LFA backup next hop.

If the PQ node is also the advertising router for the resolved prefix, the label stack is compressed in some cases, depending on the IGP.

- In IS-IS, the label stack is always reduced to a single label, which is the label of the resolved prefix owned by the PQ node.
- In OSPF, the label stack is reduced to the single label of the resolved prefix when the PQ node advertised a single node SID. If the PQ node advertised a node SID for multiple loopback interfaces

within OSPF, the label stack is reduced to a single label only if the SID of the resolved prefix is the lowest SID value.

The following rules and limitations apply to the remote LFA implementation.

- LFA policy is currently supported for IP next hops only. It is not supported for tunnel next hops when IGP shortcuts are used for LFA backup. Remote LFA is also a tunnel next hop; therefore, a user-configured LFA policy is not applied in the selection of a remote LFA backup next hop when multiple candidates are available.
- As a result, if an LFA policy is applied and does not find an LFA IP next hop for a set of prefixes, the remote LFA SPF runs a search for a remote LFA next hop for the same prefixes. The selected remote LFA next hops, if found, may not satisfy the LFA policy constraints.
- If the user excludes a network IP interface from being used as an LFA next hop using the CLI command **loopfree-alternate-exclude** under the IS-IS or OSPF interface context, the interface is also excluded from being used as the outgoing interface for a remote LFA tunnel next hop.
- As with the regular LFA algorithm, the remote LFA algorithm computes a backup next hop to the ABR advertising an inter-area prefix and not to the destination prefix.

### 5.1.10.5 Topology-independent LFA

The topology-independent LFA (TI-LFA) feature improves the protection coverage of a network topology by computing and automatically instantiating a repair tunnel to a Q node that is not in the shortest path from the computing node. The repair tunnel uses the shortest path to the P node and a source-routed path from the P node to the Q node.

In addition, the TI-LFA algorithm selects the backup path that matches the post-convergence path. This helps with capacity planning in the network because traffic always flows on the same path when transitioning to the FRR next hop and then to the new primary next hop.

At a high level, the TI-LFA link-protection algorithm searches for the closest Q node to the computing node and then selects the closest P node to this Q node, up to a maximum number of labels. This is performed on each of the post-convergence paths to each destination node or prefix.

TI-LFA supports both link protection and node protection. For information about node protection, see [Node protection support in remote LFA and TI-LFA](#).

#### 5.1.10.5.1 TI-LFA configuration

TI-LFA can be enabled in OSPF or in an IS-IS instance using the following command:

- **config>router>ospf>loopfree-alternates>ti-lfa [max-sr-frr-labels value]**
- **config>router>isis>loopfree-alternates>ti-lfa [max-sr-frr-labels value]**

When the **ti-lfa** option is enabled in OSPF, it provides a TI-LFA link-protect backup for an SR-OSPF IPv4 tunnel or for an IPv4 SR-TE LSP. See more details of the applicability of the various LFA options in [LFA protection option applicability](#).

When the **ti-lfa** option is enabled in IS-IS, it provides a TI-LFA link-protect backup path in S-IS multi-topology 0 (MT 0) for an SR-ISIS IPv4 or SR-ISIS IPv6 tunnel (node SID and adjacency SID), or for an IPv4 SR-TE LSP. See more details of the applicability of the various LFA options in [LFA protection option applicability](#).

The **max-sr-frr-labels** parameter limits the search for the LFA backup next hop:

- 0 – the IGP LFA SPF restricts the search to a TI-LFA backup next hop that does not require a repair tunnel, meaning that the P node and Q node are the same and match a neighbor. This is also the case when both P and Q nodes match the advertising router for a prefix.
- 1 to 3 – the IGP LFA SPF widens the search to include a repair tunnel to a P node that is connected to the Q nodes with zero to two hops for a total of three labels maximum: one node SID to the P node and two adjacency SIDs from the P node to the Q node. If the P node is a neighbor of the computing node, its node SID is compressed, meaning that up to three adjacency SIDs can separate the P and Q nodes.
- 2 (default) – corresponds to a repair tunnel to a non-adjacent P node that is adjacent to the Q node. If the P node is a neighbor of the computing node, the node SID of the P node is compressed and the default value of two labels corresponds to two adjacency SIDs between the P and Q nodes.

If the user attempts to change the **max-sr-frr-labels** parameter to a value that results in a change to the computed FRR overhead, the IGP checks that all SR-TE LSPs can properly account for the overhead based on the configuration of the LSP **max-sr-labels** and **additional-frr-labels** parameter values; otherwise, the change is rejected.

The FRR overhead is computed by the IGP and its value is set as follows:

- 0 if **segment-routing** is disabled in the IGP instance
- 0 if **segment-routing** is enabled but **remote-lfa** is disabled and **ti-lfa** is disabled
- 1 if **segment routing** is enabled and **remote-lfa** is enabled but **ti-lfa** is disabled, or if **segment-routing** is enabled, **remote-lfa** is enabled, and **ti-lfa** is enabled but **ti-lfa max-sr-frr-labels labels** is set to 0
- to the value of **ti-lfa max-sr-frr-labels labels**, if **segment-routing** is enabled and **ti-lfa** is enabled, regardless of whether **remote-lfa** is enabled or disabled

The LFA commands enable the base LFA feature with the **loopfree-alternates** command, and optionally add remote LFA with the **remote-lfa** option and TI-LFA with the **ti-lfa** option. The behavior when one or more of these options is enabled is explained in [TI-LFA link-protect operation](#). For more information about remote LFA operation, see [Node protection support in remote LFA and TI-LFA](#).

## 5.1.10.5.2 TI-LFA link-protect operation

### 5.1.10.5.2.1 LFA protection option applicability

Depending on the parameters configured for the **loopfree-alternates** command, the LFA SPF in an IGP instance runs the algorithms in the following order.

1. The algorithm first computes a regular LFA for each node and prefix. In this step, a computed backup next hop satisfies any applied LFA policy. This backup next hop protects the specific prefix or node in the context of IP FRR, SR FRR, or SR-TE FRR.
2. Next, the algorithm always follows with the TI-LFA if the **ti-lfa** command is enabled for all prefixes and nodes regardless of the outcome of the first step.

With SR FRR and SR-TE FRR, the TI-LFA next hop protects the node SID of that prefix and protects any adjacency SID terminating on the node SID of that prefix.

3. Finally, the algorithm runs remote LFA only for the next hop of prefixes and nodes that remain unprotected after the first and second steps if the **remote-lfa** command is enabled.

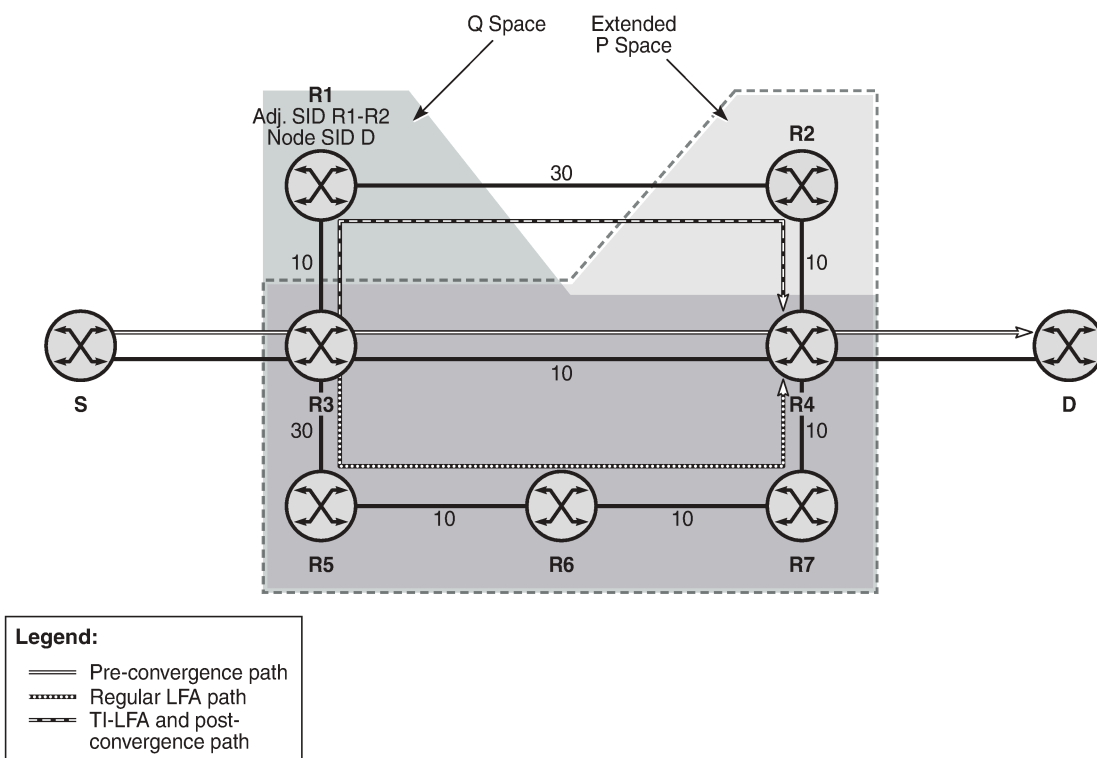
When protecting an adjacency SID, a parallel ECMP adjacency takes precedence over any other type of LFA backup path. Applying the above algorithm applicability rules results in the following selection:

- adjacency SID of an alternate ECMP next hop
- TI-LFA backup next hop
- LFA backup next hop
- remote LFA backup next hop

### 5.1.10.5.2.2 TI-LFA algorithm

At a high level, the TI-LFA link-protection algorithm searches for the closest Q node to the computing node and then selects the closest P node to this Q node, up to the number of labels corresponding to the value of **ti-lfa max-sr-frr-labels labels**, on each of the post-convergence paths to each destination node or prefix. The following figure shows a topology where router R3 computes a TI-LFA next hop for protecting link R3-R4.

Figure 27: Selecting link-protect TI-LFA backup path



27874

For each destination node D:

1. The algorithm computes the post-convergence SPF on the topology without the protected link. In the figure, R3 finds a single post-convergence path to destination D via R1. The post-convergence SPF does not include IGP shortcut tunnels, unless advertised as forwarding adjacencies.
2. The algorithm computes the extended P space of R3 with respect to protected link R3-R4 on the post-convergence paths.

This is the set of nodes  $Y_i$  in the post-convergence paths that are reachable from R3 neighbors without any path transiting the protected link R3-R4.

R3 computes an LFA SPF rooted at each of its neighbors within the post-convergence paths, that is, R1, using the following equation:

$$\text{Distance\_opt}(R1, Y_i) < \text{Distance\_opt}(R1, R3) + \text{Distance\_opt}(R3, Y_i)$$

where "Distance\_opt( $A, B$ )" is the shortest distance between two nodes,  $A$  and  $B$ . The extended P-space calculation yields only node R1.

3. The algorithm computes the Q space of R3 with respect to protected link R3-R4 in the post-convergence paths.

This is the set of nodes  $Z_i$  in the post-convergence paths from which the neighbor node R4 of the protected link, acting as a proxy for all destinations  $D$ , can be reached without any path transiting the protected link R3-R4.

$$\text{Distance\_opt}(Z_i, R4) < \text{Distance\_opt}(Z_i, R3) + \text{Distance\_opt}(R3, R4)$$

The Q-space calculation yields nodes R2 and R4.

This is the same computation of the Q space performed by the remote LFA algorithm, except that the TI-LFA Q-space computation is performed only on the post-convergence.

4. For each post-convergence path, the algorithm searches for the closest Q node and selects the closest P node to this Q node, up to the number of labels corresponding to the value of **ti-lfa max-sr-frr-labels labels**.

In the topology in [Figure 27: Selecting link-protect TI-LFA backup path](#), there is a single post-convergence path, and a single P node (R1), and the closest of the two found Q nodes to the P node is R2.

R3 installs the repair tunnel to the P-Q set and includes the node SID of R1 and the adjacency SID of the adjacency over link R1-R2 in the label stack. Because the P node R1 is a neighbor of the computing node R3, the node SID of R1 is not needed and the label stack of the repair tunnel is compressed to the adjacency SID over link R1-R2 as shown in the figure.

When a P-Q set is found on multiple ECMP post-convergence paths, the following selection rules are applied, in ascending order, to select a set from a single path:

- a. the lowest number of labels
- b. the lowest next-hop router ID
- c. the lowest interface index if the same next-hop router ID is the same

If multiple links with adjacency SIDs exist between the selected P node and the selected Q node, the following rules are used to select one link:

- a. the adjacency SID with the lowest metric
- b. the adjacency SID with the lowest SID value if the lowest metric is the same

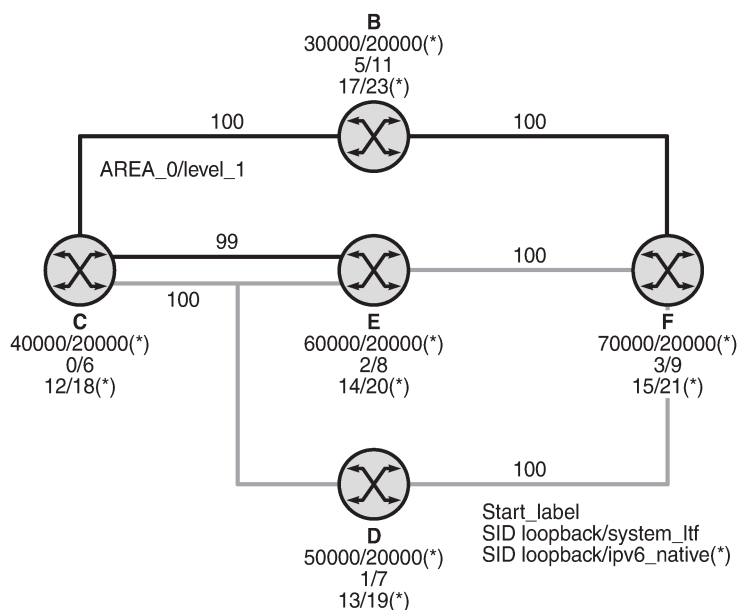
### 5.1.10.5.2.3 TI-LFA feature interactions and limitations

The following are feature interactions and limitations of TI-LFA link protection:

- Enabling the **ti-lfa** option in an IS-IS instance or for OSPF overrides the user configuration of the **loopfree-alternate-exclude** command under the interface context in the IGP instance. In other words, the TI-LFA SPF uses that interface as a backup next hop if it matches the post-convergence next hop.

- Any prefix excluded from LFA protection using the `loopfree-alternates>exclude>prefix-policy prefix-policy` command under the IGP instance context is also excluded from TI-LFA.
- Because the post-convergence SPF does not use paths transiting on a node in IS-IS overload, the TI-LFA backup path automatically will not transit on such a node.
- As with remote LFA, a user-configured LFA policy is not applied in the selection of a TI-LFA backup next hop when multiple candidates are available.
- IES interfaces are skipped in TI-LFA computations because they do not support segment routing with MPLS encapsulation. If the only found TI-LFA backup next hop matches an IES interface, the IGP will treat this as if there were no TI-LFA backup paths and will fall back to using either a remote LFA or regular LFA backup path as per the selection rules in [LFA protection option applicability](#).
- When the TI-LFA feature provides link protection only, if the protected link is a broadcast interface, the TI-LFA algorithm only guarantees protection of that link and not of the pseudonode corresponding to that shared subnet. In other words, if the pseudonode is in the post-convergence path, the TI-LFA backup path may still traverse the pseudonode. For example, node E in [Figure 28: TI-LFA backup path via a pseudonode](#) computes a TI-LFA backup path to destination D via E-C-PN-D because it is the post-convergence path when excluding link E-PN from the topology. This TI-LFA backup does not protect against the failure of the pseudonode (PN).

Figure 28: TI-LFA backup path via a pseudonode



27875

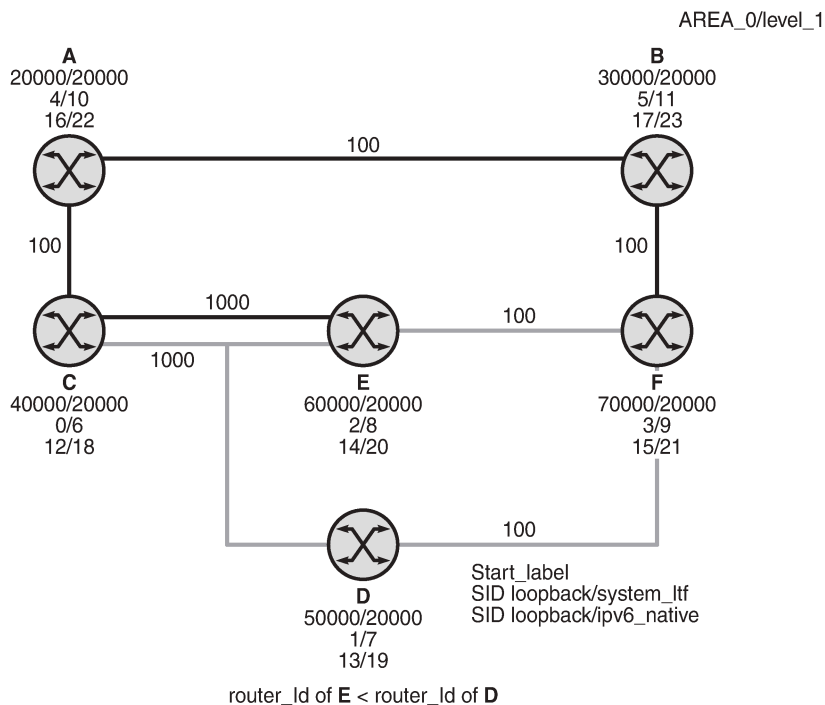
- When the computing router selects an adjacency SID among a set of parallel adjacencies between the P and Q nodes, the selection rules in step 4 of [TI-LFA algorithm](#) are used. However, these rules may not yield the same interface that the P node would have selected in its post-convergence SPF because the latter is based on the lowest value of the locally managed interface index.

For example, node A in [Figure 29: Parallel adjacencies between P and Q nodes](#) computes the link-protect TI-LFA backup path for destination node E as path A-C-E, where C is the P node and E is the Q node and destination. C has a pair of adjacency SIDs with the same metric to E. Node A selects the adjacency over the point-to-point link C-E because it has the lowest SID value, but node C may select



the interface C-PN in its post-convergence path calculation if that interface has a lower interface index than point-to-point link C-E.

Figure 29: Parallel adjacencies between P and Q nodes



27876

### 5.1.10.5.3 Data path support

The TI-LFA repair tunnel can have a maximum of three additional labels pushed in addition to the label of the destination node or prefix. The user can set a lower maximum value for the additional FRR labels by configuring the **ti-lfa max-sr-frr-labels labels** option. The default value is 2.

The data path models the backup path like an SR-TE LSP and therefore uses a super-NHLFE pointing to the NHLFE of the first hop in the repair tunnel. That first hop corresponds to either an adjacency SID or a node SID of the P node.

There is a special case where the P node is adjacent to the node computing the TI-LFA backup, and the Q node is the same as the P node or adjacent to the P node. In this case, the data path at the computing router pushes either zero labels or one label for the adjacency SID between the P and Q nodes. The backup path uses a regular NHLFE in this case as in base LFA or remote LFA. [Figure 27: Selecting link-protect TI-LFA backup path](#) shows an example of a single label in the backup NHLFE.

### 5.1.10.6 Node protection support in remote LFA and TI-LFA

The 7705 SAR supports extensions to the LFA algorithm so that remote LFA and TI-LFA can be used for node protection in addition to link protection.

When node protection is enabled, the router prefers a node-protect repair tunnel over a link-protect repair tunnel for a prefix if both tunnels are found in the remote LFA or TI-LFA SPF computations; however, the SPF computation may only find a link-protect repair tunnel for prefixes owned by the protected node.

### 5.1.10.6.1 Configuring remote LFA and TI-LFA for node protection

The node protection calculation for remote LFA and TI-LFA is enabled with the following commands:

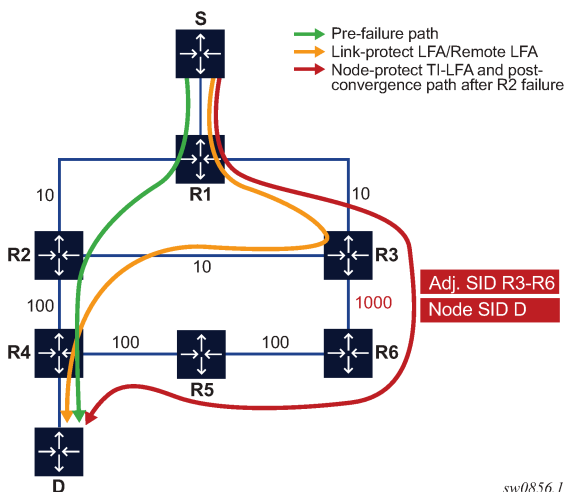
- `config>router>isis>loopfree-alternates>remote-lfa [max-pq-cost value]>node-protect [max-pq-nodes value]`
- `config>router>isis>loopfree-alternates>ti-lfa [max-sr-frr-labels value]>node-protect`
- `config>router>ospf>loopfree-alternates>remote-lfa>node-protect [max-pq-cost value]`
- `config>router>ospf>loopfree-alternates>ti-lfa [max-sr-frr-labels value]>node-protect`

The **max-pq-nodes** parameter in the **remote-lfa** command controls the maximum number of candidate PQ nodes found in the LFA SPFs for which the node protection check is performed. The node-protect condition means that the router must run the original remote LFA algorithm for link protection plus one extra forward SPF on behalf of each PQ node found, potentially after applying the **max-pq-cost** parameter, to verify that the path from the PQ node to the destination does not traverse the protected node. Setting the **max-pq-nodes** parameter to a lower value means that the LFA SPFs use less computation time and resources; however, this may result in not finding a node-protect repair tunnel.

### 5.1.10.6.2 TI-LFA node-protect operation

The 7705 SAR supports the node-protect extensions to the TI-LFA algorithm as described in *draft-bashandy-rtgwg-segment-routing-ti-lfa-05*. The following figure shows a simple topology that illustrates the operation of the TI-LFA algorithm for node protection.

Figure 30: Application of the TI-LFA algorithm for node protection



In the figure, for each destination prefix D, R1 programs the TI-LFA repair tunnel (**max-sr-frr-labels=1**):

- For prefixes other than those owned by nodes R2 and R3, R1 programs a node-protect repair tunnel to the P-Q pair R3-R6 by pushing the SID of adjacency R3-R6 on top of the SID for destination D and programming a next hop of R3.
- For prefixes owned by node R2, R1 runs the link-protect TI-LFA algorithm and programs a simple link-protect repair tunnel that consists of a backup next hop of R3 and pushes no additional label on top of the SID for the destination prefix.
- Prefixes owned by node R3 are not impacted by the failure of R2 because their primary next hop is R3.

The topology computation for [Figure 30: Application of the TI-LFA algorithm for node protection](#) is as follows:

1. The algorithm computes the post-convergence SPF on the topology without the protected node.

R1 computes TI-LFA on the topology without the protected node R2 and finds a single post-convergence path to destination D via R3 and R6. Prefixes owned by all other nodes in the topology have a post-convergence path via R3 and R6 except for prefixes owned by node R2. The latter uses the link R3-R2 and they can only benefit from link protection.

2. The algorithm computes the extended P space of R1 with respect to protected node R2 on the post-convergence paths. This is the set of nodes  $Y_i$  in the post-convergence paths that are reachable from R1 neighbors, other than protected node R2, without any path transiting the protected node R2.

R1 computes an LFA SPF rooted at each of its neighbors within the post-convergence paths (for example, R3) using the following equation:

$$\text{Distance\_opt}(R3, Y_i) < \text{Distance\_opt}(R3, R2) + \text{Distance\_opt}(R2, Y_i)$$

where  $\text{Distance\_opt}(A,B)$  is the shortest distance between A and B

The extended P-space calculation yields node R3 only.

3. The algorithm computes the Q space of R1 with respect to protected link R1-R2 on the post-convergence paths. This is the set of nodes  $Z_i$  in the post-convergence paths from which node R2 can be reached without any path transiting the protected link R1-R2. The algorithm uses the following equation:

$$\text{Distance\_opt}(Z_i, R2) < \text{Distance\_opt}(Z_i, R1) + \text{Distance\_opt}(R1, R2)$$

The reverse SPF for the Q-space calculation is the same as in the link-protect algorithm and uses the protected node R2 as the proxy for all destination prefixes. If the Q space is computed with respect to the protected node R2 instead of link R1-R2, a reverse SPF would have to be done to each destination D, which is very costly and would not scale. However, computing the Q space with respect to link R1-R2 means that the algorithm only guarantees that the path from the computing node to the Q node is node-protecting. The path from the Q node to the destination D is not guaranteed to avoid the protected node R2. The intersection of the Q space with the post-convergence path is modified in the next step to mitigate this risk.

This step yields nodes R3, R4, R5, and R6.

4. For each post-convergence path, the algorithm searches for the closest Q node to destination D and selects the closest P node to this Q node, up to the number of labels corresponding to the value configured for the **ti-lfa max-sr-frr-labels** parameter.

This step yields the following P-Q sets depending on the configuration of **max-sr-frr-labels**:

- When **max-sr-frr-labels=0**, R3 is the closest Q node to the destination D and R3 is the only P node. This case is the one that results in link protection via PQ node R3.

- When **max-sr-frr-labels=1**, R6 is the closest Q node to the destination D and R3 is the only P node. The repair tunnel for this case uses the SID of the adjacency over link R3-R6 as shown in [Figure 30: Application of the TI-LFA algorithm for node protection](#).
- When **max-sr-frr-labels=2**, R5 is the closest Q node to the destination D and R3 is the only P node. The repair tunnel for this case uses the SIDs of the adjacencies over links R3-R6 and R6-R5.
- When **max-sr-frr-labels=3**, R4 is the closest Q node to the destination D and R3 is the only P node. The repair tunnel for this case uses the SIDs of the adjacencies over links R3-R6, R6-R5, and R5-R4.



**Note:** This step of the algorithm is modified from the link protection algorithm, which prefers Q nodes that are closest to the computing router R1. This modification minimizes the probability that the path from the Q node to the destination D goes via the protected node R2 as described in step 2. There is, however, still a possibility that the found P-Q set achieves link protection only.

5. The algorithm selects the P-Q set. If a candidate P-Q set is found on each of the multiple ECMP post-convergence paths in step 4, the following rules are applied in ascending order to select a single set:
  - a. lowest number of labels
  - b. lowest next-hop router ID
  - c. lowest interface index if the next-hop router ID is the same

If multiple parallel links with adjacency SIDs exist between the P and Q nodes of the selected P-Q set, the following rules are used to select one of the links:

- use the adjacency SID with the lowest metric
- use the adjacency SID with the lowest SID value if the lowest metric is the same

### 5.1.10.6.3 Remote LFA node-protect operation

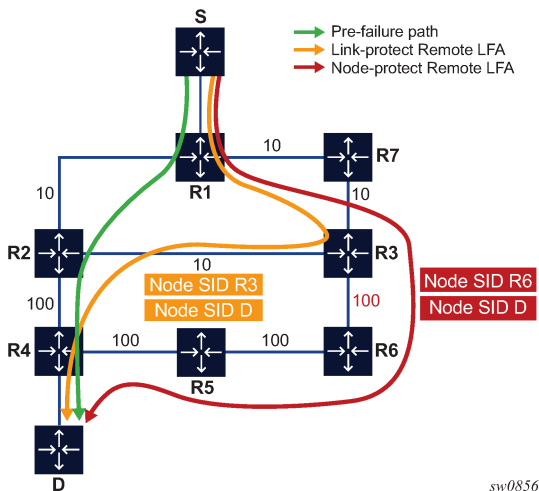
The 7705 SAR supports the node-protect extensions to the remote LFA algorithm as described in RFC 8102.

Remote LFA follows a similar algorithm to TI-LFA but does not limit the scope of the calculation of the extended P space and the Q space to the post-convergence paths.

Remote LFA adds an extra forward SPF on behalf of the PQ node, to ensure that for each destination the selected PQ node does not use a path via the protected node.

The following figure shows the application of the remote LFA algorithm for node protection with a slightly modified typology from that shown in [Figure 30: Application of the TI-LFA algorithm for node protection](#). A new node, R7, is added to the top ring and the metric for link R3-R6 is changed to 100.

Figure 31: Application of the remote LFA algorithm for node protection



When the algorithm for remote LFA for node protection is applied to the topology shown in the figure, it performs the following steps:

1. The algorithm computes the extended P space of R1 with respect to protected node R2.

This is the set of nodes  $Y_i$  that are reachable from R1 neighbors, other than protected node R2, without any path transiting the protected node R2.

R1 computes an LFA SPF rooted at each of its neighbors, in this case R7, using the following equation:

$$\text{Distance\_opt}(R7, Y_i) < \text{Distance\_opt}(R7, R2) + \text{Distance\_opt}(R2, Y_i)$$

where  $\text{Distance\_opt}(A,B)$  is the shortest distance between A and B

Nodes R7, R3, and R6 satisfy this inequality.

2. The algorithm computes the Q space of R1 with respect to protected link R1-R2.

This is the set of nodes  $Z_i$  from which node R2 can be reached without any path transiting the protected link R1-R2. The following equation is used:

$$\text{Distance\_opt}(Z_i, R2) < \text{Distance\_opt}(Z_i, R1) + \text{Distance\_opt}(R1, R2)$$

The reverse SPF for the Q-space calculation is the same as in the remote LFA link-protect algorithm and uses the protected node R2 as the proxy for all destination prefixes.

This step yields nodes R3, R4, R5, and R6.

Therefore, the candidate PQ nodes after this step are nodes R3 and R6.

3. For each PQ node found, the algorithm runs a forward SPF to each destination D.

This step is required to select only the subset of PQ nodes that do not traverse protected node R2.

$$\text{Distance\_opt}(PQ_i, D) < \text{Distance\_opt}(PQ_i, R2) + \text{Distance\_opt}(R2, D)$$

Of the candidate PQ nodes R3 and R6, only PQ node R6 satisfies this inequality.



**Note:** This step of the algorithm is applied to the subset of candidate PQ nodes from steps 1 and 2 to which the parameter **max-pq-cost** was already applied. This subset is further reduced in this step by retaining the candidate PQ nodes that provide the highest coverage

among all protected nodes in the topology while not exceeding the number of nodes set with the **max-pq-nodes** parameter.

If multiple candidate PQ nodes are yielded out of this step, the detailed selection rules of a single PQ node from the candidate list are described in step4.

4. The algorithm selects a PQ node.

If multiple PQ nodes satisfy the criteria in all the above steps, R1 further selects the PQ node as follows:

- a. R1 selects the lowest IGP cost from R1.
- b. If more than one PQ node remains, R1 selects the PQ node reachable via the neighbor with the lowest router ID (OSPF) or system ID (IS-IS).
- c. If more than one PQ remains, R1 selects the PQ node with the lowest router ID (OSPF) or system ID (IS-IS).

For each destination prefix D, R1 programs the remote LFA backup path as follows:

- For prefixes of R5 or R4 or downstream of R4, R1 programs a node-protect remote LFA repair tunnel to the PQ node R6 by pushing the SID of node R6 on top of the SID for destination D and programming a next hop of R7.
- For prefixes owned by node R2, R1 runs the link-protect remote LFA algorithm and programs a simple link-protect repair tunnel that consists of a backup next hop of R7 and pushes the SID of PQ node R3 on top of the SID for the destination prefix D.
- Prefixes owned by nodes R7, R3, and R6 are not impacted by the failure of R2 because their primary next hop is R7.

#### 5.1.10.6.4 TI-LFA and remote LFA node protection feature interactions and limitations

[LFA protection option applicability](#) describes the order of activation of the various LFA types on a per-prefix basis: TI-LFA, followed by base LFA, followed by remote LFA.

Node protection is enabled for TI-LFA and remote LFA separately. The base LFA prefers node protection over link protection.

The order of activation of the LFA types supersedes the protection type (node versus link). Consequently, a prefix may be programmed with a link-protect backup next hop by the more preferred LFA type. For example, a prefix could be programmed with the only link-protect backup next hop found by the base LFA while there exists a node-protect remote LFA next hop.

#### 5.1.10.7 IPv6 segment routing using MPLS encapsulation

This feature implements support for SR IPv6 tunnels in IS-IS MT 0. The user can configure a node SID for the primary IPv6 global address of a loopback interface, which then gets advertised in IS-IS. IS-IS automatically assigns and advertises an adjacency SID for each adjacency with an IPv6 neighbor. After the node SID is resolved, it is used to install an IPv6 SR-ISIS tunnel in the TTM for use by the services.

##### 5.1.10.7.1 IS-IS MT 0 extensions

The IS-IS MT 0 extensions consist of supporting the advertising and resolution of the prefix SID sub-TLV within the IP reachability TLV-236 (IPv6), which is defined in RFC 5308. The adjacency SID is

still advertised as a sub-TLV of the Extended IS Reachability TLV 22, as defined in RFC 5305, *IS-IS Extensions for Traffic Engineering*, as in the case of an IPv4 adjacency. The router sets the V-Flag and I-Flag in the SR-Capabilities sub-TLV to indicate that it is capable of processing SR MPLS-encapsulated IPv4 and IPv6 packets on its network interfaces.

### 5.1.10.7.2 Supported service and forwarding contexts

The service and forwarding contexts supported with SR-ISIS IPv6 tunnels are:

- SDP of type **sr-isis** with **far-end** option using IPv6 address
- VLL, VPLS, IES/VP RN spoke-SDP interfaces, r-VPLS
- PW redundancy within Epipe/Ipipe VLLs, Epipe spoke-SDP termination on VPLS and r-VPLS, and Epipe/Ipipe spoke-SDP termination on IES/VP RN
- remote mirroring

### 5.1.10.7.3 Services using SDP with an SR IPv6 tunnel

The MPLS SDP of type **sr-isis** with a **far-end** option using an IPv6 address is supported. The SDP must have the same IPv6 **far-end** address, used by the control plane for the T-LDP session, as the prefix of the node SID of the SR IPv6 tunnel.

#### Example:

```
configure
service
  [no] sdp sdp-id mpls
  [no] far-end ipv6-address
  sr-isis
  no sr-isis
```

The **bgp-tunnel**, **lsp**, **sr-te lsp**, **sr-ospf**, and **mixed-lsp-mode** commands are blocked within the SDP configuration context when the far-end address is an IPv6 address.

SDP admin groups are not supported with an SDP using an SR IPv6 tunnel, or with SR-OSPF for IPv6 tunnels, and their assignment is blocked in the CLI.

Services that use an LDP control plane such as T-LDP VPLS and r-VPLS, VLL, and IES/VP RN spoke-SDP interfaces have the spoke SDP (PW) signaled with an IPv6 T-LDP session because the **far-end** option is configured to an IPv6 address. The spoke SDP for these services binds to an SDP that uses an SR IPv6 tunnel where the prefix matches the **far-end** address. The 7705 SAR also supports the IPv6 PW control word with both data plane packets and VCCV OAM packets.

The PW switching feature is not supported with LDP IPv6 control planes. As a result, the CLI does not allow the user to enable the **vc-switching** option whenever one or both spoke SDPs uses an SDP that has the **far-end** configured as an IPv6 address.

Layer 2 services that use the BGP control plane, such as dynamic MS-PW, cannot bind to an SR IPv6 tunnel because a BGP session to a BGP IPv6 peer does not support advertising an IPv6 next hop for the Layer 2 NLRI. As a result, these services will not auto-generate SDPs using an SR IPv6 tunnel.

The shortest path bridging (SPB) feature works with spoke SDPs bound to an SDP that uses an SR IPv6 tunnel.

### 5.1.10.8 Data path support

A packet received with a label matching either a node SID or an adjacency SID is forwarded according to the ILM type and operation, as described in the following table.

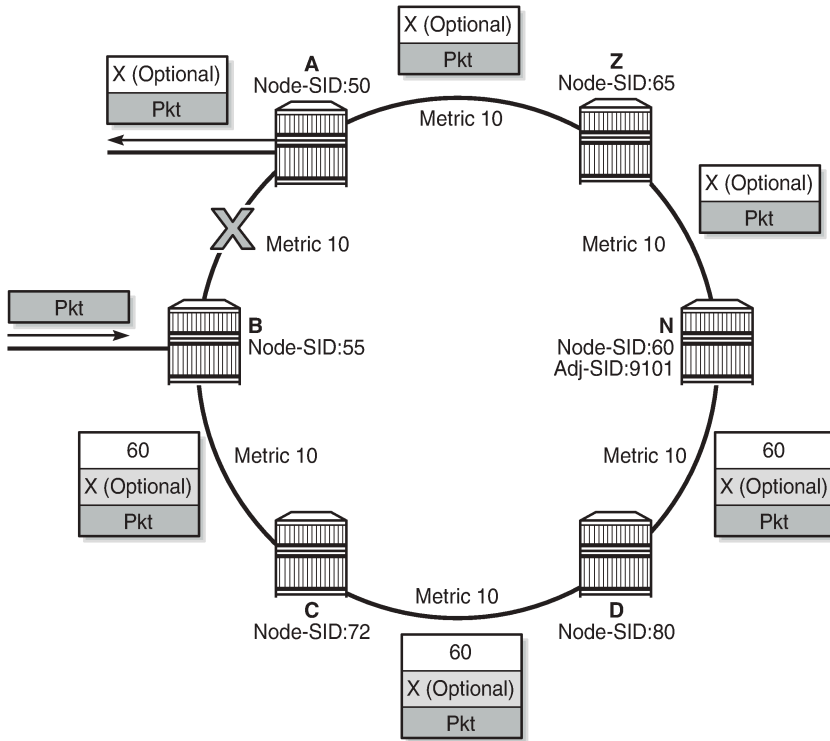
*Table 63: Data path support*

Label type	Operation
Top label is a local node SID	Label is popped and the packet is further processed If the popped node SID label is the bottom of stack label, the IP packet is looked up and forwarded in the appropriate FIB
Top or next label is a remote node SID	Label is swapped to the calculated label value for the next hop and forwarded according to the primary or backup NHLFE With ECMP, a maximum of 8 primary next hops (NHLFEs+) are programmed for the same destination prefix and for each IGP instance. ECMP and LFA next hops are mutually exclusive
Top or next label is an adjacency SID	Label is popped and the packet is forwarded out on the interface to the next hop associated with this adjacency SID label In effect, the data path operation is modeled like a swap to an implicit-null label instead of a pop
Next label is a BGP 3107 label	The packet is further processed according to the ILM operation in the current implementation: <ul style="list-style-type: none"> <li>the BGP label may be popped and the packet looked up in the appropriate FIB</li> <li>the BGP label may be swapped to another BGP label</li> </ul>
Next label is a service label	The packet is looked up and forwarded in the Layer 2 or VPRN FIB

A router forwarding an IP or a service packet over an SR tunnel pushes a maximum of two transport labels with a remote LFA next hop. This is illustrated in the following figure.



Figure 32: Transport label stack in shortest path forwarding with segment routing



27870

In the figure, a VPRN service in node B forwards a packet received on a SAP to a destination VPN-IPv4 prefix X advertised by a remote PE2 via ASBR/ABR node A. Router B is in a segment routing domain while PE2 is in an LDP domain. BGP label routes are used to distribute the PE /32 loopbacks between the two domains.

When node B forwards a packet over the primary next hop for prefix X, it pushes the node SID of the ASBR followed by the BGP 3107 label for PE2, followed by the service label for prefix X. When the remote LFA next hop is activated, node B pushes one or more segment routing labels: the node SID for the remote LFA backup node (node N).

When node N receives the packet while the remote LFA next hop is activated, it pops the top segment routing label, which corresponds to a local node SID. The packet is then forwarded to the ASBR node over the shortest path (link N-Z).

When the ASBR/ABR node receives the packet from either node B or node Z, it pops the segment routing label that corresponds to a local node SID, then swaps the BGP label and pushes the LDP label of PE2, which is the next hop of the BGP label route.

### 5.1.10.9 Control protocol changes

This section describes both [IS-IS control protocol changes](#) and [OSPF control protocol changes](#).

### 5.1.10.9.1 IS-IS control protocol changes

New TLV/sub-TLVs are defined in *draft-ietf-isis-segment-routing-extensions* and are supported in the implementation of segment routing in IS-IS:

- the prefix SID sub-TLV
- the adjacency SID sub-TLV
- the SID/Label Binding TLV
- SR-Capabilities sub-TLV
- SR-Algorithm sub-TLV

This section describes the behaviors and limitations of IS-IS support of segment routing TLV and sub-TLVs.

The 7705 SAR supports advertising the IS-IS router capability TLV (RFC 4971) only for topology MT 0. As a result, the segment routing capability sub-TLV can only be advertised in MT 0, which restricts the segment routing feature to MT 0.

Similarly, if prefix SID sub-TLVs for the same prefix are received in different MT numbers of the same IS-IS instance, only the one in MT 0 is resolved. If the prefix SID index is also duplicated, an error is logged and a trap is generated, as described in [Error and resource exhaustion handling](#).

The I and V flags are both set to 1 when originating the SR capability sub-TLV to indicate support for processing both SR MPLS-encapsulated IPv4 and IPv6 packets on its network interfaces. These flags are not checked when the sub-TLV is received. Only the SRGB range is processed.

Both IPv4 and IPv6 prefix and adjacency SID sub-TLVs originate within MT 0.

The 7705 SAR originates a single prefix SID sub-TLV per IS-IS IP reachability TLV and processes the first prefix SID sub-TLV only if multiple SID sub-TLVs are received within the same IS-IS IP reachability TLV.

The 7705 SAR encodes the 32-bit index in the prefix SID sub-TLV. The 24-bit label is not supported.

The 7705 SAR originates a prefix SID sub-TLV with the following encoding of the flags and the following processing rules:

- The R-flag is set if the prefix SID sub-TLV, along with its corresponding IP reachability TLV, is propagated between levels. See below for more details about prefix propagation.
- The N-flag is always set because the 7705 SAR supports prefix SID of type node SID only.
- The P-flag (no-PHP flag) is always set, meaning that the label for the prefix SID is pushed by the PHP router when forwarding to this router. The 7705 SAR PHP router properly processes a received prefix SID with the P-flag set to zero and uses implicit-null for the outgoing label toward the router that advertised it as long as the P-flag is also set to 1.
- The E-flag (Explicit-Null flag) is always set to 0. A 7705 SAR PHP router, however, properly processes a received prefix SID with the E-flag set to 1, and when the P-flag is also set to 1, it pushes explicit-null for the outgoing label toward the router that advertised it.
- The V-flag is always set to 0 to indicate an index value for the SID.
- The L-flag is always set to 0 to indicate that the SID index value is not locally significant.
- A router that receives the TLV advertisement leaks it between IS-IS levels 1 and 2. If leaked from level 2 to level 1, the D-flag must be set; this prevents the TLV from being leaked back into level 2.
- The A-flag is used to indicate that a prefix for which the mapping server prefix SID is advertised is directly attached.

- The M-flag is used to advertise a SID for a mirroring context to provide protection against the failure of a service node.
- The algorithm field is set to 0 to indicate that the shortest path first (SPF) algorithm based on link is used when originating the SR-Algorithm capability sub-TLV but is not checked when the sub-TLV is received.
- The 7705 SAR still resolves a prefix SID sub-TLV received without the N-flag set but with the prefix length equal to 32. However, a trap is raised by IS-IS.
- The 7705 SAR will not resolve a prefix SID sub-TLV received with the N-flag set and a prefix length not equal to 32. A trap is raised by IS-IS.
- The 7705 SAR resolves a prefix SID received within a IP reachability TLV based on the following route preference:
  - a SID received via level 1 in a prefix SID sub-TLV part of IP reachability TLV
  - a SID received via level 2 in a prefix SID sub-TLV part of IP reachability TLV
- A prefix received in an IP reachability TLV is propagated, along with the prefix SID sub-TLV, by default from level 1 to level 2 by a level 1/2 router. A router in level 2 sets up an SR tunnel to the level 1 router via the level 1/2 router, which acts as an LSR.
- A prefix received in an IP reachability TLV is not propagated, along with the prefix SID sub-TLV, by default from level 2 to level 1 by a level 1/2 router. If the user adds a policy to propagate the received prefix, a router in L1 sets up an SR tunnel to the level 2 router via the level1/2 router, which acts as an LSR.
- If a prefix is summarized by an ABR, the prefix SID sub-TLV is not propagated with the summarized route between levels. To propagate the node SID for a /32 prefix, route summarization must be disabled.
- The 7705 SAR propagates the prefix SID sub-TLV when exporting the prefix to another IS-IS instance; however, it does not propagate it if the prefix is exported from a different protocol. Therefore, when the corresponding prefix is redistributed from another protocol such as OSPF, the prefix SID is removed.

The 7705 SAR originates an adjacency SID sub-TLV with the following encoding of the flags:

- the F-flag is set to 0 to indicate the IPv4 family and is set to 1 to indicate an IPv6 family for the adjacency encapsulation
- the B-flag is set to 0 and is not processed on receipt
- the V-flag is always set to 1
- the L-flag is always set to 1
- the S-flag is set to 0 because assigning an adjacency SID to parallel links between neighbors is not supported. A received adjacency SID with the S-flag set is not processed.
- the weight octet is not supported and is set to all 0s.

The 7705 SAR can originate the SID/Label Binding TLV as part of the mapping server feature functionality (see [Segment routing mapping server for IPv4 /32 prefixes \(IS-IS\)](#) for more information) and can also process the TLV if received. The following behavior applies:

- Only the mapping server prefix SID sub-TLV within the TLV is processed. The ILMs are installed if the prefixes in the provided range are resolved.
- If the same prefix is advertised with both a prefix SID sub-TLV and a mapping server Prefix SID sub-TLV, the resolution follows the following route preference:
  - a SID received via level 1 in a prefix SID sub-TLV that is part of an IP reachability TLV

- a SID received via level 2 in a prefix SID sub-TLV that is part of an IP reachability TLV
- a SID received via level 1 in a mapping server prefix SID sub-TLV
- a SID received via level 2 in a mapping server prefix SID sub-TLV
- The range and FEC prefix fields are processed. Each FEC prefix is resolved in the same way as the prefix SID sub-TLV; that is, there must be an IP reachability TLV received for the exact matching prefix in order for it to be resolved.
- The entire TLV can be propagated between levels based on the settings of the S-flag. The TLV cannot be propagated between IS-IS instances (see [Segment routing mapping server for IPv4 /32 prefixes \(IS-IS\)](#) for more information).

A level 1/2 router is not propagated with the prefix SID sub-TLV from the SID/Label Binding TLV, which is received from a mapping server, into the IP reachability TLV if the SID/Label Binding TLV is propagated between levels.

- The mapping server that advertises the SID/Label Binding TLV does not need to be in the shortest path for the FEC prefix.
- If the same FEC prefix is advertised in multiple binding TLVs by different routers, the SID in the binding TLV of the first reachable router is used. If that router becomes unreachable, the next reachable one is used.
- No check is performed to determine whether the contents of the binding TLVs from different mapping servers are consistent.
- Any other sub-TLV, such as the ERO metric or unnumbered interface ID ERO SID/Label sub-TLV, is ignored. However, a user can get an output of the octets of the received but unsupported sub-TLVs by using the IGP **show** command.

### 5.1.10.9.2 OSPF control protocol changes

New TLV/sub-TLVs are defined in *draft-ietf-ospf-segment-routing-extensions-04* and are required for the implementation of segment routing in OSPF:

- the prefix SID sub-TLV part of the OSPFv2 Extended Prefix TLV
- the prefix SID sub-TLV part of the OSPFv2 Extended Prefix Range TLV
- the adjacency SID sub-TLV part of the OSPFv2 Extended Link TLV
- SID/Label Range Capability TLV
- SR-Algorithm Capability TLV

This section describes the behaviors and limitations of OSPF support of segment routing TLV and sub-TLVs.

The 7705 SAR originates a single prefix SID sub-TLV per OSPFv2 Extended Prefix TLV and processes the first one only if multiple prefix SID sub-TLVs are received within the same OSPFv2 Extended Prefix TLV.

The 7705 SAR encodes the 32-bit index in the prefix SID sub-TLV. The 24-bit label or variable IPv6 SID is not supported.

The 7705 SAR originates a prefix SID sub-TLV with the following encoding of the flags:

- The NP-flag is always set, meaning that the label for the prefix SID is pushed by the PHP router when forwarding to this router. The 7705 SAR PHP router properly processes a received prefix SID with the NP-flag set to 0 and uses implicit-null for the outgoing label toward the router that advertised it.

- The M-flag is never set because the 7705 SAR does not support originating a mapping server prefix SID sub-TLV.
- The E-flag is always set to 0. The 7705 SAR PHP router properly processes a received prefix SID with the E-flag set to 1, and when the NP-flag is also set to 1, it pushes explicit-null for the outgoing label toward the router that advertised it.
- The V-flag is always set to 0 to indicate an index value for the SID.
- The L-flag is always set to 0 to indicate that the SID index value is not locally significant.
- The algorithm field is always set to 0 to indicate that the shortest path first (SPF) algorithm based on link metric is used and is not checked on a received prefix SID sub-TLV.

The 7705 SAR resolves a prefix SID received within an Extended Prefix TLV based on the following route preference:

- SID received via an intra-area route in a prefix SID sub-TLV part of Extended Prefix TLV
- SID received via an inter-area route in a prefix SID sub-TLV part of Extended Prefix TLV

The 7705 SAR originates an adjacency SID sub-TLV with the following encoding of the flags:

- The F-flag is not set to indicate that the Adjacency SID refers to an adjacency with outgoing IPv4 encapsulation.
- The B-flag is set to 0 and is not processed on receipt.
- The V-flag is always set.
- The L-flag is always set.
- The S-flag is not supported.
- The weight octet is not supported and is set to all 0s.

The 7705 SAR does not originate the OSPFv2 Extended Prefix Range TLV but can process it properly if received. The following rules and limitations should be considered:

- Only the prefix SID sub-TLV within the TLV is processed and the ILMs installed if the prefixes are resolved.
- The range and address prefix fields are processed. Each prefix is resolved separately.
- Any other sub-TLV, for example, the ERO metric and unnumbered interface ID ERO, is ignored, but the user can get a list of the octets of the received but not supported sub-TLVs using the existing IGP **show** command.

The 7705 SAR supports propagation on the ABR of external prefix LSAs into other areas with the route type set to 3 as per *draft-ietf-ospf-segment-routing-extensions-04*.

The 7705 SAR supports propagation on the ABR of external prefix LSAs with route type 7 from an NSSA area into other areas with route type set to 5 as per *draft-ietf-ospf-segment-routing-extensions-04*. The 7705 SAR does not support propagation of the prefix SID sub-TLV in OSPF.

When the user configures an OSPF import policy, the outcome of the policy applies to prefixes resolved in the RTM and the corresponding tunnels in the TTM. A prefix removed by the policy will not appear as both a route in the RTM and as an SR tunnel in the TTM.

### 5.1.10.10 BGP label route resolution using segment routing tunnel

The resolution of RFC 3107 BGP label route prefixes using SR tunnels to BGP next hops in the TTM is enabled with the following command:

#### CLI syntax:

```
configure>router>bgp>next-hop-resolution
  label-routes-transport-tunnel
    [no] family {vpn | label-ipv4}
      resolution {any | filter | disabled}
      resolution-filter
        [no] ldp
        [no] rsvp
        [no] sr-isis
        [no] sr-ospf
        [no] sr-te
      exit
    exit
  exit
```

If the **resolution** option is explicitly set to **disabled**, the default binding to LDP tunnels resumes. If **resolution** is set to **any**, any supported tunnel type in the BGP label route context is selected following the TTM preference. If **resolution** is set to **filter**, the **resolution-filter** option is used.

The following tunnel types are supported in a BGP label route context and in order of preference: RSVP, SR-TE, LDP, SR-OSPF, and SR-ISIS.

If the **sr-isis** or **sr-ospf** option is specified using the **resolution-filter** option, a tunnel to the BGP next hop is selected in the TTM from the lowest-numbered IS-IS instance or from OSPF.

See the [BGP](#) chapter for more details.

### 5.1.10.11 Service packet forwarding with segment routing

SDP subtypes of the MPLS type are available to allow service binding to an SR tunnel programmed in the TTM by OSPF or IS-IS:

#### CLI syntax:

```
configure>service>sdp sdp-id mpls create
  sr-ospf
  sr-isis
```

The SDP of type **sr-isis** or **sr-ospf** can be used with the **far-end** option. When the **sr-isis** or **sr-ospf** option is enabled, a tunnel to the far-end address is selected in the TTM from the lowest-preference IS-IS instance or from OSPF. If multiple instances have the same lowest preference, the lowest-numbered IS-IS instance is selected. The SR-ISIS or SR-OSPF tunnel is selected at the time of the binding, following the tunnel selection rules. If a more preferred tunnel is subsequently added to the TTM, the SDP will not automatically switch to the new tunnel until the next time the SDP is being resolved.

The signaling protocol for the service labels for an SDP using an SR tunnel can be configured to static (**off**) or T-LDP (**tldp**), or BGP (**bgp**).

SR tunnels can be used in VPRN services and BGP EVPN with the **auto-bind-tunnel** command. See [Next-hop resolution of BGP labeled routes to tunnels](#) for more information.

Both VPN-IPv4 and VPN-IPv6 (6VPE) are supported in a VPRN service or BGP EVPN using segment routing transport tunnels with the **auto-bind-tunnel** command.

For more information about the VPRN **auto-bind-tunnel** command, see the 7705 SAR Services Guide, "VPRN auto-binding tunnels".

The following are the service contexts that are supported with SR tunnels:

- VLL, LDP VPLS, IES/VPRN spoke-SDP interfaces, and r-VPLS
- Intra-AS BGP VPRN for VPN-IPv4 and VPN-IPv6 prefixes with both autobind and explicit SDP

The following service contexts are not supported:

- inter-AS VPRN
- dynamic MS-PW, PW-switching

### 5.1.10.12 Segment routing mapping server for IPv4 /32 prefixes (IS-IS)

The mapping server feature allows the configuration and advertisement via IS-IS of the node SID index for prefixes of routers which are in the LDP domain. This functionality is performed in the router acting as a mapping server and using a prefix SID sub-TLV within the SID/Label Binding TLV in IS-IS.

For more information about prefix SID sub-TLVs and SID/Label Binding TLVs, as well as information on the setting of the various types of flags associated with IS-IS support of SR TLV and sub-TLVs, see [IS-IS control protocol changes](#). For more information about LDP-to-SR stitching, see the 7705 SAR MPLS Guide, "LDP-to-Segment Routing Stitching for IPv4 /32 Prefixes (IS-IS)".

An SR mapping server is configured using the following CLI commands:

#### CLI syntax:

```
configure
router
isis
    segment-routing
        mapping-server
            sid-map node-sid {index value [range value]} prefix
                {ip-address/mask | ip-address netmask} [set-flags {s}] [level {1|2|1/2}]
```

A user can enter the **node-sid** index for one prefix or a range of prefixes by specifying the index value or a value range. Only the first prefix in a consecutive range of prefixes must be entered. If the user enters the first prefix with a mask lower than 32, the SID/Label Binding TLV is advertised but the router does not resolve the prefix SIDs; a trap is originated instead.

The user can configure the S-flag using the **set-flags** option to indicate to the IS-IS network routers that the flooding of the SID/Label Binding TLV applies to the entire domain. A router that receives the TLV advertisement leaks it between IS-IS levels 1 and 2. If leaked from level 2 to level 1, the D-flag must be set; this prevents the TLV from being leaked back into level 2. The S-flag is not defined by default; if it is not configured, the TLV is not leaked by routers receiving the mapping server advertisement.

The user can specify the mapping server's flooding scope for the generated SID/Label Binding TLV using the **level** option. The default flooding scope of the mapping server is level 1/2.



**Note:** The 7705 SAR does not leak the SID/Label Binding TLV between IS-IS instances.

Each time a prefix or a range of prefixes is configured in the SR mapping database in any routing instance, the router issues a prefix SID sub-TLV within an IS-IS SID/Label Binding TLV for the prefix or range of



prefixes. The flooding scope of the TLV from the mapping server is determined as described above. No further check of the reachability of that prefix in the mapping server route table is performed, and no check is done to determine if the SID index is a duplicate of an existing prefix in the local IGP instance database or if the SID index is out of range with the local SRGB.

An SR-capable router, including the mapping server and its clients, attempts to resolve each received prefix SID to either an SR tunnel endpoint or an LDP tunnel endpoint. See [Prefix SID resolution for a segment routing mapping server](#).

### 5.1.10.13 Mirror services

A spoke SDP can be bound to an SR tunnel to forward mirrored packets from a mirror source to a remote mirror destination. In the configuration of the mirror destination service at the destination node, the **remote-source** command must use a spoke SDP with a VC-ID that matches the one configured in the mirror destination service at the mirror source node. The far-end option is not supported with an SR tunnel.

Configuration at mirror source node:

#### CLI syntax:

```
config mirror mirror-dest 10
  no spoke-sdp sdp-id:vc-id
  spoke-sdp sdp-id:vc-id [create]
  egress
    vc-label egress-vc-label
```



#### Note:

- The *sdp-id* matches an SDP that uses an SR tunnel.
- For *vc-label*, both static and T-LDP egress VC labels are supported.

Configuration at mirror destination node:

#### CLI syntax:

```
configure mirror mirror-dest 10 remote-source
  spoke-sdp sdp-id:vc-id create <--- vc-id matching that of spoke-sdp
  configured in mirror destination context at mirror source node
  ingress
    vc-label ingress-vc-label
  exit
  no shutdown
  exit
exit
```



#### Note:

- The **far-end** command is not supported with an SR tunnel at the mirror destination node; the user must reference a spoke SDP using a segment routing SDP coming from the mirror source node:
  - **far-end** *ip-address* [*vc-id vc-id*] [*ing-svc-label ingress-vc-label* | *tldp*] [*icb*]
  - **no far-end** *ip-address*
- For *vc-label*, both static and T-LDP ingress VC labels are supported.

Mirroring is also supported with the PW redundancy feature when the endpoint spoke SDP, including the ICB, is using an SR tunnel.



### 5.1.11 Multi-instance IS-IS (MI-IS-IS)

The 7705 SAR routers support multiple IS-IS instances. There is one default (base) instance. The remaining (non-default) instances must be specified with an *isis-instance* value.

The default (base) and non-default MI-IS-IS instances use the following MAC addresses:

- default instance, as per the ISO 10589 standard:
  - 01-80-C2-00-00-14 for all level 1 routers (A1L1IS)
  - 01-80-C2-00-00-15 for all level 2 routers (A1L2IS)
- non-default instances, as per the RFC 6822 standard:
  - 01-00-5E-90-00-02 for all level 1 routers (A1L1MI-ISs)
  - 01-00-5E-90-00-03 for all level 2 routers (A1L2MI-ISs)



**Note:** On the 7705 SAR, all non-default instances use the same MAC address for routers at the same level, which is different multicast MAC address from the base instance. The non-default MAC address is not user-configurable and is permanently set.

All IS-IS instances on a 7705 SAR populate the same router information base (RIB).

To use the same router interface in more than one IS-IS instance, use the **iid-tlv-enable** command. When the **iid-tlv-enable** command is issued, the instance ID (IID) is included in all IS-IS PDUs so that the far-end router knows which instance will receive the packet.

### 5.1.12 IPv6 support

IS-IS for IPv6 routing supports two modes: single topology (native) and multitopology. For information about multitopology, see [Multitopology IS-IS](#). In native mode, IPv6 routing information is exchanged in IS-IS using the following TLVs contained in the LSP:

- IPv6 reachability TLV
- IPv6 interface address TLV

For detailed information, see RFC 5308, *Routing IPv6 with IS-IS*.

IPv4 and IPv6 routing can be run at the same time in an area. However, because one SPF calculation is performed per level to compute the routes, the IPv4 and IPv6 topologies must be the same. That is, both IPv4 and IPv6 addresses must be configured on all router interfaces in an area; otherwise, traffic may be blackholed. For example, if the SPF calculation includes a link that is not configured with an IPv6 address, IPv6 traffic will be blackholed over that link.

## 5.2 Bidirectional forwarding detection (BFD) for IS-IS

BFD is a simple protocol for detecting failures in a network. BFD uses a "hello" mechanism that sends control messages periodically to the far end and receives periodic control messages from the far end. BFD can detect device, link, and protocol failures.

When BFD is enabled on an IS-IS interface, the state of the interface is tied to the state of the BFD session between the local node and remote (far-end) node. BFD is implemented in asynchronous mode only

(similar to a heartbeat message), meaning that neither end responds to control messages; rather, the messages are sent in the interval configured at each end.

If the configured number of consecutive BFD missed messages is reached, the link is declared down and IS-IS takes the appropriate action (for example, generates a link-state PDU (LSP) against the failed link or reroutes around the failed link).

Due to the lightweight nature of BFD, the frequency of BFD packets can be relatively high (up to 10 per second); therefore, it can detect failures faster than other detection protocols, making it ideal for use in applications such as mobile transport.

## 5.3 LDP and IP fast reroute (FRR) for IS-IS prefixes

LDP fast reroute (FRR) provides local protection for an LDP FEC by precalculating and downloading a primary and a backup NHLFE for the FEC to the LDP FIB. The primary NHLFE corresponds to the label of the FEC received from the primary next hop as per the standard LDP resolution of the FEC prefix in the RTM. The backup NHLFE corresponds to the label received for the same FEC from a loop-free alternate (LFA) next hop.

LDP FRR improves convergence in case of a local link or node failure in the network, by using the label-FEC binding received from the LFA next hop to forward traffic for a given prefix as soon as the primary next hop is not available. This means that a router resumes forwarding LDP packets to a destination prefix using the backup path without waiting for the routing convergence.

IP fast reroute (FRR) protects against link or node failures in an IP network by precalculating a backup route to use when the primary next hop is not available. Both routes are populated in the RTM. IP FRR uses an LFA backup next hop to forward in-transit and CSM-generated IP packets as soon as the primary next-hop failure is detected and the backup is invoked. This means that a node resumes forwarding IP packets to a destination prefix without waiting for the routing convergence.

See RFC 5286, *Basic Specification for IP Fast Reroute: Loop-Free Alternates*, for more information about LFAs.

See the 7705 SAR MPLS Guide "LDP Fast Reroute (FRR)" for more information about LDP FRR and the 7705 SAR Router Configuration Guide, "IP Fast Reroute (FRR)" for more information about IP FRR.

LFAs are supported on IPv4 IS-IS prefixes and on inter-level IS-IS prefixes. LFAs are also supported on IPv4 and IPv6 OSPF prefixes, VPN IPv4 OSPF prefixes, and on inter-area OSPF prefixes. For information about LFA support for OSPF prefixes, see [LDP and IP fast reroute \(FRR\) for OSPF prefixes](#).

IP FRR also provides an LFA backup next hop for the destination prefix of a GRE tunnel used in an SDP or in VPRN autobind.

### 5.3.1 LFA calculations

In addition to performing the shortest path first (SPF) calculation of the primary next hop, IS-IS must calculate a backup next hop for all prefixes used by LDP to resolve FECs and for all prefixes used by IP to forward packets. The backup next hops are calculated to provide single link or node protection and to guarantee that when a failure occurs, forwarding traffic through the backup next hop will not result in a loop. These backup next hops are called Loop-Free Alternates (LFAs).

In general, in order to calculate LFAs for a specific destination (D), a router must know the following information:

- the shortest-path distance from the calculating router (source) to the destination (SP(S,D))
- the shortest-path distance from the router’s IS-IS neighbors to the destination (SP(N,D))
- the shortest-path distance from the router’s IS-IS neighbors to itself (SP(N,S))

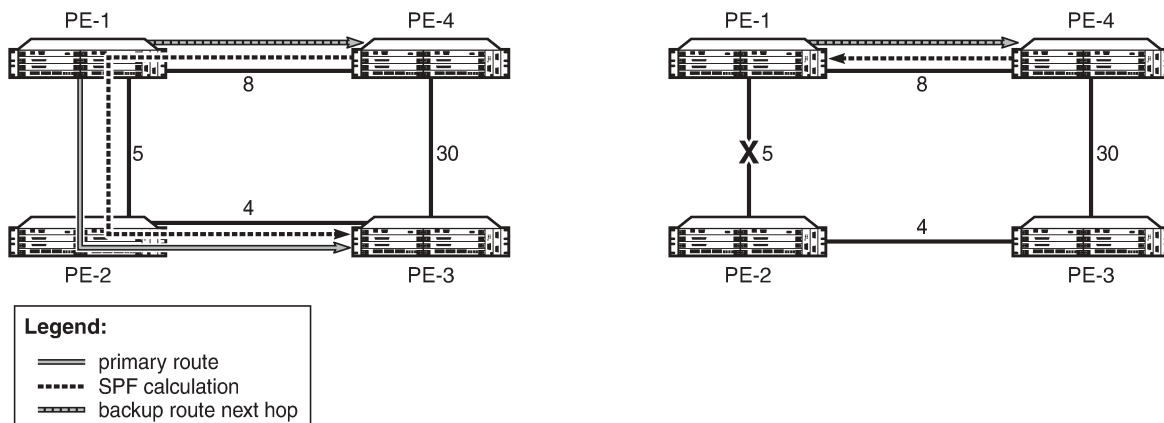
A neighbor (N) can provide an LFA only if:

$$SP(N,D) < SP(N,S) + SP(S,D)$$

This is known as loop-free criterion.

The following figure shows an example of a backup route resulting in a microloop. In the example, PE-1 uses PE-2 as its next hop to reach PE-3. The total cost to reach PE-3 via PE-2 is 9. If the link between PE-1 and PE-2 fails, PE-1 can try to use PE-4 as its next hop to reach PE-3. However, the metric between PE-4 and PE-3 is 30. From the perspective of PE-4, forwarding traffic via the PE-1 and PE-2 path to PE-3 is more viable, as the cost is 17 (8 + 5 + 4) versus the direct link cost of 30. Therefore, if PE-1 forwards the traffic to PE-4 in order to reach PE-3, PE-4 forwards it back to PE-1, creating a microloop, until the routing protocols converge and declare the link between PE-1 and PE-2 to be down. PE-4 would then be forced to take the direct PE-3 link to reach PE-3 as there is no other alternative. Because PE-4 does not meet the loop-free criterion, it cannot be used as a valid LFA.

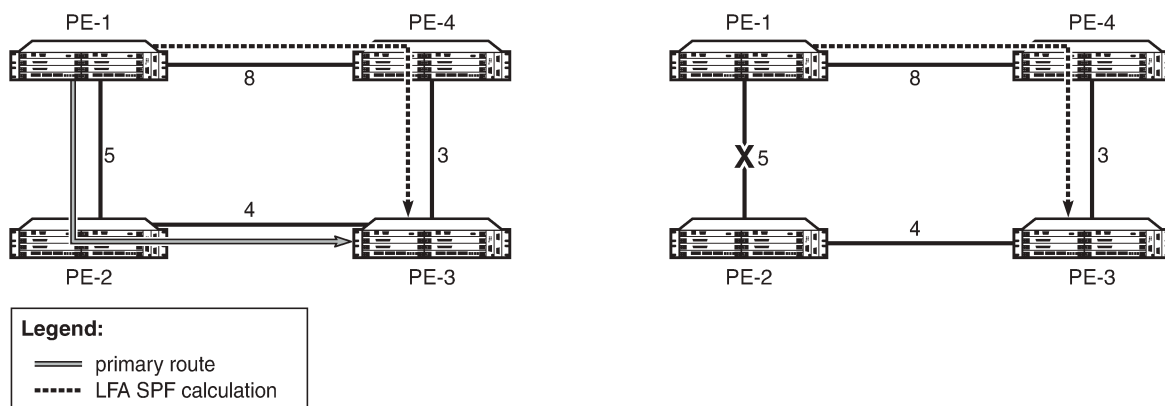
Figure 33: Backup routes resulting in microloops



25313

The following figure shows an example of an LFA backup route. In this example, PE-1 again uses PE-2 as its next hop to reach PE-3. The total cost to reach PE-3 via PE-2 is 9. If the link between PE-1 and PE-2 fails, PE-1 can use PE-4 to reach PE-3. From the perspective of PE-4, the direct route to PE-3 is a viable route, as the cost is 3 versus the cost of forwarding traffic via PE-1 (17). Using the direct route does not cause microloops and meets the loop-free criterion; therefore, PE-4 can be used as a valid LFA.

Figure 34: LFA backup route



25314

### 5.3.1.1 Selection algorithm

For a point-to-point interface, if SPF finds multiple LFA next hops for a given primary next hop, the selection algorithm is as follows:

1. SPF will pick the node-protect type over the link-protect type.
2. If there is more than one LFA next hop within the selected type, it will pick one based on the least cost.
3. If there is more than one LFA next hop with the same cost, SPF will select the first one. This is not a deterministic selection and will vary for each SPF calculation.

For a broadcast interface, a node-protect LFA is not necessarily a link-protect LFA if the path to the LFA next hop goes over the same pseudonode as the primary next hop. Similarly, a link-protect LFA may not guarantee link protection if it goes over the same pseudonode as the primary next hop.

When SPF finds multiple LFA next hops for a given primary next hop, the selection algorithm is as follows:

1. The algorithm splits the LFA next hops into two sets:
  - the first set consists of LFA next hops that do not go over the pseudonode used by the primary next hop
  - the second set consists of LFA next hops that do go over the pseudonode used by the primary next hop
2. If there is more than one LFA next hop in the first set, it will pick the node-protect type over the link-protect type.
3. If there is more than one LFA next hop within the selected type, it will pick one based on the least cost.
4. If there is more than one LFA next hop with the same cost, SPF will select the first one from the remaining set. This is not a deterministic selection and will vary for each SPF calculation.
5. If no LFA next hop results from step 4, SPF will rerun steps 2 to 4 using the second set.



**Note:** A node-protect LFA that does not guarantee link protection can still be selected as a last resort; as well, a link-protect LFA that does not guarantee node protection can still be selected as a last resort.

Both the calculated primary next hop and LFA next hop for a particular prefix are programmed into the RTM.

### 5.3.1.2 LFA configuration

To enable LFA for IS-IS prefixes, enter the following command at the IS-IS instance level:

```
config>router>isis>loopfree-alternates
```

Next, enable FRR for LDP or IP by entering the following commands:

```
config>router>ldp>fast-reroute
```

```
config>router>ip-fast-reroute
```

These commands instruct the IS-IS SPF algorithm to precalculate a primary next hop and LFA next hop for every learned prefix in order to provide FRR to LDP FEC packets or IP packets.

To exclude all interfaces within a specific IS-IS level or to exclude a specific IP interface from being included in the LFA SPF calculation, enter the following commands:

```
config>router>isis>level>loopfree-alternate-exclude
```

```
config>router>isis>interface>loopfree-alternate-exclude
```

If IGP shortcuts are also enabled, any LSPs with a destination address in that IS-IS level are not included in the LFA SPF calculation.

If an interface is excluded from the LFA SPF in IS-IS, it is excluded in both level 1 and level 2.

### 5.3.2 IGP shortcuts (RSVP-TE tunnels)

Microloops, especially in ring topologies, are typically unavoidable. As the number of nodes in a ring increases, the chance of microloops occurring also increases. In cases where a valid directly connected next hop cannot be ensured, remote LFAs can be used. Remote LFAs are non-directly connected LFA next hops that are reached via IGP shortcuts.

IGP shortcuts are an MPLS functionality where LSPs are treated like physical links within IGPs; that is, LSPs can be used for next-hop reachability. If an RSVP-TE LSP is used as a shortcut by OSPF or IS-IS, it is included in the SPF calculation as a point-to-point link for both primary and LFA next hops. It can also be advertised to neighbors so that the neighboring nodes can also use the links to reach a destination via the advertised next hop.

IGP shortcuts can be used to simplify remote LFA support and simplify the number of LSPs required in a ring topology.

IGP shortcut functionality provides two options:

- **LFA-protect** option

This option allows an LSP to be included in both the main SPF and the loop-free alternate (LFA) SPF algorithm. For a specific prefix, the LSP can be used either as a primary next hop or as an LFA next hop, but not both. If the main SPF calculation selects a tunneled primary next hop for a prefix, the LFA SPF calculation will not select an LFA next hop for this prefix and the protection of this prefix will rely on the RSVP LSP FRR protection.

If the main SPF calculation selects a direct primary next hop, the LFA SPF calculation will select an LFA next hop for this prefix but will prefer a direct LFA next hop over a tunneled LFA next hop.

- **LFA-only** option

This option allows an LSP to be included in the LFA SPF algorithm only, which means that the introduction of IGP shortcuts does not affect the main SPF decision. For a specific prefix, the main SPF calculation always selects a direct primary next hop. The LFA SPF calculation will select an LFA next hop for this prefix but will prefer a direct LFA next hop over a tunneled LFA next hop.

### 5.3.2.1 Selection algorithm

If there are multiple LFA next hops for a primary next hop, the selection algorithm is as follows:

1. The algorithm splits the LFA next hops into two sets:
  - the first set consists of direct LFA next hops
  - the second set consists of tunneled LFA next hops after excluding the LSPs that use the same outgoing interface as the primary next hop
2. The algorithm continues with the first set if it is not empty; otherwise, it continues with the second set.
3. If the second set is used, the algorithm selects the tunneled LFA next hop whose endpoint corresponds to the node advertising the prefix:
  - if more than one tunneled next hop exists, it selects the one with the lowest LSP metric
  - if more than one tunneled next hop still exists, it selects the one with the lowest tunnel ID
  - if none is available, it continues with rest of the tunneled LFAs in the second set
4. Within the selected set, the algorithm splits the LFA next hops into two sets:
  - the first set consists of LFA next hops that do not go over the pseudonode used by the primary next hop
  - the second set consists of LFA next hops that go over the pseudonode used by the primary next hop
5. If there is more than one LFA next hop in the selected set, it will pick the node-protect type over the link-protect type.
6. If there is more than one LFA next hop within the selected type, it will pick one based on the least total cost for the prefix. For a tunneled next hop, that means the LSP metric plus the cost of the LSP endpoint to the destination of the prefix.
7. If there is more than one LFA next hop within the selected type in the first set (ECMP is configured), it will select the first direct next hop from the remaining set. This is not a deterministic selection and will vary for each SPF calculation.
8. If there is more than one LFA next hop within the selected type in the second set (ECMP is configured), it will pick the tunneled next hop with the lowest cost from the endpoint of the LSP to the destination prefix. If there remains more than one next hop, it will pick the tunneled next hop with the lowest tunnel ID.

### 5.3.2.2 Forwarding adjacency

The forwarding adjacency feature allows IS-IS to advertise an RSVP-TE LSP as a link so that other routers in the network can include it in the SPF calculations. The RSVP-TE is advertised as an unnumbered point-to-point link and the link-state PDU (LSP) has no traffic engineering opaque sub-TLVs as per RFC 3906, *Calculating Interior Gateway Protocol (IGP) Routes Over Traffic Engineering Tunnels*.

The forwarding adjacency feature can be enabled independently from the IGP shortcut feature. If both features are enabled for an IS-IS instance, forwarding adjacency takes precedence.

When forwarding adjacency is enabled, each node advertises a point-to-point unnumbered link for each best-metric tunnel to the router ID of any endpoint node. The node does not include the tunnels as IGP shortcuts in the SPF calculation directly. Instead, when the LSP advertising the corresponding point-to-point unnumbered link is installed in the local routing database, the node performs an SPF calculation using the link like any other link LSP. The link bidirectional check requires that a regular link or tunnel link exist in the reverse direction for the tunnel to be used in SPF calculations.

### 5.3.2.3 IGP shortcut configuration

To enable the use of IGP shortcuts by IS-IS, enter the following command at the IS-IS instance level:

```
config>router>isis>rsvp-shortcut
```

To enable forwarding adjacency, enter the following command at the IS-IS instance level:

```
config>router>isis>advertise-tunnel-link
```

To enable the use of an RSVP-TE LSP by IS-IS as a shortcut or as a forwarding adjacency for resolving IGP routes, enter the following command:

```
config>router>mpls>lsp>igp-shortcut
```

When the **rsvp-shortcut** or **advertise-tunnel-link** option is enabled at the IS-IS instance level, all RSVP-TE LSPs originating on this node are eligible by default as long as the destination address of the LSP, as configured with the **config>router> mpls>lsp>to** command, corresponds to a router ID of a remote node. A specific LSP can be excluded from being used as a shortcut or forwarding adjacency with the **no** form of the **igp-shortcut** command.

### 5.3.3 LFA SPF policies

An LFA SPF policy allows the user to apply specific criteria to the selection of an LFA backup next hop for a subset of prefixes that resolve to a specific primary next hop. The 7705 SAR supports the following LFA SPF policy constraints:

- admin group
- shared risk link group (SRLG)
- protection type
- next-hop type

A route next-hop policy template must first be created under the global router context. The template contains criteria for the policies in the preceding list.

The template is then applied to prefixes protected by LFA. Each instance of IS-IS can apply the same policy template to one or more prefixes and interfaces. If a template is modified, IS-IS re-evaluates it for any changes and, if necessary, schedules a new LFA SPF to recalculate the LFA next hop for any prefixes associated with the template.

As a related feature, prefixes that match a prefix entry in a prefix policy can be excluded from the LFA SPF calculation. If a prefix is excluded, it is not included in the LFA SPF calculation, regardless of its priority. Prefix policies are created with the **config>router>policy-options>prefix-list** command (for information about prefix lists, see the 7705 SAR Router Configuration Guide, "Route Policies").

### 5.3.3.1 LFA SPF policy configuration

To create a route next-hop policy template, enter the following command:

**config>router>route-next-hop-policy template**

Configure the template with policy constraints for the items in the preceding list.



**Note:** To configure constraints for admin groups and SRLG groups, these groups must already be created in the **config>router>if-attribute>admin-group** and **config>router>if-attribute>srlg-group** contexts.

Next, apply the template to IS-IS interfaces by entering the following command:

**config>router>isis>interface>lfa-policy-map>route-nh-template**

The template is applied to all prefixes using the specified interface name.

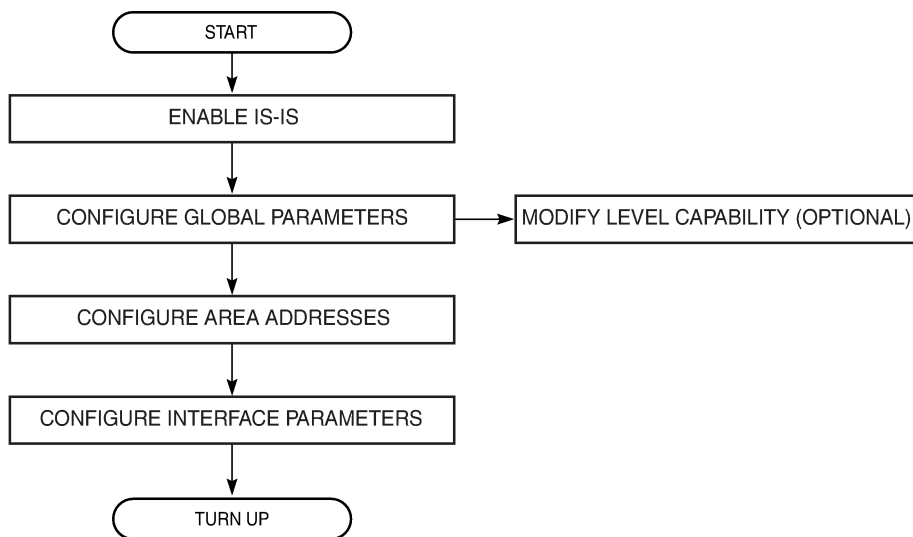
Optionally, exclude prefixes in a prefix policy from the LFA SPF calculation by entering the following command:

**config>router>isis>loopfree-alternates>exclude>prefix-policy**

## 5.4 IS-IS configuration process overview

The following figure shows the process to provision basic IS-IS parameters.

Figure 35: IS-IS configuration process



21826



## 5.5 Configuration notes

- IS-IS must be enabled on each participating 7705 SAR.
- There are no default NETs.
- There are no default interfaces.
- By default, 7705 SAR routers are assigned a level 1/2 capability.

## 5.6 Configuring IS-IS with CLI

This section provides information to configure IS-IS using the command line interface.

Topics in this section include:

- [IS-IS configuration overview](#)
- [Basic IS-IS configuration](#)
- [Configuring IS-IS components](#)
- [IS-IS configuration management tasks](#)

## 5.7 IS-IS configuration overview

The 7705 SAR supports multi-instance IS-IS (MI-IS-IS). For IS-IS to operate on 7705 SAR routers, IS-IS must be explicitly enabled for each instance, and at least one area address and interface must be configured for the instance. If IS-IS is enabled but no area address or interface is configured, no routes are exchanged. When at least one area address and interface are configured, adjacencies can be formed and routes exchanged.

## 5.8 Basic IS-IS configuration

The basic IS-IS configuration tasks that must be performed are:

- enable IS-IS
- modify the level capability on the global level from the default level 1/2 (if required)
- define area addresses
- configure IS-IS interfaces

The following output displays IS-IS default values:

```
Dut-B>config>router>isis# info detail
-----
no router-id
level-capability level-1/2
no auth-keychain
no authentication-key
no authentication-type
```

```
authentication-check
csnp-authentication
no ignore-lsp-errors
lsp-lifetime 1200
lsp-mtu-size 1492
no database-export
no overload
no overload-on-boot
no export
hello-authentication
psnp-authentication
no traffic-engineering
no reference-bandwidth
no disable-ldp-sync
no advertise-router-capability
no rsvp-shortcut
no advertise-tunnel-link
no ignore-attached-bit
no suppress-attached-bit
no iid-tlv-enable
no poi-tlv-enable
no loopfree-alternates
ipv4-routing
no ipv6-routing
no unicast-import-disable ipv4
no multicast-import ipv4
no strict-adjacency-check
entropy-label
    override-tunnel-elc
exit
timers
    lsp-wait 5000 lsp-initial-wait 10 lsp-second-wait 1000
    spf-wait 10000 spf-initial-wait 1000 spf-second-wait 1000
exit
level 1
    advertise-router-capability
    no auth-keychain
    no authentication-key
    no authentication-type
    csnp-authentication
    no database-export-exclude
    external-preference 160
    hello-authentication
    no loopfree-alternate-exclude
    preference 15
    psnp-authentication
    no wide-metrics-only
exit
level 2
    advertise-router-capability
    no auth-keychain
    no authentication-key
    no authentication-type
    csnp-authentication
    no database-export-exclude
    external-preference 165
    hello-authentication
    no loopfree-alternate-exclude
    preference 18
    psnp-authentication
    no wide-metrics-only
exit
segment-routing
shutdown
```

```
        adj-sid-hold 15
        entropy-label enable
        export-tunnel-table ldp
        no prefix-sid-range
        tunnel-table-pref 11
        no tunnel-mtu
        mapping-server
            shutdown
        exit
    exit
    no shutdown
-----
Dut-B>config>router>isis#
```

## 5.9 Configuring IS-IS components

The following sections show the CLI syntax for:

- [Enabling IS-IS](#)
- [Configuring an IS-IS instance level](#)
- [Configuring ISO area addresses](#)
- [Configuring global IS-IS parameters](#)
- [Configuring interface parameters](#)
- [Configuring authentication](#)
- [Configuring leaking](#)
- [Redistributing external IS-IS routes](#)
- [Configuring IS-IS support for LDP-to-SR stitching](#)
- [Configuring an SR mapping server for IPv4 /32 prefixes](#)

### 5.9.1 Enabling IS-IS

An IS-IS instance must be enabled in order for the protocol to be active. If the **isis** command is used without an *isis-instance* specified, the default ("base") instance is used.



**Note:** Careful planning is essential when implementing commands that can affect the behavior of global and interface levels.

To configure an IS-IS instance on a router, enter the following command:

**CLI syntax:**

```
config
  router router-name
    isis [isis-instance]
```

## 5.9.2 Configuring an IS-IS instance level

When an IS-IS instance is enabled, the global default level capability is level 1/2. This means that the instance operates with both level 1 and level 2 routing capabilities. To change the default value in order for the instance to operate as a level 1 router or a level 2 router only, you must explicitly modify the **level-capability** value.

Select **level-1** to route traffic only within an area. Select **level-2** to route traffic to destinations outside an area, toward other eligible level 2 routers.

If the **level-capability** is modified, the protocol restarts, which will likely affect adjacencies and routes.

The **level-capability** value can be configured at the global level and on a per-interface level. The **level-capability** value determines which level values can be assigned on the router instance level or on an interface level.

The **level** command configures parameters for level 1 or level 2 instances (or both).

To configure the router instance level, enter the following command:

### CLI syntax:

```
config>router# isis [isis-instance]
    level-capability {level-1 | level-2 | level-1/2}
    level (1 | 2)
```

The following example displays a level configuration:

```
A:ALU-A>config>router>isis# info
-----
    level-capability level-1/2
    level 1
        no hello-authentication
        preference 150
    level 2
        preference 200
-----
A:ALU-A>config>router>isis#
```

If the default value is not modified on any routers in the area, the routers try to form both level 1 and level 2 adjacencies on all IS-IS interfaces. If the default values are modified to level 1 or level 2, the number of adjacencies formed are limited to that level only. See [Interface level capability](#) for information about the types of adjacencies that can be established depending on the global and interface level values.

## 5.9.3 Configuring ISO area addresses

The **area-id** command specifies the area address portion of the NET, which is used to define the IS-IS area to which the router will belong. At least one area ID must be configured per instance for each router participating in IS-IS; a maximum of three area IDs are supported. Use the following syntax to configure an ISO area address.

For more information about area addresses, see [ISO network addressing](#).

### CLI syntax:

```
config>router# isis [isis-instance]
    area-id area-address
```

The following example shows the commands to configure the area ID.

**Example:**

```
config>router>isis#
config>router>isis# area-id 49.0180.0001
config>router>isis# area-id 49.0180.0002
config>router>isis# area-id 49.0180.0003
```

The following example displays an area ID configuration:

```
A:ALU-A>config>router>isis# info
-----
    area-id 49.0180.0001
    area-id 49.0180.0002
    area-id 49.0180.0003
-----
A:ALU-A>config>router>isis#
```

## 5.9.4 Configuring global IS-IS parameters

Commands and parameters configured on the global level are inherited by the interface levels. Parameters specified in the interface configuration override the global configuration for that interface.

Use the following syntax to configure global IS-IS parameters:

**CLI syntax:**

```
config>router# isis [isis-instance]
    level-capability {level-1 | level-2 | level-1/2}
    [no] authentication-check
    authentication-key {authentication-key|hash-key}[hash | hash2]
    authentication-type {password | message-digest}
    overload [timeout seconds] [max-metric]
    overload-on-boot [timeout seconds] [max-metric]
    traffic-engineering
```

The following example displays a global level configuration:

```
A:ALU-A>config>router>isis# info
-----
    level-capability level-2
    area-id 49.0180.0001
    area-id 49.0180.0002
    area-id 49.0180.0003
    authentication-key "H5vv6WrAAQU" hash
    authentication-type password
    overload timeout 90
    overload-on-boot timeout 90
    traffic-engineering
-----
A:ALU-A>config>router>isis#
```

## 5.9.5 Configuring interface parameters

By default, there are no interfaces associated with IS-IS. You must configure at least one IS-IS interface in order for IS-IS to work. An interface belongs to all areas configured on a router. Interfaces cannot belong to separate areas.

To enable IS-IS on an interface, first configure an IP interface in the **config>router>interface** context. Then, apply the interface in the **config>router>isis>interface** context.

The **level-capability** value can be configured on an interface. The default value is level 1/2. You can configure both level 1 parameters and level 2 parameters on an interface. The **level-capability** value determines which level values are used.



**Note:** For point-to-point interfaces, only the values configured under level 1 are used, regardless of the operational level of the interface.

Use the following syntax to configure interface parameters:

### CLI syntax:

```
config>router# isis [isis-instance]
  level {1 | 2}
    [no] wide-metrics-only
  interface ip-int-name
    level-capability {level-1 | level-2 | level-1/2}
    mesh-group [value | blocked]
    interface-type {broadcast | point-to-point}
```

The following example displays a global level and interface configuration:

```
-----
A:ALU-A>config>router>isis# info
  level-capability level-2
  area-id 49.0180.0001
  area-id 49.0180.0002
  area-id 49.0180.0003
  authentication-key "H5vv6WrAAQU" hash
  authentication-type password
  traffic-engineering
  level 1
    wide-metrics-only
  exit
  level 2
    wide-metrics-only
  exit
  interface "system"
  exit
  interface "ALU-1-2"
    level-capability level-2
    mesh-group 85
  exit
  interface "ALU-1-3"
    level-capability level-1
    interface-type point-to-point
    mesh-group 101
  exit
  interface "ALU-1-5"
    level-capability level-1
    interface-type point-to-point
    mesh-group 85
```

```

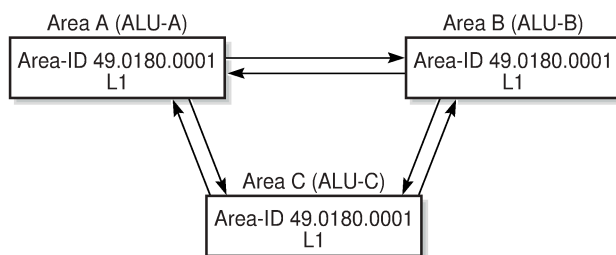
exit
interface "to-103"
  mesh-group 101
exit
-----
A:ALU-A>config>router>isis#

```

### 5.9.5.1 Example 1: configuring a level 1 area

Interfaces are configured in the `config>router>interface` context. The following figure shows a level 1 area configuration.

Figure 36: Configuring a level 1 area



24297

The following example shows the commands to configure a level 1 area:

#### Example:

```

A:ALU-A>config>router# isis
..>isis# area-id 49.0180.0001
..>isis# level-capability level-1
..>isis# interface system
..>isis>if# exit
..>isis# interface "A-B"
..>isis>if# exit
..>isis# interface "A-C"
..>isis>if# exit
..>isis#
A:ALU-B>config>router# isis
..>isis# area-id 49.0180.0001
..>isis# level-capability level-1
..>isis# interface system
..>isis>if# exit
..>isis# interface "B-A"
..>isis>if# exit
..>isis# interface "B-C"
..>isis>if# exit
..>isis#
A:ALU-C>config>router# isis
..>isis# area-id 49.0180.0001
..>isis# level-capability level-1
..>isis# interface system
..>isis>if# exit
..>isis# interface "C-A"
..>isis>if# exit
..>isis# interface "C-B"
..>isis>if# exit

```

The following example displays a level 1 area configuration:

```
A:ALU-A>config>router>isis# info
-----
  level-capability level-1
  area-id 49.0180.0001
  interface "system"
  exit
  interface "A-B"
  exit
  interface "A-C"
  exit
-----
A:ALU-A>config>router>isis#

A:ALU-B>config>router>isis# info
-----
  level-capability level-1
  area-id 49.0180.0001
  interface "system"
  exit
  interface "B-A"
  exit
  interface "B-C"
  exit
-----
A:ALU-B>config>router>isis#

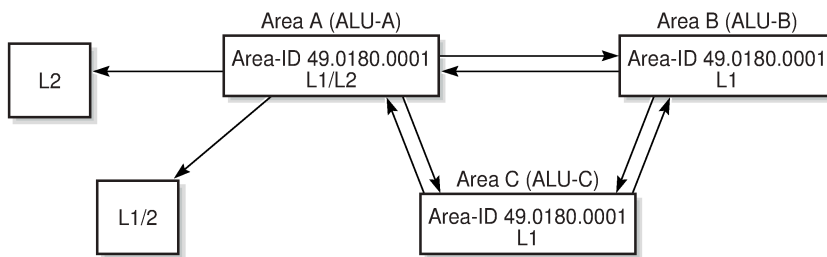
A:ALU-C>config>router>isis# info
#-----
echo "ISIS"
-----
  level-capability level-1
  area-id 49.0180.0001
  interface "system"
  exit
  interface "C-A"
  exit
  interface "C-B"
  exit
-----
A:ALU-C>config>router>isis#
```

### 5.9.5.2 Example 2: modifying router level capability

In the previous example, ALU-A, ALU-B, and ALU-C are configured as level 1 systems. Level 1 systems communicate with other level 1 systems in the same area. In this example, ALU-A is modified to set the level capability to level 1/2. Now the level 1 systems in the area with NET 49.0180.0001 forward PDUs to ALU-A for destinations that are not in the local area, as shown in the following figure.



Figure 37: Configuring a level 1/2 area



24298

The following example shows the commands to configure a level 1/2 area for ALU-A:

**Example:**

```
A:ALU-A>config>router# isis
..>isis# level-capability level-1/2
```

### 5.9.5.3 Interface level capability

The level capability value configured on the interface level is compared to the level capability value configured on the global level to determine the type of adjacencies that can be established. The default value for 7705 SAR routers and interfaces is level 1/2. The following table lists capability combinations and the potential adjacencies that can be formed.

Table 64: Potential adjacency capabilities

Global level	Interface level	Potential adjacency
Level 1/2	Level 1/2	Level 1 or level 2 (or both)
Level 1/2	Level 1	Level 1 only
Level 1/2	Level 2	Level 2 only
Level 2	Level 1/2	Level 2 only
Level 2	Level 2	Level 2 only
Level 2	Level 1	None
Level 1	Level 1/2	Level 1 only
Level 1	Level 2	None
Level 1	Level 1	Level 1 only

### 5.9.6 Configuring authentication

Authentication must be explicitly configured and can be done using two separate mechanisms:

- configuration of an explicit authentication key and algorithm using the **authentication-key** and **authentication-type** commands in the IS-IS global or IS-IS level contexts; configuration of a Hello PDU authentication key using the **hello-authentication-key** and **hello-authentication-type** commands in the IS-IS interface and IS-IS interface level contexts
- configuration of an authentication keychain using the **auth-keychain** command in the **config>system>security>keychain** context and associating the keychain in the applicable IS-IS contexts

Either the **authentication-key** command or the **auth-keychain** command can be used by IS-IS, but both cannot be supported at the same time. If both commands are configured, the **auth-keychain** configuration will be applied and the **authentication-key** command will be ignored.

Use the following CLI syntax to configure authentication:

**CLI syntax:**

```
config>router# isis [isis-instance]
[no] authentication-check
authentication-key {authentication-key | hash-key}[hash | hash2]
authentication-type {password | message-digest}
[no] hello-authentication
level {1 | 2}
    authentication-key {authentication-key | hash-key}[hash | hash2]
    authentication-type {password | message-digest}
```

**CLI syntax:**

```
config>router# isis [isis-instance]
interface ip-int-name
    [no] hello-authentication
    hello-authentication-key {authentication-key | hash-key}[hash |
hash2]
    hello-authentication-type {password | message-digest}
    level {1 | 2}
        hello-authentication-key {authentication-key | hash-key}[hash
| hash2]
        hello-authentication-type {password | message-digest}
```

Use the following CLI syntax to associate IS-IS at the global level or IS-IS level with an authentication keychain and to associate an IS-IS interface or interface level with a Hello authentication keychain. The keychain must already be defined in the **system>security>keychain** context.

**CLI syntax:**

```
config>router# isis [isis-instance]
auth-keychain name
level {1 | 2}
    auth-keychain name
```

**CLI syntax:**

```
config>router# isis [isis-instance]
interface ip-int-name
    hello-auth-keychain name
    level {1 | 2}
        hello-auth-keychain name
```

## 5.9.7 Configuring leaking

IS-IS allows a two-level hierarchy to route PDUs. Level 1 areas can be interconnected by a contiguous level 2 backbone.

The level 1 link-state database contains information only about that area. The level 2 link-state database contains information about the level 2 system and each of the level 1 systems in the area. A level 1/2 router contains information about both level 1 and level 2 databases. A level 1/2 router advertises information about its level 1 area toward the other level 1/2 or level 2 routers.

Packets with destinations outside the level 1 area are forwarded toward the closest level 1/2 router which, in turn, forwards the packets to the destination area.

Sometimes the shortest path to an outside destination is not through the closest level 1/2 router, or the only level 1/2 router to forward packets out of an area is not operational. Route leaking provides a mechanism to leak level 2 information to level 1 routers to provide routing information about inter-area routes. Route leaking therefore gives a level 1 router more options to forward packets.

Configure a route policy to leak routes from level 2 into level 1 areas in the **config>router>policy-options>policy-statement** context. For more information about creating route policies, see the 7705 SAR Router Configuration Guide.

The following example shows the commands to configure prefix list ("loops") and policy statement ("leak") parameters in the **config>router** context.

### Example:

```
config>router>policy-options# prefix-list loops
..>policy-options>prefix-list# prefix 10.1.1.0/8 longer
..>policy-options>prefix-list# exit
..>policy-options# policy-statement leak
..>policy-options>policy-statement# entry 10
..>policy-options>policy-statement>entry# from          list loops
..>policy-options>policy-statement>entry>from# prefix-  level 2
..>policy-options>policy-statement>entry>from# level 2
..>policy-options>policy-statement>entry>from# exit
..>policy-options>policy-statement>entry# to
..>policy-options>policy-statement>entry>to# level 1
..>policy-options>policy-statement>entry>to# exit
..>policy-options>policy-statement>entry# action accept
..>policy-options>policy-statement>entry>action# exit
..>policy-options>policy-statement>entry# exit
..>policy-options>policy-statement# exit
..>policy-options# commit
..>policy-options#
```

The following example displays a prefix list and policy statement configuration:

```
A:ALU-A>config>router>policy-options# info
-----
prefix-list "loops"
  prefix 10.1.1.0/8 longer
exit
policy-statement "leak"
  entry 10
    from
      prefix-list "loop"
      level 2
    exit
  to
```

```

                level 1
                exit
                action accept
                exit
            exit
        exit
    -----
A:ALU-A>config>router>policy-options#

```

Next, apply the policy in order to leak routes from level 2 into level 1 routers on ALU-A:

**CLI syntax:**

```

config>router# isis [isis-instance]
export leak

```

```

A:ALU-A>config>router>isis# info
-----
area-id 49.0180.0001
area-id 49.0180.0002
area-id 49.0180.0003
authentication-key "//oZrvL4FPn06nyRIJ5E" hash
authentication-type password
no authentication-check
export "leak"
...
-----
A:ALU-A>config>router>isis#

```

Then, after the policy is applied, create a policy statement ("isis-ext") to redistribute external IS-IS routes from level 1 routers into the level 2 backbone (see [Redistributing external IS-IS routes](#)). In the **config>router** context, configure the following policy statement parameters:

**Example:**

```

config>router>policy-options# begin
..>policy-options# policy-statement "isis-ext"
..>policy-options>policy-statement# entry 10
..>policy-options>policy-statement>entry$ from
..>policy-options>policy-statement>entry>from$ external
..>policy-options>policy-statement>entry>from# exit
..>policy-options>policy-statement>entry# to
..>policy-options>policy-statement>entry>to$ level 2
..>policy-options>policy-statement>entry>to# exit
..>policy-options>policy-statement>entry# action accept
..>policy-options>policy-statement>entry>action# exit
..>policy-options>policy-statement>entry# exit
..>policy-options>policy-statement# exit
..>policy-options# commit

```

### 5.9.8 Redistributing external IS-IS routes

By default, IS-IS does not redistribute level 1 external routes into level 2. The policy to redistribute external IS-IS routes must be explicitly applied. Policies are created in the **config>router>policy-options** context. See the 7705 SAR Router Configuration Guide for information about creating policies.

The following example displays the policy statement configuration:

```

A:ALU-A>config>router>policy-options# info

```

```

-----
prefix-list "loops"
  prefix 10.1.1.0/8 longer
exit
policy-statement "leak"
  entry 10
    from
      prefix-list "loop"
      level 2
    exit
    to
      level 1
    exit
    action accept
    exit
  exit
exit
policy-statement "isis-ext"
  entry 10
    from
      external
    exit
    to
      level 2
    exit
    action accept
    exit
  exit
exit
-----
A:ALU-A>config>router>policy-options#

```

### 5.9.9 Configuring IS-IS support for LDP-to-SR stitching

Configure the **export-tunnel-table** command using the following CLI syntax to support LDP-to-SR stitching.

**CLI syntax:**

```

config>router# isis
  segment-routing
    export-tunnel-table ldp

```

The following example displays the LDP-to-SR stitching IS-IS configuration output.

```

A:NOK-1 Dut-A>config>router>isis# info detail
-----
    ....
    segment-routing
      ....
      export-tunnel-table ldp
      ....
      exit
    exit
    no shutdown
-----
A:NOK-1 Dut-A>config>router>isis#

```

## 5.9.10 Configuring an SR mapping server for IPv4 /32 prefixes

Use the following CLI syntax to configure an SR mapping server for IPv4 /32 prefixes:

### CLI syntax:

```
config>router# isis [isis-instance]
      segment-routing
      mapping-server
      sid-map node-sid {index value [range value]} prefix {ip-
address/mask | ip-address netmask} [set-flags {s}] [level {1 | 2 | 1/2}]
```

The following is an example of an SR mapping server configuration.

### Example:

```
config>router>isis 1
config>router>isis$ segment-routing
config>router>isis>segm-rtng$ mapping-server
config>router>isis>segm-rtng>map-serv$ sid-map node-sid index 10 range 10
  prefix 10.10.10.10/32 set-flags s level 1
config>router>isis>segm-rtng>map-serv$ exit
config>router>isis>segm-rtng$ exit
config>router>isis$ exit
```

The following example displays the SR mapping server configuration.

```
A:NOK-1 Dut-A>config>router>isis# info detail
-----
...
  segment-routing
    mapping-server
      shutdown
      sid-map node-sid index 10 range 10 prefix 10.10.10.10/32 set-
      flags s level 1
    exit
  exit
  no shutdown
-----
A:NOK-1 Dut-A>config>router>isis#
```

## 5.10 IS-IS configuration management tasks

This section discusses the following IS-IS configuration management tasks:

- [Disabling IS-IS](#)
- [Removing IS-IS](#)
- [Modifying global IS-IS parameters](#)
- [Modifying IS-IS interface parameters](#)

### 5.10.1 Disabling IS-IS

The **shutdown** command disables an IS-IS instance on the router. The configuration settings are not changed, reset, or removed.

Use the following CLI syntax to disable an IS-IS instance on a router:

**CLI syntax:**

```
config>router# isis [isis-instance]
shutdown
```

## 5.10.2 Removing IS-IS

The **no isis** command deletes an IS-IS instance and reverts its configuration to default values for its next use.

Use the following CLI syntax to remove an IS-IS instance:

**CLI syntax:**

```
config>router#
no isis [isis-instance]
```

## 5.10.3 Modifying global IS-IS parameters

You can modify, disable, or remove global IS-IS parameters without shutting down entities. The changes are applied immediately. Modifying the level capability on the global level causes the IS-IS instance to restart.

The following example displays an IS-IS global parameter modification.

**Example:**

```
config>router>isis# overload timeout 500
config>router>isis# level-capability level-1/2
config>router>isis# no authentication-check
config>router>isis# authentication-key raider123
```

The following example displays the IS-IS configuration with the modifications entered in the previous example:

```
A:ALU-A>config>router>isis# info
-----
area-id 49.0180.0001
area-id 49.0180.0002
area-id 49.0180.0003
authentication-key "//oZrvtvFPn06nyRIJ5E" hash
authentication-type password
no authentication-check
overload timeout 500
level 1
    wide-metrics-only
exit
level 2
    wide-metrics-only
exit
interface "system"
exit
interface "ALU-1-2"
    level-capability level-2
    mesh-group 85
exit
```

```

interface "ALU-1-3"
  level-capability level-1
  interface-type point-to-point
  mesh-group 101
exit
interface "ALU-1-5"
  level-capability level-1
  interface-type point-to-point
  mesh-group 85
exit
interface "to-103"
  mesh-group 101
exit
interface "A-B"
exit
interface "A-C"
exit

```

### 5.10.4 Modifying IS-IS interface parameters

You can modify, disable, or remove interface level IS-IS parameters without shutting down entities. Changes take effect immediately. Modifying the level capability on the interface causes the IS-IS instance on the interface to restart.

To remove an interface, use the **no interface** *ip-int-name* command.

To disable an interface, use the **shutdown** command in the interface context.

The following example displays an IS-IS interface parameter modification.

#### Example:

```

config>router# isis
config>router>isis# interface ALU-1-3
config>router>isis>if# mesh-group 85
config>router>isis>if# passive
config>router>isis>if# lsp-pacing-interval 5000
config>router>isis>if# exit
config>router>isis# interface to-103
config>router>isis>if# hello-authentication-type message-digest
config>router>isis>if# hello-authentication-key 49ersrule
config>router>isis>if# exit

```

The following example displays the IS-IS configuration with the modifications entered in the previous example:

```

A:ALU-A>config>router>isis# info
-----
area-id 49.0180.0001
area-id 49.0180.0002
area-id 49.0180.0003
authentication-key "//oZrvtvFPn06nyRIJ5E" hash
authentication-type password
no authentication-check
overload timeout 500
level 1
  wide-metrics-only
exit
level 2
  wide-metrics-only
exit

```



```
interface "system"
exit
interface "ALU-1-2"
    level-capability level-2
    mesh-group 85
exit
interface "ALU-1-3"
    level-capability level-1
    interface-type point-to-point
    lsp-pacing-interval 5000
    mesh-group 85
    passive
exit
interface "ALU-1-5"
    level-capability level-1
    interface-type point-to-point
    mesh-group 85
exit
interface "to-103"
    hello-authentication-key "DvR5l2xxB6XMTvbAZ1mE" hash
    hello-authentication-type message-digest
    mesh-group 101
exit
interface "A-B"
exit
-----
A:ALU-A>config>router>isis#
```

## 5.11 IS-IS command reference

### 5.11.1 Command hierarchies

- [Configuration commands](#)
- [Show commands](#)
- [Clear commands](#)
- [Monitor commands](#)
- [Debug commands](#)
- Tools Commands (see the Tools chapter in the 7705 SAR OAM and Diagnostics Guide)

#### 5.11.1.1 Configuration commands

```

config
- router
  - [no] isis [isis-instance]
    - advertise-router-capability {area | as}
    - no advertise-router-capability
    - [no] advertise-tunnel-link
    - [no] area-id area-address
    - auth-keychain name
    - no auth-keychain
    - [no] authentication-check
    - authentication-key {authentication-key | hash-key} [hash | hash2]
    - no authentication-key
    - authentication-type {password | message-digest}
    - no authentication-type
    - [no] csnp-authentication
    - database-export [identifier id] [bgp-ls-identifier bgp-ls-id]
    - no database-export
    - [no] disable-ldp-sync
    - entropy-label
      - [no] override-tunnel-elc
    - export policy-name [policy-name...(up to 5 max)]
    - no export
    - [no] hello-authentication
    - [no] ignore-attached-bit
    - [no] ignore-lsp-errors
    - [no] iid-tlv-enable
    - [no] interface ip-int-name
      - [no] bfd-enable ipv4
      - csnp-interval seconds
      - no csnp-interval
      - hello-auth-keychain name
      - no hello-auth-keychain
      - [no] hello-authentication
      - hello-authentication-key {authentication-key | hash-key} [hash | hash2]
      - no hello-authentication-key
      - hello-authentication-type {password | message-digest}
      - no hello-authentication-type
      - interface-type {broadcast | point-to-point}
      - no interface-type
      - ipv4-adjacency-sid label value

```

```

- no ipv4-adjacency-sid
- [no] ipv4-multicast-disable
- ipv4-node-sid index index-value
- ipv4-node-sid label label-value
- ipv6-adjacency-sid label value
- no ipv6-adjacency-sid
- [no] ipv6-multicast-disable
- ipv6-node-sid index index-value
- ipv6-node-sid label label-value
- no ipv6-node-sid
- [no] ipv6-unicast-disable
- level {1 | 2}
  - hello-auth-keychain name
  - no hello-auth-keychain
  - hello-authentication-key {authentication-key | hash-key} [hash | hash2]
  - no hello-authentication-key
  - hello-authentication-type {password | message-digest}
  - no hello-authentication-type
  - hello-interval seconds
  - no hello-interval
  - hello-multiplier multiplier
  - no hello-multiplier
  - ipv4-multicast-metric ipv4-multicast-metric
  - no ipv4-multicast-metric
  - ipv6-multicast-metric ipv6-multicast-metric
  - no ipv6-multicast-metric
  - ipv6-unicast-metric ipv6-metric
  - no ipv6-unicast-metric
  - metric metric
  - no metric
  - [no] passive
  - priority number
  - no priority
- level-capability {level-1 | level-2 | level-1/2}
- no level-capability
- lfa-policy-map route-nh-template template-name
- no lfa-policy-map
- [no] loopfree-alternate-exclude
- lsp-pacing-interval milliseconds
- no lsp-pacing-interval
- mesh-group [value | blocked]
- no mesh-group
- [no] passive
- retransmit-interval seconds
- no retransmit-interval
- [no] shutdown
- [no] sid-protection
- ipv4-multicast-routing {native | mt}
- no ipv4-multicast-routing
- [no] ipv4-routing
- ipv6-multicast-routing {native | mt}
- no ipv6-multicast-routing
- ipv6-routing {native | mt}
- no ipv6-routing
- level {1 | 2}
  - auth-keychain name
  - no auth-keychain
  - authentication-key {authentication-key | hash-key} [hash | hash2]
  - no authentication-key
  - authentication-type {password | message-digest}
  - no authentication-type
  - [no] csnp-authentication
  - default-ipv4-multicast-metric ipv4-multicast-metric
  - no default-ipv4-multicast-metric

```

```

- default-ipv6-multicast-metric ipv6-multicast-metric
- no default-ipv6-multicast-metric
- default-ipv6-unicast-metric ipv6-metric
- no default-ipv6-unicast-metric
- default-metric ipv4-metric
- no default-metric
- external-preference external-preference
- no external-preference
- [no] hello-authentication
- [no] loopfree-alternate-exclude
- preference preference
- no preference
- [no] psnp-authentication
- [no] wide-metrics-only
- level-capability {level-1 | level-2 | level-1/2}
- no level-capability
- [no] loopfree-alternates
- exclude
  - prefix-policy prefix-policy [prefix-policy...(up to 5 max)]
  - no prefix-policy
- remote-lfa [max-pq-cost value]
- no remote-lfa
  - node-protect [max-pq-nodes value]
  - no node-protect
- ti-lfa [max-sr-frr-labels value]
- no ti-lfa
  - [no] node-protect
- lsp-lifetime seconds
- no lsp-lifetime
- lsp-mtu-size size
- no lsp-mtu-size
- [no] multi-topology
  - [no] ipv4-multicast
  - [no] ipv6-multicast
  - [no] ipv6-unicast
- [no] multicast-import [{both | ipv4 | ipv6}]
- overload [timeout seconds] [max-metric]
- no overload
- overload-on-boot [timeout seconds] [max-metric]
- no overload-on-boot
- [no] poi-tlv-enable
- [no] psnp-authentication
- reference-bandwidth bandwidth-in-kbps
- reference-bandwidth [tbps Tera-bps] [gbps Giga-bps] [mbps Mega-bps] [kbps Kilo-
bps]
- no reference-bandwidth
- [no] rsvp-shortcut
- [no] segment-routing
  - adj-sid-hold seconds
  - no adj-sid-hold
  - entropy-label {force-disable | enable}
  - no entropy-label
  - export-tunnel-table ldp
  - no export-tunnel-table
  - [no] mapping-server
  - [no] shutdown
  - sid-map node-sid {index value [range value]} prefix {ip address/mask}
| ip-address netmask} [set-flags {s}] [level {1 | 2 | 1/2}]
  - prefix-sid-range global
  - prefix-sid-range start-label label-value max-index index-value
  - no prefix-sid-range
  - srlb reserved-label-block-name
  - no srlb
  - [no] shutdown

```

```

- tunnel-mtu bytes
- no tunnel-mtu
- tunnel-table-pref preference
- no tunnel-table-pref
- [no] shutdown
- [no] strict-adjacency-check
- summary-address {ip-prefix/prefix-length | ip-prefix [netmask]} level
- no summary-address {ip-prefix/prefix-length | ip-prefix [netmask]}
- [no] suppress-attached-bit
- [no] timers
  - lsp-wait lsp-wait [lsp-initial-wait initial-wait] [lsp-second-wait second-
wait]
  - no lsp-wait
  - spf-wait spf-wait [spf-initial-wait initial-wait] [spf-second-wait second-
wait]
  - no spf-wait
- [no] traffic-engineering
- [no] unicast-import-disable [ipv4]

```

### 5.11.1.2 Show commands

```

show
- router
  - isis all
  - isis [isis-instance]
    - adjacency [ip-int-name | ip-address | nbr-system-id] [detail]
    - capabilities [system-id | lsp-id] [level level]
    - database [system-id | lsp-id] [detail] [level level]
    - hostname
    - interface [ip-int-name | ip-address] [detail]
    - lfa-coverage
    - mapping-server [prefix ip-address [/mask]] [index index] [level level] [flag {s}]
    - prefix-sids [ipv4-unicast | ipv6-unicast | mt mt-id-number] [ip-prefix[/prefix-
length]] [sid sid] [adv-router {system-id | hostname}] [srms | no-srms]
    - routes [ipv4-multicast | ipv6-multicast | ipv4-unicast | ipv6-unicast | mt mt-id-
number] [ip-prefix[/prefix-length]] [alternative] [exclude-shortcut] [detail]
    - spf-log [detail]
    - statistics
    - status
    - summary-address [ip-prefix[/prefix-length]]
    - topology [ipv4-multicast | ipv6-multicast | ipv4-unicast | ipv6-unicast | mt mt-
id-number] [lfa] [detail]

```

### 5.11.1.3 Clear commands

```

clear
- router
  - isis [isis-instance]
    - adjacency [system-id]
    - database [system-id]
    - export
    - spf-log
    - statistics

```

### 5.11.1.4 Monitor commands

```
monitor
- router
- isis [isis-instance]
- statistics [interval seconds] [repeat repeat] [absolute | rate]
```

### 5.11.1.5 Debug commands

```
debug
- router
- isis [isis-instance]
- [no] adjacency [ip-int-name | ip-address | nbr-system-id]
- [no] cspf
- interface [ip-int-name | ip-address]
- no interface
- leak [ip-address]
- no leak
- [no] lsdb [level-number] [system-id | lsp-id]
- [no] misc
- packet [packet-type] [ip-int-name | ip-address | ipv6-address] [detail]
- no packet
- rtm [ip-address]
- no rtm
- [no] spf [level-number] [system-id]
```

## 5.11.2 Command descriptions

- [Configuration commands](#)
- [Show commands](#)
- [Clear commands](#)
- [Monitor commands](#)
- [Debug commands](#)

### 5.11.2.1 Configuration commands

- [Generic commands](#)
- [Global commands](#)
- [Interface commands](#)

#### 5.11.2.1.1 Generic commands

##### shutdown

##### Syntax

[no] shutdown

##### Context

```
config>router>isis
config>router>isis>segment-routing
config>router>isis>segment-routing>mapping-server
config>router>isis>interface
```

##### Description

This command administratively disables the entity. When disabled, an entity does not change, reset, or remove any configuration settings or statistics. Many entities must be explicitly enabled using the **no shutdown** command.

The operational state of the entity is disabled as well as the operational state of any entities contained within. Many objects must be shut down before they can be deleted.

Unlike other commands and parameters where the default state is not indicated in the configuration file, **shutdown** and **no shutdown** are always indicated in system-generated configuration files.

The **no** form of the command puts an entity into the administratively enabled state.

##### Default

IS-IS Global - the IS-IS protocol is created in the **no shutdown** state

IS-IS Interface - when an IP interface is configured as an IS-IS interface, IS-IS on the interface is in the **no shutdown** state by default

### 5.11.2.1.2 Global commands

#### isis

##### Syntax

```
[no] isis [isis-instance]
```

##### Context

```
config>router
```

##### Description

This command activates an IS-IS instance on the router and enables access to the context to define IS-IS parameters.

Instance 0, the base instance, is enabled when the **isis** command is run without specifying an *isis-instance*. Multiple IS-IS instances are enabled by including an *isis-instance* value.

The **no** form of the command deletes the IS-IS instance and removes all configuration parameters.

##### Default

```
no isis
```

##### Parameters

*isis-instance*

the IS-IS instance ID. If no *isis-instance* is specified, instance 0 is used.

**Values** 1 to 31

#### advertise-router-capability

##### Syntax

```
advertise-router-capability {area | as}
```

```
no advertise-router-capability
```

##### Context

```
config>router>isis
```



## Description

This command enables advertisement of a router's capabilities to its neighbors for informational and troubleshooting purposes. A TLV as defined in RFC 4971 advertises the TE Node Capability Descriptor capability.

The parameters (**area** and **as**) control the scope of the capability advertisements.

The **no** form of this command disables this capability.

## Default

no advertise-router-capability

## Parameters

### area

capabilities are only advertised within the area of origin

### as

capabilities are advertised throughout the entire autonomous system

## advertise-tunnel-link

## Syntax

**[no] advertise-tunnel-link**

## Context

config>router>isis

## Description

This command enables the forwarding adjacency feature. With this feature, IS-IS advertises an RSVP-TE LSP as a link so that other routers in the network can include it in their SPF calculations. The RSVP-TE LSP is advertised as an unnumbered point-to-point link and the link-state PDU (LSP) has no traffic engineering opaque sub-TLVs as per RFC 3906.

The forwarding adjacency feature can be enabled independently from the IGP shortcut feature ([rsvp-shortcut](#)). If both features are enabled for a given IS-IS instance, the forwarding adjacency feature takes precedence.

When this feature is enabled, each node advertises a point-to-point unnumbered link for each best-metric tunnel to the router ID of any endpoint node. The node does not include the tunnels as IGP shortcuts in the SPF calculation directly. Instead, when the LSP advertising the corresponding point-to-point unnumbered link is installed in the local routing database, the node performs an SPF calculation using the link like any other link LSP.

The link bidirectional check requires that a regular link or tunnel link exists in the reverse direction for the tunnel to be used in the SPF calculation.

An RSVP-TE LSP can be excluded from being used as a forwarding adjacency with the **config>router>mpls>lsp>no igp-shortcut** command.

The **no** form of this command disables forwarding adjacency and therefore disables the advertisement of RSVP-TE LSPs into IS-IS.

## Default

no advertise-tunnel-link

## area-id

## Syntax

[no] **area-id** *area-address*

## Context

config>router>isis

## Description

This command configures the area ID portion of the network service access point (NSAP) address, which identifies a point of connection to the network, such as a router interface.

Addresses in the IS-IS protocol are based on the ISO NSAP addresses and network entity titles (NETs), not IP addresses. NET addresses are constructed similarly to NSAPs with the exception that the selector ID is always 00. NET addresses are exchanged in Hello and LSP PDUs. All NET addresses configured on the node are advertised to its neighbors.

Up to three area addresses can be configured.

NSAP addresses are divided into three parts. Only the area ID portion is configurable:

- area ID – a variable-length field between 1 and 13 bytes that identifies the area to which the router belongs. This field includes the Authority and Format Identifier (AFI) as the first (most significant) byte and the area identifier.
- system ID – A 6-byte system identifier. This value is not configurable. The system ID is derived from the system or router ID and uniquely identifies the router.
- selector ID – A 1-byte selector identifier that is always 00 for an NET. This value is not configurable.

For level 1 interfaces, neighbors can have different area IDs, but they must have at least one area ID (AFI + area) in common. Sharing a common area ID, they become neighbors and area merging between the potentially different areas can occur.

For level 2 interfaces, neighbors can have different area IDs. However, if they have no area IDs in common, they become only level 2 neighbors and only level 2 LSPs are exchanged.

For level 1/2 interfaces, neighbors can have different area IDs. If they have at least one area ID (AFI + area) in common, they become neighbors. In addition to exchanging level 2 LSPs, area merging between potentially different areas can occur.

If multiple **area-id** commands are entered, the system ID of all subsequent entries must match the system ID of the first area address.

The **no** form of the command removes the area address.

## Default

n/a – no area address is assigned

## Parameters

*area-address*

the area ID, from 1 to 13 bytes (if fewer than 13 bytes are entered, the rest of the field is padded with zeros)

## auth-keychain

### Syntax

**auth-keychain** *name*

**no auth-keychain**

### Context

config>router>isis

config>router>isis>level

### Description

This command associates an authentication keychain with the IS-IS instance or level. The keychain is a collection of keys used to authenticate IS-IS messages from remote peers. The keychain allows the rollover of authentication keys during the lifetime of a session and also supports stronger authentication algorithms than clear text and MD5.

The keychain must already be defined in the **config>system>security>keychain** context.

Either the **authentication-key** command or the **auth-keychain** command can be used by IS-IS, but both cannot be supported at the same time. If both commands are configured, the **auth-keychain** configuration will be applied and the **authentication-key** command will be ignored.

By default, authentication is not enabled.

### Default

no auth-keychain

### Parameters

*name*

the name of an existing keychain, up to 32 characters

## authentication-check

### Syntax

**[no] authentication-check**

### Context

config>router>isis

## Description

This command sets an authentication check to reject PDUs that do not match the type or key requirements.

The default behavior when authentication is configured is to reject all IS-IS protocol PDUs that have a mismatch in either the authentication type or authentication key.

When **no authentication-check** is configured, authentication PDUs are generated and IS-IS PDUs are authenticated on receipt. However, although mismatches cause an event to be generated, the mismatches will not be rejected.

## Default

authentication-check

## authentication-key

## Syntax

**authentication-key** {*authentication-key* | *hash-key*} [**hash** | **hash2**]

**no authentication-key**

## Context

config>router>isis

config>router>isis>level

## Description

This command sets the authentication key used to verify PDUs sent by neighboring routers on the interface. Neighboring routers use passwords to authenticate PDUs sent from an interface. For authentication to work, both the authentication key and the authentication type on a segment must match. The [authentication-type](#) command must also be entered.

To configure authentication on the global level, configure this command in the **config>router>isis** context. When this parameter is configured on the global level, all PDUs are authenticated, including the Hello PDU.

To override the global setting for a specific level, configure the **authentication-key** command in the **config>router>isis>level** context. When configured within the specific level, Hello PDUs are not authenticated.

By default, no authentication key is configured.

Either the **authentication-key** command or the **auth-keychain** command can be used by IS-IS, but both cannot be supported at the same time. If both commands are configured, the **auth-keychain** configuration will be applied and the **authentication-key** command will be ignored.

The **no** form of the command removes the authentication key.

## Default

no authentication-key

## Parameters

### *authentication-key*

the authentication key can be any combination of ASCII characters up to 254 characters in length (unencrypted). If spaces are used in the string, the entire string must be enclosed in double quotes (" ").

### *hash-key*

the hash key can be any combination of ASCII characters up to 352 characters in length (encrypted) or 407 characters in length (if the **hash2** parameter is used). If spaces are used in the string, the entire string must be enclosed in double quotes (" ").

This is useful when a user must configure the parameter, but for security purposes, the actual unencrypted key value is not provided.

### **hash**

specifies that the key is entered in an encrypted form. If the **hash** parameter is not used, the key is assumed to be in a non-encrypted, clear text form. For security, all keys are stored in encrypted form in the configuration file with the **hash** parameter specified.

### **hash2**

specifies that the key is entered in a more complex encrypted form. If the **hash2** parameter is not used, the less encrypted hash form is assumed.

## authentication-type

### Syntax

**authentication-type** {password | message-digest}

**no authentication-type**

### Context

```
config>router>isis
```

```
config>router>isis>level
```

### Description

This command enables either simple password or message-digest authentication in the global IS-IS or IS-IS level context. Both the authentication key and the authentication type on a segment must match. The [authentication-key](#) command must also be entered.

Configure the authentication type at the global level in the **config>router>isis** context. Configure or override the global setting by configuring the authentication type in the **config>router>isis>level** context.

The **no** form of the command disables authentication.

### Default

no authentication-type

## Parameters

### password

enables simple password (plaintext) authentication. If authentication is enabled and no authentication type is specified in the command, simple password authentication is enabled.

### message-digest

enables message-digest MD5 authentication in accordance with RFC 1321. If this option is configured, at least one message-digest-key must be configured.

## csnp-authentication

### Syntax

[no] csnp-authentication

### Context

config>router>isis

config>router>isis>level

### Description

This command enables authentication of individual IS-IS packets of complete sequence number PDUs (CSNPs).

The **no** form of the command suppresses authentication of CSNP packets.

### Default

csnp-authentication

## database-export

### Syntax

database-export [identifier *id*] [bgp-ls-identifier *bgp-ls-id*]

no database-export

### Context

config>router>isis

### Description

This command enables the population of the extended TE database (TE-DB) with the link-state information from the IS-IS instance.

The extended TE-DB is used as a central point for importing all link-state, link, node, and prefix information from IGP instances on the router and exporting the information to BGP-LS on the router. This information includes the IGP, TE, SID sub-TLV, and adjacency SID sub-TLV.

The **no** form of this command disables database exportation.

## Default

no database-export

## Parameters

### identifier

uniquely identifies the IGP instance in the BGP-LS NLRI when a router has interfaces participating in multiple IGP instances. This parameter defaults to the IGP instance ID assigned by the 7705 SAR. However, because the concept of instance ID defined in IS-IS (RFC 6822) is unique within a routing domain while the one specified for OSPF is significant for the local subnet only (RFC 6549), the user can remove any overlap by configuring the new **identifier** value to be unique within a particular IGP domain when this router sends the IGP link-state information using BGP-LS.

*id*

specifies an entry ID to export

**Values** 0 to 18446744073709551615

### bgp-ls-identifier

used with the autonomous system number (ASN) to correlate the BGP-LS NLRI advertisements of multiple BGP-LS speakers in the same IGP domain. If an NRC-P network domain has multiple IGP domains, BGP-LS speakers in each IGP domain must be configured with the same unique tuple {bgp-ls-identifier, asn}.

The BGP-LS identifier is optional and is only sent in a BGP-LS NLRI if configured in the IGP instance of an IGP domain.

If this IGP instance participates in traffic engineering with RSVP-TE or SR-TE, the [traffic-engineering](#) option is not strictly required because enabling the extended TE-DB populates this information automatically. However, it is recommended that the user enable traffic engineering to make the configuration consistent with other routers in the network that do not require enabling of the extended TE-DB.

*bgp-ls-id*

specifies a BGP LS ID to export

**Values** 0 to 4294967295

## disable-ldp-sync

### Syntax

[no] disable-ldp-sync

### Context

config>router>isis

## Description

This command disables the IGP-LDP synchronization feature on all interfaces participating in the OSPF or IS-IS routing protocol. When this command is executed, the IGP immediately advertises the actual value of the link cost for all interfaces that have the IGP-LDP synchronization enabled if the currently advertised cost is different. IGP-LDP synchronization will then be disabled for all interfaces. This command does not delete the interface configuration.

The **no** form of this command restores the default settings and re-enables IGP-LDP synchronization on all interfaces participating in the OSPF or IS-IS routing protocol and for which the **ldp-sync-timer** is configured (see the 7705 SAR Router Configuration Guide for information about configuring the **ldp-sync-timer**).

## Default

no disable-ldp-sync

## entropy-label

## Syntax

**entropy-label**

## Context

config>router>isis

## Description

This command enables the context for the configuration of entropy label capabilities (ELC) for the routing protocol.

## override-tunnel-elc

## Syntax

[no] **override-tunnel-elc**

## Context

config>router>isis>entropy-label

## Description

This command configures the ability to override any received entropy label capability advertisements. When enabled, the system assumes that all nodes for an IGP domain are capable of receiving and processing the entropy label on segment routed tunnels. This command can only be configured if **entropy-label** is enabled via the **config>router>isis>segment-routing>entropy-label** command.

The **no** version of this command disables the override. The system assumes entropy label capability for other nodes in the IGP instance if capability advertisements are received.



## Default

no override-tunnel-enc

## export

## Syntax

**export** *policy-name* [*policy-name*...(up to 5 max)]

**no export**

## Context

config>router>isis

## Description

This command associates export route policies to determine which routes are exported from the route table to IS-IS.

If no export policy is specified, non-IS-IS routes are not exported from the routing table manager to IS-IS.

If multiple policy names are specified, the policies are evaluated in the order they are specified. The first policy that matches is applied. If multiple export commands are issued, the last command entered will override the previous command. A maximum of five policy names can be specified.

The **no** form of the command removes all policies from the configuration.

See the 7705 SAR Router Configuration Guide for information about defining route policies.

## Default

n/a – no export route policies specified

## Parameters

*policy-name*

the export route policy name. Allowed values are any string up to 32 characters long composed of printable, 7-bit ASCII characters. If the string contains special characters (such as #, \$, or spaces), the entire string must be enclosed within double quotes.

The specified names must already be defined.

## hello-authentication

## Syntax

[no] **hello-authentication**

## Context

config>router>isis

config>router>isis>interface

## Description

This command enables authentication of individual IS-IS Hello PDUs.

The **no** form of the command suppresses authentication of Hello PDUs.

## Default

hello-authentication

## ignore-attached-bit

## Syntax

[no] ignore-attached-bit

## Context

config>router>isis

## Description

This command specifies that this level 1 router will ignore the attached (ATT) bit in received level 1 link-state PDUs (LSPs) and therefore will not install the default route to the level 1/2 router that set the ATT bit.

The **no** form of the command specifies that the router will install the default route to the closest level 1/2 router.

## Default

no ignore-attached-bit

## ignore-lsp-errors

## Syntax

[no] ignore-lsp-errors

## Context

config>router>isis

## Description

This command specifies that the router will ignore LSPs with internal checksum errors rather than purging the LSPs.

The **no** form of the command specifies that LSPs with internal checksum errors will be purged, which will cause the originator to resend the LSPs.

## Default

no ignore-lsp-errors

## iid-tlv-enable

### Syntax

```
[no] iid-tlv-enable
```

### Context

```
config>router>isis
```

### Description

This command specifies whether the Instance Identifier (IID) TLV is enabled or disabled for this IS-IS instance so an interface can be used in multiple IS-IS instances.

When enabled, each IS-IS instance marks its packets with the IID TLV containing its unique 16-bit IID for the routing domain. You must use a **shutdown/no shutdown** command sequence on the IS-IS instance to make the change operational.

The **no** form of the command disables the IID TLV marking of packets.

### Default

```
no iid-tlv-enable
```

## ipv4-multicast-routing

### Syntax

```
ipv4-multicast-routing {native | mt}  
no ipv4-multicast-routing
```

### Context

```
config>router>isis
```

### Description

This command controls which IS-IS topology is used to populate the IPv4 multicast routing table manager (RTM). The multicast RTM is used for reverse path forwarding (RPF) checks.

Specifying the **native** keyword allows IPv4 routes from both the MT 0 and the MT 3 topologies in the IPv4 multicast RTM.

Specifying the **mt** keyword allows IPv4 routes from only the MT 3 topology in the IPv4 multicast RTM. IPv4 routes from the IPv4 unicast routing topology (MT 0) are prevented from being added to the multicast RTM.

The **no** form of the command result in no routes being populated in the IPv4 multicast RTM and is used when multicast is configured to use the unicast RTM for RPF checks.

### Default

```
native
```

## Parameters

### native

allows IPv4 routes from both the IPv4 unicast routing topology (MT 0) and the IPv4 multicast routing topology (MT 3) in the multicast RTM

### mt

allows routes only from the IPv4 multicast routing topology (MT 3) in the multicast RTM

## ipv4-routing

### Syntax

[no] **ipv4-routing**

### Context

config>router>isis

### Description

This command enables or disables IPv4 routing on the IS-IS instance.

### Default

ipv4-routing

## ipv6-multicast-routing

### Syntax

**ipv6-multicast-routing** {**native** | **mt**}

**no ipv6-multicast-routing**

### Context

config>router>isis

### Description

This command controls whether IPv6 routes from the MT 2 topology are populated in the IPv6 multicast routing table manager (RTM). The multicast RTM is used for reverse path forwarding (RPF) checks.

Specifying the **native** keyword allows IPv6 routes from both the MT 2 and the MT 4 topologies in the IPv4 multicast RTM.

Specifying the **mt** keyword allows IPv6 routes from only the MT 4 topology in the IPv4 multicast RTM. IPv6 routes from the IPv6 unicast routing topology (MT 2) are prevented from being added to the multicast RTM.

The **no** form of the command result in no routes being populated in the IPv6 multicast RTM and is used when multicast is configured to use the unicast RTM for RPF checks.

**Default**

native

**Parameters****native**

allows IPv6 routes from both the IPv6 unicast routing topology (MT 2) and the IPv6 multicast routing topology (MT 4) in the multicast RTM

**mt**

allows routes only from the IPv6 multicast routing topology (MT 4) in the multicast RTM

**ipv6-routing****Syntax**

**ipv6-routing {native | mt}**

**no ipv6-routing**

**Context**

config>router>isis

**Description**

This command enables IPv6 routing on the IS-IS instance. In native mode, IPv6 routing information is exchanged in IS-IS using IS-IS IPv6 TLVs. In multitopology mode, IPv6 routing information is exchanged in IS-IS using IS-IS multitopology TLVs.

**Default**

no ipv6-routing

**Parameters****native**

specifies that IS-IS IPv6 TLVs be used for IPv6 routing

**mt**

specifies that IS-IS multitopology TLVs be used for IPv6 routing

**level****Syntax**

**level {1 | 2}**

**Context**

config>router>isis

config>router>isis>interface

## Description

This command enables the context to configure IS-IS level 1 or level 2 area attributes.

To reset global and/or interface level parameters to the default, the following commands must be entered independently:

```
- level> no hello-authentication-key
- level> no hello-authentication-type
- level> no hello-interval
- level> no hello-multiplier
- level> no metric
- level> no passive
- level> no priority
```

## Default

level 1 or level 2

## Special cases

### Global IS-IS level

the **config>router>isis** context configures default global parameters for both level 1 and level 2 interfaces

### IS-IS interface level

the **config>router>isis>interface** context configures IS-IS operational characteristics of the interfaces at level 1 and/or level 2. A logical interface can be configured on one level 1 and one level 2 interface. In this case, each level can be configured independently and parameters must be removed independently.

## Parameters

1

specifies that the router or interface is a level 1 router or interface

2

specifies that the router or interface is a level 2 router or interface

## default-ipv4-multicast-metric

## Syntax

**default-ipv4-multicast-metric** *ipv4-multicast-metric*

**no default-ipv4-multicast-metric**

## Context

config>router>isis>level

## Description

This command sets the default metric to be used for the IS-IS interfaces on the specified level in the IPv4 multicast routing topology (MT 3).

The **no** form of the command returns the setting to the system default.

### Default

10

### Parameters

*ipv4-multicast-metric*

the default metric for interfaces in the IPv4 multicast routing topology (MT 3)

**Values** 1 to 16777215

## default-ipv6-multicast-metric

### Syntax

**default-ipv6-multicast-metric** *ipv6-multicast-metric*

**no default-ipv6-multicast-metric**

### Context

config>router>isis>level

### Description

This command sets the default metric to be used for the IS-IS interfaces on the specified level in the IPv6 multicast routing topology (MT 4).

The **no** form of the command returns the setting to the system default.

### Default

10

### Parameters

*ipv6-multicast-metric*

the default metric for interfaces in the IPv6 multicast routing topology (MT 4)

**Values** 1 to 16777215

## default-ipv6-unicast-metric

### Syntax

**default-ipv6-unicast-metric** *ipv6-metric*

**no default-ipv6-unicast-metric**

### Context

config>router>isis>level

## Description

This command sets the default metric to be used for the IS-IS interfaces on the specified level in the IPv6 unicast routing topology (MT 2).

The **no** form of the command returns the setting to the default value.

## Default

10

## Parameters

*ipv6-metric*

the default metric for interfaces in the IPv6 unicast routing topology (MT 2)

**Values** 1 to 16777215

## default-metric

## Syntax

**default-metric** *ipv4-metric*

**no default-metric**

## Context

config>router>isis>level

## Description

This command sets the default metric used for all IS-IS interfaces on the specified level in the IPv4 unicast routing topology (MT 0). This value is not used when a metric is configured for an interface.

The **no** form of the command returns the setting to the default value.

## Default

10

## Parameters

*ipv4-metric*

the default metric for interfaces in the IPv4 unicast routing topology (MT 0)

**Values** 1 to 16777215

## external-preference

## Syntax

**external-preference** *external-preference*

**no external-preference**



## Context

```
config>router>isis>level
```

## Description

This command configures the preference for IS-IS external routes for the IS-IS level. The preference for internal routes is set with the [preference](#) command.

The command configures the preference level for either level 1 or level 2 external routes. The default preferences are listed in the following table.

A route can be learned by the router from different protocols, in which case, the costs are not comparable. When this occurs, the preference is used to decide which route will be used.

Different protocols should not be configured with the same preference. If this occurs, the tiebreaker is based on the default preferences as listed in the table.

*Table 65: Route preference defaults by route type*

Route type	Preference	Configurable
Direct attached	0	No
Static routes	5	Yes
OSPF internal	10	Yes
IS-IS level 1 internal	15	Yes
IS-IS level 2 internal	18	Yes
OSPF external	150	Yes
IS-IS level 1 external	160	Yes
IS-IS level 2 external	165	Yes

If multiple routes are learned with an identical preference using the same protocol, the lowest-cost route is used. If multiple routes are learned with an identical preference using the same protocol and the costs (metrics) are equal, the decision of which route to use is determined by the configuration of ECMP in the **config>router** context. See the 7705 SAR Router Configuration Guide for information about ECMP.



**Note:** To configure a preference for static routes, use the **config>router>static-route-entry** context. See the 7705 SAR Router Configuration Guide for information.

The **no** form of the command reverts to the default value.

## Default

external-preference 160 – for IS-IS level 1 external routes

external-preference 165 – for IS-IS level 2 external routes

## Parameters

*external-preference*

the preference for external routes at this level, expressed as a decimal integer

**Values** 1 to 255

## loopfree-alternate-exclude

### Syntax

[no] **loopfree-alternate-exclude**

### Context

config>router>isis>level

config>router>isis>interface

### Description

This command instructs IS-IS to exclude a specific interface or all interfaces participating in a specific IS-IS level from the LFA SPF calculation. The LFA SPF calculation can therefore be run only where it is needed.

If an interface is excluded from the LFA SPF in IS-IS, it is excluded in both level 1 and level 2.

### Default

no loopfree-alternate-exclude

## preference

### Syntax

**preference** *preference*

**no preference**

### Context

config>router>isis>level

### Description

This command configures the preference for IS-IS level 1 or level 2 internal routes.

A route can be learned by the router from different protocols, in which case, the costs are not comparable. When this occurs, the preference is used to decide which route will be used.

Different protocols should not be configured with the same preference. If this occurs, the tiebreaker is based on the default preferences as listed in [Table 65: Route preference defaults by route type](#). If multiple routes are learned with an identical preference using the same protocol and the costs (metrics) are equal, the decision of which route to use is determined by the configuration of ECMP in the **config>router** context. See the 7705 SAR Router Configuration Guide for information about ECMP.

The **no** form of the command reverts to the default value.

## Default

preference 15 – for IS-IS level 1 internal routes

preference 18 – for IS-IS level 2 internal routes

## Parameters

*preference*

the preference for internal routes expressed as a decimal integer

**Values** 1 to 255

## wide-metrics-only

### Syntax

[no] **wide-metrics-only**

### Context

config>router>isis>level

### Description

This command enables the exclusive use of wide metrics in the LSPs for the level number. Narrow metrics can have values between 1 and 63. IS-IS can generate two TLVs, one for the adjacency and one for the IP prefix. In order to support traffic engineering, wider metrics are required. When wide metrics are used, a second pair of TLVs are added for the adjacency and the IP prefix.

By default, both sets of TLVs are generated. When **wide-metrics-only** is configured, IS-IS only generates the pair of TLVs with wide metrics for that level.

The **no** form of the command reverts to the default value.

### Default

no wide-metrics-only

## level-capability

### Syntax

**level-capability** {level-1 | level-2 | level-1/2}

**no level-capability**

### Context

config>router>isis

config>router>isis>interface

## Description

This command configures the routing level for the IS-IS instance.

An IS-IS router and IS-IS interface can operate at level 1, level 2, or both level 1 and level 2.

A level 1 adjacency can be established if there is at least one area address shared by this router and a neighbor. A level 2 adjacency cannot be established over this interface.

A level 1/2 adjacency is created if the neighbor is also configured as a level 1/2 router and has at least one area address in common. A level 2 adjacency is established if there are no common area IDs.

A level 2 adjacency is established if another router is configured as a level 2 or level 1/2 router with interfaces configured as level 1/2 or level 2. Level 1 adjacencies will not be established over this interface.

The following table lists capability combinations and the potential adjacencies that can be formed.

*Table 66: Potential adjacency capabilities*

Global level	Interface level	Potential adjacency
Level 1/2	Level 1/2	Level 1 or level 2 (or both)
Level 1/2	Level 1	Level 1 only
Level 1/2	Level 2	Level 2 only
Level 2	Level 1/2	Level 2 only
Level 2	Level 2	Level 2 only
Level 2	Level 1	None
Level 1	Level 1/2	Level 1 only
Level 1	Level 2	None
Level 1	Level 1	Level 1 only

The **no** form of the command removes the level capability from the configuration.

## Default

level-1/2

## Special cases

### IS-IS router

in the **config>router>isis** context, changing the level capability performs a restart on the IS-IS protocol instance

### IS-IS interface

in the **config>router>isis>interface** context, changing the level capability performs a restart of IS-IS on the interface

## Parameters

### level-1

specifies that the router or interface can operate at level 1 only

### level-2

specifies that the router or interface can operate at level 2 only

### level-1/2

specifies that the router or interface can operate at both level 1 and level 2

## loopfree-alternates

## Syntax

[no] loopfree-alternates

## Context

config>router>isis

## Description

This command enables loop-free alternate (LFA) computation by SPF for the IS-IS routing protocol.

When this command is enabled, it instructs the IGP SPF to attempt to precalculate both a primary next hop and an LFA backup next hop for every learned prefix. When found, the LFA next hop is populated in the routing table along with the primary next hop for the prefix.

The **no** form of this command disables LFA computation by the IGP SPF.

## Default

no loopfree-alternates

## exclude

## Syntax

exclude

## Context

config>router>isis>loopfree-alternates

## Description

This command enables the context for identifying prefix policies to be excluded from the LFA calculation by IS-IS.

## prefix-policy

### Syntax

**prefix-policy** *prefix-policy* [*prefix-policy*...(up to 5 max)]

**no prefix-policy**

### Context

config>router>isis>loopfree-alternates>exclude

### Description

This command excludes from the LFA SPF calculation any prefixes that match a prefix entry or a tag entry in a prefix policy. If a prefix is excluded, it is not included in the LFA SPF calculation, regardless of its priority. The tag will, however, be used in the main SPF. Prefix policies are created with the command **config>router>policy-options>prefix-list** (for information about prefix lists, see the 7705 SAR Router Configuration Guide, "Route Policies").

The default action of the **loopfree-alternates>exclude>prefix-policy** command, when not explicitly specified in the prefix policy, is to "reject". Therefore, even if the **default-action reject** statement was not explicitly stated for the prefix policy, a prefix that does not match any entry in the policy will be used in the LFA SPF calculation.

The **no** form of the command deletes the excluded prefix policy.

### Default

no prefix-policy

### Parameters

*prefix-policy*

the name of the prefix policy to be excluded from the LFA SPF calculation in this IS-IS instance. Up to five prefixes can be specified. The specified prefix policy must already be defined.

## remote-lfa

### Syntax

**remote-lfa** [**max-pq-cost** *value*]

**no remote-lfa**

### Context

config>router>isis>loopfree-alternates

### Description

This command enables the use of the remote LFA algorithm in the LFA SPF calculation in this IS-IS instance.

When this command is enabled in an IGP instance, SPF performs the additional remote LFA computation that follows the regular LFA next-hop calculation when the latter calculation results in no protection for one or more prefixes that are resolved to a particular interface.

Remote LFA extends the protection coverage of LFA-FRR to any topology by automatically computing and establishing or tearing down shortcut tunnels, also referred to as repair tunnels, to a remote LFA node that puts the packets back into the shortest path without looping them back to the node that forwarded them over the repair tunnel. The remote LFA node is referred to as a PQ node. A repair tunnel can, in theory, be an RSVP-TE LSP, an LDP-in-LDP tunnel, or a segment routing (SR) tunnel. The **remote-lfa** command is restricted to using an SR repair tunnel to the remote LFA node.

The remote LFA algorithm is a per-link LFA SPF calculation and not a per-prefix calculation like the regular LFA algorithm. The remote LFA algorithm provides protection for all destination prefixes that share the protected link by using the neighbor on the other side of the protected link as a proxy for all the destinations.

The **no** form of this command disables the use of the remote LFA algorithm in the LFA SPF calculation in this IS-IS instance.

## Default

no remote-lfa

## Parameters

*value*

specifies the integer used to limit the search for candidate P and Q nodes in the remote LFA algorithm by setting the maximum IGP cost from the router performing the remote LFA calculation to the candidate P or Q node

**Values** 0 to 4294967295

**Default** 4261412864

## node-protect

## Syntax

**node-protect** [**max-pq-nodes** *value*]

**no node-protect**

## Context

config>router>isis>loopfree-alternates>remote-lfa

config>router>isis>loopfree-alternates>ti-lfa

## Description

This command administratively enables the use of the node-protect calculation in the remote LFA algorithm or topology-independent LFA (TI-LFA) algorithm in SPF computations. When node protection is enabled, the router prefers a node-protect repair tunnel over a link-protect repair tunnel for a particular prefix if both tunnels are found in the remote LFA or TI-LFA SPF computation. However, the SPF computations may only find a link-protect repair tunnel for prefixes owned by the protected node.

The **max-pq-nodes** parameter controls the maximum number of candidate PQ nodes found in the LFA SPF for which the node protection check is performed. The node-protect condition means that the router must run the original link-protect remote LFA algorithm plus one extra forward SPF on behalf of each PQ node found, potentially after applying the **max-pq-cost** parameter, to verify that the path from the PQ node to the destination does not traverse the protected node. Setting the **max-pq-nodes** parameter to a lower value means that the LFA SPFs use less computation time and resources; however, this may result in not finding a node-protect repair tunnel.



**Note:** The optional **max-pq-nodes** parameter is available only in the **config>router>isis>loopfree-alternates>remote-lfa** context.

The **no** form of the command disables the node-protect calculation.

## Default

no node-protect

## Parameters

*value*

specifies the maximum number of PQ nodes found in the LFA SPFs for which the node protection check is performed

**Values** 1 to 32

**Default** 16

## ti-lfa

## Syntax

**ti-lfa** [**max-sr-frr-labels** *value*]

**no ti-lfa**

## Context

config>router>isis>loopfree-alternates

## Description

This command enables the use of the topology-independent LFA (TI-LFA) algorithm in the LFA SPF calculation in this IS-IS instance.

The TI-LFA algorithm improves the protection coverage of a network topology by computing and automatically instantiating a repair tunnel to a Q node that is not in the shortest path from the computing node. The repair tunnel uses the shortest path to the P node and a source-routed path from the P node to the Q node.

The TI-LFA repair tunnel can have a maximum of three labels pushed in addition to the label of the destination node or prefix. The user can set a lower maximum value for the additional FRR labels by configuring the **max-sr-frr-labels** option.

The **no** form of this command disables the use of the TI-LFA algorithm in the LFA SPF calculation in the IS-IS instance.



**Default**

no ti-lfa

**Parameters**

*value*

specifies the maximum number of labels that the TI-LFA backup next hop can use. The TI-LFA algorithm uses this value to limit the search for the Q node from the P node on the post-convergence path.

**Values** 0 to 3

**Default** 2

## lsp-lifetime

**Syntax**

**lsp-lifetime** *seconds*

**no lsp-lifetime**

**Context**

config>router>isis

**Description**

This command sets the time interval for LSPs originated by the router to be considered valid by other routers in the domain.

Each LSP received is maintained in an LSP database until the LSP lifetime expires, unless the originating router refreshes the LSP. Each router refreshes its LSPs at the half-life of the **lsp-lifetime** value (by default, every 10 min (600 s)), so that other routers will not age out the LSP.

The **no** form of the command reverts to the default value.

**Default**

1200

**Parameters**

*seconds*

the interval for LSPs originated by the route to be considered valid by other routers in the domain

**Values** 350 to 65335

## lsp-mtu-size

### Syntax

**lsp-mtu-size** *size*

**no lsp-mtu**

### Context

config>router>isis

### Description

This command configures the LSP MTU size. If the MTU size is changed from the default value using the CLI or SNMP, IS-IS must be restarted in order for the change to take effect. This can be done by performing a **shutdown** command and then a **no shutdown** command in the **config>router>isis** context.



**Note:** If the MTU size is changed from the default value by using the **exec** command to execute a configuration file with the changed value, IS-IS will automatically bounce before the change takes effect.

The **no** form of the command reverts to the default value.

### Default

1492

### Parameters

*size*

the LSP MTU size

**Values** 490 to 9702

## multi-topology

### Syntax

**[no] multi-topology**

### Context

config>router>isis

### Description

This command enables IS-IS multitopology support.

The **no** form of the command disables IS-IS multitopology support

### Default

no multitopology

## ipv4-multicast

### Syntax

**[no] ipv4-multicast**

### Context

config>router>isis>multi-topology

### Description

This command enables multitopology TLVs and global support for IPv4 multicast routing topology MT 3 in the associated IS-IS instance.

The **no** form of the command disables the multitopology TLVs and global support.

### Default

no ipv4-multicast

## ipv6-multicast

### Syntax

**[no] ipv6-multicast**

### Context

config>router>isis>multi-topology

### Description

This command enables multitopology TLVs and global support for IPv6 multicast routing topology MT 4 in the associated IS-IS instance.

The **no** form of the command disables the multitopology TLVs and global support.

### Default

no ipv6-multicast

## ipv6-unicast

### Syntax

**[no] ipv6-unicast**

### Context

config>router>isis>multi-topology

## Description

This command enables multitopology TLVs and global support for IPv6 unicast routing topology MT 2 in the associated IS-IS instance.

The **no** form of the command disables the multitopology TLVs and global support.

## Default

no ipv6-unicast

## multicast-import

## Syntax

**[no] multicast-import** [{**both** | **ipv4** | **ipv6**}]

## Context

config>router>isis

## Description

This command enables the submission of IPv4 routes, IPv6 routes, or both IPv4 and IPv6 routes into the multicast routing table manager (RTM) by IS-IS.

The **no** form of the command disables the submission of routes into the multicast RTM.

## Default

no multicast-import

## Parameters

### **both**

specifies that both IPv4 and IPv6 routes are submitted into the RTM

### **ipv4**

specifies that IPv4 routes are submitted into the RTM

### **ipv6**

specifies that IPv6 routes are submitted into the RTM

## overload

## Syntax

**overload** [**timeout** *seconds*] [**max-metric**]

**no overload**

## Context

config>router>isis

## Description

This command administratively sets the IS-IS router to operate in the overload state for a specific time period or indefinitely.

During normal operation, the router may be forced to enter an overload state because of a lack of resources. When in the overload state, the router is only used if the destination is reachable by the router and will not be used for other transit traffic.

If a time period is specified, the overload state persists for the configured length of time. If no time is specified, the overload state operation is maintained indefinitely.

The **overload** command can be useful in circumstances where the router is overloaded or used before executing a **shutdown** command to divert traffic around the router.

The **max-metric** parameter can be set to advertise transit links with the maximum metric value of 0x3f (63 decimal) for regular metrics or 0xfffffe (16 777 214 decimal) for wide metrics when placing the router in overload, instead of using the overload bit.

The **no** form of the command causes the router to exit the overload state.

## Default

no overload

## Parameters

*seconds*

the number of seconds that the router remains in the overload state

**Values** 60 to 1800

**Default** infinity (overload state maintained indefinitely)

**max-metric**

advertises transit links with the maximum metric instead of setting the overload bit

## overload-on-boot

## Syntax

**overload-on-boot** [*timeout seconds*] [**max-metric**]

**no overload-on-boot**

## Context

config>router>isis

## Description

This command configures IS-IS in the overload state upon boot-up until one of the following events occurs:

- the timeout timer expires
- the current overload state is manually overridden with the **no overload** command

When the router is in an overload state, the router is used only if there is no other router to reach the destination.

The **no overload** command does not affect the **overload-on-boot** function. If the overload state is cleared with the **no overload** command, the router will still re-enter the overload state after rebooting.

If no timeout is specified, IS-IS will go into the overload state indefinitely after a reboot. After the reboot, the IS-IS status will display a permanent overload state:

- L1 LSDB Overload : Manual on boot (Indefinitely in overload)
- L2 LSDB Overload : Manual on boot (Indefinitely in overload)

This state can be cleared with the **no overload** command.

If a timeout value is specified, IS-IS will go into the overload state for the configured timeout after a reboot. After the reboot, the IS-IS status will display the remaining time that the system stays in overload:

- L1 LSDB Overload : Manual on boot (Overload Time Left : 17)
- L2 LSDB Overload : Manual on boot (Overload Time Left : 17)

The overload state can be cleared before the timeout expires with the **no overload** command.

The **max-metric** parameter can be set to advertise transit links with the maximum metric value of 0x3f (63 decimal) for regular metrics or 0xfffffe (16 777 214 decimal) for wide metrics when placing the router in overload, instead of using the overload bit.

The **no** form of the command removes the overload-on-boot functionality from the configuration.

## Default

no overload-on-boot

## Parameters

*seconds*

the number of seconds that the router remains in the overload state after rebooting

**Values** 60 to 1800

**Default** 60

**max-metric**

advertises transit links with the maximum metric instead of setting the overload bit

## poi-tlv-enable

## Syntax

[no] poi-tlv-enable

## Context

config>router>isis

## Description

This command enables the use of the Purge Originator Identification (POI) TLV for this IS-IS instance. The POI is added to purges and contains the system ID of the router that generated the purge, which simplifies troubleshooting and determining what caused the purge. The **no** form of this command removes the POI functionality from the configuration.

## Default

no poi-tlv-enable

## psnp-authentication

## Syntax

[no] psnp-authentication

## Context

config>router>isis

config>router>isis>level

## Description

This command enables authentication of individual IS-IS packets of partial sequence number PDUs (PSNPs).

The **no** form of the command suppresses authentication of PSNP packets.

## Default

psnp-authentication

## reference-bandwidth

## Syntax

**reference-bandwidth** *bandwidth-in-kbps*

**reference-bandwidth** [**tbps** *Tera-bps*] [**gbps** *Giga-bps*] [**mbps** *Mega-bps*] [**kbps** *Kilo-bps*]

**no reference-bandwidth**

## Context

config>router>isis

## Description

This command configures the reference bandwidth used to calculate the default costs of interfaces based on their underlying link speed.

The default interface cost is calculated as follows:

cost = reference bandwidth/bandwidth

If the reference bandwidth is configured as 10 Gbytes (10 000 000 000), a 100 Mb/s interface has a default metric of 100. In order for metrics in excess of 63 to be configured, wide metrics must be deployed (see the [wide-metrics-only](#) command).

If the reference bandwidth is not configured, all interfaces have a default metric of 10.

The **no** form of the command resets the reference bandwidth to the default value.

## Default

no reference-bandwidth (all interfaces have a metric of 10)

## Parameters

### *bandwidth-in-kbps*

the reference bandwidth in kilobits per second, expressed as a decimal integer

**Values** 1 to 400000000

### *Tera-bps*

the reference bandwidth in terabits per second, expressed as a decimal integer

**Values** 1 to 4

### *Giga-bps*

the reference bandwidth in gigabits per second, expressed as a decimal integer

**Values** 1 to 999

### *Mega-bps*

the reference bandwidth in megabits per second, expressed as a decimal integer

**Values** 1 to 999

### *Kilo-bps*

the reference bandwidth in kilobits per second, expressed as a decimal integer

**Values** 1 to 999

## rsvp-shortcut

## Syntax

**rsvp-shortcut**

**no rsvp-shortcut**

## Context

config>router>isis



## Description

This command enables the use of an RSVP-TE shortcut for resolving IS-IS routes. When the command is enabled, IS-IS includes RSVP-TE LSPs originating on this node and terminating on the router ID of a remote node as direct links with a metric equal to the operational metric provided by MPLS.

The SPF algorithm will always use the IGP metric to build the SPF tree, and the LSP metric value does not update the SPF tree calculation. During the IP reach to determine the reachability of nodes and prefixes, LSPs are overlaid and the LSP metric is used to determine the subset of paths that are of an equal lowest cost to reach a node or a prefix. If the **relative-metric** option for this LSP is enabled (in the **config>router>mpls>lsp>igp-shortcut** context), IS-IS will apply the shortest cost between the endpoints of the LSP plus the value of the offset, instead of the LSP operational metric, when calculating the cost of a prefix that is resolved to the LSP.

When a prefix is resolved to a tunnel next hop, the packet is sent labeled with the label stack corresponding to the NHLFE of the RSVP-TE LSP. Any network event that causes an RSVP-TE LSP to go down will trigger a full SPF calculation, which may result in a new route being installed over another RSVP-TE LSP shortcut as a tunnel next hop or over a regular IP next hop.

When the **rsvp-shortcut** command is enabled, all RSVP-TE LSPs originating on this node are eligible by default as long as the destination address of the LSP, as configured with the **config>router>mpls>lsp>to** command, corresponds to a router ID of a remote node. A specific LSP can be excluded from being used as a shortcut with the **config>router>mpls>lsp>no igp-shortcut** command.

If ECMP is enabled on the system and multiple equal-cost paths exist for the route over a set of tunnel next hops (based on the hashing routine supported for IPv4 packets), there are two possibilities:

- if the destination is the tunnel endpoint, the system selects the tunnel with the lowest tunnel ID (the IP next hop is never used)
- if the destination is different from the tunnel endpoint, the system:
  - selects tunnel endpoints where the LSP metric is lower than the IGP cost
  - prefers tunnel endpoints over IP next hops

ECMP is not performed across both the IP and tunnel next hops.

IS-IS can populate the multicast RTM with the prefix IP next hop when both **rsvp-shortcut** and **multicast-import** are enabled. The unicast RTM can still use the tunnel next hop for the same prefix.

The forwarding adjacency feature (**advertise-tunnel-link**) can be enabled independently from the shortcuts feature. If both features are enabled for a given IS-IS instance, the forwarding adjacency feature takes precedence.

The **no** form of this command disables the resolution of IGP routes using RSVP shortcuts.

## Default

no rsvp-shortcut

## segment-routing

## Syntax

[no] segment-routing

## Context

```
config>router>isis
```

## Description

This command enables the context to configure segment routing parameters within an IGP instance.

Segment routing adds to IS-IS and OSPF routing protocols the ability to perform shortest path routing and source routing using the concept of abstract segment. An abstract segment can represent a local prefix of a node, a specific adjacency of the node (interface or next-hop), a service context, or a specific explicit path over the network. For each segment, the IGP advertises an identifier referred to as the segment ID (SID).

When segment routing is used together with the MPLS data plane, the SID is a standard MPLS label. A router forwarding a packet using segment routing will push one or more MPLS labels.

Segment routing using MPLS labels can be used in both shortest path routing applications and traffic engineering applications. On the 7705 SAR, segment routing implements the shortest path forwarding application.

After segment routing is successfully enabled in the IS-IS instance or in OSPF, the router will perform the following operations:

- advertise the Segment Routing Capability sub-TLV to routers in all areas or levels of this IGP instance. However, only neighbors with which the IGP instance established an adjacency will interpret the SID and label range information and use it for calculating the label to swap to or push for a particular resolved prefix SID.
- advertise the assigned index for each configured node SID in the new prefix SID sub-TLV with the N-flag (node SID flag) set. The segment routing module then programs the incoming label map (ILM) with a pop operation for each local node SID in the data path.
- automatically assign and advertise an adjacency SID label for each formed adjacency over a network IP interface in the new Adjacency SID sub-TLV. The segment routing module programs the incoming label map (ILM) with a pop operation, in effect with a swap to an implicit null label operation, for each advertised adjacency SID.
- resolve received prefixes, and if a prefix SID sub-TLV exists, the segment routing module programs the ILM with a swap operation and programs an LSP ID to NHLFE (LTN) with a push operation, both pointing to the primary/LFA NHLFE. An SR tunnel is also added to the TTM.

When the user enables segment routing in an IGP instance, the main SPF and LFA SPF are computed normally and the primary next hop and LFA backup next hop for a received prefix are added to the RTM without the label information advertised in the prefix SID sub-TLV.

## adj-sid-hold

### Syntax

```
adj-sid-hold seconds
```

```
no adj-sid-hold
```

### Context

```
config>router>isis>segment-routing
```

## Description

This command configures a timer to hold the ILM or LTN of an adjacency SID following a failure of the adjacency.

When an adjacency to a neighbor fails, the IGP will withdraw the advertisement of the link TLV information as well as its adjacency SID sub-TLV. However, the ILM or LTN record of the adjacency SID must be kept in the data path to maintain forwarding using the LFA or remote LFA backup for a sufficient length of time to allow the ingress LER and other routers that use this adjacency SID to activate a new path after the IGP converges.

If the adjacency is restored before the timer expires, the timer is aborted as soon as the new ILM or LTN records are updated with the new primary and backup NHLFE information.

The **no** form of the command removes the adjacency SID hold time.

## Default

15

## Parameters

*seconds*

the adjacency SID hold time, in seconds

**Values** 1 to 300

## entropy-label

## Syntax

**entropy-label** {**force-disable** | **enable**}

**no entropy-label**

## Context

config>router>isis>segment-routing

## Description

This command, when used with the **force-disable** keyword, instructs the system to ignore any received IGP advertisements of entropy label capability relating to remote nodes in the network. The command also prevents a user from configuring **override-tunnel-elic** for the IGP instance.

The **no** version of this command enables the processing of any received IGP advertisements of entropy label capability. Using the **enable** keyword has the same effect.

## Default

entropy-label enable

## Parameters

### **force-disable**

forces the system to ignore any received advertisements of entropy label capability signaled in the IGP

### **enable**

enables the system to process any received advertisements of entropy label capability signaled in the IGP

## export-tunnel-table

## Syntax

**export-tunnel-table** *ldp*

**no export-tunnel-table**

## Context

config>router>isis>segment-routing

## Description

This command enables the exporting of LDP tunnels from the TTM to an IGP instance for the purpose of stitching an SR tunnel to an LDP FEC for the same destination IPv4 /32 prefix.

When this command is enabled, the IGP monitors the LDP tunnel entries in the TTM. Whenever an LDP tunnel destination matches a prefix for which IGP received a prefix SID sub-TLV from the mapping server, the IGP instructs the SR module to program the SR ILM and to stitch it to the LDP tunnel endpoint.

The **no** form of this command disables the exporting of LDP tunnels to the IGP instance.

## Default

no export-tunnel-table

## Parameters

### **ldp**

exports LDP tunnels from the TTM to an IGP instance

## mapping-server

## Syntax

**[no] mapping-server**

## Context

config>router>isis>segment-routing

## Description

This command enables the context to enable the SR mapping server feature for an IS-IS instance.

The mapping server feature allows the configuration and advertisement via IS-IS of the node SID index for IS-IS prefixes of routers that are in the LDP domain. The router that is acting as a mapping server uses a prefix SID sub-TLV within the SID/Label Binding TLV in IS-IS to advertise a node SID index.

The **no** form of this command deletes the mapping server.

## sid-map

## Syntax

**sid-map node-sid** {**index value** [**range value**]} **prefix** {*ip-address/mask* | *ip-address netmask*} [**set-flags** {**s**}] [**level** {**1** | **2** | **1/2**}]

**no sid-map node-sid index value**

## Context

config>router>isis>segment-routing>mapping-server

## Description

This command configures the SR mapping server database for an IS-IS instance.

The **node-sid** index can be configured for one prefix or a range of prefixes by specifying the index value or a value range.

Only the first prefix in a consecutive range of prefixes must be entered. If the first prefix has a mask lower than 32, the SID/Label Binding TLV is advertised but the router does not resolve the prefix SIDs; a trap is originated instead.

The **set-flags s** option indicates to the IS-IS network routers that the flooding of the SID/Label Binding TLV applies to the entire domain. A router that receives the TLV advertisement leaks it between IS-IS levels 1 and 2. If leaked from level 2 to level 1, the D-flag must be set; this prevents the TLV from being leaked back into level 2. The S-flag is not defined by default; if it is not configured, the TLV is not leaked by routers receiving the mapping server advertisement.

The **level** option specifies the mapping server's flooding scope for the generated SID/Label Binding TLV using t. The default flooding scope of the mapping server is level 1/2.

The **no** form of this command deletes the range of node SIDs beginning with the specified index value.

## Parameters

**index value**

specifies the node SID index for the IS-IS prefix that will be advertised in a SID/Label Binding TLV

**Values** 0 to 4294967295

**range value**

specifies the node SID range for the IS-IS prefixes that will be advertised in a SID/Label Binding TLV

**Values** 0 to 65535

*ip-address*

specifies the IP address

**Values** a.b.c.d. (host bits must be 0)

*mask*

specifies the subnet mask

**Values** 0 to 32

*netmask*

specifies the subnet mask in dotted-decimal notation

**Values** 0.0.0.0 to 255.255.255.255

**set-flags s**

specifies that the flooding of the SID/Label Binding TLV applies to the entire domain

**level {1 | 2 | 1/2}**

specifies the mapping server flooding scope for the generated SID/Label Binding TLV

**Default** 1/2

## prefix-sid-range

### Syntax

**prefix-sid-range global**

**prefix-sid-range start-label label-value max-index index-value**

**no prefix-sid-range**

### Context

config>router>isis>segment-routing

### Description

This command configures the prefix SID index range and offset label value for an IGP instance.

The key parameter is the configuration of the prefix SID index range and the offset label value that this IGP instance will use. Because each prefix SID represents a network global IP address, the SID index for a prefix must be unique network-wide. Therefore, all routers in the network are expected to configure and advertise the same prefix SID index range for an IGP instance. However, the label value used by each router to represent this prefix, that is, the label programmed in the ILM, can be local to that router by the use of an offset label, referred to as a start label:

*Local Label (Prefix SID) = start-label + {SID index}*

The label operation in the network is very similar to LDP when operating in the independent label distribution mode (RFC 5036, *LDP Specification*), with the difference that the label value used to forward a

packet to each downstream router is computed by the upstream router based on the advertised prefix SID index using the above formula.

There are two mutually exclusive modes of operation for the prefix SID range on the router: global mode and per-instance mode.

In global mode, the user configures the global value and the IGP instance assumes that the start label value is the lowest label value in the Segment Routing Global Block (SRGB) and the prefix SID index range size is equal to the range size of the SRGB. When one IGP instance selects the **global** option for the prefix SID range, all IGP instances on the system must do the same. The user must shut down the segment routing context and disable the **prefix-sid-range** command in all IGP instances in order to change the SRGB. When the SRGB is changed, the user must re-enable the **prefix-sid-range** command. The SRGB range change will fail if an already allocated SID index/label goes out of range.

In per-instance mode, the user partitions the SRGB into non-overlapping sub-ranges among the IGP instances. The user configures a subset of the SRGB by specifying the start label value and the prefix SID index range size. All resulting net label values (start-label + index) must be within the SRGB or the configuration will fail. The 7705 SAR checks for overlaps of the resulting net label value range across IGP instances and will strictly enforce no overlapping of these ranges. The user must shut down the segment routing context of an IGP instance in order to change the SID index/label range of that IGP instance using the **prefix-sid-range** command. A range change will fail if an already allocated SID index/label goes out of range. The user can change the SRGB without shutting down the segment routing context as long as it does not reduce the current per-IGP instance SID index/label range defined with the **prefix-sid-range** command. Otherwise, the user must shut down the segment routing context of the IGP instance, and disable and re-enable the **prefix-sid-range** command.

## Default

no prefix-sid-range

## Parameters

### *label-value*

specifies the label offset for the SR label range of this IGP instance

**Values** 0 to 524287

### *index-value*

specifies the maximum value of the prefix SID index range for this IGP instance

**Values** 1 to 524287

## srlb

## Syntax

**srlb** *reserved-label-block-name*

**no srlb**

## Context

config>router>isis>segment-routing

## Description

This command specifies the reserved label block to use for the segment routing local block (SRLB) for this IS-IS instance. The reserved label block must first be configured in the **config>router>mpls-labels** context.

The **no** form of the command removes the SRLB.

## Default

no srlb

## Parameters

*reserved-label-block-name*

the name of the reserved label block

## tunnel-mtu

## Syntax

**tunnel-mtu** *bytes*

**no tunnel-mtu**

## Context

config>router>isis>segment-routing

## Description

This command configures the MTU of all SR tunnels within each IGP instance.

The MTU of an SR tunnel populated into the TTM is determined in the same way as the MTU of an IGP tunnel (for example, an LDP LSP) based on the outgoing interface MTU minus the label stack size.

Remote LFA can add, at most, one more label to the tunnel for a total of two labels. There is no default value for this command. If the user does not configure an SR tunnel MTU, the MTU, in bytes, is determined by IGP as follows:

$$SR\_Tunnel\_MTU = MIN \{ Cfg\_SR\_MTU, IGP\_Tunnel\_MTU - (1 + frr-overhead) \times 4 \}$$

where:

- *Cfg\_SR\_MTU* is the MTU configured by the user for all SR tunnels within an IGP instance using the **tunnel-mtu** command. If no value is configured by the user, the SR tunnel MTU is determined by the IGP interface calculation described in the following bullet point
- *IGP\_Tunnel\_MTU* is the minimum of the IS-IS or OSPF interface MTU among all the ECMP paths or among the primary and LFA backup paths of this SR tunnel
- *frr-overhead* is set to 1 if the **segment-routing** and **remote-lfa** options are enabled in the IGMP instance. Otherwise, it is set to 0.

The SR tunnel MTU is dynamically updated whenever any of the above parameters used in its calculation changes. This includes if the set of the tunnel next hops changes or the user changes the configured SR MTU or interface MTU value.



**Default**

no tunnel-mtu

**Parameters***bytes*

specifies the size of the MTU in bytes

**Values** 512 to 9198**tunnel-table-pref****Syntax****tunnel-table-pref** *preference***no tunnel-table-pref****Context**

config&gt;router&gt;isis&gt;segment-routing

**Description**

This command configures the TTM preference of shortest path SR tunnels created by the IGP instance. This is used for BGP shortcuts, VPRN autobind, or BGP transport tunnel when the tunnel binding commands are configured to the **any** value, which parses the TTM for tunnels in the protocol preference order. The user can choose either the global TTM preference or explicitly list the tunnel types they want to use. If the user lists the tunnel types explicitly, the TTM preference is still used to select one type over the other. In both cases, a fallback to the next preferred tunnel type is performed if the selected type fails. A reversion to a more preferred tunnel type is performed as soon as one is available.

The segment routing module adds to the TTM an SR tunnel entry for each resolved remote node SID prefix and programs the data path having the corresponding LTN with the push operation pointing to the primary and LFA backup NHLFEs.

The default preference for shortest path SR tunnels in the TTM is set lower than LDP tunnels but higher than BGP tunnels to allow controlled migration of customers without disrupting their current deployment when they enable segment routing. The following list shows the value of the default preference for the various tunnel types. This includes the preference of SR tunnels based on shortest path (referred to as SR-ISIS and SR-OSPF).



**Note:** The preference of the SR-TE LSP is not configurable and is the second most preferred tunnel type after RSVP-TE. The preference is the same whether the SR-TE LSP was resolved in IS-IS or OSPF.

The global default TTM preference for the tunnel types is as follows:

ROUTE_PREF_RSVP	7
ROUTE_PREF_SR_TE	8
ROUTE_PREF_LDP	9

ROUTE_PREF_SR_OSPF_TTM	10
ROUTE_PREF_SR_ISIS_TTM	11
ROUTE_PREF_BGP_TTM	12
ROUTE_PREF_GRE	255

The default value for SR-ISIS is the same regardless of whether one or more IS-IS instances programmed a tunnel for the same prefix. The selection of an SR tunnel in this case is based on the lowest IGP instance ID.

### Default

11

### Parameters

*preference*

specifies the integer value to represent the preference of IS-IS SR tunnels in the TTM

**Values** 1 to 255

## strict-adjacency-check

### Syntax

[no] **strict-adjacency-check**

### Context

config>router>isis

### Description

This command enables strict checking of address families (IPv4 and IPv6) for IS-IS adjacencies. When enabled, adjacencies will not come up unless both routers have exactly the same address families configured. If there is an existing adjacency with unmatched address families, it will be torn down. By ensuring that adjacencies are only established if both routers have the same address families, this command prevents the blackholing of traffic that may occur when IPv4 and IPv6 topologies are different.

When the command is disabled, both routers only need to have one common address family to establish the adjacency. A BFD session failure for either IPv4 or IPv6 will cause the routes for the other address family to be removed as well.

### Default

no strict-adjacency-check

## summary-address

### Syntax

**summary-address** {*ip-prefix/prefix-length* | *ip-prefix* [*netmask*]} **level**

**no summary-address** {*ip-prefix/prefix-length* | *ip-prefix* [*netmask*]}

### Context

config>router>isis

### Description

This command creates summary addresses.

### Default

no summary-address

### Parameters

*ip-prefix/prefix-length*

the IPv4 or IPv6 prefix and prefix length

*netmask*

the subnet mask in dotted-decimal notation

**level**

the IS-IS level

**Values** level-1, level-2, level-1/2

## suppress-attached-bit

### Syntax

[no] **suppress-attached-bit**

### Context

config>router>isis

### Description

This command suppresses the setting of the attached (ATT) bit in level 1 LSPs originated by this level 1/2 router to prevent all level 1 routers in the area from installing a default route to this router.

The **no** form of the command enables the setting of the ATT bit.

### Default

no suppress-attached-bit

## timers

### Syntax

[no] timers

### Context

config>router>isis

### Description

This command configures the IS-IS timer values.

## lsp-wait

### Syntax

**lsp-wait** *lsp-wait* [**lsp-initial-wait** *initial-wait*] [**lsp-second-wait** *second-wait*]

**no lsp-wait**

### Context

config>router>isis>timers

### Description

This command is used to customize LSP generation throttling. Timers that determine when to generate the first, second, and subsequent LSPs can be controlled with this command. Subsequent LSPs are generated at increasing intervals of the second **lsp-wait** timer until a maximum value is reached.



**Note:** The IS-IS timer granularity is 100 ms. Timer values are rounded down to the nearest supported value; for example, a configured value of 550 ms is internally rounded down to 500 ms.

### Default

lsp-wait 5000

### Parameters

*lsp-wait*

the maximum interval, in milliseconds, between two consecutive occurrences of an LSP being generated

**Values** 10 to 120000

**Default** 5000

*initial-wait*

the initial LSP generation delay, in milliseconds. Values less than 100 ms are internally rounded down to 0, so that there is no added initial LSP generation delay.

**Values** 10 to 100000

**Default** 10

#### *second-wait*

the hold time, in milliseconds, between the first and second LSP generation

**Values** 10 to 100000

**Default** 1000

## spf-wait

### Syntax

**spf-wait** *spf-wait* [**spf-initial-wait** *initial-wait*] [**spf-second-wait** *second-wait*]

**no spf-wait**

### Context

config>router>isis>timers

### Description

This command defines the maximum interval, in milliseconds, between two consecutive SPF calculations. Timers that determine when to initiate the first, second, and subsequent SPF calculations after a topology change occurs can be controlled with this command.

Subsequent SPF runs (if required) will occur at exponentially increasing intervals of the **spf-second-wait** interval. For example, if the **spf-second-wait** interval is 1000, the next SPF will run after 2000 ms, the SPF after that will run after 4000 ms, and so on, until it reaches the **spf-wait** value. The SPF interval will stay at the **spf-wait** value until there are no more SPF runs scheduled in that interval. After a full interval without any SPF runs, the SPF interval will drop back to the **spf-initial-wait** value.



**Note:** The IS-IS timer granularity is 100 ms. Timer values are rounded down to the nearest supported value; for example, a configured value of 550 ms is internally rounded down to 500 ms.

### Default

spf-wait 10000

### Parameters

#### *spf-wait*

the maximum interval, in milliseconds, between two consecutive SPF calculations

**Values** 10 to 120000

**Default** 10000

#### *initial-wait*

the initial SPF calculation delay, in milliseconds, after a topology change

**Values** 10 to 100000

**Default** 1000

*second-wait*

the hold time, in milliseconds, between the first and second SPF calculation

**Values** 10 to 100000

**Default** 1000

## traffic-engineering

### Syntax

[no] traffic-engineering

### Context

config>router>isis

### Description

This command enables traffic engineering and determines if IGP shortcuts are required.

The **no** form of the command disables traffic-engineered route calculations.

### Default

no traffic-engineering

## unicast-import-disable

### Syntax

[no] unicast-import-disable [ipv4]

### Context

config>router>isis

### Description

This command allows one IGP to import its routes into the multicast RTM (also known as the RPF RTM [Reverse Path Forwarding - Route Table Manager]) while another IGP imports routes only into the unicast RTM. Import policies can redistribute routes from an IGP protocol into the RPF RTM. By default, the IGP routes will not be imported into the RPF RTM because such an import policy must be explicitly configured.

The **no** form of the command enables importing IGP routes into the RPF RTM.

### Default

no unicast-import-disable ipv4

### 5.11.2.1.3 Interface commands

#### interface

##### Syntax

**[no] interface** *ip-int-name*

##### Context

config>router>isis

##### Description

This command enables the context to configure an IS-IS interface.

When an area is defined, the interfaces belong to that area. Interfaces cannot belong to other areas.

If the interface is a POS channel, the OSI Network Layer Control Protocol (OSINLCP) is enabled when the interface is created and removed when the interface is deleted.

The **no** form of the command deletes the IS-IS interface configuration for this interface. The **shutdown** command in the **config>router>isis>interface** context can be used to disable an interface without removing the configuration for the interface.

##### Default

no interface

##### Parameters

*ip-int-name*

the IP interface name. Interface names must be unique within the group of defined IP interfaces for the **config>router>interface** command. An interface name cannot be in the form of an IP address. Interface names can be any string up to 32 characters long composed of printable, 7-bit ASCII characters. If the string contains special characters (such as #, \$, or spaces), the entire string must be enclosed within double quotes.

#### bfd-enable

##### Syntax

**[no] bfd-enable ipv4**

##### Context

config>router>isis>interface

##### Description

This command enables the use of bidirectional forwarding (BFD) to control IPv4 adjacencies. By enabling BFD on a given IS-IS interface, the state of the interface is tied to the state of the BFD session between the

local node and the remote node. The parameters used for BFD are set via the BFD command under the IP interface.

The **no** form of this command removes BFD from the associated IPv4 adjacency.

### Default

no bfd-enable ipv4

## csnp-interval

### Syntax

**csnp-interval** *seconds*

**no csnp-interval**

### Context

config>router>isis>interface

### Description

This command configures the interval, in seconds, to send complete sequence number PDUs (CSNPs) from the interface. IS-IS must send CSNPs periodically.

The **no** form of the command reverts to the default value.

### Default

csnp-interval 10 – CSN PDUs are sent every 10 s for LAN interfaces

csnp-interval 5 – CSN PDUs are sent every 5 s for point-to-point interfaces

### Parameters

*seconds*

the CSNP interval expressed in seconds

**Values** 1 to 65535

## hello-auth-keychain

### Syntax

**hello-auth-keychain** *name*

**no hello-auth-keychain**

### Context

config>router>isis>interface

config>router>isis>interface>level



## Description

This command associates a Hello authentication keychain with the IS-IS interface or interface level. The keychain is a collection of keys used to authenticate IS-IS messages from remote peers. The keychain allows the rollover of authentication keys during the lifetime of a session and also supports stronger authentication algorithms than clear text and MD5.

The keychain must already be defined in the **config>system>security>keychain** context.

Either the **hello-authentication-key** command or the **hello-auth-keychain** command can be used by IS-IS, but both cannot be supported at the same time. If both commands are configured, the **hello-auth-keychain** configuration will be applied and the **hello-authentication-key** command will be ignored.

## Default

no hello-auth-keychain

## Parameters

*name*

the name of the keychain, up to 32 characters

## hello-authentication-key

## Syntax

**hello-authentication-key** {*authentication-key* | *hash-key*} [**hash** | **hash2**]

**no hello-authentication-key**

## Context

config>router>isis>interface

config>router>isis>interface>level

## Description

This command configures the authentication key (password) for Hello PDUs. Neighboring routers use the password to verify the authenticity of Hello PDUs sent from this interface. Both the Hello authentication key and the Hello authentication type on a segment must match. The [hello-authentication-type](#) command must also be entered.

To configure the Hello authentication key for all levels configured for the interface, use the **hello-authentication-key** command in the **config>router>isis>interface** context.

To configure or override the Hello authentication key for a specific level, use the **hello-authentication-key** command in the **config>router>isis>interface>level** context.

If both IS-IS authentication and Hello authentication are configured, Hello messages are validated using Hello authentication. If only IS-IS authentication is configured, it will be used to authenticate all IS-IS protocol PDUs, including Hello PDUs.

Either the **hello-authentication-key** command or the **hello-auth-keychain** command can be used by IS-IS, but both cannot be supported at the same time. If both commands are configured, the **hello-auth-keychain** configuration will be applied and the **hello-authentication-key** command will be ignored.

The **no** form of the command removes the hello authentication key from the configuration.

## Default

no hello-authentication-key

## Parameters

### *authentication-key*

the authentication key can be any combination of ASCII characters up to 254 characters in length (unencrypted). If spaces are used in the string, the entire string must be enclosed within double quotes (" ").

### *hash-key*

the hash key can be any combination of ASCII characters up to 352 characters in length (encrypted) or 451 characters in length (if the **hash2** parameter is used). If spaces are used in the string, the entire string must be enclosed within double quotes (" ").

This is useful when a user must configure the parameter, but for security purposes, the actual unencrypted key value is not provided.

### **hash**

specifies that the key is entered in an encrypted form. If the **hash** parameter is not used, the key is assumed to be in a non-encrypted, clear text form. For security, all keys are stored in encrypted form in the configuration file with the **hash** parameter specified.

### **hash2**

specifies that the key is entered in a more complex encrypted form. If the **hash2** parameter is not used, the less encrypted hash form is assumed.

## hello-authentication-type

## Syntax

**hello-authentication-type** {password | message-digest}

**no hello-authentication-type**

## Context

config>router>isis>interface

config>router>isis>interface>level

## Description

This command enables Hello authentication at either the interface or level context. Both the hello authentication key and the hello authentication type on a segment must match. The [hello-auth-keychain](#) command must also be entered.

To configure the hello authentication type for all levels configured for the interface, use the **hello-authentication-type** command in the **config>router>isis>interface** context.

To configure or override the hello authentication type for a specific level, use the **hello-authentication-type** command in the **config>router>isis>interface>level** context.

The **no** form of the command disables Hello PDU authentication.

## Default

no hello-authentication-type

## Parameters

### password

enables simple password (plaintext) authentication. If authentication is enabled and no authentication type is specified in the command, simple password authentication is enabled.

### message-digest

enables message-digest MD5 authentication in accordance with RFC 1321. If this option is configured, at least one message-digest-key must be configured.

## hello-interval

## Syntax

**hello-interval** *seconds*

**no hello-interval**

## Context

config>router>isis>interface>level

## Description

This command configures the interval between IS-IS Hello PDUs issued on the interface at this level. The **hello-interval**, along with the **hello-multiplier**, is used to calculate a hold time, which is communicated to a neighbor in a Hello PDU.



**Note:** The neighbor hold time is (hello multiplier × hello interval) on non-designated intermediate system broadcast interfaces and point-to-point interfaces and is (hello multiplier × hello interval / 3) on designated intermediate system broadcast interfaces. Hello values can be adjusted for faster convergence, but the hold time should always be > 3 to reduce routing instability.

The **no** form of this command reverts to the default value.

## Default

3 – for designated intermediate system interfaces

9 – for non-designated intermediate system interfaces and point-to-point interfaces

## Parameters

*seconds*

the hello interval, in seconds, expressed as a decimal integer

**Values** 1 to 20000

## hello-multiplier

### Syntax

**hello-multiplier** *multiplier*

**no hello-multiplier**

### Context

config>router>isis>interface>level

### Description

This command configures a hello multiplier. The **hello-multiplier**, along with the **hello-interval**, is used to calculate a hold time, which is communicated to a neighbor in a Hello PDU.

The hold time is the time in which the neighbor expects to receive the next Hello PDU. If the neighbor receives a Hello within this time, the hold time is reset. If the neighbor does not receive a Hello within the hold time, it brings the adjacency down.



**Note:** The neighbor hold time is (hello multiplier × hello interval) on non-designated intermediate system broadcast interfaces and point-to-point interfaces and is (hello multiplier × hello interval / 3) on designated intermediate system broadcast interfaces. Hello values can be adjusted for faster convergence, but the hold time should always be > 3 to reduce routing instability.

The **no** form of this command reverts to the default value.

### Default

3

### Parameters

*multiplier*

the multiplier for the hello interval, in seconds, expressed as a decimal integer

**Values** 2 to 100

## interface-type

### Syntax

**interface-type** {**broadcast** | **point-to-point**}

**no interface-type**

### Context

config>router>isis>interface

### Description

This command configures the interface type to be either broadcast or point-to-point.

Use this command to set the interface type of an Ethernet link to point-to-point to avoid having to carry the broadcast adjacency maintenance overhead of the Ethernet link, provided the link is used as a point-to-point link.

If the interface type is not known when the interface is added to IS-IS, and the IP interface is subsequently bound (or moved) to a different interface type, this command must be entered manually.

The **no** form of the command reverts to the default value.

## Default

broadcast – if the physical interface is Ethernet or unknown

point-to-point – if the physical interface is T1, E1, or SONET/SDH

## Parameters

### broadcast

configures the interface to maintain this link as a broadcast network. To significantly improve adjacency forming and network convergence, a network should be configured as point-to-point if only two routers are connected, even if the network is a broadcast media such as Ethernet.

### point-to-point

configures the interface to maintain this link as a point-to-point link

## ipv4-adjacency-sid

## Syntax

**ipv4-adjacency-sid** *label value*

**no ipv4-adjacency-sid**

## Context

config>router>isis>interface

## Description

This command assigns a static value to an IPv4 adjacency SID in IS-IS segment routing.

The **no** form of the command removes the adjacency SID.

## Default

no ipv4-adjacency-sid

## Parameters

*value*

the static value of the adjacency SID

**Values** 1 to 1048575 within the segment routing local block (SRLB) range

## ipv4-multicast-disable

### Syntax

**[no] ipv4-multicast-disable**

### Context

config>router>isis>interface

### Description

This command disables IS-IS IPv4 multicast routing for the interface.

The **no** form of the command enables IS-IS IPv4 multicast routing for the interface.

### Default

no ipv4-multicast-disable

## ipv4-multicast-metric

### Syntax

**ipv4-multicast-metric** *ipv4-multicast-metric*

**no ipv4-multicast-metric**

### Context

config>router>isis>interface>level

### Description

This command configures the metric to be used for the IS-IS interface in the IPv4 multicast routing topology (MT 3).

The **no** form of the command returns the setting to the default value. This may be either the system default or the default metric for the associated topology if one is configured.

### Default

10

### Parameters

*ipv4-multicast-metric*

specifies the metric to be used for the associated interface in the SPF calculation for the IPv4 multicast routing topology (MT 3)

**Values** 1 to 16777215

## ipv4-node-sid

### Syntax

**ipv4-node-sid index** *index-value*

**ipv4-node-sid label** *label-value*

**no ipv4-node-sid**

### Context

config>router>isis>interface

### Description

This command assigns a node SID index or label value to the prefix representing the primary address of an IPv4 network interface of **type loopback**. Only a single node SID can be assigned to an interface. The secondary address of an IPv4 interface cannot be assigned a node SID index and does not inherit the SID of the primary IPv4 address.

This command fails if the network interface is not of **type loopback** or if the interface is defined in an IES or a VPRN context.

Assigning the same SID index or label value to the same interface in two different IGP instances is not allowed within the same node.

The value of the label or index SID is taken from the range configured for this IGP instance. When using the global mode of operation, the segment routing module checks that the same index or label value is not assigned to more than one loopback interface address. When using the per-instance mode of operation, this check is not required because the index, and therefore the label ranges, of IGP instances are not allowed to overlap.

### Default

no ipv4-node-sid

### Parameters

*index-value*

specifies the index value

**Values** 0 to 4294967295

*label-value*

specifies the label value

**Values** 0 to 4294967295

## ipv6-adjacency-sid

### Syntax

**ipv6-adjacency-sid label** *value*

## no ipv6-adjacency-sid

### Context

```
config>router>isis>interface
```

### Description

This command assigns a static value to an IPv6 adjacency SID in IS-IS segment routing. The **no** form of the command removes the adjacency SID.

### Default

```
no ipv6-adjacency-sid
```

### Parameters

*value*

the static value of the adjacency SID

**Values** 1 to 1048575 within the segment routing label block (SRLB) range

## ipv6-multicast-disable

### Syntax

```
[no] ipv6-multicast-disable
```

### Context

```
config>router>isis>interface
```

### Description

This command disables IS-IS IPv6 multicast routing for the interface. The **no** form of the command enables IS-IS IPv6 multicast routing for the interface.

### Default

```
no ipv6-multicast-disable
```

## ipv6-multicast-metric

### Syntax

```
ipv6-multicast-metric ipv6-multicast-metric  
no ipv6-multicast-metric
```

### Context

```
config>router>isis>interface>level
```



## Description

This command configures the metric to be used for the IS-IS interface in the IPv6 multicast routing topology (MT 4).

The **no** form of the command returns the setting to the default value. This may be either the system default or the default metric for the associated topology if one is configured.

## Default

10

## Parameters

*ipv6-multicast-metric*

specifies the metric to be used for the associated interface in the SPF calculation for the IPv6 multicast routing topology (MT 4)

**Values** 1 to 16777215

## ipv6-node-sid

## Syntax

**ipv6-node-sid index** *index-value*

**ipv6-node-sid label** *label-value*

**no ipv6-node-sid**

## Context

config>router>isis>interface

## Description

This command assigns a node SID index or label value to the prefix representing the primary address of an IPv6 network interface of **type loopback**. Only a single node SID can be assigned to an IPv6 interface. When an IPv6 interface has multiple global addresses, the primary address is always the first one in the list, as displayed by the **interface info** command.

This command fails if the network interface is not of **type loopback** or if the interface is defined in an IES or a VPRN context.

Assigning the same SID index or label value to the same interface in two different IGP instances is not allowed within the same node.

The value of the label or index SID is taken from the range configured for this IGP instance. When using the global mode of operation, the segment routing module checks that the same index or label value is not assigned to more than one loopback interface address. When using the per-instance mode of operation, this check is not required because the index, and therefore the label ranges, of IGP instances are not allowed to overlap.

## Default

no ipv6-node-sid

## Parameters

*index-value*

specifies the index value

**Values** 0 to 4294967295

*label-value*

specifies the label value

**Values** 0 to 4294967295

## ipv6-unicast-disable

### Syntax

**[no] ipv6-unicast-disable**

### Context

config>router>isis>interface

### Description

This command disables IS-IS IPv6 unicast routing for the interface.

By default, IPv6 unicast is enabled on all interfaces. However, IPv6 unicast routing in IS-IS is essentially in a multitopology when the **config>router>isis>ipv6-routing mt** command is configured.

The **no** form of the command enables IS-IS IPv6 unicast routing for the interface.

### Default

no ipv6-unicast-disable

## ipv6-unicast-metric

### Syntax

**ipv6-unicast-metric** *ipv6-metric*

**no ipv6-unicast-metric**

### Context

config>router>isis>interface>level

### Description

This command configures the metric to be used for the IS-IS interface in the IPv6 unicast routing topology (MT 2).

The **no** form of the command returns the setting to the default value. This may be either the system default or the default metric for the associated topology if one is configured.

**Default**

10

**Parameters***ipv6-metric*

specifies the metric to be used for the associated interface in the SPF calculation for the IPv6 unicast routing topology (MT 2)

**Values** 1 to 16777215

**lfa-policy-map****Syntax****lfa-policy-map route-nh-template** *template-name***no lfa-policy-map****Context**

config&gt;router&gt;isis&gt;interface

**Description**

This command applies a route next-hop policy template to an IS-IS interface. When a route next-hop policy template is applied to an interface in IS-IS, it is applied in both level 1 and level 2.

If the interface has been excluded from LFA with the [loopfree-alternate-exclude](#) command, the LFA policy has no effect on the interface.

If the route next-hop policy template is applied to a loopback interface or to the system interface, the command will not be rejected, but the policy will have no effect on the interface.

The **no** form of the command deletes the mapping of a route next-hop policy template to an IS-IS interface.

**Default**

no lfa-policy-map

**Parameters***template-name*

the name of an existing template

**lsp-pacing-interval****Syntax****lsp-pacing-interval** *milliseconds***no lsp-pacing-interval**

## Context

```
config>router>isis>interface
```

## Description

This command configures the interval between link-state PDUs (LSPs) sent from this interface. Controlling the time between LSPs ensures that adjacent neighbors are not being bombarded with excessive data.

A value of 0 means that no LSPs are sent from the interface.

The **no** form of the command reverts to the default value.

## Default

100

## Parameters

*milliseconds*

the interval that LSPs can be sent from the interface, expressed as a decimal integer

**Values** 0 to 65335

## mesh-group

## Syntax

```
mesh-group [value | blocked]
```

```
no mesh-group
```

## Context

```
config>router>isis>interface
```

## Description

This command assigns an interface to a mesh group. Mesh groups limit the amount of flooding that occurs when a new or changed LSP is advertised throughout an area.

All routers in a mesh group should be fully meshed. When LSPs need to be flooded, only a single copy is received rather than one copy per neighbor.

To create a mesh group, configure the same mesh group value for each interface that is part of the mesh group. All routers must have the same mesh group value configured for all interfaces that are part of the mesh group.

To prevent an interface from flooding LSPs, the optional **blocked** parameter can be specified.



**Caution:** Configure mesh groups carefully. It is easy to create isolated islands that will not receive updates if other links fail.

The **no** form of the command removes the interface from the mesh group.

**Default**

no mesh-group

**Parameters**

*value*

the unique decimal integer that distinguishes this mesh group from other mesh groups on this router or on other routers

**Values** 1 to 2000000000

**blocked**

prevents an interface from flooding LSPs

**metric****Syntax**

**metric** *metric*

**no metric**

**Context**

config>router>isis>interface>level

**Description**

This command configures the metric used for the level on this IS-IS interface.

To calculate the lowest cost to reach a given destination, each configured level on each interface must have a cost. The costs for each level on an interface may be different.

If the metric is not configured, the default value of 10 is used unless the [reference-bandwidth](#) is configured.

The **no** form of the command reverts to the default value.

**Default**

no metric (10)

**Parameters**

*metric*

the metric assigned to this level on this interface, expressed as a decimal integer

**Values** 1 to 16777215

## passive

### Syntax

[no] passive

### Context

config>router>isis>interface

config>router>isis>interface>level

### Description

This command adds the passive attribute to the IS-IS interface, which causes the interface to be advertised as an IS-IS interface without running the IS-IS protocol. Normally, only interface addresses that are configured for IS-IS are advertised as IS-IS interfaces at the level that they are configured.

If the passive mode is enabled, the interface or the interface at the specified level ignores ingress IS-IS protocol PDUs and will not transmit IS-IS protocol PDUs.

The **no** form of the command removes the passive attribute.

### Default

no passive

## priority

### Syntax

**priority** *number*

**no priority**

### Context

config>router>isis>interface>level

### Description

This command configures the priority of the IS-IS interface that is used in an election of the designated router (DIS) on a multi-access network.

This parameter is only used if the interface is a broadcast type.

The priority is included in Hello PDUs transmitted by the interface on a multi-access network. The router with the highest priority becomes the designated router. The designated router is responsible for sending LSPs about the network and the routers attached to it.

The **no** form of the command reverts to the default value.

### Default

64

## Parameters

*number*

the priority for this interface at this level, expressed as a decimal integer

**Values** 0 to 127

## retransmit-interval

### Syntax

**retransmit-interval** *seconds*

**no retransmit-interval**

### Context

config>router>isis>interface

### Description

This command specifies the interval, in seconds, that IS-IS will wait before retransmitting an unacknowledged LSP to an IS-IS neighbor.

If the retransmit interval expires and no acknowledgment has been received, the LSP will be retransmitted.

The **no** form of this command reverts to the default interval.

### Default

5

## Parameters

*seconds*

the retransmit interval, in seconds, expressed as a decimal integer

**Values** 1 to 65335

## sid-protection

### Syntax

**[no] sid-protection**

### Context

config>router>isis>interface

### Description

This command enables or disables adjacency SID protection by LFA and remote LFA.

LFA and remote LFA fast reroute (FRR) protection is enabled for all node SIDs and local adjacency SIDs when the user enables the **loopfree-alternate** option in IS-IS or OSPF at the LER and LSR. However,

there may be applications where the user never wants traffic to divert from the strict hop computed by CSPF for an SR-TE LSP. In this case, the user can disable protection for all adjacency SIDs formed over a particular network IP interface using this command.

The protection state of an adjacency SID is advertised in the B flag of the IS-IS or OSPF Adjacency SID sub-TLV.

## Default

sid-protection

## 5.11.2.2 Show commands



**Note:** The following command outputs are examples only; actual displays may differ depending on supported functionality and user configuration.

isis

### Syntax

**isis all**

**isis** [*isis-instance*]

### Context

show>router

### Description

This command enables the context to display IS-IS information.

### Parameters

**all**

enables the context to display all IS-IS instances

*isis-instance*

enables the context to display the specified IS-IS instance ID. If no *isis-instance* is specified, instance 0 is used.

**Values** 0 to 31

adjacency

### Syntax

**adjacency** [*ip-int-name* | *ip-address* | *nbr-system-id*] [**detail**]

### Context

show>router>isis



## Description

This command displays information about IS-IS neighbors. If no parameters are specified, adjacencies for the specified IS-IS instance are displayed. If **detail** is specified, operational and statistical information is displayed.

To display adjacency information for all IS-IS instances, use the **show router isis all** context.

## Parameters

*ip-int-name*

displays only adjacencies with the specified interface

*ip-address*

displays only adjacencies with the specified IPv4 or IPv6 address

*nbr-system-id*

displays only the adjacency with the specified system ID

**Values** 6-octet system identifier (xxxx.xxxx.xxxx)

**detail**

displays detailed information about the adjacency

## Output

The following output is an example of IS-IS adjacency information, and [Table 67: Adjacency field descriptions](#) describes the fields for both summary and detailed outputs.

### Output example

```
A:ALU-A# show router isis adjacency
=====
Rtr Base ISIS Instance 0 Adjacency
=====
System ID          Usage  State Hold Interface          MT-ID
-----
ALU-B              L1    Up    2    ip-to1                    0
ALU-B              L2    Up    2    ip-to2                    0
ALU-F              L1L2  Up    5    ip-303                    0
-----
Adjacencies : 3
=====
A:ALU-A#
```

```
*A:Sar18 Dut-B>show>router# isis all adjacency
=====
Rtr Base ISIS Instance 0 Adjacency
=====
System ID          Usage State Hold Interface          MT-ID
-----
ALU-B              L1    Up    2    ip-to1                    0
ALU-B              L2    Up    2    ip-to2                    0
ALU-F              L1L2  Up    5    ip-303                    0
=====
Rtr Base ISIS Instance 1 Adjacency
=====
System ID          Usage State Hold Interface          MT-ID
-----
```

```

No Matching Entries
=====
Rtr Base ISIS Instance 2 Adjacency
=====
System ID           Usage State Hold Interface           MT-ID
-----
No Matching Entries
=====
    
```

Table 67: Adjacency field descriptions

Label	Description
System ID	System ID of the neighbor
Usage/L. Circ Typ	Level on the interface: L1, L2, or L1/2
State	State of the adjacency: up, down, new, one-way, initializing, or rejected
Hold/Hold Time	Hold time remaining for the adjacency
Interface	Interface name associated with the neighbor
MT-ID	The multitopology ID number. The value can be 0, 2, 3, or 4. More than one ID is shown when more than one adjacency is established. An adjacency can be established per topology.

## capabilities

### Syntax

**capabilities** [*system-id* | *lsp-id*] [**level** *level* ]

### Context

show>router>isis

### Description

This command displays information about the capabilities for the specified IS-IS instance. If no parameters are specified, capabilities for the specified IS-IS instance are displayed. If **level** is specified, only information for the configured level is displayed.

To display capabilities information for all IS-IS instances, use the **show router isis all** context.

### Parameters

*system-id*

displays only the LSPs related to the specified system ID

*lsp-id*

displays only the specified LSP (hostname)

*level*

displays information only for the specified level (1 or 2)

## Output

The following output is an example of IS-IS capabilities information, and [Table 68: IS-IS capabilities field descriptions](#) describes the fields.

### Output example

```
*A:7705:Dut-A# show router isis capabilities
```

```
=====
Rtr Base ISIS Instance 0 Capabilities
=====
```

```
Displaying Level 1 capabilities
-----
```

```
LSP ID   : 7705:Dut-A.00-00
  Router Cap : 10.20.1.1, D:0, S:0
    TE Node Cap : B E M
    SR Cap: IPv4 MPLS-IPv6
      SRGB Base:20000, Range:10001
    SR Alg: metric based SPF
LSP ID   : 7705:Dut-A.01-00
LSP ID   : 7705:Dut-A.02-00
LSP ID   : 7705:Dut-C.00-00
  Router Cap : 10.20.1.3, D:0, S:0
    TE Node Cap : B E M
    SR Cap: IPv4 MPLS-IPv6
      SRGB Base:20000, Range:10001
    SR Alg: metric based SPF
LSP ID   : 7705:Dut-C.02-00
LSP ID   : 7705:Dut-C.03-00
LSP ID   : 7705:Dut-D.00-00
  Router Cap : 10.20.1.4, D:0, S:0
    TE Node Cap : B E M
    SR Cap: IPv4 MPLS-IPv6
      SRGB Base:20000, Range:10001
    SR Alg: metric based SPF
LSP ID   : 7705:Dut-B.00-00
  Router Cap : 10.20.1.22, D:0, S:0
    TE Node Cap : B E M
    SR Cap: IPv4 MPLS-IPv6
      SRGB Base:20000, Range:10001
    SR Alg: metric based SPF
LSP ID   : 7705:Dut-B.01-00
Level (1) Capability Count : 9
```

```
Displaying Level 2 capabilities
-----
```

```
LSP ID   : 7705:Dut-A.00-00
  Router Cap : 10.20.1.1, D:0, S:0
    TE Node Cap : B E M
    SR Cap: IPv4 MPLS-IPv6
      SRGB Base:20000, Range:10001
    SR Alg: metric based SPF
LSP ID   : 7705:Dut-A.01-00
LSP ID   : 7705:Dut-A.02-00
LSP ID   : 7705:Dut-C.00-00
  Router Cap : 10.20.1.3, D:0, S:0
    TE Node Cap : B E M
    SR Cap: IPv4 MPLS-IPv6
      SRGB Base:20000, Range:10001
```

```

SR Alg: metric based SPF
LSP ID   : 7705:Dut-C.02-00
LSP ID   : 7705:Dut-C.03-00
LSP ID   : 7705:Dut-D.00-00
Router Cap : 10.20.1.4, D:0, S:0
TE Node Cap : B E M
SR Cap: IPv4 MPLS-IPv6
SRGB Base:20000, Range:10001
SR Alg: metric based SPF
LSP ID   : 7705:Dut-B.00-00
Router Cap : 10.20.1.22, D:0, S:0
TE Node Cap : B E M
SR Cap: IPv4 MPLS-IPv6
SRGB Base:20000, Range:10001
SR Alg: metric based SPF
LSP ID   : 7705:Dut-B.01-00
Level (2) Capability Count : 9
=====
    
```

Table 68: IS-IS capabilities field descriptions

Label	Description
LSP ID	The LSP ID of the specified system ID or hostname
Router Cap	The router IP address and capability
TE Node Cap	The TE node capability
SR Cap	The segment routing capability
SRGB Base	The Segment Routing Global Block (SRGB) base index value and range
SR Alg	The type of SR algorithm used for the specified LSP ID
Level (n) Capability Count	The capability count for the specified level

## database

### Syntax

**database** [*system-id* | *lsp-id*] [**detail**] [**level** *level*]

### Context

show>router>isis

### Description

This command displays information about the IS-IS link-state database. If the system ID and LSP ID are not specified, database entries for the specified IS-IS instance are listed.

To display database information for all IS-IS instances, use the **show router isis all** context.

**Parameters**

*system-id*

displays only the LSPs related to the specified system ID

*lsp-id*

displays only the specified LSP (hostname)

**detail**

displays detailed information for the link-state database entries

*level*

displays information only for the specified level (1 or 2)

**Output**

The following outputs are examples of IS-IS database information:

- IS-IS summary database information ([Output example](#), [Table 69: Database summary field descriptions](#))
- IS-IS detailed database information ([Output example](#), [Table 70: Database detailed field descriptions](#))

**Output example**

```
A:ALU-A# show router isis database
=====
Rtr Base ISIS Instance 0 Database
=====
LSP ID                               Sequence Checksum Lifetime Attributes
-----
Displaying Level 1 database
-----
ALU-A.00-00                           0x7      0x51b4   1177   L1L2
Level (1) LSP Count : 1

Displaying Level 2 database
-----
ALU-A.00-00                           0x7      0x51b4   1014   L1L2
Level (2) LSP Count : 1
=====
A:ALU-A#
```

*Table 69: Database summary field descriptions*

Label	Description
LSP ID	<p>LSP IDs are auto-assigned by the originating IS-IS node. The LSP ID consists of three sections: the first 6 bytes are the system ID for that node, followed by a single byte value for the pseudonode generated by that router, followed by a fragment byte that starts at 0.</p> <p>For example, if a router’s system ID is 1800.0000.0029, the first LSP ID is 1800.0000.0029.00-00. If there are too many routes, LSP ID 1800.0000.0029.00-01 is created to contain the excess routes. If the router is the designated router (or designated intermediate system ([DIS]) on a broadcast network, a pseudonode LSP is created. Usually the internal circuit ID</p>

Label	Description
	is used to determine the ID assigned to the pseudonode. For instance, for circuit 4, an LSP pseudonode with ID 1800.0000.0029.04-00 is created.  Note: The 7705 SAR learns hostnames and uses the hostname in place of the system ID.
Sequence	The sequence number of the LSP that allows other systems to determine if they have received the latest information from the source
Checksum	The checksum of the entire LSP packet
Lifetime	Length of time, in seconds, that the LSP remains valid
Attributes	OV: the overload bit is set
	L1: specifies a level 1 router
	L2: specifies a level 2 router
	L1L2: specifies a level 1/2 router
	ATT: the attachment bit is set; when set, the router can act as a level 2 router and can reach other areas

**Output example**

```
*A:ALU-A# show router isis database detail
=====
Rtr Base ISIS Instance 0 Database (detail)
=====

Displaying Level 1 database
-----
LSP ID   : ALU-A.00-00          Level   : L1
Sequence : 0x7                  Checksum : 0x51b4   Lifetime : 1079
Version  : 1                    Pkt Type : 18      Pkt Ver  : 1
Attributes: L1L2                Max Area : 3       Alloc Len : 1492
SYS ID   : 0100.1001.0001      SysID Len : 6      Used Len  : 50

TLVs :
  Supp Protocols:
    Protocols   : IPv4
  IS-Hostname  : ALU-A
  Router ID    :
  Router ID    : 10.0.0.0

Level (1) LSP Count : 1

Displaying Level 2 database
-----
LSP ID   : ALU-A.00-00          Level   : L2
Sequence : 0x7                  Checksum : 0x51b7   Lifetime : 900
Version  : 1                    Pkt Type : 20      Pkt Ver  : 1
Attributes: L1L2                Max Area : 3       Alloc Len : 1492
SYS ID   : 0100.1001.0001      SysID Len : 6      Used Len  : 50
```

```

TLVs :
  Supp Protocols:
    Protocols      : IPv4
  IS-Hostname     : ALU-A
  Router ID      :
    Router ID     : 10.0.0.0

Level (2) LSP Count : 1
    
```

Table 70: Database detailed field descriptions

Label	Description
LSP ID	<p>LSP IDs are auto-assigned by the originating IS-IS node. The LSP ID consists of three sections: the first 6 bytes are the system ID for that node, followed by a single byte value for the pseudonode generated by that router, followed by a fragment byte that starts at 0.</p> <p>For example, if a router's system ID is 1800.0000.0029, the first LSP ID is 1800.0000.0029.00-00. If there are too many routes, LSP ID 1800.0000.0029.00-01 is created to contain the excess routes. If the router is the designated router (or designated intermediate system ([DIS]) on a broadcast network, a pseudonode LSP is created. Usually the internal circuit ID is used to determine the ID assigned to the pseudonode. For instance, for circuit 4, an LSP pseudonode with ID 1800.0000.0029.04-00 is created.</p> <p>The 7705 SAR learns hostnames and uses the hostname in place of the system ID.</p>
Sequence	The sequence number of the LSP that allows other systems to determine if they have received the latest information from the source
Checksum	The checksum of the entire LSP packet
Lifetime	Length of time, in seconds, that the LSP remains valid
Attributes	OV: the overload bit is set
	L1: specifies a level 1 router
	L2: specifies a level 2 router
	L1L2: specifies a level 1/2 router
	ATT: the attachment bit is set; when set, the router can act as a level 2 router and can reach other areas
LSP Count	A sum of all the configured level 1 and level 2 LSPs

Label	Description
LSP ID	A unique identifier for each LSP, consisting of the system ID, pseudonode ID, and LSP name
Version	The version protocol ID extension – always set to 1
Pkt Type	The PDU type number
PkT Ver	The version protocol ID extension – always set to 1
Max Area	The maximum number of area addresses supported
Alloc Len	The amount of memory space allocated for the LSP
SYS ID	The system ID
SysID Len	The length of the system ID field (0 or 6)
Used Len	The actual length of the PDU
Area Address	The area addresses to which the router is connected
Supp Protocols	The supported data protocols
IS-Hostname	The name of the router from which the LSP originated
Virtual Flag	0: level 1 routers report this octet as 0 to all neighbors
	1: indicates that the path to a neighbor is a level 2 virtual path used to repair an area partition
Neighbor	The routers running interfaces to which the router is connected
Internal Reach	A 32-bit metric
	A bit is added for the up/down transitions resulting from level 2 to level 1 route leaking
IP Prefix	The IP addresses that the router knows about by externally originated interfaces
Metrics	The routing metric used in the IS-IS link-state calculations

## hostname

### Syntax

**hostname**

### Context

show>router>isis



## Description

This command displays the hostname database for the specified IS-IS instance.

To display hostname information for all IS-IS instances, use the **show router isis all** context.

## Output

The following output is an example of hostname database information, and [Table 71: Hostname database field descriptions](#) describes the fields.

### Output example

```
*A:ALU-A show router isis hostname
=====
Rtr Base ISIS Instance 0 Hostnames
=====
System Id           Hostname
-----
2550.0000.0000      7705_custDoc
-----
Hostnames : 1
=====
```

Table 71: Hostname database field descriptions

Label	Description
System ID	The system ID mapped to the hostname
Hostname	The hostname for the specified system ID

## interface

### Syntax

```
interface [ip-int-name | ip-address] [detail]
```

### Context

```
show>router>isis
```

### Description

This command displays the details of the IS-IS interface, which can be identified by IP address or IP interface name. If neither is specified, in-service interfaces for the specified IS-IS instance are displayed.

To display interface information for all IS-IS instances, use the **show router isis all** context.

### Parameters

*ip-int-name*

displays only the interface identified by this interface name

*ip-address*

displays only the interface identified by this IP address

**detail**

displays detailed information for the interface

**Output**

The following outputs are examples of IS-IS interface information:

- IS-IS summary interface information ( [Output example](#), [Table 72: Interface field descriptions](#) )
- IS-IS detailed interface information ( [Output example](#), [Table 73: Interface detailed field descriptions](#) )

**Output example**

```
A:ALU-A# show router isis interface
=====
Rtr Base ISIS Instance 0 Interfaces
=====
Interface                Level CircID  Oper State  L1/L2 Metric
-----
system                   L1L2   1          Up          0/0
isis_interface           L1L2  30         Down        10/10
-----
Interfaces : 2
=====
A:ALU-A#
```

*Table 72: Interface field descriptions*

Label	Description
Interface	The interface name
Level	The interface level: L1, L2, or L1L2
CircID	The circuit identifier
Oper State	Up: the interface is operationally up
	Down: the interface is operationally down
L1/L2 Metric	Interface metric for level 1 and level 2, if none are set to 0

**Output example**

```
A:ALU-A# show router isis interface isis_interface detail
=====
Rtr Base ISIS Instance 0 Interfaces
=====
Interface      : isis_interface          Level Capability: L1L2
Oper State    : Down                    Admin State      : Up
Auth Type     : None
Circuit Id    : 30                      Retransmit Int. : 5
Type          : Broadcast                LSP Pacing Int. : 100
Mesh Group    : Inactive                 CSNP Int.       : 10
LFA NH Template: None                   Bfd Enabled     : No
Topology      : IPv4-Unicast, IPv6-Unicast
Te Metric     : 0                       Te State        : Down
Admin Groups  : None
```

```

Ldp Sync      : outOfService          Ldp Sync Wait : Disabled
Ldp Timer State: Disabled             Ldp Tm Left   : 0
Route Tag     : None                  LFA           : Included

Level        : 1                      Adjacencies   : 0
Auth Type    : None                   Metric        : 0
Hello Timer  : 9                      IPv6-Ucast-Met : 0
Priority     : 64
Passive      : No
SD-Offset   : 0                      SF-Offset     : 0
Hello Mult.  : 3

Level        : 2                      Adjacencies   : 0
Auth Type    : None                   Metric        : 0
Hello Timer  : 9                      IPv6-Ucast-Met : 0
Priority     : 64
Passive      : No
SD-Offset   : 0                      SF-Offset     : 0
Hello Mult.  : 3

=====
A:ALU-A#
    
```

Table 73: Interface detailed field descriptions

Label	Description
Interface	The interface name
Level Capability	The routing level for the IS-IS routing process
Oper State	Up: the interface is operationally up
	Down: the interface is operationally down
Admin State	Up: the interface is administratively up
	Down: the interface is administratively down
Auth Type	The authentication type for the interface
Circuit Id	The circuit identifier
Retransmit Int.	The length of time, in seconds, that IS-IS will wait before retransmitting an unacknowledged LSP to an IS-IS neighbor
Type	The interface type: point-to-point or broadcast
LSP Pacing Int.	The interval between LSPs sent from this interface
Mesh Group	Indicates whether a mesh group has been configured
CSNP Int.	The time, in seconds, that complete sequence number PDUs (CSNPs) are sent from the interface
LFA NH Template	Indicates whether an LFA next-hop policy template is applied to this interface

Label	Description
BFD Enabled	Indicates whether BFD is enabled or disabled
Topology	The network topologies enabled on the interface
TE Metric	The TE metric configured for this interface. This metric is flooded out in the TE metric sub-TLV in the IS-IS-TE LSPs. Depending on the configuration, either the TE metric value or the native IS-IS metric value is used in CSPF computations.
TE State	The MPLS interface TE status from the IS-IS standpoint
Admin Groups	The bitmap inherited from the MPLS interface that identifies the admin groups to which this interface belongs
Ldp Sync	Specifies whether the IGP-LDP synchronization feature is enabled or disabled on all interfaces participating in the IS-IS routing protocol
Ldp Sync Wait	The time to wait for the LDP adjacency to come up
Ldp Timer State	The state of the LDP sync time left on the IS-IS interface
LDP TM Left	The time left before IS-IS reverts back to advertising normal metrics for this interface
Route Tag	The route tag for this interface
LFA	Indicates whether the interface is included in the LFA SPF calculation
Level	The interface level
Adjacencies	The number of adjacencies for this interface
Auth Type	The authentication type for the interface level
Metric	Indicates whether a metric has been configured for the interface level
Hello Timer	The interval between IS-IS Hello PDUs issued on the interface at this level
IPv6-Ucast-Met	Not applicable
Priority	The priority of the IS-IS interface that is used in an election of the designated router on a multi-access network
Passive	Indicates if passive mode is enabled or disabled; if enabled, the interface is advertised as an IS-IS interface without running the IS-IS protocol
SD-offset	Not applicable

Label	Description
SF-offset	Not applicable
Hello Mult.	Not applicable

## lfa-coverage

### Syntax

**lfa-coverage**

### Context

show>router>isis

### Description

This command displays IS-IS LFA coverage information for the specified IS-IS instance.

To display LFA coverage information for all IS-IS instances, use the **show router isis all** context.

### Output

The following output is an example of LFA coverage information, and [Table 74: LFA coverage field descriptions](#) describes the fields.

### Output example

```
A:ALU-A# show router isis lfa-coverage
=====
Rtr Base ISIS Instance 0 LFA Coverage
=====
Topology          Level   Node           IPv4            IPv6
-----
IPV4 Unicast      L1      0/0(0%)        0/0(0%)        0/0(0%)
IPV6 Unicast      L1      0/0(0%)        0/0(0%)        0/0(0%)
IPV4 Multicast    L1      0/0(0%)        0/0(0%)        0/0(0%)
IPV6 Multicast    L1      0/0(0%)        0/0(0%)        0/0(0%)
IPV4 Unicast      L2      0/0(0%)        0/0(0%)        0/0(0%)
IPV6 Unicast      L2      0/0(0%)        0/0(0%)        0/0(0%)
IPV4 Multicast    L2      0/0(0%)        0/0(0%)        0/0(0%)
IPV6 Multicast    L2      0/0(0%)        0/0(0%)        0/0(0%)
=====
A:ALU-A#
```

Table 74: LFA coverage field descriptions

Label	Description
Topology	The type of network
Level	The IS-IS level in which LFA is enabled
Node	The number of nodes in the level on which LFA is enabled

Label	Description
IPv4	The number of IPv4 interfaces on the nodes on which LFA is enabled
IPv6	The number of IPv6 interfaces on the nodes on which LFA is enabled

## mapping-server

### Syntax

**mapping-server** [**prefix** *ip-address* [/*mask*]] [**index** *index*] [**level** *level*] [**flag** {*s*}]

### Context

show>router>isis

### Description

This command displays IS-IS mapping server information.

### Parameters

*ip-address* [/*mask*]

specifies the IP address and subnet mask of a prefix that has received a node-sid in a SID/Label Binding TLV

**Values** ip-address: a.b.c.d. (host bits must be 0)  
mask: 0 to 32

*index*

specifies the node SID index value for the generated SID/Label Binding TLV

**Values** 0 to 4294967295

*level*

specifies a match on the mapping server's flooding scope for the generated SID/Label Binding TLV

**Values** 1, 2, 1/2

**flag s**

specifies a match on the flooding scope of the generated SID/Label Binding TLV that applies to the entire domain

### Output

The following output is an example of mapping server information.

### Output example

```
*A:Dut-C# show router isis mapping-server
```

```

=====
Rtr Base ISIS Instance 0 Mapping Server
=====
Index      Prefix          Range Flags Level
-----
1000      10.20.1.4/32    1   -   L1L2
1001      10.20.1.5/32    1   -   L1L2
1002      10.20.1.6/32    1   -   L1L2
-----
No. of Mapping Server Sid-Maps : 3
=====

```

## prefix-sids

### Syntax

**prefix-sids** [**ipv4-unicast** | **ipv6-unicast** | **mt** *mt-id-number*] [*ip-prefix/prefix-length*] [**sid** *sid*] [**adv-router** {*system-id* | *hostname*}] [**srms** | **no-srms**]

### Context

show>router>isis

### Description

This command displays IS-IS prefix SID information for the specified IS-IS instance.

To display prefix SID information for all IS-IS instances, use the **show router isis all** context.

### Parameters

#### **ipv4-unicast**

displays information for the IPv4 unicast prefix SIDs

#### **ipv6-unicast**

displays information for the IPv6 unicast prefix SIDs

#### *mt-id-number*

displays information for the specified multitopology ID number for the prefix SID

#### *ip-prefix/prefix-length*

IPv4 or IPv6 prefix and prefix length

#### *sid*

displays information related to the specified segment routing ID

**Values** 0 to 524287

#### *system-id*

displays only the prefix SIDs related to the specified system ID

#### *hostname*

displays only the prefix SIDs related to the specified host

**srms | no-srms**

displays information for the IPv4 unicast prefix SIDs segment routing mapping service (SRMS)

**Output**

The following output is an example of prefix SIDs information, and [Table 75: Prefix SIDs field descriptions](#) describes the fields.

**Output example**

```
*A:7705:Dut-A# show router isis prefix-sids
=====
Rtr Base ISIS Instance 0 Prefix/SID Table
=====
Prefix                SID          Lvl/Typ    SRMS    AdvRtr
                   MT          Flags
-----
10.20.1.1/32          2001        1/Int.     N       7705:Dut-A
                   0          NnP
10.20.1.1/32          2001        2/Int.     N       7705:Dut-A
                   0          NnP
10.20.1.3/32          2003        1/Int.     N       7705:Dut-C
                   0          NnP
10.20.1.3/32          2003        2/Int.     N       7705:Dut-C
                   0          NnP
10.20.1.4/32          2004        1/Int.     N       7705:Dut-D
                   0          NnP
10.20.1.4/32          2004        2/Int.     N       7705:Dut-D
                   0          NnP
10.20.1.22/32         2002        1/Int.     N       7705:Dut-B
                   0          NnP
10.20.1.22/32         2002        2/Int.     N       7705:Dut-B
                   0          NnP
-----
No. of Prefix/SIDs: 8 (4 unique)
-----
SRMS : Y/N = prefix SID advertised by SR Mapping Server (Y) or not (N)
      S    = SRMS prefix SID is selected to be programmed
Flags: R    = Re-advertisement
      N    = Node-SID
      nP   = no penultimate hop POP
      E    = Explicit-Null
      V    = Prefix-SID carries a value
      L    = value/index has local significance
=====
*A:7705:Dut-A#
```

*Table 75: Prefix SIDs field descriptions*

Label	Description
Prefix	The IP prefix for the SID
SID	The segment routing identifier (SID)
Lvl/Typ	The level and type of SR



Label	Description
SRMS	Indicates whether the prefix SID is advertised by the SR mapping service: Y (yes) or N (no)
MT	The multitopology ID number
AdvRtr	The advertised router name
Flags	The flags related to the advertised router: R = Re-advertisement N = Node-SID nP = No penultimate hop POP E = Explicit-Null V = Prefix-SID carries a value L = value/index has local significance

## routes

### Syntax

**routes** [**ipv4-multicast** | **ipv6-multicast** | **ipv4-unicast** | **ipv6-unicast** | **mt** *mt-id-number*] [*ip-prefix* [*prefix-length*]] [**alternative**] [**exclude-shortcut**] [**detail**]

### Context

show>router>isis

### Description

This command displays the routes in the IS-IS routing table for the specified IS-IS instance.

To display route information for all IS-IS instances, use the **show router isis all** context.

### Parameters

#### **ipv4-multicast**

displays IPv4 multicast parameters

#### **ipv4-unicast**

displays IPv4 unicast parameters

#### **ipv6-multicast**

displays IPv6 multicast parameters

#### **ipv6-unicast**

displays IPv6 unicast parameters

#### *mt-id-number*

displays information for the specified multitopology. The value can be 0, 2, 3, or 4.

*ip-prefix/prefix-length*

IPv4 or IPv6 prefix and prefix length

**alternative**

displays the level of protection per prefix

**exclude-shortcut**

displays routes without shortcuts

**detail**

displays detailed information for the route

**Output**

The following outputs are examples of IS-IS route information, and [Table 76: Routing table field descriptions](#) describes the fields.

**Output example**

```
A:ALU-A# show router isis routes
=====
Rtr Base ISIS Instance 0 Route Table
=====
Prefix [Flags]           Metric   Lvl/Typ  Ver.   SysID/Hostname
NextHop                  MT
-----
10.20.1.2/32             0        1/Int.   3      ALU-B
 10.0.0.0                 0
10.20.1.3/32 [L]       10        2/Int.   2      ALU-C
 10.20.3.3                 0
10.20.1.4/32            10        2/Int.   3      ALU-D
 10.20.4.4                 0
10.20.1.5/32            20        2/Int.   3      ALU-C
 10.20.3.3                 0
10.20.1.6/32            20        2/Int.   3      ALU-D
 10.20.4.4                 0
10.20.3.0/24            10        1/Int.   3      ALU-B
 10.0.0.0                 0
10.20.4.0/24            10        1/Int.   3      ALU-B
 10.0.0.0                 0
10.20.5.0/24            20        2/Int.   2      ALU-C
 10.20.3.3                 0
10.20.6.0/24            20        2/Int.   4      ALU-D
 10.20.4.4                 0
10.20.9.0/24            20        2/Int.   3      ALU-D
 10.20.4.4                 0
10.20.10.0/24           30        2/Int.   3      ALU-C
 10.20.3.3                 0
-----
No. of Routes : 11
Flags          : L = Loop-Free Alternate nexthop
Alt-Type       : LP = linkProtection, NP = nodeProtection
SID[F]        : R = Re-advertisement
                N = Node-SID
                nP = no penultimate hop POP
                E = Explicit-Null
                V = Prefix-SID carries a value
                L = value/index has local significance
=====
```

```

A:ALU-A#
A:ALU-A# show router isis routes alternative
=====
Rtr Base ISIS Instance 0 Route Table (alternative)
=====
Prefix [Flags]           Metric    Lvl/Typ  Ver.  SysID/Hostname
NextHop                 MT        AdminTag/SID[F]
Alt-NextHop             Alt-      Alt-Type
                        Metric
-----
10.10.1.0/24             10        1/Int.   3     ALU-A
10.0.0.0                 0         0
10.10.2.0/24             10        1/Int.   4     ALU-A
10.0.0.0                 0         0
10.10.4.0/24             20        1/Int.   5     ALU-B
10.10.1.2                0         0
10.10.5.0/24             20        1/Int.   5     ALU-C
10.10.2.3                0         0
10.10.9.0/24             30        1/Int.   6     ALU-B
10.10.1.2                0         0
10.20.1.5 (LFA) (LSP:RSVP:3) 50        nodeProtection
10.10.10.0/24            30        1/Int.   11    ALU-E
10.20.1.5 (LSP:RSVP:3)  0         0
10.20.1.1/32             0         1/Int.   1     ALU-A
10.0.0.0                 0         0
10.20.1.2/32             10        1/Int.   4     ALU-B
10.10.1.2                0         0
10.20.1.3/32             10        1/Int.   5     ALU-C
10.10.2.3                0         0
10.20.1.4/32             20        1/Int.   5     ALU-B
10.10.1.2                0         0
10.20.1.5 (LFA) (LSP:RSVP:3) 40        nodeProtection
10.20.1.5/32             20        1/Int.   11    Dut-E
10.20.1.5 (LSP:RSVP:3)  0         0
10.20.1.6/32             30        1/Int.   6     Dut-B_Sparrow
10.10.1.2                0         0
10.10.2.3 (LFA)          30        nodeProtection
-----
No. of Routes: 12
Flags      : L = Loop-Free Alternate nexthop
Alt-Type   : LP = linkProtection, NP = nodeProtection
SID[F]     : R = Re-advertisement
            N = Node-SID
            nP = no penultimate hop POP
            E = Explicit-Null
            V = Prefix-SID carries a value
            L = value/index has local significance
=====
A:ALU-A#
    
```

Table 76: Routing table field descriptions

Label	Description
Prefix (Flags)	The route prefix and mask, and the L/LFA flag (if applicable)
Metric	The metric of the route
Lvl/Typ	The level (1 or 2) and the route type (internal or external)

Label	Description
Ver.	The SPF version that generated the route
SysID/Hostname	The hostname for the specific system ID
MT	The multitopology ID number
NextHop	The system ID of the next hop (or the hostname, if possible)
AdminTag/SID[F]	The flags related to the SID: R = Re-advertisement N = Node SID nP = No penultimate hop POP E = Explicit null V = Prefix-SID carries a value L = Value/index has local significance
Alt-Nexthop	The backup next hop
Alt-Metric	The metric of the backup route
Alt-Type	The type of backup route LP = Link protection NP = Node protection

## spf-log

### Syntax

**spf-log [detail]**

### Context

show>router>isis

### Description

This command displays the last 20 SPF events for the specified IS-IS instance.

To display SPF log information for all IS-IS instances, use the **show router isis all** context.

### Parameters

#### detail

displays detailed information about the SPF events

## Output

The following output is an example of SPF events, and [Table 77: SPF log field descriptions](#) describes the fields.

### Output example

```
A:ALU-A# show router isis spf-log
=====
Rtr Base ISIS Instance 0 SPF Log
=====
When          Duration    L1 Nodes   L2 Nodes   Event Count  Type
-----
05/23/2018 18:41:06 <0.01s    1          1          1            Reg
05/23/2018 18:41:06 <0.01s    -          -          -            Lfa
-----
Log Entries: 2
=====
```

```
*A: Sar18 Dut-B>show>router# isis spf-log detail
=====
Rtr Base ISIS Instance 0 SPF Log
=====
When      : 05/23/2018 18:41:06          Duration   : <0.01s
L1 Nodes  : 1                          L2 Nodes  : 1
Trigger LSP: None                     Event Count : 1
SPF Type  : Reg
Reason    : LFACHANGED
When      : 05/23/2018 18:41:06          Duration   : <0.01s
L1 Nodes  : -                          L2 Nodes  : -
Trigger LSP: None                     Event Count : -
SPF Type  : Lfa
Reason    : LFACHANGED
=====
```

Table 77: SPF log field descriptions

Label	Description
When	The timestamp when the SPF run started on the system
Duration	The time (in hundredths of seconds) required to complete the SPF run
L1 Nodes	The number of level 1 nodes involved in the SPF run
L2 Nodes	The number of level 2 nodes involved in the SPF run
Trigger LSP	The LSP that triggered the SPF run
Event Count	The number of SPF events that triggered the SPF calculation
Type SPF Type	The SPF type: Reg (regular) or Lfa (Loopfree-Alternate)
Reason	The reasons for the SPF run: ADMINTAGCHANGED: An administrative tag changed

Label	Description
	DBCHANGED: The LSP database was cleared by an administrator ECMPCHANGED: An ECMP path changed LFACHANGED: The LFS changed LSPCONTENT: The content of an LSP changed LSPEXPIRED: An LSP expired MANUALREQ: An SPF calculation was requested by an administrator NEWADJ: An adjacency changed NEWAREA: An area changed NEWLSP: A new LSP was received NEWMETRIC: A prefix metric changed NEWNLPID: The routed protocols (IPv4 or IPv6) changed NEWPREF: The external route preference changed NEWREACH: A prefix changed RESTART: The graceful restart exited TUNNELCHANGED: An MPLS tunnel changed
Log Entries	The total number of log entries

## statistics

### Syntax

**statistics**

### Context

show>router>isis

### Description

This command displays information about IS-IS traffic statistics for the specified IS-IS instance.

To display statistics information for all IS-IS instances, use the **show router isis all** context.

### Output

The following output is an example of IS-IS statistical information, and [Table 78: IS-IS statistics field descriptions](#) describes the fields.

### Output example

```
A:ALU-A# show router isis statistics
=====
```

```

Rtr Base ISIS Instance 0 Statistics
=====
ISIS Instance      : 0
Purge Initiated    : 0
SID SRGB errors    : 0
LSP Regens.       : 39
SID dupl errors    : 0

CSPF Statistics
Requests          : 0
Paths Found       : 0
Request Drops     : 0
Paths Not Found   : 0

SPF Statistics
SPF Runs          : 1
Last scheduled    : 05/23/2018 18:41:05
Partial SPF Runs  : 3
Last scheduled    : 05/23/2018 18:41:03

LFA Statistics
LFA Runs          : 1
Last scheduled    : 05/23/2018 18:41:06
Partial LFA Runs  : 0

RLFA Statistics
RLFA Runs         : 0

TI-LFA Statistics
TI-LFA Runs       : 0

-----
PDU Type   Received   Processed   Dropped    Sent       Retransmitted
-----
LSP        0           0           0           0           0
IIH        0           0           0           0           0
CSNP       0           0           0           0           0
PSNP       0           0           0           0           0
Unknown    0           0           0           0           0
=====
A:ALU-A#
    
```

Table 78: IS-IS statistics field descriptions

Label	Description
ISIS Instance	The IS-IS instance
Purge Initiated	The number of times that purges have been initiated
LSP Regens	The number of LSP regenerations
SID SRGB errors	The number of SIDs received that are outside of the Segment Routing Global Block (SRGB) label range
SID dupl errors	The number of duplicate SIDs received from IS-IS nodes in the network
<b>CSPF Statistics</b>	
Requests	The number of CSPF requests made to the protocol
Request Drops	The number of CSPF requests dropped

Label	Description
Paths Found	The number of responses to CSPF requests for which paths satisfying the constraints were found
Paths Not Found	The number of responses to CSPF requests for which paths not satisfying the constraints were found
<b>SPF Statistics</b>	
SPF Runs	The number of times that SPF calculations have been made
Last scheduled	The timestamp of the last SPF run
Partial SPF Runs	The total number of partial SPF runs
Last scheduled	The timestamp of the last partial SPF run
<b>LFA Statistics</b>	
LFA Runs	The total number of incremental LFA SPF runs triggered by new or updated LSPs
Last scheduled	The timestamp of the last SPF run
Partial LFA Runs	The total number of partial LFA SPF runs triggered by new or updated LSPs
<b>RLFA Statistics</b>	
RLFA Runs	The total number of incremental remote LFA SPF runs triggered by new or updated LSPs
<b>TI-LFA Statistics</b>	
TI-LFA Runs	The total number of incremental topology-independent LFA SPF runs triggered by new or updated LSPs
<b>Other Statistics</b>	
PDU Type	The PDU (packet) type
Received	The number of LSPs received by this instance of the protocol
Processed	The number of LSPs processed by this instance of the protocol
Dropped	The number of LSPs dropped by this instance of the protocol
Sent	The number of LSPs sent out by this instance of the protocol
Retransmitted	The number of LSPs that had to be retransmitted by this instance of the protocol



## status

### Syntax

**status**

### Context

show>router>isis

### Description

This command displays the general status of IS-IS for the specified IS-IS instance.

To display statistics information for all IS-IS instances, use the **show router isis all** context.

### Output

The following output is an example of IS-IS status information, and [Table 79: IS-IS status field descriptions](#) describes the fields.

### Output example

```
*A: Sar18 Dut-B>show>router# isis status
=====
Rtr Base ISIS Instance 0 Status
=====
ISIS Oper System Id       : 2550.0000.0000
ISIS Cfg Router Id       : 0.0.0.0
ISIS Oper Router Id      : 255.0.0.0
ASN                       : 0
Admin State               : Up
Oper State                : Up
Ipv4 Routing              : Enabled
Ipv6 Routing              : Disabled
Last Enabled              : 03/01/2024 18:17:20
Level Capability          : L1L2
Authentication Check     : True
Auth Keychain             : Disabled
Authentication Type      : None
CSNP-Authentication      : Enabled
HELLO-Authentication     : Enabled
PSNP-Authentication     : Enabled
Traffic Engineering      : Disabled
Overload-On-Boot Timeout : 0
Overload Max-Metric      : False
Overload-On-Boot Max-Metric : False
LSP Lifetime             : 1200
LSP Wait (ms)            : 5000 (Max) 10 (Initial) 1000 (Second)
LSP MTU Size             : 1492 (Config)
L1 LSP MTU Size          : 1492 (Config) 1492 (Oper)
L2 LSP MTU Size          : 1492 (Config) 1492 (Oper)
Adjacency Check          : loose
L1 Auth Keychain         : Disabled
L1 Auth Type             : none
L1 CSNP-Authentication  : Enabled
L1 HELLO-Authentication : Enabled
L1 PSNP-Authentication  : Enabled
L1 Preference            : 15
L1 Ext. Preference       : 160
```

```

L1 Wide Metrics : Disabled
L1 LSDB Overload : Manual (Indefinitely in overload)
L1 LSPs : 1
L1 Default Metric : 10
L1 IPv6 Def Metric : 10
L1 Mcast IPv4 Def Metric : 10
L1 Mcast IPv6 Def Metric : 10
L1 Adv Router Cap : Enabled
Last SPF : 03/01/2024 18:17:47
SPF Wait (ms) : 10000 (Max) 1000 (Initial) 1000 (Second)
Area Addresses : None
Total Exp Routes(L1) : 0
IID TLV : Disabled
All-L1-MacAddr (Cfg) : 01:80:c2:00:00:14
L2 Auth Keychain : Disabled
L2 Auth Type : none
L2 CSNP-Authentication : Enabled
L2 HELLO-Authentication : Enabled
L2 PSNP-Authentication : Enabled
L2 Preference : 18
L2 Ext. Preference : 165
L2 Wide Metrics : Disabled
L2 LSDB Overload : Manual (Indefinitely in overload)
L2 LSPs : 1
L2 Default Metric : 10
L2 IPv6 Def Metric : 10
L2 Mcast IPv4 Def Metric : 10
L2 Mcast IPv6 Def Metric : 10
L2 Adv Router Cap : Enabled
Export Policies : None
LFA Policies : None
Ignore Attached Bit : Disabled
Suppress Attached Bit : Disabled
Default Route Tag : None
Rib Prio List High : None
Rib Prio Tag High : None
Ldp Sync Admin State : Up
LDP-over-RSVP : Disabled
RSVP-Shortcut : Disabled
Advertise-Tunnel-Link : Disabled
Export Limit : 0
Exp Lmt Log Percent : 0
Total Exp Routes(L2) : 0
All-L2-MacAddr (Cfg) : 01:80:c2:00:00:15
Loopfree-Alternate : Disabled
Remote-LFA : Disabled
Max PQ Cost : 4261412864
Remote-LFA (node-protect) : Disabled
Max PQ nodes (node-protect) : 16
TI-LFA : Disabled
Max SR FRR Labels : 2
TI-LFA (node-protect) : Disabled
L1 LFA : Included
L2 LFA : Included
Advertise Router Cap : Disabled
Ignore Lsp Errors : Disabled
Reference Bandwidth : 0
Ucast Import Disable : None
Segment Routing : Disabled
Mapping Server : Disabled
Purge Originator Id : Disabled
Entropy Label : Enabled
Override ELC : Disabled
=====

```

\* indicates that the corresponding row element may have been truncated.

Table 79: IS-IS status field descriptions

Label	Description
ISIS Oper System Id	The operational system ID mapped to the hostname
ISIS Cfg Router Id	The router ID configured for the router
ISIS Oper Router Id	The operational router ID
ASN	The autonomous system (AS) number
Admin State	Up: IS-IS is administratively up Down: IS-IS is administratively down
Oper State	Up: IS-IS is operationally up Down: IS-IS is operationally down
Ipv4 Routing	Enabled: IPv4 routing is enabled Disabled: IPv4 routing is disabled
Ipv6 Routing	Enabled: IPv6 routing is enabled Disabled: IPv6 routing is disabled
Last Enabled	The date and time that IS-IS was last enabled on the router
Level Capability	The routing level for the IS-IS routing process
Authentication Check	True: all IS-IS mismatched packets are rejected False: authentication is performed on received IS-IS protocol packets but mismatched packets are not rejected
Auth Keychain	Enabled: an authentication keychain is enabled Disabled: an authentication keychain is disabled
Authentication Type	The method of authentication used to verify the authenticity of packets sent by neighboring routers on an IS-IS interface
CSNP-Authentication	Indicates whether authentication of CSNP packets is enabled
HELLO-Authentication	Indicates whether authentication of Hello packets is enabled
PSNP Authentication	Indicates whether authentication of PSNP packets is enabled
Traffic Engineering	Enabled: TE is enabled for the router Disabled: TE is disabled; TE metrics are not generated and are ignored when received by this node

Label	Description
Overload-on-Boot Timeout	The length of time that IS-IS is in the overload state upon boot-up
Overload Max-Metric	True: the <b>max-metric</b> parameter is enabled False: the <b>max-metric</b> parameter is disabled
Overload-On-Boot Max-Metric	True: the <b>max-metric</b> parameter is enabled False: the <b>max-metric</b> parameter is disabled
LSP Lifetime	The length of time that the LSPs originated by the router are to be considered valid by other routers in the domain
LSP Wait (ms)	The length of time that the router will generate the first, second, and subsequent LSPs
LSP MTU Size	The MTU size for LSPs (configured and operational)
L1 LSP MTU Size	The MTU size for level 1 LSPs (derived from the LSP MTU size)
L2 LSP MTU Size	The MTU size for level 2 LSPs (derived from the LSP MTU size)
Adjacency Check	Type of adjacency check – always "loose"
L1 Auth Keychain	Enabled: an authentication keychain is enabled on the level 1 router Disabled: an authentication keychain is disabled on the level 1 router
L1 Auth Type	The method of authentication used to verify the authenticity of packets sent by neighboring routers to an IS-IS level 1 router
L1 CSNP-Authentication	Indicates whether authentication of CSNP packets is enabled on the level 1 router
L1 HELLO-Authentication	Indicates whether authentication of Hello packets is enabled on the level 1 router
L1 PSNP-Authentication	Indicates whether authentication of PSNP packets is enabled on the level 1 router
L1 Preference	The preference level for level 1 internal routes
L1 Ext. Preference	The preference level for level 1 external routes
L1 Wide Metrics	Indicates whether wide metrics are enabled or disabled for level 1 routers
L1 LSDB Overload	Indicates whether link-state database overload is enabled or disabled for level 1 routers
L1 LSPs	Number of LSPs sent on the level 1 router interface

Label	Description
L1 Default Metric	The default metric for the level 1 router interface
L1 IPv6 Def Metric	The default metric for the level 1 router IPv6 interface
L1 Mcast IPv4 Def Metric	The default metric for the level 1 multicast IPv4 interface
L1 Mcast IPv6 Def Metric	The default metric for the level 1 multicast IPv6 interface
L1 Adv Router Cap	The level 1 advertised router capacity
Last SPF	Date and time that the last SPF calculation was performed
SPF Wait (ms)	Length of time that the first, second, and subsequent SPF calculations are initiated after a topology change occurs
Area Addresses	The number of area addresses (area IDs) configured for the router
Total Exp Routes(L1)	Total number of routes exported from the routing table to a level 1 router
IID TLV	Indicates whether the IID TLV is enabled or disabled for this IS-IS instance
All-L1-MacAddr	Indicates the MAC address used by this level 1 router interface. For the default (base) IS-IS instance, the MAC address is 01:80:c2:00:00:14. For all other IS-IS instances, the MAC address is 01:00:5e:90:00:02.
L2 Auth Keychain	Enabled: an authentication keychain is enabled on the level 2 router Disabled: an authentication keychain is disabled on the level 2 router
L2 Auth Type	The method of authentication used to verify the authenticity of packets sent by neighboring routers to an IS-IS level 2 router
L2 CSNP-Authentication	Indicates whether authentication of CSNP packets is enabled on the level 2 router
L2 HELLO-Authentication	Indicates whether authentication of Hello packets is enabled on the level 2 router
L2 PSNP-Authentication	Indicates whether authentication of PSNP packets is enabled on the level 2 router
L2 Preference	The preference level for level 2 internal routes
L2 Ext. Preference	The preference level for level 2 external routes

Label	Description
L2 Wide Metrics	Indicates whether wide metrics are enabled or disabled for level 2 routers
L2 LSDB Overload	Indicates whether link-state database overload is enabled or disabled for level 2 routers
L2 LSPs	Number of LSPs sent on the level 2 router interface
L2 Default Metric	The default metric for the level 2 router interface
L2 IPv6 Def Metric	The default metric for the level 2 router IPv6 interface
L2 Mcast IPv4 Def Metric	The default metric for the level 2 multicast IPv4 interface
L2 Mcast IPv6 Def Metric	The default metric for the level 2 multicast IPv6 interface
L2 Adv Router Cap	The level 2 advertised router capacity
Export Policies	Indicates if export policies are applied to the router
LFA Policies	Lists the defined LFA policies
Ignore Attached Bit	Indicates whether the ATT bit is ignored on received level 1 LSPs and therefore the level 1 router does not install default routes
Suppress Attached Bit	Indicates whether the ATT bit is suppressed on originating level 1 LSPs to prevent level 1 routers from installing default routes
Default Route Tag	n/a
Rib Prio List High	n/a
Rib Prio Tag High	n/a
Ldp Sync Admin State	Indicates whether the IGP-LDP synchronization feature is enabled or disabled on all interfaces participating in the IS-IS routing protocol
LDP-over-RSVP	Indicates whether LDP over RSVP processing is enabled in IS-IS
RSVP-Shortcut	Indicates whether RSVP-TE shortcuts (IGP shortcuts) are enabled
Advertise-Tunnel-Link	Indicates whether forwarding adjacencies are enabled
Export Limit	The maximum number of routes that can be exported into IS-IS from the route table
Exp Lmt Log Percent	The percentage of the maximum number of routes at which a warning message and SNMP notification is sent

Label	Description
Total Exp Routes(L2)	Total number of routes exported from the routing table to a level 2 router
All-L2-MacAddr (Cfg)	Indicates the MAC address used by this level 2 router interface. For the default (base) IS-IS instance, the MAC address is 01:80:c2:00:00:15. For all other IS-IS instances, the MAC address is 01:00:5e:90:00:03.
Loopfree-Alternate	Indicates whether LFA is enabled
Remote-LFA	Indicates if remote LFA is enabled or disabled under the <b>loopfree-alternate</b> command
Max PQ Cost	Indicates the configured maximum PQ cost under the <b>loopfree-alternate</b> command
TI-LFA (node-protect)	Indicates if TI-LFA is enabled or disabled under the <b>loopfree-alternate</b> command
Max SR FRR Labels	The maximum number of segment routing FRR labels
L1 LFA	Indicates whether interfaces in this level are included in the LFA SPF calculation
L2 LFA	Indicates whether interfaces in this level are included in the LFA SPF calculation
Advertise Router Cap	Indicates whether router capabilities are enabled
Hello Padding	Indicates whether hello padding is enabled
L1 Hello Padding	Indicates whether level 1 hello padding is enabled
L2 Hello Padding	Indicates whether level 2 hello padding is enabled
Ignore Lsp Errors	Indicates whether ignoring LSP errors is enabled
Reference Bandwidth	Indicates configured reference bandwidth for calculating interface metrics
Ucast Import Disable	Indicates whether ISIS is configured to import its routes into RPF RTM (the multicast routing table)
Segment Routing	Indicates whether segment routing is enabled
Mapping Server	Indicates whether server mapping is enabled
Purge Originator Id	Indicates whether the Purge Originator Identification (POI) TLV is enabled
Entropy Label	Indicates whether entropy label is enabled

Label	Description
Override ELC	Indicates whether entropy label capability is enabled for BGP tunnels

## summary-address

### Syntax

**summary-address** [*ip-prefix*[/*prefix-length*]]

### Context

show>router>isis

### Description

This command displays IS-IS summary addresses for the specified IS-IS instance.

To display statistics information for all IS-IS instances, use the **show router isis all** context.

### Parameters

*ip-prefix/prefix-length*

IPv4 or IPv6 prefix and prefix length

### Output

The following output is an example of IS-IS summary address information, and [Table 80: Summary address field descriptions](#) describes the fields.

### Output example

```
A:ALU-A# show router isis summary-address
=====
Rtr Base ISIS Instance 0 Summary Address
=====
Address                               Level          Tag
10.0.0.0/8                             L1             None
10.3.3.3/32                             L2             None
-----
A:ALU-A#
```

Table 80: Summary address field descriptions

Label	Description
Address	The IP address
Level	The IS-IS level from which the prefix should be summarized
Tag	The IS-IS tag (if any) assigned to this summary address



## topology

### Syntax

**topology** [**ipv4-multicast** | **ipv6-multicast** | **ipv4-unicast** | **ipv6-unicast** | **mt** *mt-id-number*] [**lfa**] [**detail**]

### Context

show>router>isis

### Description

This command displays IS-IS topology information for the specified IS-IS instance.

To display topology information for all IS-IS instances, use the **show router isis all** context.

### Parameters

#### **ipv4-multicast**

displays IPv4 multicast parameters

#### **ipv4-unicast**

displays IPv4 unicast parameters

#### **ipv6-multicast**

displays IPv6 multicast parameters

#### **ipv6-unicast**

displays IPv6 unicast parameters

#### *mt-id-number*

displays information for the specified multitopology. The value can be 0, 2, 3, or 4.

#### **lfa**

displays LFA information

#### **detail**

displays detailed topology information

### Output

The following outputs are examples of IS-IS topology information, and [Table 81: IS-IS topology field descriptions](#) describes the fields.

#### Output example

```
A:ALU-A# show router isis topology
=====
Rtr Base ISIS Instance 0 Topology Table
=====
Node                               Interface                               Nexthop
-----
IS-IS IP paths (MT-ID 0),  Level 1
-----
7705:ALU-A.00                       ip-10.20.1.2                          7705:ALU-A
7705:ALU-A.00                       ip-10.20.3.2                          7705:ALU-A
```

```

-----
IS-IS IP paths (MT-ID 0),   Level 2
-----
7705:ALU-C.00                ip-10.20.4.1                7705:ALU-C
7705:ALU-C.00                ip-10.20.6.1                7705:ALU-C
7705:ALU-D.00                ip-10.20.4.1                7705:ALU-C
7705:ALU-D.00                ip-10.20.6.1                7705:ALU-C
7705:ALU-D.01                ip-10.20.4.1                7705:ALU-C
7705:ALU-D.01                ip-10.20.6.1                7705:ALU-C
7705:ALU-F.00                ip-10.20.13.1              7705:ALU-F
=====
    
```

A:ALU-A# show router isis topology detail

=====  
Rtr Base ISIS Instance 0 Topology Table  
=====

```

-----
IS-IS IP paths (MT-ID 0),   Level 1
-----
    
```

```

Node       : 7705:ALU-A.00           Metric      : 10
Interface  : ip-10.20.1.2           SNPA        : none
Nexthop    : 7705:ALU-A

Node       : 7705:ALU-A.00           Metric      : 10
Interface  : ip-10.20.3.2           SNPA        : none
Nexthop    : 7705:ALU-A
    
```

```

-----
IS-IS IP paths (MT-ID 0),   Level 2
-----
    
```

```

Node       : 7705:ALU-C.00           Metric      : 10
Interface  : ip-10.20.4.1           SNPA        : none
Nexthop    : 7705:ALU-C

Node       : 7705:ALU-C.00           Metric      : 10
Interface  : ip-10.20.6.1           SNPA        : none
Nexthop    : 7705:ALU-C

Node       : 7705:ALU-D.00           Metric      : 20
Interface  : ip-10.20.4.1           SNPA        : none
Nexthop    : 7705:ALU-C

Node       : 7705:ALU-D.00           Metric      : 20
Interface  : ip-10.20.6.1           SNPA        : none
Nexthop    : 7705:ALU-C

Node       : 7705:ALU-D.01           Metric      : 20
Interface  : ip-10.20.4.1           SNPA        : none
Nexthop    : 7705:ALU-C

Node       : 7705:ALU-D.01           Metric      : 20
Interface  : ip-10.20.6.1           SNPA        : none
Nexthop    : 7705:ALU-C

Node       : 7705:ALU-F.00           Metric      : 10
Interface  : ip-10.20.13.1          SNPA        : none
Nexthop    : 7705:ALU-F
    
```

=====  
A:ALU-A#

\*A: Sar18 Dut-B>show>router# isis topology lfa

```

=====
Rtr Base ISIS Instance 0 Topology Table
=====
Node                               Interface                               Nexthop
                                LFA Interface                           LFA Nexthop
-----
No Matching Entries
=====
*A: Sar18 Dut-B>show>router#
    
```

```

A: ALU-A# show router isis topology lfa detail
=====
Rtr Base ISIS Instance 0 Topology Table
=====
IS-IS IP paths (MT-ID 0), Level 1
-----
Node       : 7705:ALU-A.00           Metric    : 10
Interface  : ip-10.20.1.2           SNPA      : none
Nexthop    : 7705:ALU-A

Node       : 7705:ALU-A.00           Metric    : 10
Interface  : ip-10.20.3.2           SNPA      : none
Nexthop    : 7705:ALU-A

Node       : 7705:ALU-D.00           Metric    : 20
Interface  : ip-10.20.6.1           SNPA      : 00:00:00:00:00:02
Nexthop    : 7705:ALU-B

LFA intf   : to_ALU-C1              LFA Metric : 40
LFA nh     : 7705:ALU-E             LFA type   : nodeProtection
-----
IS-IS IP paths (MT-ID 0), Level 2
-----
Node       : 7705:ALU-C.00           Metric    : 10
Interface  : ip-10.20.4.1           SNPA      : none
Nexthop    : 7705:ALU-C

Node       : 7705:ALU-C.00           Metric    : 10
Interface  : ip-10.20.6.1           SNPA      : none
Nexthop    : 7705:ALU-C

Node       : 7705:ALU-D.00           Metric    : 20
Interface  : ip-10.20.4.1           SNPA      : none
Nexthop    : 7705:ALU-C

Node       : 7705:ALU-D.00           Metric    : 20
Interface  : ip-10.20.6.1           SNPA      : none
Nexthop    : 7705:ALU-C

Node       : 7705:ALU-D.01           Metric    : 20
Interface  : ip-10.20.4.1           SNPA      : none
Nexthop    : 7705:ALU-C

Node       : 7705:ALU-D.01           Metric    : 20
Interface  : ip-10.20.6.1           SNPA      : none
Nexthop    : 7705:ALU-C

Node       : 7705:ALU-F.00           Metric    : 10
Interface  : ip-10.20.13.1          SNPA      : none
Nexthop    : 7705:ALU-F
    
```

```
-----
A:ALU-A#
```

Table 81: IS-IS topology field descriptions

Label	Description
Node	The IP address
Interface	The interface name
Nexthop	The next-hop IP address
Metric	The route metric for the route
SNPA	The subnetwork points of attachment (SNPA) where a router is physically attached to a subnetwork
LFA intf LFA interface	The LFA interface name
LFA Metric	The route metric for the LFA backup route
LFA nh LFA nexthop	The LFA next hop
LFA type	The LFA protection type: link protection or node protection

### 5.11.2.3 Clear commands

```
isis
```

#### Syntax

```
isis [isis-instance]
```

#### Context

```
clear>router
```

#### Description

This command enables the context to clear IS-IS information.

#### Parameters

*isis-instance*

the IS-IS instance ID. If no *isis-instance* is specified, instance 0 is used.

**Values** 0 to 31

## adjacency

### Syntax

**adjacency** [*system-id*]

### Context

clear>router>isis

### Description

This command clears and resets the entries from the IS-IS adjacency database.

### Parameters

*system-id*

6-octet system identifier in the form xxxx.xxxx.xxxx

## database

### Syntax

**database** [*system-id*]

### Context

clear>router>isis

### Description

This command removes the entries from the IS-IS link-state database that contains information about PDUs.

### Parameters

*system-id*

6-octet system identifier in the form xxxx.xxxx.xxxx

## export

### Syntax

**export**

### Context

clear>router>isis

**Description**

This command re-evaluates the route policies for IS-IS.

`spf-log`

**Syntax**

`spf-log`

**Context**

`clear>router>isis`

**Description**

This command clears the SPF log.

`statistics`

**Syntax**

`statistics`

**Context**

`clear>router>isis`

**Description**

This command clears and resets all IS-IS statistics.

## 5.11.2.4 Monitor commands

`isis`

**Syntax**

`isis [isis-instance]`

**Context**

`monitor>router`

**Description**

This command enables the context to monitor IS-IS information.

**Parameters***isis-instance*the IS-IS instance ID; if no *isis-instance* is specified, instance 0 is used**Values** 0 to 31**statistics****Syntax****statistics** [*interval seconds*] [*repeat repeat*] [*absolute* | *rate*]**Context**

monitor&gt;router&gt;isis

**Description**

This command monitors statistics for IS-IS instances.

**Parameters***seconds*

specifies the interval for each display in seconds

**Values** 3 to 60**Default** 10*repeat*

specifies the number of times the command is repeated

**Values** 1 to 999**Default** 10**absolute**

specifies that raw statistics are displayed, without processing. No calculations are performed on the delta or rate statistics.

**rate**

specifies the rate per second for each statistic instead of the delta

**Output**

The following output is an example of statistics information for a router IS-IS instance.

**Output example**

```
A:7705custDoc:Sar18>monitor>router>isis# statistics
=====
ISIS Statistics
=====
-----
```

```

At time t = 0 sec (Base Statistics)
-----
ISIS Instance      : 0                SPF Runs      : 0
Purge Initiated   : 0                LSP Regens.   : 73
CSPF Statistics
Requests          : 0                Request Drops : 0
Paths Found       : 0                Paths Not Found: 0
-----
PDU Type  Received  Processed  Dropped   Sent      Retransmitted
-----
LSP        0         0         0         0         0
IIH        0         0         0         0         0
CSNP       0         0         0         0         0
PSNP       0         0         0         0         0
Unknown    0         0         0         0         0
-----
At time t = 10 sec (Mode: Delta)
-----
ISIS Instance      : 0                SPF Runs      : 0
Purge Initiated   : 0                LSP Regens.   : 0
CSPF Statistics
Requests          : 0                Request Drops : 0
Paths Found       : 0                Paths Not Found: 0
-----
PDU Type  Received  Processed  Dropped   Sent      Retransmitted
-----
LSP        0         0         0         0         0
IIH        0         0         0         0         0
CSNP       0         0         0         0         0
PSNP       0         0         0         0         0
Unknown    0         0         0         0         0
-----
At time t = 20 sec (Mode: Delta)
-----
ISIS Instance      : 0                SPF Runs      : 0
Purge Initiated   : 0                LSP Regens.   : 0
CSPF Statistics
Requests          : 0                Request Drops : 0
Paths Found       : 0                Paths Not Found: 0
-----
PDU Type  Received  Processed  Dropped   Sent      Retransmitted
-----
LSP        0         0         0         0         0
IIH        0         0         0         0         0
CSNP       0         0         0         0         0
PSNP       0         0         0         0         0
Unknown    0         0         0         0         0
-----

```

### 5.11.2.5 Debug commands

#### isis

#### Syntax

**isis** [*isis-instance*]



**Context**

```
debug>router
```

**Description**

This command enables the context to debug IS-IS information.

**Parameters**

*isis-instance*

the IS-IS instance ID. If no *isis-instance* is specified, instance 0 is used.

**Values** 0 to 31

**adjacency****Syntax**

```
[no] adjacency [ip-int-name | ip-address | nbr-system-id]
```

**Context**

```
debug>router>isis
```

**Description**

This command enables or disables debugging for IS-IS adjacency.

**Parameters**

*ip-int-name*

debugs only adjacencies with the specified interface

*ip-address*

debugs only adjacencies with the specified IPv4 or IPv6 address

*nbr-system-id*

debugs only the adjacency with the specified system ID

**cspf****Syntax**

```
[no] cspf
```

**Context**

```
debug>router>isis
```

**Description**

This command enables or disables debugging for an IS-IS constraint-based shortest path first (CSPF).

## interface

### Syntax

```
interface [ip-int-name | ip-address]
```

```
no interface
```

### Context

```
debug>router>isis
```

### Description

This command enables or disables debugging for an IS-IS interface.

### Parameters

*ip-int-name*

the IP interface name. An interface name cannot be in the form of an IP address. Interface names can be any string up to 32 characters long composed of printable, 7-bit ASCII characters. If the string contains special characters (such as #, \$, or spaces), the entire string must be enclosed within double quotes.

*ip-address*

the interface IPv4 or IPv6 address

## leak

### Syntax

```
leak [ip-address]
```

```
no leak
```

### Context

```
debug>router>isis
```

### Description

This command enables or disables debugging for IS-IS leaks.

### Parameters

*ip-address*

the IPv4 or IPv6 address to debug for IS-IS leaks

## lsdb

### Syntax

[no] lsdb [*level-number*] [*system-id* | *lsp-id*]

### Context

debug>router>isis

### Description

This command enables or disables debugging for the IS-IS link-state database.

### Parameters

*level-number*

1 or 2

*system-id*

6-octet system identifier in the form xxxx.xxxx.xxxx

*lsp-id*

the hostname (38 characters maximum)

## misc

### Syntax

[no] misc

### Context

debug>router>isis

### Description

This command enables or disables debugging for miscellaneous IS-IS events.

## packet

### Syntax

[no] packet [*packet-type*] [*ip-int-name* | *ip-address* | *ipv6-address*] [**detail**]

### Context

debug>router>isis

### Description

This command enables or disables debugging for IS-IS packets.

**Parameters***packet-type*

the IS-IS packet type to debug

**Values** ptop-hello | l1-hello | l2-hello | l1-psnp | l2-psnp | l1-csnp | l2-csnp | l1-lsp | l2-lsp

*ip-int-name*

the IP interface name. An interface name cannot be in the form of an IP address. Interface names can be any string up to 32 characters long composed of printable, 7-bit ASCII characters. If the string contains special characters (such as #, \$, or spaces), the entire string must be enclosed within double quotes.

*ip-address*

the IPv4 address to debug

*ipv6-address*

the IPv6 address to debug

**detail**

provides detailed debugging information

**rtm****Syntax**

**rtm** [*ip-address*]

**no rtm**

**Context**

debug>router>isis

**Description**

This command enables or disables debugging for the IS-IS routing table manager.

**Parameters***ip-address*

the IPv4 or IPv6 address to debug

**spf****Syntax**

**[no] spf** [*level-number*] [*system-id*]

**Context**

debug>router>isis

**Description**

This command enables or disables debugging for IS-IS SPF calculations.

**Parameters**

*level-number*

1 or 2

*system-id*

6-octet system identifier in the form xxxx.xxxx.xxxx

## 6 BGP

This chapter provides information about configuring BGP.

Topics in this chapter include:

- [BGP overview](#)
- [Group configuration and peers](#)
- [BGP route tunnels](#)
- [Command interactions and dependencies](#)
- [BGP configuration process overview](#)
- [Configuration notes](#)
- [Configuring BGP with CLI](#)
- [BGP command reference](#)

### 6.1 BGP overview

Border Gateway Protocol (BGP) is an inter-autonomous system routing protocol. An autonomous system (AS) is a network or a group of routers logically organized and controlled by a common network administration. BGP enables routers to exchange network reachability information, including information about other ASs that traffic must traverse to reach other routers in other ASs. In order to implement BGP, the AS number must be specified in the **config>router** context. A 7705 SAR BGP configuration must contain at least one group (a collection of related BGP peers) and include information about at least one neighbor (peer).

AS paths are the routes to each destination. Other attributes, such as the path's origin, the system's route preference, aggregation, route reflection, and communities included in the AS path are called path attributes. When BGP interprets routing and topology information, loops can be detected and eliminated. Route preference for routes learned from the configured peers can be enabled among groups of routes to enforce administrative preferences and routing policy decisions.

This section contains information about the following topics:

- [BGP communication](#)
- [Message types](#)
- [BGP path attributes](#)
- [Multiprotocol BGP attributes](#)
- [BGPv6](#)
- [BGP add-paths](#)
- [Outbound route filtering \(ORF\)](#)
- [BGP route target constrained route distribution](#)

## 6.1.1 BGP communication

There are two types of BGP peers: internal BGP (IBGP) peers and external BGP (EBGP) peers (see [Figure 38: BGP configuration](#)).

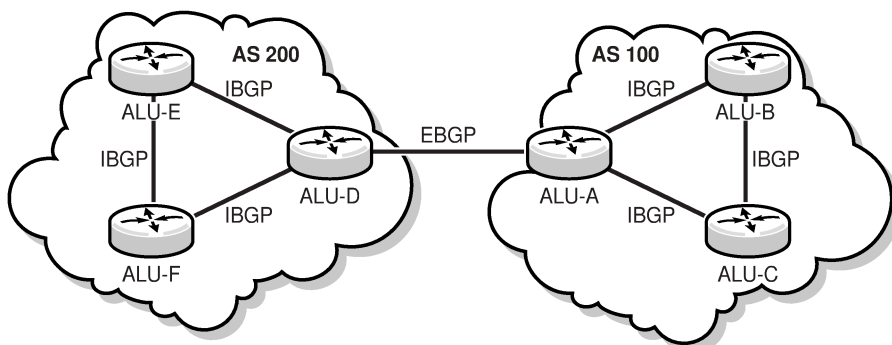
- Within an AS, IBGP is used to communicate with peers.
- Between ASs, EBGP is used to communicate with peers. Routes received from a router in a different AS can be advertised to both EBGP and IBGP peers.

In an external group, the next hop depends upon the interface shared between the external peer and the specific neighbor. The **multihop** command must be specified if an EBGP peer is more than one hop away from the local router.

The 7705 SAR supports EBGP within the router context and VPRN context. For information about configuring EBGP within the VPRN context, see the 7705 SAR Services Guide, "VPRN Services". IBGP is supported within a router context but not within a VPRN context.

Autonomous systems use BGP to share routing information—such as routes to each destination and information about the route or AS path—with other ASs. Routing tables contain lists of known routers, reachable addresses, and associated path cost metrics to each router. BGP uses the information and path attributes to compile a network topology.

Figure 38: BGP configuration



20109

### 6.1.1.1 Static and dynamic neighbors

The 7705 SAR supports both statically configured and dynamic (unconfigured) BGP sessions. Statically configured BGP sessions are configured using the BGP group **neighbor ip-address** command. Dynamic sessions are established using one or more **prefix** commands in the BGP group **dynamic-neighbor** context. The **neighbor** command accepts either an IPv4 or IPv6 address, which allows the session transport to be IPv4 or IPv6. By default, the router is the active side of TCP connections to statically configured remote peers, meaning that as soon as a session leaves the idle state, the router attempts to set up an outgoing TCP connection to the remote neighbor and listens on TCP port 179 for an incoming connection from the peer. If required, a statically configured BGP session can be configured for **passive** mode, meaning that the router only listens for an incoming connection and does not attempt to set up the outgoing connection. For dynamic sessions, the router always operates in **passive** mode.

The source IP address used to set up the TCP connection to the static or dynamic peer can be configured explicitly using the **local-address** command. If a **local-address** is not configured, the source IP address is determined as follows:

- if the neighbor's IP address belongs to a local subnet, the source IP address is the local router's interface IP address on that subnet
- if the neighbor's IP address does not belong to a local subnet, the source IP address is the local router's system IP address

Configuring the router interface as the local address can be done in the **config>router>bgp>group** context and the **config>router>bgp>group>neighbor** context.

When the router interface is configured as the local address, BGP inherits the IP address from the interface as follows:

- BGP-4 sessions – the primary IPv4 address configured on the interface is used as the local address
- BGPv6 sessions – the primary IPv6 address configured on the interface is used as the local address

If the corresponding IPv4 or IPv6 address is not configured on the router interface, the BGP sessions that have this interface set as the local address are kept in the down state until an interface address is configured on the router interface.

If the primary IPv4 or IPv6 address is changed on the router interface and that interface is being used as the local address for BGP, BGP will bounce the link. Bouncing the link causes all routes advertised using the previous address to be removed and readvertised using the newly configured IP address.

## 6.1.2 Message types

Four message types are used by BGP to negotiate parameters, exchange routing information and indicate errors. They are:

- Open message – after a transport protocol connection is established, the first message sent by each side is an Open message. If the Open message is acceptable, a Keepalive message confirming the Open message is sent back. Once the Open message is confirmed, Update, Keepalive, and Notification messages can be exchanged.

Open messages consist of the BGP header and the following fields:

- version – the current BGP version number is 4
  - local AS number – the autonomous system number is configured in the **config>router** context
  - hold time – the maximum time BGP will wait between successive messages (either Keepalive or Update) from its peer, before closing the connection. Configure the local hold time within the **config>router>bgp** context.
  - BGP identifier – IP address of the BGP domain or the router ID. The router ID must be a valid host address.
- Update message – Update messages are used to transfer routing information between BGP peers. The information contained in the packet can be used to construct a graph describing the relationships of the various autonomous systems. By applying rules, routing information loops and some other anomalies can be detected and removed from the inter-AS routing.

The Update messages consist of a BGP header and the following optional fields:

- unfeasible routes length – the length of the field that lists the routes being withdrawn from service because they are considered unreachable



- withdrawn routes – the associated IP address prefixes for the routes withdrawn from service
- total path attribute length – the total length of the path field that provides the attributes for a possible route to a destination
- path attributes – the path attributes presented in variable-length TLV format
- network layer reachability information (NLRI) – IP address prefixes of reachability information
- Keepalive message – Keepalive messages, consisting of only a 19-octet message header, are exchanged between peers frequently so hold timers do not expire. The Keepalive messages determine if a link is unavailable.
- Notification message – a Notification message is sent when an error condition is detected. The peering session is terminated and the BGP connection (TCP connection) is closed immediately after sending it.

### 6.1.2.1 Update message error handling

To ensure protocol correctness, the original BGP protocol specification in RFC 4271 called for all Update message errors to be handled by sending a Notification message to the peer and immediately closing the BGP session. This error handling approach ignored the following points:

- Not all Update message errors have the same severity. A critical error only occurs if the NLRI cannot be extracted and parsed from an Update message. Other errors, such as incorrect attribute flag settings, missing mandatory path attributes, or incorrect next-hop length or format, can be considered noncritical and handled differently.
- Session resets negatively impact the stability and performance of the network and for many types of Update message errors, such as software or hardware errors or a misconfiguration, a session reset does not solve the problem because the root cause remains. If a session reset is absolutely necessary, the operator should have some control over the timing.
- Some degree of protocol incorrectness is tolerable for a short period of time as long as the network operator is fully aware of the issue. In this context, incorrectness typically means a BGP RIB inconsistency between routers in the same AS. This inconsistency is less of an issue because edge-to-edge tunneling of IP traffic (for example, BGP shortcuts or IP VPN) reduces the number of deployments where IP traffic is forwarded hop-by-hop.

RFC 7606 describes revised error handling for BGP Update messages using the “treat-as-withdraw” or “attribute-discard” approach. The 7705 SAR supports updated BGP error handling for individual BGP sessions or automatically for all BGP sessions. The **update-fault-tolerance** command can be configured at the BGP global, group, or neighbor level and the configuration can be applied to a BGP session at that level to cause noncritical errors to be handled using the “treat-as-withdraw” or “attribute-discard” approach, which does not cause a session reset. If **update-fault-tolerance** is not configured, all errors (critical and noncritical) trigger a session reset. If the **legacy-mode** command is disabled, **update-fault-tolerance** configurations are ignored and updated fault protection is automatically applied to all BGP sessions. The **update-fault-tolerance** and **legacy-mode** commands are supported at the base router level and at the VPRN service level

If the **update-fault-tolerance** or **no legacy-mode** command is configured and a noncritical error is triggered, the BGP session is reset if updated fault tolerance is disabled.

#### Malformed NLRI handling

Some address families, such as EVPN, MVPN, and BGP-LS, have NLRI that are typed. Because supported type values within the address family are not expressed in the MP-BGP capability fields, it

is possible for a BGP speaker to advertise support for the address family and sub-address family while still not supporting a particular type of NLRI within that AFI or SAFI. As per RFC 7606, a BGP speaker advertising support for a typed address family must handle routes with unrecognized NLRI types within that address family by discarding them.

Whether the **update-fault-tolerance** command is configured or not, the 7705 SAR handles malformed NLRI as follows:

- if an MVPN route is received with an unsupported route type, that route type will be skipped and the session will not be reset. An invalid NLRI log event will be generated indicating the unknown route type value.
- if an EVPN route is received with an unsupported route type, that route type will be skipped and an invalid NLRI log event will be generated indicating the unknown route type value
- if a BGP-LS route is received with an unsupported NLRI type, that NLRI type will be skipped and an invalid NLRI log event will be generated indicating the unknown NLRI type value

### Malformed path attributes

When **update-fault-tolerance** is configured and any of the following malformed path attributes are received in a BGP route from an EBGP peer they are discarded using the “attribute discard” approach:

- length of LOCAL\_PREF is not 4
- length of ORIGINATOR\_ID is not 4
- length of CLUSTER\_LIST is not a non-zero multiple of 4

When **update-fault-tolerance** is not configured, the determination that these attributes are malformed based on length comes before the peer type (EBGP vs IBGP) is considered, and the “treat as withdraw” approach is applied instead.

## 6.1.3 BGP path attributes

Path attributes are fundamental to BGP. A BGP route for a particular NLRI is distinguished from other BGP routes for the same NLRI by the set of path attributes for the route. Each path attribute describes some property of the path and is encoded as a TLV in the Path Attributes field of the Update message. The Type field of the TLV identifies the path attribute and the Value field carries data specific to the attribute type. There are four categories of path attributes:

- well-known mandatory

These attributes must be recognized by all BGP routers and must be present in every Update message that advertises reachable NLRI toward a specific type of neighbor (EBGP or IBGP).

- well-known discretionary

These attributes must be recognized by all BGP routers but are not required in every Update message.

- optional transitive

These attributes do not need to be recognized by all BGP routers. If a BGP router does not recognize one of these attributes, it accepts it and passes it on to other BGP peers.

- optional non-transitive

These attributes do not need to be recognized by all BGP routers. If a BGP router does not recognize one of these attributes, it is quietly ignored and not passed on to other BGP peers.

The 7705 SAR supports the following path attributes:

- ORIGIN (well-known mandatory)
- AS\_PATH (well-known mandatory)
- NEXT\_HOP (well-known, mandatory only in Update messages with IPv4 prefixes in the NLRI field)
- MED (optional non-transitive)
- LOCAL\_PREF (well-known, mandatory only in Update messages sent to IBGP peers)
- ATOMIC\_AGGREGATE (well-known discretionary)
- AGGREGATOR (optional transitive)
- COMMUNITIES (optional transitive)
- ORIGINATOR\_ID (optional non-transitive)
- CLUSTER\_LIST (optional non-transitive)
- MP\_REACH\_NLRI (optional non-transitive)
- MP\_UNREACH\_NLRI (optional non-transitive)
- EXT\_COMMUNITY (optional transitive)
- AS4\_PATH (optional transitive)
- AS4\_AGGREGATOR (optional transitive)
- CONNECTOR (optional transitive)
- PMSI\_TUNNEL (optional transitive)
- TUNNEL\_ENCAPSULATION (optional transitive)
- AIGP (optional non-transitive)
- BGP-LS (optional non-transitive)

### 6.1.3.1 Origin attribute

The ORIGIN attribute indicates the origin of the path information. There are three supported values:

- IGP (0) – the prefix was originated from information learned from an interior gateway protocol
- EGP (1) – the prefix originated from an exterior gateway protocol (BGP)
- Incomplete (2) – the prefix originated from an unknown source

### 6.1.3.2 AS path attribute

The AS\_PATH attribute contains the list of ASs through which the routing information has passed.

The AS numbers in the AS\_PATH attribute are all 2-byte values or all 4-byte values (if the 4-octet ASN capability was announced by both peers).

### 6.1.3.3 Next-hop attribute

The NEXT\_HOP attribute indicates the IPv4 address of the BGP router that is the next hop to reach the IPv4 prefixes in the NLRI field. If the Update message is advertising routes other than IPv4 unicast

routes, the next hop of these routes is encoded in the MP\_REACH\_NLRI attribute; see [Multiprotocol BGP extensions attributes](#) for more details.

### 6.1.3.3.1 VPN-IPv4 routes

The 7705 SAR can send and receive VPN-IPv4 routes with IPv4 next hops. When the **extended-nh-encoding** command is configured, the 7705 SAR can receive VPN-IPv4 routes with IPv6 next-hop addresses from selected BGP peers by signaling the corresponding extended next-hop encoding BGP capability to those peers during session setup. The peers should not send these routes unless they receive notification of this capability. If the 7705 SAR router does not receive an extended next-hop encoding capability advertisement for VPN-IPv4 NLRI and IPv6 next hop (NLRI AFI=1, NLRI SAFI=128, next hop AFI=2) from a peer, then it will not advertise VPN-IPv4 routes with IPv6 next hops to that peer.

When a VPN-IPv4 BGP route is reflected from one IBGP peer to another IBGP peer, the route reflector does not modify the next hop by default. However, if **enable-rr-vpn-forwarding** is configured and the **next-hop-self** command is applied to the IBGP peer receiving the route, the next hop is modified in one of the following ways:

- if the IBGP session receiving the reflected route uses IPv4 transport, the BGP next hop is taken from the value of the local address used to set up the session
- if the IBGP session receiving the reflected route opened an IPv6 transport session by advertising an extended next-hop encoding capability (NLRI AFI=1, NLRI SAFI=128, next hop AFI=2) and the session on the local router is associated with an **advertise-ipv6-next-hops vpn-ipv4** command, the BGP next hop is set to the value of the IPv6 local address used for setup of the session. Otherwise, the BGP next hop is set to the IPv4 address of the system interface.

When a VPN-IPv4 BGP route is reflected from one IBGP peer to another IBGP peer and **enable-rr-vpn-forwarding** is configured and the VPN-IPv4 route is matched and accepted by an export policy entry with a **next-hop ip-address** action, the BGP next hop of the matched routes typically changes to this IP address. However if the next hop is an IPv6 address and the receiving IBGP peer did not advertise a matching extended next-hop encoding capability, or if the session on the local router is not associated with an **advertise-ipv6-next-hops vpn-ipv4** command, the route is treated as though it was rejected by the policy entry.

### 6.1.3.3.2 VPN-IPv6 routes

The 7705 SAR router never sends or receives VPN-IPv6 routes with 32-bit IPv4 next-hop addresses.

When a VPN-IPv6 BGP route is advertised to an EBGP peer there is no change to the next hop.

When a VPN-IPv6 BGP route is reflected from one IBGP peer to another IBGP peer, the route reflector does not modify the next hop by default. However, if **enable-rr-vpn-forwarding** is configured and the **next-hop-self** command is applied to the IBGP peer receiving the route, the next hop is modified in one of the following ways:

- if the IBGP session receiving the reflected route uses IPv4 transport, the BGP next hop is set to the IPv4 local address used to set up the session but encoded as an IPv4-mapped IPv6 address (for example, with the IPv4 address in the least significant 32 bits of a `::FFFF/96` prefix)
- if the IBGP session receiving the reflected route uses IPv6 transport and is associated with an **advertise-ipv6-next-hops vpn-ipv6** command, the BGP next hop is set to the value of the IPv6 local address used for setup of the session. Otherwise, the BGP next hop is set to the IPv4 address of the

system interface encoded as an IPv4-mapped IPv6 address (for example, with the IPv4 address in the least significant 32 bits of a `::FFFF/96` prefix).

When a VPN-IPv6 BGP route is reflected from one IBGP peer to another IBGP peer and **enable-rr-vpn-forwarding** is configured and the VPN-IPv6 route is matched and accepted by an export policy entry with a **next-hop ip-address** action, the BGP next hop of the matched routes changes to this IP address if it is specified as a 128-bit IPv6 address or changes to an IPv4-mapped IPv6 address encoding the IP address if it is specified as a 32-bit IPv4 address.

### 6.1.3.3.3 Label-IPv4 routes

The 7705 SAR can send and receive label-IPv4 routes with IPv4 next hops. When the **extended-nh-encoding** command is configured, the 7705 SAR can receive label-IPv4 routes with IPv6 next-hop addresses from selected BGP peers by signaling the corresponding extended next-hop encoding BGP capability to those peers during session setup. The peers should not send these routes unless they receive notification of this capability. If the 7705 SAR router does not receive an extended next-hop encoding capability advertisement for label-IPv4 NLRI and IPv6 next hop (NLRI AFI=1, NRLI SAFI=4, next hop AFI=2) from a peer, then it will not advertise label-IPv4 routes with IPv6 next hops to that peer.

When a label-IPv4 BGP route is advertised to an EBGp peer, **next-hop-self** is used with one of the following outcomes:

- if the EBGp session uses IPv4 transport, the BGP next hop is taken from the value of the local address used to set up the session
- if the EBGp peer opened an IPv6 transport session by advertising an extended next-hop encoding capability (NLRI AFI=1, NRLI SAFI=4, next-hop AFI=2) and the session on the local router is associated with an **advertise-ipv6-next-hops label-ipv4** command, the BGP next hop is set to the value of the IPv6 local address used to set up the session. Otherwise, the BGP next hop is set to the IPv4 address of the system interface.

When a label-IPv4 BGP route is reflected from one IBGP peer to another IBGP peer, the route reflector does not modify the next hop by default. However, if the **next-hop-self** command is applied to the IBGP peer receiving the route, the next hop is modified in one of the following ways:

- if the IBGP session receiving the reflected route uses IPv4 transport, the BGP next hop is taken from the value of the local-address used to setup the session
- if the IBGP session receiving the reflected route opened an IPv6 transport session by advertising an extended next-hop encoding capability (NLRI AFI=1, NRLI SAFI=4, next-hop AFI=2) and, in the configuration of the local router, the session is associated with an **advertise-ipv6-next-hops label-ipv4** command, the BGP next hop is set to the value of the IPv6 local address used for setup of the session. Otherwise, the BGP next hop is set to the IPv4 address of the system interface.

When a label-IPv4 BGP route is reflected from one IBGP peer to another IBGP peer and the label-IPv4 route is matched and accepted by an export policy entry with a **next-hop ip-address** action, the BGP next hop of the matched routes typically changes to match the specified IP address. However, if the next hop is an IPv6 address and the receiving IBGP peer did not advertise an extended next-hop encoding capability (NLRI AFI=1, NRLI SAFI=4, next-hop AFI=2) or, in the configuration of the local router, the session is not associated with an **advertise-ipv6-next-hops label-ipv4** command, the route is treated as though it was rejected by the policy entry.

### 6.1.3.3.4 Label-IPv6 routes

The 7705 SAR router never sends or receives label-IPv6 routes with 32-bit IPv4 next-hop addresses. There is no support for sending or receiving label-IPv6 routes to or from EBGp peers, although the 7705 SAR does not block the address family from being configured and advertised as a capability toward EBGp peers.

When a label-IPv6 BGP route is reflected from one IBGP peer to another IBGP peer, the route reflector does not modify the next hop by default. However, if the **next-hop-self** command is applied to the IBGP peer receiving the route, the next hop is modified in one of the following ways:

- if the IBGP session receiving the reflected route uses IPv4 transport, the BGP next hop is set to the IPv4 local address used to set up the session but encoded as an IPv4-mapped IPv6 address (for example, with the IPv4 address in the least significant 32 bits of a `::FFFF/96` prefix)
- if the IBGP session receiving the reflected route uses IPv6 transport and is associated with an **advertise-ipv6-next-hops label-ipv6** command, the BGP next hop is set to the value of the IPv6 local address used for setup of the session. Otherwise, the BGP next hop is set to the IPv4 address of the system interface encoded as an IPv4-mapped IPv6 address (for example, with the IPv4 address in the least significant 32 bits of a `::FFFF/96` prefix).

When a label-IPv6 BGP route is reflected from one IBGP peer to another IBGP peer and the label-IPv6 route is matched and accepted by an export policy entry with a **next-hop ip-address** action, the BGP next hop of the matched routes changes to this IP address if it is specified as a 128-bit IPv6 address or changes to an IPv4-mapped IPv6 address encoding the IP address if it is specified as a 32-bit IPv4 address.

### 6.1.3.4 MED attribute

The Multi-Exit Discriminator (MED) attribute is an optional attribute that can be added to routes advertised to an EBGp peer to influence the flow of inbound traffic to the AS. The MED attribute carries a 32-bit metric value. A lower metric is better than a higher metric when MED attributes are compared during the BGP decision process. Unless the **always-compare-med** command is configured, MED attributes are compared only if the routes come from the same neighbor AS. By default, if a route is received without a MED attribute, it is evaluated by the BGP decision process as though it had a MED containing the value 0. This can be changed so that a missing MED attribute is handled in the same way as a MED with the maximum value. The 7705 SAR always removes the received MED attribute when advertising the route to an EBGp peer.

### 6.1.3.5 Local preference attribute

The LOCAL\_PREF attribute is a well-known attribute that should be included in every route advertised to an IBGP peer. It is used to influence the flow of outbound traffic from the AS. The local preference is a 32-bit value, and higher values are more preferred by the BGP decision process. The LOCAL\_PREF attribute is not included in routes advertised to EBGp peers. If the attribute is received from an EBGp peer, it is ignored.



### 6.1.3.6 Route aggregation path attributes

An aggregate route is a group of routes with a common prefix that are combined into a single entry in the forwarding table (for more information, see the **aggregate** command in the 7705 SAR Router Configuration Guide, "Router Global Commands").

An active aggregate route can be advertised to a BGP peer by exporting it into BGP. This reduces the number of routes that need to be advertised to the peer and reduces the number of routes in the peer AS. When a router advertises an aggregate route to a BGP peer, the aggregation attributes in the route are set as follows:

- The **ATOMIC\_AGGREGATE** attribute is included in the route if at least one contributing route has the **ATOMIC\_AGGREGATE** attribute, or the aggregate route was formed without the **as-set** option in the **config>router>aggregate** context and at least one contributing route has a non-empty **AS\_PATH**. The **ATOMIC\_AGGREGATE** attribute indicates that some of the AS numbers present in the AS paths of the contributing routes are missing from the advertised **AS\_PATH**.
- The **AGGREGATOR** attribute is added to the route. This attribute encodes, by default, the global AS number and router ID (BGP identifier) of the router that formed the aggregate, but these values can be changed on a per-aggregate route basis using the **aggregator** command option in the **config>router>aggregate** context. The AS number in the **AGGREGATOR** attribute is either 2 bytes or 4 bytes (if the 4-octet ASN capability was announced by both peers). The router ID in the aggregate routes advertised to a particular set of peers can be set to 0.0.0.0 using the **aggregator-id-zero** command in the **config>router>bgp** context.

### 6.1.3.7 Communities attribute

A BGP route can be associated with one or more communities. There are two kinds of BGP communities supported by the 7705 SAR:

- standard communities (each 4 bytes in length, all packed into a path attribute with type code 8)
- extended communities (each 8 bytes in length, with potentially many possible subtypes, all packed into a path attribute with type code 16)

For information about communities, see the 7705 SAR Router Configuration Guide, "Route Policies".

The **COMMUNITIES** attribute is an optional transitive attribute of variable length. The attribute consists of a set of four octet values, each of which specifies a community. All routes with this attribute belong to the communities listed in the attribute.

The following communities are well-known standard communities that should be recognized by all BGP routers:

- **NO\_EXPORT** – a route that carries this community must not be advertised outside the local AS
- **NO\_ADVERTISE** – a route that carries this community must not be advertised to any other BGP peer
- **NO\_EXPORT\_SUBCONFED** – a route that carries this community must not be advertised outside a member AS boundary to external BGP peers

### 6.1.3.8 Route reflection attributes

The **ORIGINATOR\_ID** and **CLUSTER\_LIST** attributes are optional non-transitive attributes that are used in route reflection; see [Route reflection](#).

### 6.1.3.9 Multiprotocol BGP extensions attributes

Multiprotocol extensions for BGP (MP-BGP) allow BGP peers to exchange routes for NLRI other than IPv4 prefixes; for example, IPv6 prefixes or Layer 3 VPN routes. A BGP router that supports MP-BGP indicates the types of routes it wants to exchange with a peer by including the corresponding AFI (Address Family Identifier) and SAFI (Subsequent Address Family Identifier) values in the MP-BGP capability fields of its Open message.

To advertise reachable routes of a particular AFI/SAFI, a BGP router includes a single MP\_REACH\_NLRI attribute in the Update message. The MP\_REACH\_NLRI attribute encodes the AFI, the SAFI, the BGP next hop, and all the reachable NLRI.

To withdraw routes of a particular AFI/SAFI, a BGP router includes a single MP\_UNREACH\_NLRI attribute in the Update message. The MP\_UNREACH\_NLRI attribute encodes the AFI, the SAFI, and all the withdrawn NLRI.

### 6.1.3.10 4-octet AS attributes

The AS4\_PATH and AS4\_AGGREGATOR attributes are optional transitive attributes that support the gradual migration of routers that can understand and parse 4-octet ASN numbers.

### 6.1.3.11 AIGP metric attribute

The accumulated IGP (AIGP) metric attribute is an optional non-transitive attribute that can be attached to selected routes (using route policies) in order to influence the BGP decision process to prefer BGP paths with a lower end-to-end IGP cost, even when the compared paths span more than one AS or IGP instance. AIGP is different from MED in several important ways.

- AIGP is not intended to be transitive between completely distinct ASs (only across internal AS boundaries).
- AIGP is always compared in paths that have the attribute, regardless of whether they come from different neighbor ASs.
- AIGP is more important than MED in the BGP decision process.
- AIGP is automatically incremented every time there is a BGP next-hop change, so that it can track the end-to-end IGP cost. All arithmetic operations on MED attributes must be done manually (for example, using route policies).

The 7705 SAR supports AIGP for the following address families in the GRT context:

- IPv4
- label-IPv4
- IPv6

The AIGP attribute is only sent to peers that are configured with the **aigp** command. If the attribute is received from a peer that is not configured for **aigp**, or if the attribute is received in an unsupported route type, the attribute is discarded and is not propagated to other peers. However, it is still displayed in BGP **show** commands.

When a 7705 SAR receives a route with an AIGP attribute and readvertises the route to an AIGP-enabled peer without any change to the BGP next hop, the AIGP metric value is unchanged by the advertisement (RIB-OUT) process. However, if the route is readvertised with a new BGP next hop, the AIGP metric value



is automatically incremented by the route table cost (or tunnel table cost) to reach the received BGP next hop and/or is incremented by a statically configured value (using route policies).

## 6.1.4 Multiprotocol BGP attributes

Multiprotocol BGP attributes (MP-BGP) allow BGP peers to exchange routes for NLRI other than IPv4 prefixes; for example, IPv6 prefixes, Layer 3 VPN routes, Layer 2 VPN routes, and flow-spec rules. A BGP router that supports MP-BGP indicates the types of routes it wants to exchange with a peer by including the corresponding AFI (Address Family Identifier) and SAFI (Subsequent Address Family Identifier) values in the MP-BGP capability of its OPEN message. The two peers forming a session do not need indicate support for the same address families; as long as there is one AFI/SAFI in common the session will establish and routes associated with all the common AFI/SAFI can be exchanged between the peers.

The list of AFI/SAFI advertised in the MP-BGP capability is controlled entirely by the **family** commands. The AFI/SAFI supported by the 7705 SAR and the method of configuring the AFI/SAFI support is summarized in the following table.

Table 82: Multiprotocol BGP support on the 7705 SAR

Name	AFI	SAFI	Configuration commands
IPv4 unicast	1	1	<b>family ipv4</b>
IPv4 labeled unicast	1	4	<b>family label-ipv4</b>
NG-MVPN IPv4	1	5	<b>family mvpn-ipv4</b>
VPN-IPv4	1	128	<b>family vpn-ipv4</b>
RT constrain	1	132	<b>family route-target</b>
IPv6 unicast	2	1	<b>family ipv6</b>
IPv6 labeled unicast	1	4	<b>family label-ipv6</b>
VPN-IPv6	2	128	<b>family vpn-ipv6</b>
BGP-LS	16388 (base) 16388 (VPN)	71 (base) 128 (VPN)	<b>family bgp-ls</b>

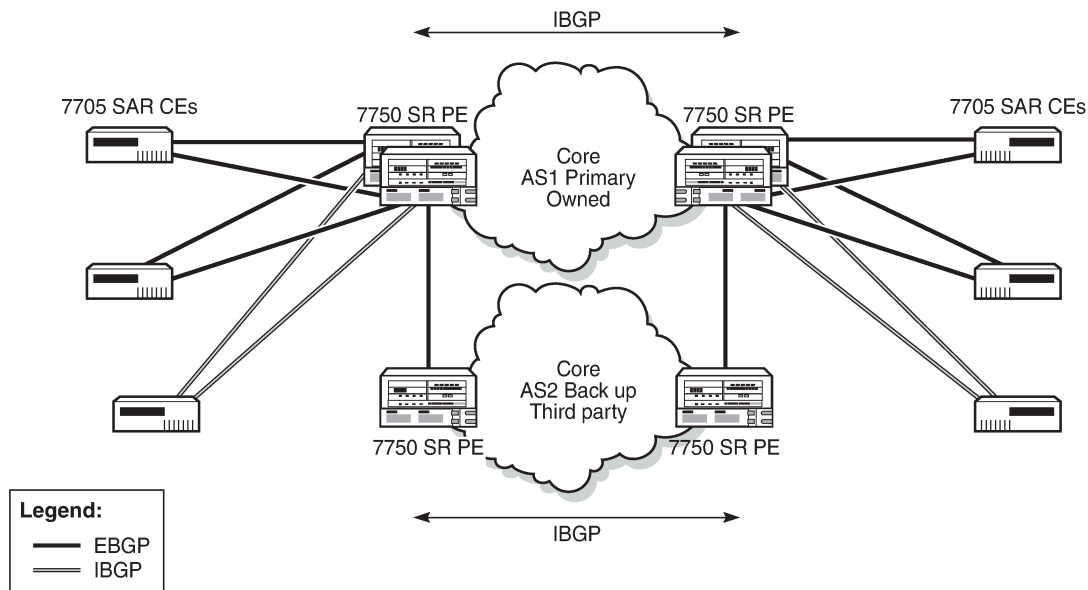
To advertise reachable routes of a particular AFI/SAFI a BGP router includes a single MP\_REACH\_NLRI attribute in the UPDATE message. The MP\_REACH\_NLRI attribute encodes the AFI, the SAFI, the BGP next-hop and all the reachable NLRI. To withdraw routes of a particular AFI/SAFI a BGP router includes a single MP\_UNREACH\_NLRI attribute in the UPDATE message. The MP\_UNREACH\_NLRI attribute encodes the AFI, the SAFI and all the withdrawn NLRI. While it is valid to advertise and withdraw IPv4 unicast routes using the MP\_REACH\_NLRI and MP\_UNREACH\_NLRI attributes, 7705 SAR always uses the IPv4 fields of the UPDATE message to convey reachable and unreachable IPv4 unicast routes.

### 6.1.5 BGPv6

The 7705 SAR supports BGPv6 in the GRT (for network and IES interfaces) to provide increased IPv6 connectivity in a PE-CE environment.

The following figure shows an example of a network with 7705 SAR nodes on the CE utilizing BGPv6. The 7705 SAR can also be used on the PE.

Figure 39: BGPv6



26598

CEs are connected via EBGP or, in some cases, IBGP to edge routers, which then connect the CEs across a core BGP network. A privately owned customer network uses IBGP by default. For backup, a third-party network that uses EBGP for connectivity between edge routers and the backup network is used.

Any failures occurring between PEs and CEs are detected with BFD and BGP PIC and resolved with BGP fast reroute.

### 6.1.6 BGP add-paths

The add-paths function allows a BGP router to advertise multiple distinct paths for the same prefix/ NLRI. BGP add-paths provides a number of potential benefits, including reduced routing churn, faster convergence, and better load sharing. See *draft-ietf-idr-add-paths-04, Advertisement of Multiple Paths in BGP* for details of the add-paths capabilities advertisement.

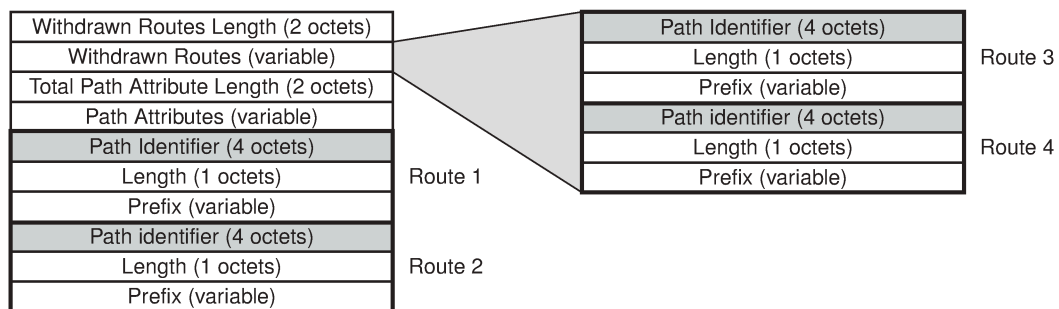
This section also contains information about the following topics:

- [Path selection mode and parameters for multiple paths to add-path peers](#)
- [Routing policy for multiple paths](#)
- [BGP route advertisement rules for multiple paths](#)
- [BGP split horizon](#)

In order for router A to receive multiple paths per NLRI from peer B for a particular address family, they must advertise their BGP capabilities during session setup. Peer router B advertises that it wants to send multiple paths for an address family and router A indicates that it is able to receive multiple paths for the address family.

When the add-paths receive capability for an address family has been negotiated with a peer router, all advertisements and withdrawals of NLRI within that address family by that peer will include a path identifier. Path identifiers have no significance to the receiving peer. If the combination of NLRI and path identifier in an advertisement from a peer is unique and does not match an existing route in the RIB-IN from that peer, then the route is added to the RIB-IN. If the combination of NLRI and path identifier in a received advertisement is the same as an existing route in the RIB-IN from the peer, then the new route replaces the existing one. If the combination of NLRI and path identifier in a received withdrawal matches an existing route in the RIB-IN from the peer, that route is removed from the RIB-IN. An UPDATE message carrying an IPv4 NLRI with a path identifier is shown in the following figure.

Figure 40: BGP update message with path identifier for IPv4 NLRI



24075

Add-paths are only supported on the base router BGP instance and the EBGP and IBGP sessions it forms with other add-path-capable peers. The ability to send and receive multiple paths per prefix to and from an add-paths peer is configurable per family. The following families support BGP add-path:

- IPv4
- label-IPv4
- VPN-IPv4
- IPv6
- VPN-IPv6

### 6.1.6.1 Path selection mode and parameters for multiple paths to add-path peers

The RIB-IN may have multiple paths for a prefix (for example, prefix D). The path selection mode refers to the algorithm used to decide which of these paths to advertise to an add-paths peer. In the current implementation, the 7705 SAR supports only one path selection algorithm, the Add-N algorithm described in *draft-ietf-idr-add-paths-guidelines-00, Best Practices for Advertisement of Multiple Paths in BGP*. The Add-N algorithm selects the N best overall paths for each prefix, regardless of path type (internal vs. external), degree of difference between the paths or use in forwarding. If this set of N best overall paths includes multiple paths with the same BGP NEXT\_HOP, only the best route with a particular NEXT\_HOP is advertised and the others are suppressed.

In the 7705 SAR implementation, N is configurable, per address-family, at the BGP global, group, and neighbor levels; N has a minimum value of 1 and a maximum value of 16. For a peer belonging to a group, the path selection parameters are first based on the neighbor configuration for the peer, then the group configuration, then the BGP global configuration.

When **add-paths** is enabled for the VPN-IPv4 or VPN-IPv6 address family in the base router BGP context, only VPN-IP routes in the base router BGP RIB-IN are considered for advertisement to add-path peers. If a VPRN best route to a destination is a BGP-VPN route imported from the base router and its next-best route is a CE-learned BGP route that would be accepted by the VPRN VRF export policy, this next-best route is not advertised, regardless of the base router's add-path configuration.

### 6.1.6.2 Routing policy for multiple paths

BGP and VRF export policies are applied after path selection is performed. If add-paths is configured to send up to N paths to a peer and an export policy prevents some number (X) of the N best paths for prefix D from being advertised to the peer, then only the remaining (N minus X) best paths are sent.

### 6.1.6.3 BGP route advertisement rules for multiple paths

Add-paths allows non-best paths to be advertised to a peer, but it still complies with basic BGP advertisement rules such as the IBGP split horizon rule: a route learned from an IBGP neighbor cannot be readvertised to another IBGP neighbor unless the router is configured as a route reflector.

If add-paths is configured to send up to N paths to a peer and some number (X) of the N best paths for D cannot be advertised to the peer due to route advertisement rules, then only the remaining (N minus X) routes are advertised.

### 6.1.6.4 BGP split horizon

Split horizon refers to the action taken by a router to avoid advertising a route back to the peer from which it was received or to another non-client peer for IBGP. By default, the 7705 SAR applies split-horizon behavior only to routes received from IBGP non-client peers. This split-horizon functionality, which cannot be disabled, prevents routing loops by disabling the advertisement of routes learned from a non-client IBGP peer back to the sending peer or any other non-client peer.

To apply split-horizon behavior to routes learned from RR clients, peers or EBGP peers, the **split-horizon** command must be configured in the appropriate contexts; it is supported at the global BGP, group, and neighbor levels. When split horizon is enabled on these types of sessions, it only prevents the advertisement of a route back to its originating peer; for example, the 7705 SAR does not prevent the advertisement of a route learned from one EBGP peer back to a different EBGP peer in the same neighbor AS.

## 6.1.7 Outbound route filtering (ORF)

ORF is a mechanism that allows one router, the ORF-sending router, to signal to a peer, the ORF-receiving router, a set of route filtering rules (ORF entries) that the ORF-receiving router should apply to its route advertisements toward the ORF-sending router. The ORF entries are encoded in Route Refresh messages.

The use of ORF for a session must be negotiated—both routers must advertise the ORF capability in their Open messages. The ORF capability describes the address families that support ORF, and for each address family, the ORF types that are supported and the ability to send/receive each type. The 7705 SAR supports ORF type 3, ORF based on extended communities, for the following address families:

- VPN-IPv4
- VPN-IPv6
- MVPN-IPv4

The send and receive capability for ORF is configurable with the **send-orf** and **accept-orf** commands, and the setting applies to all supported address families.

ORF type 3 allows a PE router that imports VPN routes with a particular set of route target extended communities to indicate to a peer (for example a route reflector) that it only wants to receive VPN routes that contain one or more of these extended communities. To inform a peer to add or remove a route target extended community, the PE router sends a Route Refresh message to the peer containing an ORF type 3 entry that instructs the peer to either add or remove a permit entry for the 8-byte extended community value.

The type 3 ORF entries that are sent to a peer can be generated dynamically (if no route target extended communities are specified with the **send-orf** command) or specified statically. Dynamically generated ORF entries are based on the route targets that are imported by all locally configured VPRNs.

A router that has installed ORF entries received from a peer can still apply BGP export policies to the session. BGP export policies overrule ORF entries. If the evaluation of a BGP export policy results in a reject action for a VPN route that matches a permit ORF entry, the route is not advertised.

ORF filtering is efficient; a large number of VPN routes can be filtered faster than using a conventional BGP export policy. In addition to ORF, users can also use [BGP route target constrained route distribution](#) for dynamic filtering based on route target extended communities. RTC, as discussed below, offers some advantages over ORF.

## 6.1.8 BGP route target constrained route distribution

BGP route target constrained route distribution allows a router to advertise a route target constraint (RTC) route to its peers. A peer receiving an RTC route does not advertise VPN routes back to the router unless they contain a route target extended community that matches one of the received RTC routes. For detailed information about RTC, see the 7705 SAR Services Guide, "Route Target Constraint".

RTC routes are carried using MP-BGP with an AFI value of 1 and SAFI value of 132. The NLRI of an RTC route encodes an Origin AS and a route target extended community using prefix-type encoding with the host bits after the prefix length set to zero.

In order for two routers to exchange route target membership NLRI, they must advertise the corresponding AFI and SAFI to each other during capability negotiation. The use of MP-BGP means route target membership NLRI are propagated, loop-free, within an autonomous system and between autonomous systems, using well-known BGP route selection and advertisement rules.

If there are multiple RTC routes for the same NLRI, the BGP decision process selects one as the best path. The propagation of the best path installs RIB-Out filter rules as it travels from one router to the next, which creates an optimal VPN route distribution tree rooted at the source of the RTC route.

Route target constrained route distribution and outbound route filtering (ORF) both allow routers to advertise which route target extended communities they want to receive in VPN routes from peers. RTC,

however, is more widely supported, is simpler to configure, and its distribution scope is not limited to a direct peer.

ORF and RTC are mutually exclusive for a particular BGP session. The CLI does not attempt to block the configuration of both ORF and RTC, but if both capabilities are enabled for a session, the ORF capability will not be included in the Open message sent to the peer.

The capability to exchange RTC routes is advertised when the **route-target** keyword is added to the **family** command. RTC is supported for EBGP and IBGP sessions on the base router instance.

When RTC has been negotiated with one or more peers, the 7705 SAR automatically originates and advertises to these peers one RTC route with a prefix length of 96 (the origin AS and route target extended community are fully specified) for every route target imported by a locally configured VPRN or BGP-based Layer 2 VPN, including MVPN-specific route targets.

A router may be configured to send the default RTC route to a group or neighbor with the **default-route-target** CLI command. This causes the router to generate and send a special RTC route with a prefix length of 0:0:0/0. Sending the default RTC route to a peer conveys a request to receive all VPN routes from that peer. The default RTC route is typically advertised by a route reflector to PE clients. Advertising the default RTC route to a peer does not suppress other more specific RTC routes from being sent to that peer. A received default RTC route is never propagated to other routers.

The advertisement of RTC routes by a route reflector follows special rules as described in RFC 4684. These rules are needed to ensure that RTC routes for the same NLRI that are originated by different PE routers in the same AS are properly distributed within the AS.

When a BGP session comes up and RTC is enabled for the session (both peers advertised the MP-BGP capability), routers delay sending any VPN-IPv4 and VPN-IPv6 routes until either the session has been up for 60 s or the end-of-RIB marker is received for the RTC address family. When the VPN-IPv4 and VPN-IPv6 routes are sent, they are filtered to include only those with a route target extended community that matches an RTC route from the peer.

VPN-IP routes matching an RTC route originated in the local AS are advertised to any IBGP peer that advertises a valid path for the RTC NLRI. Route distribution is not limited only to the IBGP peer advertising the best path. VPN-IP routes matching an RTC route that originated outside the local AS are only advertised to the EBGP or IBGP peer that advertises the best path.

The 7705 SAR does not support an equivalent of BGP multipath for RTC routes. There is no way to distribute VPN routes across more than one set of inter-AS paths that are nearly equal.

Received RTC routes have no effect on the advertisement on MVPN-IPv4 routes.

## 6.2 Group configuration and peers

To enable BGP routing, participating routers must have BGP enabled and be assigned to an autonomous system, and the neighbor (peer) relationships must be specified. A router can belong to only one AS. TCP connections must be established in order for neighbors to exchange routing information and updates. Neighbors exchange BGP Open messages that include information such as AS numbers, BGP versions, router IDs, and hold-time values. Keepalive messages determine if a connection is established and operational. The hold-time value specifies the maximum time BGP will wait between successive messages (either Keepalive or Update) from its peer, before closing the connection.

In BGP, peers are arranged into groups. A group must contain at least one neighbor. A neighbor must belong to a group. Groups allow multiple peers to share similar configuration attributes.

Although neighbors do not have to belong to the same AS, they must be able to communicate with each other. If TCP connections are not established between two neighbors, the BGP peering session will not be established and updates will not be exchanged.

Peer relationships are defined by configuring the IP address of the routers that are peers of the local BGP domain. When neighbor and peer relationships are configured, the BGP peers exchange Update messages to advertise network reachability information.

The 7705 SAR supports BGP peering sessions to both static and dynamic neighbors.

This section contains information about the following topics:

- [Hierarchical levels](#)
- [Route reflection](#)
- [BGP peer groups with dynamic neighbors](#)
- [Fast external failover](#)
- [BGP fast reroute with prefix-independent convergence](#)
- [Calculating backup paths](#)
- [Sending of BGP communities](#)
- [BGP decision process](#)

### 6.2.1 Hierarchical levels

BGP parameters are initially applied at the global level. These parameters are inherited by the group and neighbor (peer) levels. Parameters can be modified and overridden on a level-specific basis. BGP command hierarchy consists of three levels:

- global level
- group level
- neighbor level

Many of the hierarchical BGP commands can be modified at different levels. The most specific value is used. That is, a BGP group-specific command takes precedence over a global BGP command. A neighbor-specific command takes precedence over a global BGP and group-specific command; for example, if you modify a BGP neighbor-level command default, the new value takes precedence over group- and global-level settings.



**Caution:** Take care how you use command settings at a lower level that can disable features at a higher level. For example, if the **damping** command is used to enable damping at the global level and you want it disabled only for a specified neighbor, use the **no damping** command at the neighbor level only; do not use it the global level also because this will disable damping for all neighbors within the BGP global instance.

### 6.2.2 Route reflection

In a standard BGP configuration, all BGP speakers within an AS must have full BGP mesh to ensure that all externally learned routes are redistributed through the entire AS. IBGP speakers do not readvertise routes learned from one IBGP peer to another IBGP peer. If a network grows, scaling issues could emerge



because of the full mesh configuration requirement. Instead of peering with all other IBGP routers in the network, each IBGP router only peers with a router configured as a route reflector.

Route reflection circumvents the full mesh requirement but maintains the full distribution of external routing information within an AS. Route reflection is effective in large networks because it is manageable, scalable, and easy to implement. Route reflection is implemented in autonomous systems with a large internal BGP mesh in order to reduce the number of IBGP sessions required within an AS.

A large AS can be subdivided into smaller ASs, called clusters. Each cluster contains at least one route reflector, which is responsible for redistributing route updates to all clients. Route reflector clients do not need to maintain a full peering mesh between each other. They only require a peering to the route reflectors in their cluster. The route reflectors must maintain a full peering mesh between all non-clients within the AS.

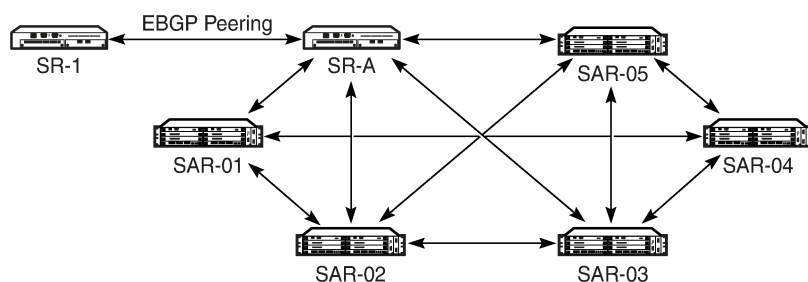
Each route reflector must be assigned a cluster ID and specify which neighbors are clients and which are non-clients to determine which neighbors should receive reflected routes and which should be treated as a standard IBGP peer. Additional configuration is not required for the route reflector, aside from the typical BGP neighbor parameters.

BGP speakers within the AS that are not peers with the route reflector are called non-clients. Non-clients are peers to a route reflector but do not understand the route reflector attributes. Several BGP-speaking routers can peer with a route reflector. A route reflector forms peer connections to other route reflectors.

The following figure displays a simple configuration with several IBGP 7705 SAR nodes.

When SR-A receives a route from SR-1 (an external neighbor), it must advertise route information to SAR-01, SAR-02, SAR-03, SAR-04, and SAR-05. To prevent loops, IBGP learned routes are not readvertised to other IBGP peers.

*Figure 41: Fully meshed BGP configuration*



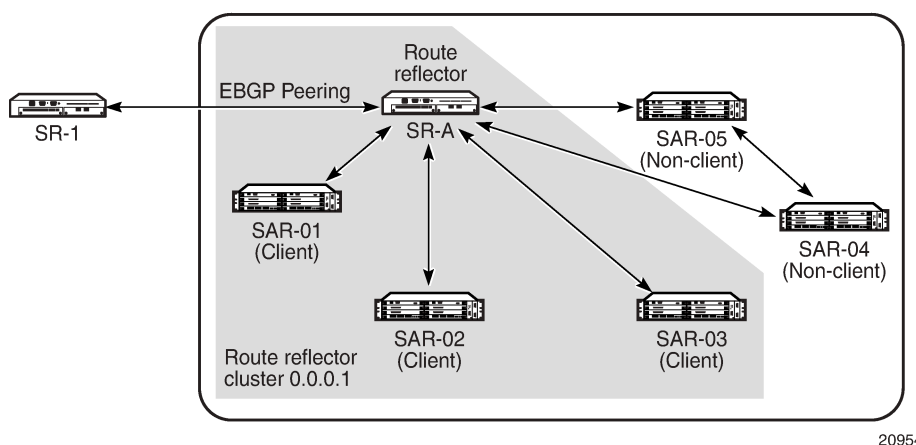
20953

When route reflectors are configured, the routers within a cluster do not need to be fully meshed. [Figure 41: Fully meshed BGP configuration](#) depicts a fully meshed network and [Figure 42: BGP configuration with route reflectors](#) depicts the same network but with route reflectors configured to minimize the IBGP mesh between SR-A, SAR-01, SAR-02, and SAR-03. SR-A, configured as the route reflector, is responsible for redistributing route updates to clients SAR-01, SAR-02, and SAR-03. IBGP peering between SAR-01, SAR-02 and SAR-03 is not necessary because even IBGP learned routes are reflected to the route reflector's clients.

In the following figure, SAR-04 and SAR-05 are shown as non-clients of the route reflector. As a result, a full mesh of IBGP peerings must be maintained between SR-A, SAR-04, and SAR-05.



Figure 42: BGP configuration with route reflectors



20954

BGP speakers within an AS that are not configured as reflectors are considered to be client peers. Non-client peers are other routers in the AS. A route reflector enables communication between the clients and non-client peers. Route reflector-to-client peer configurations do not need to be fully meshed, but non-client peers need to be fully meshed within an AS.

A grouping, called a cluster, is composed of a route reflector and its client peers. A cluster ID identifies the grouping unless specific BGP peerings are configured. A cluster's clients do not share information messages with other peers outside the cluster. Multiple route reflectors can be configured within a cluster for redundancy. A router assumes the role as a route reflector by configuring the **cluster cluster-id** command. No other command is required unless the operator wants to disable reflection to specific clients.

When a route reflector receives an advertised route, depending on the sender and neighbors (peers), it selects the best path. Routes received from an EBGP peer are advertised unmodified (to retain next-hop information) to all clients and non-client peers in the AS. Routes received from a non-client peer are advertised to all clients in the AS. Routes received from a client are advertised to all clients and non-client peers.

### 6.2.3 BGP peer groups with dynamic neighbors

The 7705 SAR supports TCP connections to statically configured and dynamic (unconfigured) BGP peers. A static TCP connection with a remote peer requires the peer to be locally configured as a neighbor using the **neighbor ip-address** command. Dynamic TCP connections, which are optional and in addition to static connections, use the **dynamic-neighbor prefix** command to establish a prefix range of potential neighbors from which dynamic connections are allowed, as per RFC 4271 for a BGP speaker.

Enabling the dynamic neighbor functionality makes a BGP speaker more vulnerable to certain security threats and configuration errors; however, on an internal node such as a route reflector these risks may be tolerable, especially if many manual BGP neighbor configurations can be avoided.

The implementation of BGP peer groups with dynamic neighbors is as follows:

- a configured BGP group supports both static and dynamic peers
- multiple IPv4 and/or IPv6 prefix ranges can be associated with a peer group to specify allowed sources for incoming TCP connections

The association of a dynamic peer with a group is based on the source IP address of the TCP connection. If there are multiple overlapping IP prefixes that match the remote IP address, the IP prefix with the longest prefix length is used.

- outgoing TCP connections are never initiated toward discovered dynamic peers
- all dynamic peers in a group must use the same session parameters; the parameter values come from the group configuration (such as hold time, keepalive, peer AS, and advertised address families)
- the maximum number of dynamic peers is configurable per group as well as for the entire BGP instance using the **dynamic-neighbor-limit** command
- dynamic peers are supported by the base router and VPRN BGP instances

#### 6.2.4 Fast external failover

Fast external failover on a group and neighbor basis is supported. For EBGP neighbors, fast external failover controls whether the router drops an EBGP session immediately upon an interface-down event, or whether the BGP session is kept up until the hold-time expires.

When fast external failover is disabled, the EBGP session stays up until the hold-time expires or the interface comes back up again. If the BGP routes become unreachable as a result of the interface going down, they are immediately withdrawn from other peers.

#### 6.2.5 BGP fast reroute with prefix-independent convergence

BGP fast reroute (FRR) creates an alternate path to support fast rerouting of BGP traffic around failed or unreachable next hops. When BGP FRR is enabled, the system switches to a precalculated alternate path as soon as a failure is detected.

BGP Prefix-Independent Convergence (PIC) is supported on the 7705 SAR and is automatically enabled when a BGP backup path is enabled. With BGP FRR and PIC, alternate paths are precalculated and the FIB is updated with all alternate next hops. When a prefix has a backup path, and its primary paths fail, the affected traffic is rapidly diverted to the backup path without waiting for control plane reconvergence to occur. When many prefixes share the same primary paths, and in some cases also share the same backup path, the time to switch traffic to the backup path can be very fast and is independent of the number of prefixes.

BGP FRR can be enabled in the BGP context or in the VPRN context on either IPv4 or IPv6 prefixes. For information about BGP FRR for VPRNs, see the 7705 SAR Services Guide, "BGP Fast Reroute with Prefix-Independent Convergence in a VPRN".

When BGP FRR is enabled, the control plane attempts to find an eligible backup path for every received IPv4 or IPv6 prefix. In most cases, the backup path is the single best path remaining after the 7705 SAR removes the primary ECMP paths and any paths with the same BGP next hops.

The following scenarios affect backup path selection:

- A backup path is not calculated for a prefix if the best path is a label-IPv4 route that has been programmed with multiple ECMP next hops through different BGP next hops.
- For label-IPv4 or prefixes that are readvertised with a new BGP next hop, the programmed backup path is the same for all prefixes that have the same best path and received label, even if the calculated backup path is different for some of the prefixes.

The following table lists the supported BGP FRR scenarios.

Table 83: BGP FRR scenarios

Ingress packet	Primary route	Backup route	PIC
IPv4 (ingress PE)	IPv4 route with next hop A resolved by an IPv4 route	IPv4 route with next hop B resolved by an IPv4 route	Yes
IPv4 (ingress PE)	VPN-IPv4 route with next hop A resolved by a GRE, LDP, RSVP, or BGP tunnel	VPN-IPv4 route with next hop B resolved by a GRE, LDP, RSVP or BGP tunnel	Yes
IPv6 (ingress PE)	VPN-IPv6 route with next hop A resolved by a GRE, LDP, RSVP, or BGP tunnel	VPN-IPv6 route with next hop B resolved by a GRE, LDP, RSVP, or BGP tunnel	Yes
IPv6 (ingress PE)	IPv6 route with next hop A resolved by an IPv6 route	IPv6 route with next hop B resolved by an IPv6 route	Yes
MPLS (egress PE)	IPv4 route with next hop A resolved by an IPv4 route	IPv4 route with next hop B resolved by an IPv4 route	Yes
MPLS (egress PE)	IPv4 route with next hop A resolved by an IPv4 route	VPN-IPv4 route with next hop B resolved by a GRE, LDP, RSVP or BGP tunnel	Yes
MPLS (egress PE)	IPv6 route with next hop A resolved by an IPv6 route	VPN-IPv6 route with next hop B resolved by a GRE, LDP, RSVP or BGP tunnel	Yes

### 6.2.5.1 BGP FRR failure detection and switchover

When BGP FRR is enabled, the 7705 SAR reroutes traffic onto a backup path based on input from BGP. When a primary path is no longer usable, BGP notifies the IOM and affected traffic is immediately switched to the backup path.

BGP FRR is triggered when:

- peer tracking is enabled and a peer IP address is unreachable
- a BFD session associated with the BGP peer goes down
- a BGP session with a peer is terminated
- there is no longer any route allowed by the next-hop resolution policy, if configured, that can resolve the BGP next-hop address
- the LDP tunnel that resolves the next-hop is down. This can occur if there is no longer any IP route that can resolve the FEC, if the LDP session goes down, or if the LDP peer withdraws its label mapping.
- the RSVP tunnel that resolves the next hop is down. This can occur if a ResvTear message is received, the RESV state times out, or if the outgoing interface fails and is not protected by FRR or a secondary path.
- the BGP tunnel that resolves the next hop is down. This can occur if the BGP label-IPv4 route is withdrawn by the peer or if it becomes invalid due to an unresolved next hop.

## 6.2.6 Calculating backup paths

Fast reroute is enabled using the BGP **backup-path** command.

The **backup-path** command in the base router context is used to control fast reroute on a per-RIB basis (IPv4, label-IPv4, and IPv6). When the command specifies a particular family, BGP attempts to find a backup path for every prefix learned by the associated BGP RIB.

In general, a prefix supports ECMP paths or a backup path, but not both. The backup path is the best path after the primary path and any paths with the same BGP next hop as the primary path have been removed.

## 6.2.7 Sending of BGP communities

The capability to explicitly enable or disable the sending of the BGP community attribute to BGP neighbors, other than through the use of policy statements, is supported.

This feature allows an administrator to enable or disable the sending of BGP communities to an associated peer. This feature overrides communities that are already associated with a given route or that may have been added via an export route policy. In other words, even if the export policies leave BGP communities attached to a given route, when the **disable-communities** feature is enabled, no BGP communities are advertised to the associated BGP peers.

## 6.2.8 BGP decision process

When a BGP router has multiple routes in its RIB-IN, the BGP decision process is responsible for deciding which route is the best. The best path can be used by the local router and advertised to other BGP peers.

Whenever a new route is received, the BGP decision process compares this route to the current best path for the same prefix by making a series of comparisons. The process is used to determine whether the new route should become the new best path.

On the 7705 SAR, the BGP decision process prioritizes received routes based on the following sequence of comparisons. If there is a tie between routes at any step, BGP proceeds to the next step:

1. Select a valid route over an invalid route.
2. Select the route with the numerically lowest route-table preference.
3. Select the route with the highest local preference (LOCAL\_PREF).
4. Select the route with an AIGP metric. If both routes have an AIGP metric, select the route with the lowest sum of:
  - a. the AIGP metric value stored with the RIB-IN copy of the route
  - b. the route table or tunnel table cost between the calculating router and the BGP next hop in the received route
5. Select the route with the shortest AS path. This step is skipped if **as-path-ignore** is configured for the address family.
6. Select the route with the lowest ORIGIN (IGP < EGP < Incomplete).
7. Select the route with the lowest MED. Routes with no MED attribute (default MED value of 0) are exempted from this step unless **always-compare-med** is configured.
8. Select the route learned from an EBGP peer over a route learned from an IBGP peer.

9. Select the route with the lowest IGP cost to the next hop.
10. Select the route with the lowest BGP identifier.
11. Select the route with the shortest CLUSTER\_LIST length.
12. Select the route with the lowest next-hop IP address.

## 6.3 BGP route tunnels

BGP route tunnels can be used to distribute MPLS label mapping information for a particular route, as defined in RFC 3107. When BGP is used to distribute a route, it can also distribute the MPLS label for the same route by piggybacking the label onto the BGP update message.

In a network scenario where two adjacent LSRs are also BGP peers, label distribution can be handled entirely by the BGP update message—no other distribution protocol is required.

In a network scenario where the exterior LSRs are BGP speakers, the LSRs can send MPLS labels to each other along with each route they distribute. The MPLS label is piggybacked onto the BGP update message by using the BGP-4 Multiprotocol Extensions Attribute. The label is encoded in the NLRI field and the SAFI field is used to indicate that the NLRI field contains a label. A labeled route update is only exchanged between BGP speakers supporting AFI/SAFI for MPLS Label Capability.

The 7705 SAR supports the following BGP address families:

- IPv4
- VPN-IPv4
- IPv6
- VPN-IPv6
- MVPN-IPv4
- route-target
- EVPN
- label-IPv4
- label-IPv6
- BGP-LS

The types of routes that are advertised are indicated by the AFI/SAFI advertised.

BGP speakers that are not adjacent to each other may choose LDP or RSVP-TE tunnels to reach the BGP labeled route next hop. Client applications using BGP tunnels must push two labels (BGP label and LDP/RSVP-TE label) on top of the existing label stack (which will typically include one or more service-specific labels) in order to reach the BGP next hop. The next-hop BGP node can either resolve its own local LDP or RSVP-TE LSPs to reach its next hop.

If BGP speaker nodes are adjacent to each other (for example, ASBRs running an EBGP session) and have exchanged labeled routes, then only the BGP route label is used to forward traffic toward the next hop. If the BGP route tunnel transits through multiple autonomous systems, then each AS segment would have two labels. For the last BGP segment, ASBR may select to have either one (LDP/RSVP-TE) or two (BGP + LDP/RSVP-TE) labels to reach the far end.

This section contains information about the following topics:

- [Route reflector next-hop-self for IP-VPNv4/6 routes over IPv4 LU](#)

- [Layer 2 services and BGP route tunnel](#)
- [BGP route tunnel SDP binding](#)
- [BGP route tunnel with multihop EBGP resolution](#)
- [Next-hop resolution of BGP labeled routes to tunnels](#)
- [BGP next-hop resolution and peer tracking](#)
- [BGP route installation in the route table](#)
- [BGP link state](#)

### 6.3.1 Route reflector next-hop-self for IP-VPNv4/6 routes over IPv4 LU

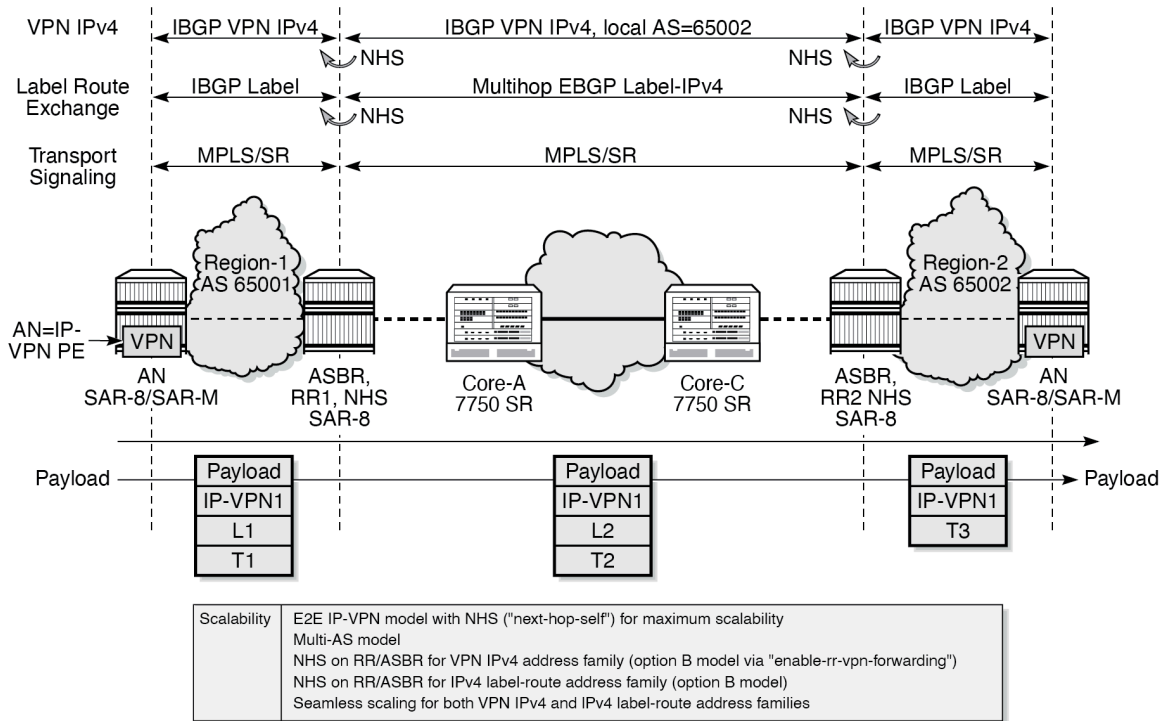
As an enhancement to the preceding route distribution scenario, inter-AS option B model-like behavior (as per RFC 4364, *BGP/MPLS IP Virtual Private Networks (VPNs)*) can be enabled for route reflectors that exchange PE reachability information using IPv4 address family labeled routes. A route reflector acting as an ASBR that receives VPN IPv4 or VPN IPv6 routes from a client over a BGP-labeled tunnel can use next-hop-self to redistribute the VPN routes to another ASBR by means of an IBGP session for the VPN IPv4 or VPN IPv6 address family.

For example (see [Figure 43: Route reflector next-hop-self for VPN IPv4 routes over IPv4 labeled routes](#)):

- a route reflector (RR1), acting as an ASBR in AS 65001, receives VPN IPv4 routes from PE1 over a BGP-labeled tunnel
- a route reflector (RR2), acting as an ASBR in AS 65002, receives VPN IPv4 routes from PE2 over a BGP-labeled tunnel
- the **enable-rr-vpn-forwarding** command is enabled on RR1, which allows it to distribute VPN IPv4 routes
- the **next-hop-self** command is enabled on both RR1 and RR2
- RR1 has an IBGP session established with RR2. To establish the IBGP session, RR1 must have a local-AS value configured as AS 65002.

When PE2 advertises a VPN IPv4 route to RR2, the route reflector resolves the route to an MPLS tunnel, changes the next hop to itself, advertises the route to RR1, and performs a label swap between the advertised and received labels. RR1 resolves the route via the IPv4 tunnel to RR2. RR1 then changes the next hop to itself, performs a label swap, prepends the local-AS 65002, and readvertises the VPN IPv4 route to PE1.

Figure 43: Route reflector next-hop-self for VPN IPv4 routes over IPv4 labeled routes



24661

### 6.3.2 BGP labeled unicast selective download

The number of BGP labeled unicast (BGP-LU) IPv4 routes that are distributed in the control plane can overwhelm the TTM and LTN tables. The BGP-LU selective download feature solves this problem without the need to configure import policies. When the **selective-label-ipv4-install** command is configured, learned BGP-LU routes are installed in the control plane but only downloaded to the RTM and TTM if they are required. If a local Layer 2 or Layer 3 service resolves to a BGP-LU route, the routes are downloaded to the TTM and LTN tables. Similarly, for BGP shortcuts, the TTM and RTM are only populated when the TTM resolves to a BGP-LU tunnel.

The **selective-label-ipv4-install** command can be configured in the BGP context of the base router: in the global BGP context, the group context, or the neighbor context.

When the **selective-label-ipv4-install** command is configured in the BGP context of the base router, BGP-LU IPv4 routes in the RIB-IN are made invalid if they are received from a base router BGP peer and are not required by any eligible service. The following table shows the logic used by the 7705 SAR to determine when a route is required and will not be marked invalid.

Table 84: BGP-LU selective download logic by service type

Service type	Logic
Layer 2 services with user-provisioned SDPs	If a Layer 2 service with a user-provisioned SDP specifies <b>bgp-tunnel</b> as the transport, BGP-LU



Service type	Logic
	IPv4/32 routes matching the SDP far end will not be marked invalid regardless of the operational state of the SDP.
Layer 2 services with EVPN endpoints	If a Layer 2 service imports a BGP-EVPN route, BGP-LU IPv4/32 routes matching the next-hop address of this route will not be marked invalid.
VPRN with explicitly configured SDP	If a VPRN service has a configured SDP, BGP-LU IPv4 routes matching the SDP far-end address will not be marked as invalid, regardless of the operational state of the SDP.
VPRN with auto-bind tunnel	If an auto-bind VPRN service imports a VPN-IPv4 or VPN-IPv6 route where the BGP next hop matches a BGP-LU IPv4 route, that route will not be marked as invalid, regardless of whether the auto-bind tunnel resolution filter allows BGP tunnels.
IP-VPN next-hop-self route reflector	If the base router BGP instance is configured as a next-hop-self route reflector, BGP-LU IPv4 routes matching any IPv4 address in the BGP next-hop field of any received label-IPv4 or IPv6 route will not be marked invalid, regardless of whether the transport-tunnel resolution filter allows BGP tunnels.

When a BGP-LU IPv4 route is invalid in the RIB-IN, the BGP decision process prefers any valid route over this route, and the invalid BGP-LU IPv4 route will not be programmed as a next hop (primary next hop, ECMP next hop, or backup next hop) of any IP route or tunnel.

When a BGP-LU IPv4 route is invalid in the RIB-IN, it is marked with the flag LABEL\_UNICAST\_NO\_SVC and the invalid route is handled as follows:

- no route for the IPv4 prefix is added to the route table from the BGP-LU RIB
- no BGP tunnel for the IPv4 /32 IPv4 prefix is added to the tunnel table
- no RIB-OUT is generated for the invalid BGP-LU route; therefore this invalid route does not trigger a label-swap (ILM) entry to be programmed



**Note:** Configuring the **selective-label-ipv4-install** command for a BGP unconditionally invalidates all non-IPv4/32 BGP-LU routes received on that session because those routes are never used to resolve service endpoints.

### 6.3.3 Layer 2 services and BGP route tunnel

An MPLS transport tunnel per VPLS/VLL instance is enabled by an explicit MPLS-SDP configuration for each far-end PE.



### 6.3.4 BGP route tunnel SDP binding

BGP route tunnel-based SDP binding is allowed for VPLS and VLL services. Any service using BGP SDP must presume a two-label stack to compute the SDP MTU. For more information about SDPs for BGP route tunnels, see the 7705 SAR Services Guide, "Service Destination Points (SDPs)".

### 6.3.5 BGP route tunnel with multihop EBGP resolution

Either an RSVP-TE or LDP LSP can be used to resolve the next hop between two ASBR nodes. The **transport-tunnel** CLI command can be used to select the specific transport LSP method. The **mpls** option under **transport-tunnel** enables the option to select either an RSVP-TE LSP or LDP LSP. If the **mpls** option is selected, an RSVP-TE LSP is considered the higher-priority LSP and its availability is checked first. If an RSVP-TE LSP is not available, then an LDP LSP is selected.

### 6.3.6 Next-hop resolution of BGP labeled routes to tunnels

The 7705 SAR always attempts to resolve the next hop of a label-IPv4 or label-IPv6 route. When **enable-rr-vpn-forwarding** and **next-hop-self** are enabled on a router configured as a route reflector, the 7705 SAR also attempts to resolve the next hop of VPN-IPv4 or VPN-IPv6 routes. The resolution is attempted as follows. If the first condition does not apply, the 7705 SAR moves to the next, and so on:

- if the BGP next hop is part of a local subnet, the next hop is resolved by the interface route
- if there is a static-route entry with a blackhole next hop that matches the BGP next hop, this static route resolves the route
- if there is a tunnel in the tunnel-table with a destination that matches the BGP next-hop address and the tunnel type is allowed by the **label-route-transport-tunnel family** command and is the tunnel with the numerically lowest TTM preference to the destination, this tunnel resolves the route
- if none of the above conditions apply, the next hop is unresolved and invalid

Use the following CLI syntax to configure next-hop resolution of BGP labeled routes.

#### CLI syntax:

```
config>router>bgp>next-hop-res
label-route-transport-tunnel
family {vpn |label-ipv4 |label-ipv6}
resolution {any | filter | disabled}
resolution-filter
[no] ldp
[no] rsvp
[no] sr-isis
[no] sr-ospf
[no] sr-te
```

The **label-route-transport-tunnel** context provides separate control for the different types of BGP label routes: label-IPv4, label-IPv6, and VPN routes (which includes both VPN-IPv4 and VPN-IPv6 routes). By default, all labeled routes resolve to LDP (even if the preceding CLI commands are not configured in the system).

If the **resolution** option is set to **disabled**, the default binding to LDP tunnels resumes. If **resolution** is set to **any**, the supported tunnel type selection is based on TTM preference. The order of preference of TTM tunnels is: RSVP, SR-TE, LDP, SR-OSPF, and SR-ISIS.

The **rsvp** option instructs BGP to search for the best metric RSVP-TE LSP to the address of the BGP next hop. The address can correspond to the system interface or to another loopback used by the BGP instance on the remote node. The LSP metric is provided by MPLS in the tunnel table. If there are multiple RSVP-TE LSPs with the same lowest metric, BGP selects the LSP with the lowest tunnel ID.

The **ldp** option instructs BGP to search for an LDP LSP with a FEC prefix corresponding to the address of the BGP next hop.

When the **sr-isis** or **sr-ospf** option is enabled, an SR tunnel to the BGP next hop is selected in the TTM from the lowest preference IS-IS instance or from OSPF. If multiple instances have the same lowest preference, the lowest-numbered IS-IS instance is selected.

The **sr-te** option instructs BGP to search for the best metric SR-TE LSP to the address of the BGP next hop. The LSP metric is provided by MPLS in the tunnel table. If there are multiple SR-TE LSPs with the same lowest metric, BGP selects the LSP with the lowest tunnel ID.

If one or more explicit tunnel types are specified using the **resolution-filter** option, only these tunnel types are selected again following the TTM preference. The **resolution** command must be set to **filter** to activate the list of tunnel types configured with the **resolution-filter** command.

### 6.3.7 BGP next-hop resolution and peer tracking

The 7705 SAR can attach a route policy to the BGP next-hop resolution process and can allow a route policy to be associated with the optional BGP peer-tracking function. These two features are also supported for VPRN BGP service.

BGP next-hop resolution determines the best matching route (or tunnel) for the BGP next-hop address and uses information about this resolving route when running the best-path selection algorithm and programming the forwarding table. Attaching a policy to BGP next-hop resolution provides additional control over which IP routes in the routing table can become resolving routes. Similar flexibility and control is available for BGP peer tracking, which is an optional feature that allows a session with a BGP neighbor to be taken down if there is no IP route to the neighbor address or if the best matching IP route is rejected by the policy.

Use the following CLI syntax to configure next-hop resolution and peer-tracking policies:

#### CLI syntax:

```
config>router>bgp
  next-hop-resolution
    policy policy-name
    no policy
  peer-tracking-policy policy-name
  no peer-tracking-policy
```

For details, see the "Route Policies for BGP Next-Hop Resolution and Peer Tracking" section in the 7705 SAR Router Configuration Guide.

### 6.3.8 BGP route installation in the route table

Each BGP RIB that is holding routes (unlabeled IPv4, labeled unicast IPv4, unlabeled IPv6) submits its best path for each prefix to the common IP route table. Prefixes to labeled unicast IPv4 routes may be blocked if **selective-label-ipv4-install** command is enabled. See [BGP-LU selective download](#) for more information. It is up to the route table to choose the best path for forwarding to each IP prefix destination. The route table chooses the route by using the BGP decision process. The default preference for BGP

routes submitted by the label-IPv4 or label-IPv6 RIBs (which appear in the route table and FIB as having a BGP-LABEL protocol type) can be modified using the **label-preference** command. The default preference for BGP routes submitted by the unlabeled IPv4 and IPv6 RIBs can be modified by using the **preference** command.

If a BGP RIB has multiple BGP paths (LOC-RIB routes) for the same IPv4 or IPv6 prefix that qualify as the best path up to a certain point in the comparison process, a certain number of these paths can be submitted to the common IP route table. This functionality is called BGP multipath and it must be explicitly enabled using the **multipath** command. The **multipath** command specifies the maximum number of BGP paths, including the overall best path, that each BGP RIB can submit to the route table for any particular IPv4 or IPv6 prefix. If ECMP, with a limit of  $n$ , is enabled in the base router instance, then up to  $n$  paths are selected for installation in the IP FIB. In the datapath, traffic matching the IP route is load-shared across the ECMP next hops based on a per-packet hash calculation.

By default, the hashing is not sticky, meaning that when one or more of the equal-cost BGP next hops fail, all traffic flows matching the route are potentially moved to new BGP next hops.

In the route table, a BGP path to an IPv4 or IPv6 prefix is a candidate for installation as an ECMP next hop (subject to the path limits of the **multipath** and **ecmp** commands) only if it meets all of the following criteria:

- it is the overall best BGP path or it is tied with the overall best path up to and including the last step of the decision process summarized in [BGP decision process](#)
- compared with other paths with the same BGP NEXT\_HOP, it is the best path, based on evaluation of all steps of the BGP decision process
- it is the same type of route as the best path and all other paths installed with the **multipath** command, that is, it came from the same BGP RIB (labeled unicast or unlabeled)

The 7705 SAR also supports a feature called IBGP multipath. In some topologies, a BGP next hop is resolved by an IP route (for example a static, OSPF, or IS-IS route) that has multiple ECMP next hops. If **ibgp-multipath** is not configured, only one of these ECMP next hops is programmed as a next hop of the BGP route in the IOM. If **ibgp-multipath** is configured, the IOM attempts to use all of the ECMP next hops of the resolving route for forwarding.

Although the name of the **ibgp-multipath** command implies that it is specific to IBGP-learned routes, it applies to routes learned from any multi-hop BGP session, including routes learned from multi-hop EBGP peers.



**Note:** BGP multipath and IBGP multipath are not mutually exclusive and work together. BGP multipath enables ECMP load-sharing across different BGP next hops (corresponding to different LOC-RIB routes) and IBGP multipath enables ECMP load-sharing across different IP next hops of IP routes that resolve the BGP next hops.

IBGP multipath does not control load-sharing of traffic toward a BGP next hop that is resolved by a tunnel, such as when dealing with labeled routes (VPN-IP, label-IPv4, or label-IPv6). When a BGP next hop is resolved by a tunnel that supports ECMP, the load-sharing of traffic across the ECMP next hops of the tunnel is automatic.

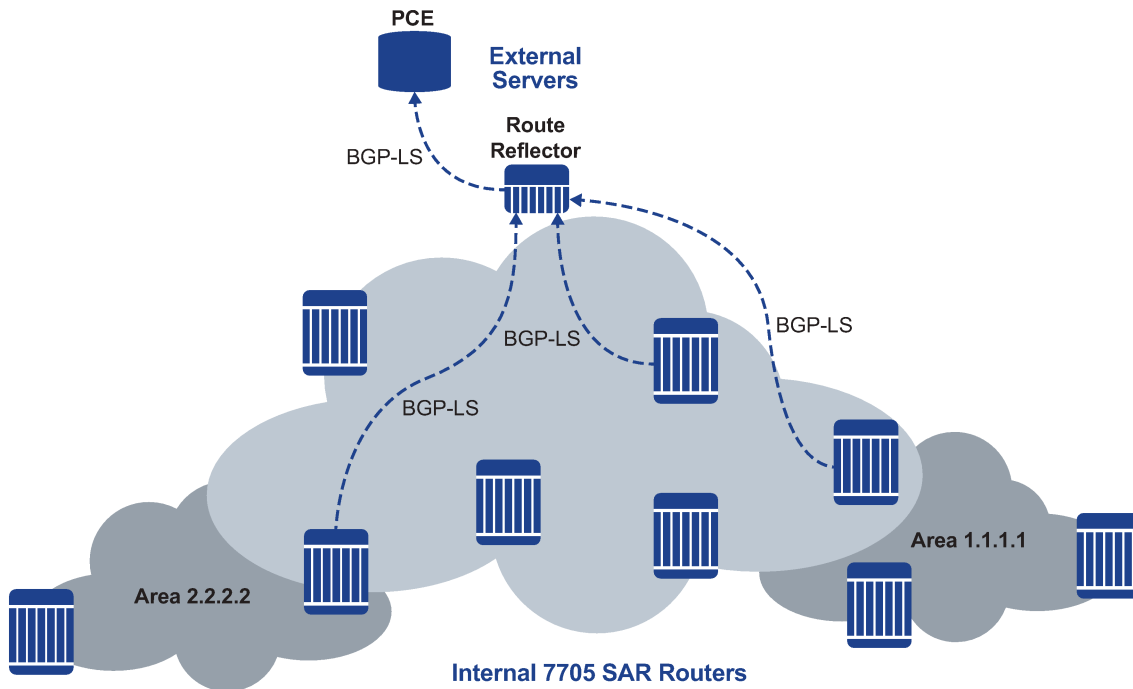
### 6.3.9 BGP link state

BGP link state (BGP-LS) is a BGP address family that distributes multi-area or multi-level network IGP topology information to an external server, such as a Path Computation Element (PCE) server. The external traffic engineering database can use this information when calculating optimal paths. Through the

use of one or two BGP-LS speakers per area (for OSPF) or level (for IS-IS), the external PCE server can receive full topology information for the entire network. By using BGP-LS, IGP link-state information can be extracted from different portions of the network (areas or levels) without the need for direct adjacencies. This allows the external server to develop a complete end-to-end view of the network topology and traffic engineering information.

The following figure shows an example of a BGP-LS network.

Figure 44: Example of a BGP-LS network



28910

### 6.3.9.1 Supported BGP-LS components

The following BGP-LS components are supported.

Protocol-ID:

- IS-IS level 1
- IS-IS level 2
- OSPFv2

NLRI types:

- Node
- Link
- IPv4 Prefix

Node Descriptor TLVs:

- 512 – Autonomous System

- 513 – BGP-LS Identifier
- 514 – OSPF Area-ID
- 515 – IGP Router-ID

Node Attribute TLVs:

- 1024 – Node Flag Bits (O and B bits supported)
- 1028 – IPv4 Router-ID of Local Node (IS-IS only)
- Segment Routing:
  - 1034 – SR Capabilities (IS-IS only)
  - 1035 – SR Algorithm (IS-IS only)

Link Descriptor TLVs:

- 258 – Link Local/Remote Identifiers
- 259 – IPv4 interface address
- 260 – IPv4 neighbor address

Link Attribute TLVs:

- 1028 – IPv4 Router-ID of Local Node (IS-IS only)
- 1088 – Administrative group (color)
- 1089 – Maximum link bandwidth
- 1090 – Maximum reservable link bandwidth
- 1091 – Unreserved bandwidth
- 1092 – TE Default Metric
- 1095 – IGP Metric
- 1096 – Shared Risk Link Group
- Segment Routing:
  - 1099 – Adjacency Segment Identifier
  - 1100 – LAN Adjacency Segment Identifier

Prefix Descriptor TLVs:

- 264 – OSPF Route Type (Intra-Area and Inter-Area only)
- 265 – IP Reachability Information

Prefix Attribute TLVs:

- 1152 – IGP Flags (D flag only)
- 1155 – Prefix Metric
- Segment Routing:
  - 1158 – Prefix SID
  - 1159 – Range (prefix-SID and sub-TLV only)
  - 1170 – Prefix Attribute Flags (OSPF only)

## 6.4 Command interactions and dependencies

This section highlights the BGP command interactions and dependencies that are important for configuration or operational maintenance of 7705 SAR routers. Topics covered in this section are:

- [Changing the autonomous system number](#)
- [Changing the local AS number](#)
- [Changing the router ID at the configuration level](#)
- [Hold time and keepalive timer dependencies](#)
- [Import and export route policies](#)
- [AS override](#)
- [TCP MD5 authentication](#)
- [TTL security](#)
- [Advertise-inactive](#)
- [Advertise-inactive, add-paths, and export policy interaction](#)

This information can be found in the [BGP command reference](#), which provides detailed descriptions of the configuration commands.

### 6.4.1 Changing the autonomous system number

If the AS number is changed on a router with an active BGP instance, the new AS number will not be used until the BGP instance is restarted either by administratively disabling or enabling the BGP instance or by rebooting the system with the new configuration.



**Note:** The 7705 SAR supports 4-byte AS numbers, as defined in RFC 4893, *BGP Support for Four-octet AS Number Space*. This allows up to 4 294 967 295 unique AS numbers.

### 6.4.2 Changing the local AS number

Changing the local AS of an active BGP instance:

- at the global level – causes the BGP instance to restart with the new local AS number
- at the group level – causes BGP to re-establish the peer relationships with all peers in the group with the new local AS number
- at the neighbor level – causes BGP to re-establish the peer relationship with the new local AS number

### 6.4.3 Changing the router ID at the configuration level

If you configure a new router ID in the **config>router-id** context, protocols are not automatically restarted with the new router ID. The next time a protocol is initialized or reinitialized, the new router ID is used. An interim period of time can occur when different protocols use different router IDs.

### 6.4.4 Hold time and keepalive timer dependencies

The BGP hold time specifies the maximum time BGP will wait between successive messages (either Keepalive or Update) from its peer, before closing the connection. This configuration parameter can be set at three levels. The most specific value is used:

- global level – applies to all peers
- group level – applies to all peers in the group
- neighbor level – only applies to the specified peer

Although the keepalive time can be user-specified, the configured keepalive timer is overridden by the value of hold time under the following circumstances:

- If the hold time specified is less than the configured keepalive time, then the operational keepalive time is set to one third of the specified hold time; the configured keepalive time is unchanged.
- If the hold time is set to zero, the operational value of the keepalive time is set to zero; the configured keepalive time is unchanged. This means that the connection with the peer will be up permanently and no keepalive packets are sent to the peer.

If the hold time or keepalive values are changed, the changed timer values take effect when the new peering relationship is established. Changing the values causes the peerings to restart. The changed timer values are used when renegotiating the peer relationship.

### 6.4.5 Import and export route policies

Import and export route policy statements are specified for BGP at the global, group, and neighbor level. Up to five unique policy statement names can be specified in the command line per level. The most specific command is applied to the peer. Defining the policy statement name is not required before being applied. Policy statements are evaluated in the order in which they are specified within the command context until the first matching policy statement is found.

The import and export policies configured at different levels are not cumulative. The most specific value is used. An import or export policy command specified at the neighbor level takes precedence over the same command specified at the group or global level. An import or export policy command specified at the group level takes precedence over the same command specified at the global level.

### 6.4.6 AS override

BGP-4 explicit AS override simplifies the use of the same AS number (ASN) across multiple RFC 2547 VPRN sites.

The explicit AS override feature can be used in VPRN scenarios where a customer is running BGP as the PE-CE protocol and some or all of the CE locations are in the same autonomous system (AS). Without this feature, two sites in the same AS would not be able to reach each other directly because there is an apparent loop in the AS path.

With AS override enabled on an EBGP session on a PE node, the service provider network can rewrite the AS path—overriding the customer ASN with its own ASN—as routes are advertised to other sites within the same VPRN.

## 6.4.7 TCP MD5 authentication

The operation of a network can be compromised if an unauthorized system is able to form or hijack a BGP session and inject control packets by falsely representing itself as a valid neighbor. This risk can be mitigated by enabling TCP MD5 authentication on one or more of the sessions. When TCP MD5 authentication is enabled on a session, every TCP segment exchanged with the peer includes a TCP option (19) containing a 16-byte MD5 digest of the segment (more specifically the TCP/IP pseudo-header, TCP header, and TCP data). The MD5 digest is generated and validated using an authentication key that must be known to both sides. If the received digest value is different from the locally computed one, the TCP segment is dropped, thereby protecting the router from a spoofed TCP segment.

The TCP Enhanced Authentication Option, as specified in *draft-bonica-tcpauth-05, Authentication for TCP-based Routing and Management Protocols*, is a TCP extension that enhances security for BGP, LDP, and other TCP-based protocols. It extends the MD5 authentication option to include the ability to change keys in a BGP or LDP session seamlessly without tearing down the session, and allows for stronger authentication algorithms to be used. It is intended for applications where secure administrative access to both endpoints of the TCP connection is normally available.

TCP peers can use this extension to authenticate messages passed between one another. This strategy improves upon the practice described in RFC 2385, *Protection of BGP Sessions via the TCP MD5 Signature Option*. Using this new strategy, TCP peers can update authentication keys during the lifetime of a TCP connection. TCP peers can also use stronger authentication algorithms to authenticate routing messages.

TCP enhanced authentication uses keychains that are associated with every protected TCP connection.

Keychains are configured in the **config>system>security>keychain** context. For more information about configuring keychains, see the 7705 SAR System Management Guide, "TCP Enhanced Authentication and Keychain Authentication".

## 6.4.8 TTL security

TTL security provides protection for EBGP peering sessions against CPU utilization-based attacks such as denial of service (DoS) attacks. This feature is supported for directly connected peering sessions and for multihop EBGP peering sessions. The BGP session can be over router interfaces, over spoke-SDP terminated VPRN interfaces, SAP interfaces, and loopback interfaces, and over IPsec interface tunnels.

TTL security is most important for EBGP PE-CE sessions because CE devices can be multiple hops away, which adds a higher level of risk. TTL security provides a mechanism to better ensure the validity of BGP sessions from the CE device.

TTL security is configured at the group or neighbor level. The **tll-security** command sets the minimum TTL that will be accepted in a BGP peering session and checks the TTL of the packets received. For multihop peering sessions, the **multihop** command sets the TTL in the IP header of egress BGP packets sent to a terminating peer that is several hops away.

When TTL security is configured, the network processor must inspect BGP packets. The value in the TTL field of received IP packets is compared with the TTL security value that is configured locally for each EBGP peering session. If the value in the TTL field of the incoming IP packet is greater than or equal to the configured minimum TTL value, the IP packet is accepted and processed normally. If the TTL value is less than the configured value, the packet is discarded.



## 6.4.9 Advertise-inactive

BGP does not allow a route to be advertised unless it is the best path in the RIB and an export policy allows the advertisement.

In some cases, it may be useful to advertise the best BGP path to peers despite the fact that it is inactive; for example, if there are one or more lower-preference non-BGP routes to the same destination and one of these other routes is the active route. This flexibility is supported using the **advertise-inactive** and **add-path** commands.

As a global BGP configuration option, the **advertise-inactive** command applies to all IPv4, IPv6, label-IPv4, and label-IPv6 routes and all sessions that advertise these routes. If the command is configured and the best BGP path is inactive, it is automatically advertised to every peer unless rejected by a BGP export policy.

## 6.4.10 Advertise-inactive, add-paths, and export policy interaction

This section describes the interaction between the BGP **advertise-inactive**, **add-paths**, and **export** policy commands. The 7705 SAR allows the policy-based export of an active and installed route to a peer when the local router has BGP **advertise-inactive** enabled in its configuration.

The following behavior for **advertise-inactive** occurs when an active, non-BGP route (route A) exists in the routing table and is accepted by the configured BGP export policy:

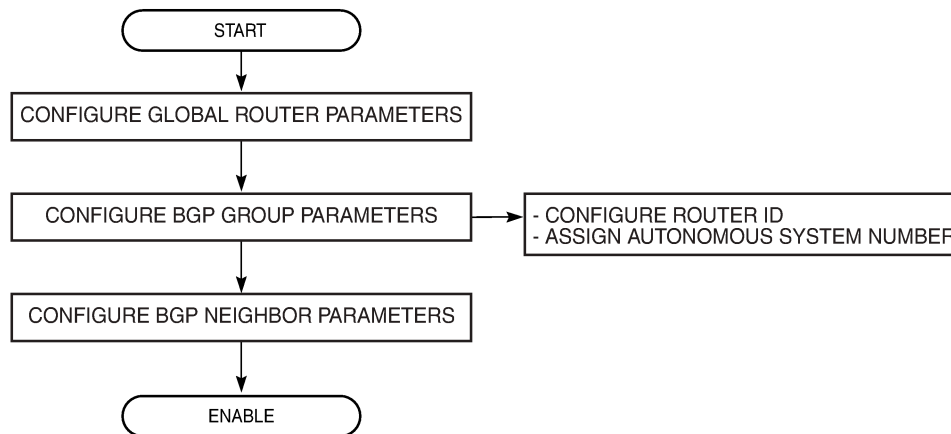
- If the **add-paths** *send-limit* is set to  $n$  paths, then BGP advertises  $n$  paths that are accepted by the export policy and have diverse next hops, whether **advertise-inactive** is enabled or disabled.  
For example, if  $n=3$ , then routes A, B1, and B2 are advertised (route A is counted as one of the paths), as long as route A is accepted by the export policy. Otherwise, routes B1, B2 and B3 are advertised.
- If **add-paths** is disabled and **advertise-inactive** is enabled, then BGP advertises one active non-BGP route if the route is accepted by the export policy. Otherwise, BGP advertises the best BGP route that is accepted by the policy.

For example, BGP advertises either route A or route B1, depending on the export policy.

## 6.5 BGP configuration process overview

The following figure displays the process to provision basic BGP parameters.

Figure 45: BGP configuration and implementation flow



21827

## 6.6 Configuration notes

This section describes BGP configuration guidelines and restrictions.

### 6.6.1 General

- Before BGP can be configured, the router ID (a valid host address, not the MAC address default) and autonomous system global parameters must be configured.
- BGP instances must be explicitly created on each BGP peer. There are no default BGP instances on a 7705 SAR.

### 6.6.2 BGP defaults

The following list summarizes the BGP configuration defaults:

- By default, the 7705 SAR is not assigned to an AS.
- A BGP instance is created in the administratively enabled state.
- A BGP group is created in the administratively enabled state.
- A BGP neighbor is created in the administratively enabled state.
- No BGP router ID is specified. If no BGP router ID is specified, BGP uses the router system interface address.
- The 7705 SAR BGP timer defaults are the values recommended in IETF drafts and RFCs (see [BGP MIB notes](#)).
- If no import route policy statements are specified, then all BGP routes are accepted.
- If no export route policy statements specified, then all BGP routes are advertised and non-BGP routes are not advertised.

### 6.6.3 BGP MIB notes

The 7705 SAR implementation of the RFC 1657 MIB variables listed in the following table differs from the IETF MIB specification.

Table 85: 7705 SAR and IETF MIB variations

MIB variable	Description	RFC 1657 allowed values	7705 SAR allowed values
bgpPeerMinASOriginationInterval	Time interval in seconds for the MinASOriginationInterval timer. The suggested value for this timer is 15 s.	1 to 65535	2 to 255
bgpPeerMinRouteAdvertisementInterval	Time interval in seconds for the MinRouteAdvertisementInterval timer. The suggested value for this timer is 30 s.	1 to 65535	2 to 255

If SNMP is used to set a value of X to the MIB variable in the following table, there are three possible results:

Table 86: MIB variable with SNMP

Condition	Result
X is within IETF MIB values and X is within 7705 SAR values	SNMP set operation does not return an error MIB variable set to X
X is within IETF MIB values and X is outside 7705 SAR values	SNMP set operation does not return an error MIB variable set to "nearest" 7705 SAR supported value (for example, 7705 SAR range is 2 to 255 and X = 65535, MIB variable will be set to 255) Log message generated
X is outside IETF MIB values and X is outside 7705 SAR values	SNMP set operation returns an error

When the value set using SNMP is within the IETF allowed values and outside the 7705 SAR values as specified in [Table 85: 7705 SAR and IETF MIB variations](#) and [Table 86: MIB variable with SNMP](#), a log message is generated. The log messages that display are similar to the following log messages.

Log Message for setting bgpPeerMinASOriginationInterval to 65535

576 2006/11/12 19:45:48 [Snmpd] BGP-4-bgpVariableRangeViolation: Trying to set bgpPeerMinASOrigInt to 65535 - valid range is [2-255] - setting to 255:

Log Message for setting bgpPeerMinASOriginationInterval to 1

594 2006/11/12 19:48:05 [Snmpd] BGP-4-bgpVariableRangeViolation: Trying to set bgpPeerMinASOrigInt to 1 - valid range is [2-255] - setting to 2:

Log Message for setting bgpPeerMinRouteAdvertisementInterval to 256

535 2006/11/12 19:40:53 [Snmpd] BGP-4-bgpVariableRangeViolation: Trying to set bgpPeerMinRouteAdvInt to 256 - valid range is [2-255] - setting to 255:

Log Message for setting bgpPeerMinRouteAdvertisementInterval to 1

566 2006/11/12 19:44:41 [Snmpd] BGP-4-bgpVariableRangeViolation: Trying to set bgpPeerMinRouteAdvInt to 1 - valid range is [2-255] - setting to 2

## 6.7 Configuring BGP with CLI

This section provides information to configure BGP using the command line interface.

Topics in this section include:

- [BGP configuration overview](#)
- [Basic BGP configuration](#)
- [Common configuration tasks](#)
- [BGP components](#)
- [BGP configuration management tasks](#)

## 6.8 BGP configuration overview

### 6.8.1 Preconfiguration requirements

Before BGP can be implemented, the following entities must be configured:

- the autonomous system (AS) number for the router

An AS number is a globally unique value that associates a router with a specific autonomous system. This number is used to exchange exterior routing information with neighboring ASs and as an identifier of the AS itself. Each router participating in BGP must have an AS number specified.

In order to implement BGP, the AS number must be specified in the **config>router** context.

- the router ID

The router ID is the IP address of the local router. The router ID identifies a packet's origin. The router ID must be a valid host address.

## 6.8.2 BGP hierarchy

BGP is configured in the **config>router>bgp** context. Three hierarchical levels are included in BGP configurations:

- global level
- group level
- neighbor level

Commands and parameters configured at the global level are inherited by the group and neighbor levels, although parameters configured at the group and neighbor levels take precedence over global configurations.

## 6.8.3 Internal and external BGP configurations

A BGP domain is composed of ASs that share network reachability information. Network reachability information is shared throughout the BGP domain by BGP speakers. BGP speakers can belong to the same or different AS. BGP supports two types of routing information exchanges:

- Internal BGP (IBGP) is used within an AS. An IBGP speaker peers to the same AS and typically does not share a subnet. Neighbors (peers) do not have to be directly connected to each other. Since IBGP neighbors are not required to be directly connected, IBGP uses the IGP path (the IP next hop learned from the IGP) to reach an IBGP neighbor for its peering connection.

The 7705 SAR supports IBGP, for MP-BGP purposes, only within the router context.

- External BGP (EBGP) is used between ASs. EBGP speakers peer to different ASs and typically share a subnet. In an external group, the next hop is dependent upon the interface shared between the external peer and the local one. The **multihop** command must be specified if an EBGP peer is more than one hop away from the local router. The next hop to the peer must be configured so that the two EBGP speakers can establish a BGP session.

The 7705 SAR supports EBGP within the router context and VPRN context. For information about configuring EBGP within the VPRN context, see the 7705 SAR Services Guide, "VPRN Services".

## 6.8.4 BGP route reflectors

In a standard BGP configuration, all BGP speakers within an AS must have a full BGP mesh to ensure that all externally learned routes are redistributed through the entire AS. IBGP speakers do not readvertise routes learned from one IBGP peer to another IBGP peer. If a network grows, scaling issues could emerge because of the full mesh configuration requirement. Route reflection circumvents the full mesh requirement but still maintains the full distribution of external routing information within an AS.

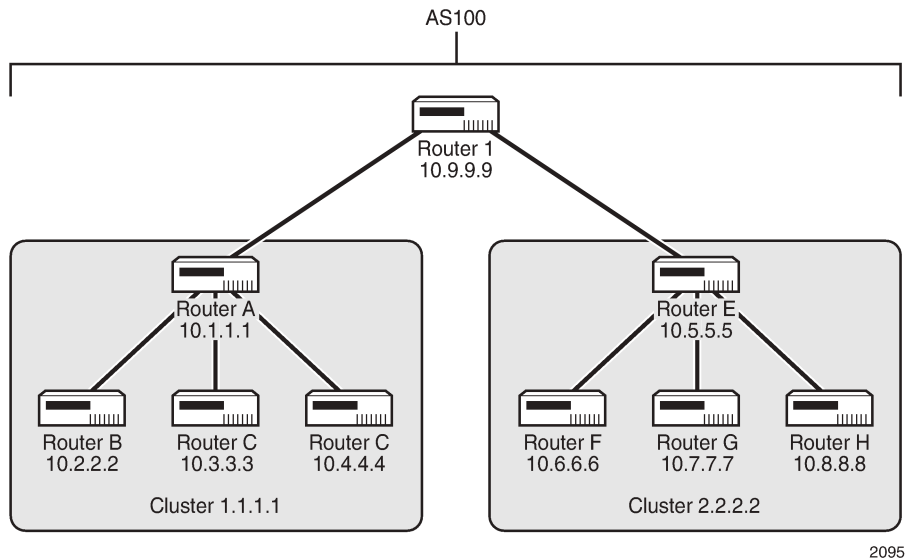
Autonomous systems using route reflection arrange BGP routers into groups called clusters. Each cluster contains at least one route reflector that is responsible for redistributing route updates to all clients. Route reflector clients do not need to maintain a full peering mesh between each other. They only require a peering to the route reflectors in their cluster. The route reflectors must maintain a full peering mesh between all non-clients within the AS.

Each route reflector must be assigned a cluster ID and specify which neighbors are clients and which are non-clients to determine which neighbors should receive reflected routes and which should be treated as

a standard IBGP peer. Additional configuration is not required for the route reflector except for the typical BGP neighbor parameters.

The following figure illustrates an autonomous system with clusters.

*Figure 46: Route reflection network diagram example*



The following configuration example shows the minimum BGP configuration for routers in Cluster 1.1.1.1, shown in [Figure 46: Route reflection network diagram example](#).

```

ALU-A
  config router bgp
    group cluster1
      peer-as 100
      cluster 1.1.1.1
      neighbor 10.2.2.2
      exit
      neighbor 10.3.3.3
      exit
      neighbor 10.4.4.4
      exit
    exit
    group RRs
      peer-as 100
      neighbor 10.5.5.5
      exit
      neighbor 10.9.9.9
      exit
    exit
  exit
ALU-B
  config router bgp
    group cluster1
      peer-as 100
      neighbor 10.1.1.1
      exit
    exit
  exit
ALU-C

```

```

config router bgp
  group cluster1
    peer-as 100
    neighbor 10.1.1.1
  exit
exit
exit
ALU-D
config router bgp
  group cluster1
    peer-as 100
    neighbor 10.1.1.1
  exit
exit
exit

```

## 6.9 Basic BGP configuration

This section provides information to configure BGP and configuration examples of common configuration tasks. The minimum BGP parameters that must be configured are:

- an autonomous system number for the router
- a router ID
- a BGP peer group
- a BGP neighbor with which to peer
- a BGP peer-AS that is associated with the above peer



**Note:** If a new or different router ID value is entered in the BGP context, the new value takes precedence and overwrites the router-level router ID.

The BGP configuration commands have three primary configuration levels:

- global configuration (**config>router>bgp**)
- BGP group configuration (**config>router>bgp>group**)
- BGP neighbor configuration (**config>router>bgp>group>neighbor**)

Within the three levels, many of the configuration commands are repeated. For the repeated commands, the command that is most specific to the neighboring router is in effect; that is, neighbor settings have precedence over group settings, which have precedence over BGP global settings.

The following is an example of a configuration that includes the parameters in the list above. The other parameters shown below are optional:

```

info
#-----
echo "IP Configuration"
#-----
...
  autonomous-system 200
  router-id 10.10.10.103
#-----
...
#-----
echo "BGP Configuration"
#-----

```

```
bgp
 graceful-restart
 exit
 cluster 0.0.0.100
 damping
 export "direct2bgp"
 router-id 10.0.0.12
 group "Group1"
   connect-retry 20
   damping
   hold-time 90
   keepalive 30
   local-preference 100
   multihop 3
   remove-private
   peer-as 200
   ttl-security 10
   neighbor 10.0.0.8
     connect-retry 20
     damping
     hold-time 90
     keepalive 30
     local-address 10.0.0.12
     multihop 3
     passive
     preference 99
     peer-as 200
     ttl-security 10
   exit
 exit
 group "Group2"
   connect-retry 20
   damping
   hold-time 90
   keepalive 30
   local-preference 100
   remove-private
   peer-as 200
   neighbor 10.0.3.10
     description "To_Router C - IBGP Peer"
     connect-retry 20
     damping
     hold-time 90
     keepalive 30
     peer-as 200
   exit
 exit
 group "Group3"
   connect-retry 20
   damping
   hold-time 30
   keepalive 30
   local-preference 100
   peer-as 200
   neighbor 10.0.0.15
     description "To_Router E - IBGP Peer"
     connect-retry 20
     damping
     hold-time 90
     keepalive 30
     local-address 10.0.0.12
     peer-as 200
   exit
 exit
```



## 6.10 Common configuration tasks

This section provides a brief overview of the tasks that must be performed to configure BGP and provides the CLI commands. In order to enable BGP, one AS must be configured and at least one group must be configured that includes neighbor (system or IP address) and peering information (AS number).

BGP is configured hierarchically; the global level applies to all peers, the group level applies to all peers in a group, and the neighbor level only applies to a specified peer. By default, group members inherit the group's configuration parameters, although a parameter can be modified on a per-member basis without affecting the group-level parameters.

Many of the hierarchical BGP commands can be used at different levels. The most specific value is used. That is, a BGP group-specific command takes precedence over a global BGP command. A neighbor-specific command takes precedence over a global BGP or group-specific command.

All BGP instances must be explicitly created on each 7705 SAR. When created, BGP is administratively enabled.

Configuration planning is essential to organize ASs and the 7705 SARs within the ASs, and to determine the internal and external BGP peering. To configure a basic autonomous system, perform the following tasks:

1. Prepare a plan detailing the autonomous systems, the 7705 SAR belonging to each group, group names, and peering connections.
2. Associate each 7705 SAR with an autonomous system number.
3. Configure each 7705 SAR with a router ID.
4. Associate each 7705 SAR with a peer group name.
5. Specify the local IP address that will be used by the group or neighbor when communicating with BGP peers.
6. Specify neighbors.
7. Specify the autonomous system number associated with each neighbor.

### 6.10.1 Creating an autonomous system

Before BGP can be configured, the autonomous system must be configured. In BGP, routing reachability information is exchanged between autonomous systems (ASs). An AS is a group of networks that share routing information. The **autonomous-system** command associates an autonomous system number with the 7705 SAR being configured. A 7705 SAR can only belong to one AS. The **autonomous-system** command is configured in the **config>router** context.



**Note:** The 7705 SAR supports 4-byte AS numbers, as defined in RFC 4893, *BGP Support for Four-octet AS Number Space*. This allows up to 4 294 967 295 unique AS numbers.

Use the following CLI syntax to associate a 7705 SAR with an autonomous system:

**CLI syntax:**

```
config>router# autonomous-system as-number
```

The following example displays autonomous system configuration command usage:

**Example:**

```
config>router# autonomous-system 100
```

The following example displays the autonomous system configuration:

```
ALU-B>config>router# info
#-----
# IP Configuration
#-----
    interface "system"
        address 10.10.10.104/8
    exit
    interface "to-103"
        address 10.0.0.104/8
        port 1/1/1
    exit
    autonomous-system 100
#-----
ALU-B>config>router#
```

## 6.10.2 Configuring a router ID

In BGP, routing information is exchanged between autonomous systems. The BGP router ID, expressed as an IP address, uniquely identifies the router. It can be set to be the same as the loopback address.

If a new or different router ID value is entered in the BGP context, the new router ID value is used instead of the router ID configured on the router level, system interface level, or inherited from the MAC address. The router-level router ID value remains intact.

A router ID can be derived by:

- defining the value in the **config>router** context, using the **router-id** command
- defining the system interface in the **config>router>interface ip-int-name** context
- inheriting the last four bytes of the MAC address
- defining the value within the BGP protocol level. The router ID can be defined in the **config>router>bgp** context, using the **router-id** command, and is only used within BGP.

When configuring a new router ID, protocols are not automatically restarted with the new router ID. The next time a protocol is initialized or reinitialized, the new router ID is used. An interim period of time can occur when different protocols use different router IDs. To force the new router ID, issue the **shutdown** and **no shutdown** commands for each protocol that uses the router ID or restart the entire router.

Use the following CLI syntax to configure the router ID:

**CLI syntax:**

```
config>router# router-id ip-address
```

The following example displays router ID configuration command usage:

**Example:**

```
config>router# router-id 10.10.10.104
```

The following example displays the router ID configuration:

```
ALU-B>config>router# info
-----
# IP Configuration
#-----
  interface "system"
    address 10.10.10.104/8
  exit
  interface "to-103"
    address 10.0.0.104/8
    port 1/1/1
  exit
  autonomous-system 100
  router-id 10.10.10.104
#-----
ALU-B>config>router#
```

## 6.11 BGP components

This section describes how to configure the following BGP attributes:

- [Configuring BGP](#)
- [Configuring group attributes](#)
- [Configuring neighbor attributes](#)
- [Configuring BGP address families](#)
- [Configuring route reflection](#)
- [Configuring a BGP peer group with dynamic neighbors](#)

### 6.11.1 Configuring BGP

When the BGP protocol instance is created, the **no shutdown** command is not required since BGP is administratively enabled upon creation. Minimally, to enable BGP on a router, you must associate an autonomous system number for the router, have a preconfigured router ID or system interface, create a peer group, neighbor, and associate a peer AS number. There are no default groups or neighbors. Each group and neighbor must be explicitly configured.

All parameters configured for BGP are applied to the group and are inherited by each peer, but a group parameter can be overridden on a specific basis. BGP command hierarchy consists of three levels:

- the global level
- the group level
- the neighbor level

For example:

**CLI syntax:**

```
config>router# bgp      (global level)
                 group   (group level)
                 neighbor (neighbor level)
```



**Note:** Careful planning is essential to implement commands that can affect the behavior of global, group, and neighbor levels. Because the BGP commands are hierarchical, analyze the values that can disable features on a particular level.

The following example displays the basic BGP configuration:

```
ALU-B>config>router# info
#-----
# BGP Configuration
#-----
# BGP
#-----
      bgp
      exit
#-----
ALU-B>config>router#
```

## 6.11.2 Configuring group attributes

A group is a collection of related BGP peers. The group name should be a descriptive name for the group. Follow your group naming and ID naming conventions for consistency and to help when troubleshooting faults. All parameters configured for a peer group are applied to the group and are inherited by each peer (neighbor), but a group parameter can be overridden on a specific neighbor-level basis. To configure BGP dynamic peers, see [Configuring a BGP peer group with dynamic neighbors](#).

The following example displays group configuration command usage:

### Example:

```
config>router# bgp
config>router>bgp# group headquarters1
config>router>bgp>group# description "HQ execs"
config>router>bgp>group# multihop 3
config>router>bgp>group# med-out 100
config>router>bgp>group# ttl-security 10
config>router>bgp>group# local-address 10.0.0.104
config>router>bgp>group# disable-communities standard
config>router>bgp>group# exit
```

The following example displays the BGP group configuration:

```
ALU-B>config>router>bgp# info
-----
...
  group "headquarters1"
    description "HQ execs"
    multihop 3
    med-out 100
    local-address 10.0.0.104
    disable-communities standard
    ttl-security 10
    exit
  exit
...
-----
```

### 6.11.3 Configuring neighbor attributes

After you create a group name and assign options, add neighbors within the same autonomous system to create IBGP connections. All parameters configured for the peer group level are applied to each neighbor, but a group parameter can be overridden on a specific neighbor basis.

The following example displays neighbor configuration command usage:

**Example:**

```
config>router# bgp
config>router>bgp# group headquarters1
config>router>bgp>group# neighbor 10.0.0.5
config>router>bgp>group# multihop 3
config>router>bgp>group# peer-as 100
config>router>bgp>group# passive
config>router>bgp>group# ttl-security 10
config>router>bgp>group# exit
config>router>bgp>group# neighbor 10.10.10.6
config>router>bgp>group# multihop 255
config>router>bgp>group# med-out 100
config>router>bgp>group# peer-as 100
config>router>bgp>group# exit
config>router>bgp>group# neighbor 10.10.10.7
config>router>bgp>group>neighbor$ hold-time 90
config>router>bgp>group>neighbor$ keepalive 30
config>router>bgp>group>neighbor$ local-preference 170
config>router>bgp>group# multihop 255
config>router>bgp>group# med-out 100
config>router>bgp>group>neighbor$ peer-as 100
config>router>bgp>group>neighbor$ exit
config>router>bgp>group# neighbor 10.10.10.8
config>router>bgp>group>neighbor$ hold-time 90
config>router>bgp>group>neighbor$ keepalive 30
config>router>bgp>group>neighbor$ local-preference 100
config>router>bgp>group>neighbor$ min-route-advertisement 30
config>router>bgp>group>neighbor$ preference 170
config>router>bgp>group# multihop 255
config>router>bgp>group# med-out 100
config>router>bgp>group>neighbor$ peer-as 100
config>router>bgp>group>neighbor$ exit
config>router>bgp>group# exit
```

The following example displays neighbors configured in group "headquarters1".

```
ALU-B>config>router>bgp# info
-----
...
  group "headquarters1"
    description "HQ execs"
    local-address 10.0.0.104
    disable-communities standard extended
    neighbor 10.0.0.5
      multihop 3
      med-out 100
      peer-as 100
      passive
      ttl-security 10
    exit
    neighbor 10.0.0.106
      peer-as 100
    exit
```

```

neighbor 10.0.0.107
  hold-time 90
  keepalive 30
  local-preference 170
  multihop 255
  med-out 100
  peer-as 100
exit
neighbor 10.0.0.220
  hold-time 90
  keepalive 30
  min-as-origination 15
  local-preference 100
  preference 170
  multihop 255
  med-out 100
  peer-as 100
exit
exit
...
-----
ALU-B>config>router>bgp#

```

## 6.11.4 Configuring BGP address families

Routers advertise their BGP capabilities during session setup. The 7705 SAR supports several address families. One or more address families can be specified in a single command. To add an address family to the currently configured families, re-issue the command by including the current families in addition to any new family.

Use the following CLI syntax to configure BGP address family parameters:

### CLI syntax:

```

config>router router-name
  bgp
    family [ipv4] [vpn-ipv4] [ipv6] [vpn-ipv6] [mvpn-ipv4] [route-
target] [evpn] [label-ipv4] [label-ipv6] [bgp-ls]
    group name
      family [ipv4] [vnp-ipv4] [ipv6] [vpn-ipv6] [mnvp-ipv4] [route-
target] [evpn] [label-ipv4] [label-ipv6] [bgp-ls]
      neighbor ip-address
        family [ipv4] [vnp-ipv4] [ipv6] [vpn-ipv6] [mnvp-ipv4]
[route-target] [evpn] [label-ipv4] [label-ipv6] [bgp-ls]

```

In the display example below, the **mvpn-ipv4** address family is added to the BGP group to communicate auto-discovery routes and C-multicast signaling.

```

#-----
echo "BGP Configuration"
#-----
  bgp
    group "MVPN-BGP"
      family ipv4 vpn-ipv4 mvpn-ipv4
      peer-as 65000
      neighbor 10.10.10.125
      exit
      neighbor 10.10.10.127
      exit
    exit

```

```

no shutdown
exit
#-----

```

## 6.11.5 Configuring route reflection

Route reflection can be implemented in autonomous systems with a large internal BGP mesh to reduce the number of IBGP sessions required. One or more routers can be selected to act as focal points for internal BGP sessions. Several BGP speaking routers can peer with a route reflector. A route reflector forms peer connections to other route reflectors. A router assumes the role as a route reflector by configuring the **cluster** *cluster-id* command. No other command is required unless you want to disable reflection to specific peers.

If you configure the **cluster** command at the global level, then all subordinate groups and neighbors are members of the cluster. The route reflector cluster ID is expressed in dotted- decimal notation. The ID should be a significant topology-specific value. No other command is required unless you want to disable reflection to specific peers.

If a route reflector client is fully meshed, the **disable-client-reflect** command can be enabled to stop the route reflector from reflecting redundant route updates to a client.

The following example displays route reflection configuration command usage:

### Example:

```

config>router# bgp
config>router>bgp# cluster 0.0.0.100
config>router>bgp# group "Santa Clara"
config>router>bgp>group$ local-address 10.0.0.103
config>router>bgp>group# neighbor 10.0.0.91
config>router>bgp>group>neighbor$ peer-as 100
config>router>bgp>group>neighbor# exit
config>router>bgp>group# neighbor 10.0.0.92
config>router>bgp>group>neighbor$ peer-as 100
config>router>bgp>group>neighbor# exit
config>router>bgp>group# neighbor 10.0.0.93
config>router>bgp>group>neighbor$ disable-client-reflect
config>router>bgp>group>neighbor# peer-as 100
config>router>bgp>group>neighbor# exit

```

The following example displays a route reflection configuration:

```

ALU-B>config>router>bgp# info
-----
cluster 0.0.0.100
group "Santa Clara"
  local-address 10.0.0.103
  neighbor 10.0.0.91
    peer-as 100
  exit
  neighbor 10.0.0.92
    peer-as 100
  exit
  neighbor 10.0.0.93
    disable-client-reflect
    peer-as 100
  exit
exit
-----

```

```
ALU-B>config>router>bgp#
```

## 6.11.6 Configuring a BGP peer group with dynamic neighbors

The **dynamic-neighbor** command allows any router within the configured IP prefix range to establish BGP peering sessions with other routers in the prefix range without any manual intervention.

A BGP neighbor session is considered dynamic if its setup is triggered by an incoming TCP connection that does not match the IP address of any static (configured) neighbor. A dynamic BGP session is always associated with one BGP group, as is the case for statically configured peers.

For a base router BGP group to have dynamic sessions, one or more **prefix** command entries must be added under the **config>router>bgp>group>dynamic-neighbor** context. There is no limit on the number of prefix entries per group or overall.

The CLI blocks completely overlapping prefix entries in the same routing instance (that is, entries with the same address and same prefix length). Partially overlapping entries are allowed; for example, 10.0.0.0/8 and 10.10.0.0/16.

For a dynamic session to come up, its source IP address must match at least one prefix entry. The dynamic session is associated with the entry—and consequently, the group—having the longest prefix match for the IP address. When a dynamic session has been set up, changes to the neighbor may occur and are handled as follows:

- when a prefix already exists in a group and a new longer prefix entry is added to the same group, and if the session that already exists still matches on the newly prefix match, the session remains established and is not taken down
- when a prefix already exists in a group and a new longer prefix entry is added to a different group, and if the session that already exists now matches on the newly added prefix in the different group, the session is taken down in order to apply the new group parameters to the new session when it gets established
- when a new static neighbor is configured using the **neighbor** command in any group and the neighbor IP address matches the source IP address of the existing dynamic neighbor, the dynamic neighbor session is taken down and a new session is established using the configured parameters of the static neighbor

Static sessions always take precedence regardless of any longest-prefix match with a dynamic neighbor prefix entry.

The number of dynamic BGP peers can be limited at the BGP global and BGP group levels using the **dynamic-neighbor-limit** command, which limits the number of dynamic sessions allowed by the router and the group, respectively. If an incoming connection for a new dynamic session exceeds the BGP global or BGP group limit, the connection attempt is rejected and a notification message is issued.

The following example displays the **dynamic-neighbor** command usage:

### Example:

```
config>router# bgp
config>router>bgp# group "dynamic"
config>router>bgp>group# peer-as 100
config>router>bgp>group# dynamic-neighbor
config>router>bgp>group>dynamic-neighbor$ prefix 10.100.0.0/16
config>router>bgp>group>dynamic-neighbor# exit
config>router>bgp>group# dynamic-neighbor-limit 75
config>router>bgp>group# exit
```



The following example displays a dynamic neighbor configuration:

```
ALU-B>config>router>bgp# info
-----
...snip...

  group "dynamic"
    peer-as 100
    dynamic-neighbor
      prefix 10.100.0.0/16
    exit
    dynamic-neighbor-limit 75
  exit

...snip...
-----
ALU-B>config>router>bgp#
```

## 6.12 BGP configuration management tasks

This section discusses the following BGP configuration management tasks:

- [Modifying an AS number](#)
- [Modifying the BGP router ID](#)
- [Modifying the router-level router ID](#)
- [Deleting a neighbor](#)
- [Deleting groups](#)
- [Editing BGP parameters](#)

### 6.12.1 Modifying an AS number

You can modify an AS number on a 7705 SAR but the new AS number will not be used until the BGP instance is restarted either by administratively disabling or enabling the BGP instance, or by rebooting the system with the new configuration.

Because the AS number is defined in the **config>router** context, not in the BGP configuration context, the BGP instance is not aware of the change. Re-examine the plan detailing the autonomous systems, the 7705 SARs belonging to each group, group names, and peering connections.



**Note:** Changing an AS number on a 7705 SAR could cause configuration inconsistencies if associated peer-as values are not also modified as required. At the group and neighbor levels, BGP will re-establish the peer relationships with all peers in the group with the new AS number.

Use the following CLI syntax to change an autonomous system number:

#### CLI syntax:

```
config>router# autonomous-system as-number
config>router# bgp
  group name
    neighbor ip-addr
```

```
peer-as as-number
```

**Example:**

```
config>router# autonomous-system 400
config>router# bgp
config>router>bgp# group headquarters1
config>router>bgp>group# neighbor 10.10.10.103
config>router>bgp>group# peer-as 400
config>router>bgp>group# exit
```

## 6.12.2 Modifying the BGP router ID

Changing the router ID number in the BGP context causes the new value to overwrite the router ID configured on the router level, system interface level, or the value inherited from the MAC address.



**Note:** Changing the router ID on a router could cause configuration inconsistencies if associated values are not also modified.

When configuring a new router ID, protocols are not automatically restarted with the new router ID. The next time a protocol is initialized or reinitialized, the new router ID is used.

To force the new router ID for BGP, issue the **shutdown** and **no shutdown** commands or restart the router.

**Example:**

```
config>router>bgp# router-id 10.0.0.104
config>router>bgp# shutdown
config>router>bgp# router-id 10.0.0.123
config>router>bgp# no shutdown
```

This example displays the BGP configuration with the BGP router ID specified:

```
ALU-B>config>router>bgp# info detail
-----
no shutdown
no description
no always-compare-med
ibgp-multipath load-balance
. . .
router-id 10.0.0.123
-----
ALU-B>config>router>bgp#
```

## 6.12.3 Modifying the router-level router ID

Changing the router ID number in the **config>router** context causes the new value to overwrite the router ID configured on the protocol level, system interface level, or the value inherited from the MAC address.



**Note:** Changing the router ID on a router could cause configuration inconsistencies if associated values are not also modified.

When configuring a new router ID, protocols are not automatically restarted with the new router ID. The next time a protocol is initialized or reinitialized, the new router ID is used. An interim period of time can

occur when different protocols use different router IDs. To force the new router ID, issue the **shutdown** and **no shutdown** commands for each protocol that uses the router ID or restart the entire router.

Use the following CLI syntax to change a router ID:

**CLI syntax:**

```
config>router# router-id ip-address
```

**Example:**

```
config>router# router-id 10.10.10.104
config>router# no shutdown
config>router>bgp# shutdown
config>router>bgp# no shutdown
```

The following example displays the router ID configuration:

```
ALU-A>config>router# info
#-----
# IP Configuration
#-----
  interface "system"
    address 10.10.10.104/8
  exit
  interface "to-103"
    address 10.0.0.104/8
    port 1/1/1
  exit
  autonomous-system 100
  router-id 10.10.10.104
#-----
ALU-B>config>router#
```

## 6.12.4 Deleting a neighbor

In order to delete a neighbor, you must shut down the neighbor before issuing the **no neighbor ip-addr** command.

Use the following CLI syntax to delete a neighbor:

**CLI syntax:**

```
config>router# bgp
  group name
    neighbor ip-address
    shutdown
    exit
  no neighbor ip-address
```

**Example:**

```
config>router# bgp
config>router>bgp# group headquarters1
config>router>bgp>group# neighbor 10.0.0.103
config>router>bgp>group>neighbor# shutdown
config>router>bgp>group>neighbor# exit
config>router>bgp>group# no neighbor 10.0.0.103
```

The following example displays the "headquarters1" configuration with the neighbor 10.0.0.103 removed:

```
ALU-B>config>router>bgp# info
-----
  group "headquarters1"
    description "HQ execs"
      local-address 10.0.0.104
      neighbor 10.0.0.5
        passive
        peer-as 300
      exit
    exit
  exit
-----
ALU-B>config>router>bgp#
```

## 6.12.5 Deleting groups

In order to delete a group, the neighbor configurations must be shut down first. After each neighbor is shut down, you must shut down the group before issuing the **no group name** command.

Use the following CLI syntax to shut down a peer and neighbor and then delete a group:

### CLI syntax:

```
config>router# bgp
  group name
    neighbor ip-address
      shutdown
      exit
    neighbor ip-address
      shutdown
      exit
  shutdown
  exit
no group name
```

### Example:

```
config>router# bgp
config>router>bgp# group headquarters1
config>router>bgp>group# neighbor 10.0.0.105
config>router>bgp>group>neighbor# shutdown
config>router>bgp>group>neighbor# exit
config>router>bgp>group# neighbor 10.0.0.103
config>router>bgp>group>neighbor# shutdown
config>router>bgp>group>neighbor# exit
config>router>bgp>group# shutdown
config>router>bgp>group# exit
config>router>bgp# no group headquarters1
```

If you try to delete the group without shutting it down first, the following message appears:

```
ALU-B>config>router>bgp# no group headquarters1
MINOR: CLI BGP Peer Group should be shutdown before deleted. BGP Peer Group not deleted.
```

## 6.12.6 Editing BGP parameters

You can change existing BGP parameters in the CLI. The changes are applied immediately.

**CLI syntax:**

```
config>router# bgp
  group name
  . . .
  neighbor ip-address
  . . .
```

**Example:**

```
config>router# bgp
```

See [BGP components](#) for a complete list of BGP parameters.

## 6.13 BGP command reference

### 6.13.1 Command hierarchies

- Configuration commands
  - Global BGP commands
  - Group BGP commands
  - Neighbor BGP commands
  - Other BGP-related commands
- Show commands
- Clear commands
- Debug commands

#### 6.13.1.1 Configuration commands

##### 6.13.1.1.1 Global BGP commands

```

config
- router [router-name]
  - [no] bgp
    - [no] add-paths
      - ipv4 send send-limit receive [none]
      - ipv4 send send-limit
      - no ipv4
      - ipv6 send send-limit receive [none]
      - ipv6 send send-limit
      - no ipv6
      - label-ipv4 send send-limit receive [none]
      - label-ipv4 send send-limit
      - no label-ipv4
      - label-ipv6 send send-limit receive [none]
      - label-ipv6 send send-limit
      - no label-ipv6
      - vpn-ipv4 send send-limit receive [none]
      - vpn-ipv4 send send-limit
      - no vpn-ipv4
      - vpn-ipv6 send send-limit receive [none]
      - vpn-ipv6 send send-limit
      - no vpn-ipv6
    - [no] advertise-inactive
    - advertise-ipv6-next-hops [vpn-ipv6] [label-ipv6] [vpn-ipv4] [label-ipv4]
    - no advertise-ipv6-next-hops
    - [no] aggregator-id-zero
    - auth-keychain name
    - no auth-keychain
    - authentication-key {authentication-key | hash-key} [hash | hash2]
    - no authentication-key
    - [no] backup-path [ipv4] [label-ipv4] [ipv6] [label-ipv6]
    - best-path-selection
  
```

```

- always-compare-med [zero | infinity]
- always-compare-med strict-as [zero | infinity]
- no always-compare-med
- as-path-ignore [ipv4] [ipv6] [vpn-ipv4] [vpn-ipv6] [mvpn-ipv4] [label-ipv4]
[label-ipv6]
- no as-path-ignore
- [no] bfd-enable
- cluster cluster-id
- no cluster
- connect-retry seconds
- no connect-retry
- [no] damping
- def-recv-evpn-encap encap-type
- no def-recv-evpn-encap
- description description-string
- no description
- [no] disable-client-reflect
- disable-communities [standard] [extended]
- [no] disable-communities
- [no] disable-fast-external-failover
- dynamic-neighbor-limit peers
- no dynamic-neighbor-limit
- [no] enable-peer-tracking
- [no] enable-rr-vpn-forwarding
- error-handling
  - [no] legacy-mode
  - [no] update-fault-tolerance
- export policy-name [policy-name...(up to 5 max)]
- no export [policy-name]
- extended-nh-encoding [label-ipv4] [vpn-ipv4]
- no extended-nh-encoding
- family [ipv4] [vpn-ipv4] [ipv6] [vpn-ipv6] [mvpn-ipv4] [route-target] [evpn]
[label-ipv4] [label-ipv6] [bgp-ls]
- no family
- [no] graceful-restart
  - stale-routes-time time
  - no stale-routes-time
- [no] group name
  - [no] add-paths
- hold-time seconds [min seconds2]
- no hold-time
- [no] ibgp-multipath
- import policy-name [policy-name...(up to 5 max)]
- no import [policy-name]
- keepalive seconds
- no keepalive
- label-allocation
  - label-ipv6
    - [no] disable-explicit-null
- label-preference value
- no label-preference
- [no] link-state-export-enable
- [no] link-state-import-enable
- local-as as-number [private]
- no local-as
- local-preference local-preference
- no local-preference
- loop-detect {drop-peer | discard-route | ignore-loop | off}
- no loop-detect
- med-out {number | igp-cost}
- no med-out
- min-route-advertisement seconds
- no min-route-advertisement
- multihop ttl-value

```

```

- no multihop
- multipath integer
- no multipath
- [no] mvpn-vrf-import-subtype-new
- next-hop-resolution
  - label-route-transport-tunnel
    - family family
      - resolution {any | filter | disabled}
      - resolution-filter
        - [no] ldp
        - [no] rsvp
        - [no] sr-isis
        - [no] sr-ospf
        - [no] sr-te
    - policy policy-name
    - no policy
- [no] outbound-route-filtering
  - [no] extended-community
    - [no] accept-orf
    - send-orf [comm-id...(up to 32 max)]
    - no send-orf comm-id
- peer-tracking-policy policy-name
- no peer-tracking-policy
- preference preference
- no preference
- rapid-update [mvpn-ipv4] [evpn]
- no rapid-update
- [no] rapid-withdrawal
- [no] remove-private [limited]
- rib-management
  - ipv4
    - route-table-import policy-name
    - no route-table-import
  - ipv6
    - route-table-import policy-name
    - no route-table-import
  - label-ipv4
    - route-table-import policy-name
    - no route-table-import
  - label-ipv6
    - route-table-import policy-name
    - no route-table-import
- route-target-list comm-id [comm-id...(up to 15 max)]
- no route-target-list [comm-id]
- router-id ip-address
- no router-id
- [no] selective-label-ipv4-install
- [no] shutdown
- [no] split-horizon
- [no] vpn-apply-export
- [no] vpn-apply-import

```

### 6.13.1.1.2 Group BGP commands

```

config
- router [router-name]
  - [no] bgp
  - [no] group name
    - [no] add-paths
      - ipv4 send send-limit receive [none]
      - ipv4 send send-limit

```



```

- no ipv4
- ipv6 send send-limit receive [none]
- ipv6 send send-limit
- no ipv6
- label-ipv4 send send-limit receive [none]
- label-ipv4 send send-limit
- no label-ipv4
- label-ipv6 send send-limit receive [none]
- label-ipv6 send send-limit
- no label ipv6
- vpn-ipv4 send send-limit receive [none]
- vpn-ipv4 send send-limit
- no vpn-ipv4
- vpn-ipv6 send send-limit receive [none]
- vpn-ipv6 send send-limit
- no vpn-ipv6
- [no] advertise-inactive
- advertise-ipv6-next-hops [vpn-ipv6] [label-ipv6] [vpn-ipv4] [label-ipv4]
- no advertise-ipv6-next-hops
- [no] aggregator-id-zero
- [no] aigp
- auth-keychain name
- no auth-keychain
- authentication-key {authentication-key | hash-key} [hash | hash2]
- no authentication-key
- [no] bfd-enable
- cluster cluster-id
- no cluster
- connect-retry seconds
- no connect-retry
- [no] damping
- def-recv-evpn-encap encap-type
- no def-recv-evpn-encap
- [no] default-route-target
- description description-string
- no description
- [no] disable-client-reflect
- disable-communities [standard] [extended]
- no disable-communities
- [no] disable-fast-external-failover
- dynamic-neighbor
- [no] prefix ip-prefix/ip-prefix-length
- dynamic-neighbor-limit peers
- no dynamic-neighbor-limit
- [no] enable-peer-tracking
- error-handling
- [no] update-fault-tolerance
- export policy-name [policy-name...(up to 5 max)]
- no export [policy-name]
- extended-nh-encoding [label-ipv4] [vpn-ipv4]
- no extended-nh-encoding
- family [ipv4] [vpn-ipv4] [ipv6] [vpn-ipv6] [mvpn-ipv4] [route-target] [evpn]
[label-ipv4] [label-ipv6] [bgp-ls]
- no family
- [no] graceful-restart
- stale-routes-time time
- no stale-routes-time
- hold-time seconds [min seconds2]
- no hold-time
- import policy-name [policy-name...(up to 5 max)]
- no import [policy-name]
- keepalive seconds
- no keepalive
- label-preference value

```

```

- no label-preference
- local-address ip-address
- no local-address
- local-as as-number [private]
- no local-as
- local-preference local-preference
- no local-preference
- loop-detect {drop-peer | discard-route | ignore-loop | off}
- no loop-detect
- med-out {number | igp-cost}
- no med-out
- min-route-advertisement seconds
- no min-route-advertisement
- multihop ttl-value
- no multihop
- [no] neighbor ip-address
- [no] next-hop-self
- [no] outbound-route-filtering
- [no] extended-community
  - [no] accept-orf
  - send-orf [comm-id...(up to 32 max)]
  - no send-orf comm-id
- [no] passive
- peer-as as-number
- no peer-as
- preference preference
- no preference
- prefix-limit family limit [threshold percentage] [idle-timeout {minutes |
forever} | log-only] [post-import]
- no prefix-limit family
- [no] remove-private [limited]
- [no] selective-label-ipv4-install
- [no] shutdown
- [no] split-horizon
- ttl-security min-ttl-value
- no ttl-security
- [no] vpn-apply-export
- [no] vpn-apply-import

```

### 6.13.1.1.3 Neighbor BGP commands

```

config
- router [router-name]
  - [no] bgp
  - [no] group name
    - [no] neighbor ip-address
      - [no] add-paths
        - ipv4 send send-limit receive [none]
        - ipv4 send send-limit
        - no ipv4
        - ipv6 send send-limit receive [none]
        - ipv6 send send-limit
        - no ipv6
        - label-ipv4 send send-limit receive [none]
        - label-ipv4 send send-limit
        - no label-ipv4
        - label-ipv6 send send-limit receive [none]
        - label-ipv6 send send-limit
        - no label-ipv6
        - vpn-ipv4 send send-limit receive [none]
        - vpn-ipv4 send send-limit

```

```

- no vpn-ipv4
- vpn-ipv6 send send-limit receive [none]
- vpn-ipv6 send send-limit
- no vpn-ipv6
- [no] advertise-inactive
- advertise-ipv6-next-hops [vpn-ipv6] [label-ipv6] [vpn-ipv4] [label-ipv4]
- no advertise-ipv6-next-hops
- [no] aggregator-id-zero
- [no] aigp
- auth-keychain name
- no auth-keychain
- authentication-key {authentication-key | hash-key} [hash | hash2]
- no authentication-key
- [no] bfd-enable
- cluster cluster-id
- no cluster
- connect-retry seconds
- no connect-retry
- [no] damping
- def-recv-evpn-encap encap-type
- no def-recv-evpn-encap
- [no] default-route-target
- description description-string
- no description
- [no] disable-client-reflect
- disable-communities [standard] [extended]
- no disable-communities
- [no] disable-fast-external-failover
- [no] enable-peer-tracking
- error-handling
  - [no] update-fault-tolerance
- export policy-name [policy-name...(up to 5 max)]
- no export [policy-name]
- extended-nh-encoding [label-ipv4] [vpn-ipv4]
- no extended-nh-encoding
- family [ipv4] [vpn-ipv4] [ipv6] [vpn-ipv6] [mvpn-ipv4] [route-target]
[evpn] [label-ipv4] [label-ipv6] [bgp-ls]
- no family
- [no] graceful-restart
  - stale-routes-time time
  - no stale-routes-time
- hold-time seconds [min seconds2]
- no hold-time
- import policy-name [policy-name...(up to 5 max)]
- no import [policy-name]
- keepalive seconds
- no keepalive
- label-preference value
- no label-preference
- local-address ip-address
- no local-address
- local-as as-number [private]
- no local-as
- local-preference local-preference
- no local-preference
- loop-detect {drop-peer | discard-route | ignore-loop | off}
- no loop-detect
- med-out {number | igp-cost}
- no med-out
- min-route-advertisement seconds
- no min-route-advertisement
- multihop ttl-value
- no multihop
- [no] next-hop-self

```

```

- [no] outbound-route-filtering
  - [no] extended-community
    - [no] accept-orf
    - send-orf [comm-id...(up to 32 max)]
    - no send-orf comm-id
  - [no] passive
- peer-as as-number
- no peer-as
- preference preference
- no preference
- prefix-limit family limit [threshold percentage] [idle-timeout {minutes |
forever} | log-only] [post-import]
- no prefix-limit family
- [no] remove-private [limited]
- [no] selective-label-ipv4-install
- [no] shutdown
- [no] split-horizon
- ttl-security min-ttl-value
- no ttl-security
- [no] vpn-apply-export
- [no] vpn-apply-import

```

#### 6.13.1.1.4 Other BGP-related commands

```

config
- router [router-name]
  - aggregate ip-prefix/ip-prefix-length [summary-only]
  - no aggregate ip-prefix/ip-prefix-length
  - autonomous-system as-number
  - no autonomous-system
  - router-id ip-address
  - no router-id

```

#### 6.13.1.2 Show commands

```

show
- router [router-instance]
- router service-name service-name
  - bgp
    - auth-keychain [keychain]
    - damping [ip-prefix[/ip-prefix-length]] [damp-type] [detail] [ipv4]
    - damping [ip-prefix[/ip-prefix-length]] [damp-type] [detail] ipv6
    - damping [ip-prefix[/ip-prefix-length]] [damp-type] [detail] label-ipv4
    - damping [ip-prefix[/ip-prefix-length]] [damp-type] [detail] label-ipv6
    - damping [ip-prefix[/ip-prefix-length]] [damp-type] [detail] vpn-ipv4
    - damping [ip-prefix[/ip-prefix-length]] [damp-type] [detail] vpn-ipv6
    - damping [ip-prefix[/ip-prefix-length]] [damp-type] [detail] mvpn-ipv4
    - group [name] [detail]
    - inter-as-label
    - neighbor [ip-address [detail]]
    - neighbor [as-number [detail]]
    - neighbor [ip-address [family [type mvpn-type]] filter1 [brief]]
    - neighbor [ip-address [[family] filter2]]
    - neighbor [as-number [[family] filter2]]
    - neighbor ip-address orf [filter3]
    - neighbor ip-address graceful-restart
    - neighbor [dynamic]
    - next-hop [family [ip-address] [detail]]

```

```

- paths
- routes [ip-prefix/mask | ip-address]
- routes aspath-regex reg-exp {detail | longer}
- routes aspath-regex reg-exp
- routes aspath-regex reg-exp hunt
- routes bgp-ls [hunt] [node | link | ipv4-prefix [ipv4-prefix/mask-len]]
- routes brief
- routes community comm-id {detail | longer}
- routes community comm-id
- routes community comm-id hunt
- routes detail
- routes hunt [brief]
- routes ipv4 [aspath-regex reg-exp] [community comm-id] [brief] [all]
- routes ipv4 [aspath-regex reg-exp] hunt [community comm-id] [brief] [all]
- routes ipv4 [detail | longer] [aspath-regex reg-exp] [community comm-id] [all]
- routes ipv6 [aspath-regex reg-exp] [community comm-id] [brief] [all]
- routes ipv6 [aspath-regex reg-exp] hunt [community comm-id] [brief] [all]
- routes ipv6 [detail | longer] [aspath-regex reg-exp] [community comm-id] [all]
- routes label-ipv4 [aspath-regex reg-exp] [community comm-id] [brief] [all]
- routes label-ipv4 [aspath-regex reg-exp] hunt [community comm-id] [brief] [all]
- routes label-ipv4 [detail | longer] [aspath-regex reg-exp] [community comm-id]
[all]
- routes label-ipv6 [aspath-regex reg-exp] [community comm-id] [brief] [all]
- routes label-ipv6 [aspath-regex reg-exp] hunt [community comm-id] [brief] [all]
- routes label-ipv6 [detail | longer] [aspath-regex reg-exp] [community comm-id]
[all]
- routes longer
- routes mvpn-ipv4 [aspath-regex reg-exp] [community comm-id] [rd rd] [brief]
[type mvpn-type] [originator-ip ip-address] [source-ip ipv4 address | ipv6 address] [group-
ip ipv4 address | ipv6 address] [source-as as-number]
- routes mvpn-ipv4 [aspath-regex reg-exp] hunt [community comm-id] [rd rd] [brief]
[type mvpn-type] [originator-ip ip-address] [source-ip ipv4 address | ipv6 address] [group-
ip ipv4 address | ipv6 address] [source-as as-number]
- routes mvpn-ipv4 [detail | longer] [aspath-regex reg-exp] [community comm-id]
[rd rd] [type mvpn-type] [originator-ip ip-address] [source-ip ipv4 address | ipv6 address]
[group-ip ipv4 address | ipv6 address] [source-as as-number]
- routes route-target [source-as as-number] [brief] [aspath-regex reg-exp]
[community comm-id]
- routes route-target [rtc-prefix rtc-prefix] [hunt] [brief] [aspath-regex reg-exp]
[community comm-id]
- routes route-target [rtc-prefix rtc-prefix] [aspath-regex reg-exp]
[community comm-id]
- routes route-target [rtc-prefix rtc-prefix] [detail | longer] [aspath-regex reg-
exp] [community comm-id]
- routes vpn-ipv4 [aspath-regex reg-exp] [community comm-id] [rd rd] [brief]
- routes vpn-ipv4 [aspath-regex reg-exp] hunt [community comm-id] [rd rd] [brief]
- routes vpn-ipv4 [detail | longer] [aspath-regex reg-exp] [community comm-id]
[rd rd]
- routes vpn-ipv6 [aspath-regex reg-exp] [community comm-id] [rd rd] [brief]
- routes vpn-ipv6 [aspath-regex reg-exp] hunt [community comm-id] [rd rd] [brief]
- routes vpn-ipv6 [detail | longer] [aspath-regex reg-exp] [community comm-id]
[rd rd]
- summary [all]
- summary [family family] [neighbor ip-address]

```

### 6.13.1.3 Clear commands

```

clear
- router
- bgp

```

```

- flap-statistics [{ip-prefix/mask [neighbor ip-address] | group group-name |
regex reg-exp | policy policy-name}]
- neighbor {ip-address | as as-number | external | all} [soft | soft-inbound]
- neighbor {ip-address | as as-number | external | all} statistics
- neighbor ip-address end-of-rib
- protocol

```

### 6.13.1.4 Debug commands

```

debug
- router
  - bgp
    - events [neighbor ip-address | group name]
    - no events
    - graceful-restart [neighbor ip-address | group name]
    - no graceful-restart
    - keepalive [neighbor ip-address | group name]
    - no keepalive
    - notification [neighbor ip-address | group name]
    - no notification
    - open [neighbor ip-address | group name]
    - no open
    - [no] outbound-route-filtering
    - packets [neighbor ip-address | group name]
    - no packets
    - route-refresh [neighbor ip-address | group name]
    - no route-refresh
    - rtm [neighbor ip-address | group name]
    - no rtm
    - socket [neighbor ip-address | group name]
    - no socket
    - timers [neighbor ip-address | group name]
    - no timers
    - update [neighbor ip-address | group name]
    - no update

```

## 6.13.2 Command descriptions

- [Configuration commands](#)
- [Show commands](#)
- [Clear commands](#)
- [Debug commands](#)

### 6.13.2.1 Configuration commands

- [Configuration commands](#)
- [Other BGP-related commands](#)

#### 6.13.2.1.1 Configuration commands

```
bgp
```

##### Syntax

```
[no] bgp
```

##### Context

```
config>router
```

##### Description

This command creates the BGP protocol instance and BGP configuration context. BGP is administratively enabled upon creation.

The **no** form of the command deletes the BGP protocol instance and removes all configuration parameters for the BGP instance. BGP must be shut down before deleting the BGP instance. An error occurs if BGP is not shut down first.

##### Default

```
no bgp
```

```
add-paths
```

##### Syntax

```
[no] add-paths
```

##### Context

```
config>router>bgp
```

```
config>router>bgp>group
config>router>bgp>group>neighbor
```

## Description

This command creates the add-paths configuration context and enables add-paths to be configured for one or more families on a BGP instance, BGP group, or BGP neighbor. The BGP add-paths capability allows the router to send and/or receive multiple paths per prefix to/from a peer. The **add-paths** command without additional parameters is equivalent to removing add-paths support for all address families, which causes sessions that previously negotiated the add-paths capability for one or more address families to go down and come back up without the add-paths capability.

The **no** form of the command removes add-paths from the configuration of BGP, BGP group, or BGP neighbor, causing sessions established using add-paths to go down and come back up without the add-paths capability.

## Default

no add-paths

## ipv4

## Syntax

```
ipv4 send send-limit receive [none]
```

```
ipv4 send send-limit
```

```
no ipv4
```

## Context

```
config>router>bgp>add-paths
```

```
config>router>bgp>group>add-paths
```

```
config>router>bgp>group>neighbor>add-paths
```

## Description

This command is used to configure the add-paths capability for IPv4 routes (including labeled IPv4 routes on BGP route tunnels). By default, add-paths is not enabled for IPv4 routes.

The maximum number of paths to send per IPv4 prefix is the configured send limit, which is a mandatory parameter. The capability to receive multiple paths per prefix from a peer is configurable using the **receive** keyword, which is optional. If the **receive** keyword is not included in the command, the receive capability is enabled by default. Entering the command without optional parameters enables the ability to both send and receive multiple paths per IPv4 prefix with each peer, and configures the router to send the two best paths per prefix to each peer using the default Add-N, N=2 path selection algorithm.

The BGP **advertise-inactive**, **add-paths**, and **export** policy commands can be configured such that active, non-BGP routes are advertised. For more information, see [Advertise-inactive, add-paths, and export policy interaction](#).

The **no** form of the command removes add-path support for IPv4 routes, causing sessions established using add-paths for IPv4 to go down and come back up without the add-paths capability.



**Default**

no ipv4

**Parameters***send-limit*

the maximum number of paths per IPv4 prefix that are allowed to be advertised to add-path peers. The actual number of advertised routes may be less depending on the next-hop diversity requirement, other configuration options, route policies, and/or route advertisement rules. If the value is none, the router does not negotiate the send capability with respect to IPv4 AFI/SAFI.

**Values** 1 to 16, or none

**receive**

configures the router to negotiate the add-paths receive capability for IPv4 routes with its peers

**none**

the router does not negotiate the add-paths receive capability for IPv4 routes with its peers

**ipv6****Syntax**

```
ipv6 send send-limit receive [none]
```

```
ipv6 send send-limit
```

```
no ipv6
```

**Context**

```
config>router>bgp>add-paths
```

```
config>router>bgp>group>add-paths
```

```
config>router>bgp>group>neighbor>add-paths
```

**Description**

This command is used to configure the add-paths capability for unlabeled IPv6 unicast routes. By default, add-paths is not enabled for unlabeled IPv6 unicast routes.

The maximum number of unlabeled unicast paths to send per IPv6 prefix is the configured send limit, which is a mandatory parameter. The capability to receive multiple unlabeled IPv6 unicast paths per prefix from a peer is configurable using the **receive** keyword, which is optional. If the **receive** keyword is not included in the command, the receive capability is enabled by default.

The **no** form of the command removes add-path support for unlabeled IPv6 unicast routes, causing sessions established using add-paths for unlabeled IPv6 unicast to go down and come back up without the add-paths capability.

**Default**

no ipv6

## Parameters

### *send-limit*

the maximum number of paths per unlabeled IPv6 unicast prefix that are allowed to be advertised to add-path peers. (The actual number of advertised routes may be less.) If the value is none, the router does not negotiate the send capability with respect to IPv6 AFI/SAFI.

**Values** 1 to 16, or none

### **receive**

the router negotiates to receive multiple unlabeled unicast routes per IPv6 prefix

### **none**

the router does not negotiate to receive multiple unlabeled unicast routes per IPv6 prefix

## label-ipv4

## Syntax

**label-ipv4 send *send-limit* receive [none]**

**label-ipv4 send *send-limit***

**no label-ipv4**

## Context

config>router>bgp>add-paths

config>router>bgp>group>add-paths

config>router>bgp>group>neighbor>add-paths

## Description

This command is used to configure the add-paths capability for labeled unicast IPv4 routes. By default, add-paths is not enabled for labeled unicast IPv4 routes.

The maximum number of labeled unicast paths per IPv4 prefix to send is the configured *send-limit*, which is a mandatory parameter. The capability to receive multiple labeled unicast paths per prefix from a peer is configurable using the **receive** keyword, which is optional. If the **receive** keyword is not included in the command, receive capability is enabled by default.

The **no** form of the command disables add-paths support for labeled unicast IPv4 routes, causing sessions established using add-paths for labeled unicast IPv4 to go down and come back up without the add-paths capability.

## Default

no label-ipv4

## Parameters

### *send-limit*

the maximum number of paths per labeled unicast IPv4 prefix that are allowed to be advertised to add-paths peers. The actual number of advertised routes may be less. If the

value is none, the router does not negotiate the send capability with respect to label-IPv4 AFI/SAFI.

**Values** 1 to 16, none

#### **receive**

configures the router to negotiate to receive multiple labeled unicast routes per IPv4 prefix

#### **none**

the router does not negotiate to receive multiple labeled unicast routes per IPv4 prefix

## label-ipv6

### Syntax

**label-ipv6 send** *send-limit* **receive** [none]

**label-ipv6 send** *send-limit*

**no label-ipv6**

### Context

config>router>bgp>add-paths

config>router>bgp>group>add-paths

config>router>bgp>group>neighbor>add-paths

### Description

This command is used to configure the add-paths capability for labeled unicast IPv6 routes. By default, add-paths is not enabled for labeled unicast IPv6 routes.

The maximum number of labeled unicast paths per IPv6 prefix to send is the configured *send-limit*, which is a mandatory parameter. The capability to receive multiple labeled unicast paths per prefix from a peer is configurable using the **receive** keyword, which is optional. If the **receive** keyword is not included in the command, receive capability is enabled by default.

The **no** form of the command disables add-paths support for labeled unicast IPv6 routes, causing sessions established using add-paths for labeled unicast IPv6 to go down and come back up without the add-paths capability.

### Default

no label-ipv6

### Parameters

*send-limit*

the maximum number of paths per labeled unicast IPv6 prefix that are allowed to be advertised to add-paths peers. The actual number of advertised routes may be less. If the value is none, the router does not negotiate the send capability with respect to label-IPv6 AFI/SAFI.

**Values** 1 to 16, none

**receive**

configures the router to negotiate to receive multiple labeled unicast routes per IPv6 prefix

**none**

the router does not negotiate to receive multiple labeled unicast routes per IPv6 prefix

## vpn-ipv4

### Syntax

```
vpn-ipv4 send send-limit receive [none]
```

```
vpn-ipv4 send send-limit
```

```
no vpn-ipv4
```

### Context

```
config>router>bgp>add-paths
```

```
config>router>bgp>group>add-paths
```

```
config>router>bgp>group>neighbor>add-paths
```

### Description

This command is used to configure the add-paths capability for VPN-IPv4 routes. By default, add-paths is not enabled for VPN-IPv4 routes.

The maximum number of paths to send per VPN-IPv4 prefix is the configured send limit, which is a mandatory parameter. The capability to receive multiple paths per prefix from a peer is configurable using the **receive** keyword, which is optional. If the **receive** keyword is not included in the command, the receive capability is enabled by default.

The BGP **advertise-inactive**, **add-paths**, and **export** policy commands can be configured such that active, non-BGP routes are advertised. For more information, see [Advertise-inactive, add-paths, and export policy interaction](#).

The **no** form of the command removes add-path support for VPN-IPv4 routes, causing sessions established using add-paths for VPN-IPv4 to go down and come back up without the add-paths capability.

### Default

```
no vpn-ipv4
```

### Parameters

*send-limit*

the maximum number of paths per VPN-IPv4 prefix that are allowed to be advertised to add-path peers. The actual number of advertised routes may be less depending on the next-hop diversity requirement, other configuration options, route policies, and/or route advertisement rules. If the value is none, the router does not negotiate the send capability with respect to VPN-IPv4 AFI/SAFI.

**Values** 1 to 16, or none

**receive**

configures the router to negotiate the add-paths receive capability for VPN-IPv4 routes with its peers

**none**

the router does not negotiate the add-paths receive capability for VPN-IPv4 routes with its peers

## vpn-ipv6

### Syntax

```
vpn-ipv6 send send-limit receive [none]
```

```
vpn-ipv6 send send-limit
```

```
no vpn-ipv6
```

### Context

```
config>router>bgp>add-paths
```

```
config>router>bgp>group>add-paths
```

```
config>router>bgp>group>neighbor>add-paths
```

### Description

This command is used to configure the add-paths capability for VPN-IPv6 routes. By default, add-paths is not enabled for VPN-IPv6 routes.

The maximum number of paths to send per VPN-IPv6 prefix is the configured send limit, which is a mandatory parameter. The capability to receive multiple paths per prefix from a peer is configurable using the **receive** keyword, which is optional. If the **receive** keyword is not included in the command, the receive capability is enabled by default.

The BGP **advertise-inactive**, **add-paths**, and **export** policy commands can be configured such that active, non-BGP routes are advertised. For more information, see [Advertise-inactive, add-paths, and export policy interaction](#).

The **no** form of the command removes add-path support for VPN-IPv6 routes, causing sessions established using add-paths for VPN-IPv6 to go down and come back up without the add-paths capability.

### Default

```
no vpn-ipv6
```

### Parameters

*send-limit*

the maximum number of paths per VPN-IPv6 prefix that are allowed to be advertised to add-path peers. The actual number of advertised routes may be less depending on the next-hop diversity requirement, other configuration options, route policies, and/or route advertisement rules. If the value is none, the router does not negotiate the send capability with respect to VPN-IPv6 AFI/SAFI.

**Values** 1 to 16, or none

**receive**

configures the router to negotiate the add-paths receive capability for VPN-IPv6 routes with its peers

**none**

the router does not negotiate the add-paths receive capability for VPN-IPv6 routes with its peers

## advertise-inactive

### Syntax

**[no] advertise-inactive**

### Context

config>router>bgp

config>router>bgp>group

config>router>bgp>group>neighbor

### Description

This command enables the advertising of inactive BGP routes to other BGP peers. By default, BGP only advertises BGP routes to other BGP peers if a given BGP route is chosen by the route table manager as the most preferred route within the system and is active in the forwarding plane. This command allows system administrators to advertise a BGP route even though it is not the most preferred route within the system for a given destination.

The BGP **advertise-inactive**, **add-paths**, and **export** policy commands can be configured such that active, non-BGP routes are advertised. For more information, see [Advertise-inactive, add-paths, and export policy interaction](#).

The **no** form of the command disables the advertising of inactive BGP routers to other BGP peers.

### Default

no advertise-inactive

## advertise-ipv6-next-hops

### Syntax

**advertise-ipv6-next-hops [vpn-ipv6] [label-ipv6] [vpn-ip4] [label-ipv4]**

**no advertise-ipv6-next-hops**

### Context

config>router>bgp

config>router>bgp>group

```
config>router>bgp>group>neighbor
```

## Description

This command enables BGP next hops to be set to a global IPv6 address. This command applies to a BGP session established on top of an IPv6 transport tunnel. BGP routes belonging to the specified address families can be advertised with a global IPv6 address when originated or when next-hop-self is applied. For VPN-IPv4 or label-IPv4 routes, the remote peer must advertise the necessary extended next-hop encoding capability.

This command has no effect on routes advertised to IPv4 peers.

By default, this command is disabled at all BGP context levels. When the command is disabled, the following applies:

- If a VPN-IPv6 route or label-IPv6 route must be originated or advertised with next-hop-self to an IPv6 transport peer, the route is advertised with the IPv4 system address as the BGP next hop (encoded as an IPv4-mapped IPv6 address).
- If a VPN-IPv4 route or label-IPv4 route must be originated or advertised with next-hop-self, or if an appropriate extended next-hop encoding capability was not received from the remote peer, the route is advertised with the IPv4 system address as the BGP next hop.
- If a VPN-IPv4 route or label-IPv4 route is matched by a BGP export policy entry that tries to change the next hop to an IPv6 address, or if an appropriate extended next-hop encoding capability was not received from the remote peer, the route is handled as though it was rejected by the policy entry.

The **no** form of this command disables the setting of next hops to a global IPv6 address.

## Default

```
no advertise-ipv6-next-hops
```

## Parameters

### vpn-ipv6

VPN-IPv6 routes are advertised to IPv6 transport peers with an IPv6 address as the BGP next hop in cases of route origination or next-hop-self (configured or automatic)

### label-ipv6

label-IPv6 routes are advertised to IPv6 transport peers with an IPv6 address as the BGP next hop in cases of route origination or next-hop-self (configured or automatic)

### vpn-ipv4

VPN-IPv4 routes are advertised to IPv6 transport peers with an IPv6 address as the BGP next hop in cases of route origination or next-hop-self (configured or automatic) and export policies can change the BGP next hop of a VPN-IPv4 route to an IPv6 address

### label-ipv4

label-IPv4 routes are advertised to IPv6 transport peers with an IPv6 address as the BGP next hop in cases of route origination or next-hop-self (configured or automatic) and export policies can change the BGP next hop of a label-IPv4 route to an IPv6 address

## aggregator-id-zero

### Syntax

[no] aggregator-id-zero

### Context

```
config>router>bgp
config>router>bgp>group
config>router>bgp>group>neighbor
```

### Description

This command is used to set the router ID in the BGP aggregator path attribute to 0 when BGP aggregates routes. This prevents different routers within an AS from creating aggregate routes that contain different AS paths.

When BGP is aggregating routes, it adds the aggregator path attribute to the BGP Update messages. By default, BGP adds the AS number and router ID to the aggregator path attribute.

When this command is enabled, BGP adds only the router ID (set to 0) to the aggregator path attribute. This command is used at the group level to revert to the value defined under the global level, and this command is used at the neighbor level to revert to the value defined under the group level.

The **no** form of the command used at the global level reverts to the default, where BGP adds the AS number and router ID to the aggregator path attribute.

The **no** form of the command used at the group level reverts to the value defined at the global level.

The **no** form of the command used at the neighbor level reverts to the value defined at the group level.

### Default

no aggregator-id-zero

## aigp

### Syntax

[no] aigp

### Context

```
config>router>bgp>group
config>router>bgp>group>neighbor
```

### Description

This command enables or disables accumulated IGP (AIGP) metric path attribute support with one or more BGP peers. BGP path selection among routes with an associated AIGP metric is based on the end-to-end IGP metrics of the different BGP paths, even when these BGP paths span more than one AS and IGP instance.



If AIGP is disabled, the AIGP attribute is removed from advertised routes, if present, and is ignored in received routes.

### Default

no aigp

## auth-keychain

### Syntax

**auth-keychain** *name*

**no auth-keychain**

### Context

config>router>bgp

config>router>bgp>group

config>router>bgp>group>neighbor

### Description

This command associates an authentication keychain with the BGP protocol. The keychain is a collection of keys used to authenticate BGP messages from remote neighbors. The keychain allows the rollover of authentication keys during the lifetime of a session and also supports stronger authentication algorithms than clear text and MD5.

The keychain must already be defined in the **config>system>security>keychain** context.

Either the **authentication-key** command or the **auth-keychain** command can be used by BGP, but both cannot be supported at the same time. If both commands are configured, the **auth-keychain** configuration will be applied and the **authentication-key** command will be ignored.

By default, authentication is not enabled.

### Default

no auth-keychain

### Parameters

*name*

the name of an existing keychain, up to 32 characters

## authentication-key

### Syntax

**authentication-key** {*authentication-key* | *hash-key*} [**hash** | **hash2**]

**no authentication-key**

## Context

```
config>router>bgp
config>router>bgp>group
config>router>bgp>group>neighbor
```

## Description

This command configures the BGP authentication key.

Authentication is performed between neighboring routers before setting up the BGP session by verifying the password. Authentication is performed using the MD5 message-based digest.

The authentication *key* can be any combination of ASCII characters up to 255 characters long.

The TCP MD5 key information used to securely communicate with a BGP peer is retained even after the connection has closed, allowing connectionless RST packets to be sent with the proper authentication data.

Either the **authentication-key** command or the **auth-keychain** command can be used by BGP, but both cannot be supported at the same time. If both commands are configured, the **auth-keychain** configuration will be applied and the **authentication-key** command will be ignored.

The **no** form of the command reverts to the default value.

## Default

MD5 authentication is disabled by default

## Parameters

### *authentication-key*

the authentication key. The key can be any combination of ASCII characters up to 255 characters in length (unencrypted). If spaces are used in the string, the entire string must be enclosed in quotation marks (" ").

### *hash-key*

the hash key. The key can be any combination of ASCII characters up to 342 characters in length (encrypted). If spaces are used in the string, the entire string must be enclosed in quotation marks (" "). This is useful when a user must configure the parameter, but for security purposes, the actual unencrypted key value is not provided.

### **hash**

specifies that the key is entered in an encrypted form. If the **hash** parameter is not used, the key is assumed to be in a non-encrypted, clear text form. For security, all keys are stored in encrypted form in the configuration file with the **hash** parameter specified.

### **hash2**

specifies that the key is entered in a more complex encrypted form. If the **hash2** parameter is not used, the less encrypted **hash** form is assumed.

## backup-path

### Syntax

```
[no] backup-path [ipv4] [label-ipv4] [ipv6] [label-ipv6]
```

### Context

```
config>router>bgp
```

### Description

This command enables BGP fast reroute (FRR) with prefix-independent convergence (PIC), allowing for the creation of a backup path for IPv4, label-IPv4, or IPv6 learned prefixes belonging to the router. Multiple paths must be received for a prefix in order to take advantage of this feature.

When a prefix has a backup path, and its primary paths fail, the affected traffic is rapidly diverted to the backup path without waiting for control plane reconvergence to occur. The time to reroute the traffic is independent of the number of prefixes sharing the primary or backup paths.

The **no** form of the command disables BGP FRR with PIC.

### Default

```
no backup-path
```

### Parameters

#### ipv4

enables a backup path for IPv4 BGP learned prefixes

#### label-ipv4

enables a backup path for labeled IPv4 BGP learned prefixes

#### ipv6

enables a backup path for IPv6 BGP learned prefixes

#### label-ipv6

enables a backup path for labeled IPv6 BGP learned prefixes

## best-path-selection

### Syntax

```
best-path-selection
```

### Context

```
config>router>bgp
```

### Description

This command enables path selection configuration.

## always-compare-med

### Syntax

```
always-compare-med [zero | infinity]
always-compare-med strict-as [zero | infinity]
no always-compare-med
```

### Context

```
config>router>bgp>path-selection
```

### Description

This command specifies how the Multi-Exit Discriminator (MED) path attribute is used in the BGP route selection process.

If this command is used without the **strict-as** option, the MEDs of two paths are always compared even if the paths have a different neighbor AS.

If the **strict-as** option is used, the MEDs of two paths are compared only if they come from the same neighboring AS.

The **zero** and **infinity** options specify how to treat paths that do not have a MED attribute; for example, **always-compare-med zero** means that if one path is missing a MED attribute, it is treated as though it had a MED attribute with the value of 0. If neither option is specified, the **zero** option is implied.

The **no** form of the command means that only the MEDs of paths that have the same neighbor AS are compared.

### Default

```
no always-compare-med
```

### Parameters

#### zero

specifies that for routes learned without a MED attribute, a zero (0) value is used in the MED comparison. The routes with the lowest metric are the most preferred.

#### infinity

specifies that for routes learned without a MED attribute, a value of infinity (4294967295) is used in the MED comparison. This, in effect, makes these routes the least desirable.

#### strict-as

specifies that the MEDs of two paths are compared only if they come from the same neighboring AS

## as-path-ignore

### Syntax

```
[ipv4] [ipv6] [vpn-ipv4] [vpn-ipv6] [mvpn-ipv4] [label-ipv4] [label-ipv6]
```

## no as-path-ignore

### Context

```
config>router>bgp>path-selection
```

### Description

This command specifies whether the AS path is used to determine the best BGP route.

If this command is enabled, the AS paths of incoming routes are not used in the route selection process.

When **as-path-ignore** is used without specifying any keywords, all keywords are configured.

The **no** form of the command means that the AS paths of incoming routes are used to determine the best BGP route.

### Default

```
no as-path-ignore
```

### Parameters

#### ipv4

specifies that the AS path length will be ignored for all IPv4 routes

#### ipv6

specifies that the AS path length will be ignored for all IPv6 routes

#### vpn-ipv4

specifies that the AS path length will be ignored for all VPN-IPv4 routes

#### vpn-ipv6

specifies that the AS path length will be ignored for all VPN-IPv6 routes

#### mvpn-ipv4

specifies that the AS path length will be ignored for all MVPN-IPv4 routes

#### label-ipv4

specifies that the AS path length will be ignored for all labeled IPv4 routes

#### label-ipv6

specifies that the AS path length will be ignored for all labeled IPv6 routes

## bfd-enable

### Syntax

```
[no] bfd-enable
```

### Context

```
config>router>bgp
```

```
config>router>bgp>group
```

```
config>router>bgp>group>neighbor
```

## Description

This command enables the use of bidirectional forwarding (BFD) to control the state of the associated protocol interface. By enabling BFD on a given protocol interface, the state of the protocol interface is tied to the state of the BFD session between the local node and the remote node. The parameters used for BFD are set via the BFD command under the IP interface.

The **no** form of this command removes BFD from the associated IGP/BGP protocol adjacency.

## Default

no bfd-enable

## cluster

## Syntax

**cluster** *cluster-id*

**no cluster**

## Context

config>router>bgp

config>router>bgp>group

config>router>bgp>group>neighbor

## Description

This command configures the cluster ID for a route reflector server.

Route reflectors are used to reduce the number of IBGP sessions required within an AS. Normally, all BGP speakers within an AS must have a BGP peering with every other BGP speaker in the AS. A route reflector and its clients form a cluster. Peers that are not part of the cluster are considered to be non-clients.

When a route reflector receives a route, it must first select the best path from all the paths received. If the route was received from a non-client peer, then the route reflector sends the route to all clients in the cluster. If the route came from a client peer, the route reflector sends the route to all non-client peers and to all client peers except the originator.

For redundancy, a cluster can have multiple route reflectors.

The **no** form of the command deletes the cluster ID and effectively disables route reflection for the given group.

## Default

no cluster

## Parameters

*cluster-id*

the route reflector cluster ID, expressed in dotted-decimal notation

**Values** any 32-bit number in dotted-decimal notation (0.0.0.1 to 255.255.255.255)

## connect-retry

### Syntax

**connect-retry** *seconds*

**no connect-retry**

### Context

config>router>bgp

config>router>bgp>group

config>router>bgp>group>neighbor

### Description

This command configures the BGP connect retry timer value in seconds. When this timer expires, BGP tries to reconnect to the configured peer. This configuration parameter can be set at three levels: global level (applies to all peers), group level (applies to all peers in group) or neighbor level (only applies to specified peer). The most specific value is used.

The **no** form of the command used at the global level reverts to the default value.

The **no** form of the command used at the group level reverts to the value defined at the global level.

The **no** form of the command used at the neighbor level reverts to the value defined at the group level.

### Default

120 s

### Parameters

*seconds*

the BGP connect retry timer value, in seconds, expressed as a decimal integer

**Values** 1 to 65535

## damping

### Syntax

[no] **damping**

### Context

config>router>bgp

config>router>bgp>group

config>router>bgp>group>neighbor

## Description

This command enables BGP route damping for learned routes that are defined within the route policy. Use damping to reduce the number of update messages sent between BGP peers and reduce the load on peers without affecting the route convergence time for stable routes. Damping parameters are set at the route policy level. See 7705 SAR Router Configuration Guide, "Route Policy Command Reference".

The **no** form of the command disables learned route damping.

The **no** form of the command used at the group level reverts to the value defined at the global level.

The **no** form of the command used at the neighbor level reverts to the value defined at the group level.

## Default

no damping

## def-recv-evpn-encap

## Syntax

**def-recv-evpn-encap** *encap-type*

**no def-recv-evpn-encap**

## Context

config>router>bgp

config>router>bgp>group

config>router>bgp>group>neighbor

## Description

This command defines how BGP treats a received EVPN route without RFC 5512 BGP encapsulation extended community. If no encapsulation is received, BGP validates the route as MPLS.

## Default

no def-recv-evpn-encap

## Parameters

*encap-type*

specifies the default encapsulation value in the case where no RFC 5512 extended community is received in the incoming BGP-EVPN route

**Values**    mpls

## default-route-target

## Syntax

**[no] default-route-target**



## Context

```
config>router>bgp>group
config>router>bgp>group>neighbor
```

## Description

This command advertises the default RTC route toward the selected peers.

The default RTC route is a special route that has a prefix length of zero. Sending the default RTC route to a peer conveys a request to receive all VPN routes from that peer, whether or not they match the route target extended community. Advertising the default RTC route to a peer does not suppress other more specific RTC routes from being sent to that peer.

The **no** form of the command blocks the router from advertising the default RTC route.

## Default

```
no default-route-target
```

## description

## Syntax

```
description description-string
no description
```

## Context

```
config>router>bgp
config>router>bgp>group
config>router>bgp>group>neighbor
```

## Description

This command creates a text description stored in the configuration file for a configuration context.

The **no** form of the command removes the description string from the context.

## Default

No description is associated with the configuration context

## Parameters

*string*

the description character string. Allowed values are any string up to 80 characters long composed of printable, 7-bit ASCII characters. If the string contains special characters (such as #, \$, or spaces), the entire string must be enclosed within double quotes.

## disable-client-reflect

### Syntax

```
[no] disable-client-reflect
```

### Context

```
config>router>bgp  
config>router>bgp>group  
config>router>bgp>group>neighbor
```

### Description

This command disables the reflection of routes by the route reflector to the clients in a specific group or neighbor.

This command only disables the reflection of routes from other client peers. Routes learned from non-client peers are still reflected to all clients.

The **no** form re-enables client reflection of routes.

### Default

```
no disable-client-reflect
```

## disable-communities

### Syntax

```
disable-communities [standard] [extended]  
no disable-communities
```

### Context

```
config>router>bgp  
config>router>bgp>group  
config>router>bgp>group>neighbor
```

### Description

This command configures BGP to disable sending communities.

### Default

```
no disable-communities
```

### Parameters

**standard**

specifies standard communities that existed before VPRNs or RFC 2547

**extended**

specifies BGP communities that were expanded after the concept of RFC 2547 was introduced, to include handling the route target from the VRF

**disable-fast-external-failover****Syntax**

[no] **disable-fast-external-failover**

**Context**

config>router>bgp

config>router>bgp>group

config>router>bgp>group>neighbor

**Description**

This command configures BGP fast external failover.

For EBGP neighbors, this feature controls whether the router should drop an EBGP session immediately upon an interface-down event, or whether the BGP session should be kept up until the hold-time expires.

When fast external failover is disabled, the EBGP session stays up until the hold-time expires or the interface comes back up. If the BGP routes become unreachable as a result of the down IP interface, BGP withdraws the unavailable route immediately from other peers.

**Default**

no disable-communities

**dynamic-neighbor****Syntax**

**dynamic-neighbor**

**Context**

config>router>bgp>group

**Description**

This command enables the context to configure dynamic BGP sessions for a peer group.

**prefix****Syntax**

[no] **prefix** *ip-prefix/ip-prefix-length*

## Context

```
config>router>bgp>group>dynamic-neighbor
```

## Description

This command configures a prefix to accept dynamic BGP sessions, which are sessions from source IP addresses that do not match any configured (static) neighbor addresses.

A dynamic session is associated with the group having the longest-match prefix entry for the source IP address of the peer. There is no limit on the number of prefixes that can be configured. The group association determines local parameters that apply to the session, including the local AS, local IP address, MP-BGP families, and import and export policies.

The **no** form of this command removes a prefix entry.

## Default

n/a

## Parameters

*ip-prefix/ip-prefix-length*

specifies an IPv4 or IPv6 prefix from which to accept dynamic BGP sessions

## dynamic-neighbor-limit

## Syntax

```
dynamic-neighbor-limit peers
```

```
no dynamic-neighbor-limit
```

## Context

```
config>router>bgp
```

```
config>router>bgp>group
```

## Description

This command configures the maximum number of dynamic BGP sessions that will be accepted from remote peers associated with the global BGP instance or a specific peer group. If accepting a new dynamic session would cause either the group limit or the global limit to be exceeded, the new session attempt is rejected and a notification message is sent back to the remote peer.

The **no** form of this command removes the limit on the number of dynamic sessions.

## Default

no dynamic-neighbor-limit

## Parameters

*peers*

specifies the maximum number of dynamic BGP sessions

**Values** 1 to 320: 7705 SAR-18, 7705 SAR-8 Shelf V2  
1 to 128: 7705 SAR-X  
1 to 64: 7705 SAR-A, 7705 SAR-Ax, 7705 SAR-H, 7705 SAR-Hc,  
7705 SAR-M, 7705 SAR-Wx

## enable-peer-tracking

### Syntax

[no] enable-peer-tracking

### Context

```
config>router>bgp
config>router>bgp>group
config>router>bgp>group>neighbor
```

### Description

This command enables BGP peer tracking. BGP peer tracking allows a BGP peer to be dropped immediately if the route used to resolve the BGP peer address is removed from the IP routing table and there is no alternative available. The BGP peer will not wait for the hold timer to expire; therefore, the BGP reconvergence process is accelerated.

The **no** form of the command disables peer tracking.

### Default

no enable-peer-tracking

## enable-rr-vpn-forwarding

### Syntax

[no] enable-rr-vpn-forwarding

### Context

```
config>router>bgp
```

### Description

This command enables a route reflector of VPN-IP routes to be deployed in the data path between two BGP peers (a peer X and a peer Y) in a next-hop resolution.

All received VPN-IP routes are imported into a table that is used to resolve the BGP next hops. The next hop of a VPN-IP route that is imported from peer X and selected as having the best path by the table is advertised to peer Y (the [next-hop-self](#) command must be set for peer Y or a next-hop action must be used in an export policy that is applied to peer Y in order for the next-hop to be advertised to peer Y).

A new VPN service label value is then allocated for the VPN-IP route. This new label is advertised to peer Y and a label swap operation is then performed by the IOM.

The **no** form of the command disables the advertising of a new VPN service label from one BGP peer to another.

### Default

no enable-rr-vpn-forwarding

## error-handling

### Syntax

**error-handling**

### Context

config>router>bgp

config>router>bgp>group

config>router>bgp>group>neighbor

### Description

This command enables the context to configure BGP error handling.

## legacy-mode

### Syntax

[no] **legacy-mode**

### Context

config>router>bgp>error-handling

### Description

This command configures the legacy fault tolerance mode for BGP error handling. When enabled, configuration for fault tolerance can be enabled or disabled at the BGP global, group, or neighbor level and applied to sessions at that level with the **update-fault-tolerance** command. When disabled, **update-fault-tolerance** configurations are ignored and updated fault protection is automatically applied to all BGP sessions.

### Default

no legacy-mode

## update-fault-tolerance

### Syntax

[no] **update-fault-tolerance**

### Context

config>router>bgp>error-handling

config>router>bgp>group>error-handling

config>router>bgp>group>neighbor>error-handling

### Description

This command enables updated fault tolerance for handling a wide range of BGP Update message errors. When enabled, the system uses the "treat-as-withdraw" and "attribute-discard" approach to error handling as described in RFC 7606 as long as there are no length errors that prevent all of the NLRI fields from being correctly identified and parsed.

### Default

no update-fault-tolerance

## export

### Syntax

**export** *policy-name* [*policy-name...*(up to 5 max)]

**no export** [*policy-name*]

### Context

config>router>bgp

config>router>bgp>group

config>router>bgp>group>neighbor

### Description

This command specifies the export route policy used to determine which routes are advertised to peers. Route policies are configured in the **config>router>policy-options** context. See the section on "Route Policy" in the 7705 SAR Router Configuration Guide.

This configuration parameter can be set at three levels: global level (applies to all peers), group level (applies to all peers in group) or neighbor level (only applies to specified peer). The most specific level is used.

When multiple policy names are specified, the policies are evaluated in the order in which they are specified. A maximum of five (5) policy names can be configured. The first policy that matches is applied.

When multiple export commands are issued, the last command entered overrides the previous command.

When no export policies are specified, BGP routes are advertised and non-BGP routes are not advertised (by default).

The BGP **advertise-inactive**, **add-paths**, and **export** policy commands can be configured such that active, non-BGP routes are advertised. For more information, see [Advertise-inactive, add-paths, and export policy interaction](#).

The **no** form of the command removes the policy association with the BGP instance. To remove association of all policies, use the **no export** command without arguments.

## Default

no export

## Parameters

*policy-name*

the route policy name. Allowed values are any string up to 32 characters long composed of printable, 7-bit ASCII characters. If the string contains special characters (such as #, \$, or spaces), the entire string must be enclosed within double quotes.

## extended-nh-encoding

### Syntax

**extended-nh-encoding** [label-ipv4] [vpn-ipv4]

**no extended-nh-encoding**

### Context

config>router>bgp

config>router>bgp>group

config>router>bgp>group>neighbor

### Description

This command configures BGP to advertise (at session OPEN) the capability to receive label-IPv4 routes or VPN-IPv4 routes from peers. The peers should not send these routes unless they receive notification of this capability.

If the 7705 SAR receives a label-IPv4 or VPN-IPv4 route from a peer to which it did not advertise the necessary capability, the UPDATE message is considered malformed, causing either a session reset or treat-as-withdraw behavior, depending on the error handling settings.

The **no** form of this command at the global level disables the extended next-hop encoding configuration. The **no** form of the command at the group level reverts to the configuration at the global level. The **no** form of the command at the neighbor level reverts to the configuration at the group level.

### Default

no extended-nh-encoding



## Parameters

### label-ipv4

BGP advertises an extended next-hop encoding capability for NLRI AFI=1, NLRI SAFI=4, and next-hop AFI=2

### vpn-ipv4

BGP advertises an extended next-hop encoding capability for NLRI AFI=1, NLRI SAFI=128, and next-hop AFI=2

## family

## Syntax

**family** [ipv4] [vpn-ipv4] [ipv6] [vpn-ipv6] [mvpn-ipv4] [route-target] [evpn] [[label-ipv4] [label-ipv6] [bgp-ls]

**no family**

## Context

```
config>router>bgp
```

```
config>router>bgp>group
```

```
config>router>bgp>group>neighbor
```

## Description

This command specifies the address family or families to be supported over BGP peerings in the base router. One or more address families can be specified in a single command. To add an address family to the currently configured families, reissue the command and include the current families in addition to any new family.

The **no** form of the command removes the specified address family from the associated BGP peerings. If an address family is not specified, the supported address family is reset to the default.

## Default

ipv4

## Parameters

### ipv4

supports IPv4 routing information

### vpn-ipv4

exchanges VPN-IPv4 routing information

### ipv6

supports IPv6 routing information

### vpn-ipv6

exchanges VPN-IPv6 routing information

**mvpn-ipv4**

exchanges MVPN-IPv4 routing information

**route-target**

exchanges RTC routing information

**evpn**

exchanges EVPN routing information

**label-ipv4**

supports labeled IPv4 routing information

**label-ipv6**

supports labeled IPv6 routing information

**bgp-ls**

supports BGP-LS routing information

## graceful-restart

### Syntax

**[no] graceful-restart**

### Context

config>router>bgp

config>router>bgp>group

config>router>bgp>group>neighbor

### Description

The command enables procedures for BGP graceful restart (GR) helper—the receiving router role, as defined in the RFC 4724 standard—for all received IPv4 and VPN-IPv4 routes. In order for helper mode to be available for a particular address family, both peers must signal GR support for the address family during capability negotiation.

When a neighbor covered by GR helper mode restarts its control plane, the forwarding of traffic can continue uninterrupted while the session is being re-established and routes are relearned.

The **no** form of the command disables graceful restart and removes all graceful restart configurations in the BGP instance.

### Default

no graceful-restart

## stale-routes-time

### Syntax

**stale-routes-time** *time*

## no stale-routes-time

### Context

```
config>router>bgp>graceful-restart
config>router>bgp>group>graceful-restart
config>router>bgp>group>neighbor>graceful-restart
```

### Description

This command configures the maximum amount of time in seconds that stale routes should be maintained after a graceful restart is initiated.

The **no** form of the command resets the stale routes time back to the default value.

### Default

360 s

### Parameters

*time*

the amount of time that stale routes should be maintained after a graceful restart is initiated

**Values** 1 to 3600 s

## group

### Syntax

```
[no] group name
```

### Context

```
config>router>bgp
```

### Description

This command creates a context to configure a BGP peer group.

The **no** form of the command deletes the specified peer group and all configurations associated with the peer group. The group must be shut down before it can be deleted.

### Default

no group

### Parameters

*name*

the peer group name. Allowed values are any string up to 32 characters long composed of printable, 7-bit ASCII characters. If the string contains special characters (such as #, \$, or spaces), the entire string must be enclosed within double quotes.

## hold-time

### Syntax

**hold-time** *seconds* [*min seconds2*]

**no hold-time**

### Context

config>router>bgp

config>router>bgp>group

config>router>bgp>group>neighbor

### Description

This command configures the BGP hold time, expressed in seconds.

The BGP hold time specifies the maximum time BGP waits between successive messages (either Keepalive or Update) from its peer, before closing the connection. This configuration parameter can be set at three levels: global level (applies to all peers), group level (applies to all peers in group) or neighbor level (only applies to specified peer). The most specific value is used.

The **min** option ensures a minimum hold time for a BGP session that is independent of the hold time advertised in a received Open message.

Even though the 7705 SAR implementation allows setting the **keepalive** time separately, the configured **keepalive** timer is overridden by the **hold-time** value under the following circumstances.

- If the specified **hold-time** is less than the configured **keepalive** time, then the operational **keepalive** time is set to a third of the **hold-time**; the configured **keepalive** time is not changed.
- If the **hold-time** is set to 0, then the operational value of the **keepalive** time is set to 0; the configured **keepalive** time is not changed. This means that the connection with the peer is up permanently and no keepalive packets are sent to the peer.

The **no** form of the command used at the global level reverts to the default value.

The **no** form of the command used at the group level reverts to the value defined at the global level.

The **no** form of the command used at the neighbor level reverts to the value defined at the group level.

### Default

90 s

### Parameters

*seconds*

the hold time, in seconds, expressed as a decimal integer. A value of 0 indicates that the connection to the peer is permanently up.

**Values** 0, 3 to 65535

*seconds2*

the minimum hold time, in seconds, that will be accepted for the session. If the peer proposes a hold time lower than this value, the session attempt will be rejected.

**Values** 0, 3 to 65535

## ibgp-multipath

### Syntax

**[no] ibgp-multipath**

### Context

config>router>bgp

### Description

This command enables IBGP multipath load balancing when adding BGP routes to the route table if the route resolving the BGP next-hop offers multiple next-hops.

The **no** form of the command disables the IBGP multipath load balancing feature.

### Default

no ibgp-multipath

## import

### Syntax

**import** *policy-name* [*policy-name...*(up to 5 max)]

**no import** [*policy-name*]

### Context

config>router>bgp

config>router>bgp>group

config>router>bgp>group>neighbor

### Description

This command specifies the import route policy to be used to determine which routes are accepted from peers. Route policies are configured in the **config>router>policy-options** context. See the section on "Route Policy" in the 7705 SAR Router Configuration Guide.

This configuration parameter can be set at three levels: global level (applies to all peers), group level (applies to all peers in group) or neighbor level (only applies to specified peer). The most specific level is used.

When multiple policy names are specified, the policies are evaluated in the order in which they are specified. A maximum of five (5) policy names can be specified. The first policy that matches is applied.

When multiple **import** commands are issued, the last command entered will override the previous command.

When an import policy is not specified, BGP routes are accepted by default.

The **no** form of the command removes the policy association with the BGP instance. To remove association of all policies, use **no import** without arguments.

## Default

no import

## Parameters

*policy-name*

the route policy name. Allowed values are any string up to 32 characters long composed of printable, 7-bit ASCII characters. If the string contains special characters (such as #, \$, or spaces), the entire string must be enclosed within double quotes.

## keepalive

### Syntax

**keepalive** *seconds*

**no keepalive**

### Context

config>router>bgp

config>router>bgp>group

config>router>bgp>group>neighbor

### Description

This command configures the BGP keepalive timer. A Keepalive message is sent every time this timer expires.

The **keepalive** parameter can be set at three levels: global level (applies to all peers), group level (applies to all peers in group) or neighbor level (only applies to specified peer). The most specific value is used. The **keepalive** value is generally one-third of the **hold-time** interval. Even though the 7705 SAR implementation allows the **keepalive** value and the **hold-time** interval to be independently set, under the following circumstances, the configured **keepalive** value is overridden by the **hold-time** value.

- If the specified **keepalive** value is greater than the configured **hold-time**, then the specified value is ignored, and the **keepalive value** is set to one third of the current **hold-time** value.
- If the specified **hold-time** interval is less than the configured **keepalive** value, then the **keepalive** value is reset to one third of the specified **hold-time** interval.
- If the **hold-time** interval is set to 0, then the configured value of the **keepalive** value is ignored. This means that the connection with the peer is up permanently and no **keepalive** packets are sent to the peer.

The **no** form of the command used at the global level reverts to the default value.

The **no** form of the command used at the group level reverts to the value defined at the global level.

The **no** form of the command used at the neighbor level reverts to the value defined at the group level.

### Default

30 s

### Parameters

*seconds*

the keepalive timer, in seconds, expressed as a decimal integer

**Values** 0 to 21845

## label-allocation

### Syntax

**label-allocation**

### Context

config>router>bgp

### Description

This command enables the context to control MPLS label allocation to BGP routes.

## label-ipv6

### Syntax

**label-ipv6**

### Context

config>router>bgp>label-allocation

### Description

This command enables the context to control MPLS label allocation to BGP-LU IPv6 routes.

## disable-explicit-null

### Syntax

**[no] disable-explicit-null**

### Context

config>router>bgp>label-allocation>label-ipv6

## Description

This command configures whether the 7705 SAR advertises IPv6 explicit null (value 2) in advertised 6PE routes. Label-ipv6 routes cannot be resolved by another BGP route. By default, 6PE routes always advertise the IPv6 explicit null value.

When the command is disabled (**no disable-explicit-null**), the following applies:

- if the router is required to act as the BGP next hop of a label-IPv6 route that it is advertising, it sets the BGP label value to IPv6 explicit null (value 2), forcing a pop behavior for received packets
- received label-IPv6 routes never create tunnels in the TTM that can be used to resolve other BGP routes with an IPv6 next hop

When the command is enabled (**disable-explicit-null**), the following applies:

- if the router is required to act as the BGP next hop of a label-IPv6 route that it is advertising, it sets the BGP label value to a proper value in the dynamic label range and programs a pop or swap operation for that label, depending on the origin of the route and any import policy actions that apply to the route
- received label-IPv6 routes that have a prefix length of 128 bits are automatically installed in the TTM so that they can be used to resolve other unlabeled IPv6 BGP routes with an IPv6 next hop
- the label-IPv6 routes used for ECMP toward an IPv6 destination cannot be a mix of routes with regular label values and routes with IPv6 explicit null label values

Changing the configuration of this command does not cause the BGP sessions on the base router to reset.

## Default

no disable-explicit-null

## label-preference

## Syntax

**label-preference** *value*

**no label-preference**

## Context

config>router>bgp

config>router>bgp>group

config>router>bgp>group>neighbor

## Description

This command configures the route preference for routes learned from labeled unicast peers.

This command can be configured at three levels:

- global level – applies to all peers
- group level – applies to all peers in the peer group
- neighbor level – applies only to the specified peer

The most specific value is used.



The lower the preference *value*, the higher the chance of the route being the active route.

The **no** form of the command used at the global level reverts to the default *value* of 170.

The **no** form of the command used at the group level reverts to the value defined at the global level.

The **no** form of the command used at the neighbor level reverts to the value defined at the group level.

### Default

no label-preference

### Parameters

*value*

specifies the route preference value

**Values** 1 to 255

**Default** 170 (global level)

## link-state-export-enable

### Syntax

[no] link-state-export-enable

### Context

config>router>bgp

### Description

This command enables the export of link-state information from the BGP-LS address family into the local Traffic Engineering Database (TED).

The **no** form of this command disables the export of link-state information into the TED.

### Default

no link-state-export-enable

## link-state-import-enable

### Syntax

[no] link-state-import-enable

### Context

config>router>bgp

## Description

This command enables the import of link-state information into the BGP-LS address family for advertisement to other BGP neighbors.

The **no** form of this command disables the import of link-state information into the BGP-LS address family.

## Default

no link-state-import-enable

## local-address

## Syntax

**local-address** *ip-address*

**no local-address**

## Context

config>router>bgp>group

config>router>bgp>group>neighbor

## Description

This command configures the local IP address used by the group or neighbor when communicating with BGP peers.

Outgoing connections use the **local-address** as the source of the TCP connection when initiating connections with a peer.

When a local address is not specified at the group level, the 7705 SAR uses the system IP address when communicating with IBGP peers and uses the interface address for directly connected EBGP peers. When a local address is not specified at the neighbor level, the neighbor uses the value defined at the group level.

The **no** form of the command removes the configured local address for BGP.

## Default

no local-address

## Parameters

*ip-address*

the local address. The allowed value is a valid routable IP address on the router, either an interface or system IP address.

## local-as

## Syntax

**local-as** *as-number* [**private**]

## no local-as

### Context

```
config>router>bgp
config>router>bgp>group
config>router>bgp>group>neighbor
```

### Description

This command configures a BGP virtual autonomous system (AS) number.

In addition to the AS number configured for BGP in the **config>router>autonomous- system** context, a virtual (local) AS number is configured. The virtual AS number is added to the as-path attribute before the router's AS number makes the virtual AS the second AS in the AS path.

This configuration parameter can be set at three levels: global level (applies to all peers), group level (applies to all peers in group) or neighbor level (only applies to specified peer). By specifying this parameter at each neighbor level, it is possible to have a separate AS number per EBGP session.

When a command is entered multiple times for the same AS, the last command entered is used in the configuration. The **private** attribute can be added or removed dynamically by reissuing the command.

Changing the local AS at the global level in an active BGP instance causes the BGP instance to restart with the new local AS number.

Changing the local AS at the group level in an active BGP instance causes BGP to re-establish the peer relationships with all peers in the group with the new local AS number.

Changing the local AS at the neighbor level in an active BGP instance causes BGP to re-establish the peer relationship with the new local AS number.

This is an optional command and can be used in the following situation.

Example: Provider router P is moved from AS1 to AS2. The customer router that is connected to P, however, is configured to belong to AS1. To avoid reconfiguring the customer router, the **local-as** value on router P can be set to AS1. Thus, router P adds AS1 to the as-path message for routes it advertises to the customer router.

The **no** form of the command used at the global level will remove any virtual AS number configured.

The **no** form of the command used at the group level reverts to the value defined at the global level.

The **no** form of the command used at the neighbor level reverts to the value defined at the group level.

### Default

no local-as

### Parameters

*as-number*

the virtual autonomous system number expressed as a decimal integer

**Values** 1 to 4294967295

**private**

specifies that the local AS is hidden in paths learned from the peering

## local-preference

### Syntax

**local-preference** *local-preference*

**no local-preference**

### Context

config>router>bgp

config>router>bgp>group

config>router>bgp>group>neighbor

### Description

This command configures the default value of the BGP local preference attribute if it is not already specified in incoming routes.

This value is used if the BGP route arrives from a BGP peer without the **local-preference** integer set.

The specified value can be overridden by any value set via a route policy. This configuration parameter can be set at three levels: global level (applies to all peers), group level (applies to all peers in group) or neighbor level (only applies to specified peer). The most specific value is used.

The **no** form of the command at the global level specifies that incoming routes with local preference set are not overridden and routes arriving without local preference set are interpreted as if the route had a local preference value of 100.

The **no** form of the command used at the group level reverts to the value defined at the global level.

The **no** form of the command used at the neighbor level reverts to the value defined at the group level.

### Default

no local-preference

### Parameters

*local-preference*

the local preference value to be used as the override value, expressed as a decimal integer

**Values** 0 to 4294967295

## loop-detect

### Syntax

**loop-detect** {**drop-peer** | **discard-route** | **ignore-loop** | **off**}

**no loop-detect**

## Context

```
config>router>bgp
config>router>bgp>group
config>router>bgp>group>neighbor
```

## Description

This command configures how the BGP peer session handles loop detection in the AS path.

This configuration parameter can be set at three levels: global level (applies to all peers), group level (applies to all peers in group) or neighbor level (only applies to specified peer). The most specific value is used.

When applied to an ongoing BGP peer session, this command does not take effect until the BGP peer session is re-established.

The **no** form of the command used at the global level reverts to the default (**ignore-loop**).

The **no** form of the command used at the group level reverts to the value defined at the global level.

The **no** form of the command used at the neighbor level reverts to the value defined at the group level.

## Default

ignore-loop

## Parameters

### drop-peer

sends a notification to the remote peer and drops the session

### discard-route

discards routes received from a peer with the same AS number as the router itself. This option prevents routes looped back to the router from being added to the routing information base and consuming memory. When this option is changed, the change will not be active for an established peer until the connection is re-established for the peer.

### ignore-loop

ignores routes with loops in the AS path, but maintains peering

### off

disables loop detection

## med-out

## Syntax

```
med-out {number | igp-cost}
```

```
no med-out
```

## Context

```
config>router>bgp
config>router>bgp>group
```

```
config>router>bgp>group>neighbor
```

### Description

This command is used to advertise the Multi-Exit Discriminator (MED) to BGP peers and assign the path value if the MED is not already set via a route policy (the specified value can be overridden by a MED value that is set via a route policy using the **metric** command. See the 7705 SAR Router Configuration Guide, "Route Policy Configuration Commands").

The **no** form of the command used at the global level reverts to the default where the MED is not advertised.

The **no** form of the command used at the group level reverts to the value defined at the global level.

The **no** form of the command used at the neighbor level reverts to the value defined at the group level.

### Default

no med-out (the MED is not advertised)

### Parameters

*number*

the MED path value

**Values** 0 to 4294967295

**igp-cost**

the MED is set to the IGP cost of the IP prefix that is defined via a route policy

## min-route-advertisement

### Syntax

**min-route-advertisement** *seconds*

**no min-route-advertisement**

### Context

```
config>router>bgp
```

```
config>router>bgp>group
```

```
config>router>bgp>group>neighbor
```

### Description

This command configures the minimum interval, in seconds, at which a prefix can be advertised to a peer.

This configuration parameter can be set at three levels: global level (applies to all peers), group level (applies to all peers in group) or neighbor level (only applies to specified peer). The most specific value is used.

The **no** form of the command used at the global level reverts to the default.

The **no** form of the command used at the group level reverts to the value defined at the global level.

The **no** form of the command used at the neighbor level reverts to the value defined at the group level.

**Default**

30 s

**Parameters***seconds*

the minimum route advertising interval, in seconds, expressed as a decimal integer

**Values** 2 to 255**multihop****Syntax****multihop** *ttl-value***no multihop****Context**

config&gt;router&gt;bgp

config&gt;router&gt;bgp&gt;group

config&gt;router&gt;bgp&gt;group&gt;neighbor

**Description**

This command configures the time to live (TTL) value at an originating BGP peer. The TTL value is entered in the IP header of packets that are sent to a terminating BGP peer that is multiple hops away.

The **no** form of the command used at the global level reverts to the default value.

The **no** form of the command used at the group level reverts to the value defined at the global level.

The **no** form of the command used at the neighbor level reverts to the value defined at the group level.

**Default**

1 – EBGp peers are directly connected

64 – IBGP peer

**Parameters***ttl-value*

the TTL value that will be entered in the IP header of packets that are sent to a terminating BGP peer that is multiple hops away

**Values** 1 to 255

## multipath

### Syntax

**multipath** *integer*

**no multipath**

### Context

config>router>bgp

### Description

This command enables BGP multipath.

When multipath is enabled, BGP load-shares traffic across multiple links. Multipath can be configured to load-share traffic across a maximum of 16 routes. If the equal-cost routes available are more than the configured value, then routes with the lowest next-hop IP address value are chosen.

This configuration parameter is set at the global level (applies to all peers).

Multipath is disabled if the value is set to 1. When multipath is disabled and multiple equal-cost routes are available, the route with the lowest next-hop IP address will be used.

The **no** form of the command reverts to the default where **multipath** is disabled.

### Default

no multipath

### Parameters

*integer*

the number of equal-cost routes to use for multipath routing. If more equal-cost routes exist than the configured value, routes with the lowest next-hop value are chosen. Setting this value to 1 disables multipath.

**Values** 1 to 16

## mvpn-vrf-import-subtype-new

### Syntax

**[no] mvpn-vrf-import-subtype-new**

### Context

config>router>bgp

### Description

This command enables the type/subtype in advertised routes to be encoded as 0x010b (extended community type: transitive IPv4-address-specific VRF route import).



The **no** form of the command encodes the type/subtype as 0x010a (extended community type: transitive IPv4-address-specific L2VPN identifier), in order to preserve backwards compatibility.

### Default

```
no mvpn-vrf-import-subtype-new
```

## next-hop-resolution

### Syntax

```
next-hop-resolution
```

### Context

```
config>router>bgp
```

### Description

This command enables the context to configure next-hop resolution parameters.

## label-route-transport-tunnel

### Syntax

```
label-route-transport-tunnel
```

### Context

```
config>router>bgp>next-hop-res
```

### Description

This command enables the context to configure options for the next-hop resolution of BGP labeled routes (VPN-IP and labeled unicast) using tunnels in the tunnel table manager (TTM). The context allows the selection of different tunnel resolution options for different types of BGP labeled routes: labeled unicast IPv4, labeled unicast IPv6, and VPN-IP routes (both VPN-IPv4 and VPN-IPv6).

By default (if this context and the **resolution** options are not configured), these routes resolve only to LDP tunnels.

## family

### Syntax

```
family family
```

### Context

```
config>router>bgp>next-hop-res>lbl-rt-tunn
```

## Description

This command configures the address family context for configuring next-hop resolution of BGP label routes.

## Parameters

*family*

specifies and enters the context for configuring next-hop-resolution options

**Values** vpn, label-ipv4, label-ipv6

## resolution

## Syntax

**resolution** {**any** | **filter** | **disabled**}

## Context

config>router>bgp>next-hop-res>lbl-rt-tunn>family

## Description

This command configures the resolution mode in the resolution of BGP label routes using tunnels to BGP peers.

If the **resolution** option is explicitly set to **disabled**, the default binding to LDP tunnels resumes. If **resolution** is set to **any**, any supported tunnel type is allowed and the selection is based on the lowest numerical TTM preference value. The **resolution** must be set to **filter** to activate the list of tunnel types configured under the **resolution-filter** command.

## Parameters

**any**

enables the binding to any supported tunnel type in the BGP label route context following TTM preference

**filter**

enables the binding to the subset of tunnel types configured under **resolution-filter**

**disabled**

disables the resolution of BGP label routes using tunnels to BGP peers

## resolution-filter

## Syntax

**resolution-filter**

## Context

config>router>bgp>next-hop-res>lbl-rt-tunn>family

## Description

This command enables the context to configure the subset of tunnel types that can be used in the resolution of BGP label routes.

The following tunnel types are supported in a BGP label route context (in order of preference from most to least preferred): RSVP, SR-TE, LDP, SR-OSPF, and SR-ISIS.

Only the tunnel types specified using the **resolution-filter** command are selected, following the TTM preference.

The **resolution** must be set to **filter** to activate the list of tunnel types configured under **resolution-filter**.

## ldp

### Syntax

[no] ldp

### Context

```
config>router>bgp>next-hop-res>lbl-rt-tunn>family>res-filter
```

## Description

This command selects LDP tunneling for next-hop resolution.

The **ldp** command instructs BGP to search for an LDP LSP with a FEC prefix corresponding to the address of the BGP next hop.

## rsvp

### Syntax

[no] rsvp

### Context

```
config>router>bgp>next-hop-res>lbl-rt-tunn>family>res-filter
```

## Description

This command selects RSVP tunneling for next-hop resolution.

The **rsvp** command instructs BGP to search for the best metric RSVP-TE LSP to the BGP next-hop address. The address can correspond to the system interface or to another loopback interface used by the BGP instance on the remote node. The LSP metric is provided by MPLS in the tunnel table. If there are multiple RSVP-TE LSPs with the same lowest metric, BGP selects the LSP with the lowest tunnel ID.

## sr-isis

### Syntax

[no] sr-isis

## Context

```
config>router>bgp>next-hop-res>lbl-rt-tunn>family>res-filter
```

## Description

This command selects the Segment Routing (SR) tunnel type programmed by an IS-IS instance in the TTM for next-hop resolution.

When the **sr-isis** command is enabled, a tunnel to the BGP next hop is selected in the TTM from the lowest-numbered IS-IS instance.

## sr-ospf

## Syntax

```
[no] sr-ospf
```

## Context

```
config>router>bgp>next-hop-res>lbl-rt-tunn>family>res-filter
```

## Description

This command selects the Segment Routing (SR) tunnel type programmed by OSPF in the TTM for next-hop resolution.

When the **sr-ospf** command is enabled, a tunnel to the BGP next hop is selected in the TTM from OSPF.

## sr-te

## Syntax

```
[no] sr-te
```

## Context

```
config>router>bgp>next-hop-res>lbl-rt-tunn>family>res-filter
```

## Description

This command selects the Segment Routing (SR) tunnel type programmed by a traffic engineered (TE) instance in the TTM for next-hop resolution.

The **sr-te** command initiates a search for the best metric SR-TE LSP to the BGP next-hop address. The LSP metric is provided by MPLS in the tunnel table. If there are multiple SR-TE LSPs with the same lowest metric, BGP selects the LSP with the lowest tunnel ID.

## policy

## Syntax

```
policy policy-name
```

## no policy

### Context

```
config>router>bgp>next-hop-resolution
```

### Description

This command specifies the name of a policy statement to use with the BGP next-hop resolution process. The policy controls which IP routes in the RTM are eligible to resolve the BGP next-hop addresses of IPv4 and IPv6 routes. The policy has no effect on the resolution of BGP next hops to MPLS tunnels. If a BGP next hop of an IPv4 or IPv6 route is resolved in the RTM and the longest matching route for the next-hop address is an IP route that is rejected by the policy, the route is unresolved; if the route is accepted by the policy, it becomes the resolving route.

If the **no** form of the command is used, the default next-hop-resolution policy is to use the longest matching active route in the RTM that is not a BGP route or an aggregate route.

### Default

```
no policy
```

### Parameters

*policy-name*

specifies an existing route policy name. Route policies are configured in the **config>router>policy-options** context.

## neighbor

### Syntax

```
[no] neighbor ip-address
```

### Context

```
config>router>bgp>group
```

### Description

This command creates a BGP peer/neighbor instance within the context of the BGP group.

This command can be issued repeatedly to create multiple peers and their associated configurations.

The **no** form of the command is used to remove the specified neighbor and the entire configuration associated with the neighbor. The neighbor must be administratively shut down before it can be deleted. If the neighbor is not shut down, the command will not result in any action except a warning message on the CLI indicating that the neighbor is still administratively up.

### Default

```
no neighbor – no neighbors are defined
```

## Parameters

*ip-address*

the IP address of the BGP neighbor

## split-horizon

### Syntax

**[no] split-horizon**

### Context

config>router>bgp

config>router>bgp>group

config>router>bgp>group>neighbor

### Description

This command enables the use of split horizon. Split horizon prevents routes from being reflected back to a peer that sends the best route. It applies to routes of all address families and to any type of sending peer: EBGP and IBGP.

By default, split horizon is not enabled, meaning that no effort is taken to prevent a best route from being reflected back to the sending peer.



**Note:** Enabling split horizon may have a detrimental impact on peer and route scaling; therefore, operators are encouraged to use it only when absolutely needed.

### Default

no split-horizon

## next-hop-self

### Syntax

**[no] next-hop-self**

### Context

config>router>bgp>group

config>router>bgp>group>neighbor

### Description

This command configures the group or neighbor to always set the next-hop path attribute to its own physical interface when advertising to a peer.

This command is primarily used to avoid third-party route advertisements when connected to a multi-access network.

The **no** form of the command used at the group level allows third-party route advertisements in a multi-access network.

The **no** form of the command used at the neighbor level reverts to the value defined at the group level.

### Default

no next-hop-self

## outbound-route-filtering

### Syntax

[no] **outbound-route-filtering**

### Context

config>router>bgp

config>router>bgp>group

config>router>bgp>group>neighbor

### Description

This command opens the configuration tree for sending or accepting BGP filter lists from peers (outbound route filtering (ORF)).

### Default

no outbound-route-filtering

## extended-community

### Syntax

[no] **extended-community**

### Context

config>router>bgp>outbound-route-filtering

config>router>bgp>group>outbound-route-filtering

config>router>bgp>group>neighbor>outbound-route-filtering

### Description

This command opens the configuration tree for sending or accepting extended-community-based BGP filters. In order for the **no** version of the command to work, all sub-commands (**send-orf**, **accept-orf**) must be removed first.

### Default

no extended-community

## accept-orf

### Syntax

[no] **accept-orf**

### Context

config>router>bgp>outbound-route-filtering>extended-community

config>router>bgp>group>outbound-route-filtering>extended-community

config>router>bgp>group>neighbor>outbound-route-filtering>extended-community

### Description

This command instructs the router to negotiate the receive capability in the BGP outbound route filtering (ORF) negotiation with a peer, and to accept filters that the peer wishes to send.

The **no** form of the command causes the router to remove the accept capability in the BGP ORF negotiation with a peer, and to clear any existing ORF filters that are currently in place.

### Default

no accept-orf

## send-orf

### Syntax

**send-orf** [*comm-id...*(up to 32 max)]

**no send-orf** [*comm-id*]

### Context

config>router>bgp>outbound-route-filtering>extended-community

config>router>bgp>group>outbound-route-filtering>extended-community

config>router>bgp>group>neighbor>outbound-route-filtering>extended-community

### Description

This command instructs the router to negotiate the send capability in the BGP outbound route filtering (ORF) negotiation with a peer.

This command also causes the router to send a community filter, prefix filter, or AS path filter configured as an inbound filter on the BGP session to its peer as an ORF Action ADD.

The **no** form of this command causes the router to remove the send capability in the BGP ORF negotiation with a peer.

The **no** form also causes the router to send an ORF remove action for a community filter, prefix filter, or AS path filter configured as an inbound filter on the BGP session to its peer.



If the *comm-id* parameters are not exclusively route target communities, the router will extract appropriate route targets and use those. If, for some reason, the *comm-id* parameters specified contain no route targets, the router will not send an ORF.

### Default

no send-orf

### Parameters

*comm-id*

any community policy that consists exclusively of route target extended communities. If the policy is not specified, then the ORF policy is automatically generated from configured route target lists, accepted client route target ORFs, and locally configured route targets.

**Values**    *comm-id*: target: {*ip-addr:comm-val* | *as-number:ext-comm-val*}  
*ip-addr*: a.b.c.d  
*comm-val*: 0 to 65535  
*as-number*: 0 to 65535  
*ext-comm-val*: 0 to 4294967295

## passive

### Syntax

[no] passive

### Context

```
config>router>bgp>group  
config>router>bgp>group>neighbor
```

### Description

This command enables and disables passive mode for the BGP group or neighbor. When in passive mode, BGP will not attempt to actively connect to the configured BGP peers but responds only when it receives a connect open request from the peer.

The **no** form of the command used at the group level disables passive mode, and BGP actively attempts to connect to its peers.

The **no** form of the command used at the neighbor level reverts to the value defined at the group level.

### Default

no passive

## peer-as

### Syntax

**peer-as** *as-number*

**no peer-as**

### Context

config>router>bgp>group

config>router>bgp>group>neighbor

### Description

This command configures the autonomous system number for the remote peer. The peer AS number must be configured for each configured peer.

For IBGP peers, the peer AS number must be the same as the autonomous system number of this router configured under the global level.

This command may be configured under the group level for all neighbors in a particular group.

### Default

no AS numbers are defined

### Parameters

*as-number*

the autonomous system number, expressed as a decimal integer

**Values** 1 to 4294967295

## peer-tracking-policy

### Syntax

**peer-tracking-policy** *policy-name*

**no peer-tracking-policy**

### Context

config>router>bgp

### Description

This command specifies the name of a policy statement to use with the BGP peer-tracking function on the BGP sessions where the **peer-tracking-policy** command is enabled. The policy controls which IP routes in the RTM are eligible to indicate reachability of IPv4 and IPv6 BGP neighbor addresses. If the longest matching route in the RTM for a BGP neighbor address is an IP route that is rejected by the policy or a BGP route accepted by the policy, or if there is no matching route, the neighbor is considered unreachable

and BGP tears down the peering session and keeps it in the idle state until a valid route is available again and accepted by the policy.

The **no** form of the command defaults to using the longest matching active route in the RTM that is not an aggregate route.

## Default

no peer-tracking-policy

## Parameters

*policy-name*

specifies an existing route policy name. Route policies are configured in the **config>router>policy-options** context.

## preference

## Syntax

**preference** *preference*

**no preference**

## Context

config>router>bgp

config>router>bgp>group

config>router>bgp>group>neighbor

## Description

This command configures the route preference for routes learned from the configured peers.

This configuration parameter can be set at three levels: global level (applies to all peers), group level (applies to all peers in group) or neighbor level (only applies to specified peer). The most specific value is used.

The lower the preference, the higher the chance of the route being the active route. The 7705 SAR assigns the highest default preference to BGP routes as compared to routes that are direct, static, or learned via MPLS or OSPF.

The **no** form of the command used at the global level reverts to the default value.

The **no** form of the command used at the group level reverts to the value defined at the global level.

The **no** form of the command used at the neighbor level reverts to the value defined at the group level.

## Default

170

## Parameters

*preference*

the route preference, expressed as a decimal integer

**Values** 1 to 255

## prefix-limit

### Syntax

```
prefix-limit family limit [threshold percentage] [idle-timeout {minutes | forever} | log-only] [post-import]  
no prefix-limit family
```

### Context

```
config>router>bgp>group  
config>router>bgp>group>neighbor
```

### Description

This command configures the maximum number of BGP routes that can be received from a peer before administrative action is taken. The administrative action can be the generation of a log event or the taking down of the session. If a session is taken down, it can be brought back up automatically after an idle-timeout period or it can be configured to stay down (**forever**) until the operator performs a reset.

The **prefix-limit** command allows each address family to have its own limit; a set of address family limits can be applied to one neighbor or to all neighbors in a group.

The **no** form of the command removes the **prefix-limit**.

### Default

No prefix limits for any address family

### Parameters

*family*

specifies the address family to which the limit applies

**Values** ipv4, vpn-ipv4, ipv6, vpn-ipv6, mvpn-ipv4, route-target, label-ipv4, label-ipv6, evpn, bgp-ls

*limit*

specifies the number of routes that can be learned from a peer, expressed as a decimal integer

**Values** 1 to 4294967295

*percentage*

specifies the threshold value, as a percentage, that triggers a warning message to be sent

**Values** 1 to 100

*minutes*

specifies the length of time, in minutes, before automatically re-establishing a session

**Values** 1 to 1024

**forever**

specifies that the session is re-established only after the **clear router bgp** command is executed

**log-only**

enables a warning message to be sent at the specified threshold percentage and also when the limit is reached. However, the BGP session is not taken down.

**post-import**

specifies that the limit should be applied only to the number of routes that are accepted by import policies

## rapid-update

**Syntax**

**rapid-update** [mvpn-ipv4] [evpn]

**no rapid-update**

**Context**

config>router>bgp

**Description**

This command enables BGP rapid update for specified address families.

The **no** form of the command disables BGP rapid update.

**Default**

no rapid-update

**Parameters**

**mvpn-ipv4**

specifies BGP rapid update for the MVPN-IPv4 family

**evpn**

specifies BGP rapid update for the EVPN family

## rapid-withdrawal

**Syntax**

[no] **rapid-withdrawal**

**Context**

config>router>bgp

## Description

This command disables the delay on issuing BGP withdrawals.

By default, BGP withdrawals (messages containing the routes that are no longer valid) are delayed up to the **min-route-advertisement** to allow for efficient packing of BGP Update messages. However, when the **rapid-withdrawal** command is enabled, the delay on sending BGP withdrawals is disabled.

The **no** form of the command returns BGP withdrawal processing to its default behavior.

## Default

no rapid-withdrawal

## remove-private

## Syntax

[no] **remove-private** [limited]

## Context

config>router>bgp

config>router>bgp>group

config>router>bgp>group>neighbor

## Description

This command allows all private AS numbers to be removed from the AS path before advertising them to BGP peers. The **no** form of the command includes private AS numbers in the AS path attribute.

If the **limited** keyword is included, only the leading private ASNs up to the first public ASN are removed.

When the **remove-private** parameter is set at the global level, it applies to all peers regardless of group or neighbor configuration. When the parameter is set at the group level, it applies to all peers in the group regardless of the neighbor configuration.

The 7705 SAR recognizes the set of AS numbers that are defined by IANA as private. These are AS numbers in the range 64512 through 65535, inclusive.

The **no** form of the command used at the global level reverts to the default value.

The **no** form of the command used at the group level reverts to the value defined at the global level.

The **no** form of the command used at the neighbor level reverts to the value defined at the group level.

## Default

no remove-private

## rib-management

## Syntax

**rib-management**

## Context

```
config>router>bgp
```

## Description

This command enables the context to configure RIB management parameters. Under the RIB management context are options for **ipv4**, **ipv6**, **label-ipv4**, and **label-ipv6**.

## route-table-import

## Syntax

```
route-table-import policy-name
```

```
no route-table-import
```

## Context

```
config>router>bgp>rib-management>ipv4
```

```
config>router>bgp>rib-management>ipv6
```

```
config>router>bgp>rib-management>label-ipv4
```

```
config>router>bgp>rib-management>label-ipv6
```

## Description

This command specifies the name of a route policy to control the importation of active routes from the IP route table into one of the BGP RIBs.

If the **route-table-import** command is not configured, or if the command refers to an empty policy, all non-BGP routes from the IP route table are imported into the applicable RIB.

If the **route-table-import** command is configured, routes that are dropped or rejected by the configured policy are not installed in the associated RIB. Rejected routes cannot be advertised to BGP peers associated with the RIB, but they can still be used to resolve BGP next hops of routes in that RIB. If the active route for a prefix is rejected by the **route-table-import** policy, the best BGP route for that prefix in the BGP RIB can be advertised to peers as though it is used.

Aggregate routes are always imported into the applicable RIB, independent of the **route-table-import** policy.

Route modifications specified in the actions of a **route-table-import** policy are ignored and have no effect on the imported routes.

## Default

```
no route-table-import
```

## Parameters

*policy-name*

specifies the name of a policy statement; the policy statement must already have been created

## route-target-list

### Syntax

**route-target-list** *comm-id* [*comm-id* ..(up to 15 max)]

**no route-target-list** [*comm-id*]

### Context

config>router>bgp

### Description

This command specifies the route targets to be accepted from and advertised to peers. If the **route-target-list** is a non-null list, only routes with one or more of the specified route targets are accepted from or advertised to peers.

This command is only applicable if the router is a route-reflector server.

The **route-target-list** is assigned at the global level and applies to all peers connected to the system.

The **no** form of the command with a specified route target community removes the community from the **route-target-list**.

The **no** form of the command entered without a route target community removes all communities from the list.

### Default

no route-target-list

### Parameters

*comm-id*

the route target community

**Values** target:{*ip-addr:comm-val* | *2byte-asnumber:ext-comm-val* | *4-byte-asnumber:comm-val*}

Where:

*ip-addr* a.b.c.d

*comm-val* 0 to 65535

*2-byte-asnumber* 0 to 65535

*ext-comm-val* 0 to 4294967295

*4-byte-asnumber* 0 to 4294967295

## router-id

### Syntax

**router-id** *ip-address*



## no router-id

### Context

```
config>router>bgp
```

### Description

This command specifies the router ID to be used with this BGP instance. If no router ID is specified, the system interface IP address is used.

Changing the BGP router ID on an active BGP instance causes the BGP instance to restart with the new router ID. The router ID must be set to a valid host address.

### Default

```
no router-id
```

### Parameters

*ip-address*

the router ID, expressed in dotted-decimal notation. The allowed value is a valid routable IP address on the router, either an interface or system IP address. It is highly recommended that this address be the system IP address.

**Values** a.b.c.d

## selective-label-ipv4-install

### Syntax

```
[no] selective-label-ipv4-install
```

### Context

```
config>router>bgp
```

```
config>router>bgp>group
```

```
config>router>bgp>group>neighbor
```

### Description

This command enables selective download for BGP-LU IPv4 routes.

When this command is configured for a BGP session, received label-IPv4 routes are marked as invalid if they are not required for any eligible service. A label-IPv4 route is considered to be required if one of the following applies:

- it matches the far-end address of a manually configured or auto-created SDP in a Layer 2 VLL or VPLS service and the SDP is configured to use BGP tunnels as transport
- it matches the IPv4 BGP next-hop address of a BGP-EVPN route of an EVPN-VPLS or EVPN-VPWS service
- it matches the far-end address of an explicitly configured SDP in a VPRN service

- it matches the IPv4 BGP next hop of a VPN-IPv4 route and this VPN-IP route is either imported into a VPRN service or readvertised by the router acting as a next-hop-self route reflector
- it matches the IPv4 address in the IPv4-mapped IPv6 address of a VPN-IPv6 route and this VPN-IP route is either imported into a VPRN service or readvertised by the router acting as a next-hop-self route-reflector

The **no** form of this command issued at the **config>router>bgp** level disables selective download for BGP-LU IPv4 routes.

The **no** form of the command used at the group level reverts to the value defined at the global level.

The **no** form of the command used at the neighbor level reverts to the value defined at the group level.

## Default

no selective-label-ipv4-install

## shutdown

## Syntax

[no] shutdown

## Context

config>router>bgp

config>router>bgp>group

config>router>bgp>group>neighbor

## Description

This command administratively disables an entity. When disabled, an entity does not change, reset, or remove any configuration settings or statistics.

The operational state of the entity is disabled as well as the operational state of any entities contained within. Many objects must be shut down before they may be deleted.

The **no** form of this command administratively enables an entity.

Unlike other commands and parameters where the default state is not indicated in the configuration file, the **shutdown** and **no shutdown** states are always indicated in system-generated configuration files.

Default administrative states for services and service entities are described below in Special Cases.

The **no** form of the command places an entity in an administratively enabled state.

## Special cases

### BGP global

the BGP protocol is created in the **no shutdown** state

### BGP group

BGP groups are created in the **no shutdown** state

### BGP neighbor

BGP neighbors/peers are created in the **no shutdown** state

## ttl-security

### Syntax

**ttl-security** *min-ttl-value*

**no ttl-security**

### Context

config>router>bgp>group

config>router>bgp>group>neighbor

### Description

This command configures TTL security parameters for incoming packets. When the feature is enabled, BGP accepts incoming IP packets from a peer only if the TTL value in the packet is greater than or equal to the minimum TTL value configured for that peer.

The **no** form of the command disables TTL security.

### Default

no ttl-security

### Parameters

*min-ttl-value*

the minimum TTL value for an incoming packet

**Values** 1 to 255

**Default** 1

## vpn-apply-export

### Syntax

**[no] vpn-apply-export**

### Context

config>router>bgp

config>router>bgp>group

config>router>bgp>group>neighbor

### Description

This command causes the base instance BGP export route policies to be applied to VPN-IPv4 routes.

The **no** form of the command disables the application of the base instance BGP export route policies to VPN-IPv4 routes.

**Default**

no vpn-apply-export

**vpn-apply-import****Syntax**

[no] vpn-apply-import

**Context**

config>router>bgp

config>router>bgp>group

config>router>bgp>group>neighbor

**Description**

This command causes the base instance BGP import route policies to be applied to VPN-IPv4 routes.

The **no** form of the command disables the application of the base instance BGP import route policies to VPN-IPv4 routes.

**Default**

no vpn-apply-import

### 6.13.2.1.2 Other BGP-related commands

**aggregate****Syntax**

**aggregate** *ip-prefix/ip-prefix-length* [summary-only]

**no aggregate** *ip-prefix/ip-prefix-length*

**Context**

config>router

**Description**

This command creates an aggregate route.

Use this command to group a number of routes with common prefixes into a single entry in the routing table. This reduces the number of routes that need to be advertised by this router and reduces the number of routes in the routing tables of downstream routers.

Both the original components and the aggregated route (source protocol aggregate) are offered to the Routing Table Manager (RTM). Subsequent policies can be configured to assign protocol-specific characteristics, such as the OSPF tag, to aggregate routes.

Multiple entries with the same prefix but a different mask can be configured; routes are aggregated to the longest mask. If one aggregate is configured as 10.0/16 and another as 10.0.0/24, then route 10.0.128/17 would be aggregated into 10.0/16 and route 10.0.0.128/25 would be aggregated into 10.0.0/24. If multiple entries are made with the same prefix and the same mask, the previous entry is overwritten.

The **no** form of the command removes the aggregate.

## Default

no aggregate

## Parameters

*ip-prefix/ip-prefix-length*

the destination IPv4 or IPv6 address of the aggregate route

### **summary-only**

suppresses advertisement of more specific component routes for the aggregate. To remove the **summary-only** option, enter the same aggregate command without the **summary-only** parameter.

## autonomous-system

### Syntax

**autonomous-system** *as-number*

**no autonomous-system**

### Context

config>router

### Description

This command configures the autonomous system (AS) number for the router. A router can only belong to one AS. An AS number is a globally unique number within an AS. This number is used to exchange exterior routing information with neighboring ASs and as an identifier of the AS itself.

If the AS number is changed on a router with an active BGP instance, the new AS number is not used until the BGP instance is restarted either by administratively disabling/enabling (**shutdown/no shutdown**) the BGP instance or rebooting the system with the new configuration.

### Default

no autonomous-system

### Parameters

*as-number*

the autonomous system number expressed as a decimal integer

**Values** 1 to 4294967295

## router-id

### Syntax

**router-id** *ip-address*

**[no] router-id**

### Context

config>router

### Description

This command configures the router ID for the router instance.

The router ID is used by both OSPF and BGP routing protocols in this instance of the routing table manager. IS-IS uses the router ID value as its system ID.

When configuring a new router ID, protocols are not automatically restarted with the new router ID. The next time a protocol is initialized, the new router ID is used. This can result in an interim period of time when different protocols use different router IDs.

To force the new router ID to be used, issue the **shutdown** and **no shutdown** commands for each protocol that uses the router ID, or restart the entire router.

The **no** form of the command reverts to the default value.

### Default

The system uses the system interface address (which is also the loopback address). If a system interface address is not configured, use the last 32 bits of the chassis MAC address.

### Parameters

*ip-address*

32-bit router ID, expressed in dotted-decimal notation or as a decimal value

## 6.13.2.2 Show commands



**Note:** The following command outputs are examples only; actual displays may differ depending on supported functionality and user configuration.

## router

### Syntax

**router** [*router-instance*]

**router service-name** *service-name*

## Context

show

## Description

The command displays router instance information.

## Parameters

*router-instance*

specifies either the router name or service ID

**Values** *router-name*: Base, management  
*service-id*: 1 to 2147483647

**Default** Base

*service-name*

specifies the service name, 64 characters maximum

bgp

## Syntax

bgp

## Context

show>router

## Description

This command enables the context to display BGP-related information.

auth-keychain

## Syntax

auth-keychain [*keychain*]

## Context

show>router>bgp

## Description

This command displays BGP sessions using a particular authentication keychain.

## Parameters

*keychain*

specifies an existing keychain name

## Output

The following output is an example of BGP sessions using an authentication keychain, and [Table 87: BGP auth-keychain field descriptions](#) describes the fields.

### Output example

```
*A:ALU-48# show router bgp auth-keychain
=====
Sessions using key chains
=====
Peer address          Group          Keychain name
-----
10.20.1.3             1             eta_keychain1
-----
No. of Peers: 1
=====
*A:ALU-48#
```

Table 87: BGP auth-keychain field descriptions

Label	Description
Peer address	The IP address of the peer
Group	The BGP group name
Keychain name	Indicates the authentication keychain associated with the session, if applicable

## damping

### Syntax

```
damping [ip-prefix[/ip-prefix-length]] [damp-type] [detail] [ipv4]
damping [ip-prefix[/ip-prefix-length]] [damp-type] [detail] ipv6
damping [ip-prefix[/ip-prefix-length]] [damp-type] [detail] label-ipv4
damping [ip-prefix[/ip-prefix-length]] [damp-type] [detail] label-ipv6
damping [ip-prefix[/ip-prefix-length]] [damp-type] [detail] vpn-ipv4
damping [ip-prefix[/ip-prefix-length]] [damp-type] [detail] vpn-ipv6
damping [ip-prefix[/ip-prefix-length]] [damp-type] [detail] mvpn-ipv4
```

### Context

```
show>router>bgp
```

### Description

This command displays BGP routes that have been dampened due to route flapping. This command can be entered with or without a route parameter. If no parameters are included, all dampened routes are listed.



If the keyword **detail** is included, more detailed information is displayed.

If a *damp-type* is specified, only those types of dampened routes (decayed, history, or suppressed) are displayed. Routes that have a state of **decayed** have gained penalties for flapping but have not yet reached the suppression limit. Routes that have a state of **history** have had a route flap and have been withdrawn. Routes that have a state of **suppressed** have reached the suppression limit and are not considered in BGP path selection.

## Parameters

*ip-prefix/ip-prefix-length*

displays damping information for the specified IP address

*damp-type*

displays damping information for routes with the specified damp type

**Values**    decayed, history, suppressed

**detail**

displays detailed information

**ipv4**

displays dampened routes for the IPv4 address family

**ipv6**

displays dampened routes for the IPv6 address family

**label-ipv4**

displays dampened routes for the labeled IPv4 address family

**label-ipv6**

displays dampened routes for the labeled IPv6 address family

**vpn-ipv4**

displays dampened routes for the VPN-IPv4 address family

**vpn-ipv6**

displays dampened routes for the VPN-IPv6 address family

**mvpn-ipv4**

displays dampened routes for the MVPN-IPv4 address family

## Output

The following output is an example of BGP damping information, and [Table 88: BGP damping field descriptions](#) describes the fields.

### Output example

```
*A: ALU-12>show>router>bgp# damping
=====
BGP Router ID:10.0.0.14      AS:65206      Local AS:65206
=====
Legend -
Status codes  : u - used, s - suppressed, h - history, d - decayed, * - valid
Origin codes  : i - IGP, e - EGP, ? - incomplete, > - best, b - backup
=====
BGP Damped Routes
```

```

=====
Flag Network          From          Reuse          AS-Path
-----
ud*i 10.149.7.0/24      10.0.28.1     00h00m00s     60203 65001 19855 3356
                               1239 22406
si 10.155.6.0/23      10.0.28.1     00h43m41s     60203 65001 19855 3356
                               2914 7459
si 10.155.8.0/22      10.0.28.1     00h38m31s     60203 65001 19855 3356
                               2914 7459
si 10.155.12.0/22     10.0.28.1     00h35m41s     60203 65001 19855 3356
                               2914 7459
si 10.155.22.0/23     10.0.28.1     00h35m41s     60203 65001 19855 3356
                               2914 7459
si 10.155.24.0/22     10.0.28.1     00h35m41s     60203 65001 19855 3356
                               2914 7459
si 10.155.28.0/22     10.0.28.1     00h34m31s     60203 65001 19855 3356
                               2914 7459
si 10.155.40.0/21     10.0.28.1     00h28m24s     60203 65001 19855 3356
                               7911 7459
si 10.155.48.0/20     10.0.28.1     00h28m24s     60203 65001 19855 3356
                               7911 7459
ud*i 10.8.140.0/24     10.0.28.1     00h00m00s     60203 65001 19855 3356
                               4637 17447
ud*i 10.8.141.0/24     10.0.28.1     00h00m00s     60203 65001 19855 3356
                               4637 17447
ud*i 10.9.0.0/18       10.0.28.1     00h00m00s     60203 65001 19855 3356
                               3561 9658 6163
. . .
ud*i 10.213.184.0/23  10.0.28.1     00h00m00s     60203 65001 19855 3356
                               6774 6774 9154
-----
*A:7705_ALU-2>show>router>bgp#

```

```

*A:7705_ALU-2>show>router>bgp# damping detail
=====
BGP Router ID : 10.0.0.0      AS : 65206      Local AS : 65206
=====
Legend -
Status codes : u - used, s - suppressed, h - history, d - decayed, * -
valid
Origin codes : i - IGP, e - EGP, ? - incomplete, - best
=====
BGP Damped Routes
=====
Network : 10.149.7.0/24
-----
Network      : 10.149.7.0/24      Peer      : 10.0.28.1
NextHop      : 10.0.28.1         Reuse time : 00h00m00s
Peer AS      : 60203             Peer Router-Id : 10.10.10.203
Local Pref   : none
Age          : 00h22m09s         Last update  : 02d00h58m
FOM Present  : 738              FOM Last upd. : 2039
Number of Flaps : 2             Flags       : ud*i
Path         : 60203 65001 19855 3356 1239 22406
Applied Policy : default-damping-profile
-----
Network : 10.142.48.0/20
-----
Network      : 10.142.48.0/20    Peer      : 10.0.28.1
NextHop      : 10.0.28.1         Reuse time : 00h00m00s
Peer AS      : 60203             Peer Router-Id : 10.10.10.203
Local Pref   : none

```

```

Age           : 00h00m38s           Last update    : 02d01h20m
FOM Present   : 2011                FOM Last upd. : 2023
Number of Flaps : 2                  Flags          : ud*i
Path          : 60203 65001 19855 3356 3561 5551 1889
Applied Policy : default-damping-profile
-----
Network : 10.200.128.0/19
-----
Network       : 10.200.128.0/19     Peer           : 10.0.28.1
NextHop       : 10.0.28.1          Reuse time    : 00h00m00s
Peer AS       : 60203              Peer Router-Id : 10.10.10.203
Local Pref    : none
Age           : 00h00m38s           Last update    : 02d01h20m
FOM Present   : 2011                FOM Last upd. : 2023
Number of Flaps : 2                  Flags          : ud*i
Path          : 60203 65001 19855 1299 702 1889
Applied Policy : default-damping-profile
-----
Network : 10.203.192.0/18
-----
Network       : 10.203.192.0/18     Peer           : 10.0.28.1
NextHop       : 10.0.28.1          Reuse time    : 00h00m00s
Peer AS       : 60203              Peer Router-Id : 10.10.10.203
Local Pref    : none
Age           : 00h00m07s           Last update    : 02d01h20m
FOM Present   : 1018                FOM Last upd. : 1024
Number of Flaps : 1                  Flags          : ud*i
Path          : 60203 65001 19855 1299 702 1889
Applied Policy : default-damping-profile
-----
*A:7705_ALU-2>show>router>bgp#
    
```

```

*A:7705_ALU-2>show>rouetr>bgp# damping 10.203.192.0/18 detail
=====
BGP Router ID : 10.0.0.14          AS : 65206    Local AS : 65206
=====
Legend -
Status codes : u - used, s - suppressed, h - history, d - decayed, * - valid
Origin codes  : i - IGP, e - EGP, ? - incomplete, - best
=====
BGP Damped Routes 10.203.192.0/18
=====
Network : 10.203.192.0/18
-----
Network       : 10.203.192.0/18     Peer           : 10.0.28.1
NextHop       : 10.0.28.1          Reuse time    : 00h00m00s
Peer AS       : 60203              Peer Router-Id : 10.10.10.203
Local Pref    : none
Age           : 00h00m42s           Last update    : 02d01h20m
FOM Present   : 2003                FOM Last upd. : 2025
Number of Flaps : 2                  Flags          : ud*i
Path          : 60203 65001 19855 3356 702 1889
Applied Policy : default-damping-profile
-----
Paths : 1
=====
*A:7705_ALU-2>show>router>bgp#
    
```

```

*A:7705_ALU-2>show>router>bgp# damping suppressed detail
=====
BGP Router ID : 10.0.0.14          AS : 65206    Local AS : 65206
=====
    
```

```

Legend -
Status codes : u - used, s - suppressed, h - history, d - decayed, * - valid
Origin codes : i - IGP, e - EGP, ? - incomplete, - best
=====
BGP Damped Routes (Suppressed)
=====
Network : 10.142.48.0/20
-----
Network      : 10.142.48.0/20      Peer      : 10.0.28.1
NextHop      : 10.0.28.1          Reuse time : 00h29m22s
Peer AS      : 60203              Peer Router-Id : 10.10.10.203
Local Pref   : none
Age          : 00h01m28s          Last update  : 02d01h20m
FOM Present  : 2936              FOM Last upd. : 3001
Number of Flaps : 3              Flags       : si
Path         : 60203 65001 19855 3356 702 1889
Applied Policy : default-damping-profile
-----
Network : 10.200.128.0/19
-----
Network      : 10.200.128.0/19    Peer      : 10.0.28.1
NextHop      : 10.0.28.1          Reuse time : 00h29m22s
Peer AS      : 60203              Peer Router-Id : 10.10.10.203
Local Pref   : none
Age          : 00h01m28s          Last update  : 02d01h20m
FOM Present  : 2936              FOM Last upd. : 3001
Number of Flaps : 3              Flags       : si
Path         : 60203 65001 19855 3356 702 1889
Applied Policy : default-damping-profile
-----
Network : 10.203.240.0/20
-----
Network      : 10.203.240.0/20    Peer      : 10.0.28.1
NextHop      : 10.0.28.1          Reuse time : 00h29m22s
Peer AS      : 60203              Peer Router-Id : 10.10.10.203
Local Pref   : none
Age          : 00h01m28s          Last update  : 02d01h20m
FOM Present  : 2936              FOM Last upd. : 3001
Number of Flaps : 3              Flags       : si
Path         : 60203 65001 19855 3356 702 1889
Applied Policy : default-damping-profile
-----
Network : 10.206.0.0/17
-----
Network      : 10.206.0.0/17      Peer      : 10.0.28.1
NextHop      : 10.0.28.1          Reuse time : 00h29m22s
Peer AS      : 60203              Peer Router-Id : 10.10.10.203
Local Pref   : none
Age          : 00h01m28s          Last update  : 02d01h20m
FOM Present  : 2936              FOM Last upd. : 3001
Number of Flaps : 3              Flags       : si
Path         : 60203 65001 19855 3356 702 1889
Applied Policy : default-damping-profile
-----
*A:7705_ALU-2>show>router>bgp#
    
```

Table 88: BGP damping field descriptions

Label	Description
BGP Router ID	The local BGP router ID

Label	Description
AS	The configured autonomous system number
Local AS	The configured or inherited local AS for the specified peer group; if not configured, it is the same value as the AS
Network	The IP prefix and mask length for the route
Flag/Flags	Legend: Status codes: u-used, s-suppressed, h-history, d-decayed, *-valid (if an * is not present, the status is invalid) Origin codes: i-IGP, e-EGP, ?-incomplete, >-best
From	The originator ID path attribute value
Reuse/Reuse time	The time when a suppressed route can be used again
AS-Path	The BGP AS path for the route
Peer	The router ID of the advertising router
NextHop	The BGP next hop for the route
Peer AS	The autonomous system number of the advertising router
Peer Router-Id	The router ID of the advertising router
Local Pref	The BGP local preference path attribute for the route
Age	The time elapsed since the service was enabled
Last update	The time that BGP was last updated
FOM Present	The current Figure of Merit (FOM) value
FOM Last upd.	The last updated FOM value
Number of Flaps	The number of flaps in the neighbor connection
Reuse time	The time when the route can be reused
Path	The BGP AS path for the route
Applied Policy	The applied route policy name

## group

### Syntax

**group** [*name*] [*detail*]

## Context

```
show>router>bgp
```

## Description

This command displays group information for a BGP peer group. This command can be entered with or without parameters.

When this command is entered without a group name, information for all peer groups displays.

When the command is issued with a specific group name, information for that specific peer group displays.

The "State" field displays the BGP group's operational state. Valid states are:

- Up – BGP global process is configured and running
- Down – BGP global process is administratively shut down and not running
- Disabled – BGP global process is operationally disabled. The process must be restarted by the operator.

## Parameters

*name*

displays information for the specified BGP group

**detail**

displays detailed information

## Output

The following output is an example of BGP group information, and [Table 89: BGP group field descriptions](#) describes the fields.

### Output example

```
*A:7705_ALU-2>show>router>bgp# group
=====
BGP Group
=====
-----
Group           : bgp_group
-----
Group Type      : No Type           State           : Up
Peer AS        : n/a                Local AS        : 1
Local Address   : n/a                Loop Detect     : Ignore
Import Policy   : None Specified / Inherited
Export Policy   : None Specified / Inherited
Hold Time      : 90                  Keep Alive      : 30
Min Hold Time   : 10
Cluster Id      : None                Client Reflect  : Enabled
NLRI           : Unicast           Preference      : 170
TTL Security    : Enabled           Min TTL Value   : 10
Graceful Restart : Enabled           Stale Routes Time: 360
Auth key chain  : n/a
Bfd Enabled     : Disabled
Creation Origin : manual

Split Horizon   : Disabled

List of Static Peers
- 10.44.44.44 :
```

List of Dynamic Peers

- 10.100.1.3  
- 3ffe::a14:103

Total Peers : 3 Established : 2

Peer Groups : 1

\*A:7705\_ALU-2>show>router>bgp# group detail

BGP Group (detail)

```

Group          : bgp_group
-----
Group Type     : No Type           State          : Up
Peer AS        : n/a              Local AS       : 1
Local Address  : n/a              Loop Detect    : Ignore
Connect Retry  : 120              Authentication : None
Local Pref     : 100              MED Out       : 0
Multihop       : 0 (Default)      AS Override    : Disabled
Min Route Advt. : 30              Min AS Originate : 15
Prefix_Limit   : No Limit
Passive        : Disabled
Next Hop Self  : Disabled          Aggregator ID 0 : Disabled
Remove Private : Disabled          Damping         : Enabled
Import Policy  : None Specified / Inherited
Export Policy  : None Specified / Inherited
Hold Time      : 90              Keep Alive     : 30
Min Hold Time  : 10
Cluster Id     : None            Client Reflect  : Enabled
NLRI           : Unicast         Preference      : 170
TTL Security   : Enabled         Min TTL Value   : 10
Graceful Restart : Enabled       Stale Routes Time: 360
Auth key chain : n/a
Bfd Enabled    : Disabled
Creation Origin : manual
Split Horizon  : Disabled
    
```

List of Static Peers

- 10.44.44.44 :

List of Dynamic Peers

- 10.100.1.3  
- 3ffe::a14:103

Total Peers : 3 Established : 2

Prefix Limits Per Address Family

Family	Limit	Idle Timeout	Threshold	Log Only	Post Import
--------	-------	--------------	-----------	----------	-------------

No prefix-limit entries configured

Peer Groups : 1

\*A:7705\_ALU-2>show>router>bgp#

Table 89: BGP group field descriptions

Label	Description
Group	The BGP group name
Group Type	No Type: peer type not configured External: peer type configured as external BGP peers Internal: peer type configured as internal BGP peers
State	Disabled: the BGP peer group has been operationally disabled Down: the BGP peer group is operationally inactive Up: the BGP peer group is operationally active
Peer AS	The configured or inherited peer AS for the specified peer group
Local AS	The configured or inherited local AS for the specified peer group
Local Address	The configured or inherited local address for originating peering for the specified peer group
Loop Detect	The configured or inherited loop detect setting for the specified peer group
Connect Retry	The configured or inherited connect retry timer value
Authentication	None: no authentication is configured MD5: MD5 authentication is configured
Local Pref	The configured or inherited local preference value
MED Out	The configured or inherited MED value that is assigned to advertised routes
Multihop	The maximum number of router hops a BGP connection can traverse
AS Override	The setting of the AS override
Min Route Advt.	The minimum amount of time that must pass between route updates for the same IP prefix
Min AS Originate	The minimum amount of time that must pass between updates for a route originated by the local router
Prefix_Limit	No Limit: no route limit assigned to the BGP peer group



Label	Description
	1 to 4294967295: the maximum number of routes BGP can learn from a peer
Passive	Disabled: BGP attempts to establish a BGP connection with a neighbor in the specified peer group Enabled: BGP will not actively attempt to establish a BGP connection with a neighbor in the specified peer group
Next Hop Self	Disabled: BGP is not configured to send only its own IP address as the BGP next hop in route updates to neighbors in the peer group Enabled: BGP sends only its own IP address as the BGP next hop in route updates to neighbors in the specified peer group
Aggregator ID 0	Disabled: BGP is not configured to set the aggregator ID to 0.0.0.0 in all originated route aggregates sent to the neighbor in the peer group Enabled: BGP is configured to set the aggregator ID to 0.0.0.0 in all originated route aggregates sent to the neighbor in the peer group
Remove Private	Disabled: BGP will not remove all private AS numbers from the AS path attribute in updates sent to the neighbor in the peer group Enabled: BGP removes all private AS numbers from the AS path attribute in updates sent to the neighbor in the peer group
Damping	Disabled: the peer group is configured not to dampen route flaps Enabled: the peer group is configured to dampen route flaps
Import Policy	The configured import policies for the peer group
Export Policy	The configured export policies for the peer group
Hold Time	The configured hold-time setting
Keep Alive	The configured keepalive setting
Min Hold Time	The configured minimum hold-time setting
Cluster Id	The configured route reflector cluster ID None: No cluster ID has been configured
Client Reflect	Disabled: the BGP route reflector will not reflect routes to this neighbor

Label	Description
	Enabled: the BGP route reflector is configured to reflect routes to this neighbor
NLRI	The type of network layer reachability information that the specified peer group can accept Unicast: IPv4 unicast routing information can be carried
Preference	The configured route preference value for the peer group
TTL Security	Enabled: TTL security is enabled Disabled: TTL security is disabled
Min TTL Value	The minimum TTL value configured for the peer
Graceful Restart	The state of graceful restart
Stale Routes Time	The length of time that stale routes are kept in the route table
Auth key chain	The value for the authentication key chain
Bfd Enabled	Enabled: BFD is enabled Disabled: BFD is disabled
Creation Origin	The creation method of the peer group
Split Horizon	The configured split-horizon setting
List of Static Peers	The list of BGP static peers configured under the peer group
List of Dynamic Peers	The list of BGP dynamic peers learned under the peer group
Total Peers	The total number of peers configured or learned under the peer group
Established	The total number of peers that are in an established state
<b>Prefix Limits Per Address Family</b>	
Family	The IP family
Limit	The maximum number of routes BGP can learn from the address family. "No Limit" means that a limit has not been assigned.
Idle Timeout	The duration, in minutes, before automatically re-establishing a session if it was taken down when the prefix limit was reached
Threshold Log Only	Indicates that a warning message is sent at the specified threshold percentage and also when the prefix limit is reached. The BGP session is not taken down.

Label	Description
Post Import	Indicates that the prefix limit is applied only to the routes that are accepted by import policies
Peer Groups	The number of peer groups

## inter-as-label

### Syntax

**inter-as-label**

### Context

show>router>bgp

### Description

This command displays a summary of BGP inter-autonomous system (inter-AS) service label information pertaining to a next-hop resolution when [enable-rr-vpn-forwarding](#) is enabled.

### Output

The following output is an example of inter-AS service label information, and [Table 90: Inter-AS service label field descriptions](#) describes the fields.

### Output example

```
*A:7705_ALU-2>show>router>bgp# inter-as-labels
=====
BGP Inter-AS labels
=====
NextHop                Received      Advertised    Label
Label                  Label         Label         Origin
-----
10.20.1.1              131069       131057        Internal
10.20.1.1              131070       131055        Internal
10.20.1.1              131071       131056        Internal
10.20.1.2              131068       131050        Internal
10.20.1.2              131070       131053        Internal
10.20.1.6              131066       131049        Internal
10.20.1.6              131067       131052        Internal
10.20.1.6              131070       131051        Internal
-----
Total Labels allocated: 9
=====
```

Table 90: Inter-AS service label field descriptions

Label	Description
NextHop	The BGP next hop ID

Label	Description
Received Label	The service label ID that is received by the Multiprotocol Border Gateway Protocol (MP-BGP)
Advertised Label	The service label ID that is advertised by the MP-BGP
Label Origin	The origin of the received label (either external or internal)
Total Labels allocated	The total number of service labels that are allocated as a result of the next-hop resolution

## neighbor

### Syntax

```

neighbor [ip-address [detail]]
neighbor [as-number [detail]]
neighbor ip-address [family [type mvpn-type]] filter1 [brief]
neighbor ip-address [family] filter2
neighbor as-number [family] filter2
neighbor ip-address orf [filter3]
neighbor ip-address graceful-restart
neighbor [dynamic]

```

### Context

```
show>router>bgp
```

### Description

This command displays BGP neighbor information. This command can be entered with or without any parameters.

When this command is issued without any parameters, information for all BGP peers displays.

When the command is issued with a specific IP address or ASN, information for that specific peer or peers with the same AS displays.



**Note:** This information is not available when using SNMP.

### Parameters

*ip-address*

the specified IP address for which to display information

**detail**

displays detailed information

**as-number**

the specified AS number for which to display information

**Values** 1 to 4294967295

**family**

displays only those BGP peers that have the specified address family enabled

**Values** ipv4 | vpn-ipv4 | ipv6 | vpn-ipv6 | mvpn-ipv4 | route-target | evpn | label-ipv4 | label-ipv6 | bgp-ls

**type**

displays information for the MVPN type

**mvpn-type**

the specified MVPN type for which to display information

**Values** intra-ad | inter-ad | spmsi-ad | leaf-ad | source-ad | shared-join | source-join

**filter1**

displays information for the specified IP address

**Values** received-routes – displays the number of routes received from this peer  
advertised-routes – displays the number of routes advertised by this peer

**filter2**

displays information for the specified AS number

**Values** history – displays statistics for dampened routes  
suppressed – displays the number of paths from this peer that have been suppressed by damping



**Note:** When either received-routes or advertised-routes is specified, the routes that are received from or sent to the specified peer are listed. When either history or suppressed is specified, the routes that are learned from those peers that either have a history or are suppressed are listed.

**brief**

displays information in a brief format. This parameter is only supported with received-routes and advertised-routes.

**orf**

displays outbound route filtering for the BGP instance. ORF (Outbound Route Filtering) is used to inform a neighbor of targets (using target-list) that it is willing to receive. This mechanism helps lessen the update exchanges between neighbors and saves CPU cycles to process routes that could have been received from the neighbor only to be dropped/ignored.

**filter3**

displays path information for the specified IP address

**Values** send – displays the number of paths sent to this peer  
 receive – displays the number of paths received from this peer

**graceful-restart**

displays neighbors configured for graceful restart

**dynamic**

displays information for dynamic BGP neighbors

**Output**

The following outputs are examples of BGP neighbor information:

- BGP neighbor (standard, detailed, and dynamic) ([Output example - BGP neighbor \(standard, detailed, and dynamic\)](#), [Table 91: BGP neighbor \(standard, detailed, and dynamic\) field descriptions](#) )
- BGP neighbor (advertised and received) ([Output example - BGP neighbor \(advertised-routes and received-routes\)](#), [Table 92: BGP neighbor \(advertised-routes and received-routes\) field descriptions](#))
- BGP neighbor (graceful restart) ([Output example - BGP neighbor \(graceful restart\)](#), [Table 93: BGP neighbor \(graceful restart\) field descriptions](#))

**Output example - BGP neighbor (standard, detailed, and dynamic)**

```
*A:7705_ALU-2>show>router>bgp# neighbor
=====
BGP Neighbor
=====
-----
Peer   : 10.10.10.12
Group  : ibgp_group
-----
Peer AS      : 65000          Peer Port      : 49550
Peer Address : 10.10.10.12   Local Port     : 179
Local AS     : 65000          Local Address  : 10.10.10.1
Peer Type    : Internal     Dynamic Peer   : No
State       : Established   Last State     : Established
Last Event   : recvKeepAlive
Last Error   : Cease
Local Family : IPv4 VPN-IPv4
Remote Family : IPv4 VPN-IPv4
Hold Time    : 90           Keep Alive     : 30
Min Hold Time : 10
Active Hold Time : 90       Active Keep Alive : 30
Cluster Id   : None
Preference   : 170        Num of Flaps   : 0
Recd. Paths  : 19
IPv4 Recd. Prefixes : 600      IPv4 Active Prefixes : 563
IPv4 Suppressed Pfxs : 0        VPN-IPv4 Suppr. Pfxs : 0
VPN-IPv4 Recd. Pfxs : 8656     VPN-IPv4 Active Pfxs : 8656
IPv6 Recd. Prefixes : 0        IPv6 Active Prefixes : 0
VPN-IPv6 Recd. Pfxs : 0        VPN-IPv6 Active Pfxs : 0
VPN-IPv6 Suppr. Pfxs : 0

Backup IPv4 Pfxs : 0          Backup IPv6 Pfxs : 0

Backup Vpn IPv4 Pfxs : 0      Backup Vpn IPv6 Pfxs : 0
Input Queue       : 0        Output Queue     : 0
i/p Messages     : 1141     o/p Messages     : 1041
i/p Octets       : 449029   o/p Octets      : 163814
```

```

i/p Updates      : 151          o/p Updates      : 50
TTL Security     : Enabled       Min TTL Value    : 10
Graceful Restart : Disabled     Stale Routes Time : n/a
Advertise Inactive : Disabled   Peer Tracking    : Disabled
Advertise Label  : None
Auth key chain   : n/a
Disable Cap Nego : Disabled     Bfd Enabled     : Disabled
    
```

```

sel-lbl-ipv4-install : Disabled
Local Capability      : RouteRefresh MP-BGP
Remote Capability     : RouteRefresh MP-BGP
Local AddPath Capabi* : Disabled
Remote AddPath Capab* : Send - None
                    : Receive - None
Import Policy         : None Specified / Inherited
Export Policy         : stmt1
    
```

-----  
Neighbors : 1  
=====

\*A:7705\_ALU-2>show>router>bgp#

\*A:7705\_ALU-2>show>router>bgp# neighbor 10.10.10.12 detail

=====

BGP Neighbor

-----  
Peer : 10.10.10.12  
Group : iBGP

```

-----
Peer AS           : 65000          Peer Port        : 49550
Peer Address      : 10.10.10.12
Local AS          : 65000          Local Port       : 179
Local Address     : 10.10.10.1
Peer Type         : Internal       Dynamic Peer     : No
State             : Established    Last State      : Established
Last Event       : recvKeepAlive
Last Error       : Cease
Local Family      : IPv4 VPN-IPv4
Remote Family     : IPv4 VPN-IPv4
Connect Retry    : 120
Min Route Advt.  : 30
Multihop         : 0 (Default)
Damping          : Disabled
MED Out          : No MED Out
Next Hop Self    : Disabled
Remove Private   : Disabled
Peer Identifier   : 10.10.10.12
Fsm Est. Time    : 22h42m46s
Prefix Limit     : No Limit
Hold Time        : 90
Min Hold Time    : 10
Active Hold Time : 90
Cluster Id       : None
Preference       : 170
Recd. Paths      : 19
IPv4 Recd. Prefixes : 600
VPN-IPv4 Recd. Pfxs : 8656
IPv6 Recd. Prefixes : 0
VPN-IPv6 Recd. Pfxs : 0
VPN-IPv6 Suppr. Pfxs : 0
Backup IPv4 Pfxs  : 0

Peer Port        : 49550
Local Port       : 179
Dynamic Peer     : No
Last State      : Established
Local Pref.     : 70
Min AS Orig.    : 15
AS Override     : Disabled
Loop Detect     : Ignore
Authentication  : None
AggregatorID Zero : Disabled
Passive         : Disabled
Fsm Est. Trans  : 1
InUpd Elap. Time : 22h54m31s
Pref Limit Idle Time* : forever
Keep Alive      : 30
Active Keep Alive : 30
Client Reflect  : Disabled
Num of Flaps    : 0
IPv4 Active Prefixes : 563
VPN-IPv4 Suppr. Pfxs : 0
VPN-IPv4 Active Pfxs : 8656
IPv6 Suppressed Pfxs : 0
IPv6 Active Prefixes : 0
VPN-IPv6 Active Pfxs : 0
Backup IPv6 Pfxs   : 0
    
```

```

Backup Vpn IPv4 Pfxs : 0          Backup Vpn IPv6 Pfxs : 0
Input Queue          : 0          Output Queue          : 0
i/p Messages        : 2881       o/p Messages         : 2777
i/p Octets           : 482089    o/p Octets           : 196798
i/p Updates         : 151        o/p Updates          : 50
TTL Security        : Enabled     Min TTL Value        : 10
Graceful Restart    : Disabled    Stale Routes Time    : n/a
Advertise Inactive  : Disabled    Peer Tracking        : Disabled
Advertise Label     : None
Auth key chain      : n/a
Bfd Enabled         : Enabled
Disable Cap Nego    : Disabled     Bfd Enabled          : Disabled
Local Capability    : RtRefresh MPBGP 4byte ASN
Remote Capability   :
Local AddPath Capabi*: Disabled
Remote AddPath Capab*: Send - None
                   : Receive - None
Import Policy       : None Specified / Inherited
Export Policy       : stmt1
    
```

-----  
Neighbors : 1  
=====

\*A:7705\_ALU-2>show>router>bgp#

\*A:7705\_ALU-2>show>router>bgp# neighbor 10.0.0.11 orf

=====

BGP Neighbor 10.0.0.11 ORF

=====

Send List (Automatic)

-----

target:65535:10  
target:65535:20

=====

\*A:7705\_ALU-2>show>router>bgp#

\*A:7705\_ALU-2>show>router>bgp# neighbor 10.0.0.1 orf

=====

BGP Neighbor 10.0.0.1 ORF

=====

Receive List

-----

target:65535:10  
target:65535:20

=====

\*A:7705\_ALU-2>show>router>bgp#

\*A:7705\_ALU-2>show>router>bgp# neighbor dynamic

=====

BGP Neighbor

=====

-----

Peer : 10.100.1.3  
Description : (Not Specified)  
Group : dynamic

-----

Peer AS	: 65000	Peer Port	: 51374
Peer Address	: 10.100.1.3	Local Port	: 179
Local AS	: 65000	Dynamic Peer	: Yes
Local Address	: 10.100.1.2	Last State	: Established
Peer Type	: Internal		
State	: Established		
Last Event	: recvKeepAlive		



```

Last Error          : Cease (Connection Collision Resolution)
Local Family       : IPv4 VPN-IPv4 IPv6 VPN-IPv6
Remote Family     : IPv4 VPN-IPv4 IPv6 VPN-IPv6
Hold Time         : 90          Keep Alive           : 30
Min Hold Time     : 0
Active Hold Time  : 90          Active Keep Alive : 30
Cluster Id        : None
Preference        : 170        Num of Update Flaps : 0
Recd. Paths       : 6
IPv4 Recd. Prefixes : 5          IPv4 Active Prefixes : 0
IPv4 Suppressed Pfxs : 0        VPN-IPv4 Suppr. Pfxs : 0
VPN-IPv4 Recd. Pfxs : 0          VPN-IPv4 Active Pfxs : 0
IPv6 Suppressed Pfxs : 0
IPv6 Recd. Prefixes : 2          IPv6 Active Prefixes : 0
VPN-IPv6 Recd. Pfxs : 0          VPN-IPv6 Active Pfxs : 0
VPN-IPv6 Suppr. Pfxs : 0
MVPN-IPv4 Suppr. Pfxs : 0        MVPN-IPv4 Recd. Pfxs : 0
MVPN-IPv4 Active Pfxs : 0
Flow-IPv4 Suppr. Pfxs : N/A      Flow-IPv4 Recd. Pfxs : N/A
Flow-IPv4 Active Pfxs : N/A      Rte-Tgt Suppr. Pfxs : 0
Rte-Tgt Recd. Pfxs : 0          Rte-Tgt Active Pfxs : 0
Backup IPv4 Pfxs  : 0          Backup IPv6 Pfxs    : 0
Mc Vpn Ipv4 Suppr. P*: N/A
Backup Vpn IPv4 Pfxs : 0        Backup Vpn IPv6 Pfxs : 0
Input Queue       : 0          Output Queue        : 0
i/p Messages     : 11         o/p Messages        : 9
i/p Octets       : 951        o/p Octets          : 445
i/p Updates      : 6          o/p Updates         : 4
Evpn Suppr. Pfxs : 0          Evpn Recd. Pfxs    : 0
Evpn Active Pfxs : 0
MS-PW Suppr. Pfxs : N/A      MS-PW Recd. Pfxs   : N/A
MS-PW Active Pfxs : N/A
TTL Security     : Disabled    Min TTL Value       : n/a
Graceful Restart : Disabled    Stale Routes Time   : n/a
Advertise Inactive : Disabled  Peer Tracking       : Disabled
Auth key chain   : n/a
Disable Cap Nego : N/A        Bfd Enabled         : Disabled
Flowspec Validate : N/A      Default Route Tgt   : Disabled
Aigp Metric      : Disabled    Split Horizon       : Enabled
Local Capability : RtRefresh MPBGP 4byte ASN
Remote Capability : RtRefresh MPBGP 4byte ASN
Local AddPath Capabi*: Disabled
Remote AddPath Capab*: Send - None
                  : Receive - None
Import Policy     : None Specified / Inherited
Export Policy     : expPol
Origin Validation : N/A
EBGP Link Bandwidth : n/a
IPv4 Rej. Pfxs   : 0          IPv6 Rej. Pfxs     : 0
VPN-IPv4 Rej. Pfxs : 0        VPN-IPv6 Rej. Pfxs : 0
Mc IPv4 Rej. Pfxs : 0          Mc IPv6 Rej. Pfxs  : 0
MVPN-IPv4 Rej. Pfxs : 0        MVPN-IPv6 Rej. Pfxs : 0
Flow-IPv4 Rej. Pfxs : 0        Flow-IPv6 Rej. Pfxs : 0
L2-VPN Rej. Pfxs  : 0          MDT-SAFI Rej. Pfxs : 0
Rte-Tgt Rej. Pfxs : 0          MS-PW Rej. Pfxs    : 0
Mc Vpn Ipv4 Rej. Pfxs : 0        Evpn Rej. Pfxs     : 0
Label-v4 Suppr. Pfxs : 0        Label-v4 Recd. Pfxs : 0
Label-v4 Active Pfxs : 0        Label-v4 Rej. Pfxs : 0
Label-v6 Suppr. Pfxs : 0        Label-v6 Recd. Pfxs : 0
Label-v6 Active Pfxs : 0        Label-v6 Rej. Pfxs : 0
Bgp-Ls Suppr. Pfxs : 0          Bgp-Ls Recd. Pfxs  : 0
Bgp-Ls Active Pfxs : 0          Bgp-Ls Rej. Pfxs   : 0
-----
    
```

Table 91: BGP neighbor (standard, detailed, and dynamic) field descriptions

Label	Description
Peer	The IP address of the configured BGP peer
Group	The BGP peer group to which this peer is assigned
Peer AS	The configured or inherited peer AS for the peer group
Peer Address	The configured address for the BGP peer
Peer Port	The TCP port number used on the far-end system
Local AS	The configured or inherited local AS for the peer group
Local Address	The configured or inherited local address for originating peering for the peer group
Local Port	The TCP port number used on the local system
Peer Type	External: peer type configured as external BGP peers
	Internal: peer type configured as internal BGP peers
Dynamic Peer	Yes: the session is dynamic (that is, unconfigured)
	No: the session is statically configured
State	Idle: The BGP peer is not accepting connections. (Shutdown) is also displayed if the peer is administratively disabled.
	Active: BGP is listening for and accepting TCP connections from this peer
	Connect: BGP is attempting to establish a TCP connection with this peer
	Open Sent: BGP has sent an OPEN message to the peer and is waiting for an OPEN message from the peer
	Open Confirm: BGP has received a valid OPEN message from the peer and is awaiting a KEEPALIVE or NOTIFICATION
	Established: BGP has successfully established a peering session and is exchanging routing information
Last State	Idle: The BGP peer is not accepting connections
	Active: BGP is listening for and accepting TCP connections from this peer

Label	Description
	Connect: BGP is attempting to establish a TCP connections with this peer
	Open Sent: BGP has sent an OPEN message to the peer and is waiting for an OPEN message from the peer
	Open Confirm: BGP has received a valid OPEN message from the peer and is awaiting a KEEPALIVE or NOTIFICATION
Last Event	start: BGP has initialized the BGP neighbor
	stop: BGP has disabled the BGP neighbor
	open: BGP transport connection is opened
	close: BGP transport connection is closed
	openFail: BGP transport connection failed to open
	error: BGP transport connection error
	connectRetry: the connect retry timer expired
	holdTime: the hold time timer expired
	keepAlive: the keepalive timer expired
	recvOpen: BGP has received an OPEN message
	revKeepalive: BGP has received a KEEPALIVE message
	recvUpdate: BGP has received an UPDATE message
	recvNotify: BGP has received a NOTIFICATION message
	None: no events have occurred
Last Error	The last BGP error and subcode to occur on the BGP neighbor
Local Family	The configured local family value
Remote Family	The configured remote family value
Connect Retry	The configured or inherited connect retry timer value
Local Pref.	The configured or inherited local preference value
Min Route Advt.	The minimum amount of time that must pass between route updates for the same IP prefix
Min AS Originate	The minimum amount of time that must pass between updates for a route originated by the local router

Label	Description
Multihop	The maximum number of router hops a BGP connection can traverse
Damping	Disabled: the BGP neighbor is configured not to dampen route flaps
	Enabled: the BGP neighbor is configured to dampen route flaps
Loop Detect	Ignore: The BGP neighbor is configured to ignore routes with an AS loop
	Drop: The BGP neighbor is configured to drop the BGP peering if an AS loop is detected
	Off: AS loop detection is disabled for the neighbor
MED Out	The configured or inherited MED value that is assigned to advertised routes
Authentication	None: no authentication is configured
	MD5: MD5 authentication is configured
Next Hop Self	Disabled: BGP is not configured to send only its own IP address as the BGP next hop in route updates to the specified neighbor
	Enabled: BGP will send only its own IP address as the BGP next hop in route updates to the neighbor
AggregatorID Zero	Disabled: the BGP neighbor is not configured to set the aggregator ID to 0.0.0.0 in all originated route aggregates
	Enabled: the BGP neighbor is configured to set the aggregator ID to 0.0.0.0 in all originated route aggregates
Remove Private	Disabled: BGP will not remove all private AS numbers from the AS path attribute in updates sent to the specified neighbor
	Enabled: BGP will remove all private AS numbers from the AS path attribute in updates sent to the specified neighbor
Passive	Disabled: BGP will actively attempt to establish a BGP connection with the specified neighbor
	Enabled: BGP will not actively attempt to establish a BGP connection with the specified neighbor
Peer Identifier	The IP identifier for the peer router

Label	Description
Prefix_Limit	No Limit: no route limit assigned to the BGP peer group
	1 to 4294967295: the maximum number of routes BGP can learn from a peer
Pref Limit Idle Time*	The length of time that the session is held in the idle state after it is taken down as a result of reaching the prefix limit
Hold Time	The configured hold-time setting
Keep Alive	The configured keepalive setting
Min Hold Time	The configured minimum hold-time setting
Active Hold Time	The negotiated hold time, if the BGP neighbor is in an established state
Active Keep Alive	The negotiated keepalive time, if the BGP neighbor is in an established state
Cluster Id	The configured route reflector cluster ID
	None: no cluster ID has been configured
Client Reflect	Disabled: The BGP route reflector is configured not to reflect routes to this neighbor
	Enabled: The BGP route reflector is configured to reflect routes to this neighbor
Preference	The configured route preference value for the peer group
Num of Flaps	The number of route flaps in the neighbor connection
Recd. Paths	The number of unique sets of path attributes received from the BGP neighbor
IPv4 Recd. Prefixes	The number of unique sets of IPv4 path attributes received from the BGP neighbor
IPv4 Active Prefixes	The number of IPv4 routes received from the BGP neighbor and active in the forwarding table
IPv4 Suppressed Pfxs	The number of unique sets of IPv4 path attributes received from the BGP neighbor and suppressed due to route damping
VPN-IPv4 Suppr. Pfxs	The number of unique sets of VPN-IPv4 path attributes received from the BGP neighbor and suppressed due to route damping
VPN-IPv4 Recd. Pfxs	The number of unique sets of VPN-IPv4 path attributes received from the BGP neighbor

Label	Description
VPN-IPv4 Active Pfxs	The number of VPN-IPv4 routes received from the BGP neighbor and active in the forwarding table
IPv6 Suppressed. Pfxs	The number of unique sets of IPv6 path attributes received from the BGP neighbor and suppressed due to route damping
IPv6 Recd. Prefixes	The number of unique sets of IPv6 path attributes received from the BGP neighbor
IPv6 Active Prefixes	The number of IPv6 routes received from the BGP neighbor and active in the forwarding table
VPN-IPv6 Recd. Pfxs	The number of unique sets of VPN-IPv6 path attributes received from the BGP neighbor
VPN-IPv6 Active Pfxs	The number of VPN-IPv6 routes received from the BGP neighbor and active in the forwarding table
VPN-IPv6 Suppr. Pfxs	The number of unique sets of VPN-IPv6 path attributes received from the BGP neighbor and suppressed due to route damping
MVPN-IPv4 Suppr. Pfxs	The number of unique sets of MVPN-IPv4 path attributes received from the BGP neighbor and suppressed due to route damping
MVPN-IPv4 Recd. Pfxs	The number of unique sets of MVPN-IPv4 path attributes received from the BGP neighbor
MVPN-IPv4 Active Pfxs	The number of MVPN-IPv4 routes received from the BGP neighbor and active in the forwarding table
Flow-IPv4 Suppr. Pfxs	N/A
Flow-IPv4 Recd. Pfxs	N/A
Flow-IPv4 Active Pfxs	N/A
Rte-Tgt Suppr. Pfxs	The number of unique sets of route target path attributes received from the BGP neighbor and suppressed due to route damping
Rte-Tgt Recd. Pfxs	The number of unique sets of route target path attributes received from the BGP neighbor
Rte-Tgt Active. Pfxs	The number of route target routes received from the BGP neighbor and active in the forwarding table
Backup IPv4 Pfxs	The number of BGP fast reroute backup path IPv4 prefixes
Backup IPv6 Pfxs	The number of BGP fast reroute backup path IPv6 prefixes

Label	Description
Mc Vpn Ipv4 Suppr. P*	N/A
Backup Vpn IPv4 Pfxs	The number of BGP fast reroute backup path VPN IPv4 prefixes
Backup Vpn IPv6 Pfxs	The number of BGP fast reroute backup path VPN IPv6 prefixes
Input Queue	The number of BGP messages to be processed
Output Queue	The number of BGP messages to be transmitted
i/p Messages	The total number of packets received from the BGP neighbor
o/p Messages	The total number of packets sent to the BGP neighbor
i/p Octets	The total number of octets received from the BGP neighbor
o/p Octets	The total number of octets sent to the BGP neighbor
i/p Updates	The total number of updates received from the BGP neighbor
o/p Updates	The total number of updates sent to the BGP neighbor
Evpn Suppr. Pfxs	The number of unique sets of EVPN-IPv4 path attributes received from the BGP neighbor and suppressed due to route damping
Evpn Recd. Pfxs	The number of unique sets of EVPN-IPv4 path attributes received from the BGP neighbor
Evpn Active Pfxs	The number of EVPN-IPv4 routes received from the BGP neighbor and active in the forwarding table
MS-PW Suppr. Pfxs	N/A
MS-PW Recd. Pfxs	N/A
MS-PW Active Pfxs	N/A
TTL Security	Enabled: TTL security is enabled Disabled: TTL security is disabled
Min TTL Value	The minimum TTL value configured for the peer
Graceful Restart	The state of graceful restart
Stale Routes Time	The length of time that stale routes are kept in the route table
Advertise Inactive	The state of advertising inactive BGP routes to other BGP peers (enabled or disabled)

Label	Description
Peer Tracking	The state of tracking a neighbor IP address in the routing table for a BGP session
Advertise Label	Indicates the enabled address family for supporting RFC 3107 BGP label capability
Auth key chain	The value for the authentication key chain
Disable Cap Nego	N/A
Bfd Enabled	Enabled: BFD is enabled Disabled: BFD is disabled
Flowspec Validate	N/A
Default Route Tgt	Indicates that the default RTC route (zero prefix length) is originated toward the selected peers
Aigp Metric	Indicates whether accumulated IGP (AIGP) path attribute support with one or more BGP peers is enabled or disabled
Split Horizon	Indicates whether split horizon is enabled or disabled, When enabled, split horizon prevents routes from being reflected back to a peer that sends the best route.
sel-ibl-ipv4-install	Indicates whether BGP-LU selective download is enabled or disabled
Local Capability	The capability of the local BGP speaker; for example, route refresh, MP-BGP, ORF
Remote Capability	The capability of the remote BGP peer; for example, route refresh, MP-BGP, ORF
Local AddPath Capabi*	The state of the local BGP add-paths capabilities. The add-paths capability allows the router to send and receive multiple paths per prefix to or from a peer.
Remote AddPath Capab*	The state of the remote BGP add-paths capabilities
Import Policy	The configured import policies for the peer group
Export Policy	The configured export policies for the peer group
Origin Validation	N/A
EBGP Link Bandwidth	N/A
IPv4 Rej. Pfxs	The number of unique sets of IPv4 path attributes received from the BGP neighbor and rejected by the router



Label	Description
IPv6 Rej. Pfxs	The number of unique sets of IPv6 path attributes received from the BGP neighbor and rejected by the router
VPN-IPv4 Rej. Pfxs	The number of unique sets of VPN-IPv4 path attributes received from the BGP neighbor and rejected by the router
VPN-IPv6 Rej. Pfxs	The number of unique sets of VPN-IPv6 path attributes received from the BGP neighbor and rejected by the router
Mc IPv4 Rej. Pfxs	The number of unique sets of MC IPv4 path attributes received from the BGP neighbor and rejected by the router
Mc IPv6 Rej. Pfxs	The number of unique sets of MC IPv6 path attributes received from the BGP neighbor and rejected by the router
MVPN-IPv4 Rej. Pfxs	The number of unique sets of MVPN-IPv4 path attributes received from the BGP neighbor and rejected by the router
MVPN-IPv6 Rej. Pfxs	The number of unique sets of MVPN-IPv6 path attributes received from the BGP neighbor and rejected by the router
Flow-IPv4 Rej. Pfxs	The number of unique sets of Flow-IPv4 path attributes received from the BGP neighbor and rejected by the router
Flow-IPv6 Rej. Pfxs	The number of unique sets of Flow-IPv6 path attributes received from the BGP neighbor and rejected by the router
L2-VPN Rej. Pfxs	The number of unique sets of L2-VPN path attributes received from the BGP neighbor and rejected by the router
MDT-SAFI Rej. Pfxs	The number of unique sets of MDT-SAFI path attributes received from the BGP neighbor and rejected by the router
Rte-Tgt Rej. Pfxs	The number of unique sets of route target path attributes received from the BGP neighbor and rejected by the router
MS-PW Rej. Pfxs	The number of unique sets of MS-PW path attributes received from the BGP neighbor and rejected by the router
Mc Vpn Ipv4 Rej. Pfxs	The number of unique sets of MC VPN IPv4 path attributes received from the BGP neighbor and rejected by the router
Evpn Rej. Pfxs	The number of unique sets of EVPN path attributes received from the BGP neighbor and rejected by the router
Label-v4 Suppr. Pfxs	The number of unique sets of label-IPv4 path attributes received from the BGP neighbor and suppressed due to route damping
Label-v4 Recd. Pfxs	The number of unique sets of label-IPv4 path attributes received from the BGP neighbor

Label	Description
Label-v4 Active Pfxs	The number of label-IPv4 routes received from the BGP neighbor and active in the forwarding table
Label-v4 Rej. Pfxs	The number of unique sets of label-IPv4 path attributes received from the BGP neighbor and rejected by the router
Label-v6 Suppr. Pfxs	The number of unique sets of label-IPv6 path attributes received from the BGP neighbor and suppressed due to route damping
Label-v6 Recd. Pfxs	The number of unique sets of label-IPv6 path attributes received from the BGP neighbor
Label-v6 Active Pfxs	The number of label-IPv6 routes received from the BGP neighbor and active in the forwarding table
Label-v6 Rej. Pfxs	The number of unique sets of label-IPv6 path attributes received from the BGP neighbor and rejected by the router
Bgp-Ls Suppr. Pfxs	The number of unique sets of BGP LS path attributes received from the BGP neighbor and suppressed due to route damping
Bgp-Ls Recd. Pfxs	The number of unique sets of BGP LS path attributes received from the BGP neighbor
Bgp-Ls Active Pfxs	The number of BGP LS routes received from the BGP neighbor and active in the forwarding table
Bgp-Ls Rej. Pfxs	The number of unique sets of BGP LS path attributes received from the BGP neighbor and rejected by the router

**Output example - BGP neighbor (advertised-routes and received-routes)**

```
*A:7705_ALU-2>show>router>bgp# neighbor 10.44.44.44 advertised-routes
=====
BGP Router ID : 10.55.55.55      AS : 1      Local AS : 1
=====
Legend -
Status codes : u - used, s - suppressed, h - history, d - decayed, * - valid
Origin codes : i - IGP, e - EGP, ? - incomplete, > - best
=====
BGP IPv4 Routes
=====
Flag  Network                               LocalPref  MED
      Nexthop                             Path-Id    Label
      As-Path
-----
?    10.0.0.0/24                          100        none
      10.0.0.16
      No As-Path
?    10.0.6.0/24                          100        none
      10.0.0.16
      No As-Path
-----
```

```

Routes : 2
=====
*A:7705_ALU-2>show>router>bgp#

*A:PE1>show>router>bgp# neighbor 10.10.10.12 advertised-routes brief
=====
BGP Router ID : 10.10.10.1      AS : 65000   Local AS : 65000
=====
Legend -
Status codes : u - used, s - suppressed, h - history, d - decayed, * - valid
Origin codes : i - IGP, e - EGP, ? - incomplete, > - best
=====
BGP IPv4 Routes
=====
Flag Network
-----
? 10.10.10.1/32
? 10.10.10.0/24
? 10.10.10.1/24
? 10.10.10.2/24
? 10.10.10.3/24
-----
Routes : 5
=====
*A:7705_ALU-2>show>router>bgp#

```

```

*A:7705_ALU-2>show>router>bgp# neighbor 10.44.44.44 received-routes
=====
BGP Router ID : 10.55.55.55      AS : 1      Local AS : 1
=====
Legend -
Status codes : u - used, s - suppressed, h - history, d - decayed, * - valid
Origin codes : i - IGP, e - EGP, ? - incomplete, > - best
=====
BGP IPv4 Routes
=====
Flag Network                LocalPref  MED
NextHop                    Path-Id    Label
As-Path
-----
? 10.0.0.16/32              100        none
  10.0.0.16
  No As-Path
? 10.0.6.0/24               100        none
  10.0.0.16 -
  No As-Path
? 10.0.8.0/24              100        none
  10.0.0.16
  No As-Path
? 10.0.12.0/24             100        none
  10.0.0.16
  No As-Path
-----
Routes : 4
=====
*A:7705_ALU-2>show>router>bgp#

```

Table 92: BGP neighbor (advertised-routes and received-routes) field descriptions

Label	Description
BGP Router ID	The local BGP router ID
AS	The configured autonomous system number
Local AS	The configured local AS setting. If not configured, then it is the same value as the AS.
Flag/Flags	<p>Legend:</p> <p>Status codes:</p> <ul style="list-style-type: none"> <li>u - used</li> <li>s - suppressed</li> <li>h - history</li> <li>d - decayed</li> <li>* - valid</li> </ul> <p>If an * is not present, then the status is invalid</p> <p>Origin codes:</p> <ul style="list-style-type: none"> <li>i - IGP</li> <li>e - EGP</li> <li>? - incomplete</li> <li>&gt; - best</li> </ul>
Network	The route IP prefix and mask length for the route
Next Hop	The BGP next hop for the route
LocalPref	The BGP local preference path attribute for the route
MED	The BGP Multi-Exit Discriminator (MED) path attribute for the route
Path-Id	The path ID that is received as part of the add-path capability
Label	The BGP label associated with the route
AS-Path	The BGP AS path for the route

**Output example - BGP neighbor (graceful restart)**

```
*A:7705_ALU-2>show>router>bgp# neighbor 10.10.120.44 graceful-restart
=====
BGP Neighbor 10.10.120.44 Graceful Restart
=====
Graceful Restart locally configured for peer      : Enabled
Peer's Graceful Restart feature                  : Enabled
NLRI(s) that peer supports restart for          : IPv4-Unicast IPv4-MPLS IPv4-VPN
```

```

NLRI(s) that peer saved forwarding for      : IPv4-Unicast IPv4-MPLS IPv4-VPN
NLRI(s) that restart is negotiated for     : None
NLRI(s) of received end-of-rib markers    : IPv4-Unicast
NLRI(s) of all end-of-rib markers sent     : IPv4-Unicast
Restart time locally configured for peer   : 120 seconds
Restart time requested by the peer        : 390 seconds
Time stale routes from peer are kept for   : 360 seconds
Graceful restart status on the peer       : Not currently being helped
Number of Restarts                        : 328
Last Restart at                          : 08/20/2006 12:22:06
=====
*A:7705_ALU-2>show>router>bgp#
    
```

Table 93: BGP neighbor (graceful restart) field descriptions

Label	Description
BGP Neighbor	The IP address of the BGP neighbor
Graceful Restart locally configured for peer	The configured state of graceful restart for the local router
Peer's Graceful Restart feature	The configured state of graceful restart for the peer router
NLRI(s) that peer supports restart for	The families supported by the peer router for graceful restart
NLRI(s) that peer saved forwarding for	The families for which the peer router continued to forward packets after graceful restart
NLRI(s) that restart is negotiated for	The families that negotiate restart during graceful restart
NLRI(s) of received end-of-rib markers	The families for which end-of-RIB markers have been received
NLRI(s) of all end-of-rib markers sent	The families for which end-of-RIB markers have been sent
Restart time locally configured for peer	The length of time configured on the local router for the peer router's graceful restart
Restart time requested by the peer	The length of time requested by the peer router for graceful restart
Time stale routes from peer are kept for	The length of time that the local router continues to support stale routes
Graceful restart status on the peer	The status of graceful restart on the peer router
Number of Restarts	The number of restarts since graceful restart is enabled between peers

Label	Description
Last Restart at	The local time of the last graceful restart

## next-hop

### Syntax

**next-hop** [*family* [**service-id** *service-id*]] [*ip-address* [**detail**]]

### Context

show>router>bgp

### Description

This command displays BGP next-hop information.

### Parameters

#### *family*

displays only those BGP values that have the specified address family enabled

**Values** ipv4 | ipv6 | label-ipv4 | label-ipv6 | vpn-ipv4 | vpn-ipv6 | evpn

#### *service-id*

specifies the service ID

**Values** 1 to 2147483647

#### *ip-address*

displays the next hop-information for the specified IP address

#### **detail**

displays the more detailed version of the output

### Output

The following output is an example of BGP next-hop information, and [Table 94: BGP next-hop field descriptions](#) describes the fields.

#### Output example

```
A:7705_ALU-2>show>router>bgp# next-hop
=====
BGP Router ID : 10.10.10.1      AS : 65000   Local AS : 65000
=====
BGP Next Hop
=====
Next Hop                Pref      Owner
  Resolving Prefix      Metric
  Resolved Next Hop     Ref. Count
-----
10.10.10.12            7        ISIS
```

```

10.20.1.1/32          10
10.10.2.1            592
10.10.10.12         7  ISIS
10.20.1.2/32       10
10.10.3.2          592
10.20.1.4          7  ISIS
10.20.0.0/32      20
10.10.11.4        8
-----
Next Hops : 3
=====
A:7705_ALU-2>show>router>bgp#

```

```

A:7705_ALU-2>show>router>bgp# next-hop 10.0.0.1
=====
BGP Router ID : 10.10.10.1      AS : 65000   Local AS : 65000
=====
BGP Next Hop
=====
Next Hop          Pref Owner
Resolving Prefix  Metric
Resolved Next Hop Ref. Count
-----
10.0.0.1         15  ISIS
10.0.0.0/24     20
10.88.1.2       8
10.0.0.1        15  ISIS
10.0.0.0/24     20
10.88.2.2       8
-----
Next Hops : 1
=====
A:7705_ALU-2>show>router>bgp#

```

```

A:7705_ALU-2>show>router>bgp# next-hop 10.0.0.1 detail
=====
BGP Router ID : 10.10.10.1      AS : 65000   Local AS : 65000
=====
BGP Next Hop
=====
Next Hop: 10.0.0.1
-----
Resolving Prefix : 10.0.0.0/24
Preference       : 15           Metric       : 20
Reference Count  : 8           Owner        : ISIS
Resolved Next Hop: 10.88.1.2
Egress Label    : N/A
Resolved Next Hop: 10.88.2.2
Egress Label    : N/A
Resolved Next Hop: 10.88.3.2
Egress Label    : N/A
-----
Next Hops : 1
=====
A:7705_ALU-2>show>router>bgp#

```

The following output displays an example of when the next hop is unresolved by a next-hop-resolution policy.

```

A:7705_ALU-2>show router bgp next-hop
=====
BGP Router ID:10.20.1.3      AS:100      Local AS:100
=====
BGP Next Hop
=====
Next Hop      Resolving Prefix      Pref      Owner
      Resolved Next Hop      FibProg      Metric
-----
10.20.1.2      10.20.1.2/32      10      OSPF
      10.10.3.2      Y      1000
10.20.1.4      10.20.1.4/32      10      OSPF
      10.10.11.4      Y      1
10.20.1.5      Unresolved      -      -
      --      -
-----
Next Hops : 3
=====
    
```

Table 94: BGP next-hop field descriptions

Label	Description
BGP Router ID	The local BGP router ID
AS	The configured autonomous system number
Local AS	The configured local AS setting. If not configured, then the value is the same as the AS.
Next Hop	The next-hop address
Resolving Prefix	The prefix of the best next hop
Pref: Preference	The BGP preference attribute for the routes
FibProg	Indicates whether a resolved BGP next hop is programmed in the FIB
Metric	The metric derived from the IGP for a particular next hop
Reference Count	The number of routes using the resolving prefix
Owner	The routing protocol used to derive the best next hop
Resolved Next Hop	The IP address of the next hop
Egress Label	The VPN label used for VPN-IPv4 data
Next Hops	The number of next hops



## paths

### Syntax

paths

### Context

show>router>bgp

### Description

This command displays a summary of BGP path attributes.

### Output

The following output is an example of BGP path information, and [Table 95: BGP path field descriptions](#) describes the fields.

### Output example

```
*A:7705_ALU-2>show>router>bgp# paths
=====
BGP Router ID : 10.55.55.55 AS : 65000   Local AS : 65000
=====
BGP Paths
=====
Path: No As-Path
-----
Next Hop      : 10.44.10.12
Origin       : Incomplete           Segments      : 0
MED          : None                 Local Preference : 4294967295
Refs         : 1080                 ASes         : 0
Flags        : IBGP-learned
-----
Path: No As-Path
-----
Next Hop      : 10.88.1.2
Origin       : IGP                  Segments      : 0
MED          : 10                   Local Preference : None
Refs         : 4                    ASes         : 0
Flags        : Imported
-----
Path: No As-Path
-----
Next Hop      : 10.44.10.21
Origin       : IGP                  Segments      : 0
MED          : None                 Local Preference : 100
Refs         : 1082                 ASes         : 0
Flags        : IBGP-learned
Cluster      : 10.10.10.12
Originator Id : 10.10.10.21
-----
Paths : 3
=====
*A:7705_ALU-2>show>router>bgp#
```

Table 95: BGP path field descriptions

Label	Description
BGP Router ID	The local BGP router ID
AS	The configured autonomous system number
Local AS	The configured local AS setting. If not configured, then the value is the same as the AS.
Path	The AS path attribute
Next Hop	The advertised BGP next hop
Origin	EGP: the NLRI is learned by an EGP protocol
	IGP: the NLRI is interior to the originating AS
	Incomplete: NLRI was learned another way
Segments	The number of segments in the AS path attribute
MED	The Multi-Exit Discriminator value
Local Preference	The local preference value. This value is used if the BGP route arrives from a BGP peer without the Local Pref attribute set. It is overridden by any value set via a route policy.
Refs	The number of routes using a specified set of path attributes
ASes	The number of autonomous system numbers in the AS path attribute
Flags	IBGP-learned: path attributes learned by an IBGP peering
Community	The BGP community attribute list
Cluster List	The route reflector cluster list
Originator ID	The originator ID path attribute value

## routes

### Syntax

**routes** [*ip-prefix/mask* | *ip-address*]

**routes aspath-regex** *reg-exp* {**detail** | **longer**}

**routes aspath-regex** *reg-exp*

**routes aspath-regex** *reg-exp* **hunt**

**routes bgp-ls [hunt] [node | link | ipv4-prefix [ipv4-prefix/mask-len]]**  
**routes brief**  
**routes community comm-id {detail |longer}**  
**routes community comm-id**  
**routes community comm-id hunt**  
**routes detail**  
**routes hunt [brief]**  
**routes ipv4 [aspath-regex reg-exp] [community comm-id] [brief] [all]**  
**routes ipv4 [aspath-regex reg-exp] hunt [community comm-id] [brief] [all]**  
**routes ipv4 [detail |longer] [aspath-regex reg-exp] [community comm-id] [all]**  
**routes ipv6 [aspath-regex reg-exp] [community comm-id] [brief] [all]**  
**routes ipv6 [aspath-regex reg-exp] hunt [community comm-id] [brief] [all]**  
**routes ipv6 [detail |longer] [aspath-regex reg-exp] [community comm-id] [all]**  
**routes label-ipv4 [aspath-regex reg-exp] [community comm-id] [brief] [all]**  
**routes label-ipv4 [aspath-regex reg-exp] hunt [community comm-id] [brief] [all]**  
**routes label-ipv4 [detail | longer] [aspath-regex reg-exp] [community comm-id] [all]**  
**routes label-ipv6 [aspath-regex reg-exp] [community comm-id] [brief] [all]**  
**routes label-ipv6 [aspath-regex reg-exp] hunt [community comm-id] [brief] [all]**  
**routes label-ipv6 [detail | longer] [aspath-regex reg-exp] [community comm-id] [all]**  
**routes longer**  
**routes mvpn-ipv4 [aspath-regex reg-exp] [community comm-id] [rd rd] [brief] [type mvpn-type]**  
**[originator-ip ip-address] [source-ip ipv4 address | ipv6 address] [group-ip ipv4 address | ipv6 address]**  
**[source-as as-number]**  
**routes mvpn-ipv4 [aspath-regex reg-exp] hunt [community comm-id] [rd rd] [brief] [type mvpn-type]**  
**[originator-ip ip-address] [source-ip ipv4 address | ipv6 address] [group-ip ipv4 address | ipv6 address]**  
**[source-as as-number]**  
**routes mvpn-ipv4 [detail |longer] [aspath-regex reg-exp] [community comm-id] [rd rd] [type mvpn-type]**  
**[originator-ip ip-address] [source-ip ipv4 address | ipv6 address] [group-ip ipv4 address | ipv6 address]**  
**[source-as as-number]**  
**routes route-target [source-as as-number] [brief] [aspath-regex reg-exp] [community comm-id]**  
**routes route-target [rtc-prefix rtc-prefix] [hunt] [brief] [aspath-regex reg-exp] [community comm-id]**  
**routes route-target rtc-prefix rtc-prefix [aspath-regex reg-exp] [community comm-id]**  
**routes route-target [rtc-prefix rtc-prefix] [detail | longer] [aspath-regex reg-exp] [community comm-id]**  
**routes vpn-ipv4 [aspath-regex reg-exp] [community comm-id] [rd rd] [brief]**  
**routes vpn-ipv4 [aspath-regex reg-exp] hunt [community comm-id] [rd rd] [brief]**  
**routes vpn-ipv4 [detail |longer] [aspath-regex reg-exp] [community comm-id] [rd rd]**  
**routes vpn-ipv6 [aspath-regex reg-exp] [community comm-id] [rd rd] [brief]**  
**routes vpn-ipv6 [aspath-regex reg-exp] hunt [community comm-id] [rd rd] [brief]**

**routes vpn-ipv6** [**detail** | **longer**] [**aspath-regex** *reg-exp*] [**community** *comm-id*] [**rd** *rd*]

## Context

show>router>bgp

## Description

This command displays BGP route information.

When this command is issued without any parameters, the entire BGP routing table displays.

When this command is issued with an IP prefix/mask or IP address, the best match for the parameter displays.



**Note:** To apply a family filter to the route output of the command, the family name must be specified before all other filtering parameters except for the IP prefix/mask or IP address, which, if present, must be placed before the family name in the command.

## Parameters

*ip-prefix/mask* | *ip-address*

displays parameters that match the specified IPv4 prefix and mask length or IPv6 address (256 characters maximum)

**aspath-regex** *reg-exp*

displays all routes with an AS path matching the specified regular expression (80 characters maximum)

**bgp-ls**

displays BGP Link State routes

**ipv4-prefix**

displays BGP LS NLRI of type IPv4 Prefix

**link**

displays BGP Link State NLRI of type Link

**node**

displays BGP Link State NLRI of type Node

**brief**

provides a summarized display of the set of peers to which a BGP route is advertised; this option is only supported when no IP prefix/mask or IP address is specified

**community**

displays all routes with the specified BGP community; community matching is based only on RIB-In communities, not RIB-Out communities

*comm-id*

specifies community IDs, in the format *as-number1:comm-val1* | *ext-comm* | *well-known-comm*

### Values

*as-number1* 0 to 65535

*comm-val1* 0 to 65535

<i>ext-comm</i>	<p><i>type</i>: {<i>ip-address:comm-val1</i>   <i>as-number1:comm-val2</i> [<i>as-number2:comm-val1</i>   <i>as-number1:val-in-mbps</i>]} <i>ext:xyy:ovstate</i></p> <p>where</p> <p><i>type</i>: <b>target</b>   <b>origin</b>   <b>bandwidth</b> (keywords)</p> <p><i>ip-address</i>:</p> <p><i>ipv4-address</i>: a.b.c.d</p> <p><i>ipv6-address</i>: x:x:x:x:x:x[x[-<i>interface</i>] x:x:x:x:x:d.d.d.d[-<i>interface</i>] <i>interface</i> - 32 chars max, mandatory for link local addresses x: [0 to FFFF]H d: [0 to 255]D</p>
<i>ext:xyy:ovstate</i>	<p><i>xx</i>: 43</p> <p><i>yy</i>: 0</p> <p><i>ovstate</i>: 0, 1, 2 (0 for valid, 1 for not-found, 2 for invalid)</p>
<i>well-known-comm</i>	<b>null</b>   <b>no-export</b>   <b>no-export-subconfed</b>   <b>no-advertise</b> (keywords)

**group-ip** *ipv4 address* | *ipv6 address*

displays the group IPv4 or IPv6 address

**originator-ip** *ip-address*

displays the originating IPv4 or IPv6 address

**source-ip** *ipv4 address* | *ipv6 address*

displays the source IPv4 or IPv6 address

**detail**

displays a more detailed version of the output

**source-as** *as-number*

displays the source AS number

**hunt**

displays entries for the specified route in the RIB-In, RIB-Out, and RTM

**ipv4**

displays only those BGP peers that have the IPv4 family enabled

**ipv6**

displays only those BGP peers that have the IPv6 family enabled

**label-ipv4**

displays only those BGP peers for the labeled IPv4 unicast address family

**label-ipv6**

displays only those BGP peers for the labeled IPv6 unicast address family

**longer**

displays the specified route and subsets of the route

**mvpn-ipv4**

displays the BGP peers that are MVPN-IPv4 capable

*mvpn-type*

the specified MVPN type for which to display information

**Values** intra-ad | inter-ad | spmsi-ad | leaf-ad | source-ad | shared-join | source-join

**route-target**

displays a summary of route target constrained routes for this BGP peer

**rtc-prefix** *rtc-prefix*

displays route target constraint prefix information, in the format *source-as:{ip-addr:comm-val | 2byte-asnumber:ext-comm-val | 4byte-asnumber:comm-val}/prefix-length*

**Values** *ip-addr:*  
*ipv4-address:* a.b.c.d  
*ipv6-address:* x:x:x:x:x:x:x[-*interface*] x:x:x:x:x:d.d.d.d[-*interface*]  
*interface* - 32 chars max, mandatory for link local addresses x: [0 to FFFF]H d: [0 to 255]D  
*comm-val:* 0 to 65535  
*2byte-asnumber:* 0 to 65535  
*ext-comm-val:* 0 to 4294967295  
*4byte-asnumber:* 0 to 4294967295  
*prefix-length:* 0 to 96

**rd** *rd*

displays the route distinguisher value, in the format *ip-addr:comm-val | 2byte-asnumber:ext-comm-val | 4-byte-asnumber:comm-val*

**Values** *ip-addr:*  
*ipv4-address:* a.b.c.d  
*ipv6-address:* x:x:x:x:x:x:x[-*interface*] x:x:x:x:x:d.d.d.d[-*interface*]  
*interface* - 32 chars max, mandatory for link local addresses x: [0 to FFFF]H d: [0 to 255]D  
*comm-val:* 0 to 65535  
*2byte-asnumber:* 0 to 65535  
*ext-comm-val:* 0 to 4294967295  
*4byte-asnumber:* 0 to 4294967295

**vpn-ipv4**

displays the BGP VPN IPv4 routes

**vpn-ipv6**

displays the BGP VPN IPv6 routes

**originator-ip ip-address**

filters BGP MVPN routes by the originating router IP address that is found in the intra-AD (auto-discovery) MVPN routes

**source-ip ip-address**

filters BGP MVPN routes by the source IP address that is found in the source-join, source-AD, or S-PMSI-AD MVPN routes

**group-ip ip-address**

filters BGP MVPN routes by the multicast group IP address that is found in the source-join, source-AD, or S-PMSI-AD MVPN routes

**source-as as-number**

filters BGP MVPN routes by source-AS (autonomous system) extended community attribute

**Output**

The following output is an example of BGP route information, and [Table 96: BGP route field descriptions](#) describes the fields.

**Output example**

```
*A: Sar18 Dut-B# show router bgp routes 10.10.10.5
=====
BGP Router ID:10.20.1.3      AS:100      Local AS:100
=====
Legend -
Status codes  : u - used, s - suppressed, h - history, d - decayed, * - valid
                l - leaked, x - stale, > - best, b - backup, p - purge
Origin codes  : i - IGP, e - EGP, ? - incomplete
=====
BGP IPv4 Routes
=====
Flag  Network                LocalPref  MED
      Nexthop (Router)      Path-Id    Label
      As-Path
-----
u*>? 10.10.10.0/24            None       None
      10.20.1.4             None       -
      200 300
-----
Routes : 1
=====
*A: Sar18 Dut-B##

*A: Sar18 Dut-B# show>router>bgp# routes vpn-ipv4 10.10.10.6/32 rd 10.20.1.4:1 hunt
=====
BGP Router ID:10.20.1.3      AS:None     Local AS:100
=====
Legend -
Status codes  : u - used, s - suppressed, h - history, d - decayed, * - valid
                l - leaked, x - stale, > - best, b - backup, p - purge
Origin codes  : i - IGP, e - EGP, ? - incomplete, > - best, b - backup
=====
BGP VPN-IPv4 Routes
```

```

=====
-----
RIB In Entries
-----
Network      : 10.10.10.6/32
Nextthop    : 10.20.1.4
Route Dist.  : 10.20.1.4:1          VPN Label      : 131070
Path Id      : None
From        : 10.20.1.4
Res. Nextthop : n/a
Local Pref.  : 100                  Interface Name : int_to_D
Aggregator AS : None                Aggregator     : None
Atomic Aggr. : Not Atomic           MED            : None
AIGP Metric  : None
Connector    : None
Community    : target:100:100
Cluster      : No Cluster Members
Originator Id : None                Peer Router Id  : 10.20.1.4
Fwd Class    : None                Priority        : None
Flags        : Used Valid Best Incomplete
Route Source : Internal
AS-Path      : 106
VPRN Imported : 1
-----
RIB Out Entries
-----
Routes : 1
=====
*A: Sar18 Dut-B#

*A: Sar18 Dut-B# show>router>bgp# routes 3FFE::606:609/128 vpn-ipv6 hunt
=====
BGP Router ID:10.20.1.3      AS:None      Local AS:100
=====
Legend -
Status codes : u - used, s - suppressed, h - history, d - decayed, * - valid
               l - leaked, x - stale, > - best, b - backup, p - purge
Origin codes  : i - IGP, e - EGP, ? - incomplete, > - best, b - backup
=====
BGP VPN-IPv6 Routes
=====
-----
RIB In Entries
-----
Network      : 3FFE::606:609/128
Nextthop    : ::FFFF:A14:104
Route Dist.  : 10.20.1.4:1          VPN Label      : 131070
Path Id      : None
From        : 10.20.1.4
Res. Nextthop : n/a
Local Pref.  : 100                  Interface Name : int_to_D
Aggregator AS : None                Aggregator     : None
Atomic Aggr. : Not Atomic           MED            : None
AIGP Metric  : None
Connector    : None
Community    : target:100:100
Cluster      : No Cluster Members
Originator Id : None                Peer Router Id  : 10.20.1.4
Fwd Class    : None                Priority        : None
Flags        : Used Valid Best Incomplete
Route Source : Internal
AS-Path      : 106
    
```



```

VPRN Imported : 1
-----
RIB Out Entries
-----
Routes : 1
=====
*A: Sar18 Dut-B#

*A: Sar18 Dut-B# show>router>bgp# routes vpn-ipv6 3FFE::606:607 128 rd 10.20.1.4:1
hunt
=====
BGP Router ID:10.20.1.3      AS:None      Local AS:100
=====
Legend -
Status codes : u - used, s - suppressed, h - history, d - decayed, * - valid
               l - leaked, x - stale, > - best, b - backup, p - purge
Origin codes  : i - IGP, e - EGP, ? - incomplete, > - best, b - backup
=====
BGP VPN-IPv6 Routes
=====
RIB In Entries
-----
Network       : 3FFE::606:607/128
Nextthop      : ::FFFF:A14:104
Route Dist.   : 10.20.1.4:1      VPN Label    : 131070
Path Id       : None
From          : 10.20.1.4
Res. Nextthop : n/a
Local Pref.   : 100
Aggregator AS : None             Interface Name : int_to_D
Atomic Aggr.  : Not Atomic      Aggregator    : None
AIGP Metric   : None           MED           : None
Connector     : None
Community     : target:100:100
Cluster       : No Cluster Members
Originator Id : None           Peer Router Id : 10.20.1.4
Fwd Class     : None           Priority       : None
Flags         : Used Valid Best Incomplete
Route Source  : Internal
AS-Path       : 106
VPRN Imported : 1
-----
RIB Out Entries
-----
Routes : 1
=====
*A: Sar18 Dut-B#

*A: Sar18 Dut-B# show>router>bgp# routes vpn-ipv6 3FFE::606:607/128 rd 10.20.1.4:2
hunt
=====
BGP Router ID:10.20.1.3      AS:None      Local AS:100
=====
Legend -
Status codes : u - used, s - suppressed, h - history, d - decayed, * - valid
               l - leaked, x - stale, > - best, b - backup, p - purge
Origin codes  : i - IGP, e - EGP, ? - incomplete, > - best, b - backup
=====
BGP VPN-IPv6 Routes

```

```

=====
No Matching Entries Found
=====
*A:Sar18 Dut-B#

*A:Sar18 Dut-B# show router bgp routes hunt 10.10.10.1/32
=====
BGP Router ID:10.20.1.3      AS:5000      Local AS:5000
=====
Legend -
Status codes : u - used, s - suppressed, h - history, d - decayed, * - valid
               l - leaked, x - stale, > - best, b - backup, p - purge
Origin codes  : i - IGP, e - EGP, ? - incomplete, > - best
=====
BGP IPv4 Routes
=====
RIB In Entries
-----
Network       : 10.10.10.1/32
Nexthop       : 10.20.1.1
From          : 10.20.1.1
Res. Nexthop  : 10.20.1.1 (RSVP LSP: 1)
Local Pref.   : 100
Aggregator AS : None
Atomic Aggr.  : Not Atomic
Community     : No Community Members
Cluster       : No Cluster Members
Originator Id : None
Peer Router Id : 10.20.1.1
Flags         : Used Valid Best Incomplete
AS-Path       : No As-Path
-----
RIB Out Entries
-----
Routes : 1
=====
*A:Sar18 Dut-B#

*A:Sar18 Dut-B# show router bgp routes family ipv4
=====
BGP Router ID : 10.10.10.103      AS : 200      Local AS : 200
=====
Legend -
Status codes : u - used, s - suppressed, h - history, d - decayed, * - valid
               l - leaked, x - stale, > - best, b - backup, p - purge
Origin codes  : i - IGP, e - EGP, ? - incomplete, > - best
=====
BGP Routes
=====
Flag Network                Nexthop      LocalPref MED
  VPN Label                As-Path
-----
No Matching Entries Found
=====
*A:Sar18 Dut-B#

*A:Sar18 Dut-B# show router bgp routes 10.10.10.0/24 detail
=====
BGP Router ID : 10.128.0.161 AS : 65535 Local AS : 65535
=====

```

```

Legend -
Status codes : u - used, s - suppressed, h - history, d - decayed, * - valid
               l - leaked, x - stale, > - best, b - backup, p - purge
Origin codes  : i - IGP, e - EGP, ? - incomplete, > - best
=====
BGP Routes
=====
Original Attributes
Network       : 10.10.10.0/24  Nexthop       : 10.20.1.20
Route Dist.   : 10070:100     VPN Label     : 152784
From          : 10.20.1.20    Res. Nexthop  : 10.130.0.2
Local Pref.   : 100
Aggregator AS : none         Aggregator    : none
Atomic Aggr.  : Not Atomic   MED           : none
Community     : target:10070:1
Cluster       : No Cluster Members
Originator Id : None         Peer Router Id : 10.20.1.20
Flags         : Used Valid Best IGP LABEL-UNICAST-NO-SVC
AS-Path       : 10070 {14730}
Modified Attributes

Network :10.10.10.0/24 Nexthop :10.20.1.20
Route Dist.: 10001:100 VPN Label :152560
From :10.20.1.20 Res. Nexthop :10.130.0.2
Local Pref.:100
Aggregator AS: none Aggregator:none
Atomic Aggr.:Not Atomic MED :none
Community :target:10001:1
Cluster :No Cluster Members
Originator Id:None Peer Router Id:10.20.1.20
Flags :Used Valid Best IGP
AS-Path :No As-Path
-----
*A: Sar18 Dut-B#

*A: Sar18 Dut-B# show router bgp routes 10.10.10.0/24 hunt
=====
BGP Router ID : 10.20.1.1  AS : 100Local AS : 100
=====
Legend -
Status codes : u - used, s - suppressed, h - history, d - decayed, * - valid
               l - leaked, x - stale, > - best, b - backup, p - purge
Origin codes  : i - IGP, e - EGP, ? - incomplete, > - best
=====
BGP Routes
=====
RIB In Entries
-----
Network       : 10.10.10.0/24
Nexthop       : 10.20.1.2
Route Dist.   : 10.20.1.2:1VPN Label: 131070
From          : 10.20.1.2
Res. Nexthop  : 10.10.1.2
Local Pref.   : 100Interface Name: to-sr7
Aggregator AS : noneAggregator: none
Atomic Aggr.  : Not AtomicMED: none
Community     : target:10.20.1.2:1
Cluster       : No Cluster Members
Originator Id : NonePeer Router Id: 10.20.1.2
Flags         : Used Valid Best IGP
AS-Path       : No As-Path
VPRN Imported : 1 2 10 12
-----

```

```

RIB Out Entries
-----
Routes : 1
=====
*A: Sar18 Dut-B#

*A: Sar18 Dut-B# show router bgp routes mvpn-ipv4
=====
BGP Router ID:10.20.1.3      AS:200      Local AS:200
=====
Legend -
Status codes : u - used, s - suppressed, h - history, d - decayed, * - valid
               l - leaked, x - stale, > - best, b - backup, p - purge
Origin codes  : i - IGP, e - EGP, ? - incomplete, > - best
=====
BGP MVPN-IPv4 Routes
=====
Flag  RouteType      OriginatorIP      LocalPref  MED      VPNLabel
      RD
      Nexthop
      As-Path
-----
u*>i  Intra-Ad        10.20.1.4        100        0
      1:1
      10.20.1.4
      No As-Path
u*>i  Source-Ad        -                100        0
      1:1
      10.20.1.4      10.100.1.2
      No As-Path      10.0.0.0
u*>i  Source-Join      -                100        0
      1:1
      10.20.1.4      200
      No As-Path      10.100.1.2
      10.0.0.0
-----
Routes : 3
=====
*A: Sar18 Dut-B#

*A: Sar18 Dut-B# show router bgp routes mvpn-ipv4 brief
=====
BGP Router ID:10.20.1.3      AS:200      Local AS:200
=====
Legend -
Status codes : u - used, s - suppressed, h - history, d - decayed, * - valid
               l - leaked, x - stale, > - best, b - backup, p - purge
Origin codes  : i - IGP, e - EGP, ? - incomplete, > - best
=====
BGP MVPN-IPv4 Routes
=====
Flag  RouteType      OriginatorIP      SourceIP
      RD
      SourceAS
      GroupIP
-----
u*>i  Intra-Ad        10.20.1.4        -
      1:1
u*>i  Source-Ad        -                10.100.1.2
      1:1
      10.0.0.0
u* >i  Source-Join      -                10.100.1.2
      1:1
      200
      10.0.0.0
-----
Routes : 3
=====

```

```
*A: Sar18 Dut-B#
```

```
*A: Sar18 Dut-B# show router bgp routes mvpn-ipv4 type source-join source-as 200
source-ip 10.100.1.2 group-ip 10.0.0.0 detail
```

```
=====
BGP Router ID:10.20.1.3      AS:200      Local AS:200
=====
```

```
Legend -
```

```
Status codes : u - used, s - suppressed, h - history, d - decayed, * - valid
               l - leaked, x - stale, > - best, b - backup, p - purge
```

```
Origin codes : i - IGP, e - EGP, ? - incomplete, > - best
```

```
=====
BGP MVPN-IPv4 Routes
=====
```

```
Route Type      : Source-Join
Route Dist.     : 1:1
Source AS       : 200
Source IP       : 10.100.1.2
Group IP        : 10.0.0.0
Nextthop        : 10.20.1.4
From            : 10.20.1.4
Res. Nextthop   : 10.0.0.0
Local Pref.     : 100
Aggregator AS   : None
Atomic Aggr.    : Not Atomic
Community       : target:10.20.1.3:2
Cluster         : No Cluster Members
Originator Id   : None
Flags           : Used Valid Best IGP
AS-Path         : No As-Path
Peer Router Id  : 10.20.1.4
Interface Name  : NotAvailable
Aggregator      : None
MED             : 0
```

```
-----
Routes : 1
=====
```

```
*A: Sar18 Dut-B#
```

```
*A: Sar18 Dut-B# show router bgp routes ipv4 detail
```

```
=====
BGP Router ID:10.1.1.1      AS:100      Local AS:100
=====
```

```
Legend -
```

```
Status codes : u - used, s - suppressed, h - history, d - decayed, * - valid
               l - leaked, x - stale, > - best, b - backup, p - purge
```

```
Origin codes : i - IGP, e - EGP, ? - incomplete, > - best, b - backup
```

```
=====
BGP IPv4 Routes
=====
```

```
-----
Original Attributes
```

```
Network         : 10.1.1.1/32
Nextthop        : 192.168.1.1
Path Id         : None
From            : 192.168.1.1
Res. Nextthop   : 192.168.1.1
Local Pref.     : n/a
Aggregator AS   : None
Atomic Aggr.    : Not Atomic
AIGP Metric     : 100
Community       : None
Cluster         : No Cluster Members
Originator Id   : None
Peer Router Id  : 2.2.2.2
Interface Name  : net
Aggregator      : None
MED             : 5000
```

```
Fwd Class      : None          Priority       : None
Flags          : Used Valid Best Incomplete
Route Source   : External
AS-Path        : 200 400 500
```

Modified Attributes

```
Network        : 10.1.1.1/32
Nexthop        : 192.168.1.1
Path Id        : None
From           : 192.168.1.1
Res. Nexthop   : 192.168.1.1
Local Pref.    : None
Aggregator AS  : None          Interface Name : net
Atomic Aggr.   : Not Atomic    Aggregator     : None
AIGP Metric    : 110           MED            : 5000
Community      : None
Cluster        : No Cluster Members
Originator Id  : None          Peer Router Id : 2.2.2.2
Fwd Class      : None          Priority       : None
Flags          : Used Valid Best Incomplete
Route Source   : External
AS-Path        : 200 400 500
```

-----  
Routes : 1

=====

```
*A: Sar18 Dut-B#
```

```
*A: Sar18 Dut-B# show router bgp routes 10.1.1.1/32 hunt
```

=====

```
BGP Router ID: 1.1.1.1          AS: 100          Local AS: 100
```

Legend -

```
Status codes : u - used, s - suppressed, h - history, d - decayed, * - valid
               l - leaked, x - stale, > - best, b - backup, p - purge
Origin codes  : i - IGP, e - EGP, ? - incomplete, > - best, b - backup
```

=====

BGP IPv4 Routes

-----

RIB In Entries

```
Network        : 10.1.1.1/32
Nexthop        : 192.168.1.1
Path Id        : None
From           : 192.168.1.1
Res. Nexthop   : 192.168.1.1
Local Pref.    : None
Aggregator AS  : None          Interface Name : net
Atomic Aggr.   : Not Atomic    Aggregator     : None
AIGP Metric    : 110           MED            : 5000
Community      : None
Cluster        : No Cluster Members
Originator Id  : None          Peer Router Id : 2.2.2.2
Fwd Class      : None          Priority       : None
Flags          : Used Valid Best Incomplete
Route Source   : External
AS-Path        : 200 400 500
```

-----

RIB Out Entries

-----

```
Network        : 10.1.1.1/32
```

```

Nexthop      : 10.1.1.1
Path Id      : None
To           : 10.3.3.3
Res. Nexthop : n/a
Local Pref.  : 100
Aggregator AS : None
Atomic Aggr. : Not Atomic
AIGP Metric  : 150
Community    : None
Cluster      : No Cluster Members
Originator Id : None
Origin       : Incomplete
AS-Path      : 200 400 500
Interface Name : NotAvailable
Aggregator    : None
MED           : 5000
Peer Router Id : 10.3.3.3
    
```

-----  
Routes : 2  
=====

\*A: Sar18 Dut-B#

\*A: Sar18 Dut-B# show router bgp routes

```

=====
BGP Router ID:10.20.1.1      AS:1      Local AS:1
=====
Legend -
Status codes : u - used, s - suppressed, h - history, d - decayed, * - valid
               l - leaked, x - stale, > - best, b - backup, p - purge
Origin codes  : i - IGP, e - EGP, ? - incomplete, > - best, b - backup
    
```

=====
BGP IPv4 Routes
=====

Flag	Network	LocalPref	MED
	Nexthop	Path-Id	Label
	As-Path		
u*>i	10.0.0.1/32	100	2010
	10.20.1.2	None	131057
	2		
ub*i	10.0.0.1/32	100	2010
	10.20.1.3	None	131067
	2		

-----  
Routes : 2  
=====

\*A: Sar18 Dut-B#

\*A: Sar18# show router bgp routes vpn-ipv4 community target:100.100.100.100:2 hunt

```

=====
BGP Router ID:10.20.1.6      AS:62000      Local AS:62000
=====
Legend -
Status codes : u - used, s - suppressed, h - history, d - decayed, * - valid
               l - leaked, x - stale, > - best, b - backup, p - purge
Origin codes  : i - IGP, e - EGP, ? - incomplete
    
```

=====
BGP VPN-IPv4 Routes
=====

-----  
RIB In Entries
-----

```

Network      : 10.1.1.1/32
Nexthop      : 10.20.1.6
Route Dist.  : 100.100.100.100:2      VPN Label    : 131068
    
```

```

Path Id      : None
From        : 10.20.1.5
Res. Nexthop : n/a
Local Pref. : 100
Aggregator AS : None
Atomic Aggr. : Not Atomic
AIGP Metric  : None
Connector    : None
Community    : target:100.100.100.100:2
Cluster      : 5.5.5.5
Originator Id : 10.20.1.6
Flags        : Invalid IGP
Route Source : Internal
AS-Path      : No As-Path
Route Tag    : 0
Neighbor-AS  : N/A
Add Paths Send : Default
Last Modified : 00h00m06s
VPRN Imported : None
    
```

```

Interface Name : system
Aggregator     : None
MED            : 100
    
```

```
Peer Router Id : 10.20.1.5
```

-----  
RIB Out Entries  
-----

```

Network      : 10.1.1.1/32
Nexthop      : 10.20.1.6
Route Dist.  : 100.100.100.100:2
Path Id      : None
To           : 10.20.1.5
Res. Nexthop : n/a
Local Pref.  : 100
Aggregator AS : None
Atomic Aggr. : Not Atomic
AIGP Metric  : None
Connector    : None
Community    : target:100.100.100.100:2
Cluster      : No Cluster Members
Originator Id : None
Origin       : IGP
AS-Path      : No As-Path
Route Tag    : 0
Neighbor-AS  : N/A
    
```

```
VPN Label      : 131068
```

```

Interface Name : NotAvailable
Aggregator     : None
MED            : None
    
```

```
Peer Router Id : 10.20.1.5
```

-----  
Routes : 2  
=====

\*A: Sarl8#

```
*A: Sarl8# show router bgp routes vpn-ipv6 community target:100.100.100.100:2 hunt
```

```
=====
BGP Router ID:10.20.1.3      AS:61000      Local AS:61000
=====
```

Legend -

```

Status codes : u - used, s - suppressed, h - history, d - decayed, * - valid
               l - leaked, x - stale, > - best, b - backup, p - purge
Origin codes  : i - IGP, e - EGP, ? - incomplete
    
```

=====
BGP VPN-IPv6 Routes
=====

-----  
RIB In Entries  
-----

```

Network      : 3ffe::100:0/109
Nexthop      : ::ffff:10.20.1.1
Route Dist.  : 1:1234
Path Id      : None
    
```

```
VPN Label      : 131067
```



```

From          : 10.20.1.2
Res. Nexthop  : n/a
Local Pref.   : 100
Aggregator AS : None
Atomic Aggr.  : Not Atomic
AIGP Metric   : None
Connector     : None
Community     : 0:0 target:100.100.100.100:2 target:1:123456
               origin:100.100.100.100:2
Cluster       : 2.2.2.2
Originator Id : 10.20.1.1
Peer Router Id : 10.20.1.2
Flags         : Used Valid Best IGP
Route Source  : Internal
AS-Path       : No As-Path
Route Tag     : 0
Neighbor-AS   : N/A
Add Paths Send : Default
Last Modified : 00h03m41s
VPRN Imported : 3 1

Network       : 3ffe::101:100/120
Nexthop       : ::ffff:10.20.1.1
Route Dist.   : 1:1234
Path Id       : None
VPN Label     : 131067
From          : 10.20.1.2
Res. Nexthop  : n/a
Local Pref.   : 100
Aggregator AS : None
Atomic Aggr.  : Not Atomic
AIGP Metric   : None
Connector     : None
Community     : 0:0 target:100.100.100.100:2 target:1:123456
               origin:100.100.100.100:2
Cluster       : 2.2.2.2
Originator Id : 10.20.1.1
Peer Router Id : 10.20.1.2
Flags         : Used Valid Best IGP
Route Source  : Internal
AS-Path       : No As-Path
Route Tag     : 0
Neighbor-AS   : N/A
Add Paths Send : Default
Last Modified : 00h03m41s
VPRN Imported : 3 1

Network       : 3ffe::101:100/123
Nexthop       : ::ffff:10.20.1.1
Route Dist.   : 1:1234
Path Id       : None
VPN Label     : 131067
From          : 10.20.1.2
Res. Nexthop  : n/a
Local Pref.   : 100
Aggregator AS : None
Atomic Aggr.  : Not Atomic
AIGP Metric   : None
Connector     : None
Community     : 0:0 target:100.100.100.100:2 target:1:123456
               origin:100.100.100.100:2
Cluster       : 2.2.2.2
Originator Id : 10.20.1.1
Peer Router Id : 10.20.1.2
Flags         : Used Valid Best IGP
Route Source  : Internal
AS-Path       : No As-Path
Route Tag     : 0
Neighbor-AS   : N/A

```

```

Add Paths Send : Default
Last Modified  : 00h03m41s
VPRN Imported  : 3 1

Network        : 3ffe::300:0/104
NextHop        : ::ffff:10.20.1.1
Route Dist.    : 1:1234                VPN Label      : 131067
Path Id        : None
From           : 10.20.1.2
Res. NextHop   : n/a
Local Pref.    : 100                  Interface Name  : toA
Aggregator AS : None                  Aggregator     : None
Atomic Aggr.   : Not Atomic           MED            : 100
AIGP Metric    : None
Connector      : None
Community      : 0:0 target:100.100.100.100:2 target:1:123456
                origin:123456:2
Cluster        : 2.2.2.2
Originator Id  : 10.20.1.1            Peer Router Id  : 10.20.1.2
Flags          : Used Valid Best IGP
Route Source   : Internal
AS-Path        : No As-Path
Route Tag      : 0
Neighbor-AS    : N/A
Add Paths Send : Default
Last Modified  : 00h03m41s
VPRN Imported  : 3 1

Network        : 3ffe::303:300/120
NextHop        : ::ffff:10.20.1.1
Route Dist.    : 1:1234                VPN Label      : 131067
Path Id        : None
From           : 10.20.1.2
Res. NextHop   : n/a
Local Pref.    : 100                  Interface Name  : toA
Aggregator AS : None                  Aggregator     : None
Atomic Aggr.   : Not Atomic           MED            : 100
AIGP Metric    : None
Connector      : None
Community      : 0:0 target:100.100.100.100:2 target:1:123456
                origin:123456:2
Cluster        : 2.2.2.2
Originator Id  : 10.20.1.1            Peer Router Id  : 10.20.1.2
Flags          : Used Valid Best IGP
Route Source   : Internal
AS-Path        : No As-Path
Route Tag      : 0
Neighbor-AS    : N/A
Add Paths Send : Default
Last Modified  : 00h03m41s
VPRN Imported  : 3 1

Network        : ::/0
NextHop        : ::ffff:10.20.1.1
Route Dist.    : 100.100.100.100:2    VPN Label      : 131069
Path Id        : None
From           : 10.20.1.2
Res. NextHop   : n/a
Local Pref.    : 100                  Interface Name  : toA
Aggregator AS : None                  Aggregator     : None
Atomic Aggr.   : Not Atomic           MED            : 100
AIGP Metric    : None
Connector      : None
Community      : target:100.100.100.100:2 origin:100.100.100.100:2

```

```

origin:1:123456
Cluster      : 2.2.2.2
Originator Id : 10.20.1.1      Peer Router Id : 10.20.1.2
Flags       : Used Valid Best IGP
Route Source : Internal
AS-Path    : No As-Path
Route Tag   : 0
Neighbor-AS : N/A
Add Paths Send : Default
Last Modified : 00h03m42s
VPRN Imported : 1

Network      : 3ffe::100:0/104
NextHop     : ::ffff:10.20.1.1
Route Dist. : 100.100.100.100:2      VPN Label      : 131069
Path Id     : None
From       : 10.20.1.2
Res. NextHop : n/a
Local Pref. : 100
Aggregator AS : None                Interface Name : toA
Atomic Aggr. : Not Atomic          Aggregator     : None
AIGP Metric  : None                MED            : 100
Connector    : None
Community    : 100:100 2:3 target:100.100.100.100:2
              origin:1:123456 origin:1:2
Cluster      : 2.2.2.2
Originator Id : 10.20.1.1      Peer Router Id : 10.20.1.2
Flags       : Used Valid Best IGP
Route Source : Internal
AS-Path    : No As-Path
Route Tag   : 0
Neighbor-AS : N/A
Add Paths Send : Default
Last Modified : 00h03m42s
VPRN Imported : 1

Network      : 3ffe::101:0/112
NextHop     : ::ffff:10.20.1.1
Route Dist. : 100.100.100.100:2      VPN Label      : 131069
Path Id     : None
From       : 10.20.1.2
Res. NextHop : n/a
Local Pref. : 100
Aggregator AS : None                Interface Name : toA
Atomic Aggr. : Not Atomic          Aggregator     : None
AIGP Metric  : None                MED            : 100
Connector    : None
Community    : 100:100 2:3 target:100.100.100.100:2
              origin:100.100.100.100:2 origin:1:123456 origin:1:2
Cluster      : 2.2.2.2
Originator Id : 10.20.1.1      Peer Router Id : 10.20.1.2
Flags       : Used Valid Best IGP
Route Source : Internal
AS-Path    : No As-Path
Route Tag   : 0
Neighbor-AS : N/A
Add Paths Send : Default
Last Modified : 00h03m41s
VPRN Imported : 1

Network      : 3ffe::202:202/128
NextHop     : ::ffff:10.20.1.1
Route Dist. : 100.100.100.100:2      VPN Label      : 131069
Path Id     : None

```

```

From          : 10.20.1.2
Res. Nexthop  : n/a
Local Pref.   : 100
Aggregator AS : None
Atomic Aggr.  : Not Atomic
AIGP Metric   : None
Connector     : None
Community     : 0:0 target:100.100.100.100:2
               origin:100.100.100.100:2 origin:1:123456
Cluster       : 2.2.2.2
Originator Id : 10.20.1.1
Peer Router Id : 10.20.1.2
Flags         : Used Valid Best IGP
Route Source  : Internal
AS-Path       : No As-Path
Route Tag     : 0
Neighbor-AS   : N/A
Add Paths Send : Default
Last Modified : 00h03m41s
VPRN Imported : 1

Network       : ::/0
Nexthop      : ::ffff:10.20.1.1
Route Dist.   : 123456:2
Path Id       : None
VPN Label     : 131068
From          : 10.20.1.2
Res. Nexthop  : n/a
Local Pref.   : 100
Aggregator AS : None
Atomic Aggr.  : Not Atomic
AIGP Metric   : None
Connector     : None
Community     : target:100.100.100.100:2 origin:100.100.100.100:2
               origin:1:123456
Cluster       : 2.2.2.2
Originator Id : 10.20.1.1
Peer Router Id : 10.20.1.2
Flags         : Used Valid Best IGP
Route Source  : Internal
AS-Path       : No As-Path
Route Tag     : 0
Neighbor-AS   : N/A
Add Paths Send : Default
Last Modified : 00h03m41s
VPRN Imported : 1

Network       : 3ffe::100:0/104
Nexthop      : ::ffff:10.20.1.1
Route Dist.   : 123456:2
Path Id       : None
VPN Label     : 131068
From          : 10.20.1.2
Res. Nexthop  : n/a
Local Pref.   : 100
Aggregator AS : None
Atomic Aggr.  : Not Atomic
AIGP Metric   : None
Connector     : None
Community     : 100:100 2:3 target:100.100.100.100:2
               origin:1:123456 origin:1:2
Cluster       : 2.2.2.2
Originator Id : 10.20.1.1
Peer Router Id : 10.20.1.2
Flags         : Used Valid Best IGP
Route Source  : Internal
AS-Path       : No As-Path
Route Tag     : 0
Neighbor-AS   : N/A

```

```

Add Paths Send : Default
Last Modified  : 00h03m41s
VPRN Imported  : 1

Network       : 3ffe::101:0/112
Nextthop     : ::ffff:10.20.1.1
Route Dist.   : 123456:2           VPN Label      : 131068
Path Id       : None
From          : 10.20.1.2
Res. Nextthop : n/a
Local Pref.   : 100                Interface Name : toA
Aggregator AS : None                Aggregator     : None
Atomic Aggr.  : Not Atomic          MED             : 100
AIGP Metric   : None
Connector     : None
Community     : 100:100 2:3 target:100.100.100.100:2
                origin:100.100.100.100:2 origin:1:123456 origin:1:2

Cluster       : 2.2.2.2
Originator Id : 10.20.1.1           Peer Router Id  : 10.20.1.2
Flags         : Used Valid Best IGP
Route Source  : Internal
AS-Path       : No As-Path
Route Tag     : 0
Neighbor-AS   : N/A
Add Paths Send : Default
Last Modified  : 00h03m41s
VPRN Imported  : 1
    
```

```

Network       : 3ffe::202:202/128
Nextthop     : ::ffff:10.20.1.1
Route Dist.   : 123456:2           VPN Label      : 131068
Path Id       : None
From          : 10.20.1.2
Res. Nextthop : n/a
Local Pref.   : 100                Interface Name : toA
Aggregator AS : None                Aggregator     : None
Atomic Aggr.  : Not Atomic          MED             : 100
AIGP Metric   : None
Connector     : None
Community     : 0:0 target:100.100.100.100:2
                origin:100.100.100.100:2 origin:1:123456

Cluster       : 2.2.2.2
Originator Id : 10.20.1.1           Peer Router Id  : 10.20.1.2
Flags         : Used Valid Best IGP
Route Source  : Internal
AS-Path       : No As-Path
Route Tag     : 0
Neighbor-AS   : N/A
Add Paths Send : Default
Last Modified  : 00h03m41s
VPRN Imported  : 1
    
```

-----  
RIB Out Entries  
-----

Routes : 13  
=====

\*A: Sar18#

```
*A:7705:Dut-A>config>router# show router bgp routes bgp-ls
```

```
=====
BGP Router ID:10.0.0.1      AS:1001      Local AS:1001
```

```

=====
Legend -
Status codes : u - used, s - suppressed, h - history, d - decayed, * - valid
               l - leaked, x - stale, > - best, b - backup, p - purge
Origin codes  : i - IGP, e - EGP, ? - incomplete
=====
BGP-LS Node NLRIs
=====
Flag  Prot/Id                               Nexthop          LocalPref MED
      Local Node:AS/LsID/OSPF Ar Id
      IGP Rt Id
-----
*>i  OSPFv2/0                               1.13.0.3         n/a          None
      0.0.7.208/-/0.0.0.0
      10.0.0.4
*>i  OSPFv2/0                               1.13.0.3         n/a          None
      0.0.7.208/-/0.0.0.0
      10.0.0.6
-----
Routes : 2
=====
BGP-LS Link NLRIs
=====
Flag  Prot/Id                               Nexthop          LocalPref MED
      Local Node:AS/LsID/OSPF Ar Id
      IGP Rt Id
      Remote Node:AS/LsID/OSPF Ar Id
      IGP Rt Id
      Link: Local Id/Remote Id
      IPv4 Inf/Neighbor
      IPv6 Inf/Neighbor
-----
*>i  OSPFv2/0                               1.13.0.3         n/a          None
      0.0.7.208/-/0.0.0.0
      10.0.0.6
      0.0.7.208/-/0.0.0.0
      10.0.0.4
      -/-
      1.46.0.6/-
*>i  OSPFv2/0                               1.13.0.3         n/a          None
      0.0.7.208/-/0.0.0.0
      10.0.0.4
      0.0.7.208/-/0.0.0.0
      10.0.0.6
      -/-
      1.46.0.4/-
-----
Routes : 2
=====
BGP-LS Ipv4 NLRIs
=====
Flag  Prot/Id                               Nexthop          LocalPref MED
      Local Node:AS/LsID/OSPF Ar Id
      IGP Rt Id
      Prefix Desc:MT ID/OSPF Rt Type
      IP Reachability Addr/Prefix Len
-----
*>i  OSPFv2/0                               1.13.0.3         n/a          None
      0.0.7.208/-/0.0.0.0
      10.0.0.6
      -/Intra
      1.46.0.0/24
*>i  OSPFv2/0                               1.13.0.3         n/a          None
      0.0.7.208/-/0.0.0.0

```

```

10.0.0.4
-/Intra
10.0.0.4/32
*>i OSPFv2/0                1.13.0.3      n/a      None
0.0.7.208/-/0.0.0.0
10.0.0.6
-/Intra
10.0.0.6/32
*>i OSPFv2/0                1.13.0.3      n/a      None
0.0.7.208/-/0.0.0.0
10.0.0.4
-/Intra
1.46.0.0/24
-----
Routes : 4
-----
Total Routes : 8
=====
*A:7705:Dut-A>config>router#

```

```

*A:7705:Dut-A>config>router# show router bgp routes bgp-ls node
=====
BGP Router ID:10.0.0.1      AS:1001      Local AS:1001
=====
Legend -
Status codes : u - used, s - suppressed, h - history, d - decayed, * - valid
              l - leaked, x - stale, > - best, b - backup, p - purge
Origin codes : i - IGP, e - EGP, ? - incomplete
=====
BGP-LS Node NLRIs
=====
Flag  Prot/Id                Nexthop      LocalPref MED
      Local Node:AS/LsID/OSPF Ar Id
      IGP Rt Id
-----
*>i  OSPFv2/0                1.13.0.3      n/a      None
    0.0.7.208/-/0.0.0.0
    10.0.0.4
*>i  OSPFv2/0                1.13.0.3      n/a      None
    0.0.7.208/-/0.0.0.0
    10.0.0.6
-----
Routes : 2
=====
*A:7705:Dut-A>config>router#

```

```

*A:7705:Dut-A>config>router# show router bgp routes bgp-ls link
=====
BGP Router ID:10.0.0.1      AS:1001      Local AS:1001
=====
Legend -
Status codes : u - used, s - suppressed, h - history, d - decayed, * - valid
              l - leaked, x - stale, > - best, b - backup, p - purge
Origin codes : i - IGP, e - EGP, ? - incomplete
=====
BGP-LS Link NLRIs
=====
Flag  Prot/Id                Nexthop      LocalPref MED
      Local Node:AS/LsID/OSPF Ar Id
      IGP Rt Id
      Remote Node:AS/LsID/OSPF Ar Id
      IGP Rt Id

```

```

Link: Local Id/Remote Id
IPv4 Inf/Neighbor
IPv6 Inf/Neighbor
-----
*>i OSPFv2/0                                1.13.0.3      n/a      None
0.0.7.208/-/0.0.0.0
10.0.0.6
0.0.7.208/-/0.0.0.0
10.0.0.4
-/-
1.46.0.6/-
*>i OSPFv2/0                                1.13.0.3      n/a      None
0.0.7.208/-/0.0.0.0
10.0.0.4
0.0.7.208/-/0.0.0.0
10.0.0.6
-/-
1.46.0.4/-
-----
Routes : 2
=====
*A:7705:Dut-A>config>router#
    
```

```

*A:7705:Dut-A>config>router# show router bgp routes bgp-ls ipv4-prefix
=====
BGP Router ID:10.0.0.1      AS:1001      Local AS:1001
=====
Legend -
Status codes : u - used, s - suppressed, h - history, d - decayed, * - valid
               l - leaked, x - stale, > - best, b - backup, p - purge
Origin codes : i - IGP, e - EGP, ? - incomplete
=====
BGP-LS Ipv4 NLRIs
=====
Flag  Prot/Id                                Nexthop      LocalPref MED
Local Node:AS/LsID/OSPF Ar Id
IGP Rt Id
Prefix Desc:MT ID/OSPF Rt Type
IP Reachability Addr/Prefix Len
-----
*>i OSPFv2/0                                1.13.0.3      n/a      None
0.0.7.208/-/0.0.0.0
10.0.0.6
-/Intra
1.46.0.0/24
*>i OSPFv2/0                                1.13.0.3      n/a      None
0.0.7.208/-/0.0.0.0
10.0.0.4
-/Intra
10.0.0.4/32
*>i OSPFv2/0                                1.13.0.3      n/a      None
0.0.7.208/-/0.0.0.0
10.0.0.6
-/Intra
10.0.0.6/32
*>i OSPFv2/0                                1.13.0.3      n/a      None
0.0.7.208/-/0.0.0.0
10.0.0.4
-/Intra
1.46.0.0/24
-----
Routes : 4
=====
    
```



```
*A:7705:Dut-A>config>router#
```

Table 96: BGP route field descriptions

Label	Description
BGP Router ID	The local BGP router ID
AS	The configured autonomous system number
Local AS	The configured local AS setting. If not configured, the value is the same as the AS.
Flag/Flags	<p><b>Legend:</b></p> <p><b>Status codes:</b></p> <ul style="list-style-type: none"> <li>u - used</li> <li>s - suppressed</li> <li>h - history</li> <li>d - decayed</li> <li>* - valid</li> </ul> <p>If an * is not present, the status is invalid</p> <ul style="list-style-type: none"> <li>l - leaked</li> <li>x - stale</li> <li>&gt; - best</li> <li>b - backup</li> <li>p - purge</li> </ul> <p><b>Origin codes:</b></p> <ul style="list-style-type: none"> <li>i - IGP</li> <li>e - EGP</li> <li>? - incomplete</li> <li>&gt; - best</li> </ul>
Network	The IP prefix and mask length
Nexthop	The BGP next hop
AS-Path	The BGP AS path attribute
Local Pref.	The local preference value. This value is used if the BGP route arrives from a BGP peer without the Local Pref attribute set. It is overridden by any value set via a route policy.
MED	The MED metric value
	none: MED metrics are not present

Label	Description
VPN Label	The label generated by the PE label manager
Original Attributes	The received BGP attributes of a route from a peer without any modification from any policy
Modified Attributes	The final BGP attributes of a route after the policies evaluation
Route Dist.	The route distinguisher identifier attached to routes that distinguishes the VPN it belongs to
From	The advertising BGP neighbor IP address
Res. Nexthop	The resolved next hop
Aggregator AS	The aggregator AS value none: aggregator AS attributes are not present
Aggregator	The aggregator attribute value none: aggregator attributes are not present
Atomic Aggr.	Atomic: the atomic aggregator flag is set Not Atomic: the atomic aggregator flag is not set
Community	The BGP community attribute list
Cluster	The route reflector cluster list
Originator Id	The originator ID path attribute value none: the originator ID attribute is not present
Flags	The status of the route, either a status code (see Legend) or a text string
Peer Router Id	The router ID of the advertising router
TieBreakReason	The step in the BGP decision process where a BGP route lost the tiebreaker with the next BGP route for the same prefix LocalPref – this route is not the best because the next better route has a higher LOCAL_PREF AIGP – this route is not the best because the next better route has a lower derived AIGP metric value ASPathLen – this route is not the best because the next better route has a shorter AS PATH length Origin – this route is not the best because the next better route has a lower origin value

Label	Description
	<p>MED – this route is not the best because the next better route has a lower MED, and MED comparison of the routes was allowed</p> <p>IBGP – this IBGP route is not the best because the next better route is an EBGP route</p> <p>NHCost – this route is not the best because the next better route has a lower metric value to reach the BGP NEXT HOP</p> <p>BGPID – this route is not the best because the next better route has a lower originator ID or BGP identifier</p> <p>ClusterLen – this route is not the best because the next better route has a shorter cluster list length</p> <p>PeerIP – this route is not the best because the next better route has a lower neighbor IP address</p>
VPRN Imported	The VPRNs where a particular BGP-VPN received route has been imported and installed
BGP-LS Node NLRIs	BGP-LS NLRI of type Node
BGP-LS Link NLRIs	BGP-LS NLRI of type Link
BGP-LS Ipv4 NLRIs	BGP-LS NLRI of type IPv4 Prefix

## summary

### Syntax

**summary** [all]

**summary** [family *family*] [neighbor *ip-address*]

### Context

show>router>bgp

### Description

This command displays a summary of BGP neighbor information.

If confederations are not configured, that portion of the output will not display.

The "State" field displays the global BGP operational state. The valid values are:

- Up – BGP global process is configured and running
- Down – BGP global process is administratively shut down and not running
- Disabled – BGP global process is operationally disabled. The process must be restarted by the operator.

For example, if a BGP peer is operationally disabled, then the state in the summary table shows the state 'Disabled'.

## Parameters

### all

displays BGP peers in all instances

### family

displays only those BGP peers that have the specified address family enabled

**Values** ipv4 | vpn-ipv4 | ipv6 | vpn-ipv6 | mvpn-ipv4 | route-target | evpn | label-ipv4 | label-ipv6 | bgp-ls

### ip-address

clears damping information for entries received from the BGP neighbor

## Output

The following output is an example of BGP summary information, and [Table 97: BGP summary field descriptions](#) describes the fields.

### Output example

```
*A:7705_ALU-2>show>router>bgp# summary
=====
BGP Router ID : 10.55.55.1      AS : 65000   Local AS : 65000
=====
BGP Admin State      : Up          BGP Oper State      : Up
Total Peer Groups    : 1           Total Peers          : 1
Total BGP Paths       : 74         Total Path Memory    : 9128
Total IPv4 Remote Rts : 600       Total IPv4 Rem. Active Rts : 563

Total Supressed Rts  : 0           Total Hist. Rts     : 0
Total Decay Rts      : 0

Total VPN Peer Groups : 0           Total VPN Peers     : 0
Total VPN Local Rts   : 8672
Total VPN-IPv4 Rem. Rts : 8656       Total VPN-IPv4 Rem. Act. Rts: 8656

Total VPN Supp. Rts   : 0           Total VPN Hist. Rts : 0
Total VPN Decay Rts   : 0
=====
BGP Summary
=====
Legend : D - Dynamic Neighbor
=====
Neighbor
      AS PktRcvd InQ  Up/Down  State|Rcv/Act/Sent (Addr Family)
      PktSent OutQ
-----
10.44.10.12
      65000    654   0 04h11m01s 600/563/569 (IPv4)
              557   0                8656/8656/8672 (VpnIPv4)

10.100.1.3(D)
      65000    21   0 00h06m08s 5/0/7 (IPv4)
              18   0                2/0/4 (IPv6)
              0/0/0 (VpnIPv4)
              0/0/0 (VpnIPv6)
=====
```

```
*A:7705_ALU-2>show>router>bgp#
```

```
*A:7705_ALU-2>show>router>bgp# summary all
```

```
=====
BGP Summary
=====
```

```
Legend : D - Dynamic Neighbor
=====
```

```
Neighbor
```

```
Description
ServiceId          AS PktRcvd InQ Up/Down  State|Rcv/Act/Sent (Addr Family)
                   PktSent OutQ
```

```
-----
10.44.10.12
Def. Instance      65000      662    0 04h14m52s 600/563/569 (IPv4)
                   564      0
                   8656/8656/8672 (VpnIPv4)

10.100.1.3(D)
                   65000      21     0 00h06m08s 5/0/7 (IPv4)
                   18     0
                   2/0/4 (IPv6)
                   0/0/0 (VpnIPv4)
                   0/0/0 (VpnIPv6)
=====
```

```
*A:7705_ALU-2>show>router>bgp#
```

```
*A:7705_ALU-2>show>router>bgp# summary neighbor 10.44.10.12
```

```
=====
BGP Router ID : 10.44.10.1      AS : 65000      Local AS : 65000
=====
```

```
BGP Admin State      : Up          BGP Oper State      : Up
Total Peer Groups    : 1            Total Peers          : 1
Total BGP Paths       : 74           Total Path Memory    : 9128
Total IPv4 Remote Rts : 600         Total IPv4 Rem. Active Rts : 563
Total Suppressed Rts  : 0            Total Hist. Rts      : 0
Total Decay Rts       : 0

Total VPN Peer Groups : 0            Total VPN Peers      : 0
Total VPN Local Rts   : 8672
Total VPN-IPv4 Rem. Rts : 8656       Total VPN-IPv4 Rem. Act. Rts: 8656
Total VPN Supp. Rts   : 0            Total VPN Hist. Rts  : 0
Total VPN Decay Rts   : 0
```

```
=====
BGP Summary
=====
```

```
Legend : D - Dynamic Neighbor
=====
```

```
Neighbor
```

```
AS PktRcvd InQ Up/Down  State|Rcv/Act/Sent (Addr Family)
PktSent OutQ
```

```
-----
10.44.10.12
                   65000      673    0 04h20m24s 600/563/569 (IPv4)
                   575      0
                   8656/8656/8672 (VpnIPv4)

10.100.1.3(D)
                   65000      21     0 00h06m08s 5/0/7 (IPv4)
                   18     0
                   2/0/4 (IPv6)
                   0/0/0 (VpnIPv4)
                   0/0/0 (VpnIPv6)
=====
```

```
*A:7705_ALU-2>show>router>bgp#
```

```
*A:7705_ALU-2>show>router>bgp# summary family ipv4
```

```
=====
BGP Router ID : 10.44.10.1      AS : 65000    Local AS : 65000
=====
BGP Admin State      : Up          BGP Oper State      : Up
Total Peer Groups   : 1           Total Peers         : 1
Total BGP Paths     : 74          Total Path Memory   : 9128
Total IPv4 Remote Rts : 600       Total IPv4 Rem. Active Rts : 563

Total Suppressed Rts : 0          Total Hist. Rts     : 0
Total Decay Rts     : 0

Total VPN Peer Groups : 0          Total VPN Peers     : 0
Total VPN Local Rts   : 8672       Total VPN-IPv4 Rem. Act. Rts: 8656
Total VPN-IPv4 Rem. Rts : 8656

Total VPN Supp. Rts  : 0          Total VPN Hist. Rts : 0
Total VPN Decay Rts  : 0
=====
```

BGP IPv4 Summary

Legend : D - Dynamic Neighbor

Neighbor

	AS	PktRcvd	PktSent	InQ	OutQ	Up/Down	State Recv/Actv/Sent
10.44.10.12	65000	679	581	0	0	04h23m36s	600/563/569

```
*A:7705_ALU-2>show>router>bgp#
```

```
*A:7705:Dut-A# show router bgp summary neighbor 10.0.0.3 family ipv6
```

```
=====
BGP Router ID:10.0.0.1      AS:1001      Local AS:1001
=====
BGP Admin State      : Up          BGP Oper State      : Up
Total IPv4 Remote Rts : 0          Total IPv4 Rem. Active Rts : 0
Total McIPv4 Remote Rts : 0        Total McIPv4 Rem. Active Rts: 0
Total IPv6 Remote Rts : 0          Total IPv6 Rem. Active Rts : 0
Total IPv4 Backup Rts : 0          Total IPv6 Backup Rts   : 0

Total VPN-IPv4 Rem. Rts : 0          Total VPN-IPv4 Rem. Act. Rts: 0
Total VPN-IPv6 Rem. Rts : 0          Total VPN-IPv6 Rem. Act. Rts: 0
Total VPN-IPv4 Bkup Rts : 0          Total VPN-IPv6 Bkup Rts   : 0

Total MVPN-IPv4 Rem Rts : 0          Total MVPN-IPv4 Rem Act Rts : 0
Total RouteTgt Rem Rts : 0          Total RouteTgt Rem Act Rts : 0
Total EVPN Rem Rts     : 0          Total EVPN Rem Act Rts     : 0
Total LblIpv4 Rem Rts  : 0          Total LblIpv4 Rem. Act Rts  : 0
Total LblIpv6 Rem Rts  : 0          Total LblIpv6 Rem. Act Rts  : 0
Total LblIpv4 Bkp Rts  : 0          Total LblIpv6 Bkp Rts      : 0
Total Link State Rem Rts: 8          Total Link State Rem. Act Rts:0
Bgp-Ls Suppr. Pfxs    : 0          Bgp-Ls Recd. Pfxs         :0
Bgp-Ls Active Pfxs    : 0          Bgp-Ls Rej. Pfxs         :0
=====
```

BGP IPv6 Summary

Legend : D - Dynamic Neighbor

```
Neighbor
      AS PktRcvd PktSent  InQ  OutQ  Up/Down  State|Recv/Actv/Sent
-----
10.0.0.3
      1000      23      25   0    0 00h03m09s 0/0/0
-----
*A:7705:Dut-A#
```

Table 97: BGP summary field descriptions

Label	Description
BGP Router ID	The local BGP router ID
AS	The configured autonomous system number
Local AS	The configured local AS setting. If not configured, then the value is the same as the AS.
BGP Admin State	Down: BGP is administratively disabled
	Up: BGP is administratively enabled
BGP Oper State	Down: BGP is operationally disabled
	Up: BGP is operationally enabled
Total Peer Groups	The total number of configured BGP peer groups
Total Peers	The total number of configured BGP peers
Total BGP Paths	The total number of unique sets of BGP path attributes learned from BGP peers
Total Path Memory	The total amount of memory used to store the path attributes
Total IPv4 Remote Rts	The total number of IPv4 routes learned from BGP peers
Total IPv4 Remote Act. Rts	The total number of IPv4 routes used in the forwarding table
Total Suppressed Rts	The total number of suppressed routes due to route damping
Total Hist. Rts	The total number of routes with history due to route damping
Total Decay Rts	The total number of decayed routes due to route damping
Total VPN Peer Groups	The total number of configured VPN peer groups
Total VPN Peers	The total number of configured VPN peers

Label	Description
Total VPN Local Rts	The total number of configured local VPN routes
Total VPN-IPv4 Rem. Rts	The total number of configured remote VPN-IPv4 routes
Total VPN-IPv4 Rem. Act. Rts	The total number of active remote VPN-IPv4 routes used in the forwarding table
Total VPN Suppr. Rts	The total number of suppressed VPN routes due to route damping
Total VPN Hist. Rts	The total number of VPN routes with history due to route damping
Total VPN Decay Rts	The total number of decayed routes due to route damping
Total Link State Rem Rts	The total number of link-state routes
Total Link State Rem. Act Rts	The total number of active link-state routes
Bgp-Ls Suppr. Pfxs	The total number of BGP-LS suppressed prefixes
Bgp-Ls Recd. Pfxs	The total number of BGP-LS received prefixes
Bgp-Ls Active Pfxs	The total number of BGP-LS active prefixes
Bgp-Ls Rej. Pfxs	The total number of BGP-LS rejected prefixes
Neighbor	The BGP neighbor address
AS (Neighbor)	The BGP neighbor autonomous system number
PktRcvd	The total number of packets received from the BGP neighbor
PktSent	The total number of packets sent to the BGP neighbor
InQ	The number of BGP messages to be processed
OutQ	The number of BGP messages to be transmitted
Up/Down	The amount of time that the BGP neighbor has either been established or not established depending on its current state
State Recv/Actv/Sent (Addr Family)	The BGP neighbor's current state (if not established) or the number of received routes, active routes and sent routes (if established), along with the address family



### 6.13.2.3 Clear commands

#### flap-statistics

##### Syntax

**flap-statistics** [{*ip-prefix/mask* [**neighbor** *ip-address*] | **group** *group-name* | **regex** *reg-exp* | **policy** *policy-name*}]

##### Context

clear>router>bgp

##### Description

This command clears route flap statistics.

##### Parameters

*ip-prefix/mask*

clears route flap statistics for entries that match the specified IP prefix and mask length

<b>Values</b>	<i>ip-prefix</i>	a.b.c.d (host bits must be 0)
	<i>mask:</i>	0 to 32

*ip-address*

clears route flap statistics for entries received from the specified BGP neighbor

<b>Values</b>	<i>ipv4-address:</i>	a.b.c.d
---------------	----------------------	---------

*group-name*

clears route flap statistics for entries received from any BGP neighbors in the specified peer group

*reg-exp*

clears route flap statistics for all entries that have the regular expression and the AS path that matches the regular expression

*policy-name*

clears route flap statistics for entries that match the specified route policy

#### neighbor

##### Syntax

**neighbor** {*ip-address* | **as** *as-number* | **external** | **all**} [**soft** | **soft-inbound** | **hard**]

**neighbor** {*ip-address* | **as** *as-number* | **external** | **all**} **statistics**

**neighbor** *ip-address* **end-of-rib**

## Context

clear>router>bgp

## Description

This command resets the specified BGP peer or peers. This can cause existing BGP connections to be shut down and restarted.

## Parameters

### *ip-address*

resets the BGP neighbor with the specified IP address

**Values** *ipv4-address:* a.b.c.d

### *as-number*

resets all BGP neighbors with the specified peer AS

**Values** 1 to 4294967295

### **external**

resets all EBGp neighbors

### **all**

resets all BGP neighbors

### **soft**

the specified BGP neighbors re-evaluate all routes in the Local-RIB against the configured export policies

### **soft-inbound**

the specified BGP neighbors re-evaluate all routes in the RIB-In against the configured import policies

### **hard**

resets the BGP peering session by closing the TCP session and starting a new session. Before the peer goes down, a NOTIFICATION message is sent to the peer with the error code 'Cease' and the reset subcode 'Hard'.

### **statistics**

the BGP neighbor statistics

### **end-of-rib**

clears the routing information base (RIB)

## protocol

## Syntax

**protocol**

## Context

clear>router>bgp

## Description

This command resets the entire BGP protocol.

## 6.13.2.4 Debug commands

### events

#### Syntax

**events** [*neighbor ip-address* | **group name**]

**no events**

#### Context

debug>router>bgp

#### Description

This command logs all events changing the state of a BGP peer.

#### Parameters

*ip-address*

debugs only events affecting the specified BGP neighbor

**Values** *ipv4-address*: a.b.c.d (host bits must be 0)

*name*

debugs only events affecting the specified peer group and associated neighbors

### graceful-restart

#### Syntax

**graceful-restart** [*neighbor ip-address* | **group name**]

**no graceful-restart**

#### Context

debug>router>bgp

#### Description

This command enables debugging for BGP graceful restart.

The **no** form of the command disables the debugging.

## Parameters

*ip-address*

debugs only events affecting the specified BGP neighbor

**Values** *ipv4-address:* a.b.c.d (host bits must be 0)

*name*

debugs only events affecting the specified peer group and associated neighbors

## keepalive

### Syntax

**keepalive** [**neighbor** *ip-address* | **group** *name*]

**no keepalive**

### Context

debug>router>bgp

### Description

This command decodes and logs all sent and received Keepalive messages in the debug log.

## Parameters

*ip-address*

debugs only events affecting the specified BGP neighbor

**Values** *ipv4-address:* a.b.c.d (host bits must be 0)

*name*

debugs only events affecting the specified peer group and associated neighbors

## notification

### Syntax

**notification** [**neighbor** *ip-address* | **group** *name*]

**no notification**

### Context

debug>router>bgp

### Description

This command decodes and logs all sent and received Notification messages in the debug log.

## Parameters

*ip-address*

debugs only events affecting the specified BGP neighbor

**Values** *ipv4-address*: a.b.c.d (host bits must be 0)

*name*

debugs only events affecting the specified peer group and associated neighbors

## open

### Syntax

**open** [**neighbor** *ip-address* | **group** *name*]

**no open**

### Context

debug>router>bgp

### Description

This command decodes and logs all sent and received Open messages in the debug log.

## Parameters

*ip-address*

debugs only events affecting the specified BGP neighbor

*name*

debugs only events affecting the specified peer group and associated neighbors

## outbound-route-filtering

### Syntax

[**no**] **outbound-route-filtering**

### Context

debug>router>bgp

### Description

This command enables debugging for all BGP outbound route filtering (ORF) packets. ORF is used to inform a neighbor of targets (using target-list) that it is willing to receive.

## packets

### Syntax

**packets** [*neighbor ip-address* | **group name**]

**packets**

### Context

debug>router>bgp

### Description

This command decodes and logs all sent and received BGP packets in the debug log.

### Parameters

*ip-address*

debugs only events affecting the specified BGP neighbor

**Values** *ipv4-address*: a.b.c.d (host bits must be 0)

*name*

debugs only events affecting the specified peer group and associated neighbors

## route-refresh

### Syntax

**route-refresh** [*neighbor ip-address* | **group name**]

**no route-refresh**

### Context

debug>router>bgp

### Description

This command enables and disables debugging for BGP route refresh.

### Parameters

*ip-address*

debugs only events affecting the specified BGP neighbor

**Values** *ipv4-address*: a.b.c.d (host bits must be 0)

*name*

debugs only events affecting the specified peer group and associated neighbors

## rtm

### Syntax

**rtm** [*neighbor ip-address* | **group name**]

**no rtm**

### Context

debug>router>bgp

### Description

This command logs RTM changes in the debug log.

### Parameters

*ip-address*

debugs only events affecting the specified BGP neighbor

**Values** *ipv4-address*: a.b.c.d (host bits must be 0)

*name*

debugs only events affecting the specified peer group and associated neighbors

## socket

### Syntax

**socket** [*neighbor ip-address* | **group name**]

**no socket**

### Context

debug>router>bgp

### Description

This command logs all TCP socket events to the debug log.

### Parameters

*ip-address*

debugs only events affecting the specified BGP neighbor

**Values** *ipv4-address*: a.b.c.d (host bits must be 0)

*name*

debugs only events affecting the specified peer group and associated neighbors

## timers

### Syntax

**timers** [*neighbor ip-address* | **group name**]

**no timers**

### Context

debug>router>bgp

### Description

This command logs all BGP timer events to the debug log.

### Parameters

*ip-address*

debugs only events affecting the specified BGP neighbor

**Values** *ipv4-address*: a.b.c.d (host bits must be 0)

*name*

debugs only events affecting the specified peer group and associated neighbors

## update

### Syntax

**update** [*neighbor ip-address* | **group name**]

**no update**

### Context

debug>router>bgp

### Description

This command decodes and logs all sent and received Update messages in the debug log.

### Parameters

*ip-address*

debugs only events affecting the specified BGP neighbor

**Values** *ipv4-address*: a.b.c.d (host bits must be 0)

*name*

debugs only events affecting the specified peer group and associated neighbors



## 7 RIP

This chapter provides information about configuring RIP on the 7705 SAR.

Topics in this chapter include:

- [RIP overview](#)
- [RIP configuration process overview](#)
- [Configuration notes](#)
- [Configuring RIP with CLI](#)
- [RIP command reference](#)

### 7.1 RIP overview

Routing Information Protocol (RIP) is an interior gateway protocol (IGP) that uses a Bellman-Ford distance-vector algorithm to determine the best route to a destination, using hop count as the metric. In order for the protocol to provide complete information on routing, every router in the domain must participate in the protocol.

The 7705 SAR supports RIPv1 and RIPv2 on all IP network interfaces and on IES and VPRN access interfaces.

RIPv1, specified in RFC 1058, was written and implemented prior to the introduction of CIDR. The RIPv1 protocol does not send subnet mask information during routing updates; instead, it assumes the subnet mask information for non-local routes based on the class the route belongs to:

- Class A – 8-bit mask
- Class B – 16-bit mask
- Class C – 24-bit mask

RIPv2, as defined in RFC 2453, was written after CIDR was developed and transmits subnet mask information with every route. Because of the support for CIDR routes and other enhancements in RIPv2 such as triggered updates, multicast advertisements, and authentication, most production networks use RIPv2. However, some older hosts and routers only support RIPv1, especially when RIP is used simply to advertise default routing information.

RIP, which is carried over the UDP protocol, updates its neighbors, and the neighbors update their neighbors, and so on. Each host that uses RIP has a routing process that sends and receives datagrams on UDP port number 520. Although the RIP mechanism is fairly simple, it requires a lot of convergence time in large networks and is prone to routing loops unless additional measures are taken.

Each RIP router advertises all RIP routes periodically via RIP updates. By default, each update can contain a maximum of 25 route advertisements. This limit is imposed by RIP specifications. RIP can be configured to send as many as 255 routes per update. RIPv1 and RIPv2 updates are formatted slightly differently. RIPv1 updates are sent to a broadcast address (255.255.255.255); RIPv2 updates can be sent either to a broadcast or multicast address (224.0.0.9).

A network address of 0.0.0.0 is considered a default route. A default route is used when it is not convenient to list every possible network in the RIP updates and when one or more closely connected gateways in the system are prepared to handle traffic to the networks that are not listed explicitly. These gateways create RIP entries for the address 0.0.0.0 as if it were a network to which they are connected.

### 7.1.1 RIP versions

You can specify the RIP version that will be sent to RIP neighbors and the version of RIP updates that will be accepted and processed. The 7705 SAR allows the following combinations:

- send only RIPv1 or RIPv2 messages to either the broadcast or multicast address, or send no messages

If the sending router's RIP interface is configured to send to the broadcast address, the receiving router interface must be configured to allow directed broadcasts in the **config>router>interface** context (for network interfaces), in the **config>service>ies>interface** context (for IES interfaces), or in the **config>service>vprn>interface** context (for VPRN interfaces). The 7705 SAR sends RIPv2 formatted messages to the broadcast address by default.

- receive only RIPv1 updates, receive only RIPv2 updates, receive both RIPv1 and RIPv2 updates, or receive no updates

The 7705 SAR receives both RIPv1 and RIPv2 updates by default.

### 7.1.2 RIPv2 authentication

RIPv2 messages carry more information than RIPv1 messages, which permits the use of a simple authentication mechanism to secure table updates. The 7705 SAR RIPv2 implementation enables the use of a plaintext (simple) password or message digest (MD5) authentication.

### 7.1.3 Metrics

By default, RIP advertises all RIP routes to each peer every 30 s. RIP uses a hop count metric to determine the distance between the packet's source and destination. The metric/cost value for a valid route is 1 through 15.

Each router along the path increments the hop count value by 1. When a router receives a routing update with new or different destination information, the metric increments by 1.

The maximum number of hops in a path is 15. The router treats any number over 15 as infinitely large. If a router receives a routing update with a metric of 15 that contains a new or modified entry, the route metric value increments to 16 and the destination is considered unreachable.

The 7705 SAR uses split horizon and split horizon with poison reverse to avoid looping routes propagating through the network. When split horizon is enabled, the local router does not readvertise routes learned from a neighbor back to the same neighbor. When split horizon with poison is enabled and the router receives an update over an interface, the router sets the route metric to 16 (infinity) and advertises the route back to the network where it is now considered unreachable.

### 7.1.4 Timers

RIP uses three timers to determine how often RIP updates are sent and how long routes are maintained:

- update – times the interval between periodic routing updates
- timeout – initialized when a route is established and any time an update message is received for the route. When this timer expires, the route is no longer valid. It is retained in the table for a short time so that neighbors can be notified that the route has been dropped.
- flush – when the flush timer expires, the route is removed from the tables

### 7.1.5 Import and export policies

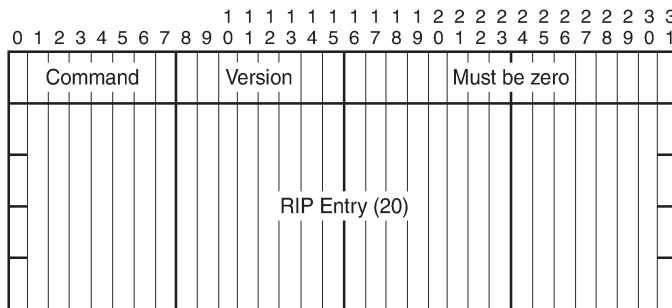
Routing policies control the content of the routing tables, the routes that are advertised, and the best route to take to reach a destination. Import route policies determine which routes are accepted from RIP neighbors. Export route policies determine which routes are exported from the route table to RIP.

There are no default import or export routing policies. Policies must be explicitly created and applied with RIP import or export commands.

### 7.1.6 RIP packet format

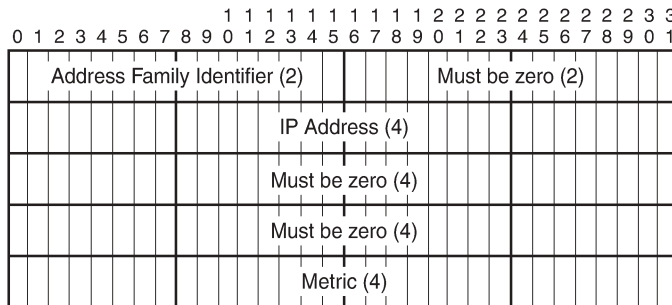
There can be 1 to 25 route entries. The RIP packet header format is displayed in [Figure 47: RIP packet format](#). [Figure 48: RIPv1 packet format](#) and [Figure 49: RIPv2 packet format](#) display the RIPv1 and RIPv2 packet formats.

Figure 47: RIP packet format



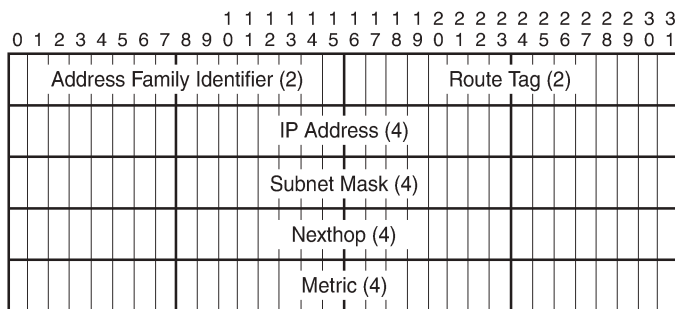
23174

Figure 48: RIPv1 packet format



23175

Figure 49: RIPv2 packet format



23176

RIP packets contain the following fields:

- Command – indicates whether the packet is a request or a response message. A request message asks the responding system to send all or part of its routing table. The response message may be sent in response to a request, or it may be an unsolicited routing update generated by the sender.
- Version – specifies the RIP version used and can be used to signal different, and potentially incompatible, versions
- Must be zero – provides backward compatibility with pre-standard varieties of RIP. RIP messages with non-zero values in this field are rejected unless the check-zero command is disabled.
- Address family identifier (AFI) – the type of address. RIP can carry routing information for several different protocols. Each entry in this field has an AFI to indicate the type of address being specified. The IP AFI is 2.
- IP Address – the IP address for the packet
- Metric – specifies the number of hops to the destination
- Next hop – the IP address of the next router along the path to the destination. This field appears only in RIPv2 packets.
- Subnet mask – the subnet mask for the entry. If this field is 0, no subnet mask has been specified for the entry. This field appears only in RIPv2 packets.

### 7.1.7 RIP hierarchical levels

The minimum RIP configuration must define one group and one neighbor. The parameters configured at the RIP global level are inherited by the group and neighbor levels. Parameters can be modified and overridden on a level-specific basis. The RIP command hierarchy consists of three levels:

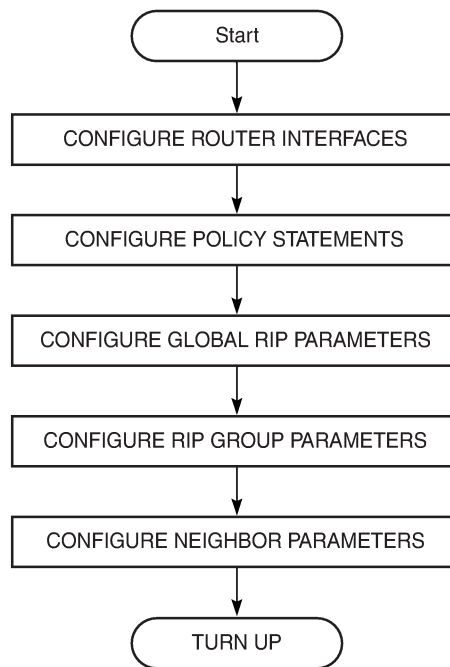
- global
- group
- neighbor

Hierarchical RIP commands can be modified on different levels. The most specific value is used. A RIP group-specific command takes precedence over a global RIP command. A neighbor-specific command takes precedence over a global RIP or group-specific RIP command.

## 7.2 RIP configuration process overview

The following figure displays the process to configure RIP parameters.

Figure 50: RIP configuration and implementation flow



23177

## 7.3 Configuration notes

The following guidelines and caveats apply to RIP configuration:

- Before RIP neighbor parameters can be configured, router interfaces must be configured.
- RIP must be explicitly created for each router interface. There are no default RIP instances on a 7705 SAR router.

## 7.4 Configuring RIP with CLI

This section provides information about configuring RIP using the command line interface.

Topics in this section include:

- [RIP configuration overview](#)
- [Basic RIP configuration](#)
- [Common configuration tasks](#)

- [Configuring RIP parameters](#)
- [RIP configuration management tasks](#)

## 7.5 RIP configuration overview

### 7.5.1 Preconfiguration requirements

Before RIP can be implemented, the following entities must be configured:

- policy statements must be defined in the **config>router>policy-options** context

## 7.6 Basic RIP configuration

RIP is configured in the **config>router>rip** context for network interfaces and IES access interfaces. RIP is configured in the **config>service>vprn>rip** context for VPRN interfaces when RIP is used as a PE-to-CE routing protocol for VPRN service. For information about configuring RIP under VPRN, see the 7705 SAR Services Guide, "Configuring RIP for VPRN".

RIP configuration commands have three primary configuration levels: **rip** for global configurations, **group group-name** for RIP groups, and **neighbor ip-int-name** for RIP neighbor configurations. Within the different levels, the configuration commands are identical.

Commands and parameters configured at the global level are inherited by the group and neighbor level; however, the command that is most specific to the neighboring router takes precedence. Parameters configured at the neighbor level have precedence over group and global configurations and parameters configured at the group level have precedence over global configurations.

The minimum RIP parameters that must be configured in the **config>router>rip** context are:

- group
- neighbor

For a router to accept RIP updates, at least one group and one neighbor must be defined. A 7705 SAR router ignores RIP updates received from routers on interfaces not configured for RIP. Configuring other RIP commands and parameters is optional.

By default, the local router imports all routes from its neighbor and does not advertise routes. The router receives both RIPv1 and RIPv2 update messages with 25 to 255 route entries per message.

The following is an example of a basic RIP configuration.

```
ALU-A>config>router>rip# info
-----
      group "RIP-ALU-A"
        neighbor "to-ALU-4"
        exit
      exit
-----
ALU-A>config>router>rip#
```

## 7.7 Common configuration tasks

This section provides a brief overview of the tasks that must be performed to configure RIP and provides the CLI commands.

RIP is configured hierarchically; the global level applies to all peers, the group level applies to all peers in the group, and the neighbor level only applies to a specified peer. By default, group members inherit the group's configuration parameters, although a parameter can be modified on a per-member basis without affecting the group-level parameters.

All RIP instances must be explicitly created on each 7705 SAR. Once created, RIP is administratively enabled.

To configure RIP, perform the following tasks in order:

- configure interfaces
- configure policy statements (optional)
- enable RIP
- configure group parameters
- configure neighbor parameters

### 7.7.1 Configuring interfaces

The following command sequences create a logical IP interface. The logical interface can associate attributes such as an IP address, port, link aggregation group (LAG), or the system. For more information about configuring interfaces, see the 7705 SAR Router Configuration Guide.

To configure a network interface:

#### CLI syntax:

```
config>router
  interface ip-int-name
    address {ip-addr/mask-length | ip-addr/netmask}
    allow-directed-broadcasts
    port port-name
```

#### Example:

```
config>router# interface "to-ALU-4"
config>router>if# address 10.10.12.1/8
config>router>if# port 1/1/1
config>router>if# exit
```

The following example displays the configuration output:

```
ALU-3>config>router# info
-----
#echo "IP Configuration"
#-----
  interface "system"
    address 192.0.2.0/24
  exit
  interface "to-ALU-4"
    address 10.10.12.1/8
```

```

        port 1/1/1
        exit
#-----
ALU-3>config>router#

```

The following command sequences create an IES (access) interface that will be added to RIP in the **config>router>rip** context. For more information about IES interfaces, see the 7705 SAR Services Guide, "Internet Enhanced Service".

To configure an IES interface:

#### CLI syntax:

```

config>service
  ies service-id [customer customer-id] [create] [vpn vpn-id]
  interface ip-int-name [create]
    address {ip-addr/mask | ip-addr/netmask}
    allow-directed-broadcasts
    sap sap-id [create]

```

#### Example:

```

config>service# ies 4 customer 1 create
config>service>ies# interface "rip_interface" create
config>service>ies>if$ address 172.16.1.1/12
config>service>ies>if$ allow-directed-broadcasts
config>service>ies>if$ sap 1/1/4 create

```

The following example displays the configuration output:

```

*A: Sar18 Dut-B>config>service>ies# info
-----
      interface "rip_interface" create
        address 172.16.1.1/12
        allow-directed-broadcasts
        sap 1/1/4 create
        exit
      exit
      no shutdown
-----
*A: Sar18 Dut-B>config>service>ies#

```

## 7.7.2 Configuring a route policy

The import route policy command allows you to filter routes being imported by the local router from its neighbors. If no match is found, the local router does not import any routes.

The export route policy command allows you to determine which routes are exported from the route table to RIP. By default, RIP does not export routes it has learned to its neighbors. If no export policy is specified, non-RIP routes will not be exported from the routing table manager to RIP.

If multiple policy names are specified, the policies are evaluated in the order they are specified. The first policy that matches is applied. If multiple export commands are issued, the last command entered will override the previous command. A maximum of five policy names can be specified.

To enter the mode to create or edit route policies, you must enter the **begin** keyword at the **config>router>policy-options** prompt. Other editing commands include:

- the **commit** command, saves and enables changes made to route policies during a session



- the **abort** command, discards changes that have been made to route policies during a session

Use the following CLI syntax to configure a policy to use for RIP global, group, and neighbor import and export commands. This section provides brief instructions to configure route policies. For more details and the complete list of policy options commands, see the 7705 SAR Router Configuration Guide, "Configuring Route Policies With CLI".

#### CLI syntax:

```
config>router>policy-options
  begin
  commit
  abort
  policy-statement name
    description text
    default-action {accept | next-entry | next-policy | reject}
    entry entry-id
      description text
      action {accept | next-entry | next-policy | reject}
      from
        protocol {bgp | direct | ospf | ospf3 | rip | isis |
static | aggregate | bgp-vpn | igmp | mld | pim | ldp}
        to
          protocol {bgp | direct | ospf | ospf3 | rip | isis |
static | aggregate | bgp-vpn | igmp | mld | pim | ldp}
```

The following example displays commands to configure a policy statement. Use the **commit** command to save the changes.

#### Example:

```
config>router>policy-options# begin
policy-options# policy-statement "RIP-policy"
policy-options>policy-statement$ description "this is a
test RIP policy"
policy-options>policy-statement>default# entry 1
policy-options>policy-statement>entry$ action accept
policy-options>policy-statement>entry# exit
policy-options>policy-statement# default-action reject
policy-options>policy-statement# exit
policy-options# commit
```

```
ALU-A>config>router>policy-options# info
-----
  policy-statement "RIP-policy"
  description "this is a test RIP policy"
  entry 1
  action accept
  exit
  exit
  default-action reject
  exit
-----
ALU-A>config>router>policy-options>policy-statement#
```

## 7.8 Configuring RIP parameters

Use the CLI syntax below to configure global-level, group-level, and neighbor-level parameters:

### CLI syntax:

```

config>router
  rip
    authentication-key {authentication-key | hash-key} [hash | hash2]
    authentication-type {none | password | message-digest | message-
digest-20}
    check-zero {enable | disable}
    description description-string
    export policy-name [policy-name ...up to 5 max]
    group group-name
      authentication-key {authentication-key | hash-key} [hash |
hash2]
      authentication-type {none | password | message-digest |
message-digest-20}
      check-zero {enable | disable}
      description description-string
      export policy-name [policy-name ...up to 5 max]]
      import policy-name [policy-name ...up to 5 max]]
      message-size max-num-of-routes
      metric-in metric
      metric-out metric
      neighbor ip-int-name
        authentication-key {authentication-key | hash-key} [hash|
hash2]
        authentication-type {none | password | message-digest |
message-digest-20}
        check-zero {enable | disable}
        description description-string
        export policy-name [policy-name ...up to 5 max]]
        import policy-name [policy-name ...up to 5 max]]
        message-size max-num-of-routes
        metric-in metric
        metric-out metric
        preference preference
        receive receive-type
        send send-type
        no shutdown
        split-horizon {enable | disable}
        timers update timeout flush
      preference preference
      receive receive-type
      send send-type
      no shutdown
      split-horizon {enable|disable}
      timers update timeout flush
    import policy-name [policy-name ...up to 5 max]
    message-size max-num-of-routes
    metric-in metric
    metric-out metric
    preference preference
    receive receive-type
    send send-type
    no shutdown
    split-horizon {enable | disable}
    timers update timeout flush

```

## 7.8.1 Configuring global-level parameters

Once the RIP protocol instance is created, it is administratively enabled automatically; the **no shutdown** command is not required. To enable RIP on a router, at least one group and one neighbor must be configured. There are no default groups or neighbors. Each group and neighbor must be explicitly configured.



**Note:** Careful planning is essential to implement commands that can affect the behavior of global, group, and neighbor levels. Because the RIP commands are hierarchical, analyze the values that can disable features on a particular level.

The following example displays a global RIP configuration:

### Example:

```
config>router# rip
config>router>rip# authentication-type password
config>router>rip# authentication-key test123
config>router>rip# receive both
config>router>rip# split-horizon enable
config>router>rip# timers 300 600 600
config>router>rip>group# exit
```

```
ALU-A>config>router>rip# info
-----
authentication-type simple
authentication-key "acl865lvz1d" hash
timers 300 600 600
-----
```

## 7.8.2 Configuring group-level parameters

A group is a collection of related RIP peers (neighbors). The group name should be a descriptive name for the group. Follow your group, name, and ID naming conventions for consistency and to help when troubleshooting faults.

All parameters configured for a peer group are applied to the group and are inherited by each peer (neighbor), but a group parameter can be overridden on a specific neighbor-level basis.

The following example displays a group configuration:

### Example:

```
config>router# rip
config>router>rip# group headquarters
config>router>rip>group$ description "Base HQ"
config>router>rip>group# no shutdown
```

```
ALA-A>config>router>rip# info
-----
authentication-type simple
authentication-key "acl865lvz1d" hash
timers 300 600 600
group "headquarters"
description "Base HQ"
exit
```

```
-----
ALA-A>config>router>rip#
```

### 7.8.3 Configuring neighbor-level parameters

After you create a group name and assign options, add neighbor interfaces within the same group. All parameters configured for the peer group level are applied to each neighbor, but a group parameter can be overridden on a specific neighbor basis.

The following example displays a neighbor configuration:

**Example:**

```
config>router# rip
config>router>rip# group headquarters
config>router>rip>group# neighbor ferguson-274
config>router>rip>group>neighbor$ preference 255
config>router>rip>group>neighbor# send both
config>router>rip>group>neighbor# split-horizon enable
config>router>rip>group>neighbor# message-size 255
```

```
ALU-A>config>router>rip>group>neighbor# info
-----
```

```
message-size 255
preference 255
split-horizon enable
no timers
-----
```

```
ALU-A>config>router>rip>group>neighbor#
```

## 7.9 RIP configuration management tasks

Examples are provided for the following RIP configuration management tasks:

- [Modifying RIP parameters](#)
- [Deleting a RIP group](#)
- [Deleting a RIP neighbor](#)

### 7.9.1 Modifying RIP parameters

When RIP parameters are modified, added, or removed, the changes are applied immediately. For the complete list of CLI commands, see [Configuring RIP parameters](#).

**CLI syntax:**

```
config>router# rip
group group-name
. . .
neighbor ip-int-name
. . .
```

**Example:**

```
config>router>rip# group "headquarters"
```

```
config>router>rip>group# neighbor "ferguson-274"
config>router>rip>group>neighbor# import RIPpolicy
config>router>rip>group>neighbor# message-size 150
```

The following example displays the updated parameters:

```
ALU-A>config>router>rip# info
-----
authentication-type simple
authentication-key "ac1865lvz1d" hash
timers 300 600 600
group "headquarters"
description "Mt. View"
neighbor "ferguson-274"
import "RIPpolicy"
message-size 150
preference 255
split-horizon enable
no timers
exit
exit
-----
ALU-A>config>router>rip#
```

## 7.9.2 Deleting a RIP group

A RIP group must be shut down first in order to delete it.

Use the following CLI syntax to shut down and then delete a RIP group.

### CLI syntax:

```
config>router# rip
group group-name
shutdown
exit
no group group-name
```

### Example:

```
config>router> rip
config>router>rip# group "RIP-ALU-3"
config>router>rip>group# shutdown
config>router>rip>group# exit
config>router>rip# no group "RIP-ALU-3"
```

If you try to delete the group without shutting it down first, the following message appears:

```
INFO: RIP #1204 group should be administratively down -
virtual router index 1,group
RIP-ALA-4
```

## 7.9.3 Deleting a RIP neighbor

A RIP neighbor must be shut down first in order to delete it.

Use the following CLI syntax to shut down and then delete a RIP neighbor.

**CLI syntax:**

```
config>router# rip
  group group-name
    neighbor ip-int-name
      shutdown
    exit
  no neighbor ip-int-name
```

**Example:**

```
config>router# rip
config>router>rip# group "RIP-ALU-4"
config>router>rip>group# neighbor "to-ALU-3"
config>router>rip>group>neighbor# shutdown
config>router>rip>group>neighbor# exit
config>router>rip>group# no neighbor "to-ALU-3"
```

If you try to delete the neighbor before it is shut down, the following message appears:

```
INFO: RIP #1101 neighbor should be administratively down - virtual router index
```

## 7.10 RIP command reference

### 7.10.1 Command hierarchies

- [Configuration commands](#)
  - [Global RIP commands](#)
  - [Group RIP commands](#)
  - [Neighbor RIP commands](#)
- [Show commands](#)
- [Clear commands](#)
- [Monitor commands](#)
- [Debug commands](#)

#### 7.10.1.1 Configuration commands

##### 7.10.1.1.1 Global RIP commands

```

config
- router [router-name]
  - [no] rip
    - authentication-key {authentication-key | hash-key} [hash | hash2]
    - no authentication-key
    - authentication-type {none | password | message-digest | message-digest-20}
    - no authentication-type
    - check-zero {enable | disable}
    - no check-zero
    - description string
    - no description
    - export policy-name [policy-name...(up to 5 max)]
    - no export
    - export-limit number [log percentage]
    - no export-limit
    - [no] group group-name
    - import policy-name [policy-name...(up to 5 max)]
    - no import
    - message-size max-num-of-routes
    - no message-size
    - metric-in metric
    - no metric-in
    - metric-out metric
    - no metric-out
    - preference preference
    - no preference
    - receive receive-type
    - no receive
    - send send-type
    - no send
    - [no] shutdown
    - split-horizon {enable | disable}

```

- no **split-horizon**
- **timers** *update timeout flush*
- no **timers**

### 7.10.1.1.2 Group RIP commands

```

config
- router [router-name]
  - [no] rip
    - [no] group group-name
      - authentication-key {authentication-key | hash-key} [hash | hash2]
      - no authentication-key
      - authentication-type {none | password | message-digest |
message-digest-20}
      - no authentication-type
      - check-zero {enable | disable}
      - no check-zero
      - description string
      - no description
      - export policy-name [policy-name...(up to 5 max)]
      - no export
      - import policy-name [policy-name...(up to 5 max)]
      - no import
      - message-size max-num-of-routes
      - no message-size
      - metric-in metric
      - no metric-in
      - metric-out metric
      - no metric-out
      - [no] neighbor ip-int-name
      - preference preference
      - no preference
      - receive receive-type
      - no receive
      - send send-type
      - no send
      - [no] shutdown
      - split-horizon {enable | disable}
      - no split-horizon
      - timers update timeout flush
      - no timers

```

### 7.10.1.1.3 Neighbor RIP commands

```

config
- router [router-name]
  - [no] rip
    - [no] group group-name
      - [no] neighbor ip-int-name
        - authentication-key {authentication-key | hash-key} [hash | hash2]
        - no authentication-key
        - authentication-type {none | password | message-digest |
message-digest-20}
        - no authentication-type
        - check-zero {enable | disable}
        - no check-zero
        - description string
        - no description

```



```

- export policy-name [policy-name...(up to 5 max)]
- no export
- import policy-name [policy-name...(up to 5 max)]
- no import
- message-size max-num-of-routes
- no message-size
- metric-in metric
- no metric-in
- metric-out metric
- no metric-out
- preference preference
- no preference
- receive receive-type
- no receive
- send send-type
- no send
- [no] shutdown
- split-horizon {enable | disable}
- no split-horizon
- timers update timeout flush
- no timers

```

### 7.10.1.2 Show commands

```

show
- router [router-instance]
  - rip
    - database [ip-prefix [/mask] [longer] [peer ip-address] [detail]]
    - group [name] [detail]
    - neighbor [ip-int-name | ip-address] [detail] [advertised-routes]
    - peer [interface-name]
    - statistics [ip-int-name | ip-address]

```

### 7.10.1.3 Clear commands

```

clear
- router
  - rip
    - database
    - statistics [neighbor ip-int-name | ip-address]

```

### 7.10.1.4 Monitor commands

```

monitor
- router
  - rip
    - neighbor neighbor [neighbor...(up to 5 max)] [interval seconds] [repeat repeat]
    [absolute | rate]

```

### 7.10.1.5 Debug commands

```

debug

```

```
- router
  - rip
    - [no] auth [neighbor ip-int-name | ip-address]
    - [no] error [neighbor ip-int-name | ip-address]
    - [no] events [neighbor ip-int-name | ip-address]
    - [no] holddown [neighbor ip-int-name | ip-address]
    - [no] packets [neighbor ip-int-name | ip-address]
    - [no] request [neighbor ip-int-name | ip-address]
    - [no] trigger [neighbor ip-int-name | ip-address]
    - [no] updates [neighbor ip-int-name | ip-address]
```



**Note:** Unless specified otherwise, all hierarchical RIP commands can be modified on different levels. The most specific value is used. A RIP group-specific command takes precedence over a global RIP command. A neighbor-specific command takes precedence over a global RIP or group-specific RIP command.

## 7.10.2 Command descriptions

- [Configuration commands](#)
- [Show commands](#)
- [Clear commands](#)
- [Monitor commands](#)
- [Debug commands](#)

### 7.10.2.1 Configuration commands

- [Generic commands](#)
- [RIP commands](#)

#### 7.10.2.1.1 Generic commands

##### description

##### Syntax

**description** *description-string*

**no description**

##### Context

config>router>rip

config>router>rip>group

config>router>rip>group>neighbor

##### Description

This command creates a text description stored in the configuration file for a configuration context.

The **no** form of the command removes the description string from the context.

##### Default

no description is associated with the configuration context

##### Parameters

*description-string*

the description character string. Allowed values are any string up to 80 characters long composed of printable, 7-bit ASCII characters. If the string contains special characters (such as #, \$, or spaces), the entire string must be enclosed within double quotes.

## shutdown

### Syntax

[no] shutdown

### Context

config>router>rip

config>router>rip>group

config>router>rip>group>neighbor

### Description

This command administratively disables an entity. When disabled, an entity does not change, reset, or remove any configuration settings or statistics.

The operational state of the entity is disabled as well as the operational state of any entities contained within. Many objects must be shut down before they may be deleted.

The **no** form of this command administratively enables an entity.

Unlike other commands and parameters where the default state is not indicated in the configuration file, the **shutdown** and **no shutdown** states are always indicated in system-generated configuration files.

Default administrative states for services and service entities are described below in Special Cases.

### Special cases

#### RIP global

the RIP protocol is created in the **no shutdown** state

#### RIP group

RIP groups are created in the **no shutdown** state

#### RIP neighbor

RIP neighbors/peers are created in the **no shutdown** state

## 7.10.2.1.2 RIP commands

## rip

### Syntax

[no] rip

### Context

config>router

## Description

This command creates the RIP protocol instance and RIP configuration context. RIP is administratively enabled upon creation. To start or suspend execution of the RIP protocol without affecting the configuration, use the **[no] shutdown** command.

The **no** form of the command deletes the RIP protocol instance and removes all configuration parameters for the RIP instance.

## Default

no rip

## authentication-key

## Syntax

**authentication-key** {*authentication-key* | *hash-key*} [**hash** | **hash2**]

**no authentication-key**

## Context

config>router>rip

config>router>rip>group

config>router>rip>group>neighbor

## Description

This command configures the RIPv2 authentication key.

Authentication is performed between neighboring routers before setting up the RIP session by verifying the password. Authentication is performed using the MD5 message-based digest.

The authentication key can be any combination of ASCII characters up to 255 characters long. The hash-key can be any combination of ASCII characters up to 342 characters long.

The **no** form of the command removes the authentication password from the configuration and disables authentication.

## Default

no authentication-key

## Parameters

*authentication-key*

the authentication key. The key can be any combination of ASCII characters up to 255 characters in length (unencrypted). If spaces are used in the string, the entire string must be enclosed in quotation marks (" ").

*hash-key*

the hash key. The key can be any combination of ASCII characters up to 342 characters in length (encrypted). If spaces are used in the string, the entire string must be enclosed in quotation marks (" "). This is useful when a user must configure the parameter, but for security purposes, the actual unencrypted key value is not provided.

**hash**

specifies that the key is entered in an encrypted form. If the **hash** parameter is not used, the key is assumed to be in a non-encrypted, clear text form. For security, all keys are stored in encrypted form in the configuration file with the **hash** parameter specified.

**hash2**

specifies that the key is entered in a more complex encrypted form. If the **hash2** parameter is not used, the less-encrypted **hash** form is assumed.

## authentication-type

**Syntax**

**authentication-type** {**none** | **password** | **message-digest** | **message-digest-20**}

**no authentication-type**

**Context**

```
config>router>rip
```

```
config>router>rip>group
```

```
config>router>rip>group>neighbor
```

**Description**

This command sets the type of authentication to be used between RIP neighbors. Authentication type can be specified regardless of the configured send and receive parameters, but will only apply to RIPv2 packets.

The type and password must match exactly for the RIP message to be considered authentic and processed.

The **no** form of the command removes the authentication type from the configuration and disables authentication.

**Default**

no authentication-type

**Parameters****none**

explicitly disables authentication at a given level (global, group, neighbor). If the command does not exist in the configuration, the parameter is inherited from a higher level.

**password**

enables simple password (plaintext) authentication. If authentication is enabled and no authentication type is specified in the command, simple password authentication is enabled.

**message-digest**

configures 16-byte message digest for MD5 authentication. If this option is configured, then at least one message-digest key must be configured.

**message-digest-20**

configures 20-byte message digest for MD5 authentication in accordance with RFC 2082, *RIP-2 MD5 Authentication*. If this option is configured, then at least one message-digest key must be configured.

**check-zero****Syntax**

**check-zero** {enable | disable}

**no check-zero**

**Context**

config>router>rip

config>router>rip>group

config>router>rip>group>neighbor

**Description**

This command enables checking for zero values in fields specified to be zero by the RIPv1 and RIPv2 specifications.

The **check-zero enable** command enables checking of the mandatory zero fields in the RIPv1 and RIPv2 specifications and rejecting of non-compliant RIP messages.

The **check-zero disable** command disables this check and allows the receipt of RIP messages even if the mandatory zero fields are non-zero.

The **check-zero** command can be enabled at all three RIP levels. The most specific value is used. If no check-zero value is set (no check-zero), the setting from the less-specific level is inherited by the lower level.

The **no** form of the command disables check-zero on the configuration.

**Default**

disabled at the RIP global level

**Parameters****enable**

configures the router to reject RIP messages that do not have zero in the mandatory fields

**disable**

configures the router to accept RIP messages that do not have zero in the mandatory fields

## export

### Syntax

**export** *policy-name* [*policy-name...*(up to 5 max)]

**no export**

### Context

config>router>rip

config>router>rip>group

config>router>rip>group>neighbor

### Description

This command specifies the export route policy used to determine which routes are advertised to peers. Route policies are configured in the **config>router>policy-options** context. See the section on "Route Policy" in the 7705 SAR Router Configuration Guide.

When multiple policy names are specified, the policies are evaluated in the order in which they are specified. A maximum of five (5) policy names can be configured. The first policy that matches is applied.

When multiple export commands are issued, the last command entered overrides the previous command.

By default, when no export policies are specified, RIP routes are advertised and non-RIP routes are not advertised.

The **no** form of the command removes the policy association with the RIP instance. To remove association of all policies, use the **no export** command without arguments.

### Default

no export

### Parameters

*policy-name*

the route policy name. Allowed values are any string up to 32 characters long composed of printable, 7-bit ASCII characters. If the string contains special characters (such as #, \$, or spaces), the entire string must be enclosed within double quotes.

## export-limit

### Syntax

**export-limit** *number* [**log** *percentage*]

**no export-limit**

### Context

config>router>rip



## Description

This command configures the maximum number of routes (prefixes) that can be exported into RIP from the route table. Export-limit can be configured only on the global level.

The **no** form of the command removes the parameters from the configuration.

## Default

no export-limit

## Parameters

*number*

specifies the maximum number of routes (prefixes) that can be exported into RIP from the route table

**Values** 1 to 4294967295

*percentage*

specifies the percentage of the export-limit at which a warning log message and SNMP notification would be sent

**Values** 1 to 100

## group

## Syntax

[no] **group** *group-name*

## Context

config>router>rip

## Description

This command enables the context for configuring a RIP group of neighbor interfaces.

RIP groups logically associate RIP neighbor interfaces to facilitate a common configuration for RIP interfaces.

The **no** form of the command deletes the RIP neighbor interface group. Deleting the group also removes the RIP configuration from all of the neighbor interfaces currently assigned to the group.

## Parameters

*group-name*

the RIP group name. Allowed values are any string up to 32 characters long composed of printable, 7-bit ASCII characters. If the string contains special characters (such as #, \$, or spaces), the entire string must be enclosed within double quotes.

## import

### Syntax

**import** *policy-name* [*policy-name*...(up to 5 max)]

**no import**

### Context

config>router>rip

config>router>rip>group

config>router>rip>group>neighbor

### Description

This command specifies the import route policy to be used to determine which routes are accepted from peers. Route policies are configured in the **config>router>policy-options** context. See the section on "Route Policy" in the 7705 SAR Router Configuration Guide.

When multiple policy names are specified, the policies are evaluated in the order in which they are specified. A maximum of five (5) policy names can be specified. The first policy that matches is applied.

When multiple **import** commands are issued, the last command entered will override the previous command.

When an import policy is not specified, RIP routes are accepted by default.

The **no** form of the command removes the policy association with the RIP instance. To remove association of all policies, use **no import** without arguments.

### Default

no import

### Parameters

*policy-name*

the route policy name. Allowed values are any string up to 32 characters long composed of printable, 7-bit ASCII characters. If the string contains special characters (such as #, \$, or spaces), the entire string must be enclosed within double quotes.

## message-size

### Syntax

**message-size** *max-num-of-routes*

**no message-size**

### Context

config>router>rip

```
config>router>rip>group
config>router>rip>group>neighbor
```

### Description

This command configures the maximum number of routes per RIP update message.

By default, each update can contain a maximum of 25 route advertisements. This limit is imposed by RIP specifications. RIP can be configured to send as many as 255 routes per update.

The **no** form of the command reverts to the default value.

### Default

25

### Parameters

*max-num-of-routes*

the maximum number of RIP routes per RIP update message, expressed as a decimal integer

**Values** 25 to 255

## metric-in

### Syntax

**metric-in** *metric*

**no metric-in**

### Context

```
config>router>rip
config>router>rip>group
config>router>rip>group>neighbor
```

### Description

This command configures the metric added to routes received from a RIP neighbor. The specified metric value is added to the hop count and shortens the maximum distance of the route.

When applying an export policy to a RIP configuration, the policy overrides the metric values determined through calculations involving the **metric-in** and **metric-out** values.

The **no** form of the command reverts to the default value.

### Default

1

## Parameters

*metric*

the value added to the metric of routes received from a RIP neighbor, expressed as a decimal integer

**Values** 1 to 16

## metric-out

### Syntax

**metric-out** *metric*

**no metric-out**

### Context

config>router>rip

config>router>rip>group

config>router>rip>group>neighbor

### Description

This command configures the metric assigned to routes exported into RIP and advertised to RIP neighbors. The specified metric value is added to the hop count and shortens the maximum distance of the route.

When applying an export policy to a RIP configuration, the policy overrides the metric values determined through calculations involving the **metric-in** and **metric-out** values.

The **no** form of the command reverts to the default value.

### Default

1

## Parameters

*metric*

the value added to the metric for routes exported into RIP and advertised to RIP neighbors, expressed as a decimal integer

**Values** 1 to 16

## neighbor

### Syntax

[no] **neighbor** *ip-int-name*

## Context

```
config>router>rip>group
```

## Description

This command enables the context for configuring a RIP neighbor interface.

By default, interfaces are not activated unless explicitly configured.

The **no** form of the command deletes the RIP interface configuration for this interface. The **shutdown** command in the **config>router>rip>group group-name>neighbor** context can be used to disable an interface without removing the configuration for the interface.

## Default

No RIP interfaces are defined by default.

## Parameters

*ip-int-name*

the IP interface name. Interface names must already be defined under the **config>router>interface** or **config>service>ies>interface** context.

## preference

## Syntax

```
preference preference
```

```
no preference
```

## Context

```
config>router>rip
```

```
config>router>rip>group
```

```
config>router>rip>group>neighbor
```

## Description

This command configures the route preference for routes learned from the configured peers.

The lower the preference, the higher the chance of the route being the active route. The 7705 SAR assigns the highest default preference to RIP routes as compared to routes that are direct, static, or learned via MPLS or OSPF.

## Default

170

## Parameters

*preference*

the route preference, expressed as a decimal integer

**Values** 1 to 255

## receive

### Syntax

**receive** *receive-type*

**no receive**

### Context

config>router>rip

config>router>rip>group

config>router>rip>group>neighbor

### Description

This command configures the type of RIP updates that will be accepted and processed.

If you specify version-2 or both, the RIP instance listens for and accepts packets sent to the broadcast (255.255.255.255) and multicast (224.0.0.9) addresses.

If version-1 is specified, the router only listens for and accepts packets sent to the broadcast address.

The default behavior is to accept and process both RIPv1 and RIPv2 messages.

The **no** form of the command reverts to the default value.

### Default

both

### Parameters

*receive-type*

configures the type of RIP updates that will be accepted and processed

**Values** *receiver-type* values are both, none, version-1, and version-2, where:

both	specifies that RIP updates in either version 1 or version 2 format will be accepted
none	specifies that RIP updates will not be accepted
version-1	specifies that RIP updates in version 1 format only will be accepted
version-2	specifies that RIP updates in version 2 format only will be accepted

## send

### Syntax

**send** *send-type*

**no send**

### Context

config>router>rip

config>router>rip>group

config>router>rip>group>neighbor

### Description

This command specifies the type of RIP messages sent to RIP neighbors.

If broadcast or version-1 is specified, the router only listens for and accepts packets sent to the broadcast address.

The **no** form of the command reverts to the default value.

### Default

broadcast

### Parameters

*send-type*

configures the type of RIP messages that will be sent to RIP neighbors

**Values** *send-type* values are broadcast, multicast, none, and version-1, where:

broadcast	sends RIPv2 formatted messages to the broadcast address
multicast	sends RIPv2 formatted messages to the multicast address
none	does not to send any RIP messages (silent listener)
version-1	sends RIPv1 formatted messages to the broadcast address

## split-horizon

### Syntax

**split-horizon** {**enable** | **disable**}

**no split-horizon**

## Context

```
config>router>rip
config>router>rip>group
config>router>rip>group>neighbor
```

## Description

This command enables the use of split-horizon.

RIP uses split-horizon with poison-reverse to avoid looping routes propagating through the network. Split-horizon with poison reverse means that routes learned from a neighbor through a given interface are advertised in updates out of the same interface but with a metric of 16 (infinity).

The **split-horizon disable** command enables split horizon without poison reverse. With split horizon enabled, the local router does not readvertise routes learned from a neighbor back to the neighbor.

This configuration parameter can be set at three levels: global level (applies to all groups and neighbor interfaces), group level (applies to all neighbor interfaces in the group) or neighbor level (only applies to the specified neighbor interface). The most specific value is used. In particular if no value is set (no split-horizon), the setting from the less specific level is inherited by the lower level.

The **no** form of the command disables split horizon.

## Default

enable

## Parameters

### enable

enables split horizon and poison reverse

### disable

disables poison reverse but leaves split horizon enabled

## timers

## Syntax

```
timers update timeout flush
```

```
no timers
```

## Context

```
config>router>rip
config>router>rip>group
config>router>rip>group>neighbor
```

## Description

This command configures values for the update, timeout, and flush RIP timers.

The RIP update timer determines how often RIP updates are sent.



If the route is not updated by the time the RIP timeout timer expires, the route is declared invalid but is maintained in the RIP database.

The RIP flush timer determines how long a route is maintained in the RIP database after it has been declared invalid. Once the flush timer expires, the route is removed from the RIP database.

The **no** form of the command reverts to the default values.

## Parameters

### *update*

the RIP update timer value, in seconds, expressed as a decimal integer

**Values** 1 to 600

**Default** 30

### *timeout*

the RIP timeout value, in seconds, expressed as a decimal integer

**Values** 1 to 1200

**Default** 180

### *flush*

the RIP flush timer value, in seconds, expressed as a decimal integer

**Values** 1 to 1200

**Default** 120

## 7.10.2.2 Show commands



**Note:** The following command outputs are examples only; actual displays may differ depending on supported functionality and user configuration.

### database

#### Syntax

```
database [ip-prefix [/mask] [longer]] [peer ip-address] [detail]
```

#### Context

```
show>router>rip
```

#### Description

This command displays the routes in the RIP database.

## Parameters

### *ip-prefix*

the IP prefix for the IP match criterion, in dotted-decimal notation

### */mask*

the subnet mask length, expressed as a decimal integer

### **longer**

displays routes matching the ip-prefix/mask and routes with longer masks

### *ip-address*

specifies a targeted RIP peer

### **detail**

displays detailed information about the RIP database entries

## Output

The following output is an example of RIP database information, and [Table 98: RIP database field descriptions](#) describes the fields.

### Output example

```
A:ALU-A# show router rip database
=====
RIP Route Database
=====
Destination      Peer           NextHop        Metric  Tag    TL    Valid
-----
10.0.0.10/32     10.1.7.15     10.0.0.0       2       0      163  No
10.0.0.10/32     10.1.8.14     10.0.0.0       2       0      179  No
10.0.0.14/32     10.1.8.14     10.0.0.0       1       0      179  Yes
10.0.6.0/24      10.1.7.15     10.0.0.0      11      8194   163  No
10.0.6.0/24      10.1.8.14     10.0.0.0      11      8194   179  No
10.0.7.0/24      10.1.7.15     10.0.0.0      11      8194   163  No
10.1.5.0/24      10.1.7.15     10.0.0.0       2       0      151  Yes
10.1.5.0/24      10.1.8.14     10.0.0.0       1       0      167  No
10.100.17.16/30  10.1.7.15     10.0.0.0       2       0      151  No
10.100.17.16/30  10.1.8.14     10.0.0.0       2       0      167  No
-----
No. of Routes: 10
=====
A:ALU-A#
```

Table 98: RIP database field descriptions

Label	Description
Destination	The RIP destination for the route
Peer	The router ID of the peer router
NextHop	The IP address of the next hop
Metric	The hop count to rate the value of different hops

Label	Description
Tag	The value to distinguish between internal routes (learned by RIP) and external routes (learned from other protocols)
TL	Displays how many seconds the specific route will remain in the routing table. When an entry reaches 0, it is removed from the routing table.
Valid	Yes – the route is valid No – the route is not valid

## group

### Syntax

**group** [*name*] [*detail*]

### Context

show>router>rip

### Description

This command displays group information for a RIP peer group. This command can be entered with or without parameters.

When this command is entered without a group name, information for all peer groups is displayed.

When the command is issued with a specific group name, information for that specific peer group is displayed.

The Admin and Oper state fields display the RIP group's operational state. Valid states are:

- Up – RIP global process is configured and running
- Down – RIP global process is administratively shut down and not running
- Disabled – RIP global process is operationally disabled. The process must be restarted by the operator.

### Parameters

*name*

displays information for the RIP group specified

**detail**

displays detailed information

### Output

The following output is an example of RIP group and detailed RIP group information, and [Table 99: RIP group field descriptions](#) describes the fields.

**Output example**

```
A:ALU-A# show router rip group rip-group
=====
RIP Groups
=====
Interface                               Adm   Opr     Send   Recv   Metric
Mode                                     Mode   In
-----
rip-group                               Up    Down    BCast  Both   1
=====
A:ALU-A#
```

```
*A:ALU-2>show>router>rip# group rip-group detail
=====
RIP Group (detail)
=====
Group : "rip_group"
-----
Description      : No Description Available
Admin State      : Up
Oper State       : Down
Send Mode        : Broadcast
Receive Mode     : Both
Metric In        : 1
Metric Out       : 1
Split Horizon    : Enabled
Check Zero       : Disabled
Message Size     : 25
Preference       : 100
Auth. Type       : None
Update Timer     : 30
Timeout Timer    : 180
Flush Timer      : 120
Export Policies  : None
Import Policies  : None
=====
Peer Groups : 1
=====
*A:ALU-2>show>router>rip#
```

*Table 99: RIP group field descriptions*

Label	Description
Group	The RIP group name
Interface	The interface name
Adm	Indicates whether the RIP neighbor interface is administratively up or down
Opr	Indicates whether the RIP neighbor interface is operationally up or down
Send Mode	Bcast – specifies that RIPv2 formatted messages are sent to the broadcast address Mcast – specifies that RIPv2 formatted messages are sent to the multicast address None – specifies that no RIP messages are sent (silent listener)

Label	Description
	RIPv1 – specifies that RIPv1 formatted messages are sent to the broadcast address
Recv Mode	Both – specifies that RIP updates in either version 1 or version 2 format will be accepted None – specifies that RIP updates will not be accepted RIPv1 – specifies that RIP updates in version 1 format only are accepted RIPv2 – specifies that RIP updates in version 2 format only are accepted
Metric In	The metric added to routes received from a RIP neighbor

## neighbor

### Syntax

**neighbor** [*ip-int-name* | *ip-address*] [**detail**] [**advertised-routes**]

### Context

show>router>rip

### Description

This command displays RIP neighbor information. This command can be entered with or without any parameters.

When this command is issued without any parameters, information for all RIP neighbors displays.

### Parameters

*ip-int-name* | *ip-address*

displays information for the specified IP interface

**Values** *ipv4-address*: a.b.c.d (host bits must be 0)

#### **detail**

displays detailed RIP neighbor information

#### **advertised-routes**

displays the routes advertised to RIP neighbors. If no neighbors are specified, then all routes advertised to all neighbors are displayed. If a neighbor is specified, then only routes advertised to that neighbor are displayed.

### Output

The following outputs are examples of RIP neighbor information:

- RIP neighbor (standard and advertised-routes) ([Output example - RIP neighbor \(standard and advertised routes\)](#), [Table 100: RIP neighbor field descriptions](#) )
- RIP neighbor (detailed) ([Output example - RIP neighbor \(detailed\)](#), [Table 101: RIP neighbor \(detailed\) field descriptions](#))

**Output example - RIP neighbor (standard and advertised routes)**

```
A:ALU-A# show router rip neighbor
=====
RIP Neighbors
=====
Interface                Adm   Opr   Primary IP          Send  Recv  Metric
                        Mode  Mode                               Mode  Mode   In
-----
router-2/1                Up    Up    10.0.3.12           None  Both  1
router-2/2                Up    Up    10.0.5.12           BCast Both  1
router-2/3                Up    Up    10.0.6.12           BCast Both  1
router-2/5                Up    Up    10.0.9.12           BCast Both  1
router-2/6                Up    Up    10.0.17.12          None  Both  1
router-2/7                Up    Up    10.0.16.12          None  Both  1
=====
A:ALU-A#
```

Table 100: RIP neighbor field descriptions

Label	Description
Interface	The RIP neighbor name or IP address
Adm	Indicates whether the RIP neighbor interface is administratively up or down
Opr	Indicates whether the RIP neighbor interface is operationally up or down
Primary IP	The primary IP address of the RIP neighbor interface
Send Mode	Bcast – specifies that RIPv2 formatted messages are sent to the broadcast address Mcast – specifies that RIPv2 formatted messages are sent to the multicast address None – specifies that no RIP messages are sent (silent listener) RIPv1 – specifies that RIPv1 formatted messages are sent to the broadcast address
Recv Mode	Both – specifies that RIP updates in either version 1 or version 2 format will be accepted None – specifies that RIP updates will not be accepted RIPv1 – specifies that RIP updates in version 1 format only are accepted

Label	Description
	RIPv2 – specifies that RIP updates in version 2 format only are accepted
Metric In	The metric added to routes received from a RIP neighbor

**Output example - RIP neighbor (detailed)**

```
A:ALU-A# show router rip neighbor detail
=====
RIP Neighbors (Detail)
=====
-----
Neighbor "router-2/7"
-----
Description      : No Description Available
Primary IP       : 10.0.16.12          Group : seven
Admin State      : Up                  Oper State : Up
Send Mode        : None                Receive Mode : Both
Metric In        : 1                   Metric Out : 1
Split Horizon    : Enabled              Check Zero : Disabled
Message Size     : 25                   Preference : 100
Auth. Type       : None                 Update Timer : 3
Timeout Timer    : 6                     Flush Timer : 6
Export Policies:
  Rip2Rip
  direct2Rip
  bgp2Rip
Import Policies:
  None
=====
A:ALU-A#
```

Table 101: RIP neighbor (detailed) field descriptions

Label	Description
Neighbor	The RIP neighbor name or IP address
Description	The RIP neighbor description. No Description Available indicates no description is configured.
Primary IP	The RIP neighbor interface primary IP address
Group	The RIP group name of the neighbor interface
Admin State	Indicates whether the RIP neighbor interface is administratively up or down
Oper State	Indicates whether the RIP neighbor interface is operationally up or down
Send Mode	Bcast – specifies that RIPv2 formatted messages are sent to the broadcast address Mcast – specifies that RIPv2 formatted messages are sent to the multicast address

Label	Description
	None – specifies that no RIP messages are sent (silent listener) RIPv1 – specifies that RIPv1 formatted messages are sent to the broadcast address
Receive Mode	Both – specifies that RIP updates in either version 1 or version 2 format will be accepted\ None – specifies that RIP updates will not be accepted RIPv1 – specifies that RIP updates in version 1 format only are accepted RIPv2 – specifies that RIP updates in version 2 format only are accepted
Metric In	The metric value added to routes received from a RIP neighbor
Metric Out	The value added to routes exported into RIP and advertised to RIP neighbors
Split Horizon	Indicates whether split horizon and poison reverse is Enabled or Disabled for the RIP neighbor
Check Zero	Disabled – the mandatory zero fields in RIP packets are not checked, allowing receipt of RIP messages even if mandatory zero fields are non-zero for the neighbor Enabled – mandatory zero fields in RIP packets are checked and non-compliant RIP messages are rejected
Message Size	The maximum number of routes per RIP update message
Preference	The preference of RIP routes from the neighbor
Auth. Type	Specifies the authentication type
Update Timer	The current setting of the RIP update timer value expressed in seconds
Timeout Timer	The current RIP timeout timer value expressed in seconds
Flush Timer	The number of seconds after a route has been declared invalid that it is flushed from the route database
Export Policies	The export route policy that is used to determine routes advertised to all peers
Import Policies	The import route policy that is used to determine which routes are accepted from RIP neighbors



## peer

### Syntax

```
peer [interface-name]
```

### Context

```
show>router>rip
```

### Description

This command displays RIP peer information.

### Parameters

*interface-name*

displays peer information for peers on the specified IP interface

### Output

The following output is an example of RIP peer information, and [Table 102: RIP peer field descriptions](#) describes the fields.

#### Output example

```

A:ALU-A# show router rip peers
=====
RIP Peers
=====
Peer IP Addr      Interface Name          Version    Last Update
-----
10.0.5.13         router-2/2              RIPv2     0
10.0.6.16         router-2/3              RIPv2     2
10.0.9.14         router-2/5              RIPv2     8
10.0.10.15        router-2/4              RIPv2     0
-----
No. of Peers: 4
=====
A:ALU-A#

```

Table 102: RIP peer field descriptions

Label	Description
Peer IP Addr	The IP address of the peer router
Interface Name	The peer interface name
Version	The version of RIP running on the peer
Last Update	The number of days since the last update
No. of Peers	The number of RIP peers

## statistics

### Syntax

**statistics** [*ip-int-name* | *ip-address*]

### Context

show>router>rip

### Description

This command displays interface level statistics for the RIP protocol.

If no IP address or interface name is specified, then all configured RIP interfaces are displayed.

If an IP address or interface name is specified, then only data about the specified RIP interface is displayed.

### Parameters

*ip-addr* | *ip-int-name*

displays statistics for the specified IP interface

### Output

The following output is an example of RIP statistics information, and [Table 103: RIP statistics field descriptions](#) describes the fields.

#### Output example

```
A:ALU-A# show router rip statistics
=====
RIP Statistics
=====
Learned Routes      : 0           Timed Out Routes : 0
Current Memory     : 120624       Maximum Memory   : 262144
-----
Interface "to-web"
-----
Primary IP         : 10.1.1.3       Update Timer     : 30
Timeout Timer      : 180          Flush Timer      : 120
Counter            Total           Last 5 Min       Last 1 Min
-----
Updates Sent       0               0                0
Triggered Updates  0               0                0
Bad Packets Received 0             0                0
RIPv1 Updates Received 0           0                0
RIPv1 Updates Ignored 0           0                0
RIPv1 Bad Routes    0             0                0
RIPv1 Requests Received 0          0                0
RIPv1 Requests Ignored 0          0                0
RIPv2 Updates Received 0           0                0
RIPv2 Updates Ignored 0           0                0
RIPv2 Bad Routes    0             0                0
RIPv2 Requests Received 0          0                0
RIPv2 Requests Ignored 0          0                0
Authentication Errors 0             0                0
=====
```

A:ALU-A#

Table 103: RIP statistics field descriptions

Label	Description
Learned Routes	The number of RIP learned routes that were exported to RIP neighbors
Timed Out Routes	The number of routes that have timed out
Current Memory	The amount of memory used by the RIP router instance
Maximum Memory	The amount of memory allocated for the RIP router instance
Interface	Displays the name of each interface configured in RIP and its associated RIP statistics
Primary IP	The interface IP address
Update Timer	The current setting of the RIP update timer value expressed in seconds
Timeout Timer	The current RIP timeout timer value expressed in seconds
Flush Timer	The number of seconds before a route that has been declared invalid is removed from the route database
Total	The total number of each corresponding RIP statistic collected
Last 5 Min	The number of each corresponding RIP statistic collected in the last 5 minutes
Last 1 Min	The number of each corresponding RIP statistic that was collected in the last minute
Updates Sent	The total number of RIP updates that have been sent
Triggered Updates	The number of triggered updates that have been sent. Triggered updates are sent before the RIP routing table is sent.
Bad Packets Received	The number of RIP updates received on this interface that were discarded as invalid
RIPv1 Updates Received	The number of RIPv1 updates received
RIPv1 Updates Ignored	The number of RIPv1 updates ignored

Label	Description
RIPv1 Bad Routes	The number of bad RIPv1 routes received from the peer
RIPv1 Requests Received	The number of RIPv1 requests received from other routers
RIPv1 Requests Ignored	The number of times the router ignored a RIPv1 route request from other routers
RIPv2 Updates Received	The number of RIPv2 updates received
RIPv2 Updates Ignored	The number of RIPv2 updates ignored
RIPv2 Bad Routes	The number of bad RIPv2 routes received from the peer
RIPv2 Requests Received	The number of RIPv2 requests received from other routers
RIPv2 Requests Ignored	The number of times the router ignored a RIPv2 route request from other routers
Authentication Errors	The number of authentication errors that occurred while attempting to secure table updates

### 7.10.2.3 Clear commands

#### database

##### Syntax

**database**

##### Context

clear>router>rip

##### Description

This command deletes all routes in the RIP database.

#### statistics

##### Syntax

**statistics** [*neighbor ip-int-name* | *ip-address*]

## Context

clear>router>rip

## Description

This command clears RIP neighbor statistics. You can clear statistics for a specific RIP interface or for all RIP interfaces.

## Default

none

## Parameters

*ip-int-name* | *ip-address*

clears the statistics for the specified RIP interface

## 7.10.2.4 Monitor commands

### neighbor

## Syntax

**neighbor** *neighbor* [*neighbor...(up to 5 max)*] [**interval** *seconds*] [**repeat** *repeat*] [**absolute** | **rate**]

## Context

monitor>router>rip

## Description

This command displays statistical RIP neighbor information at the configured interval until the configured count is reached.

The first screen displays the current statistics related to the specified RIP neighbors. The subsequent statistical information listed for each interval is displayed as a delta to the previous display. When the keyword **rate** is specified, the rate-per-second for each statistic is displayed instead of the delta.

Monitor commands are similar to **show** commands but only statistical information displays. Monitor commands display the selected statistics according to the configured number of times at the interval specified.

## Parameters

*neighbor*

the name of the IP interface or the IP address of the neighbor

**Values** *ip-int-name* | *ip-address*

*seconds*

configures the interval for each display, in seconds

**Values** 3 to 60

**Default** 10

*repeat*

configures how many times the command is repeated

**Values** 1 to 999

**Default** 10

**absolute**

displays raw statistics, without processing. No calculations are performed on the delta or rate statistics.

**rate**

displays rate-per-second for each statistic instead of the delta

## 7.10.2.5 Debug commands

### auth

#### Syntax

[no] auth [neighbor *ip-int-name* | *ip-address*]

#### Context

debug>router>rip

#### Description

This command enables debugging for RIP authentication at either the global level or neighbor level.

#### Parameters

*ip-int-name* | *ip-address*

the interface name or IP address of the neighbor

### error

#### Syntax

[no] error [neighbor *ip-int-name* | *ip-address*]

#### Context

debug>router>rip

## Description

This command enables debugging for RIP errors at either the global level or neighbor level.

## Parameters

*ip-int-name* | *ip-address*

the interface name or IP address of the neighbor

## events

## Syntax

[no] events [neighbor *ip-int-name* | *ip-address*]

## Context

debug>router>rip

## Description

This command enables debugging for RIP events at either the global level or neighbor level.

## Parameters

*ip-int-name* | *ip-address*

the interface name or IP address of the neighbor

## holddown

## Syntax

[no] holddown [neighbor *ip-int-name* | *ip-address*]

## Context

debug>router>rip

## Description

This command enables debugging for RIP hold-downs at either the global level or neighbor level.

## Parameters

*ip-int-name* | *ip-address*

the interface name or IP address of the neighbor

## packets

## Syntax

[no] packets [neighbor *ip-int-name* | *ip-address*]

**Context**

debug>router>rip

**Description**

This command enables debugging for RIP packets at either the global level or neighbor level.

**Parameters**

*ip-int-name* | *ip-address*

the interface name or IP address of the neighbor

**request****Syntax**

[no] request [neighbor *ip-int-name* | *ip-address*]

**Context**

debug>router>rip

**Description**

This command enables debugging for RIP requests at either the global level or neighbor level.

**Parameters**

*ip-int-name* | *ip-address*

the interface name or IP address of the neighbor

**trigger****Syntax**

[no] trigger [neighbor *ip-int-name* | *ip-address*]

**Context**

debug>router>rip

**Description**

This command enables debugging for RIP triggers at either the global level or neighbor level.

**Parameters**

*ip-int-name* | *ip-address*

the interface name or IP address of the neighbor



## updates

### Syntax

[no] updates [neighbor *ip-int-name* | *ip-address*]

### Context

debug>router>rip

### Description

This command enables debugging for RIP updates at either the global level or neighbor level.

### Parameters

*ip-int-name* | *ip-address*

the interface name or IP address of the neighbor

## 8 List of acronyms

Table 104: Acronyms

Acronym	Expansion
2G	second-generation wireless telephone technology
3DES	triple DES (data encryption standard)
3G	third-generation mobile telephone technology
6VPE	IPv6 on virtual private edge router
7705 SAR	7705 Service Aggregation Router
7750 SR	7750 Service Router
8 PSK	eight phase shift keying
16 QAM	16-state quadrature amplitude modulation
32 QAM	32-state quadrature amplitude modulation
64 QAM	64-state quadrature amplitude modulation
128 QAM	128-state quadrature amplitude modulation
256 QAM	256-state quadrature amplitude modulation
ABR	area border router available bit rate
AC	alternating current attachment circuit
ACK	acknowledge
ACL	access control list
ACR	adaptive clock recovery
AD	auto-discovery
ADM	add/drop multiplexer
ADP	automatic discovery protocol
AES	advanced encryption standard
AFI	authority and format identifier

Acronym	Expansion
AIGP	accumulated IGP
AIS	alarm indication signal
ALG	application level gateway
AMP	active multipath
AN	association number
ANSI	American National Standards Institute
Apipe	ATM VLL
APS	automatic protection switching
ARP	address resolution protocol
A/S	active/standby
AS	autonomous system
ASAP	any service, any port
ASBR	autonomous system boundary router
ASM	any-source multicast autonomous system message
ASN	autonomous system number
ATM	asynchronous transfer mode
ATM PVC	ATM permanent virtual circuit
AU	administrative unit
AUG	administrative unit group
B3ZS	bipolar with three-zero substitution
Batt A	battery A
B-bit	beginning bit (first packet of a fragment)
BBE	background block errors
Bc	committed burst size
Be	excess burst size
BECN	backward explicit congestion notification
Bellcore	Bell Communications Research

Acronym	Expansion
BFD	bidirectional forwarding detection
BGP	border gateway protocol
BGP-LS	border gateway protocol link state
BGP-LU	border gateway protocol labeled unicast
BITS	building integrated timing supply
BTCA	best time Transmitter clock algorithm
BMU	<p>broadcast, multicast, and unknown traffic</p> <p>Traffic that is not unicast. Any nature of multipoint traffic:</p> <ul style="list-style-type: none"> <li>• broadcast (that is, all 1s as the destination IP to represent all destinations within the subnet)</li> <li>• multicast (that is, traffic typically identified by the destination address, uses special destination address); for IP, the destination must be 224.0.0.0 to 239.255.255.255</li> <li>• unknown (that is, the destination is typically a valid unicast address but the destination port/interface is not yet known; therefore, traffic needs to be forwarded to all destinations; unknown traffic is treated as broadcast)</li> </ul>
BNM	bandwidth notification message
BOF	boot options file
BoS	bottom of stack
BPDU	bridge protocol data unit
BRAS	Broadband Remote Access Server
BSC	Base Station Controller
BSM	bootstrap message
BSR	bootstrap router
BSTA	Broadband Service Termination Architecture
BTS	base transceiver station
CA	<p>certificate authority</p> <p>connectivity association</p>
CAK	connectivity association key
CAS	channel associated signaling

Acronym	Expansion
CBN	common bonding networks
CBS	committed buffer space
CC	continuity check control channel
CCM	continuity check message
CCTV	closed-circuit television
CE	circuit emulation customer edge
CEM	circuit emulation
CES	circuit emulation services
CESoPSN	circuit emulation services over packet switched network
CFM	connectivity fault management
cHDLC	Cisco high-level data link control protocol
CIDR	classless inter-domain routing
CIR	committed information rate
CKN	connectivity association key name
CLI	command line interface
CLP	cell loss priority
CMP	certificate management protocol
C-multicast	customer multicast
CoS	class of service
CPE	customer premises equipment
Cpipe	circuit emulation (or TDM) VLL
CPM	Control and Processing Module (CPM is used instead of CSM when referring to CSM filtering to align with CLI syntax used with other SR products). CSM management ports are referred to as CPM management ports in the CLI.
CPROTO	C prototype
CPU	central processing unit

Acronym	Expansion
C/R	command/response
CRC	cyclic redundancy check
CRC-32	32-bit cyclic redundancy check
CRL	certificate revocation list
CRON	a time-based scheduling service (from chronos = time)
CRP	candidate RP
CSM	Control and Switching Module
CSNP	complete sequence number PDU
CSPF	constrained shortest path first
C-tag	customer VLAN tag
CV	connection verification customer VLAN (tag)
CW	control word
CWDM	coarse wavelength-division multiplexing
DA/FAN	distribution automation and field area network
DC	direct current
DC-C	DC return - common
DCE	data communications equipment
DC-I	DC return - isolated
DCO	digitally controlled oscillator
DCR	differential clock recovery
DDoS	distributed DoS
DE	discard eligibility
DER	distinguished encoding rules
DES	data encryption standard
DF	do not fragment designated forwarder
DH	Diffie-Hellman

Acronym	Expansion
DHB	decimal, hexadecimal, or binary
DHCP	dynamic host configuration protocol
DHCPv6	dynamic host configuration protocol for IPv6
DIS	designated intermediate system
DLCI	data link connection identifier
DLCMI	data link connection management interface
DM	delay measurement
DNS	domain name server
DNU	do not use
DoS	denial of service
dot1p	IEEE 802.1p bits, in Ethernet or VLAN ingress packet headers, used to map traffic to up to eight forwarding classes
dot1q	IEEE 802.1q encapsulation for Ethernet interfaces
DPD	dead peer detection
DPI	deep packet inspection
DPLL	digital phase locked loop
DR	designated router
DSA	digital signal algorithm
DSCP	differentiated services code point
DSL	digital subscriber line
DSLAM	digital subscriber line access multiplexer
DTE	data termination equipment
DU	downstream unsolicited
DUID	DHCP unique identifier
DUS	do not use for synchronization
DV	delay variation
DVMRP	distance vector multicast routing protocol
e911	enhanced 911 service

Acronym	Expansion
EAP	Extensible Authentication Protocol
EAPOL	EAP over LAN
E-bit	ending bit (last packet of a fragment)
E-BSR	elected BSR
ECMP	equal cost multipath
EE	end entity
EFM	Ethernet in the first mile
EGP	exterior gateway protocol
EIA/TIA-232	Electronic Industries Alliance/Telecommunications Industry Association Standard 232 (also known as <a href="#">RS-232</a> )
EIR	excess information rate
EJBCA	Enterprise Java Beans Certificate Authority
E-LAN	Ethernet local area network
E-Line	Ethernet virtual private line
EL	entropy label
eLER	egress label edge router
ELI	entropy label indicator
E&M	ear and mouth earth and magneto exchange and multiplexer
eMBMS	evolved MBMS
EOP	end of packet
EPC	evolved packet core
EPD	early packet discard
Epipes	Ethernet VLL
EPL	Ethernet private line
EPON	Ethernet Passive Optical Network
EPS	equipment protection switching



Acronym	Expansion
ERO	explicit route object
ES	Ethernet segment errored seconds
ESD	electrostatic discharge
ESI	Ethernet segment identifier
ESMC	Ethernet synchronization message channel
ESN	extended sequence number
ESP	encapsulating security payload
ESPI	encapsulating security payload identifier
ETE	end-to-end
ETH-BN	Ethernet bandwidth notification
ETH-CFM	Ethernet connectivity fault management (IEEE 802.1ag)
EVC	Ethernet virtual connection
EVDO	evolution - data optimized
EVI	EVPN instance
EVPL	Ethernet virtual private link
EVPN	Ethernet virtual private network
EXP bits	experimental bits (currently known as <a href="#">TC</a> )
FC	forwarding class
FCS	frame check sequence
FD	frequency diversity
FDB	forwarding database
FDL	facilities data link
FEAC	far-end alarm and control
FEC	forwarding equivalence class
FECN	forward explicit congestion notification
FeGW	far-end gateway
FEP	front-end processor

Acronym	Expansion
FF	fixed filter
FFD	fast fault detection
FIB	forwarding information base
FIFO	first in, first out
FIPS-140-2	Federal Information Processing Standard publication 140-2
FM	fault management
FNG	fault notification generator
FOM	figure of merit
Fpipe	frame relay VLL
FQDN	fully qualified domain name
FR	frame relay
FRG bit	fragmentation bit
FRR	fast reroute
FTN	FEC-to-NHLFE
FTP	file transfer protocol
FXO	foreign exchange office
FXS	foreign exchange subscriber
GFP	generic framing procedure
GigE	Gigabit Ethernet
GLONASS	Global Navigation Satellite System (Russia)
GNSS	global navigation satellite system (generic)
GPON	Gigabit Passive Optical Network
GPRS	general packet radio service
GPS	Global Positioning System
GRE	generic routing encapsulation
GRT	global routing table
GSM	Global System for Mobile Communications (2G)

Acronym	Expansion
GTP-U	GPRS tunneling protocol user plane
GW	gateway
HA	high availability
HCM	high capacity multiplexing
HDB3	high density bipolar of order 3
HDLC	high-level data link control protocol
HEC	header error control
HMAC	hash message authentication code
Hpipe	HDLC VLL
H-QoS	hierarchical quality of service
HSB	hot standby
HSDPA	high-speed downlink packet access
HSPA	high-speed packet access
H-VPLS	hierarchical virtual private line service
IANA	Internet Assigned Numbers Authority
IBN	isolated bonding networks
ICB	inter-chassis backup
ICK	integrity connection value key
ICMP	Internet control message protocol
ICMPv6	Internet control message protocol for IPv6
ICP	IMA control protocol cells
ICV	integrity connection value
IDS	intrusion detection system
IDU	indoor unit
IED	intelligent end device
IEEE	Institute of Electrical and Electronics Engineers
IEEE 1588v2	Institute of Electrical and Electronics Engineers standard 1588-2008

Acronym	Expansion
IES	Internet enhanced service
IETF	Internet Engineering Task Force
IGMP	Internet group management protocol
IGP	interior gateway protocol
IID	instance ID
IKE	Internet key exchange
iLER	ingress label edge router
ILM	incoming label map
IMA	inverse multiplexing over ATM
IMET-IR	inclusive multicast Ethernet tag—ingress replication
INVARP	inverse address resolution protocol
IOM	input/output module
IP	Internet protocol
IPCP	Internet protocol control protocol
IPIP	IP in IP
Ipipe	IP interworking VLL
I-PMSI	inclusive PMSI
IPoATM	IP over ATM
IPS	intrusion prevention system
IPSec	Internet protocol security
IR	ingress replication
IRB	integrated routing and bridging
ISA	integrated services adapter
ISAKMP	Internet security association and key management protocol
IS-IS	Intermediate System-to-Intermediate System
IS-IS-TE	IS-IS-traffic engineering (extensions)
ISO	International Organization for Standardization

Acronym	Expansion
IW	interworking
JP	join prune
KEK	key encryption key
KG	key group
LB	loopback
lbf-in	pound force inch
LBM	loopback message
LBO	line buildout
LBR	loopback reply
LCP	link control protocol
LDP	label distribution protocol
LER	label edge router
LFA	loop-free alternate
LFIB	label forwarding information base
LIB	label information base
LLDP	link layer discovery protocol
LLDPDU	link layer discovery protocol data unit
LLF	link loss forwarding
LLID	loopback location ID
LM	loss measurement
LMI	local management interface
LOS	line-of-sight loss of signal
LSA	link-state advertisement
LSDB	link-state database
LSP	label switched path link-state PDU (for IS-IS)
LSPA	LSP attributes

Acronym	Expansion
LSR	label switching router link-state request
LSU	link-state update
LT	linktrace
LTE	long term evolution line termination equipment
LTM	linktrace message
LTN	LSP ID to NHLFE
LTR	link trace reply
MA	maintenance association
MAC	media access control
MACsec	media access control security
MA-ID	maintenance association identifier
MBB	make-before-break
MBGP	multicast BGP multiprotocol BGP multiprotocol extensions for BGP
MBMS	multimedia broadcast multicast service
MBS	maximum buffer space maximum burst size media buffer space
MBSP	mobile backhaul service provider
MCAC	multicast connection admission control
MC-APS	multi-chassis automatic protection switching
MC-MLPPP	multiclass multilink point-to-point protocol
MCS	multicast server multi-chassis synchronization
MCT	MPT craft terminal
MD	maintenance domain

Acronym	Expansion
MD5	message digest version 5 (algorithm)
MDA	media dependent adapter
MDDDB	multidrop data bridge
MDL	maintenance data link
MDT	multicast distribution tree
ME	maintenance entity
MED	multi-exit discriminator
MEF	Metro Ethernet Forum
MEG	maintenance entity group
MEG-ID	maintenance entity group identifier
MEN	Metro Ethernet network
MEP	maintenance association endpoint
MFC	multi-field classification
MHD	multi-homed device
MHF	MIP half function
MHN	multi-homed network
MI	member identifier
MIB	management information base
MI-IS-IS	multi-instance IS-IS
MIR	minimum information rate
MKA	MACsec key agreement
MLD	multicast listener discovery
mLDP	multicast LDP
MLPPP	multilink point-to-point protocol
mLSP	multicast LSP
MoFRR	multicast-only fast reroute
MP	merge point multilink protocol

Acronym	Expansion
	multipoint
MP-BGP	multiprotocol border gateway protocol
MPLS	multiprotocol label switching
MPLSCP	multiprotocol label switching control protocol
MPP	MPT protection protocol
MPR	see <a href="#">Wavence</a>
MPR-e	Microwave Packet Radio (standalone mode)
MPT-HC V2/9558HC	Microwave Packet Transport, High Capacity version 2
MPT-HLC	Microwave Packet Transport, High-Capacity Long-Haul Cubic (ANSI)
MPT-HQAM	Microwave Packet Transport, High Capacity (MPT-HC-QAM) or Extended Power (MPT-XP-QAM) with 512/1024 QAM
MPT-MC	Microwave Packet Transport, Medium Capacity
MPT-XP	Microwave Packet Transport, High Capacity (very high power version of MPT-HC V2/9558HC)
MRAI	minimum route advertisement interval
MRRU	maximum received reconstructed unit
MRU	maximum receive unit
MSDP	Multicast Source Discovery Protocol
MSDU	MAC Service Data Unit
MSK	master session key
MSO	multi-system operator
MS-PW	multi-segment pseudowire
MSS	maximum segment size Microwave Service Switch
MTIE	maximum time interval error
MTSO	mobile trunk switching office
MTU	maximum transmission unit multi-tenant unit



Acronym	Expansion
M-VPLS	management virtual private line service
MVPN	multicast VPN
MVR	multicast VPLS registration
MW	microwave
MWA	microwave awareness
N·m	newton meter
NAT	network address translation
NAT-T	network address translation traversal
NBMA	non-broadcast multiple access (network)
ND	neighbor discovery
NE	network element
NET	network entity title
NFM-P	Network Functions Manager - Packet (formerly 5620 SAM)
NGE	network group encryption
NG-MVPN	next generation MVPN
NH	next hop
NHLFE	next hop label forwarding entry
NHOP	next-hop
NLOS	non-line-of-sight
NLPID	network level protocol identifier
NLRI	network layer reachability information
NNHOP	next next-hop
NNI	network-to-network interface
Node B	similar to BTS but used in 3G networks — term is used in UMTS (3G systems) while BTS is used in GSM (2G systems)
NOC	network operations center
NPAT	network port address translation
NRC-F	Network Resource Controller - Flow

Acronym	Expansion
NRC-P	Network Resource Controller - Packet
NRC-T	Network Resource Controller - Transport
NRC-X	Network Resource Controller - Cross Domain
NSAP	network service access point
NSD	Network Services Director
NSP	native service processing Network Services Platform
NSSA	not-so-stubby area
NTP	Network Time Protocol
NTR	network timing reference
OADM	optical add/drop multiplexer
OAM	operations, administration, and maintenance
OAMPDU	OAM protocol data units
OC3	optical carrier level 3
OCSP	online certificate status protocol
ODU	outdoor unit
OIF	outgoing interface
OLT	optical line termination
OMC	optical management console
ONT	optical network terminal
OOB	out-of-band
OPX	off premises extension
ORF	outbound route filtering
OS	operating system
OSI	Open Systems Interconnection (reference model)
OSINLCP	OSI Network Layer Control Protocol
OSPF	open shortest path first
OSPF-TE	OSPF-traffic engineering (extensions)

Acronym	Expansion
OSS	operations support system
OSSP	organization specific slow protocol
OTP	one time password
OWAMP	one-way active measurement protocol
P2MP	point to multipoint
PADI	PPPoE active discovery initiation
PADR	PPPoE active discovery request
PAE	port authentication entities
PSB	path state block
PBO	packet byte offset
PBR	policy-based routing
PBX	private branch exchange
PCAP	packet capture
PCC	path computation client
PCE	path computation element
PCEP	Path Computation Element Communication Protocol
PCM	pulse code modulation
PCP	priority code point
PCR	proprietary clock recovery
PDU	power distribution unit protocol data units
PDV	packet delay variation
PDVT	packet delay variation tolerance
PE	provider edge router
PEAPv0	protected extensible authentication protocol version 0
PEM	privacy enhanced mail
PFoE	power feed over Ethernet
PFS	perfect forward secrecy

Acronym	Expansion
PHB	per-hop behavior
PHP	penultimate hop popping
PHY	physical layer
PIC	prefix independent convergence
PID	protocol ID
PIM SSM	protocol independent multicast—source-specific multicast
PIR	peak information rate
PKCS	public key cryptography standards
PKI	public key infrastructure
PLAR	private line automatic ringdown
PLCP	Physical Layer Convergence Protocol
PLR	point of local repair
PLSP	path LSP
PM	performance monitoring
PMSI	P-multicast service interface
P-multicast	provider multicast
PN	packet number
PoE	power over Ethernet
PoE+	power over Ethernet plus
POH	path overhead
POI	purge originator identification
PoP	point of presence
POS	packet over SONET
PPP	point-to-point protocol
PPPoE	point-to-point protocol over Ethernet
PPS	pulses per second
PRC	primary reference clock

Acronym	Expansion
PRS	primary reference source
PRTC	primary reference time clock
PSE	power sourcing equipment
PSK	pre-shared key
PSN	packet switched network
PSNP	partial sequence number PDU
PTA	PMSI tunnel attribute
PTM	packet transfer mode
PTP	performance transparency protocol Precision Time Protocol
PuTTY	an open-source terminal emulator, serial console, and network file transfer application
PVC	permanent virtual circuit
PVCC	permanent virtual channel connection
PW	pseudowire
PWE	pseudowire emulation
PWE3	pseudowire emulation edge-to-edge
Q.922	ITU-T Q-series Specification 922
QL	quality level
QoS	quality of service
QPSK	quadrature phase shift keying
RADIUS	Remote Authentication Dial In User Service
RAN	radio access network
RBS	robbed bit signaling
RD	route distinguisher
RDI	remote defect indication
RED	random early discard
RESV	reservation

Acronym	Expansion
RIB	routing information base
RIP	routing information protocol
RJ45	registered jack 45
RMON	remote network monitoring
RNC	radio network controller
RP	rendezvous point
RPF RTM	reverse path forwarding RTM
RPS	radio protection switching
RPT	rendezvous-point tree
RR	route reflector
RRO	record route object
RS-232	Recommended Standard 232 (also known as <a href="#">EIA/TIA-232</a> )
RSA	Rivest, Shamir, and Adleman (authors of the RSA encryption algorithm)
RSHG	residential split horizon group
RSTP	rapid spanning tree protocol
RSVP-TE	resource reservation protocol - traffic engineering
RT	receive/transmit
RTC	route target constraint
RTM	routing table manager
RTN	battery return
RTP	real-time protocol
R&TTE	Radio and Telecommunications Terminal Equipment
RTU	remote terminal unit
RU	rack unit
r-VPLS	routed virtual private LAN service
SA	security association source-active

Acronym	Expansion
SAA	service assurance agent
SAFI	subsequent address family identifier
SAK	security association key
SAP	service access point
SAToP	structure-agnostic TDM over packet
SCADA	supervisory control and data acquisition
SC-APS	single-chassis automatic protection switching
SCI	secure channel identifier
SCP	secure copy
SCTP	Stream Control Transmission Protocol
SD	signal degrade space diversity
SDH	synchronous digital hierarchy
SDI	serial data interface
SDN	software defined network
SDP	service destination point
SE	shared explicit
SeGW	secure gateway
SES	severely errored seconds
SETS	synchronous equipment timing source
SF	signal fail
SFP	small form-factor pluggable (transceiver)
SFTP	SSH file transfer protocol
(S,G)	(source, group)
SGT	self-generated traffic
SHA-1	secure hash algorithm
SHG	split horizon group
SIR	sustained information rate

Acronym	Expansion
SL	short length
SLA	service-level agreement
SLARP	serial line address resolution protocol
SLID	subscriber location identifier of a GPON module
SLM	synthetic loss measurement
SNMP	Simple Network Management Protocol
SNPA	subnetwork point of attachment
SNR	signal to noise ratio
SNTP	simple network time protocol
SONET	synchronous optical networking
S-PE	switching provider edge router
SPF	shortest path first
SPI	security parameter index
S-PMSI	selective PMSI
SPT	shortest path tree
SR	Service Router (7750 SR) segment routing
SRLG	shared risk link group
SRP	stateful request parameter
SRRP	subscriber routed redundancy protocol
SR-ISIS	segment routing IS-IS
SR-OSPF	segment routing OSPF
SR-TE	segment routing traffic engineering
SSH	secure shell
SSM	source-specific multicast synchronization status messaging
SSU	system synchronization unit
S-tag	service VLAN tag



Acronym	Expansion
STM	synchronous transport module
STM1	synchronous transport module, level 1
STP	spanning tree protocol
STS	synchronous transport signal
SVC	switched virtual circuit
SVEC	synchronization vector
SYN	synchronize
TACACS+	Terminal Access Controller Access-Control System Plus
TC	traffic class (formerly known as <a href="#">EXP bits</a> )
TCI	tag control information
TCP	transmission control protocol
TDA	transmit diversity antenna
TDEV	time deviation
TDM	time division multiplexing
TE	traffic engineering
TEDB	traffic engineering database
TEID	tunnel endpoint identifier
TEP	tunnel endpoint
TFTP	trivial file transfer protocol
T-LDP	targeted LDP
TLS	transport layer security
TLV	type length value
TM	traffic management
ToD	time of day
ToS	type of service
T-PE	terminating provider edge router
TPID	tag protocol identifier

Acronym	Expansion
TPIF	IEEE C37.94 teleprotection interface
TPMR	two-port MAC relay
TPS	transmission protection switching
TSoP	transparent SDH/SONET over packet
TTL	time to live
TTLS	tunneled transport layer security
TTM	tunnel table manager
TU	tributary unit
TUG	tributary unit group
TWAMP	two-way active measurement protocol
U-APS	unidirectional automatic protection switching
UAS	unavailable seconds
UBR	unspecified bit rate
UDP	user datagram protocol
UFD	unidirectional forwarding detection
UMH	upstream multicast hop
UMTS	Universal Mobile Telecommunications System (3G)
UNI	user-to-network interface
uRPF	unicast reverse path forwarding
V.11	ITU-T V-series Recommendation 11
V.24	ITU-T V-series Recommendation 24
V.35	ITU-T V-series Recommendation 35
VC	virtual circuit
VCB	voice conference bridge
VCC	virtual channel connection
VCCV	virtual circuit connectivity verification
VCI	virtual circuit identifier

Acronym	Expansion
VID	VLAN ID
VLAN	virtual LAN
VLL	virtual leased line
VM	virtual machine
VoIP	voice over IP
Vp	peak voltage
VP	virtual path
VPC	virtual path connection
VPI	virtual path identifier
VPLS	virtual private LAN service
VPN	virtual private network
VPRN	virtual private routed network
VPWS	virtual private wire service
VRF	virtual routing and forwarding table
VRRP	virtual router redundancy protocol
V-SAP	virtual service access point
VSE	vendor-specific extension
VSI	virtual switch instance
VSO	vendor-specific option
VT	virtual trunk virtual tributary
VTG	virtual tributary group
Wavence	formerly 9500 MPR (Microwave Packet Radio)
WCDMA	wideband code division multiple access (transmission protocol used in UMTS networks)
WRED	weighted random early discard
WTR	wait to restore
X.21	ITU-T X-series Recommendation 21

Acronym	Expansion
XOR	exclusive-OR
XRO	exclude route object

## 9 Supported standards and protocols

This chapter lists the 7705 SAR compliance with security and telecom standards, the protocols supported, and proprietary MIBs.

### 9.1 Security standards

FIPS 140-2—Federal Information Processing Standard publication 140-2, Security Requirements for Cryptographic Modules

### 9.2 Telecom standards

ANSI/TIA/EIA-232-C—Interface Between Data Terminal Equipment and Data Circuit-Terminating Equipment Employing Serial Binary Data Interchange

IEEE 802.1AB-2016—IEEE Standard for Local and metropolitan area networks - Station and Media Access Control Connectivity Discovery

IEEE 802.1ad—IEEE Standard for Local and Metropolitan Area Networks—Virtual Bridged Local Area Networks

IEEE Std 802.1AE-2006 Media Access Control (MAC) Security

IEEE Std 802.1AEbw-2013—Media Access Control (MAC) Security Amendment 2: Extended Packet Numbering

IEEE 802.1ag—Service Layer OAM

IEEE 802.1p/q—VLAN Tagging

IEEE 802.1x-2010—IEEE Standard for Local and Metropolitan Area Networks—Port-based Network Access Control

IEEE 802.3—10BaseT

IEEE 802.3ab—1000BaseT

IEEE 802.3ah—Ethernet OAM

IEEE 802.3u—100BaseTX

IEEE 802.3x —Flow Control

IEEE 802.3z—1000BaseSX/LX

IEEE 802.3-2008—Revised base standard

IEEE 802.1AX-2008—Link Aggregation Task Force (transferred from IEEE 802.3ad)

IEEE C37.94-2017—N Times 64 Kilobit Per Second Optical Fiber Interfaces Between Teleprotection and Multiplexer Equipment

ITU-T G.704—Synchronous frame structures used at 1544, 6312, 2048, 8448 and 44 736 kbit/s hierarchical levels

ITU-T G.707—Network node interface for the Synchronous Digital Hierarchy (SDH)

ITU-T G.826—End-to-end error performance parameters and objectives for international, constant bit-rate digital paths and connections

ITU-T G.8032 — Ethernet Ring Protection Switching

ITU-T G.984.1—Gigabit-capable passive optical networks (GPON): general characteristics

ITU-T Y.1564—Ethernet service activation test methodology

ITU-T Y.1731—OAM functions and mechanisms for Ethernet-based networks

## 9.3 Protocol support

### 9.3.1 ATM

AF-PHY-0086.001—Inverse Multiplexing for ATM (IMA)

af-tm-0121.000—Traffic Management Specification Version 4.1, March 1999

GR-1113-CORE—Bellcore, Asynchronous Transfer Mode (ATM) and ATM Adaptation Layer (AAL) Protocols Generic Requirements, Issue 1, July 1994

GR-1248-CORE—Generic Requirements for Operations of ATM Network Elements (NEs). Issue 3 June 1996

ITU-T Recommendation I.432.1—B-ISDN user-network interface - Physical layer specification: General characteristics

ITU-T Recommendation I.610—B-ISDN Operation and Maintenance Principles and Functions version 11/95

RFC 2514—Definitions of Textual Conventions and OBJECT\_IDENTITIES for ATM Management, February 1999

RFC 2515—Definition of Managed Objects for ATM Management, February 1999

RFC 2684—Multiprotocol Encapsulation over ATM Adaptation Layer 5

### 9.3.2 BFD

RFC 7130—Bidirectional Forwarding Detection (BFD) on Link Aggregation Group (LAG) Interfaces

RFC 7881—Seamless Bidirectional Forwarding Detection (S-BFD) for IPv4, IPv6, and MPLS

draft-ietf-bfd-mib-00.txt—Bidirectional Forwarding Detection Management Information Base

draft-ietf-bfd-base-o5.txt—Bidirectional Forwarding Detection

draft-ietf-bfd-v4v6-1hop-06.txt—BFD IPv4 and IPv6 (Single Hop)

draft-ietf-bfd-multihop-06.txt—BFD for Multi-hop Paths

### 9.3.3 BGP

RFC 1397—BGP Default Route Advertisement  
RFC 1997—BGP Communities Attribute  
RFC 2385—Protection of BGP Sessions via the TCP MD5 Signature Option  
RFC 2439—BGP Route Flap Dampening  
RFC 2545—Use of BGP-4 Multiprotocol Extensions for IPv6 Inter-Domain Routing  
RFC 2918—Route Refresh Capability for BGP-4  
RFC 3107—Carrying Label Information in BGP-4  
RFC 3392—Capabilities Advertisement with BGP-4  
RFC 4271—BGP-4 (previously RFC 1771)  
RFC 4360—BGP Extended Communities Attribute  
RFC 4364—BGP/MPLS IP Virtual Private Networks (VPNs) (previously RFC 2574bis BGP/MPLS VPNs)  
RFC 4456—BGP Route Reflection: Alternative to Full-mesh IBGP (previously RFC 1966 and RFC 2796)  
RFC 4486—Subcodes for BGP Cease Notification Message  
RFC 4684—Constrained Route Distribution for Border Gateway Protocol/MultiProtocol Label Switching (BGP/MPLS) Internet Protocol (IP) Virtual Private Networks (VPNs)  
RFC 4724—Graceful Restart Mechanism for BGP - GR Helper  
RFC 4760—Multi-protocol Extensions for BGP (previously RFC 2858)  
RFC 4893—BGP Support for Four-octet AS Number Space  
RFC 4798—Connecting IPv6 Islands over IPv4 MPLS Using IPv6 Provider Edge Routers (6PE)  
RFC 5549—Advertising IPv4 Network Layer Reachability Information with an IPv6 Next Hop  
RFC 6513—Multicast in MPLS/BGP IP VPNs  
RFC 6514—BGP Encodings and Procedures for Multicast in MPLS/BGP IP VPNs  
RFC 7311—The Accumulated IGP Metric Attribute for BGP  
RFC 7606—Revised Error Handling for BGP UPDATE Messages  
draft-ietf-idr-add-paths-04.txt—Advertisement of Multiple Paths in BGP  
draft-ietf-idr-add-paths-guidelines-00.txt—Best Practices for Advertisement of Multiple Paths in BGP

### 9.3.4 DHCP/DHCPv6

RFC 1534—Interoperation between DHCP and BOOTP  
RFC 2131—Dynamic Host Configuration Protocol (REV)  
RFC 2132—DHCP Options and BOOTP Vendor Extensions  
RFC 3046—DHCP Relay Agent Information Option (Option 82)  
RFC 3315—Dynamic Host Configuration Protocol for IPv6  
RFC 3736—Stateless Dynamic Host Configuration Protocol (DHCP) Service for IPv6

### 9.3.5 Differentiated services

RFC 2474—Definition of the DS Field in the IPv4 and IPv6 Headers

RFC 2597—Assured Forwarding PHB Group

RFC 2598—An Expedited Forwarding PHB

RFC 3140—Per-Hop Behavior Identification Codes

### 9.3.6 Digital data network management

V.35

RS-232 (also known as EIA/TIA-232)

X.21

### 9.3.7 ECMP

RFC 2992—Analysis of an Equal-Cost Multi-Path Algorithm

### 9.3.8 Ethernet VPN (EVPN)

RFC 7432—BGP MPLS-Based Ethernet VPN

draft-ietf-bess-evpn-vpls-seamless-integ—(PBB-)EVPN Seamless Integration with (PBB-)VPLS

draft-ietf-bess-evpn-vpws—Virtual Private Wire Service support in Ethernet VPN

draft-ietf-rabadan-bess-evpn-pref-pdf—Preference-based EVPN DF Election

### 9.3.9 Frame relay

ANSI T1.617 Annex D—Signalling Specification For Frame Relay Bearer Service

ITU-T Q.922 Annex A—Digital Subscriber Signalling System No. 1 (DSS1) data link layer - ISDN data link layer specification for frame mode bearer services

FRF.1.2—PVC User-to-Network Interface (UNI) Implementation Agreement

RFC 2427—Multiprotocol Interconnect over Frame Relay

### 9.3.10 GRE

RFC 2784—Generic Routing Encapsulation (GRE)

### 9.3.11 Internet protocol (IP) – version 4

RFC 768—User Datagram Protocol



RFC 791—Internet Protocol  
RFC 792—Internet Control Message Protocol  
RFC 793—Transmission Control Protocol  
RFC 826—Ethernet Address Resolution Protocol  
RFC 854—Telnet Protocol Specification  
RFC 1350—The TFTP Protocol (Rev. 2)  
RFC 1812—Requirements for IPv4 Routers  
RFC 3021—Using 31-Bit Prefixes on IPv4 Point-to-Point Links

### 9.3.12 Internet protocol (IP) – version 6

RFC 2460—Internet Protocol, Version 6 (IPv6) Specification  
RFC 2462—IPv6 Stateless Address Autoconfiguration  
RFC 2464—Transmission of IPv6 Packets over Ethernet Networks  
RFC 3587—IPv6 Global Unicast Address Format  
RFC 3595—Textual Conventions for IPv6 Flow Label  
RFC 4007—IPv6 Scoped Address Architecture  
RFC 4193—Unique Local IPv6 Unicast Addresses  
RFC 4291—IPv6 Addressing Architecture  
RFC 4443—Internet Control Message Protocol (ICMPv6) for the Internet Protocol Version 6 Specification  
RFC 4649—DHCPv6 Relay Agent Remote-ID Option  
RFC 4861—Neighbor Discovery for IP version 6 (IPv6)  
RFC 5095—Deprecation of Type 0 Routing Headers in IPv6  
RFC 5952—A Recommendation for IPv6 Address Text Representation

### 9.3.13 IPSec

ITU-T X.690 (2002)—ASN.1 encoding rules: Specification of Basic Encoding Rules (BER), Canonical Encoding Rules (CER) and Distinguished Encoding Rules (DER)  
PKCS #12 Personal Information Exchange Syntax Standard  
RFC 2315—PKCS #7: Cryptographic Message Syntax  
RFC 2409—The Internet Key Exchange (IKE)  
RFC 2986—PKCS #10: Certification Request Syntax Specification  
RFC 3706—A Traffic-Based Method of Detecting Dead Internet Key Exchange (IKE) Peers  
RFC 3947—Negotiation of NAT-Traversal in the IKE  
RFC 3948—UDP Encapsulation of IPsec ESP Packets  
RFC 4301—Security Architecture for the Internet Protocol  
RFC 4303—IP Encapsulating Security Payload (ESP)

RFC 4210—Internet X.509 Public Key Infrastructure Certificate Management Protocol (CMP)  
RFC 4211—Internet X.509 Public Key Infrastructure Certificate Request Message Format (CRMF)  
RFC 4945—The Internet IP Security PKI Profile of IKEv1/ISAKMP, IKEv2, and PKIX  
RFC 5280—Internet X.509 Public Key Infrastructure Certificate and Certificate Revocation List (CRL) Profile  
RFC 5996—Internet Key Exchange Protocol Version 2 (IKEv2)  
RFC 7383—Internet Key Exchange Protocol Version 2 (IKEv2) Message Fragmentation

### 9.3.14 IS-IS

RFC 1142—OSI IS-IS Intra-domain Routing Protocol (ISO 10589)  
RFC 1195—Use of OSI IS-IS for routing in TCP/IP & dual environments  
RFC 2763—Dynamic Hostname Exchange for IS-IS  
RFC 2966—Domain-wide Prefix Distribution with Two-Level IS-IS  
RFC 2973—IS-IS Mesh Groups  
RFC 3373—Three-Way Handshake for Intermediate System to Intermediate System (IS-IS) Point-to-Point Adjacencies  
RFC 3567—Intermediate System to Intermediate System (IS-IS) Cryptographic Authentication  
RFC 3719—Recommendations for Interoperable Networks using IS-IS  
RFC 3784—Intermediate System to Intermediate System (IS-IS) Extensions for Traffic Engineering (TE)  
RFC 3787—Recommendations for Interoperable IP Networks  
RFC 4205 for Shared Risk Link Group (SRLG) TLV  
RFC 4971—Intermediate System to Intermediate System (IS-IS) Extensions for Advertising Router Information  
RFC 5120—M-ISIS: Multi Topology (MT) Routing in Intermediate System to Intermediate Systems (IS-ISs)  
RFC 5304—IS-IS Cryptographic Authentication  
RFC 5305—IS-IS Extensions for Traffic Engineering  
RFC 5307—IS-IS Extensions in Support of Generalized Multi-Protocol Label Switching (GMPLS)  
RFC 5308—Routing IPv6 with IS-IS  
RFC 5309—Point-to-Point Operation over LAN in Link State Routing Protocols  
RFC 5310—IS-IS Generic Cryptographic Authentication  
RFC 6232—Purge Originator Identification TLV for IS-IS

### 9.3.15 LDP

RFC 5036—LDP Specification  
RFC 5283—LDP Extension for Inter-Area Label Switched Paths  
RFC 5350—IANA Considerations for the IPv4 and IPv6 Router Alert Options

RFC 5443—LDP IGP Synchronization  
RFC 5561—LDP Capabilities  
RFC 6388—Label Distribution Protocol Extensions for Point-to-Multipoint and Multipoint-to-Multipoint Label Switched Paths  
RFC 6512—Using Multipoint LDP When the Backbone Has No Route to the Root  
RFC 6829—Label Switched Path (LSP) Ping for Pseudowire Forwarding Equivalence Classes (FECs) Advertised over IPv6  
RFC 7552—Updates to LDP for IPv6  
draft-ietf-mpls-ldp-ip-pw-capability—Controlling State Advertisements Of Non-negotiated LDP Applications  
draft-ietf-mpls-oam-ipv6-rao—IPv6 Router Alert Option for MPLS OAM  
draft-pdutta-mpls-ldp-adj-capability-00—LDP Adjacency Capabilities  
draft-pdutta-mpls-ldp-v2-00—LDP Version 2  
draft-pdutta-mpls-mldp-up-redundancy-00.txt—Upstream LSR Redundancy for Multi-point LDP Tunnels

### 9.3.16 LDP and IP FRR

RFC 5286—Basic Specification for IP Fast Reroute: Loop-Free Alternates  
RFC 7490—Remote Loop-Free Alternate (LFA) Fast Reroute (FRR)

### 9.3.17 MPLS

RFC 3031—MPLS Architecture  
RFC 3032—MPLS Label Stack Encoding  
RFC 3815—Definitions of Managed Objects for the Multiprotocol Label Switching (MPLS), Label Distribution Protocol (LDP)  
RFC 5440—Path Computation Element (PCE) Communication Protocol (PCEP)  
RFC 6790—The Use of Entropy Labels in MPLS Forwarding  
RFC 8253—PCEPS: Usage of TLS to Provide a Secure Transport for the Path Computation Element Communication Protocol (PCEP)  
RFC 8697—Path Computation Element Communication Protocol (PCEP) Extensions for Establishing Relationships between Sets of Label Switched Paths (LSPs)  
RFC 8745—Path Computation Element Communication Protocol (PCEP) Extensions for Associating Working and Protection Label Switched Paths (LSPs) with Stateful PCE  
RFC 8800—Path Computation Element Communication Protocol (PCEP) Extension for Label Switched Path (LSP) Diversity Constraint Signaling  
draft-dhody-pce-pceps-tls13-02—Updates for PCEPS  
draft-ietf-pce-stateful-pce—PCEP Extensions for Stateful PCE  
draft-ietf-pce-segment-routing—PCEP Extensions for Segment Routing  
draft-alvarez-pce-path-profiles—PCE Path Profiles

### 9.3.18 MPLS – OAM

RFC 6424— Mechanism for Performing Label Switched Path Ping (LSP Ping) over MPLS Tunnels

RFC 8029—Detecting Multi-Protocol Label Switched (MPLS) Data Plane Failures

### 9.3.19 Multicast

RFC 3956—Embedding the Rendezvous Point (RP) Address in an IPv6 Multicast Address

RFC 3973—Protocol Independent Multicast - Dense Mode (PIM-DM): Protocol Specification (Revised)

RFC 4610—Anycast-RP Using Protocol Independent Multicast (PIM), which is similar to RFC 3446—Anycast Rendezvous Point (RP) mechanism using Protocol Independent Multicast (PIM) and Multicast Source Discovery Protocol (MSDP)

RFC 6514—BGP Encodings and Procedures for Multicast in MPLS/IP VPNs

RFC 6826—Multipoint LDP In-Band Signaling for Point-to-Multipoint and Multipoint-to-Multipoint Label Switched Paths

cisco-ipmulticast/pim-autorp-spec—Auto-RP: Automatic discovery of Group-to-RP mappings for IP multicast, which is similar to RFC 5059—Bootstrap Router (BSR) Mechanism for Protocol Independent Multicast (PIM)

draft-ietf-l2vpn-vpls-pim-snooping-07—Protocol Independent Multicast (PIM) over Virtual Private LAN Service (VPLS)

draft-ietf-mboned-msdp-deploy-nn.txt—Multicast Source Discovery Protocol (MSDP) Deployment Scenarios

### 9.3.20 Network management

IANA-IFType-MIB

ITU-T X.721—Information technology- OSI-Structure of Management Information

ITU-T X.734—Information technology- OSI-Systems Management: Event Report Management Function

M.3100/3120—Equipment and Connection Models

RFC 1157—SNMPv1

RFC 1850—OSPF-MIB

RFC 1907—SNMPv2-MIB

RFC 2011—IP-MIB

RFC 2012—TCP-MIB

RFC 2013—UDP-MIB

RFC 2030—Simple Network Time Protocol (SNTP) Version 4 for IPv4, IPv6 and OSI

RFC 2096—IP-FORWARD-MIB

RFC 2138—RADIUS

RFC 2206—RSVP-MIB

RFC 2571—SNMP-FRAMEWORKMIB  
RFC 2572—SNMP-MPD-MIB  
RFC 2573—SNMP-TARGET-&-NOTIFICATION-MIB  
RFC 2574—SNMP-USER-BASED-SMMIB  
RFC 2575—SNMP-VIEW-BASED ACM-MIB  
RFC 2576—SNMP-COMMUNITY-MIB  
RFC 2588—SONET-MIB  
RFC 2665—EtherLike-MIB  
RFC 2819—RMON-MIB  
RFC 2863—IF-MIB  
RFC 2864—INVERTED-STACK-MIB  
RFC 3014—NOTIFICATION-LOG MIB  
RFC 3164—The BSD Syslog Protocol  
RFC 3273—HCRMON-MIB  
RFC 3411—An Architecture for Describing Simple Network Management Protocol (SNMP) Management Frameworks  
RFC 3412—Message Processing and Dispatching for the Simple Network Management Protocol (SNMP)  
RFC 3413—Simple Network Management Protocol (SNMP) Applications  
RFC 3414—User-based Security Model (USM) for version 3 of the Simple Network Management Protocol (SNMPv3)  
RFC 3418—SNMP MIB  
RFC 3954—Cisco Systems NetFlow Services Export Version 9  
RFC 5101—Specification of the IP Flow Information Export (IPFIX) Protocol for the Exchange of IP Traffic Flow Information  
RFC 5102—Information Model for IP Flow Information Export  
draft-ietf-disman-alarm-mib-04.txt  
draft-ietf-mpls-ldp-mib-07.txt  
draft-ietf-ospf-mib-update-04.txt  
draft-ietf-mpls-lsr-mib-06.txt  
draft-ietf-mpls-te-mib-04.txt  
TMF 509/613—Network Connectivity Model

### 9.3.21 OSPF

RFC 1765—OSPF Database Overflow  
RFC 2328—OSPF Version 2  
RFC 2370—Opaque LSA Support  
RFC 2740—OSPF for IPv6

RFC 3101—OSPF NSSA Option  
RFC 3137—OSPF Stub Router Advertisement  
RFC 3509—Alternative Implementations of OSPF Area Border Routers  
RFC 3623—Graceful OSPF Restart (support for Helper mode)  
RFC 3630—Traffic Engineering (TE) Extensions to OSPF  
RFC 4203 for Shared Risk Link Group (SRLG) sub-TLV  
RFC 4577—OSPF as the Provider/Customer Edge Protocol for BGP/MPLS IP Virtual Private Networks (VPNs) (support for basic OSPF at PE-CE links)  
RFC 4915—Multi-Topology (MT) Routing in OSPF  
RFC 4970—Extensions to OSPF for Advertising Optional Router Capabilities  
RFC 5185—OSPF Multi-Area Adjacency

### 9.3.22 OSPFv3

RFC 4552—Authentication/Confidentiality for OSPFv3

### 9.3.23 PPP

RFC 1332—PPP Internet Protocol Control Protocol (IPCP)  
RFC 1570—PPP LCP Extensions  
RFC 1619—PPP over SONET/SDH  
RFC 1661—The Point-to-Point Protocol (PPP)  
RFC 1662—PPP in HDLC-like Framing  
RFC 1989—PPP Link Quality Monitoring  
RFC 1990—The PPP Multilink Protocol (MP)  
RFC 2686—The Multi-Class Extension to Multi-Link PPP

### 9.3.24 Pseudowires

Metro Ethernet Forum—Implementation Agreement for the Emulation of PDH Circuits over Metro Ethernet Networks  
RFC 3550—RTP: A Transport Protocol for Real-Time Applications  
RFC 3985—Pseudo Wire Emulation Edge-to-Edge (PWE3) Architecture  
RFC 4385—Pseudowire Emulation Edge-to-Edge (PWE3) Control Word for Use over an MPLS PSN  
RFC 4446—IANA Allocation for PWE3  
RFC 4447—Pseudowire Setup and Maintenance Using the Label Distribution Protocol (LDP)  
RFC 4448—Encapsulation Methods for Transport of Ethernet over MPLS Networks  
RFC 4553—Structure-Agnostic Time Division Multiplexing (TDM) over Packet (SAToP)

RFC 4717—Encapsulation Methods for Transport of Asynchronous Transfer Mode (ATM) over MPLS Networks

RFC 4618—Encapsulation Methods for Transport of PPP/High-Level Data Link Control (HDLC) over MPLS Networks

RFC 4619—Encapsulation Methods for Transport of Frame Relay over Multiprotocol Label Switching (MPLS) Networks

RFC 4816—Pseudowire Emulation Edge-to-Edge (PWE3) Asynchronous Transfer Mode (ATM) Transparent Cell Transport Service

RFC 5085—Pseudowire Virtual Circuit Connectivity Verification (VCCV): A Control Channel for Pseudowires

RFC 5086—Structure-Aware Time Division Multiplexed (TDM) Circuit Emulation Service over Packet Switched Network (CESoPSN)

draft-ietf-pwe3-redundancy-02.txt—Pseudowire (PW) Redundancy

### 9.3.25 RIP

RFC 1058—Routing Information Protocol

RFC 2453—RIP Version 2

### 9.3.26 RADIUS

RFC 2865—Remote Authentication Dial In User Service

RFC 2866—RADIUS Accounting

### 9.3.27 RSVP-TE and FRR

RFC 2430—A Provider Architecture for DiffServ & TE

RFC 2702—Requirements for Traffic Engineering over MPLS

RFC 2747—RSVP Cryptographic Authentication

RFC 2961—RSVP Refresh Overhead Reduction Extensions

RFC 3097—RSVP Cryptographic Authentication - Updated Message Type Value

RFC 3209—Extensions to RSVP for LSP Tunnels

RFC 3210—Applicability Statement for Extensions to RSVP for LSP Tunnels

RFC 3477—Signalling Unnumbered Links in Resource ReSerVation Protocol - Traffic Engineering (RSVP-TE)

RFC 4090—Fast Reroute Extensions to RSVP-TE for LSP Tunnels

### 9.3.28 Segment routing (SR)

draft-francois-rtgwg-segment-routing-ti-lfa-04—Topology Independent Fast Reroute using Segment Routing

draft-gredler-idr-bgp-ls-segment-routing-ext-03—BGP Link-State extensions for Segment Routing

draft-ietf-isis-segment-routing-extensions-04—IS-IS Extensions for Segment Routing

draft-ietf-mpls-spring-lsp-ping-02—Label Switched Path (LSP) Ping/Trace for Segment Routing Networks Using MPLS Dataplane

draft-ietf-ospf-segment-routing-extensions-04—OSPF Extensions for Segment Routing

draft-ietf-spring-segment-routing-15—Segment Routing Architecture

### 9.3.29 SONET/SDH

GR-253-CORE—SONET Transport Systems: Common Generic Criteria. Issue 3, September 2000

ITU-T Recommendation G.841—Telecommunication Standardization Section of ITU, Types and Characteristics of SDH Networks Protection Architecture, issued in October 1998 and as augmented by Corrigendum1 issued in July 2002

### 9.3.30 SSH

RFC 4253—The Secure Shell (SSH) Transport Layer Protocol

draft-ietf-secsh-architecture.txt—SSH Protocol Architecture

draft-ietf-secsh-userauth.txt—SSH Authentication Protocol

draft-ietf-secsh-connection.txt—SSH Connection Protocol

draft-ietf-secsh-newmodes.txt—SSH Transport Layer Encryption Modes

draft-ietf-secsh-filexfer-13.txt—SSH File Transfer Protocol

### 9.3.31 Synchronization

G.781—Synchronization layer functions, 2001/09/17

G.803—Architecture of transport networks based on the synchronous digital hierarchy (SDH)

G.813—Timing characteristics of SDH equipment slave clocks (SEC)

G.823—The control of jitter and wander within digital networks which are based on the 2048 kbit/s hierarchy, 2003/03/16

G.824—The control of jitter and wander within digital networks which are based on the 1544 kbit/s hierarchy, 2003/03/16

G.8261—Timing and synchronization aspects in packet networks

G.8262—Timing characteristics of synchronous Ethernet equipment slave clock

GR 1244 CORE—Clocks for the Synchronized Network: Common Generic Criteria



IEC/IEEE 61850-9-3—Communication networks and systems for power utility automation - Part 9-3: Precision time protocol profile for power utility automation

IEEE C37.238-2017 - IEEE Standard Profile for Use of IEEE 1588 Precision Time Protocol in Power System Applications

IEEE Std 1588-2008—IEEE Standard for a Precision Clock Synchronization Protocol for Networked Measurement and Control Systems

IEEE Std 1588-2008—IEEE Standard for a Precision Clock Synchronization Protocol for Networked Measurement and Control Systems, Annex E – Transport of PTP over User Datagram Protocol over Internet Protocol Version 6

IEEE Std 1588-2019—IEEE Standard for a Precision Clock Synchronization Protocol for Networked Measurement and Control Systems, Annex J

ITU-T G.8264—Telecommunication Standardization Section of ITU, Distribution of timing information through packet networks, issued 10/2008

ITU-T G.8265.1—Telecommunication Standardization Section of ITU, Precision time protocol telecom profile for frequency synchronization, issued 10/2010

ITU-T G.8275.1—Telecommunication Standardization Section of ITU, Precision time protocol telecom profile for phase/time synchronization with full timing support from the network, issued 07/2014

ITU-T G.8275.2—Telecommunication Standardization Section of ITU, Precision time protocol telecom profile for time/phase synchronization with partial timing support from the network, issued 06/2016

RFC 5905—Network Time Protocol Version 4: Protocol and Algorithms Specification

### 9.3.32 TACACS+

IETF draft-grant-tacacs-02.txt—The TACACS+ Protocol

### 9.3.33 TLS

RFC 5246—The Transport Layer Security (TLS) Protocol Version 1.2

RFC 5922—Domain Certificates in the Session Initiation Protocol (SIP)

RFC 6460—Suite B Profile for Transport Layer Security (TLS)

RFC 8446—The Transport Layer Security (TLS) Protocol Version 1.3

### 9.3.34 TWAMP

RFC 5357—A Two-Way Active Measurement Protocol (TWAMP)

### 9.3.35 VPLS

RFC 4762—Virtual Private LAN Services Using LDP

### 9.3.36 VRRP

RFC 2787—Definitions of Managed Objects for the Virtual Router Redundancy Protocol

RFC 3768 Virtual Router Redundancy Protocol

RFC 5798 Virtual Router Redundancy Protocol Version 3 for IPv4 and IPv6

## 9.4 Proprietary MIBs

TIMETRA-ATM-MIB.mib

TIMETRA-CAPABILITY-7705-V1.mib

TIMETRA-CHASSIS-MIB.mib

TIMETRA-CLEAR-MIB.mib

TIMETRA-FILTER-MIB.mib

TIMETRA-GLOBAL-MIB.mib

TIMETRA-LAG-MIB.mib

TIMETRA-LDP-MIB.mib

TIMETRA-LOG-MIB.mib

TIMETRA-MPLS-MIB.mib

TIMETRA-OAM-TEST-MIB.mib

TIMETRA-PORT-MIB.mib

TIMETRA-PPP-MIB.mib

TIMETRA-QOS-MIB.mib

TIMETRA-ROUTE-POLICY-MIB.mib

TIMETRA-RSVP-MIB.mib

TIMETRA-SAP-MIB.mib

TIMETRA-SDP-MIB.mib

TIMETRA-SECURITY-MIB.mib

TIMETRA-SERV-MIB.mib

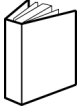
TIMETRA-SYSTEM-MIB.mib

TIMETRA-TC-MIB.mib

TIMETRA-VRRP-MIB.mib



# Customer document and product support



## **Customer documentation**

[Customer documentation welcome page](#)



## **Technical support**

[Product support portal](#)



## **Documentation feedback**

[Customer documentation feedback](#)