



Nokia Service Router Linux

Release 23.3

Advanced Solutions Guide

3HE 19171 AAAA TQZZA
Edition 01
April 2023

© 2023 Nokia.

Use subject to Terms available at: www.nokia.com/terms.

Nokia is committed to diversity and inclusion. We are continuously reviewing our customer documentation and consulting with standards bodies to ensure that terminology is inclusive and aligned with the industry. Our future customer documentation will be updated accordingly.

This document includes Nokia proprietary and confidential information, which may not be distributed or disclosed to any third parties without the prior written consent of Nokia.

This document is intended for use by Nokia's customers ("You"/"Your") in connection with a product purchased or licensed from any company within Nokia Group of Companies. Use this document as agreed. You agree to notify Nokia of any errors you may find in this document; however, should you elect to use this document for any purpose(s) for which it is not intended, You understand and warrant that any determinations You may make or actions You may take will be based upon Your independent judgment and analysis of the content of this document.

Nokia reserves the right to make changes to this document without notice. At all times, the controlling version is the one available on Nokia's site.

No part of this document may be modified.

NO WARRANTY OF ANY KIND, EITHER EXPRESS OR IMPLIED, INCLUDING BUT NOT LIMITED TO ANY WARRANTY OF AVAILABILITY, ACCURACY, RELIABILITY, TITLE, NON-INFRINGEMENT, MERCHANTABILITY OR FITNESS FOR A PARTICULAR PURPOSE, IS MADE IN RELATION TO THE CONTENT OF THIS DOCUMENT. IN NO EVENT WILL NOKIA BE LIABLE FOR ANY DAMAGES, INCLUDING BUT NOT LIMITED TO SPECIAL, DIRECT, INDIRECT, INCIDENTAL OR CONSEQUENTIAL OR ANY LOSSES, SUCH AS BUT NOT LIMITED TO LOSS OF PROFIT, REVENUE, BUSINESS INTERRUPTION, BUSINESS OPPORTUNITY OR DATA THAT MAY ARISE FROM THE USE OF THIS DOCUMENT OR THE INFORMATION IN IT, EVEN IN THE CASE OF ERRORS IN OR OMISSIONS FROM THIS DOCUMENT OR ITS CONTENT.

Copyright and trademark: Nokia is a registered trademark of Nokia Corporation. Other product names mentioned in this document may be trademarks of their respective owners.

The registered trademark Linux® is used pursuant to a sublicense from the Linux Foundation, the exclusive licensee of Linus Torvalds, owner of the mark on a worldwide basis.

© 2023 Nokia.

Table of contents

1	About this guide.....	7
1.1	Precautionary and information messages.....	7
1.2	Conventions.....	7
2	What's new.....	9
3	BGP for underlay routing.....	10
3.1	Applicability.....	10
3.2	BGP underlay routing example.....	10
3.2.1	Advantages of BGP for underlay routing.....	11
3.3	BGP configuration for underlay routing.....	11
3.3.1	Example: Configure Router 3 for static EBGP session.....	11
3.3.2	Example: Configure Router 5 for static EBGP session.....	14
3.4	Advanced configuration: BGP timers.....	17
3.4.1	Modifying timer-related defaults.....	17
3.5	Advanced configuration: BGP convergence optimization.....	18
3.5.1	Configuring wait-for-fib-install.....	19
3.5.2	Convergence process optimization after restarts.....	19
3.5.2.1	Configuring min-wait-to-advertise to delay BGP route advertisement.....	20
3.5.2.2	Configuring max-wait-to-advertise.....	20
3.5.2.3	BGP min-/max-wait-to-advertise timers behavior.....	20
3.5.2.4	Displaying convergence snapshot.....	21
3.6	Advanced configuration: IPv4 route advertisement with IPv6 next-hops.....	22
3.6.1	Advertising a BGP route for IPv4 NLRI with an IPv6 BGP next-hop address.....	22
3.6.2	Receiving a BGP route for IPv4 NLRI with an IPv6 BGP next-hop address.....	23
3.6.3	Accepting IPv4 packets on an IPv6-only interface.....	23
4	MAC-VRF network-instances for server aggregation.....	25
4.1	Applicability.....	25
4.2	Overview.....	25
4.3	Configuration of MAC-VRF network-instances and IRB subinterfaces.....	26
4.3.1	Example: Configure DUT2 with MAC-VRF, IRB, and static BGP on IRB.....	27
4.4	Advanced configuration: bridge-table settings.....	33
4.5	Advanced configuration: MAC-duplication for loop protection.....	33

4.5.1	Example: Configure MAC-duplication and troubleshoot loops in DUT2.....	35
4.5.2	Using logs to detect duplicate MACs.....	37
5	EVPN-VXLAN for layer-2 and multi-homing.....	38
5.1	Applicability.....	38
5.2	Overview.....	38
5.3	Configuration of EVPN-VXLAN broadcast domains.....	39
5.3.1	Configuring the underlay network.....	40
5.3.2	Configuring LEAF-3 with an EVPN-VXLAN enabled MAC-VRF.....	43
5.3.3	Checking the EVPN-VXLAN operation in MAC-VRFs.....	46
5.3.3.1	Checking vxlan-interface configuration.....	46
5.3.3.2	Checking mac-vrf, bgp-vpn, and bgp-evpn parameters.....	47
5.3.3.3	Checking VXLAN tunnels.....	47
5.3.3.4	Checking tunnel-table entries.....	48
5.3.3.5	Checking statistics.....	48
5.3.3.6	Checking for received IMET routes and multicast destination creation.....	49
5.3.3.7	Checking for multicast-destinations.....	52
5.3.3.8	Checking mac-table and MAC/IP routes.....	52
5.3.3.9	Checking unicast destinations.....	53
5.3.4	Checking MAC mobility, MAC protection and MAC loop protection in EVPN-VXLAN BDs.....	54
5.3.4.1	Checking MAC mobility.....	54
5.3.4.2	Checking MAC protection.....	56
5.3.4.3	MAC loop protection.....	58
5.4	Multi-homing configuration for EVPN broadcast domains.....	58
5.4.1	All-active multi-homing configurations.....	59
5.4.1.1	Ethernet segment configuration details.....	60
5.4.2	Configuring LEAF-2 and LEAF-4 as multi-homed nodes to server-1.....	61
5.4.2.1	Use of multi-homing as all-active MLAG for non-EVPN layer-2 BDs.....	65
5.4.3	Checking the multi-homing operation.....	66
5.4.3.1	Checking the ES status.....	66
5.4.3.2	Checking ES and EVI routes.....	67
5.4.3.3	Checking the MAC/IP route.....	69
5.4.3.4	Checking the ES destination.....	70
5.4.3.5	Checking MAC programming.....	71
5.4.3.6	Checking subinterface ES association (LEAF-2).....	71

5.4.3.7	Checking subinterface ES association (LEAF-4).....	72
5.4.3.8	EVPN related logs.....	72
6	EVPN-VXLAN for layer 3.....	73
6.1	Applicability.....	73
6.2	Overview.....	73
6.3	Configuration of EVPN-VXLAN IP-VRF domains.....	74
6.3.1	Preconfiguring the underlay network.....	75
6.3.2	Configuring the LEAF-3 IP-VRF domain.....	75
6.3.3	Configuring the IP-VRF Domain on LEAF-2 and LEAF-4.....	79
6.3.3.1	IRB subinterface considerations.....	88
6.3.4	Configuring EVPN IFL interoperability to EVPN IFF unnumbered model.....	89
6.3.5	Checking the EVPN IFL model in IP-VRFs.....	90
6.3.5.1	Checking IP-VRF-10 state and connectivity.....	90
6.3.5.2	Checking for VXLAN tunnel creation.....	91
6.3.5.3	Checking for remote VTEPS and associated destinations.....	92
6.3.5.4	Checking IP-VRF-10 route table.....	93
6.3.5.5	Checking route-table state for a RT5.....	93
6.3.5.6	Monitoring pings.....	94
6.3.6	Checking PE-CE routing on an IP-VRF with EVPN-IFL.....	96
6.3.6.1	Checking PC-CE routing on IP-VRF.....	97
6.3.6.2	PE-CE EBGP session: import and export policies.....	98
6.3.6.3	Additional PE-CE considerations.....	99
6.3.7	Checking multi-homing in an EVPN-VXLAN Layer 3 network.....	101
6.3.7.1	Consistency check for anycast-gw IPs.....	102
6.3.7.2	Non-anycast-gw IP addresses.....	105
6.3.7.3	Additional anycast gateway considerations.....	107
6.4	Testing and checking Layer 3 host mobility.....	108
6.4.1	Configuring efficient host routing.....	109
6.4.2	Mobility event - efficient host routing.....	112
6.5	EVPN-VXLAN Layer 3 feature parity for IPv6 prefixes.....	117
6.5.1	Configuring IPv6 Container.....	117
6.5.2	Additional feature parity considerations.....	118
7	Security hardening using CPM filters.....	120
7.1	Applicability.....	120

7.2	ACL configuration for control plane protection.....	120
7.2.1	CPM filter rules.....	120
7.2.2	Restricting source subnets for incoming traffic using CPM filter.....	121

1 About this guide

This document describes how to configure advanced solutions for the Nokia Service Router Linux (SR Linux). Advanced solutions are defined as more complex network-level configurations where additional guidance and more detailed procedures may be required.

This document is intended for network technicians, administrators, operators, service providers, and others who need to understand how to use and configure advanced solutions.

This manual covers the current release and may also contain some content that will be released in later maintenance loads. See the *SR Linux Release Notes* for information about features supported in each load.

Configuration and command outputs shown in this guide are examples only; actual displays may differ depending on supported functionality and user configuration.

1.1 Precautionary and information messages

The following are information symbols used in the documentation.



DANGER: Danger warns that the described activity or situation may result in serious personal injury or death. An electric shock hazard could exist. Before you begin work on this equipment, be aware of hazards involving electrical circuitry, be familiar with networking environments, and implement accident prevention procedures.



WARNING: Warning indicates that the described activity or situation may, or will, cause equipment damage, serious performance problems, or loss of data.



Caution: Caution indicates that the described activity or situation may reduce your component or system performance.



Note: Note provides additional operational information.



Tip: Tip provides suggestions for use or best practices.

1.2 Conventions

SR Linux documentation uses the following command conventions.

- **Bold** type indicates a command that the user must enter.
- Input and output examples are displayed in Courier text.
- An open right-angle bracket indicates a progression of menu choices or simple command sequence (often selected from a user interface). Example: **start** > **connect to**.
- A vertical bar (|) indicates a mutually exclusive argument.

-
- Square brackets ([]) indicate optional elements.
 - Braces ({ }) indicate a required choice. When braces are contained within square brackets, they indicate a required choice within an optional element.
 - *Italic* type indicates a variable.

Generic IP addresses are used in examples. Replace these with the IP addresses used in the system.

2 What's new

Topic	Location
Updated output examples to align with changed CLI	Throughout document

3 BGP for underlay routing

A routing protocol is needed to dynamically discover the shortest loop-free path through the underlay of a DC fabric to reach every destination IP subnet. The Border Gateway Protocol (BGP) is one of the leading technologies for this purpose as a result of its simplicity, scalability, and ease of multi-vendor interoperability.

BGP also provides policy mechanisms to perform hop-by-hop traffic engineering, leveraging functionality originally designed for this same purpose in the public Internet.

3.1 Applicability

The information and configuration in this chapter are based on SR Linux Release 19.11.

3.2 BGP underlay routing example

The following figure shows a 3-stage Clos fabric design using only BGP for underlay routing.

Figure 1: BGP underlay routing example

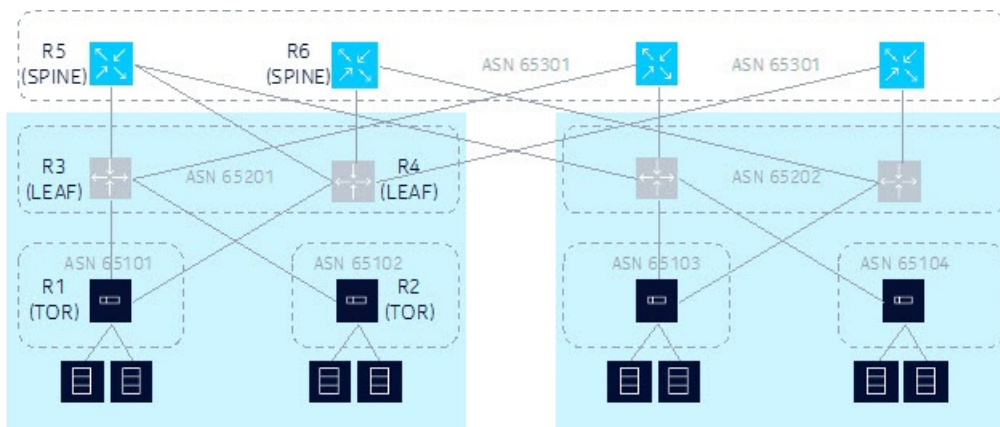

This design example shows the following:

- Each Top-of-Rack (TOR) switch is a BGP router assigned with its own unique Autonomous System Number (ASN).
- Each TOR switch is dual-homed to the two leaf switches in its same POD or container and adding more leaf switches later can achieve scale capacity.
- Each TOR forms one single-hop External Border Gateway Protocol (EBGP) session to each of its upstream leaf switches. From a TOR perspective, these sessions are single-hop because each leaf switch is a BGP neighbor in the same IP subnet as its interface address toward the leaf switch.

- Each leaf switch is a BGP router. All of the leaf switches in one POD or container belong to the same ASN, but this ASN is unique in the data center.
- Each leaf switch has two uplinks into the spine layer. More uplinks could be added later to achieve scale capacity. Each leaf switch forms one single-hop EBGP session with each of its upstream spine switches.
- Each spine switch is a BGP router. All of the spine switches in one data center belong to the same ASN but this ASN is unique in the network.

3.2.1 Advantages of BGP for underlay routing

Using BGP as shown in [Figure 1: BGP underlay routing example](#) has the following advantages:

- Standard operation of the BGP best-path selection algorithm chooses the route to each destination with the AS_PATH length. This equates to the lowest hop count when each device prepends one ASN to the AS_PATH.
- Standard operation of the BGP multipath algorithm sprays traffic across all paths with the same shortest AS_PATH length.
- When a link goes down in the topology, the BGP session is taken down immediately if fast-failover is enabled. This may cause a new BGP best path to be advertised by the routers at each end of the failed session. Other routers may also advertise their own new best paths, but typically the failure does not propagate beyond routers that do not change their best path.
- Traffic can be rerouted around any node in the topology by having it prepend extra AS numbers to the AS_PATH.
- The best path or set of multipaths available to reach a destination TOR are visible in any device by looking at the AS_PATH attribute. This can be helpful with troubleshooting.

3.3 BGP configuration for underlay routing

The following examples define how to bring up a static, preconfigured EBGP session between Router 3 and Router 5 (as shown in [Figure 1: BGP underlay routing example](#)). Use the following two examples to define the minimum configuration required for each router:

- [Example: Configure Router 3 for static EBGP session](#)
- [Example: Configure Router 5 for static EBGP session](#)

3.3.1 Example: Configure Router 3 for static EBGP session

About this task

Use the following example to configure Router 3 for the static EBGP session.

Procedure

Step 1. In candidate mode, create a network-instance that owns the IP subinterface toward Router 5.

Example

```
--{ candidate shared default }--[ network-instance default ]--
```

```
# info detail
  type default
  admin-state enable
  ip-load-balancing {
  }
  interface ethernet-1/1.0 {
  }
  protocols {
  }
```

Ensure the following:

- The network-instance is operationally enabled.
- The subinterface is operationally enabled.
- The subinterface has at least one IPv4 or IPv6 address assigned.

Step 2. Add the BGP protocol to the network-instance.

By default, it is administratively enabled when the configuration is committed.

Example

```
--{ candidate shared default }--[ network-instance default ]--
# protocols bgp
```

Step 3. Assign a global ASN to the BGP instance.

This is the ASN reported to peers when this network-instance opens a BGP session toward another router (unless it is overridden by a local-as configuration).

Router 3 has a global ASN of 65201.

Example

```
--{ candidate shared default }--[ network-instance default protocols bgp ]--
# autonomous-system 65201
```

Step 4. Assign a router-ID to the BGP instance.

This is the BGP identifier reported to peers when this network-instance opens a BGP session toward another router. This overrides the router-id configuration at the network-instance level.

Router 3 has a router-id of 192.0.3.1.

Example

```
--{ candidate shared default }--[ network-instance default protocols bgp ]--
# router-id 192.0.3.1
```

Step 5. Enable all address families that should be enabled globally as a default for all peers of the BGP instance.

When you later configure individual neighbors or groups, you can override the enabled families at those levels.

Example

```
--{ candidate shared default }--[ network-instance default protocols bgp ]--
# afi-safi ipv4-unicast admin-state enable
--{ candidate shared default }--[ network-instance default protocols bgp ]--
# afi-safi ipv6-unicast admin-state enable
```

Step 6. Create a peer group to contain the neighbor session with Router 5.

A peer-group should include sessions that have a similar or almost identical configuration.

In this example, the peer group is named "spine" because it is used to contain all spine layer peers. New groups are administratively enabled by default.

Example

```
--{ candidate shared default}--[ network-instance default protocols bgp ]--
# group spine
```

Step 7. All of the configuration that is common to all peers in the group must be configured at the group level.

In this example, this includes:

- peer-as (of the spine peers)
- export-policy

The export policy (named "pass-all" in the example) in the configuration output below was previously created in this work flow (if it does not exist, the commit fails). The export policy is required to advertise any routes to R5. This is because R5 is an EBGP peer, and by default, no routes are advertised to EBGP peers without an export policy. Note: this can be controlled by a setting in the network-instance protocols "bgp ebgp-default-policy" container.

The "pass-all" export policy matches and accepts all BGP routes, while rejecting all non-BGP routes.

Example

```
--{ candidate shared default}--[ network-
instance default protocols bgp group spine ]
--
# info
  peer-as 65301
  export-policy pass-all
--{ candidate shared }--[ ]
# info from running routing-policy
  routing-policy {
    policy pass-all {
      default-action {
        reject {
        }
      }
    }
    statement 10 {
      match {
        protocol bgp
      }
      action {
        accept
      }
    }
  }
}
```

Step 8. Configure the BGP session with router R5.

In this example, router R5 is reachable to R3 through the ethernet-1/1.0 subinterface. On this subnet, router R5 has the global-unicast IPv6 address 2001:db8::c11.

In this minimal configuration example, the only required configuration for the neighbor is its association with the group "spine" that was previously created. New neighbors are administratively enabled by default.

Example

```
--{ candidate shared default}--[ network-instance default protocols bgp ]--
# neighbor 2001:db8::c11 peer-group spine
```

Step 9. Review all changes and, if everything appears correct, commit the changes:

Example

```
# commit stay
```

3.3.2 Example: Configure Router 5 for static EBGP session

About this task

Use the following example to configure Router 5 for the static EBGP session.

Procedure

Step 1. In candidate mode, create a network-instance that owns the IP subinterface toward Router 3. Ensure that:

- The network-instance is operationally enabled.
- The subinterface is operationally enabled.
- The subinterface has at least one IPv4 or IPv6 address assigned.

Example

```
--{ candidate shared default}--[ network-instance default ]--
# info detail
  type default
  admin-state enable
  ip-forwarding {
    receive-ipv4-check true
    receive-ipv6-check true
  }
  ip-load-balancing {
  }
  interface ethernet-3/1.1 {
  }
  protocols {
  }
  mtu {
    path-mtu-discovery true
  }
```

Step 2. Add the BGP protocol to the network-instance. By default, it is administratively enabled when the configuration is committed.

Example

```
--{ candidate shared default}--[ network-instance default ]--
# protocols bgp
```

- Step 3.** Assign a global autonomous system number to the BGP instance.
Router 5 has a global autonomous system number of 65301.

Example

```
--{ candidate shared default}--[ network-instance default protocols bgp ]--
# autonomous-system 65301
```

- Step 4.** Assign a router-ID to the BGP instance.

This is the BGP identifier reported to peers when this network-instance opens a BGP session toward another router. This overrides the router-ID configuration at the network-instance level.
Router 5 has a router-ID of 192.0.5.1.

Example

```
--{ candidate shared default}--[ network-instance default protocols bgp ]--
# router-id 192.0.5.1
```

- Step 5.** Enable all address families that should be enabled globally as a default for all peers of the BGP instance.

When you later configure individual neighbors or groups, you can override the enabled families at those levels.

Example

```
--{ candidate shared default}--[ network-instance default protocols bgp ]--
# afi-safi ipv4-unicast admin-state enable
--{ candidate shared default}--[ network-instance default protocols bgp ]--
# afi-safi ipv6-unicast admin-state enable
```

- Step 6.** Create a peer-group to contain the neighbor session with Router 3. A peer-group should include sessions that have a similar or almost identical configuration.

In this example, the peer-group is named "leaf-pod1" because it is used to contain all leaf peers in POD1. New groups are administratively enabled by default.

Example

```
--{ candidate shared default}--[ network-instance default protocols bgp ]--
# group leaf-pod1
```

- Step 7.** All of the configuration that is common to all peers in the group must be configured at the group level.

In this example, this includes:

- peer-as (of the leaf peers in POD1)
- export-policy

The export policy (named "pass-all" in the example) is shown in the following running configuration output, and is required to advertise any routes to R3. This is because R3 is an EBGp peer and, by default, no routes are advertised to EBGp peers without an export policy.



Note: This can be controlled by a setting in the network-instance protocols "bgp ebgp-default-policy" container.

The "pass-all" export policy is a simple policy that matches all BGP routes and accepts them, while rejecting all non-BGP routes.

Example

```
--{ candidate Shared default}--[ network-instance default protocols bgp group leaf-
pod1 ]--
# info
  peer-as 65201
  export-policy pass-all
--{ candidate }--[ network-instance default protocols bgp group leaf-pod1 ]--
# exit all
--{ candidate shared default}--[ ]
# info from running routing-policy
  routing-policy {
    policy pass-all {
      default-action {
        reject {
        }
      }
    }
    statement 10 {
      match {
        protocol bgp
      }
      action {
        accept
      }
    }
  }
}
```

Step 8. Configure the BGP session with router R3.

In this example, router R3 is reachable to R5 through the ethernet-3/1.1 subinterface. On this subnet, router R5 has the global-unicast IPv6 address 2001:db8::c12.

In this minimal configuration example, the only required configuration for the neighbor is its association with the group "leaf-pod1" that was previously created. New neighbors are administratively enabled by default.

Example

```
--{ candidate shared default}--[ network-instance default protocols bgp ]--
# neighbor 2001:db8::c12 peer-group leaf-pod1
```

Step 9. Review all changes and if everything looks correct, commit the changes.

Step 10. From Router 3, verify that the session is up (State is established) using the **show neighbor** command under the network-instance protocols BGP hierarchy.

Example

```
--{running}--{ network-instance default protocols bgp }--
srlinux# show neighbor
-----
BGP neighbor summary for network-instance "default"
Flags: S static, D dynamic, L discovered by LLDP, B BFD enabled, - disabled, * slow
-----
+-----+-----+-----+-----+-----+-----+-----+-----+-----+
| Net-Inst | Peer          | Group | Flags | Peer-AS | State       | Uptime   | AFI/SAFI | RX/Active |
|          |               |       |       |         |             |          |           | /TX       |
+-----+-----+-----+-----+-----+-----+-----+-----+-----+
| default  | 2001:db8::cli | spine | S     | 65301   | established | 0d:0h:  | ipv4-unicast | [4/3/1] |
|          |               |       |       |         |             | 34min 7s | ipv6-unicast | [1/1/1] |
+-----+-----+-----+-----+-----+-----+-----+-----+-----+

```



```

+-----+-----+-----+-----+-----+-----+-----+-----+-----+
Summary:
1 configured neighbors, 1 configured sessions are established, 0 disabled peers
None dynamic sessions are established

```

3.4 Advanced configuration: BGP timers

When two BGP routers form a session, they each propose a value for the session hold-time in their OPEN messages. The lowest of the two proposed values becomes the operational hold-time for the lifetime of the session. If the operational hold-time is greater than zero, both routers are agreeing to send keepalive messages to each other. This ensures that any loss of connectivity between them can be detected.

Each router restarts its hold-timer every time it receives a message from the other peer. If the operational hold-timer reaches zero without receiving any keepalive or related message from the peer, the session is torn down (returned to the Idle state). Each router sends a keepalive message to its peer no more than one message every keepalive interval. The default value for the keepalive interval is one third of the operational hold-time, but it possible to configure a different interval.

In a data center environment, an EBGP session failure is usually caused by an interface going down. Interface events are propagated to BGP if fast-failover is enabled. The hold-timer expiry is not the usual mechanism for detecting connectivity problems. However, there may be some circumstances where some adjustment of the hold-time and the keepalive interval can be used.

3.4.1 Modifying timer-related defaults

Procedure

With the SR Linux, the default hold-time is 90 seconds and the default keepalive interval is 30 seconds. To change the hold-time on a session to 24 seconds with a keepalive interval of 8 seconds (1/3 of 24), you only need to change the hold-time value to 24, as shown in the following example:

Example: Change hold-time

```

--{ candidate shared default}--[ network-instance default protocols bgp neighbor
 2001:db8::c11 ]--
# timers hold-time 24

```

After this change is committed, the affected session flaps and the new operational timer values are shown in the output of the **show network-instance protocols bgp neighbor detail** command. For example:

```

srlinux# show network-instance default protocols bgp neighbor 2001:db8::c11 detail
-----
Peer : 2001:db8::c11, remote AS: 65301, local AS: 65201
Type : static
Description : None
Group : spine
Export policies : pass-all
Import policies: pass-all
-----
Admin-state is enable, session-state is established, up for 0d:0h:6m:37s
TCP connection is 2001:db8::c12 [45492] -> 2001:db8::c11 [179]
0 messages in input queue, 0 messages in output queue

```

```

-----
Last-state was active, last-event was rcvOpen, 24 peer-flaps
Last received Notification was Error:Message Header Error SubError: Bad Message Type
Failure detection: BFD is False, fast-failover is False
-----
Graceful Restart
  Restarts by the peer : 0
  Last restart : N/A
  Peer requested restart-time : 300
  Stale routes time : 360
-----
+-----+-----+-----+
|           Timer           | Configured/Operational |       Next       |
+-----+-----+-----+
| connect-retry             | 120                    | -               |
| keepalive-interval       | 30/8                   | -               |
| hold-time                 | 24/24                  | -               |
| minimum-advertisement-interval | 5                      | -               |
+-----+-----+-----+
-----
Cap Sent:  MP_BGP_ROUTE_REFRESH_EXT_NH_ENCODING 4-OCTET_ASN
Cap Recv:  MP_BGP_ROUTE_REFRESH_EXT_NH_ENCODING 4-OCTET_ASN
-----
+-----+-----+-----+
|           Messages        |           Sent          |       Received   |
+-----+-----+-----+
| Non Updates              | 55                     | 52              |
| Updates                  | 424                    | 2               |
| Malformed updates       | 0                      | 0               |
+-----+-----+-----+
-----
Ipv4-unicast AFI/SAFI
  End of RIB                : sent, not received
  Received routes           : 4
  Rejected routes          : None
  Active routes             : 3
  Advertised routes        : 1
  Prefix-Limit              : None
  Default originate        : disabled
  Advertise with IPv6 next-hops : False
  Peer requested GR helper  : None
  Peer preserved forwarding state: None
-----
Ipv6-unicast AFI/SAFI
  End of RIB                : sent, not received
  Received routes           : 1
  Rejected routes          : None
  Active routes             : 1
  Advertised routes        : 1
  Prefix-Limit              : None
  Default originate        : disabled
  Advertise with IPv6 next-hops : N/A
  Peer requested GR helper  : None
  Peer preserved forwarding state: None
-----
--{ candidate shared }--[ ]--

```

3.5 Advanced configuration: BGP convergence optimization

By default, the SR Linux BGP process (running the BGP control plane) does not advertise a route for an IPv4 or IPv6 prefix until it has positive confirmation from the FIB manager process that the route is in the

FIB of all installed line cards. This ensures that the router does not attract traffic destined for an IP prefix until all line cards have the ability to forward the traffic.

**Note:**

The BGP process does not delay route withdrawals until it knows that all line cards have removed the FIB state as this is not needed.

3.5.1 Configuring wait-for-fib-install

Procedure

Nokia recommends that the wait-for-fib-install functionality remain enabled on routers that are in the datapath (that is, routers that set BGP next-hop-self). However, this does cause the rate of RIB-OUT route advertisements to slow to the rate of FIB programming. If the objective of a BGP performance test is to reach the highest possible route advertisement rate, set the wait-for-fib-install configuration leaf to false. For example:

Example: Set wait-for-fib-install leaf to false

```
--{ candidate shared default}--[network-instance default protocols bgp route-  
advertisement]--  
# wait-for-fib-install false
```

3.5.2 Convergence process optimization after restarts

The BGP protocol and its state machine must attempt to reconverge whenever the following occurs:

- the router starts up
- the BGP manager (control plane) application restarts
- all peers of a network-instance are hard-reset by a **tools reset-peer** command

When any of these conditions are met, the router resynchronizes its BGP RIB with the BGP RIB of other routers in the network. When resynchronization completes, BGP has "converged". During convergence, the following occurs to the restarting router:

- It must reestablish its sessions with configured (and discovered) BGP neighbors.
- It must relearn all BGP routes advertised by its direct BGP neighbors (their best paths, plus potentially some additional paths).
- It must advertise to its direct neighbors, its own locally originated BGP routes plus the received routes that it considers its own set of best paths.

The default behavior of SR Linux BGP is to execute all of the preceding steps in parallel. As soon as the first BGP session has reestablished, the restarting router begins to advertise its own best paths to that BGP neighbor (even though it is still in the early stages of rebuilding its RIB-IN database).

As more sessions come up and more routes are learned, it is likely that routes previously considered best are no longer best, leading to multiple route advertisements for the same prefix with each incrementally better than the previous one. The best route is not determined until the last advertisement. The intermediate route advertisements can substantially increase the processing workload on the restarting router as well as its BGP neighbors. This can lengthen the overall convergence time and cause short term inefficiencies in traffic forwarding.

3.5.2.1 Configuring min-wait-to-advertise to delay BGP route advertisement

Procedure

Instead of reconverging as previously described, SR Linux BGP can also be configured to delay the advertisement of BGP routes in a particular address family until convergence has occurred for that address family or until a configured time limit has expired. This behavior is activated by configuring a non-zero value for the min-wait-to-advertise configuration leaf. For example:

Example: Set min-wait-to-advertise

```
--{ candidate shared default }--[ network-  
instance default protocols bgp convergence ]--  
# min-wait-to-advertise 600
```

3.5.2.2 Configuring max-wait-to-advertise

Procedure

The max-wait-to-advertise leaf value for the IPv4-unicast and IPv6-unicast address families can be configured, or you can accept their default values (3x the min-wait-to-advertise value). If configuring a max-wait-to-advertise leaf with a non-default value, the value must be greater than the configured min-wait-to-advertise timer. In the following example, the max-wait-to-advertise timer is set to 900 seconds for IPv4-unicast and set to 800 seconds for IPv6-unicast.

Example: Set max-wait-to-advertise

```
--{ candidate shared default }--[ network-instance default protocols bgp ]--  
# afi-safi ipv4-unicast ipv4-unicast convergence max-wait-to-advertise max-wait-to-  
advertise 900  
# afi-safi ipv6-unicast ipv6-unicast convergence max-wait-to-advertise 800
```

3.5.2.3 BGP min-/max-wait-to-advertise timers behavior

The min-wait-to-advertise timer begins after one of the following triggers occurs and the first BGP session becomes established.

- BGP instance admin state set to enable or disable
- Running **tools clear network-instance protocols bgp reset-peer**
- BGP application restart
- Node reboot

When the first session that supports the exchange of IPv4-unicast routes is established, the max-wait-to-advertise timer of the IPv4 address family starts. Likewise, when the first session that supports the exchange of IPv6-unicast routes is established, the max-wait-to-advertise timer of the IPv6 address family starts.

While the **min-wait-to-advertise** timer is running, BGP sessions come up, and routes are learned and sorted according to preference by the BGP decision process. However, no routes are advertised to any of the peers.

When the min-wait-to-advertise expires, BGP makes a list of IPv4 and IPv6 peers (that is, peers that support the exchange of IPv4-unicast routes and IPv6-unicast routes). It expects to receive the IPv4-unicast End of RIB (EOR) marker from each neighbor in the list of IPv4 peers, and it expects to receive the IPv6-unicast EOR from each neighbor in the list of IPv6 peers.

When BGP in the restarting router receives the last expected IPv4-unicast EOR, it declares that address family as converged and starts to advertise its best IPv4-unicast routes. Likewise, when BGP receives the last expected IPv6-unicast EOR, it declares that address family as converged and starts to advertise its best IPv6-unicast routes.

If the max-wait-to-advertise timer expires before the last expected EOR, is received for an address family, the convergence state for the address family moves to "timeout" and a RIB-OUT advertisement is triggered. This occurs even though convergence is not complete. The max-wait-to-advertise timers are fail-safe. They handle the scenario when one or more peers come up within the min-wait-to-advertise window, but their EORs are not sent.

3.5.2.4 Displaying convergence snapshot

Procedure

In the example that follows, the BGP convergence process is triggered by a hard reset of all peers of the BGP instance:

Example: Trigger BGP convergence using reset-peer

```
--{ * candidate shared default}--[ ]--
dut1# tools network-instance default protocols bgp reset-peer
/network-instance[name=default]/protocols/bgp:
    Successfully executed the tools clear command.
--{ candidate shared }--[ ]--
```

If the **show network-instance protocols bgp summary** command is issued a few minutes after the session restarts, a snapshot of the convergence process can be viewed. For example, in the following output example, ten IPv4-unicast sessions are established when the min-wait-to-advertise timer expires and IPv4-unicast convergence takes 517 seconds.

Example: Display convergence snapshot

```
dut1# show network-instance default protocols bgp summary
-----
BGP is enabled and up in network-instance "default"
Global AS number   : 65201
BGP identifier     : 192.0.3.1
-----
Total paths          : 27
Received routes     : 200000
Received and active routes: 200000
Total UP peers      : 20
Configured peers    : 20, 0 are disabled
Dynamic peers       : None
-----
Default preferences
BGP Local Preference attribute: 100
EBGP route-table preference  : 170
IBGP route-table preference  : 170
-----
Wait for FIB install to advertise: True
Send rapid withdrawals          : False
```

```

-----
Ipv4-unicast AFI/SAFI
  Received routes           : 100000
  Received and active routes : 100000
  Max number of multipaths  : 8, 1
  Multipath can transit multi AS: True
-----
  Min adv delay after restart(slow peer thresh): 600s
  Currently established sessions                  : 10
  Sessions established at slow peer thresh       : 10
  First session establishment after restart      : 5s
  Last session established after restart         : 252s
-----
  Max advertisement delay after first peer UP: 900s
  Max adv delay exceeded after last restart    : None
  Current convergence state                    : converged
  Converged peers                              : 10
  Convergence time after last restart          : 517s
-----
Ipv6-unicast AFI/SAFI
  Received routes           : 100000
  Received and active routes : 100000
  Max number of multipaths  : 1,1
  Multipath can transit multi AS: True
-----
  Min adv delay after restart(slow peer thresh): 600s
  Currently established sessions                  : 10
  Sessions established at slow peer thresh       : 10
  First session establishment after restart      : 8s
  Last session established after restart         : 312s
-----
  Max advertisement delay after first peer UP: 800s
  Max adv delay exceeded after last restart    : None
  Current convergence state                    : converged
  Converged peers                              : 10
  Convergence time after last restart          : 705s
-----
--{ candidate shared }--[ ]--

```

3.6 Advanced configuration: IPv4 route advertisement with IPv6 next-hops

Some data centers are migrating away from an IPv4/IPv6 dual-stack infrastructure and moving toward an IPv6-only infrastructure. In an IPv6-only design, each interface in the fabric (such as the leaf-spine, leaf-TOR) is assigned one or more IPv6 addresses, but no IPv4 addresses.

To route and forward IPv4 packets over an IPv6-only fabric, the leaf and spine switches must support the following:

- The ability to advertise a BGP route for IPv4 Network Level Reachability Information (NLRI) with an IPv6 BGP next-hop address.
- The ability to receive a BGP route for IPv4 NLRI with an IPv6 BGP next-hop address.
- The ability to accept IPv4 packets on an IPv6-only interface.

3.6.1 Advertising a BGP route for IPv4 NLRI with an IPv6 BGP next-hop address

About this task

On the SR Linux, the ability to advertise a BGP route for IPv4 NLRI with an IPv6 BGP next-hop address is not enabled by default.

Procedure

To enable this functionality, use the **advertise-ipv6-next-hops** command, which is available on a per-session basis. The following is a sample configuration:

Example: Advertise BGP route for IPv4 NLRI with IPv6 BGP next-hop

```
--{ candidate shared default }--[ network-instance default protocols bgp ]--  
# afi-safi ipv4-unicast ipv4-unicast advertise-ipv6-next-hops true
```

3.6.2 Receiving a BGP route for IPv4 NLRI with an IPv6 BGP next-hop address

About this task

On the SR Linux, the ability to receive a BGP route for IPv4 NLRI with an IPv6 BGP next-hop address is not enabled by default. To enable this functionality, use the **receive-ipv6-next-hops** command, which is available on a per-session basis.

This command allows SR Linux to advertise the extended-next-hop-encoding BGP capability, defined in RFC 5549, to the peers included in the scope of the command. This BGP capability encodes NLRI AFI 1, NLRI SAFI 1, and next-hop AFI 2. It informs peers that they can advertise MP-BGP encoded IPv4 routes with IPv6 next-hops. When the routes are received, the router then attempts to resolve them using IPv6 routes.

If the router receives an IPv4 route with an IPv6 next-hop that is resolved by a static or direct IPv6 route (and an IPv6 neighbor entry for the next-hop host address), the IPv4 route is programmed in the FIB so that matching IPv4 packets are sent without additional encapsulation. Packets are sent through the indicated interface with a MAC destination address provided by the IPv6 neighbor entry.

Procedure

The following is a configuration example:

Example: Receive BGP route for IPv4 NLRI with IPv6 BGP next-hop

```
--{ candidate shared }--[ network-instance default protocols bgp ]--  
# afi-safi ipv4-unicast ipv4-unicast receive-ipv6-next-hops true
```

3.6.3 Accepting IPv4 packets on an IPv6-only interface

About this task

The datapath of the SR Linux checks for and discards all IPv4 packets that are received on an IPv6-only subinterface (that is, a subinterface with no configured IPv4 addresses). This is done for security reasons. However, if the router has advertised IPv4 routes with IPv6 next-hops to a peer, the check should be disabled on all subinterfaces that could be used by the peer when it installs the IPv4 route.

Procedure

To disable this check on all subinterfaces bound to a specific network-instance, set the **ipv4-receive-check leaf** to **false**.

The following is a configuration example:

Example: Accept IPv4 packets on an IPv6-only interface

```
--{ candidate shared default }--[ network-instance default ]--  
# ip-forwarding receive-ipv4-check false
```

4 MAC-VRF network-instances for server aggregation

MAC-VRF network-instances can provide aggregation for a group of servers into the same subnet. This chapter defines concepts and procedures for configuring MAC-VRF network-instances and Integrated Routing and Bridging (IRB) subinterfaces.

4.1 Applicability

The information and configuration in this chapter are based on SR Linux Release 20.6.

4.2 Overview

Data Center (DC) servers or hosts are connected to TOR routers so that they can be reached from other TOR routers in the same IP fabric. The TOR nodes use BGP to learn and propagate subnet reachability in the underlying routing infrastructure. The servers or hosts connected to these TOR BGP routers use routed subinterfaces on the TOR, and static routes or a PE-CE BGP session, to learn or advertise reachability to the rest of the DC.

Each server requires a separate routed subinterface and subnet on the TOR, and the number of subinterfaces and local routes in the route-table grows linearly as the number of servers increases. The use of a MAC-VRF network-instance provides aggregation for a group of servers into the same subnet. This saves routes and subinterfaces in the TOR. A MAC-VRF is attached to the default network-instance by a single IRB interface and subnet, instead of a separate subinterface and route per server. The following figure shows an example of MAC-VRF network-instances for server aggregation.

Figure 2: MAC-VRF network-instances for server aggregation

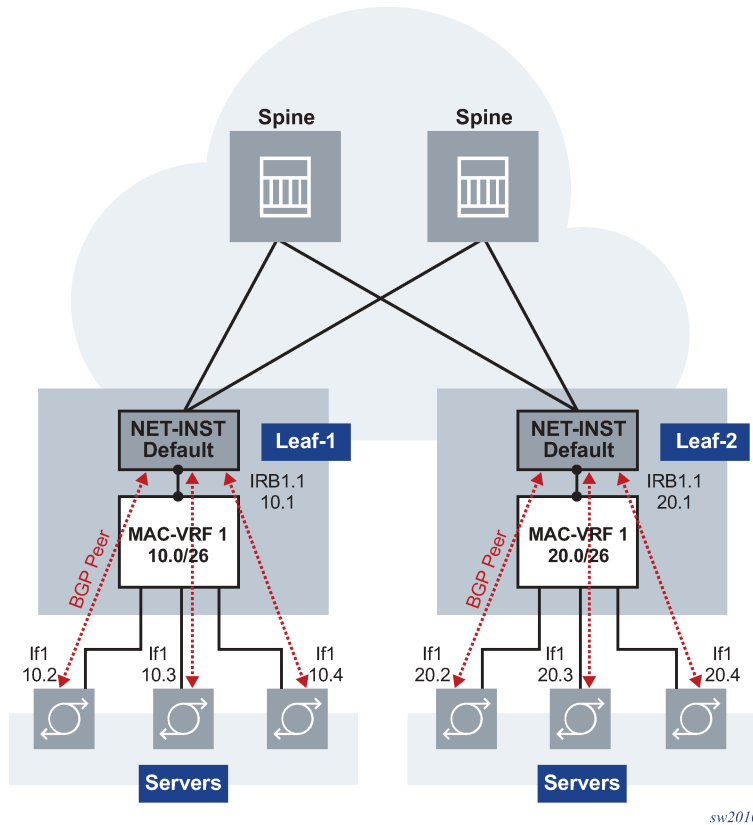

In this example, Leaf-1 and Leaf-2 are configured with MAC-VRF instances that aggregate a group of servers. These servers are assigned IP addresses on the same subnet and are connected to the leaf default network-instance by a single IRB subinterface. The servers use a PE-CE BGP session with the IRB IP address to exchange reachability. The use of the MAC-VRF with an IRB subinterface saves routed subinterfaces on the default network-instance; only one routed subinterface is needed instead of one per server.

4.3 Configuration of MAC-VRF network-instances and IRB subinterfaces

The following figure shows an example of how to configure MAC-VRF network-instances and their IRB subinterfaces to the default network-instance, and how EBGP sessions are configured with the servers. In this example, DUT2 is the TOR being configured. DUT1 and DUT3 are servers that are running BGP against the DUT2 IRB subinterface.

Figure 3: MAC-VRF and IRB example in DUT2

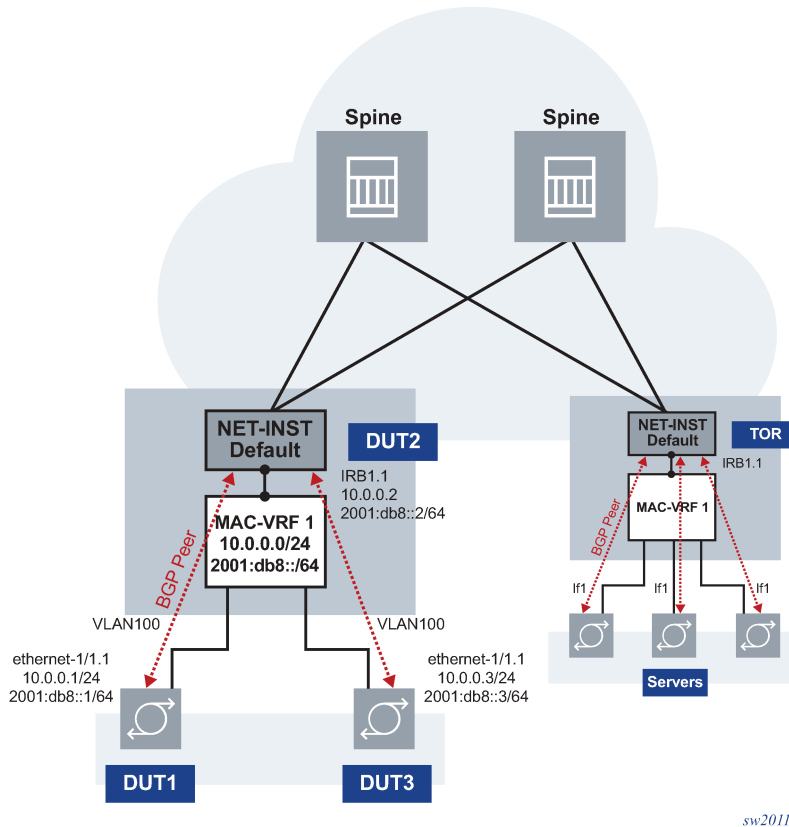

4.3.1 Example: Configure DUT2 with MAC-VRF, IRB, and static BGP on IRB

Prerequisites

This example assumes DUT2 is pre-configured with a default network-instance that runs BGP sessions to the spine routers, as defined in the section: [BGP for underlay routing](#).

About this task

This example shows how to configure the DUT2 with a MAC-VRF, bridged subinterfaces to DUT1 and DUT3, and an IRB subinterface (see [Figure 3: MAC-VRF and IRB example in DUT2](#)).

Procedure

Step 1. In candidate mode, create the interfaces and bridged subinterfaces to connect to DUT1 and DUT3.

In this example:

- Connect ethernet-1/1 and ethernet-1/2 to DUT1 and DUT3, respectively. Although these interfaces could be defined untagged, this example configures them as tagged (vlan-tagging true).

- Create a subinterface with index 1 under each interface. The subinterface must be configured as type bridged. Bridged subinterfaces can be associated with MAC-VRF instances so that MAC learning and layer-2 forwarding can be enabled on them.
- The subinterfaces use vlan-id 100 because this is the VLAN ID used by the servers (DUT1 and DUT2) to send and receive frames.

Example

```
--{ candidate shared default }--[ interface * ]--
A:dut2# info
  interface ethernet-1/1 {
    description dut2-dut1
    vlan-tagging true
    subinterface 1 {
      type bridged
      vlan {
        encap {
          single-tagged {
            vlan-id 100
          }
        }
      }
    }
  }
  interface ethernet-1/2 {
    description dut2-dut3
    vlan-tagging true
    subinterface 1 {
      type bridged
      vlan {
        encap {
          single-tagged {
            vlan-id 100
          }
        }
      }
    }
  }
}
```

- Step 2.** Configure an IRB interface and subinterface to connect the MAC-VRF to the existing default network-instance.

The IRB is configured in a similar way to a loopback interface and subinterfaces. The IRB subinterface must be type routed, but does not need to be explicitly configured as routed.

Example

```
--{ candidate shared default }--[ interface irb* ]--
A:dut2# info
  interface irb1 {
    subinterface 1 {
      ipv4 {
        address 10.0.0.2/24 {
        }
      }
      ipv6 {
        address 2001:db8::2/64 {
        }
      }
    }
  }
}
```

Step 3. Configure the network-instance type mac-vrf and associate it with the bridged and IRB interfaces.

Example

```
--{ candidate shared default }--[ network-instance MAC-VRF-1 ]--
A:dut2# info
  type mac-vrf
  admin-state enable
  interface ethernet-1/1.1 {
  }
  interface ethernet-1/2.1 {
  }
  interface irb1.1 {
  }
```

Step 4. Associate the same IRB interface with the network-instance default and configure the BGP IPv4 and IPv6 neighbors to DUT1 and DUT3.

See [BGP for underlay routing](#) for more information about configuring BGP sessions.

Example

```
--{ candidate shared default }--[ network-instance default ]--
A:dut2# info
  type default
  admin-state enable
  router-id 2.2.2.2
  interface irb1.1 {
  }
  interface lo0.1 {
  }
  protocols {
    bgp {
      admin-state enable
      afi-safi ipv4-unicast {
        admin-state enable
      }
      autonomous-system 64502
      router-id 10.0.0.2
      ebgp-default-policy {
        import-reject-all false
      }
      failure-detection {
        enable-bfd true
        fast-failover true
      }
      group tor {
        admin-state enable
        export-policy pass-all
        afi-safi ipv4-unicast {
          admin-state enable
        }
        afi-safi ipv6-unicast {
          admin-state enable
        }
        local-as as-number 64502 {
        }
        timers {
          minimum-advertisement-interval 1
        }
        trace-options {
          flag update {
          }
          flag graceful-restart {
          }
        }
      }
    }
  }
```

```

    }
    flag events {
    }
    flag keepalive {
    }
    flag notification {
    }
    flag open {
    }
    flag packets {
    }
    flag route {
    }
    flag socket {
    }
    flag timers {
    }
  }
}
afi-safi ipv4-unicast {
  admin-state enable
}
afi-safi ipv6-unicast {
  admin-state enable
}
neighbor 10.0.0.1 {
  peer-as 64501
  peer-group tor
  transport {
    local-address 10.0.0.2
  }
}
neighbor 10.0.0.3 {
  peer-as 64503
  peer-group tor
  transport {
    local-address 10.0.0.2
  }
}
neighbor 2001:db8::1 {
  peer-as 64501
  peer-group tor
  transport {
    local-address 2001:db8::2
  }
}
neighbor 2001:db8::3 {
  peer-as 64503
  peer-group tor
  transport {
    local-address 2001:db8::2
  }
}
}
}
}

```

Step 5. Review all the changes and commit if correct.

Example

```

--{ candidate shared default }--[ ]--
A:dut2# commit stay

```

Step 6. Check the state of the MAC-VRF and the connectivity to DUT1 and DUT3 using the following commands:

- **show network-instance MAC-VRF-1 interfaces**
- **show network-instance default interfaces**
- **show network-instance MAC-VRF-1 bridge-table mac-table all**
- **show arpnd arp-entries interface irb1**
- **show arpnd neighbors interface irb1**
- **show network-instance default protocols bgp neighbor**

Example

```
A:dut2# show network-instance MAC-VRF-1 interfaces
=====
Net instance      : MAC-VRF-1
Interface         : ethernet-1/1.1
Type              : bridged
Oper state        : up
=====
Net instance      : MAC-VRF-1
Interface         : ethernet-1/2.1
Type              : bridged
Oper state        : up
=====
Net instance      : MAC-VRF-1
Interface         : irb1.1
Oper state        : up
Ip mtu            : 1500
Prefix            Origin      Status
=====
10.0.0.2/24      static
2001:db8::2/64   static      preferred
fe80::201:2ff:feff:41/64 link-layer  preferred
=====
```

```
A:dut2# show network-instance default interfaces
=====
Net instance      : default
Interface         : irb1.1
Oper state        : up
Ip mtu            : 1500
Prefix            Origin      Status
=====
10.0.0.2/24      static
2001:db8::2/64   static      preferred
fe80::201:2ff:feff:41/64 link-layer  preferred
=====
Net instance      : default
Interface         : lo0.1
Oper state        : up
Prefix            Origin      Status
=====
2.2.2.2/32       static
2001:db8:1::2/128 static      preferred
=====
```

```
A:dut2# show network-instance MAC-VRF-1 bridge-table mac-table all
-----
```

Mac-table of network instance MAC-VRF-1

address	Destination	Dest Index	Type	Active	Aging	Last Update
00:01:01:FF:00:00	ethernet-1/1.1	16	learnt	true	287	2020-06-03T13:40:25.000Z
00:01:02:FF:00:41	irb-interface	0	irb-interface	true	N/A	2020-06-02T13:53:50.000Z
00:01:03:FF:00:00	ethernet-1/2.1	17	learnt	true	287	2020-06-03T13:40:25.000Z

Total Irb Macs	: 1	Total	1	Active		
Total Static Macs	: 0	Total	0	Active		
Total Duplicate Macs	: 0	Total	0	Active		
Total Learnt Macs	: 2	Total	2	Active		
Total Macs	: 3	Total	3	Active		

A:dut2# show arpnd arp-entries interface irb1

Interface	Subinterface	Neighbor	Origin	Link layer address	Expiry
irb1	1	10.0.0.1	dynamic	00:01:01:FF:00:00	3 hours from now
irb1	1	10.0.0.3	dynamic	00:01:03:FF:00:00	3 hours from now

Total entries : 2 (0 static, 2 dynamic)					

A:dut2# show arpnd neighbors interface irb1

Interface	Sub interface	Neighbor	Origin	Link layer address	Current state	Next state change	Is Router
irb1	1	2001:db8::1	dynamic	00:01:01:FF:00:00	stale	2 hours from now	true
irb1	1	2001:db8::3	dynamic	00:01:03:FF:00:00	stale	2 hours from now	true
irb1	1	fe80::201:1ff:feff:0	dynamic	00:01:01:FF:00:00	stale	2 hours from now	true
irb1	1	fe80::201:3ff:feff:0	dynamic	00:01:03:FF:00:00	stale	2 hours from now	true

Total entries : 4 (0 static, 4 dynamic)							

A:dut2# show network-instance default protocols bgp neighbor

BGP neighbor summary for network-instance "default"

Flags: S static, D dynamic, L discovered by LLDP, B BFD enabled, - disabled, * slow

Net-Inst	Peer	Group	Flag	Peer -AS	State	Uptime	AFI/SAFI	[Rx/Active /Tx]
default	10.0.0.1	tor	SB	64501	established	0d:3h:12m:33s	ipv4-unicast	[3/2/4]
default	10.0.0.3	tor	SB	64503	established	0d:3h:10m:55s	ipv6-unicast	[3/2/4]
default	2001:db8::1	tor	SB	64501	established	0d:3h:12m:31s	ipv4-unicast	[0/0/0]
							ipv6-unicast	[6/0/6]

```

| default | 2001:db8::3 | tor | SB | 64503 | established | 0d:3h:10m:52s | ipv4-unicast | [0/0/0] |
|         |             |     |    |      |             |              | ipv6-unicast | [6/0/6] |
+-----+-----+-----+-----+-----+-----+-----+-----+-----+
Summary:
4 configured neighbors, 4 configured sessions are established,0 disabled peers
0 dynamic peers

```

4.4 Advanced configuration: bridge-table settings

A MAC-VRF network-instance uses a bridge-table to forward frames between its subinterfaces. Some bridge-table properties can be configured. For example:

Example:

```

--{ * candidate shared default }--[ network-instance MAC-VRF-1 bridge-table ]
A:dut2# tree detail
bridge-table! net_inst_mgr
+-- discard-unknown-dest-mac? net_inst_mgr
+-- mac-learning net_inst_mgr
|   +-- admin-state? net_inst_mgr
|   +-- aging net_inst_mgr
|       +-- admin-state? net_inst_mgr
|       +-- age-time? net_inst_mgr
+-- mac-duplication net_inst_mgr
|   +-- admin-state? net_inst_mgr
|   +-- monitoring-window? net_inst_mgr
|   +-- num-moves? net_inst_mgr
|   +-- hold-down-time? net_inst_mgr
|   +-- action? net_inst_mgr
+-- mac-limit net_inst_mgr
|   +-- maximum-entries? net_inst_mgr
|   +-- warning-threshold-pct? net_inst_mgr
+-- static-mac l2_static_mac_mgr
|   +-- mac* [address] l2_static_mac_mgr
|       +-- address l2_static_mac_mgr
|       +-- destination?M l2_static_mac_mgr

```

Where:

- The “mac-learning” container provides control over how MACs are dynamically learned on the subinterfaces, including whether learning is enabled (admin-state) or controlled by the aging timer for the mac-table.
- The “mac-duplication” container controls how the system behaves when duplicate MACs are detected.
- The “mac-limit” container provides parameters for limiting the maximum number of MACs installed for a specific mac-vrf.
- The “static-macs” provides control to configure and associate to either a subinterface destination or with a blackhole. Incoming frames with the source or destination MAC matching a configured “blackholed mac” are discarded by the system.

4.5 Advanced configuration: MAC-duplication for loop protection

SR Linux supports MAC-duplication detection and associated procedures to protect the system against network loops. The following figure shows a simple loop and describes the associated configuration.

Figure 4: MAC-Duplication for loop protection

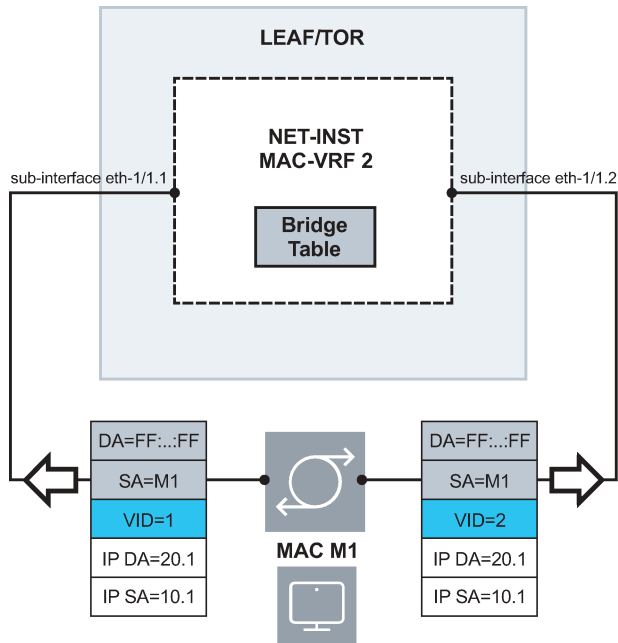

sw2012

In this example, MAC-VRF 2 is connected using two bridged subinterfaces to a layer 2 switch. When a host with MAC M1 sends a broadcast frame, a loop is created. MAC-duplication is, by default, enabled in mac-vrf network-instances with the following parameters:

```
--{ * candidate shared default }--[ network-instance MAC-VRF-1 bridge-table mac-
duplication ]--
A:dut2# info detail
  admin-state enable
  monitoring-window 3
  num-moves 5
  hold-down-time 10
  action stop-learning
```

The loops shown in this example are resolved in the following sequence:

1. MAC-duplication detection.

- A MAC M1 is declared as “duplicate” when the number of moves across two or more subinterfaces exceeds the configured num-moves in the configured monitoring-window.
- When M1 is “duplicate”, it is kept in a duplicate-entries list and stays associated with the last subinterface where the MAC was learned before the number of moves exceed the num-moves value.

2. MAC-duplication action.

- When the MAC M1 is declared “duplicate” in a subinterface, an action is taken in that subinterface. The action is configurable per network-instance and can be overridden on a per-subinterface basis.
- Possible actions on the subinterface are oper-down, blackhole, and stop-learning.
 - oper-down - Brings down the subinterface, breaks the loop, and discards all the frames arriving on the subinterface.
 - blackhole - Discards frames with a source or destination MAC that matches the duplicate MAC. but allows the remaining frames to forward normally on the subinterface.
 - stop-learning - Does not discard any frame on the subinterface and keeps the existing MACs learned against it. No new MACs are learned on the subinterface until the action is cleared.

```
--{ * candidate shared default }--[ network-instance MAC-VRF-1 bridge-table mac-duplication ]--
A:dut2# action <value>
usage: action <blackhole|oper-down|stop-learning>
Action to take on the subinterface whose action is use-net-instance-action,
upon detecting one or more mac addresses as duplicate
In particular:
- Oper-down: if configured, upon detecting a duplicate mac on the subinterface, the subinterface
will be brought oper-down.
- Blackhole: upon detecting a duplicate mac on the subinterface, the mac will be blackholed. Any
frame received on this or any other subinterface with MAC SA matching a blackhole mac is discarded.
- Stop-learning: this is the default action, compliant with RFC7432. Upon detecting a duplicate mac
on the subinterface, the mac will not be relearned anymore on this or any subinterface.
Positional arguments: value
```

3. MAC-duplication hold-down-time and process restart.

- When the configured hold-down-time expires, the duplicate MAC is flushed from the mac-table and the entire process restarts for the MAC.
- The duplicate action on a subinterface clears when there are no longer duplicate MAC addresses in the subinterface.

As a loop protection mechanism, MAC-duplication is self-contained and does not require a control plane protocol that runs network-wide among network devices.

4.5.1 Example: Configure MAC-duplication and troubleshoot loops in DUT2

Procedure

Use this example to assist in configuring MAC-duplication. We assume MAC-VRF 1 is connected to a layer 2 switch (not shown) using two bridge subinterfaces (ethernet-1/1.2 and ethernet-1/1.3). This creates a loop. DUT2 is configured with the following MAC-duplication settings:

Example: DUT2 MAC-duplications settings

```
--{ candidate shared default }--[ network-instance MAC-VRF-1 ]--
A:dut2# info
  type mac-vrf
  admin-state enable
  interface ethernet-1/1.1 {
  }
  interface ethernet-1/1.2 {
  }
  interface ethernet-1/1.3 {
  }
  interface ethernet-1/2.1 {
```

```

}
interface irb1.1 {
}
bridge-table {
  mac-duplication {
    num-moves 3
    hold-down-time 300
    action stop-learning
  }
}
}

```

The subinterfaces are also configured with the following actions:

Example: Subinterface mac-duplication settings

```

--{ * candidate shared default }--[ interface * subinterface * bridge-table mac-
duplication ]--
A:dut2# info
  interface ethernet-1/1 {
    subinterface 1 {
      bridge-table {
        mac-duplication {
        }
      }
    }
    subinterface 2 {
      bridge-table {
        mac-duplication {
          action oper-down
        }
      }
    }
    subinterface 3 {
      bridge-table {
        mac-duplication {
          action oper-down
        }
      }
    }
  }
}

```

In this example, the MAC-duplication action configured under the network-instance is overridden by the more specific action under the subinterfaces 2 and 3. When traffic is generated by the remote layer 2 switch, the same MAC address moves between ethernet-1/1.2 and ethernet-1/1.3. After the third move, the MAC is declared a duplicate and appears in the duplicate-entries list:

Example: Display duplicate MAC entries

```
A:dut2# show network-instance MAC-VRF-1 bridge-table mac-table all
```

```
Mac-table of network instance MAC-VRF-1
```

address	Destination	Dest Index	Type	Active	Aging	Last Update
00:01:01:FF:00:00	ethernet-1/1.1	16	learnt	true	287	2020-06-03T13:40:25.000Z
00:01:01:FF:00:41	ethernet-1/1.3	20	duplicate	true	N/A	2020-06-05T20:07:24.000Z
00:01:02:FF:00:41	irb-interface	0	irb-interface	true	N/A	2020-06-02T13:53:50.000Z
00:01:03:FF:00:00	ethernet-1/2.1	17	learnt	true	287	2020-06-03T13:40:25.000Z
Total Irb Macs : 1 Total 1 Active						
Total Static Macs : 0 Total 0 Active						

```
Total Duplicate Macs      :    1 Total    1 Active
Total Learnt Macs        :    2 Total    2 Active
Total Macs                :    4 Total    4 Active
```

```
A:dut2# show network-instance MAC-VRF-1 bridge-table mac-duplication duplicate-entries
```

```
Mac-Duplication in network instance MAC-VRF-1
```

```
Admin state           : enable
Monitoring window     : 3
Number of moves allowed: 3
Hold down time        : 300
Action                 : stop-learning
```

Duplicate MAC	Destination	Dest Index	Detect Time	Hold Time Remaining
00:01:01:FF:00:41	ethernet-1/1.3	20	2020-06-05T20:07:24.000Z	270

```
Total Duplicate Macs      :    1 Total    0 Active
```

4.5.2 Using logs to detect duplicate MACs

Procedure

A log event can help to troubleshoot when MACs are detected as duplicate, or when they are deleted after the hold-down-timer. For example:

Example

```
[root@dut2 srlinux]# tail -f /var/log/srlinux/debug/sr_l2_mac_mgr.log
2020-06-06T06:22:48.679070+00:00 dut2 local6|NOTI sr_l2_mac_mgr: bridgetable|2608|2608|00035|N:
  A duplicate MAC address 00:01:01:FF:00:00 was detected on MAC-VRF-1.
2020-06-06T06:27:48.933312+00:00 dut2 local6|NOTI sr_l2_mac_mgr: bridgetable|2608|2608|00036|N:
  A duplicate MAC address 00:01:01:FF:00:00 detected on MAC-VRF-1 is now deleted.
```

The network-instance manager logs also show when the subinterfaces go down as a result of MAC-duplication. For example:

Example

```
[root@dut2 srlinux]# tail -f /var/log/srlinux/debug/sr_net_inst_mgr.log
2020-06-06T06:22:48.680609+00:00 dut2 local6|WARN sr_net_inst_mgr: netinst|2663|2663|00080|W:
  The interface ethernet-1/1.3 in network-instance MAC-VRF-1 is now down for reason:
  A duplicate MAC address has been detected
```

5 EVPN-VXLAN for layer-2 and multi-homing

Ethernet Virtual Private Network (EVPN) is a standard technology in multi-tenant Data Centers (DCs). EVPN provides a control frame framework for many functions. This chapter details the configuration and operation of an EVPN and VXLAN (EVPN-VXLAN) solution for the following components:

- Bridged sub-Interfaces associated with a specific vlan-id or default sub-interfaces, that capture untagged and non-explicitly configured vlan-tagged frames in tagged sub-interfaces.
- MAC-VRF type network-instances that are EVPN-enabled so that they can use Virtual Extended LAN (VXLAN) tunnels to connect to other MAC-VRFs of the same Broadcast Domains (BD).
- EVPN-VXLAN control and data plane extensions as in [RFC8365], including EVPN route type 2 (MAC/IP) and route type 2 (Inclusive Multicast Ethernet Tag [IMET]).
- Distributed security and protection for static-macs.
- The MAC duplication mechanism, extended to support EVPN, to provide loop protection.
- EVPN L2 multi-homing, including Ethernet Segment (ES) model configuration for all-active multi-homing.

5.1 Applicability

The information and configuration in this chapter are based on SR Linux Release 21.3.

5.2 Overview

EVPN-VXLAN provides Layer-2 connectivity in multi-tenant DCs. EVPN-VXLAN Broadcast Domains (BD) can span several leaf routers connected to the same IP fabric, allowing hosts attached to the same BD to communicate as though they were connected to the same layer-2 switch. VXLAN tunnels bridge the layer-2 frames between leaf routers with EVPN providing the control plane to automatically setup tunnels and use them efficiently.

The following diagram shows this concept. In this example, four leaf routers are attached to the same BD that is instantiated by a MAC-VRF on each leaf. SR Linux leaf routers support standard-based EVPN-VXLAN [RFC8365]; therefore third-party leaf routers (LEAF-4 in this example) can be attached to the same BD as the SR Linux leaf routers as long as they follow standard [RFC8365].

Figure 5: EVPN broadcast domain in a multi-tenant DCs

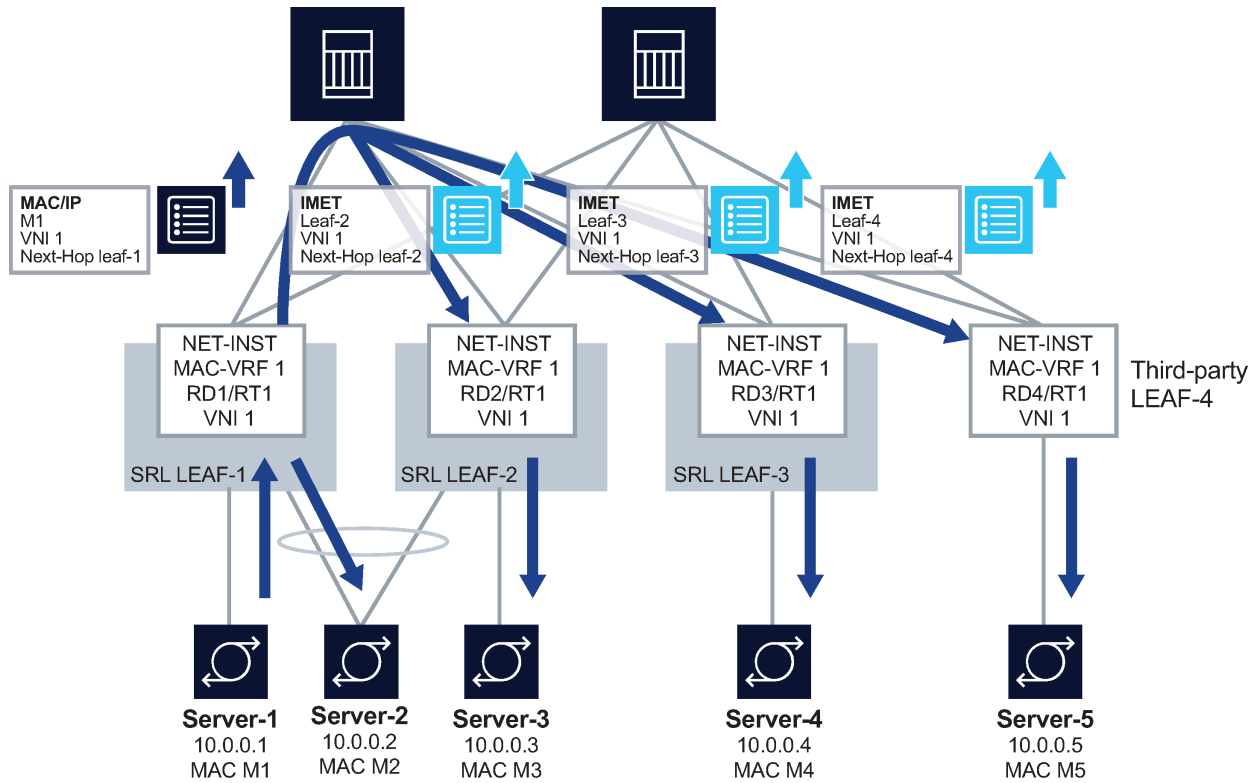

sw4043

5.3 Configuration of EVPN-VXLAN broadcast domains

The following figure shows a configuration example of an EVPN-VXLAN BD that is distributed in multiple leaf nodes in the same DC. The BD is instantiated by MAC-VRF-1 in each of the three leaf nodes. The sections that follow describe how to configure and operate MAC-VRF-1 in each node.

Figure 6: Example of EVPN-VXLAN broadcast domain

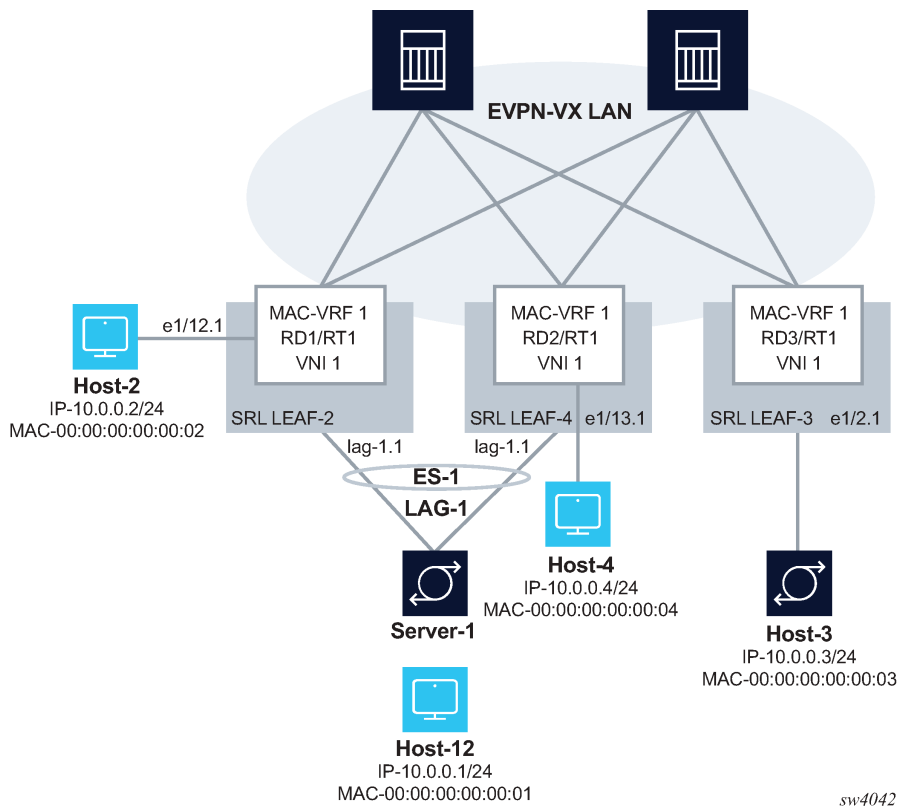

5.3.1 Configuring the underlay network

About this task

Before configuring the overlay BD, the underlay connectivity must be configured. In [Figure 6: Example of EVPN-VXLAN broadcast domain](#), the leaf routers are connected to the spines using routed links. A routing protocol is enabled in the default network-instance of each leaf and spine node, so that reachability of all the leaf VXLAN Termination End Point (VTEP) addresses is distributed throughout the IP fabric. In SR Linux, you can use the following for the underlay routing protocol:

- ISIS
- OSPF
- eBGP

The EVPN family must also be enabled for the distribution of EVPN routes among leaf routers of the same tenant. EVPN is enabled using iBGP and typically a Route Reflector (RR), or eBGP.

Procedure

As an example, the following configuration on LEAF-3 shows an eBGP-underlay BGP group to enable the IPv4 and IPv6 unicast families, and an iBGP-evpn group for the distribution of the EVPN routes. A full mesh of iBGP EVPN sessions is established among the three leaf routers, but a pair of RRs is typical.

Example: Underlay Configuration

```
--{ [FACTORY] + candidate shared default }--[ network-instance default ]--
A:dut3# info
  type default
  admin-state enable
  description "Default network instance"
  router-id 3.3.3.3
  interface ethernet-1/1.1 {
  }
  interface ethernet-1/3.1 {
  }
  interface system0.0 {
  }
  protocols {
    bgp {
      admin-state enable
      afi-safi ipv4-unicast {
        admin-state enable
      }
      autonomous-system 3333
      router-id 3.3.3.3
      group eBGP-underlay {
        admin-state enable
        export-policy export-all
        import-policy import-all
        timers {
          connect-retry 5
          hold-time 5
          keepalive-interval 2
          minimum-advertisement-interval 2
        }
      }
      group iBGP-evpn {
        admin-state enable
        export-policy export-all
        import-policy import-all
        afi-safi evpn {
          admin-state enable
        }
        local-as as-number 1234 {
        }
        timers {
          minimum-advertisement-interval 1
        }
      }
      afi-safi ipv4-unicast {
        admin-state enable
      }
      afi-safi ipv6-unicast {
        admin-state enable
      }
      neighbor 1.1.1.1 {
        admin-state enable
        peer-as 1234
        peer-group iBGP-evpn
        transport {
          local-address 3.3.3.3
        }
      }
      neighbor 2.2.2.2 {
        admin-state enable
        peer-as 1234
        peer-group iBGP-evpn
      }
    }
  }
}
```

```

        transport {
            local-address 3.3.3.3
        }
    }
    neighbor 4.4.4.4 {
        admin-state enable
        peer-as 1234
        peer-group iBGP-evpn
        transport {
            local-address 3.3.3.3
        }
    }
    neighbor 10.2.3.2 {
        admin-state enable
        peer-as 2222
        peer-group eBGP-underlay
    }
    neighbor 10.3.4.4 {
        admin-state enable
        peer-as 4444
        peer-group eBGP-underlay
    }
    }
    trace-options {
        flag packets {
            modifier detail
        }
        flag update {
            modifier detail
        }
        flag route {
            modifier detail
        }
        flag socket {
            modifier detail
        }
        flag notification {
            modifier detail
        }
    }
}
linux {
    export-routes true
    export-neighbors true
}
}

```

In the example above, eBGP is used for underlay reachability, and iBGP for overlay EVPN route distribution. The command **local-as** overrides the configuration of the `bgp>autonomous-system` so that the overlay BGP sessions are established using the same autonomous system in the three leaf routers.

The `system0.0` interface hosts the loopback address used to originate and typically terminate VXLAN packets. This address is also used by default as the next-hop of all EVPN routes.

Example: system0.0 interface configuration

The following example shows the configuration of the `system0.0` interface in LEAF-3.

```

--{ [FACTORY] + candidate shared default }--[ interface system0 ]--
A:dut3# info
    admin-state enable
    subinterface 0 {
        admin-state enable
    }
}

```

```

    ipv4 {
      address 3.3.3.3/32 {
      }
    }
  }
}

```

5.3.2 Configuring LEAF-3 with an EVPN-VXLAN enabled MAC-VRF

About this task

After LEAF-3 is configured as defined in [Configuring the underlay network](#), use the following steps to enable EVPN-VXLAN on LEAF-3.

In this example, Ethernet-1/2 connects HOST-3 to LEAF-3. Although this interface could be defined untagged, this example configures the interface as tagged and using vlan-id (vlan-tagging true).

A subinterface with index 1 is created under the interface. The subinterface must be configured as type bridged. Bridged subinterfaces can be associated with MAC-VRF instances so that MAC learning and layer-2 forwarding can be enabled on each.

Procedure

Step 1. In candidate mode, create the interfaces and bridged subinterfaces to connect LEAF-3 to HOST-3.

Example

creation of interfaces/bridged subinterfaces

```

--{ [FACTORY] + candidate shared default }--[ interface ethernet-1/2 ]--
A:dut3# info
  description dut3_host3
  admin-state enable
  vlan-tagging true
  subinterface 1 {
    type bridged
    admin-state enable
    vlan {
      encap {
        single-tagged {
          vlan-id 1
        }
      }
    }
  }
}

```

In the above example, the subinterface uses vlan-id 1 since this is the VLAN ID used by HOST-3 to send and receive frames. If you wanted HOST-3 to send and received untagged traffic, the vlan encap command can be configured with either of these options:

- **vlan encap single-tagged vlan-id any** - where 'any' captures all traffic when no specific vlan-id has been defined.
- **vlan encap untagged** - where 'untagged' captures traffic with no tags or vlan-tag 0.

Step 2. After creating the access subinterfaces, create the vxlan-interfaces.

This allows MC-VRFs of the same BD to be connected throughout the IP fabric.

The SR Linux models VXLAN as tunnels and vxlan-interfaces exist within them. The network-instance and main property is the VNI or VXLAN network identifier. SR Linux VXLAN model characteristics include:

- The tunnel-interface for vxlan is configured as vxlan<N> where the value of N is 0-255.
- Multiple tunnel-interfaces can be configured. The tunnel-interface can host multiple vxlan-interfaces.
- vxlan-interfaces are configured under tunnel-interfaces with an associated number in the range 0-4294967295. Minimally, the vxlan-interface must have an index, type, and ingress VNI.
- A vxlan-interface can only be associated with one network-instance, and in the R21.3, a network-instance can have only one vxlan-interface.
- The vxlan-interface type can be routed or bridged. When used for EVPN-VXLAN Layer-2 in MAC-VRFs, the type must be "bridged".
- The ingress VNI must be configured. The VNI is used to find the MAC-VRF where the inner MAC lookup is performed. The egress VNI is *not* configured and is determined by the imported EVPN routes. SR Linux requires that the egress VNI (discovered) matches the configured ingress VNI so that two leaf routers attached to the same BD can exchange packets.

Example

vxlan1 vxlan-interface configuration

```
--{ [FACTORY] + candidate shared default }--[ tunnel-interface * ]--
A:dut3# info
  tunnel-interface vxlan1 {
    vxlan-interface 1 {
      type bridged
      ingress {
        vni 1
      }
    }
  }
}
```

Outer VLAN tagging is supported (one VLAN tag only), assuming that the egress subinterface in the default network-instance uses vlan-tagging. No inner VLAN tags can be pushed or popped on vxlan-interfaces, but vlan tags that are not stripped-off at the ingress bridged subinterfaces are transparently carried over the VXLAN tunnels.

The following applies for MTU and fragmentation for VXLAN interfaces:

- No specific MTU checks are performed in network-instances with VXLAN.
- The default network-instance interface MTU should be made large enough to allow room for the VXLAN overhead.
- The Don't Fragment (DF) flag is always set in the VXLAN outer IP header.
- Reassembly is not supported for VXLAN packets.

Step 3. Configure the network-instance type mac-vrf and associate it with the bridged interfaces and vxlan-interface to.

A bgp-evpn enabled mac-vrf requires the association of at least one bridged subinterface and one bridged vxlan-interface.

Example

mac-vrf configuration and bridged interface association

```
--{ [FACTORY] + candidate shared default }--[ network-instance MAC-VRF-1 ]--
A:dut3# info
  type mac-vrf
  admin-state enable
  interface ethernet-1/2.1 {
  }
  vxlan-interface vxlan1.1 {
  }
```

Step 4. Enable EVPN in the mac-vrf by configuring the bgp-vpn and the bgp-evpn protocol containers:

- **bgp-vpn** - Provides the configuration of the bgp-instances where the route-distinguisher and the import/export route-targets used for the EVPN routes exist. Import and export policies can be used instead of explicit route-targets. In the current release, only one bgp-instance per network-instance is supported.
- **bgp-evpn** - Hosts all the commands required to enable EVPN in the network-instance. At a minimum, a reference to bgp-instance 1 is configured, along with the reference to the vxlan-interface (where EVPN is enabled) and the EVI. The EVI or EVPN Instance identifier is a two-byte value that is mandatory, and is used for:
 - The auto-derivation of the route-distinguisher (RD). If a manual RD is not configured, the RD is auto-derived as system-ip:evi. Where the system-ip is the IP address configured in the system0.0 subinterface.
 - The auto-derivation of the route-target (RT). If a manual RT is not configured, the RT is auto-derived as autonomous-system:evi. The autonomous-system is configured in the default network-instance.
 - The value used to represent the MAC-VRF in the DF Election algorithm. See [Multi-homing configuration for EVPN broadcast domains](#).

Example

Configure bgp-vpn and bgp-evpn protocol containers

```
--{ [FACTORY] + candidate shared default }--[ network-instance MAC-VRF-1 ]--
A:dut3# info
  type mac-vrf
  admin-state enable
  interface ethernet-1/2.1 {
  }
  vxlan-interface vxlan1.1 {
  }
  protocols {
    bgp-evpn {
      bgp-instance 1 {
        admin-state enable
        vxlan-interface vxlan1.1
        evi 1
        ecmp 2
      }
    }
    bgp-vpn {
      bgp-instance 1 {
        route-target {
          export-rt target:1234:1
          import-rt target:1234:1
        }
      }
    }
  }
```



```
VxLAN-Interface : vxlan1.1
Type           : bridged
Oper state     : up
Oper-down-reason: None
=====
```

5.3.3.2 Checking mac-vrf, bgp-vpn, and bgp-evpn parameters

Procedure

The following command checks that the mac-vrf, bgp-vpn, and bgp-evpn parameters are properly configured. A manual or auto-derived RD/RT must exist, or the bgp-evpn bgp-instance will be oper-down.

Example: Check mac-vrf, bgp-vpn, and bgp-evpn parameters

```
A:dut3# show network-instance MAC-VRF-1 protocols bgp-vpn bgp-instance 1
=====
Net Instance   : MAC-VRF-1
  bgp Instance 1
-----
      route-distinguisher: 3.3.3.3:1, auto-derived-from-evi
      export-route-target: target:1234:1, manual
      import-route-target: target:1234:1, manual
=====
--{ [FACTORY] + candidate shared default }--[ ]--
A:dut3# show network-instance MAC-VRF-1 protocols bgp-evpn bgp-instance 1
=====
Net Instance   : MAC-VRF-1
  bgp Instance 1 is enabled and None
-----
      VXLAN-Interface   : vxlan1.1
      evi                : 1
      ecmp               : 2
      default-admin-tag : 0
      oper-down-reason  : N/A
      EVPN Routes
        Next hop         : None
        MAC/IP Routes   : None
        IMET Routes     : None, originating-ip None
=====
--{ [FACTORY] + candidate shared default }--[ ]--
```

5.3.3.3 Checking VXLAN tunnels

Procedure

This example checks for the creation of VXLAN tunnels to the remote VTEPs. After receiving EVPN routes from the remote leaf routers with VXLAN encapsulation, the vxlan_mgr creates VTEPs from the EVPN routes next-hops. Each VTEP gets an index allocated by fib_mgr (per source and destination tunnel IP addresses) if the next-hop is resolved in the default network-instance. The state of the two remote VTEPs is shown with their own indexes. EVPN routes are received with Next Hops 2.2.2.2 and 4.4.4.4 respectively.

Example: Check VXLAN tunnels

```
--{ [FACTORY] + candidate shared default }--[ ]--
```

```
A:dut3# show tunnel vxlan-tunnel all
-----
Show report for vxlan-tunnels
-----
+-----+-----+-----+
| VTEP Address | Index | Last Change |
+-----+-----+-----+
| 2.2.2.2 | 278779228830 | 2021-02-15T11:07:23.000Z |
| 4.4.4.4 | 278779228829 | 2021-02-15T18:15:28.000Z |
+-----+-----+-----+
2 VXLAN tunnels, 2 active, 0 inactive
-----
```

5.3.3.4 Checking tunnel-table entries

Procedure

The following command displays all tunnel-table entries. When a VTEP is created in the vxlan-tunnel table and a non-zero index is allocated, a tunnel-table entry is created in the tunnel-table of the default network-instance.

If the next hop is not resolved to a route in the default network-instance route-table, the index in the vxlan-tunnel table shows as "0" for the VTEP and no tunnel-table is created. If the tunnel prefix in the tunnel-table is resolved, but the system runs out of hardware index resources, the tunnel shows in the tunnel-table, but is not programmed. A non-programmed-reason is displayed.

Example: Check tunnel-table entries

```
--{ [FACTORY] + candidate shared default }--[ ]--
A:dut3# show network-instance default tunnel-table all
-----
Show report for network instance "default" tunnel table
-----
+-----+-----+-----+-----+-----+-----+-----+-----+
| IPv4 Prefix | Owner | Type | Index | Metric | Preference | Fib-prog | Last Update |
+-----+-----+-----+-----+-----+-----+-----+-----+
| 2.2.2.2/32 | vxlan_mgr | vxlan | 4 | 0 | 0 | Y | 2021-03-01T10:41:38.590Z |
| 4.4.4.4/32 | vxlan_mgr | vxlan | 5 | 0 | 0 | Y | 2021-03-01T10:45:08.633Z |
+-----+-----+-----+-----+-----+-----+-----+-----+
2 VXLAN tunnels, 2 active, 0 inactive
-----
-----
Show report for network instance "default" tunnel table
-----
```

5.3.3.5 Checking statistics

Procedure

When the three leaf routers exchange packets over the VXLAN, LEAF-3 displays statistics for all individual VTEPs. Statistics include:

- Global-level ingress/egress packets and octets. Global in/out octets and packets are aggregations of the individual statistics per VTEP. "in-discarded-packets" are vxlan packets discarded as a result of a non-existent local VNI, packets from a source VTEP are not discovered in the control plan, and packets are not aggregations of individual per VTEP dropped packets

- Per VTEP packets and octets with in/out discarded packets.

Example: Check statistics

```
--{ [FACTORY] + candidate shared default }--[ ]--
A:dut3# info from state tunnel vxlan-tunnel
  tunnel {
    vxlan-tunnel {
      vtep 2.2.2.2 {
        index 278779228830
        last-change "8 hours ago"
        statistics {
          in-octets 0
          in-packets 0
          in-discarded-packets 0
          out-octets 0
          out-packets 0
          out-discarded-packets 0
        }
      }
      vtep 4.4.4.4 {
        index 278779228829
        last-change "an hour ago"
        statistics {
          in-octets 555720
          in-packets 5052
          in-discarded-packets 0
          out-octets 0
          out-packets 0
          out-discarded-packets 0
        }
      }
      statistics {
        in-octets 555720
        in-packets 5052
        in-discarded-packets 0
        out-octets 0
        out-packets 0
      }
    }
  }
}
```

Statistics can be cleared using the command: **tools tunnel vxlan-tunnel vtep 2.2.2.2 statistics clear**

5.3.3.6 Checking for received IMET routes and multicast destination creation

Procedure

IMET routes are used for auto-discovery and the creation of the default flood list for vxlan in the MAC-VRF. When LEAF-3 receives and imports the IMET routes from LEAF-2 and LEAF-4, it creates a VXLAN default flood list. BUM frames received on a bridged subinterface are ingress-replicated to the VTEPs on the list.

The following command checks that the IMET routes for the BD from LEAF-2 and LEAF-4 have been received and they have created multicast destinations in the MAC-VRF. Note that the VNI is received in the PMSI tunnel attribute and not in the route's Network Layer Reachability Information (NLRI).

Example: Check for received IMET routes and multicast destination creation

```
--{ [FACTORY] + candidate shared default }--[ ]--
```

```

A:dut3# show network-instance default protocols bgp routes evpn route-type 3 detail
-----
Show report for the EVPN routes to network "*" network-instance "default"
-----
Route Distinguisher: 2.2.2.2:1
Tag-ID           : 0
Originating router : 2.2.2.2
neighbor         : 2.2.2.2
Received paths    : 1
  Path 1: <Best,Valid,Used,>
    VNI           : 1
    Route source   : neighbor 2.2.2.2 (last modified 9h11m44s ago)
    Route preference: No MED, LocalPref is 100
    Atomic Aggr    : false
    BGP next-hop   : 2.2.2.2
    AS Path        : i
    Communities    : [target:1234:1, bgp-tunnel-encap:VXLAN]
    RR Attributes  : No Originator-ID, Cluster-List is []
    Aggregation    : None
    Unknown Attr   : None
    Invalid Reason : None
    Tie Break Reason: none
-----
Route Distinguisher: 4.4.4.4:1
Tag-ID           : 0
Originating router : 4.4.4.4
neighbor         : 4.4.4.4
Received paths    : 1
  Path 1: <Best,Valid,Used,>
    VNI           : 1
    Route source   : neighbor 4.4.4.4 (last modified 9h11m44s ago)
    Route preference: No MED, LocalPref is 100
    Atomic Aggr    : false
    BGP next-hop   : 4.4.4.4
    AS Path        : i
    Communities    : [target:1234:1, bgp-tunnel-encap:VXLAN]
    RR Attributes  : No Originator-ID, Cluster-List is []
    Aggregation    : None
    Unknown Attr   : None
    Invalid Reason : None
    Tie Break Reason: none
-----
--{ [FACTORY] + candidate shared default }--[ ]--
--{ [FACTORY] + candidate shared default }--[ ]--
A:dut3# info from state network-instance default bgp-rib evpn rib-in-out rib-in-post imet-
routes * originating-router * ethernet-tag-id * neighbor *
network-instance default {
  bgp-rib {
    evpn {
      rib-in-out {
        rib-in-post {
          imet-routes 2.2.2.2:1 originating-router 2.2.2.2 ethernet- tag-id
0 neighbor 2.2.2.2 {
      attr-id 193
      last-modified 2021-02-15T11:07:21.500Z
      used-route true
      valid-route true
      best-route true
      stale-route false
      pending-delete false
      tie-break-reason none
      invalid-reason {
        rejected-route false
        as-loop false

```



```

Mac-table of network instance MAC-VRF-1
-----
+-----+-----+-----+-----+-----+-----+-----+
| Address | Destination | Dest Index | Type | Active | Aging | Last Update |
+-----+-----+-----+-----+-----+-----+-----+
| 00:00:00:00:00:01 | vxlan-interface:vxlan1.1 | 2787792288 | evpn | true | N/A | 2021-02-16T10:54:54.000Z |
| 00:00:00:00:00:02 | vxlan-interface:vxlan1.1 | 2787792288 | evpn | true | N/A | 2021-02-16T10:54:54.000Z |
| 00:00:00:00:00:03 | ethernet-1/2.1 | 12 | learnt | true | 300 | 2021-02-16T10:54:54.000Z |
| 00:00:00:00:00:04 | vxlan-interface:vxlan1.1 | 2787792288 | evpn | true | N/A | 2021-02-16T10:54:54.000Z |
+-----+-----+-----+-----+-----+-----+-----+
Total Irb Macs : 0 Total 0 Active
Total Static Macs : 0 Total 0 Active
Total Duplicate Macs : 0 Total 0 Active
Total Learnt Macs : 1 Total 1 Active
Total Evpn Macs : 3 Total 3 Active
Total Irb anycast Macs : 0 Total 0 Active
Total Macs : 4 Total 4 Active
-----
--{ [FACTORY] + candidate shared default }--[ ]--
A:dut3# show network-instance default protocols bgp routes evpn route-type 2 summary
-----
Show report for the BGP route table of network-instance "default"
-----
Status codes: u=used, *=valid, >=best, x=stale
Origin codes: i=IGP, e=EGP, ?=incomplete
-----
BGP Router ID: 3.3.3.3 AS: 3333 Local AS: 3333
-----
Type 2 MAC-IP Advertisement Routes
+-----+-----+-----+-----+-----+-----+-----+
| Status | Route-dis- | Tag | MAC-address | IP- | Neighbor | Next- | VNI | ESI | MAC |
| | tinguisher | ID | | address | | Hop | | | Mob. |
+-----+-----+-----+-----+-----+-----+-----+
| u*> | 2.2.2.2:1 | 0 | 00:00:00:00:00:02 | 0.0.0.0 | 2.2.2.2 | 2.2.2.2 | 1 | 00:00:00:00:00:00 | - |
| u*> | 4.4.4.4:1 | 0 | 00:00:00:00:00:01 | 0.0.0.0 | 4.4.4.4 | 4.4.4.4 | 1 | 01:24:24:24:24:24 | - |
| u*> | 4.4.4.4:1 | 0 | 00:00:00:00:00:04 | 0.0.0.0 | 4.4.4.4 | 4.4.4.4 | 1 | 24:00:00:01 | - |
| | | | | | | | | 00:00:00:00:00:00 | 0 |
+-----+-----+-----+-----+-----+-----+-----+
3 MAC-IP Advertisement routes 3 used, 3 valid
-----
--{ [FACTORY] + candidate shared default }--[ ]--

```

5.3.3.9 Checking unicast destinations

Procedure

The reception of MAC/IP routes also creates unicast destinations in the vxlan-interface. In some cases, the unicast destinations are Ethernet Segment (ES) destinations if the MAC/IP routes are advertised from an ES. See [Multi-homing configuration for EVPN broadcast domains](#) for details. The following command displays the unicast destinations.

Example: Check unicast destinations

```
--{ [FACTORY] + candidate shared default }--[ ]--
A:dut3# show tunnel-interface vxlan1 vxlan-interface 1 bridge-table unicast-destinations destination *
-----
Show report for vxlan-interface vxlan1.1 unicast destinations
-----
Destinations
-----
+-----+-----+-----+-----+
| VTEP Address | Egress VNI | Destination-index | Number MACs (Active/Failed) |
+-----+-----+-----+-----+
| 2.2.2.2      | 1          | 278779228840     | 1(1/0)                       |
| 4.4.4.4      | 1          | 278779228838     | 1(1/0)                       |
+-----+-----+-----+-----+
-----
Ethernet Segment Destinations
-----
+-----+-----+-----+-----+
|          ESI          | Destination-index | VTEPs          | Number MACs (Active/Failed) |
+-----+-----+-----+-----+
| 01:24:24:24:24:24:00:00:01 |                | 2.2.2.2, 4.4.4.4 | 0(0/0)                       |
+-----+-----+-----+-----+
-----
Summary
  3 unicast-destinations, 2 non-es, 1 es
  2 MAC addresses, 2 active, 0 non-active
-----
--{ [FACTORY] + candidate shared default }--[ ]--
```

5.3.4 Checking MAC mobility, MAC protection and MAC loop protection in EVPN-VXLAN BDs

MAC mobility and MAC protection are implemented following [RFC7432]. MAC loop protection follows [draft-ietf-bess-rfc7432bis].

5.3.4.1 Checking MAC mobility**Procedure**

MAC Mobility is an event that triggers the fast move and re-learn of a MAC in a different leaf router. Mobility is common in DCs with some workloads moving between racks in the same DC. EVPN provides tools for fast mobility because MAC/IP routes are advertised with a sequence number that indicates the latest location of a MAC. This sequence number is used by the leaf routers to program the MAC with the correct VXLAN destination.

Example: MAC mobility (1 of 2)

Using [Figure 6: Example of EVPN-VXLAN broadcast domain](#) as reference, if HOST-2 moves from LEAF-2 to LEAF-3, and you review the programming of the MAC in LEAF-4, MAC 00:00:00:00:00:02 is learned against VXLAN destination vtep:2.2.2.2 vni:1:

```
--{ [FACTORY] + candidate shared default }--[ network-instance MAC-VRF-1 bridge-table ]--
A:dut4# /show network-instance MAC-VRF-1 bridge-table mac-table all
-----
Mac-table of network i
```

Address	Destination	Dest Index	Type	Active	Aging	Last Update
00:00:00:00:00:01	lag1.1	11	learnt	true	300	2021-02-16T11:32:14.000Z
00:00:00:00:00:02	vxlان-interface:vxlan1.1 vtep:2.2.2.2 vni:1	2787793311 82	evpn	true	N/A	2021-02-16T11:32:15.000z
00:00:00:00:00:03	vxlان-interface:vxlan1.1 vtep:3.3.3.3 vni:1	2787793311 84	evpn	true	N/A	2021-02-16T11:32:15.000Z
00:00:00:00:00:04	ethernet-1/13.1	13	learnt	true	300	2021-02-16T11:32:14.000Z
00:CA:FE:CA:FE:04	ethernet-1/13.1	13	static	true	N/A	2021-02-16T11:10:26.000Z

Total Irb Macs	: 0	Total 0	Active			
Total Static Macs	: 1	Total 1	Active			
Total Duplicate Macs	: 0	Total 0	Active			
Total Learnt Macs	: 2	Total 2	Active			
Total Evpn Macs	: 2	Total 2	Active			
Total Evpn static Macs	: 0	Total 0	Active			
Total Irb anycast Macs	: 0	Total 0	Active			
Total Macs	: 5	Total 5	Active			

Example: MAC mobility (2 of 2)

After the mobility event, LEAF-4 receives the MAC with a higher sequence number. This makes LEAF-4 reprogram the MAC against LEAF-3 as shown below:

```

2021-02-16T03:33:53.505253-08:00 dut4 local6|DEBU sr_bgp_mgr: bgp|4959|5178|402506|D:
VR default (1) Peer 1: 3.3.3.3 UPDATE: Peer 1: 3.3.3.3 - Received BGP UPDATE:
  Withdrawn Length = 0
  Total Path Attr Length = 96
  Flag: 0x90 Type: 14 Len: 44 Multiprotocol Reachable NLRI:
    Address Family EVPN
    NextHop len 4 NextHop 3.3.3.3
    Type: EVPN-MAC Len: 33 RD: 3.3.3.3:1 ESI: ESI-0, tag: 0, mac len: 48 mac: 00:00:00:00:00:02,
      IP len: 0, IP: NULL, label: 1
  Flag: 0x40 Type: 1 Len: 1 Origin: 0
  Flag: 0x40 Type: 2 Len: 0 AS Path:
  Flag: 0x80 Type: 4 Len: 4 MED: 0
  Flag: 0x40 Type: 5 Len: 4 Local Preference: 100
  Flag: 0xc0 Type: 16 Len: 24 Extended Community:
    target:1234:1
    bgp-tunnel-encap:VXLAN
    mac-mobility:Seq:1
-- { [FACTORY] + candidate shared default } -- [ ] --

A:dut4# show network-instance MAC-VRF-1 bridge-table mac-table all
-----
-
Mac-table of network instance MAC-VRF-1
-----
+-----+-----+-----+-----+-----+-----+-----+
|
| Address      | Destination      | Dest Index | Type  | Active | Aging  | Last Update
|-----+-----+-----+-----+-----+-----+-----+
| 00:00:00:00:00:01 | lag1.1          | 11         | learnt | true   | 180    | 2021-02-16T11:
|

```

```

| | | | | | | 32:14.000Z
| | 00:00:00:00:00:02 | vxlan-interface:vxlan1.1 | 2787793311 | evpn | true | N/A | 2021-02-16T11:
| | | | | | | 33:54.000Z
| | 00:00:00:00:00:03 | vxlan-interface:vxlan1.1 | 2787793311 | evpn | true | N/A | 2021-02-16T11:
| | | | | | | 32:15.000Z
| | 00:00:00:00:00:04 | ethernet-1/13.1 | 13 | learnt | true | 180 | 2021-02-16T11:
| | | | | | | 32:14.000Z
| | 00:CA:FE:CA:FE:04 | ethernet-1/13.1 | 13 | static | true | N/A | 2021-02-16T11:
| | | | | | | 10:26.000Z
+-----+-----+-----+-----+-----+-----+
+
Total Irb Macs : 0 Total 0 Active
Total Static Macs : 1 Total 1 Active
Total Duplicate Macs : 0 Total 0 Active
Total Learnt Macs : 2 Total 2 Active
Total Evpn Macs : 3 Total 3 Active
Total Evpn static Macs : 0 Total 0 Active
Total Irb anycast Macs : 0 Total 0 Active
Total Macs : 5 Total 5 Active
-----
-
--{ [FACTORY] + candidate shared default }--[ ]--

```

5.3.4.2 Checking MAC protection

Procedure

MAC protection refers to the property of a MAC that does not move between leaf routers. It is always learned against a bridged subinterface. You can configure this MAC as static, but should observe the following:

- When a MAC is programmed as static, the same MAC cannot be learned in another sub-interface or via EVPN. If frames arriving on an interface are different than the ones associated with the static MAC, they are discarded.
- The MAC is now advertised as "static" in EVPN and installed as "evpn-static" in the leaf routers attached to the same BD. If programmed, evpn-static MACs are also protected. Therefore, frames arriving on a local subinterface are discarded if their source MAC matches an evpn-static MAC.

Example: MAC protection (1 of 2)

Using [Figure 6: Example of EVPN-VXLAN broadcast domain](#) as reference, the following commands show MAC 00:ca:fe:ca:fe:04 is configured as static in LEAF-4.

```

--{ [FACTORY] +* candidate shared default }--[ network-instance MAC-VRF-1 bridge-table ]--
A:dut4# info
  static-mac {
    mac 00:CA:FE:CA:FE:04 {
      destination ethernet-1/13.1
    }
  }

```



```

}
--{ [FACTORY] +* candidate shared default }--[ network-instance MAC-VRF-1 bridge-table ]--
A:dut4# commit stay
All changes have been committed. Starting new transaction.
--{ [FACTORY] + candidate shared default }--[ network-instance MAC-VRF-1 bridge-table ]--
A:dut4#
--{ [FACTORY] + candidate shared default }--[ network-instance MAC-VRF-1 bridge-table ]--
A:dut4# /show network-instance MAC-VRF-1 bridge-table mac-table all
-----
Mac-table of network instance MAC-VRF-1
-----
+-----+-----+-----+-----+-----+-----+-----+
| Address | Destination | Dest Index | Type | Active | Aging | Last Update |
+-----+-----+-----+-----+-----+-----+-----+
| 00:00:00:00:00:01 | lag1.1 | 11 | learnt | true | 180 | 2021-02-16T11:08:10.000Z |
| 00:00:00:00:00:02 | vxlan-interface:vxlan1.1 | 2787793311 | evpn | true | N/A | 2021-02-16T11:08:11.000Z |
| 00:00:00:00:00:03 | vxlan-interface:vxlan1.1 | 2787793311 | evpn | true | N/A | 2021-02-16T11:08:11.000Z |
| 00:00:00:00:00:04 | ethernet-1/13.1 | 13 | learnt | true | 180 | 2021-02-16T11:08:10.000Z |
| 00:CA:FE:CA:FE:04 | ethernet-1/13.1 | 13 | static | true | N/A | 2021-02-16T11:10:26.000Z |
+-----+-----+-----+-----+-----+-----+-----+
Total Irb Macs : 0 Total 0 Active
Total Static Macs : 1 Total 1 Active
Total Duplicate Macs : 0 Total 0 Active
Total Learnt Macs : 2 Total 2 Active
Total Evpn Macs : 2 Total 2 Active
Total Evpn static Macs : 0 Total 0 Active
Total Irb anycast Macs : 0 Total 0 Active
Total Macs : 5 Total 5 Active
-----
--{ [FACTORY] + candidate shared default }--[ network-instance MAC-VRF-1 bridge-table ]--

```

Example: MAC protection (2 of 2)

On the remote leaf routers, the MAC is received as evpn-static and programmed this way. For example, LEAF-4 receives the route and programs it as follows:

```

2021-02-16T03:10:27.402653-08:00 dut3 local6|DEBU sr_bgp_mgr: bgp|4628|4789|270039|D:
VR default (1) Peer 1: 4.4.4.4 UPDATE: Peer 1: 4.4.4.4 - Received BGP UPDATE:
Withdrawn Length = 0
Total Path Attr Length = 96
Flag: 0x90 Type: 14 Len: 44 Multiprotocol Reachable NLRI:
Address Family EVPN
NextHop len 4 NextHop 4.4.4.4
Type: EVPN-MAC Len: 33 RD: 4.4.4.4:1 ESI: ESI-0, tag: 0, mac len: 48 mac:
00:ca:fe:ca:fe:04, IP len: 0, IP: NULL, label: 1
Flag: 0x40 Type: 1 Len: 1 Origin: 0
Flag: 0x40 Type: 2 Len: 0 AS Path:
Flag: 0x80 Type: 4 Len: 4 MED: 0
Flag: 0x40 Type: 5 Len: 4 Local Preference: 100
Flag: 0xc0 Type: 16 Len: 24 Extended Community:
target:1234:1
bgp-tunnel-encap:VXLAN
mac-mobility:Seq:0/Static
--{ [FACTORY] + candidate shared default }--[ ]--
A:dut3# show network-instance MAC-VRF-1 bridge-table mac-table all
-----
-

```

```

Mac-table of network instance MAC-VRF-1
-----
-
+-----+-----+-----+-----+-----+-----+-----+
| Address      | Destination          | Dest Index | Type      | Active | Aging | Last Update |
+-----+-----+-----+-----+-----+-----+-----+
| 00:CA:FE:CA: | vxlan-interface:vxlan1.1 | 2787792288 | evpn-static | true  | N/A   | 2021-02-16T11:
| FE:04        | vtep:4.4.4.4 vni:1     | 38         |             |       |       | 10:27.000Z  |
+-----+-----+-----+-----+-----+-----+
+
Total Irb Macs      : 0 Total 0 Active
Total Static Macs   : 0 Total 0 Active
Total Duplicate Macs : 0 Total 0 Active
Total Learnt Macs   : 0 Total 0 Active
Total Evpn Macs     : 0 Total 0 Active
Total Evpn static Macs : 1 Total 1 Active
Total Irb anycast Macs : 0 Total 0 Active
Total Macs          : 1 Total 1 Active
-----
--{ [FACTORY] + candidate shared default }--[

```

Note that the static MACs state depends on the state of the subinterface which they are configured against. If the subinterface goes oper-down, the static MAC and EVPN route are removed. Static Blackhole MACs (where the configured destination is "blackhole") also behave as static MACs and are advertised as "evpn-static".

5.3.4.3 MAC loop protection

MAC loop protection in EVPN BDs is based on the SR Linux MAC Duplication feature. This feature detects MAC duplication for MACs moving:

- among bridge sub-interfaces of the same MAC-VRF
- between bridge sub-interfaces and EVPN (in the same MAC-VRF)

It does not detect MAC duplication for MACs moving from one VTEP to a different VTEP in the same MAC-VRF. In addition, when a MAC is declared as a duplicate:

- If the blackhole configuration option is added to the interface, incoming frames on bridged sub-interfaces are discarded if their MAC SA or DA match the blackhole MAC. Frames encapsulated in VXLAN packets are discarded if their inner source MAC or destination MAC match the blackhole MAC in the mac-table.
- The "duplicate" MAC can be overwritten by a higher priority type (for example, static or evpn-static) or flushed by a tools command. Blackhole MACs that result out of duplicate MACs are advertised as regular MACs (non-static).

5.4 Multi-homing configuration for EVPN broadcast domains

SR Linux supports all-active multi-homing for multi-homed peers connected using VXLAN, as per [RFC8365].

Using [Figure 6: Example of EVPN-VXLAN broadcast domain](#) as a reference, LEAF-2 and LEAF-3 are multi-homed to server-1 using all-active multi-homing. The representation of the multi-homed device in the EVPN control plane is referred to as an Ethernet Segment (ES). It is considered "all-active" and not "active-active", because SR Linux supports up to four leaf routers multi-homed to the same CE or server with all links being active (not just two).

The all-active multi-homing function relies on three different procedures to handle multi-homing in the ES:

- Designated Forwarder (DF) election
- Split-Horizon (also known as Local-Bias)
- Aliasing

The DF is the leaf that forwards BUM traffic received from the VXLAN into the ES (to the server). Only one DF can exist per ES at a time, and it is elected based on the exchange of ES routes (EVPN routes type 4) and the subsequent DF election algorithm. All leaf routers, DF and non-DF, forward known-unicast traffic to the multi-homed server.

The split-horizon or local bias is the procedure that avoids looped packets on the server. If server-1 hashes the BUM traffic to the non-DF leaf (for example, LEAF-2), without any split-horizon technique, the flooded BUM packets move to the DF (LEAF-4) and back to server-1. Split-horizon prevents these flooded packets from forwarding back to server-1. When the data plane is VXLAN, the split-horizon mechanism is based on a "local-bias" forwarding mode as defined in RFC8365. This implies that:

- BUM traffic from a local subinterface is always forwarded to the ES, irrespective of the PE being DF. For example, if HOST-2 sends a broadcast frame, it is sent to the ES (lag1.1) even though LEAF- is non-DF for ES-1.
- BUM traffic received over VXLAN is never be forwarded to the ES if the source VTEP matches a leaf that is attached to the same ES. For example, BUM traffic from HOST-2 that is forwarded via VXLAN to LEAF-4 is not forwarded to lag1.1, only to Ethernet-1/13.1.

Aliasing is the procedure that allows ecmp (load-balancing) from remote leaf routers (LEAF-3) to all leaf routers attached to the same ES, even though the MAC is only advertised by one of the leaf routers in the ES. For example, in [Figure 6: Example of EVPN-VXLAN broadcast domain](#), flows from 00:00:00:00:00:01 can only be hashed to LEAF-2. LEAF-2 is the only router in the ES advertising the MAC. However, because LEAF-2 and LEAF-4 advertise the association to the same Ethernet Segment Identifier (ESI), and the MAC/IP route for 00:00:00:00:00:01 is tagged with ESI-1, LEAF-3 can "alias" the unicast traffic to both leaf routers.

Note that a leaf advertises its association to an ES via AD per ES routes, and its association to an ES for a specified MAC-VRF via AD per EVI routes. Both are EVPN routes type 1.

5.4.1 All-active multi-homing configurations

Configuration of all-active multi-homing involves four major steps:

- Configuring the server/CE with a single LAG that connects it to the leaf routers.
- Configuring an ES (ES-1) on the leaf routers (LEAF-2 and LEAF-4)
- Associating the ES interface with the MAC-VRF.
- Optional: Configuring the ecmp with a value greater than 1 in all the leaf routers attached to the same BD (for aliasing). This step is only required if multi-homing is used in an EVPN-VXLAN BD distributed among multiple leaf routers.

5.4.1.1 Ethernet segment configuration details

With SR Linux, ESs are control plane entities that reside in the system network-instance. The system network-instance contains a BGP-VPN instance similar to the one in mac-vrfs. This instance hosts the bgp information used by EVPN for multi-homing routes, and the ES configuration and state.

The following example provides ES configuration details.

```
--{ [FACTORY] + candidate shared default }--
[ system network-instance protocols evpn ethernet-segments ]--
A:dut4# tree detail
ethernet-segments!+  evpn_mgr
+-- timers          evpn_mgr
|  +-- boot-timer?  evpn_mgr
|  +-- activation-timer?  evpn_mgr
+-- bgp-instance* [id]  evpn_mgr
    +-- ethernet-segment* [name]  evpn_mgr
        +-- admin-state?  evpn_mgr
        +-- esi?          evpn_mgr
        +-- interface?    evpn_mgr
        +-- multi-homing-mode?  evpn_mgr
        +-- df-election   evpn_mgr
            +-- timers    evpn_mgr
                +-- activation-timer?  evpn_mgr
```

The ES model uses a BGP-VPN instance where the route-distinguisher and export/import route-targets are taken by BGP and used for the ES routes. Only one instance is allowed, and all ESs live under this BGP instance. The default route-distinguisher for the instance is automatically derived from system-ip:0 and used in ES routes.

The default import/export route-target is automatically derived from the ESI (bytes 1 to 6; from the second highest order byte up to the seventh byte). This route-target is of type ESI-import route-target (as per [RFC7432]) and is used in ES routes to ensure they are imported on Leaf routers attached to the ES.

ESs have an admin-state this is disabled by default. It must be toggled to change any of the parameters affecting the EVPN control plane.

The following timers can be configured for ESs: general boot, per ES boot, and activation:

- The boot-timer is configured globally for all ESs. This allows the system to synchronize with the rest of the network at reboot, and before the ES is brought up and its route is advertised.
- Before a boot-timer expires, the ES subinterfaces are oper-up and the AD routes advertised. In all-active mode, they forward unicast traffic; BUM is not forwarded until the ES subinterfaces become DF. When the boot-timer expires, the ES route is advertised, and the DF election takes place.
- The boot-timer can be configured with a value of 0-6000 seconds. Because it is linked to the evpn_mgr application, the boot-timer kicks in when the evpn_mgr restarts. It is recommended that you configure a timer that is long enough for the node to establish its BGP sessions and underlay connectivity before it expires, use some transient BUM duplication), and ES routes are exchanged.
- The ES activation timer allows collecting ES routes for the same ES from other leaf routers before promoting a node subinterface as DF. This prevents multiple transient DF leaf routers on the same ES, and BUM duplication to the server/CE. The ES activation timer defaults to 3 seconds, but can be set to 0 if fast convergence is needed (although this may cause some transient BUM duplication).

The ES requires a manual 10-byte ESI configuration. Reserved ESI values such as ESI-0 or MAX-ESI (0xFF..FF) are not allowed. ESI values with 00-00-00-00-00-00 in bytes 1-6 are not allowed. This prevents the auto-derivation of ESI-import route-targets as all 0s.

SR Linux supports the default DF election algorithm, as per [RFC8584]. No configuration is required.

- The algorithm (also known as type Default or type 0) is a modulo-based operation that uses the number of leafs in the ES and the configured EVI values in the contained mac-vrfs.
- The default alg orders the candidate list from lowest to highest IP address (where the IP address is taken from the originating-ip of the ES routes), and picks up an ordinal of the list based on the outcome of the modulo operation.
- If the mac-vrf instances in the ES have consecutive EVI values, load balancing of the DF function occurs. For example, if mac-vrf-1 has a value of EVI=1, mac-vrf-2 is EVI=2. Both have subinterfaces in lag1 that belong to ES-1; one of the mac-vrfs is DF and the other is non-DF for ES-1.

The ES association to an interface must be configured. The interface type can be Ethernet or LAG. If LACP is used on the CE, as shown in [Figure 6: Example of EVPN-VXLAN broadcast domain](#), only a LAG can be associated.

5.4.2 Configuring LEAF-2 and LEAF-4 as multi-homed nodes to server-1

About this task

LEAF-2 and LEAF-4 behave as a single system to server-1. Therefore, they must be configured with the same LACP parameters for the LAG on server-1 to come up. The admin-key, system-id-mac, and system-priority must match on both leaf routers so that the LAG comes up.

Procedure

- Step 1.** In candidate mode, configure the LAG that connects to server-1.
The LAG can be LACP enabled or static. In this example, LACP is used.

Example

LAG configuration (LAG1 on LEAF-4)

```
--{ [FACTORY] + candidate shared default }--[ ]--
A:dut4# interface ethernet-1/4
--{ [FACTORY] + candidate shared default }--[ interface ethernet-1/4 ]--
A:dut4# info
    description ES-1
    ethernet {
        aggregate-id lag1
    }
--{ [FACTORY] + candidate shared default }--[ interface ethernet-1/4 ]--
A:dut4# /interface lag1
--{ [FACTORY] + candidate shared default }--[ interface lag1 ]--
A:dut4# info
    admin-state enable
    vlan-tagging true
    subinterface 1 {
        type bridged
        vlan {
            encap {
                single-tagged {
                    vlan-id 1
                }
            }
        }
    }
    lag {
        lag-type lacp
```

```

        member-speed 100G
        lacp {
            interval FAST
            lacp-mode ACTIVE
            admin-key 24
            system-id-mac 00:00:00:00:00:24
            system-priority 24
        }
    }
--{ [FACTORY] + candidate shared default }--[ interface lag1 ]--

```

Example

LAG configuration (LAG1 on LEAF-2)

```

--{ [FACTORY] + candidate shared default }--[ interface ethernet-1/11 ]--
A:dut2# info
    description ES-1
    ethernet {
        aggregate-id lag1
    }
--{ [FACTORY] + candidate shared default }--[ interface ethernet-1/11 ]--
A:dut2# /interface lag1
--{ [FACTORY] + candidate shared default }--[ interface lag1 ]--
A:dut2# info
    admin-state enable
    vlan-tagging true
    subinterface 1 {
        type bridged
        vlan {
            encap {
                single-tagged {
                    vlan-id 1
                }
            }
        }
    }
}
lag {
    lag-type lacp
    member-speed 100G
    lacp {
        interval FAST
        lacp-mode ACTIVE
        admin-key 24
        system-id-mac 00:00:00:00:00:24
        system-priority 24
    }
}

```

Step 2. Configure Ethernet Segment (ES-1) on LEAF-2 and LEAF-4.

See [Ethernet segment configuration details](#) for an in-depth overview of ES functionality and configuration.

Example

ES configuration (ES-1 on LEAF-2)

```

--{ [FACTORY] + candidate shared default }--[ interface lag1 ]--
A:dut2# /system network-instance
--{ [FACTORY] + candidate shared default }--[ system network-instance ]--
A:dut2# info
    protocols {
        evpn {

```

```

    ethernet-segments {
      bgp-instance 1 {
        ethernet-segment ES-1 {
          admin-state enable
          esi 01:24:24:24:24:24:00:00:01
          interface lag1
          multi-homing-mode all-active
        }
      }
    }
  }
  bgp-vpn {
    bgp-instance 1 {
    }
  }
}

```

The ESI and mode must match on both Leaf routers. The following is the minimum configuration for ES-1 to function across the two leaf routers.

Example

ES configuration (ES-1 on LEAF-4)

```

--{ [FACTORY] + candidate shared default }--[ interface lag1 ]--
A:dut4# /system network-instance
--{ [FACTORY] + candidate shared default }--[ system network-instance ]--
A:dut4# info
  protocols {
    evpn {
      ethernet-segments {
        bgp-instance 1 {
          ethernet-segment ES-1 {
            admin-state enable
            esi 01:24:24:24:24:24:00:00:01
            interface lag1
            multi-homing-mode all-active
          }
        }
      }
    }
  }
  bgp-vpn {
    bgp-instance 1 {
    }
  }
}

```

Step 3. Configure the association of the ES interface with the MAC-VRF.

In this example, interface lag1.1 is added to the MAC-VRF. The association is based on the configuration under the ES and no further configuration is needed at the MAC-VRF level.

Example

ES interface association with the MAC-VRF

```

A:dut2# /network-instance MAC-VRF-1
--{ [FACTORY] + candidate shared default }--[ network-instance MAC-VRF-1 ]--
A:dut2# info
  type mac-vrf
  admin-state enable
  interface ethernet-1/12.1 {
  }
  interface lag1.1 {
  }
}

```

```

}
vxlan-interface vxlan1.1 {
}
protocols {
  bgp-evpn {
    bgp-instance 1 {
      admin-state enable
      vxlan-interface vxlan1.1
      evi 1
    }
  }
  bgp-vpn {
    bgp-instance 1 {
      route-target {
        export-rt target:1234:1
        import-rt target:1234:1
      }
    }
  }
}
A:dut4# /network-instance MAC-VRF-1
--{ [FACTORY] + candidate shared default }--[ network-instance MAC-VRF-1 ]--
A:dut4# info
type mac-vrf
admin-state enable
interface ethernet-1/13.1 {
}
interface lag1.1 {
}
vxlan-interface vxlan1.1 {
}
protocols {
  bgp-evpn {
    bgp-instance 1 {
      admin-state enable
      vxlan-interface vxlan1.1
      evi 1
    }
  }
  bgp-vpn {
    bgp-instance 1 {
      route-target {
        export-rt target:1234:1
        import-rt target:1234:1
      }
    }
  }
}
bridge-table {
  static-mac {
    mac 00:CA:FE:CA:FE:04 {
      destination ethernet-1/13.1
    }
  }
}
}

```

Step 4. Configure the `ecmp` with a value greater than 1 in all the leaf routers attached to the same BD to allow for aliasing.

**Note:**

This step is only required if Multi-Homing is used in an EVPN-VXLAN BD distributed among multiple Leaf routers. If the Multi-Homing ES is used locally as a Layer-2 MLAG (Multi-chassis Link Aggregation Group) technique, this step can be skipped.

In the following example, LEAF-3 is configured with `ecmp 2`.

Example

Configure `ecmp`

```
--{ [FACTORY] + candidate shared default }--[ network-instance MAC-VRF-1 ]--
A:dut3# info detail flat | grep ecmp
set / network-instance MAC-VRF-1 protocols bgp-evpn bgp-instance 1 ecmp 2
```

Step 5. Review the configuration and commit the changes.

Example

```
A:dut2# commit stay
--{ candidate shared default }--[ ]--
```

5.4.2.1 Use of multi-homing as all-active MLAG for non-EVPN layer-2 BDs

An example of ESs in a non-EVPN layer-2 BD is shown in the following diagram. In this scenario, EVPN only runs locally between the leaf routers of the two pairs, but not globally in the network. The two leaf tiers (LEAF-4/5 and LEAF-2/3) are connected via layer-2 sub-interfaces, and not VXLAN. Each leaf is configured with two ESs. LEAF-4 is configured with ES-6 for multi-homing to server-6, and ES-45 for multi-homing to the LEAF-2/3 tier. The configuration of the ES previously described also apply to these topologies, with the exception that each ES would use a different name, ESI, and lag interface.

As noted in the multi-homing configuration procedure, configuring the `ecmp` with a value greater than 1 in all the leaf routers attached to the same BD is not required if the multi-homing ES is used locally as a layer-2 MLAG.

Figure 7: Use of ES for layer-2 MLAG scenarios

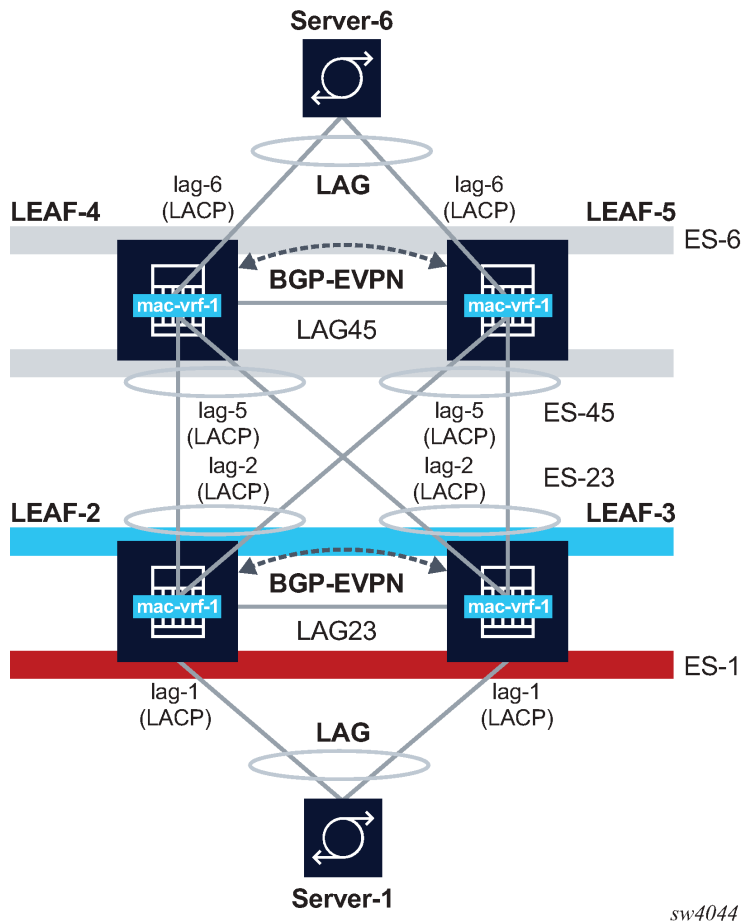

sw4044

5.4.3 Checking the multi-homing operation

After the multi-homed leaf routers and the remote leaf are configured, the ES operation must be checked.

5.4.3.1 Checking the ES status

Procedure

Use the following to check the status of the ES on LEAF-2 and LEAF-4. The output from this command must show the same DF for the same mac-vrf on both leaf routers, and the same candidate list for the ES on both leaf routers. The detail form of this command also provides information about timers and the DF election.

Example: Check the ES status

```
// Leaf-4
--{ [FACTORY] + candidate shared default }--[ ]--
A:dut4# show system network-instance ethernet-segments ES-1
-----
```

```

ES-1 is up, all-active
  ESI : 01:24:24:24:24:24:00:00:01
  Alg : default
  Peers: 2.2.2.2
  Interface: lag1
  Network-instances:
    MAC-VRF-1
      Candidates : 2.2.2.2, 4.4.4.4 (DF)
      Interface : lag1.1
-----
Summary
  1 Ethernet Segments Up
  0 Ethernet Segments Down
-----
--{ [FACTORY] + candidate shared default }--[ ]--
A:dut4# show system network-instance ethernet-segments ES-1 detail
=====
Ethernet Segment
=====
Name                : ES-1
4.4.4.4 (DF)
Admin State         : enable           Oper State           : up
ESI                 : 01:24:24:24:24:24:00:00:01
Multi-homing        : all-active       Oper Multi-homing    : all-active
Interface           : lag1
ES Activation Timer : None
DF Election         : default          Oper DF Election     : default
Last Change         : 2021-02-15T11:07:01.412Z
=====
MAC-VRF   Actv Timer Rem   DF
ES-1      0                Yes
-----
DF Candidates
-----
Network-instance   ES Peers
MAC-VRF-1          2.2.2.2
MAC-VRF-1          4.4.4.4 (DF)
=====
--{ [FACTORY] + candidate shared default }--[ ]--
// Leaf-2

--{ [FACTORY] + candidate shared default }--[ ]--
A:dut2# show system network-instance ethernet-segments ES-1
-----
ES-1 is up, all-active
  ESI : 01:24:24:24:24:24:00:00:01
  Alg : default
  Peers: 4.4.4.4
show system network-instance ethernet-segments ES-1
  Network-instances:
    MAC-VRF-1
      Candidates : 2.2.2.2, 4.4.4.4 (DF)
      Interface : lag1.1
-----
Summary
  1 Ethernet Segments Up
  0 Ethernet Segments Down
-----
--{ [FACTORY] + candidate shared default }--[ ]--

```

5.4.3.2 Checking ES and EVI routes

Procedure

The exchange of ES routes (used for DF election and ES discovery) and AD per ES/EVI routes (used to indicate the association of Leaf services to ES) can be checked with the following commands.

Note that LEAF-2 should have a type 4 route for the ES originating from LEAF-4. There should also be one AD per EVI and one AD per ES route from LEAF-4 for MAC-VRF-1. AD routes are advertised for each MAC-VRF that are part of the ES.

Example: Check ES and EVI routes

```
// Received ES routes or routes type 4 on Leaf-2
--{ [FACTORY] + candidate shared default }--[ ]--
A:dut2# show network-instance default protocols bgp routes evpn route-type 4 summary
-----
Show report for the BGP route table of network-instance "default"
-----
Status codes: u=used, *=valid, >=best, x=stale
Origin codes: i=IGP, e=EGP, ?=incomplete
-----
BGP Router ID: 2.2.2.2      AS: 2222      Local AS: 2222
-----
Type 4 Ethernet Segment Routes
+-----+-----+-----+-----+-----+-----+
| Status | Route- |      ESI      | originating | neighbor | Next-Hop |
|   *   | distinguisher |                |   -router   |          |           |
+-----+-----+-----+-----+-----+-----+
| u*>   | 4.4.4.4:0 | 01:24:24:24:24:24: | 4.4.4.4     | 4.4.4.4 | 4.4.4.4 |
|       |           | 24:00:00:01       |             |         |         |
+-----+-----+-----+-----+-----+-----+
1 Ethernet Segment routes 1 used, 1 valid
-----
--{ [FACTORY] + candidate shared default }--[ ]--
A:dut2#
/* Received AD routes or routes type 1 on Leaf-2. The AD per ES route uses Eth-Tag= MAX-ET
(all FFs). */

--{ [FACTORY] + candidate shared default }--[ ]--
A:dut2# show network-instance default protocols bgp routes evpn route-type 1 summary
-----
Show report for the BGP route table of network-instance "default"
-----
Status codes: u=used, *=valid, >=best, x=stale
Origin codes: i=IGP, e=EGP, ?=incomplete
-----
BGP Router ID: 2.2.2.2      AS: 2222      Local AS: 2222
-----
Type 1 Ethernet Auto-Discovery Routes
+-----+-----+-----+-----+-----+-----+
| Status | Route- |      ESI      | Tag-ID | neighbor | Next-hop | VNI |
|   *   | distinguisher |                |         |          |           |     |
+-----+-----+-----+-----+-----+-----+
| u*>   | 4.4.4.4:1 | 01:24:24:24:24:24: | 0       | 4.4.4.4 | 4.4.4.4 | -   |
|       |           | 24:24:00:00:01     |         |         |         |     |
| u*>   | 4.4.4.4:1 | 01:24:24:24:24:24: | 4294967295 | 4.4.4.4 | 4.4.4.4 | -   |
|       |           | 24:24:00:00:01     |         |         |         |     |
+-----+-----+-----+-----+-----+-----+
2 Ethernet Auto-Discovery routes 2 used, 2 valid
-----
```

```

--{ [FACTORY] + candidate shared default }--[ ]--
--{ [FACTORY] + candidate shared default }--[ ]--
A:dut2# show network-instance default protocols bgp routes evpn route-type 1 detail
-----
Show report for the EVPN routes to network "*" network-instance "default"
-----
Route Distinguisher: 4.4.4.4:1
Tag-ID                : 0
ESI                   : 01:24:24:24:24:24:00:00:01
neighbor              : 4.4.4.4
Received paths        : 1
  Path 1: <Best,Valid,Used,>
    ESI                : 01:24:24:24:24:24:00:00:01
    Route source       : neighbor 4.4.4.4 (last modified 4h38m27s ago)
    Route preference   : No MED, LocalPref is 100
    Atomic Aggr        : false
    BGP next-hop       : 4.4.4.4
    AS Path            : i
    Communities        : [target:1234:1, bgp-tunnel-encap:VXLAN]
    RR Attributes      : No Originator-ID, Cluster-List is []
    Aggregation        : None
    Unknown Attr       : None
    Invalid Reason     : None
    Tie Break Reason   : none
-----
Route Distinguisher: 4.4.4.4:1
Tag-ID                : 4294967295
ESI                   : 01:24:24:24:24:24:00:00:01
neighbor              : 4.4.4.4
Received paths        : 1
  Path 1: <Best,Valid,Used,>
    ESI                : 01:24:24:24:24:24:00:00:01
    Route source       : neighbor 4.4.4.4 (last modified 4h38m27s ago)
    Route preference   : No MED, LocalPref is 100
    Atomic Aggr        : false
    BGP next-hop       : 4.4.4.4
    AS Path            : i
    Communities        : [target:1234:1, esi-label:0/All-Active]
    RR Attributes      : No Originator-ID, Cluster-List is []
    Aggregation        : None
    Unknown Attr       : None
    Invalid Reason     : None
    Tie Break Reason   : none
-----
--{ [FACTORY] + candidate shared default }--[ ]--

```

5.4.3.3 Checking the MAC/IP route

Procedure

MAC/IP routes advertised for MACs learned on the ES sub-interfaces are advertised with the ESI of ES-1. The RIB state for the MAC/IP routes can be used to check this. The following command checks the MAC/IP route for MAC 00:00:00:00:00:01 on LEAF-3:

Example: Check the MAC/IP route

```

--{ [FACTORY] + candidate shared default }--[ ]--
A:dut3# show network-instance default protocols bgp routes evpn route-type 2 summary
-----
Show report for the BGP route table of network-instance "default"
-----

```

```

Status codes: u=used, *=valid, >=best, x=stale
Origin codes: i=IGP, e=EGP, ?=incomplete
-----
BGP Router ID: 3.3.3.3      AS: 3333      Local AS: 3
-----
Type 2 MAC-IP Advertisement Routes
-----
| Status | Route-dis- | Tag | MAC-address | IP- | neighbor | Next-Hop | VNI | ESI | MAC | |
| | tinguisher | -ID | | address | | | | | | |
|=====|=====|=====|=====|=====|=====|=====|=====|=====|=====|
| u*> | 2.2.2.2:1 | 0 | 00:00:00:00:00:02 | 0.0.0.0 | 2.2.2.2 | 2.2.2.2 | 1 | 00:00:00:00:00:00:00:00:00:00:00:00:00 | - |
| u*> | 4.4.4.4:1 | 0 | 00:00:00:00:00:01 | 0.0.0.0 | 4.4.4.4 | 4.4.4.4 | 1 | 01:24:24:24:24:24:24:24:24:24:24:24:24 | - |
| u*> | 4.4.4.4:1 | 0 | 00:00:00:00:00:04 | 0.0.0.0 | 4.4.4.4 | 4.4.4.4 | 1 | 00:00:00:00:00:00:00:00:00:00:00:00:00 | - |
| u*> | 4.4.4.4:1 | 0 | 00:CA:FE:CA:FE:04 | 0.0.0.0 | 4.4.4.4 | 4.4.4.4 | 1 | 00:00:00:00:00:00:00:00:00:00:00:00:00 | Seq:0/Static |
|=====|=====|=====|=====|=====|=====|=====|=====|=====|=====|
4 MAC-IP Advertisement routes 4 used, 4 valid
-----
--{ [FACTORY] + candidate shared default }--[ ]--

```

5.4.3.4 Checking the ES destination

Procedure

When AD routes are received from LEAF-2 and LEAF-4, and the MAC/IP route is tagged with the ESI, LEAF-3 creates an ES destination resolved to as many VTEPs as leafs advertising the AD routes (up to a maximum of the ecmp setting on LEAF-3). Use the following to check the ES destination for ES-1 created on LEAF-3.

Example: Check the ES destination

```

--{ [FACTORY] + candidate shared default }--[ ]--
A:dut3# show tunnel-interface vxlan1 vxlan-interface 1 bridge-table unicast-destinations destination *
-----
Show report for vxlan-interface vxlan1.1 unicast destinations
-----
Destinations
-----
| VTEP Address | Egress VNI | Destination-index | Number MACs (Active/Failed) |
|=====|=====|=====|=====|
| 2.2.2.2 | 1 | 278779228840 | 1(1/0) |
| 4.4.4.4 | 1 | 278779228838 | 2(2/0) |
|=====|=====|=====|=====|
Ethernet Segment Destinations
-----
| ESI | Destination-index | VTEPs | Number MACs (Active/Failed) |
|=====|=====|=====|=====|
| 01:24:24:24:24:24:24:00:00:00:01 | | 2.2.2.2, 4.4.4.4 | 0(0/0) |
|=====|=====|=====|=====|
Summary
3 unicast-destinations, 2 non-es, 1 es
3 MAC addresses, 3 active, 0 non-active

```

```
-----
--{ [FACTORY] + candidate shared default }--[ ]--
```

5.4.3.5 Checking MAC programming

Procedure

The following command shows how LEAF-3 programs the MACs received for the ES as associated with an ES destination

Example: Check MAC programming

```
-----
--{ [FACTORY] + candidate shared default }--[ ]--
A:dut3# show network-instance MAC-VRF-1 bridge-table mac-table mac 00:00:00:00:00:01
-----
Mac-table of network instance MAC-VRF-1
-----
Mac                : 00:00:00:00:00:01
Destination        : vxlan-interface:vxlan1.1 esi:01:24:24:24:24:24:24:00:00:01
Dest Index         : 278779228850
Type               : evpn
Programming Status : Success
Aging              : N/A
Last Update        : 2021-02-16T15:51:09.000Z
Duplicate Detect time : N/A
Hold down time remaining: N/A
-----
--{ [FACTORY] + candidate shared default }--[ ]--
```

5.4.3.6 Checking subinterface ES association (LEAF-2)

Procedure

On the non-DF (in this example, LEAF-2), the MAC-VRF interface included in ES-1 (lag1.1) shows the "multicast-forwarding" flag as none. This means that the interface does not forward BUM traffic to the CE/ server when it is received on the VXLAN. The following shows how the state for the subinterface itself shows the association with ES-1 and the DF state:

Example: Check subinterface ES association (LEAF-2)

```
-----
--{ [FACTORY] + candidate shared default }--[ ]--
A:dut2# info from state network-instance MAC-VRF-1 interface lag1.1
  network-instance MAC-VRF-1 {
    interface lag1.1 {
      oper-state up
      oper-mac-learning up
      index 12
      multicast-forwarding none
    }
  }
-----
--{ [FACTORY] + candidate shared default }--[ ]--
--{ [FACTORY] + candidate shared default }--[ ]--
A:dut2# info from state interface lag1 subinterface 1 ethernet-segment-association
  interface lag1 {
    subinterface 1 {
      ethernet-segment-association {
        ethernet-segment ES-1
      }
    }
  }
-----
```

```

        es-managed true
        designated-forwarder false
    }
}

```

5.4.3.7 Checking subinterface ES association (LEAF-4)

Procedure

On the DF (in this example, LEAF-4), the MAC-VRF interface in ES-1 (lag1.1) shows the "multicast-forwarding" flag as BUM. The following shows how the state for the subinterface itself shows the association with ES-1 and the DF state.

Example: Check subinterface ES association (LEAF-4)

```

--{ [FACTORY] + candidate shared default }--[ ]--
A:dut4# info from state network-instance MAC-VRF-1 interface lag1.1
  network-instance MAC-VRF-1 {
    interface lag1.1 {
      oper-state up
      oper-mac-learning up
      index 11
      multicast-forwarding BUM
    }
  }
--{ [FACTORY] + candidate shared default }--[ ]--
--{ [FACTORY] + candidate shared default }--[ ]--
A:dut4# info from state interface lag1 subinterface 1 ethernet-segment-association
  interface lag1 {
    subinterface 1 {
      ethernet-segment-association {
        ethernet-segment ES-1
        es-managed true
        designated-forwarder true
      }
    }
  }
}

```

5.4.3.8 EVPN related logs

The evpn_mgr application has logs that are triggered when the DF state changes on an ES as shown in the following example:

Example: EVPN related logs

```

[root@dut2 srlinux]#
2021-02-15T02:59:41.888505-08:00 dut2 local6|NOTI sr_evpn_mgr: evpn|1905|1905|00086|N:
BGP-EVPN attachment circuit on ethernet segment ES-1 on network instance MAC-VRF-1
and bgp instance 1 is now a non-designated forwarder.

2021-02-15T02:59:44.859295-08:00 dut2 local6|NOTI sr_evpn_mgr: evpn|1905|1905|00087|N:
BGP-EVPN attachment circuit on ethernet segment ES-1 on network instance MAC-VRF-1
and bgp instance 1 is now a designated forwarder.

```

6 EVPN-VXLAN for layer 3

The EVPN Layer 3 configuration model builds on the model for EVPN routes described in [EVPN-VXLAN for layer-2 and multi-homing](#). Understanding the concepts in the EVPN-VXLAN Layer-2 chapter is required to understand this chapter.

This chapter addresses connectivity between subnets across multiple Broadcast Domains (BDs) of the same tenant as defined in the EVPN Interface-less (IFL) model [draft-ietf-bess-evpn-prefix-advertisement]. It is based on the advertisement and processing of IP prefixes using EVPN type 5 routes. This chapter defines how CEs or servers can be multi-homed to multiple leaf nodes in an EVPN IFL network. It also describes other EVPN L3 topics such as:

- IRB subinterface extensions for EVPN-VXLAN Layer 3
- unicast routing PE-CE
- layer 3 host mobility

6.1 Applicability

The information and configuration in this chapter are based on SR Linux Release 21.6.

6.2 Overview

[Figure 8: EVPN IP-VRF domain in a multi-tenant DC](#) shows four leaf routers attached to the same tenant or IP-VRF domain. Servers are connected to different subnets and, therefore, different BDs. The leaf routers provide inter-subnet forwarding by using the EVPN IFL model as defined in [draft-ietf-bess-evpn-prefix-advertisement]. The SR Linux implementation is fully standard and third-party routers, such as LEAF-4, can be connected to the same IP-VRF domain as SR Linux routers.

Figure 8: EVPN IP-VRF domain in a multi-tenant DC

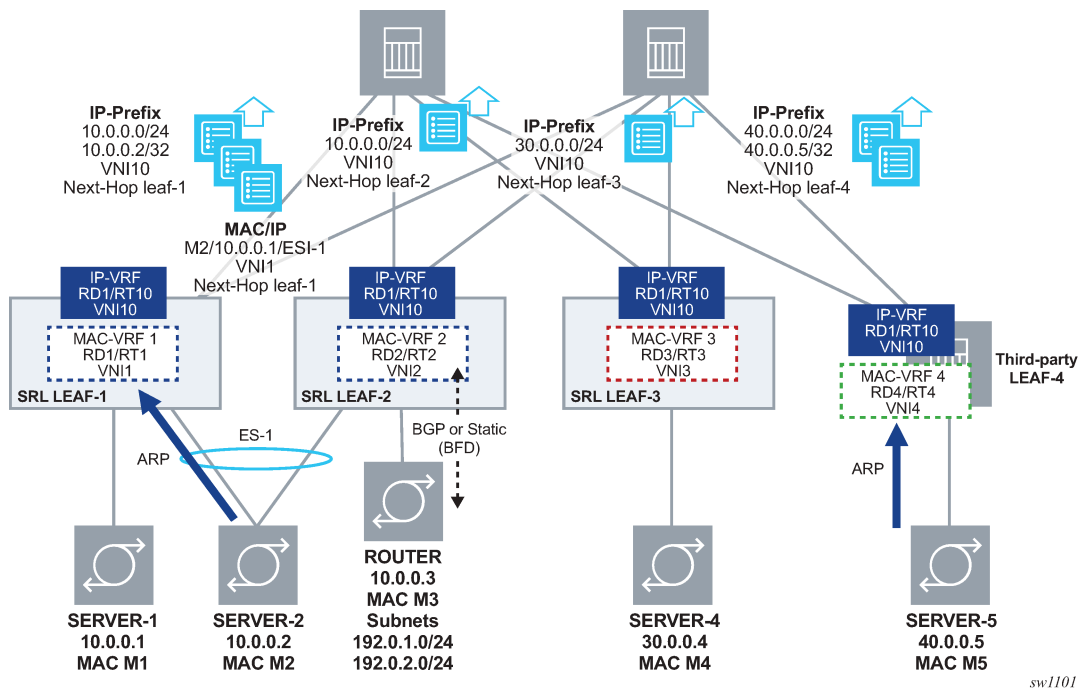

sw1101

The procedures in this chapter define the configuration and operation for:

- the EVPN IFL model for EVPN-VXLAN Layer 3 and the EVPN IP prefix routes
- multi-homing in an EVPN-VXLAN Layer 3 solution
- host route mobility aspects
- PE-CE unicast routing on EVPN-VXLAN Layer 3 networks
- EVPN-VXLAN Layer 3 feature parity for IPv6 prefixes

6.3 Configuration of EVPN-VXLAN IP-VRF domains

The following figure shows the configuration of an EVPN-VXLAN IP-VRF-10 distributed in three leaf routers, with different subnets, and multi-homing for SERVER-1.

Figure 9: Example of EVPN-VXLAN IP-VRF domain

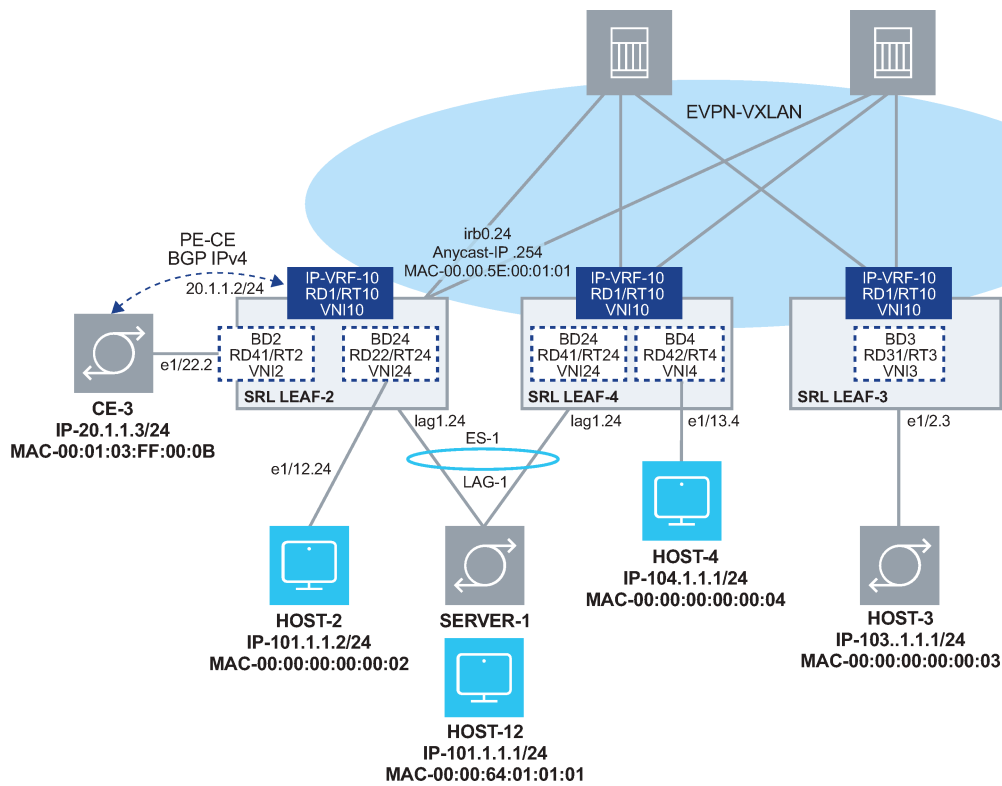

sw1102

6.3.1 Preconfiguring the underlay network

Before configuring the overlay BD, the underlay connectivity must be configured.

This chapter uses the same underlay configuration defined for EVPN-VXLAN Layer-2 and Multi-Homing. See [Configuring the underlay network](#) and review this section to understand the underlay configuration before proceeding.

6.3.2 Configuring the LEAF-3 IP-VRF domain

About this task

After LEAF-3 is pre-configured as defined in [Configuring the underlay network](#), use the following steps to enable EVPN-VXLAN on LEAF-3.

As shown in [Figure 9: Example of EVPN-VXLAN IP-VRF domain](#), LEAF-3 is attached to IP-VRF-10 and HOST-3 is connected to BD3. BD3 is mapped to subnet 103.1.1.0/24 and its IRB subinterface is the default-gateway to all hosts in BD3.

Procedure

Step 1. In candidate mode, create the interfaces and bridged subinterfaces that connect LEAF-3 BD3 to HOST-3.

In this example:

- Ethernet-1/2 connects HOST-3 to LEAF-3. Although this interface could be defined untagged, this example configures the interface as tagged (**vlan-tagging true**).
- A subinterface with index 3 is created under the interface and must be configured as **type bridged**. Bridged subinterfaces can be associated with MAC-VRF instances as described in [EVPN-VXLAN for layer-2 and multi-homing](#).
- The subinterface uses **vlan-id any**, which captures any traffic that is not specified in other subinterfaces of the same interface.



Note: The IRB subinterface expects no vlan tags so that traffic forwarded from HOST-3 can be routed. If HOST-3 sends frames tagged with a vlan-id, the frames would be classified in the BD3 context, but the subinterface does not strip off the vlan tag, and frames are not routed.

Example

```
--{ [FACTORY] + candidate shared default }--[ interface ethernet-1/2 ]--
# info
  admin-state enable
  vlan-tagging true
  subinterface 3 {
    type bridged
    admin-state enable
    vlan {
      encap {
        single-tagged {
          vlan-id any
        }
      }
    }
  }
}
```

Step 2. After creating the access subinterfaces, create the vxlan-interfaces.

This allows MAC-VRFs of the same BD to be connected throughout the IP fabric.

In this example, no other leaf router is attached to BD3, so no vxlan-interface is needed in BD3. The configuration of the vxlan-interface is only shown for completeness. See [EVPN-VXLAN for layer-2 and multi-homing](#) for details on vxlan-interfaces and their characteristics.

Example

vxlan1 vxlan-interface 3 configuration

```
--{ [FACTORY] + candidate shared default }--[ tunnel-interface vxlan1 ]--
# info
  vxlan-interface 3 {
    type bridged
    ingress {
      vni 3
    }
  }
}
```

Step 3. IP-VRF instances in the leaf routers are also connected by VXLAN tunnels, therefore, vxlan-interfaces of type routed must be created.

In this example, tunnel-interface vxlan2 vxlan-interface 10 is configured. While the configuration of the routed vxlan-interface is similar to the bridged vxlan-interface, this type ensures a routed

vxlan-interface only attaches to an ip-vrf, and a bridged vxlan-interface only attaches to a mac-vrf.

Example

VXLAN tunnel configuration

```
--{ [FACTORY] + candidate shared default }--[ tunnel-interface vxlan2 ]--
# info
  vxlan-interface 10 {
    type routed
    ingress {
      vni 10
    }
  }
```

- Step 4.** Configure the IRB interface and subinterface that links BD3 and IP-VRF-10 together to allow packets from/to subnet 103.1.1.0/24 to route to/from remote subnets in the local or remote leaf routers of the same tenant.

Note that because BD3 is not present in another leaf, the IRB subinterface is not configured as an anycast-gw subinterface. However, an operator may want to configure all IRB subinterfaces as anycast-gw in case the BD is extended later. See [Configuring the IP-VRF Domain on LEAF-2 and LEAF-4](#) for anycast-gw configuration details.

Example

IRB configuration

```
--{ [FACTORY] + candidate shared default }--[ interface irb0 ]--
# info
  subinterface 3 {
    ipv4 {
      address 103.1.1.254/24 {
      }
    }
  }
```

- Step 5.** Configure the network-instance type mac-vrf and associate it with the bridged IRB interfaces and the vxlan-interface.

In the example that follows, BD3 is connected to HOST-3 and to the IRB subinterface that is also attached to IP-VRF-10.

Although the B is not needed, in this example, the bgp-evpn and vxlan configuration is shown for completeness. For details about bgp-vpn, bgp-evpn, and vxlan-interface configuration, see [EVPN-VXLAN for layer-2 and multi-homing](#).

Example

mac-vrf configuration and bridged interface association

```
--{ [FACTORY] + candidate shared default }--[ network-instance BD3 ]--
# info
  type mac-vrf
  interface ethernet-1/2.3 {
  }
  interface irb0.3 {
  }
  vxlan-interface vxlan1.3 {
  }
  protocols {
    bgp-evpn {
    }
```

```

    bgp-instance 1 {
      admin-state enable
      vxlan-interface vxlan1.3
      evi 3
      ecmp 2
    }
  }
  bgp-vpn {
    bgp-instance 1 {
      route-target {
        export-rt target:64500:3
        import-rt target:64500:3
      }
    }
  }
}

```

Step 6. Configure IP-VRF-10 with bgp-evpn enabled using the EVPN IFL model.

In this example, IP-VRF is configured with the irb0.3 interface for connectivity to BD3 and vxlan2.10. This allows the extension of IP-VRF-10 to remote leaf routers. A loopback interface is configured in the IP-VRF to test connectivity among IP-VRFs of the same tenant.

When configured, all local routes learned on IP-VRF-10 route-table are advertised in IP Prefix routes (or IPv6 Prefix routes for local IPv6 routes).

Example

Enable EVPN IFL model on IP-VRF-10

```

--{ [FACTORY] + candidate shared default }--[ network-instance IP-VRF* ]--
# info
network-instance IP-VRF-10 {
  type ip-vrf
  interface irb0.3 {
  }
  interface lo10.2 {
  }
  vxlan-interface vxlan2.10 {
  }
  protocols {
    bgp-evpn {
      bgp-instance 1 {
        vxlan-interface vxlan2.10
        evi 10
        ecmp 2
      }
    }
    bgp-vpn {
      bgp-instance 1 {
        route-target {
          export-rt target:64500:10
          import-rt target:64500:10
        }
      }
    }
  }
}
}

```

The bgp-vpn instance is configured as described in Chapter [EVPN-VXLAN for layer-2 and multi-homing](#) (with a network-instance of type ip-vrf). Likewise, the bgp-evpn container enables EVPN in the ip-vrf and associates it to the routed vxlan-interface. The RD and RT can be auto-derived

from the evi just like they can in mac-vrfs. Explicitly configured RD/RTs can override the auto-configured ones. Import and export policies are supported.

Step 7. Review the changes. If correct, commit the changes.

Example

```
# commit stay
--{ candidate shared default }--[ ]--
```

6.3.3 Configuring the IP-VRF Domain on LEAF-2 and LEAF-4

About this task

LEAF-2 and LEAF-4 are configured in the same way as LEAF-3, but with the addition of multi-homing, anycast-gw interfaces, and related configurations.

Use the following procedure to enable EVPN-VXLAN Layer 3 on LEAF-2 and LEAF-4. Considerations for configuring the IRB subinterfaces (Step 4) are provided in [IRB subinterface considerations](#), if needed.

Procedure

Step 1. In candidate mode, create the interfaces, and bridged subinterfaces (including LAG) to connect HOST-2, HOST-4, SERVER-1, and CE-3.

In this example, Ethernet Segment ES-1 is associated with lag1 and is multi-homed to SERVER-1 lag. LACP is enabled on lag1 (but can be disabled) and the admin-key, system-id-mac, and system-priority match on both LEAF-2 and LEAF-4.

Example

Interfaces and bridged subinterfaces configuration (LEAF-2)

```
// interfaces in Leaf-2
--{ [FACTORY] + candidate shared default }--[ interface * ]--
# info
  interface ethernet-1/11 {
    description ES-1
    ethernet {
      aggregate-id lag1
    }
  }
  interface ethernet-1/12 {
    description to-host-2
    admin-state enable
    vlan-tagging true
    subinterface 24 {
      type bridged
      vlan {
        encap {
          single-tagged {
            vlan-id any
          }
        }
      }
    }
  }
  interface ethernet-1/22 {
    description to-CE-3
    vlan-tagging true
    subinterface 2 {
```

```

        type bridged
        admin-state enable
        vlan {
            encaps {
                single-tagged {
                    vlan-id 2
                }
            }
        }
    }
}
interface lag1 {
    admin-state enable
    vlan-tagging true
    subinterface 24 {
        type bridged
        vlan {
            encaps {
                single-tagged {
                    vlan-id 24
                }
            }
        }
    }
}
lag {
    lag-type lacp
    member-speed 100G
    lacp {
        interval FAST
        lacp-mode ACTIVE
        admin-key 24
        system-id-mac 00:00:00:00:00:24
        system-priority 24
    }
}
}
}

```

Example

Interfaces and bridged subinterfaces configuration (LEAF-4)

```

// Interfaces in Leaf-4
--{ [FACTORY] + candidate shared default }--[ interface * ]--
# info
interface ethernet-1/4 {
    description ES-1
    ethernet {
        aggregate-id lag1
    }
}
interface ethernet-1/13 {
    description to-host-4
    admin-state enable
    vlan-tagging true
    subinterface 4 {
        type bridged
        admin-state enable
        vlan {
            encaps {
                single-tagged {
                    vlan-id any
                }
            }
        }
    }
}
}

```



```

    }
  }
  interface lag1 {
    admin-state enable
    vlan-tagging true
    subinterface 24 {
      type bridged
      vlan {
        encaps {
          single-tagged {
            vlan-id 24
          }
        }
      }
    }
  }
  lag {
    lag-type lacp
    member-speed 100G
    lacp {
      interval FAST
      lacp-mode ACTIVE
      admin-key 24
      system-id-mac 00:00:00:00:00:24
      system-priority 24
    }
  }
}
}

```

Step 2. Create the all-active Ethernet Segment ES-1 that is attached to LEAF-2 and LEAF-4.

Details about the ES configuration and operation can be found in [EVPN-VXLAN for layer-2 and multi-homing](#). Note that the following example only shows the Ethernet Segment configuration. The `bgp-vpn>bgp-instance 1` must also be configured as described in [EVPN-VXLAN for layer-2 and multi-homing](#).

Example

ES configuration

```

// ES-1 on Leaf-2
--{ [FACTORY] + candidate shared default }--[ system network-instance protocols
evpn ethernet-segments ]--
# info
  bgp-instance 1 {
    ethernet-segment ES-1 {
      admin-state enable
      esi 01:24:24:24:24:24:00:00:01
      interface lag1
      multi-homing-mode all-active
    }
  }
// ES-1 on Leaf-4
--{ [FACTORY] + candidate shared default }--[ system network-instance protocols
evpn ethernet-segments ]--
A:dut4# info
  bgp-instance 1 {
    ethernet-segment ES-1 {
      admin-state enable
      esi 01:24:24:24:24:24:00:00:01
      interface lag1
      multi-homing-mode all-active
    }
  }
}

```

Step 3. After the access bridged subinterfaces are created, create the vxlan-interfaces to facilitate connectivity between network-instances across the IP fabric.

The mac-vrf network-instances require both vxlan-interfaces of type bridged and ip-vrfs of type routed.

In the following example, all the vxlan-interfaces for all network-instances on LEAF-2 and LEAF-4 nodes are configured as follows:

Example

vxlan-interface configuration

```
// vxlan-interfaces on Leaf-2
--{ [FACTORY] + candidate shared default }--[ tunnel-interface * ]--
# info
  tunnel-interface vxlan1 {
    vxlan-interface 2 {
      type bridged
      ingress {
        vni 2
      }
    }
    vxlan-interface 24 {
      type bridged
      ingress {
        vni 24
      }
    }
  }
  tunnel-interface vxlan2 {
    vxlan-interface 10 {
      type routed
      ingress {
        vni 10
      }
    }
  }
// vxlan-interfaces on Leaf-4
--{ [FACTORY] + candidate shared default }--[ tunnel-interface * ]--
# info
  tunnel-interface vxlan1 {
    vxlan-interface 4 {
      type bridged
      ingress {
        vni 4
      }
    }
    vxlan-interface 24 {
      type bridged
      ingress {
        vni 24
      }
    }
  }
  tunnel-interface vxlan2 {
    vxlan-interface 10 {
      type routed
      ingress {
        vni 10
      }
    }
  }
}
```

Step 4. Configure the IRB subinterfaces that link the mac-vrf and ip-vrf network-instances for inter-subnet-forwarding.

See [IRB subinterface considerations](#), for details on configuring IRB subinterfaces.

Example

IRB subinterface configuration

```
// IRB interfaces in Leaf-2
--{ [FACTORY] + candidate shared default }--[ interface irb* ]--
# info
  interface irb0 {
    subinterface 2 {
      ipv4 {
        address 20.1.1.2/24 {
        }
        arp {
          learn-unsolicited true
        }
      }
      anycast-gw {
      }
    }
    subinterface 24 {
      ipv4 {
        address 101.1.1.2/24 {
        }
        address 101.1.1.254/24 {
          anycast-gw true
          primary
        }
      }
      address 102.1.1.254/24 {
      }
      arp {
        learn-unsolicited true
        debug [
          messages
        ]
        host-route {
          populate dynamic {
          }
        }
        evpn {
          advertise dynamic {
          }
        }
      }
    }
    anycast-gw {
    }
  }
}

// IRB interfaces in Leaf-4
--{ [FACTORY] + candidate shared default }--[ interface irb* ]--
# info
  interface irb0 {
    subinterface 4 {
      ipv4 {
        address 104.1.1.4/24 {
        }
        address 104.1.1.254/24 {
          anycast-gw true
          primary
        }
      }
    }
  }
}
```

```

    }
    arp {
        learn-unsolicited true
        debug [
            messages
        ]
    }
}
anycast-gw {
}
}
subinterface 24 {
    ipv4 {
        address 101.1.1.4/24 {
        }
        address 101.1.1.254/24 {
            anycast-gw true
            primary
        }
    }
    arp {
        learn-unsolicited true
        debug [
            messages
        ]
        host-route {
            populate dynamic {
            }
        }
        evpn {
            advertise dynamic {
            }
        }
    }
}
}
anycast-gw {
}
}
}

```

Step 5. Configure the network-instances of type mac-vrf and associate the bridged subinterfaces, irb subinterfaces, and vxlan-interfaces. Then enable bgp-evpn.

Example

network instance configuration and association

```

// MAC-VRFs in Leaf-2
--{ [FACTORY] + candidate shared default }--[ network-instance BD* ]--
# info
network-instance BD2 {
    type mac-vrf
    interface ethernet-1/22.2 {
    }
    interface irb0.2 {
    }
    vxlan-interface vxlan1.2 {
    }
    protocols {
        bgp-evpn {
            bgp-instance 1 {
                admin-state enable
                vxlan-interface vxlan1.2
                evi 2
                ecmp 2
            }
        }
    }
}

```

```

    }
    bgp-vpn {
      bgp-instance 1 {
        route-target {
          export-rt target:64500:2
          import-rt target:64500:2
        }
      }
    }
  }
}
network-instance BD24 {
  type mac-vrf
  interface ethernet-1/12.24 {
  }
  interface irb0.24 {
  }
  interface lag1.24 {
  }
  vxlan-interface vxlan1.24 {
  }
  protocols {
    bgp-evpn {
      bgp-instance 1 {
        admin-state enable
        vxlan-interface vxlan1.24
        evi 24
        ecmp 2
      }
    }
    bgp-vpn {
      bgp-instance 1 {
        route-target {
          export-rt target:64500:24
          import-rt target:64500:24
        }
      }
    }
  }
}
// MAC-VRFs in Leaf-4
--{ [FACTORY] + candidate shared default }--[ network-instance BD* ]--
# info
network-instance BD24 {
  type mac-vrf
  interface irb0.24 {
  }
  interface lag1.24 {
  }
  vxlan-interface vxlan1.24 {
  }
  protocols {
    bgp-evpn {
      bgp-instance 1 {
        admin-state enable
        vxlan-interface vxlan1.24
        evi 24
        ecmp 2
      }
    }
    bgp-vpn {
      bgp-instance 1 {
        route-target {
          export-rt target:64500:24

```

```

import-rt target:64500:24
    }
  }
}
network-instance BD4 {
  type mac-vrf
  interface ethernet-1/13.4 {
  }
  interface irb0.4 {
  }
  vxlan-interface vxlan1.4 {
  }
  protocols {
    bgp-evpn {
      bgp-instance 1 {
        admin-state enable
        vxlan-interface vxlan1.4
        evi 4
        ecmp 2
      }
    }
    bgp-vpn {
      bgp-instance 1 {
        route-target {
          export-rt target:64500:4
          import-rt target:64500:4
        }
      }
    }
  }
}
}
}
}

```

Step 6. Configure IP-VRF-10 with bgp-evpn enabled with the EVPN IFL model.

The IP-VRF is configured with the IRB subinterfaces previously created for BD2, BD4, and BD24. The IP-VRF instances are connected VXLAN tunnels, so routed vxlan-interfaces need to be associated with IP-VRF-10. A loopback interface is configured in the IP-VRF to test connectivity among IP-VRFs of the same tenant.

In the following example, LEAF-2's IP-VRF is configured with a BGP PE-CE neighbor to CE-3.

Example

IP-VRF-10 configuration

```

// IP-VRF-10 in Leaf-2
--{ [FACTORY] + candidate shared default }--[ network-instance IP-VRF* ]--
# info
network-instance IP-VRF-10 {
  type ip-vrf
  interface irb0.2 {
  }
  interface irb0.24 {
  }
  interface lo10.2 {
  }
  vxlan-interface vxlan2.10 {
  }
  protocols {
    bgp-evpn {
      bgp-instance 1 {
        vxlan-interface vxlan2.10
      }
    }
  }
}

```

- **arp evpn advertise dynamic** as ARP entries do not need to be synchronized with any other node

Examples of non-distributed BDs are BD2, BD4, and BD3 as shown in [Figure 9: Example of EVPN-VXLAN IP-VRF domain](#). Their corresponding IRB subinterfaces do not create host-routes or advertise EVPN MAC/IP routes for the ARP entries.

6.3.4 Configuring EVPN IFL interoperability to EVPN IFF unnumbered model

About this task

While EVPN IFL for VXLAN is supported by most DC vendors, Nuage WBX or VSC/VRS use the EVPN IFF Unnumbered model. By default, the SR Linux EVPN IFL (interface-less) model does not inter-operate with the EVPN IFF (interface-full) model. However, it is possible to configure the SR Linux EVPN IFL model to inter-operate with the EVPN IFF model.

For more information about EVPN IFL vs EVPN IFF models, see the *SR Linux EVPN-VXLAN User Guide* and draft-ietf-bess-evpn-prefix-advertisement.

Procedure

To configure inter-operability in IP-VRF-10, configure the **advertise-gateway-mac** command as shown in the following example.

Example: EVPN IFF inter-operability in IP-VRF-10 configuration

```
--{ [FACTORY] + candidate shared default }--[ network-instance IP-VRF-10 ]--
# protocols bgp-evpn bgp-instance 1 routes route-table mac-ip advertise-gateway-mac
  <value> ?
usage: advertise-gateway-mac <true|false>
```

If set to true in an ip-vrf where bgp-evpn is enabled, a MAC/IP route containing the gateway-MAC is advertised.

This gateway-MAC matches the MAC advertised along with the EVPN IFL routes type 5 for the ip-vrf network-instance. This advertisement is needed so that the EVPN IFL (Interface-Less) model in the ip-vrf can interoperate with a remote system working in EVPN IFF (Interface-ful) Unnumbered mode.

Positional arguments:
value [true|false, default false]

When set to true, the node advertises a MAC/IP route using all of the following:

- Gateway-mac for IP-VRF-10 (that is, the system-mac)
- RD/RT, next-hop, and VNI of IP-VRF-10
- Null IP address, ESI or Ethernet Tag ID

Example: MAC/IP route advertisement

In the following example, the MAC/IP route advertised is from LEAF-3. The MAC address matches the system-mac advertised in any local RT5s.

```
--{ [FACTORY] + candidate shared default }--[ network-instance IP-VRF-10 ]--
# protocols bgp-evpn bgp-instance 1 routes route-table mac-ip advertise-gateway-mac true

--{ [FACTORY] +* candidate shared default }--[ network-instance IP-VRF-10 ]--
# commit stay
```

```

All changes have been committed. Starting new transaction.
2021-04-15T01:18:24.688185-07:00 dut3 local6|DEBU sr_bgp_mgr: bgp|4942|5135|1393922|D:
VR default (1) Peer 1: 1.1.1.1 UPDATE: Peer 1: 1.1.1.1 - Send BGP UPDATE:
  Withdrawn Length = 0
  Total Path Attr Length = 81
  Flag: 0x90 Type: 14 Len: 44 Multiprotocol Reachable NLRI:
    Address Family EVPNandidate shared default
      root (8) Thu 01:18AM
    NextHop len 4 NextHop 3.3.3.3
    Type: EVPN-MAC Len: 33 RD: 3.3.3.3:10 ESI: ESI-0, tag: 0, mac len: 48 mac:
      00:01:03:ff:00:00, IP len: 0, IP: NULL, label1: 10
  Flag: 0x40 Type: 1 Len: 1 Origin: 0
  Flag: 0x40 Type: 2 Len: 0 AS Path:
  Flag: 0x40 Type: 5 Len: 4 Local Preference: 100
  Flag: 0xc0 Type: 16 Len: 16 Extended Community:
    target:64500:10
    bgp-tunnel-encap:VXLAN

```

For IPv6, Nuage WBX devices support two EVPN L3 IPv6 modes: IFF unnumbered and IFF numbered. The SR Linux interoperability mode enabled by the `advertise-gateway-mac` command only works with devices that use EVPN IFF unnumbered. This is because EVPN IFL and EVPN IFF unnumbered models both use the same format in the IP prefix route, and differ only in the additional MAC/IP route for the gateway-mac. EVPN IFL and EVPN IFF numbered models have different IP prefix route formats, and cannot inter-operate.

6.3.5 Checking the EVPN IFL model in IP-VRFs

When configured, the state of the IP-VRF-10 on the three leaf nodes and basic connectivity should be checked.

When the leaf nodes attached to IP-VRF-10 exchange at least one EVPN IP-Prefix route on all leaf nodes of the tenant, the `bgp_mgr` requests the `fib_mgr` to create a VXLAN tunnel to each next-hop of the received EVPN routes type 5 (RT5s). This assumes the tunnel had not already been created.

When a VXLAN tunnel to the remote VTEP exists, the `bgp_mgr` requests the next-hop resolution to the `fib_mgr`, and if it resolves, the RT5 is installed in the IP-VRF route-table. Using LEAF-3 as a reference, you can check that RT5s are received from the two remote leaf nodes, and then verify that VXLAN tunnels exist to their VTEPs and the RT5s are installed in the route-table. Loopbacks are configured on each IP-VRF-10 instance to verify reachability.

6.3.5.1 Checking IP-VRF-10 state and connectivity

Procedure

The following can check RT5s for the loopbacks 22.22.22.22 and 44.44.44.44 advertised by the remote leaf nodes. You can check that the routes contain the expected IP-VRF-10 VNI, route-target, and the `mac-nh` which is used as the inner destination MAC when sending VXLAN packets to the prefix.

Example: Check IP-VRF-10 state and connectivity

```

--{ [FACTORY] + candidate shared default }--[ ]--
# show network-instance default protocols bgp routes evpn route-type 5 prefix 22.22.22/32 detail
-----
Show report for the EVPN routes in network-instance "default"
-----
Route Distinguisher: 2.2.2.2:10

```

```

Tag-ID          : 0
ip-prefix-len   : 32
ip-prefix       : 22.22.22.22/32
neighbor        : 2.2.2.2
Gateway IP      : 0.0.0.0
Received paths  : 1
  Path 1: <Best,Valid,Used,>
    ESI          : 00:00:00:00:00:00:00:00:00:00
    VNI          : 10
    Route source  : neighbor 2.2.2.2 (last modified 46m16s ago)
    Route preference: No MED, LocalPref is 100
    Atomic Aggr  : false
    BGP next-hop  : 2.2.2.2
    AS Path      : i
    Communities  : [target:64500:10, mac-nh:00:01:02:ff:00:00, bgp-tunnel-encap:VXLAN]
    RR Attributes : No Originator-ID, Cluster-List is []
    Aggregation  : None
    Unknown Attr  : None
    Invalid Reason : None
    Tie Break Reason: none
-----
--{ [FACTORY] + candidate shared default }--[ ]--
# show network-instance default protocols bgp routes evpn route-type 5 prefix 44.44.44.44/32 summary
-----
Show report for the BGP route table of network-instance "default"
-----
Status codes: u=used, *=valid, >=best, x=stale
Origin codes: i=IGP, e=EGP, ?=incomplete
-----
BGP Router ID: 3.3.3.3      AS: 3333      Local AS: 3333
-----
Type 5 IP Prefix Routes
-----+-----+-----+-----+-----+-----+-----+-----+
| Status | Route- | Tag | IP-address | neighbor | Next-Hop | VNI | Gateway |
|   | distinguisher | -ID |   |   |   |   |   |
+-----+-----+-----+-----+-----+-----+-----+-----+
| u*> | 4.4.4.4:10 | 0 | 44.44.44.44/32 | 4.4.4.4 | 4.4.4.4 | 10 | 0.0.0.0 |
+-----+-----+-----+-----+-----+-----+-----+-----+
-----
1 IP Prefix routes 1 used, 1 valid
-----
--{ [FACTORY] + candidate shared default }--[ ]--

```

6.3.5.2 Checking for VXLAN tunnel creation

Procedure

When the routes are correct, the VXLAN tunnels are created.

Example: Check for VXLAN tunnel creation

```

--{ [FACTORY] + candidate shared default }--[ ]--
# show network-instance default tunnel-table all
-----
Show report for network instance "default" tunnel table
-----
-----+-----+-----+-----+-----+-----+-----+-----+
| IPv4 Prefix | Owner | Type | Index | Metric | Preference | Fib-prog | Last Update |
+-----+-----+-----+-----+-----+-----+-----+-----+
| 2.2.2.2/32 | vxlan_mgr | vxlan | 7 | 0 | 0 | Y | 2021-04-13T10:43:09.483Z |
| 4.4.4.4/32 | vxlan_mgr | vxlan | 6 | 0 | 0 | Y | 2021-04-13T10:43:09.144Z |
+-----+-----+-----+-----+-----+-----+-----+-----+

```

```

+-----+-----+-----+-----+-----+-----+-----+-----+
2 VXLAN tunnels, 2 active, 0 inactive
-----
Show report for network instance "default" tunnel table
-----
--{ [FACTORY] + candidate shared default }--[ ]--

```

6.3.5.3 Checking for remote VTEPS and associated destinations

Procedure

The following commands show the remote VTEPs and the associated destinations. A destination is the combination of the VTEP and VNI that is created when the EVPN routes are received and the VXLAN tunnel is created. IP destinations are created from RT5s.

Example: Check for remote VTEPs and associated destinations

```

# show tunnel vxlan-tunnel vtep 2.2.2.2
-----
Show report for vxlan-tunnels vtep
-----
VTEP Address: 2.2.2.2
Index       : 202418627561
Last Change : 2021-04-13T11:47:09.000Z
-----
Destinations
-----
+-----+-----+-----+-----+
| Tunnel Interface | VXLAN Interface | Egress VNI |          Type          |
+-----+-----+-----+-----+
| vxlan1           | 1               | 1          | multicast-destination |
| vxlan2           | 10              | 10         | ip-destination        |
+-----+-----+-----+-----+
1 bridged destinations, 1 multicast, 0 unicast, 0 es
1 routed destinations
-----
--{ [FACTORY] + candidate shared default }--[ ]--
# show tunnel vxlan-tunnel vtep 4.4.4.4
-----
Show report for vxlan-tunnels vtep
-----
VTEP Address: 4.4.4.4
Index       : 202418627553
Last Change : 2021-04-14T15:40:23.000Z
-----
Destinations
-----
+-----+-----+-----+-----+
| Tunnel Interface | VXLAN Interface | Egress VNI |          Type          |
+-----+-----+-----+-----+
| vxlan1           | 1               | 1          | multicast-destination |
| vxlan1           | 1               | 1          | unicast-destination   |
| vxlan2           | 10              | 10         | ip-destination        |
+-----+-----+-----+-----+
2 bridged destinations, 1 multicast, 1 unicast, 0 es
1 routed destinations

```

```
-----
--{ [FACTORY] + candidate shared default }--[ ]--
-----
```

6.3.5.4 Checking IP-VRF-10 route table

Procedure

The following command checks the IP-VRF-10 route table to ensure all the remote subnets and hosts are received and installed. All interface and local routes are automatically advertised in RT5s. Because ECMP=2 is configured in the IP-VRF-10, there are two ECMP paths for the 101.1.1.0/24 subnet, which is attached to both LEAF-2 and LEAF-4.

Example: Check IP-VRF-10 route table

```
-----
--{ [FACTORY] + candidate shared default }--[ network-instance IP-VRF-10 ]--
# show route-table ipv4-unicast summary
-----
IPv4 Unicast route table of network instance IP-VRF-10
-----
```

Prefix	ID	Active	Route Type	Metric	Pref	Next-hop (Type)	Next-hop Interface
31.31.31.31/32	0	true	bgp-evpn	0	170	2.2.2.2 (indirect)	None
20.1.1.0/24	0	true	bgp-evpn	0	170	2.2.2.2 (indirect)	None
20.1.1.3/32	0	true	bgp-evpn	0	170	2.2.2.2 (indirect)	None
22.22.22.22/32	0	true	bgp-evpn	0	170	2.2.2.2 (indirect)	None
33.33.33.33/32	0	true	host	0	0	None (extract)	None
44.44.44.44/32	0	true	bgp-evpn	0	170	4.4.4.4 (indirect)	None
101.1.1.0/24	0	true	bgp-evpn	0	170	2.2.2.2 (indirect) 4.4.4.4 (indirect)	None
101.1.1.1/32	0	true	bgp-evpn	0	170	2.2.2.2 (indirect)	None
102.1.1.0/24	0	true	bgp-evpn	0	170	2.2.2.2 (indirect)	None
103.1.1.0/24	0	true	local	0	0	103.1.1.3 (direct)	irb0.3
103.1.1.1/32	0	true	arp-nd	0	1	103.1.1.1 (direct)	irb0.3
103.1.1.3/32	0	true	host	0	0	None (extract)	None
103.1.1.254/32	0	true	host	0	0	None (extract)	None
103.1.1.255/32	0	true	host	0	0	None (broadcast)	None
104.1.1.0/24	0	true	bgp-evpn	0	170	4.4.4.4 (indirect)	None

```
-----
15 IPv4 routes total
15 IPv4 prefixes with active routes
1 IPv4 prefixes with active ECMP routes
-----
--{ [FACTORY] + candidate shared default }--[ network-instance IP-VRF-10 ]--
-----
```

6.3.5.5 Checking route-table state for a RT5

Procedure

Use the following command to check the route-table state for a RT5. This can be useful to understand how the RT5 is resolved to a vxlan tunnel and what vxlan VNI, inner source, and destination MACs are be used when sending VXLAN packets to that route. The following uses ECMP route 101.1.1.0/24 on LEAF-3. The route's next-hop group has two separate next-hops pointing at the remote LEAF-2 and LEAF-4 VTEPs:

Example: Check route-table state for a RT5

```

--{ [FACTORY] + candidate shared default }--[ network-instance IP-VRF-10 ]--
# info from state route-table ipv4-unicast route 101.1.1.0/24 id 0
route-table {
  ipv4-unicast {
    route 101.1.1.0/24 id 0 {
      route-type bgp-evpn
      route-owner bgp_evpn_mgr
      metric 0
      preference 170
      active true
      last-app-update "a day ago"
      next-hop-group 202418627581
      resilient-hash false
      fib-programming {
        status success
      }
    }
  }
}
--{ [FACTORY] + candidate shared default }--[ network-instance IP-VRF-10 ]--
# info from state route-table next-hop-group 202418627581 next-hop *
route-table {
  next-hop-group 202418627581 {
    next-hop 0 {
      next-hop 202418627569
      resolved true
    }
    next-hop 1 {
      next-hop 202418627565
      resolved true
    }
  }
}
--{ [FACTORY] + candidate shared default }--[ network-instance IP-VRF-10 ]--
# info from state route-table next-hop 202418627569
route-table {
  next-hop 202418627569 {
    type indirect
    ip-address 2.2.2.2
    resolving-tunnel {
      ip-prefix 2.2.2.2/32
      tunnel-type vxlan
      tunnel-owner vxlan_mgr
    }
    vxlan {
      vni 10
      source-mac 00:01:03:FF:00:00
      destination-mac 00:01:02:FF:00:00
    }
  }
}

```

6.3.5.6 Monitoring pings

Procedure

The following command monitors pings between the local LEAF-3 loopback and LEAF-2's loopback (22.22.22.22), the inner source, and destination MACs that are associated to the RT5's next-hop that are

used in the actual packets. Note that the source-mac is the chassis MAC advertised in the mac-nh of the local RT5s:

Example: Monitor pings

```
--{ [FACTORY] + candidate shared default }--[ network-instance IP-VRF-10 ]--
// a ping is sent from Leaf-3 to 22.22.22.22 (the loopback on Leaf-2's IP-VRF-10)
# network-instance IP-VRF-10

--{ [FACTORY] + candidate shared default }--[ network-instance IP-VRF-10 ]--
# ping 22.22.22.22
Using network instance IP-VRF-10
PING 22.22.22.22 (22.22.22.22) 56(84) bytes of data.
64 bytes from 22.22.22.22: icmp_seq=1 ttl=64 time=4.88 ms
64 bytes from 22.22.22.22: icmp_seq=2 ttl=64 time=4.76 ms
^C
--- 22.22.22.22 ping statistics ---
2 packets transmitted, 2 received, 0% packet loss, time 1000ms
rtt min/avg/max/mdev = 4.767/4.827/4.888/0.092 ms
// the monitor command catches the inner packet sent on VXLAN
--{ [FACTORY] + candidate shared default }--[ network-instance IP-VRF-10 ]--
# /tools system traffic-monitor destination-address 33.33.33.33 protocol icmp
Running as user "root" and group "root". This could be dangerous.
Capturing on 'monit'
1      0.000000000    ethernet-1/1    00:01:02:ff:00:00    00:01:03:ff:00:00
      22.22.22.22    33.33.33.33    ICMP    146    Echo (ping) reply    id=0x580c,
      seq=1/256, ttl=64

// the source MAC is the local chassis mac:

--{ [FACTORY] + candidate shared default }--[ ]--
# info from state platform chassis mac-address
  platform {
    chassis {
      mac-address 00:01:03:FF:00:00
    }
  }

// that source MAC is also advertised in the RT5's mac-nh

--{ [FACTORY] + candidate shared default }--[ ]--
# info from state network-instance default bgp-rib evpn rib-in-out rib-out-post
ip-prefix-routes 3.3.3.3:10 ethernet-tag-id 0 ip-prefix-length 32 ip-prefix 33.33.33.33/32
neighbor 2.2.2.2
  network-instance default {
    bgp-rib {
      evpn {
        rib-in-out {
          rib-out-post {
            ip-prefix-routes 3.3.3.3:10 ethernet-tag-id 0 ip-prefix-length 32
            ip-prefix 33.33.33.33/32 neighbor 2.2.2.2 {
              esi 00:00:00:00:00:00:00:00:00:00:00:00:00:00
              gateway-ip 0.0.0.0
              vni 10
              attr-id 132
              next-hop 3.3.3.3
            }
          }
        }
      }
    }
  }
}
--{ [FACTORY] + candidate shared default }--[ ]--
```

```
# info from state network-instance default bgp-rib attr-sets attr-set rib-out index 132
network-instance default {
  bgp-rib {
    attr-sets {
      attr-set rib-out index 132 {
        origin igp
        atomic-aggregate false
        next-hop 3.3.3.3
        med 0
        local-pref 100
        aggregator {
        }
        pmsi-tunnel {
        }
        communities {
          ext-community [
            target:64500:10
            mac-nh:00:01:03:ff:00:00
            bgp-tunnel-encap:VXLAN
          ]
        }
        unknown-attributes {
        }
      }
    }
  }
}
```

The received EVPN IFL IP Prefix routes are only installed in the IP-VRF-10 route-table if:

- the import route-target matches the RT5 route-target
- the RT5's VNI matches the VNI of the vxlan-interface in the IP-VRF-10
- the RT5's gateway-ip is zero

Additional guidelines:

- Importing an RT5 into multiple ip-vrf network-instances is not supported due to the VNI restriction: an ip-vrf can only use a single VNI for ingress and egress VXLAN packets. This is a TD3 limitation.
- The route next-hop cannot be changed in ip-vrf network-instances. It is always the system-ip in this release.
- The ip-vrf bgp-evpn bgp instance can be oper-down for the same reasons as the bgp-evpn bgp instance can be down in mac-vrfs. See [EVPN-VXLAN for layer-2 and multi-homing](#) for details.
- VXLAN statistics are also accounted for when EVPN-IFL is used.
- No MTU checks are done for VXLAN in EVPN-IFL. If the routed packet plus the VXLAN overhead exceeds the underlay interface MTU of the egress interface in the default network-instance, the packet is still encapsulated and sent to the remote leaf. No statistics increment or drops occur.
- Outer TTL for VXLAN packets is always initialized to 255 and not copied or propagated from or to the inner IP packet.

6.3.6 Checking PE-CE routing on an IP-VRF with EVPN-IFL

In an EVPN-VXLAN Layer 3 network, PE-CE routing refers to the unicast routing between a CE connected to a BD in a leaf node and the IRB subinterface of the IP-VRF connected to the same BD. Static or BGP routing is supported in SR Linux. BFD can also be used between the IRB and the CE.

6.3.6.1 Checking PC-CE routing on IP-VRF

Procedure

[Figure 9: Example of EVPN-VXLAN IP-VRF domain](#) depicts a PE-CE BGP session between CE-3 and IP-VRF-10 in LEAF-2. This configuration is needed in IP-VRF-10 to enable a PE-CE BGP session to CE-3.

Example: Check PE-CE routing on IP-VRF

```
// IP-VRF-10 in Leaf-2
--{ [FACTORY] + candidate shared default }--[ network-instance IP-VRF* ]--
# info
network-instance IP-VRF-10 {
  type ip-vrf
  interface irb0.2 {
  }
  interface irb0.24 {
  }
  interface lo10.2 {
  }
  vxlan-interface vxlan2.10 {
  }
  protocols {
    bgp-evpn {
      bgp-instance 1 {
        vxlan-interface vxlan2.10
        evi 10
        ecmp 2
      }
    }
    bgp {
      admin-state enable
      afi-safi ipv4-unicast {
        admin-state enable
      }
    }
    autonomous-system 645002
    router-id 2.2.2.2
    group eBGP-PE-CE {
      admin-state enable
      export-policy export-all
      import-policy import-all
      afi-safi ipv4-unicast {
        admin-state enable
      }
    }
    neighbor 20.1.1.3 {
      peer-as 645003
      peer-group eBGP-PE-CE
      local-as as-number 645002 {
      }
      transport {
        local-address 20.1.1.2
      }
    }
  }
}
```

```

    bgp-vpn {
      bgp-instance 1 {
        route-target {
          export-rt target:64500:10
          import-rt target:64500:10
        }
      }
    }
  }
}
--{ [FACTORY] + candidate shared default }--[ network-instance IP-VRF-10 ]--
# show protocols bgp neighbor 20.1.1.3
-----
BGP neighbor summary for network-instance "IP-VRF-10"
Flags: S static, D dynamic, L discovered by LLDP, B BFD enabled, - disabled, * slow
-----
+-----+-----+-----+-----+-----+-----+-----+-----+-----+
| Net-Inst | Peer | Group | Flags | Peer-AS | State | Uptime | AFI/ | [Rx/Active |
|          |     |      |       |         |      |        | SAFI | /Tx]      |
+-----+-----+-----+-----+-----+-----+-----+-----+-----+
| IP-VRF-10 | 20.1.1.3 | eBGP-PE-CE | S | 645003 | established | 1d:21h: | ipv4- | [2/1/11] |
|          |         |            |   |         |              | 46m:56s | unicast |         |
+-----+-----+-----+-----+-----+-----+-----+-----+-----+
1 configured neighbors, 1 configured sessions are established,0 disabled peers
0 dynamic peers

```

6.3.6.2 PE-CE EBGP session: import and export policies

By default, all local routes to the IP-VRF route-table are automatically advertised in EVPN-IFL routes. This includes static routes, local routes, IGP routes, arp-nd host routes, and so on. Consider the following for routes coming from or going to a PE-CE EBGP session.

- EVPN-IFL to PE-CE EBGP: An export policy must be configured so that EVPN IFL routes can be re-advertised to a CE on the PE-CE BGP session.
- PE-CE EBGP to EVPN-IFL: Either an import policy to accept the routes or **ebgp-default-policy import-reject-all false** must be configured so that the BGP routes are re-advertised to EVPN-IFL.

For example, the following two policies are configured to import and export all routes:

Example: PE-CE EBGP session: import and export policies

```

--{ [FACTORY] + candidate shared default }--[ network-instance IP-VRF-10 ]--
# /info routing-policy policy import-all
routing-policy {
  policy import-all {
    statement 1 {
      action {
        accept {
        }
      }
    }
  }
}
--{ [FACTORY] + candidate shared default }--[ network-instance IP-VRF-10 ]--
# /info routing-policy policy export-all
routing-policy {
  policy export-all {
    statement 1 {

```

```

        action {
            accept {
            }
        }
    }
}
}

```

6.3.6.3 Additional PE-CE considerations

BGP PE-CE sessions can only be established with primary IP addresses. Therefore, in an IRB with both an anycast-gw-ip and a non-anycast-gw-ip, the BGP session can be setup against the non-anycast-gw-ip only if it is configured as primary.

A BGP session is not established if the configured BGP local-address for that session is a non-primary address. Adding a secondary address on an interface where the primary address has established a BGP session is supported.

Example: BGP PE-CE sessions and primary IP addresses

In the following, the local IP address is primary, but not an anycast-gw IP:

```

--{ [FACTORY] + candidate shared default }--[ network-instance IP-VRF-10 ]--
# /info from state interface irb0 subinterface 2
interface irb0 {
    subinterface 2 {
        admin-state enable
        ip-mtu 1500
        name irb0.2
        ifindex 1082130435
        oper-state up
        last-change "a day ago"
        ipv4 {
            allow-directed-broadcast false
            address 20.1.1.2/24 {
                anycast-gw false
                origin static
                primary
                status preferred
            }
        }
        arp {
            duplicate-address-detection true
            timeout 14400
            learn-unsolicited true
            debug [
                messages
            ]
            neighbor 20.1.1.3 {
                link-layer-address 00:01:03:FF:00:0B
                origin dynamic
                expiration-time "an hour from now"
            }
            host-route {
                populate dynamic {
                }
            }
            evpn {
            }
        }
    }
}
anycast-gw {

```

```

    virtual-router-id 1
    anycast-gw-mac 00:00:5E:00:01:01
    anycast-gw-mac-origin vrid-auto-derived
  }

```

6.3.6.3.1 Changing the route preference

Procedure

In SR Linux, the route selection across BGP families (EVPN-IFL vs PE-CE IPv4/v6) occurs based on the route-table preference. For example, if the same prefix 31.31.31.31/32 is received on the IP-VRF-10's route-table via BGP PE-CE (ipv4 family) and via EVPN-IFL, the route with the lowest route-table preference wins. By default, the preference for both EVPN-IFL and BGP PE-CE is set to 170. Therefore, for the PE-CE route to be selected, change the preference for the PE-CE routes to a value lower than 170 as shown in the following example.

Example: Changing the route preference

```

--{ [FACTORY] +* candidate shared default }--[ network-instance IP-VRF-10 ]--
# diff
    protocols {
        bgp {
            preference {
+           ebgp 160
            }
        }
    }
--{ [FACTORY] +* candidate shared default }--[ network-instance IP-VRF-10 ]--
# commit stay
All changes have been committed. Starting new transaction.
--{ [FACTORY] + candidate shared default }--[ network-instance IP-VRF-10 ]--
# show route-table ipv4-unicast prefix 31.31.31.31/32 detail
-----
IPv4 Unicast route table of network instance IP-VRF-10
-----
Destination   : 31.31.31.31/32
ID            : 0
Route Type    : bgp
Metric        : 0
Preference    : 160
Active        : true
Last change   : 2021-04-15T09:05:53.745Z
Resilient hash: false
-----
Next hops: 1 entries
20.1.1.3 (indirect) resolved by 20.1.1.3/32 (arp-nd)
  via 20.1.1.3 (direct) via [irb0.2]
-----
Destination   : 31.31.31.31/32
ID            : 1
Route Type    : bgp-evpn
Metric        : 0
Preference    : 170
Active        : false
Last change   : 2021-04-15T08:58:50.600Z
Resilient hash: false
-----
Next hops: 1 entries
3.3.3.3 (indirect) resolved by None (None)
-----

```

```
--{ [FACTORY] + candidate shared default }--[ network-instance IP-VRF-10 ]--
```

In R21.6, there is no ECMP across different owners (for instance across EVPN-IFL and PE-CE BGP), only within the same routing owner.

Note the following is *not* supported:

- BGP PE-CE is not supported on CEs that make use of Ethernet Segments, that is, EVPN Multi-Homing. This is because BGP PE-CE routes resolution using EVPN IFL routes, is blocked. The CE can still use non-EVPN multi-homing (L3 multi-homing). The CE can have a link connected to a subinterface in LEAF-1/MAC-VRF-1 and another link to a subinterface in LEAF-2/MAC-VRF-2, because MAC-VRF-1 and MAC-VRF-2 attached to different subnets.
- BGP PE-CE is not supported when the BGP session is established via VXLAN. That is, the BGP CE is connected to a leaf that is connected via vxlan to another leaf that hosts the IRB subinterface where the BGP PE session is established.

6.3.7 Checking multi-homing in an EVPN-VXLAN Layer 3 network

An EVPN-VXLAN Layer 3 network needs to provide a multi-homing solution where upstream and downstream traffic is always routed efficiently, without hair-pinning. As shown in [Figure 10: Example of EVPN-VXLAN layer 3 multi-homing](#), LEAF-2 and LEAF-4 are all-active multi-homed to SERVER-1. The use of IRB ancast-gw IP and MAC addresses, along with the synchronization of MACs and ARPs on the multi-homed leaf nodes, provides efficient routing.

Figure 10: Example of EVPN-VXLAN layer 3 multi-homing

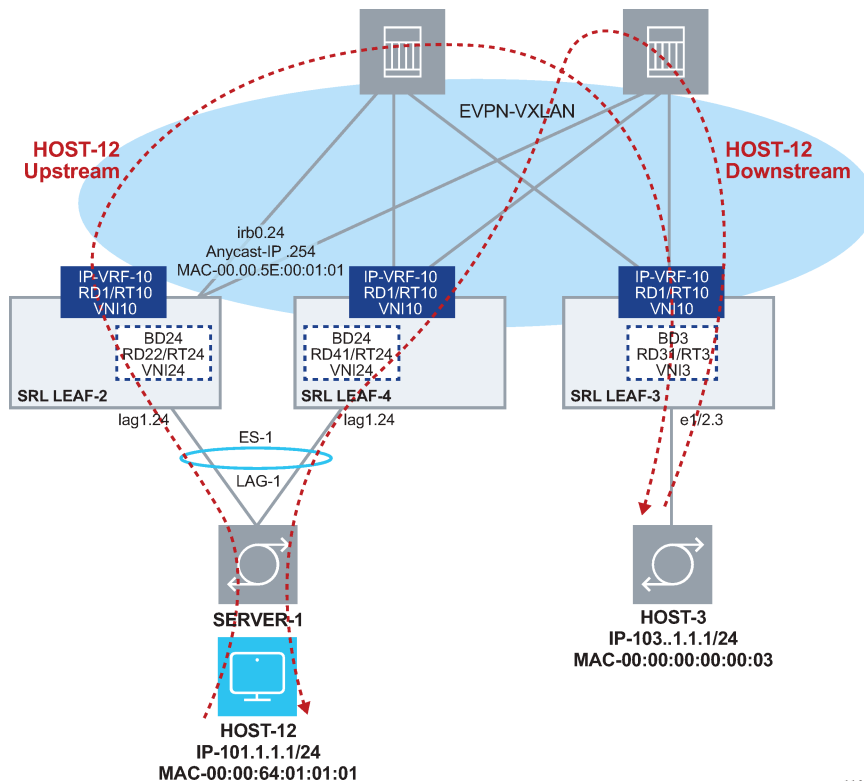

sw1103

6.3.7.1 Consistency check for anycast-gw IPs

The configuration of the anycast-gw must be consistent in the IRB sub-interfaces of LEAF-2 and LEAF-4.

6.3.7.1.1 Checking anycast-gw IP address consistency

Procedure

The consistency of the anycast-gw configuration can be checked on the state of the subinterface:

Example: Check configuration consistency

```
// Leaf-2 irb0.24 subinterface
--{ [FACTORY] + candidate shared default }--[ ]--
# info from state interface irb0 subinterface 24
  interface irb0 {
    subinterface 24 {
      admin-state enable
      ip-mtu 1500
      name irb0.24
      ifindex 1082130457
      oper-state up
      last-change "2 days ago"
      ipv4 {
        allow-directed-broadcast false
        address 101.1.1.254/24 {
          anycast-gw true
          origin static
          primary
          status preferred
        }
      }
      anycast-gw {
        virtual-router-id 1
        anycast-gw-mac 00:00:5E:00:01:01
        anycast-gw-mac-origin vrid-auto-derived
      }
    }
  }
// Leaf-4 irb.024 subinterface
--{ [FACTORY] + candidate shared default }--[ ]--
# info from state interface irb0 subinterface 24
  interface irb0 {
    subinterface 24 {
      admin-state enable
      ip-mtu 1500
      name irb0.24
      ifindex 1082130457
      oper-state up
      last-change "2 days ago"
      ipv4 {
        allow-directed-broadcast false
        address 101.1.1.254/24 {
          anycast-gw true
          origin static
          primary
          status preferred
        }
      }
      anycast-gw {
        virtual-router-id 1
        anycast-gw-mac 00:00:5E:00:01:01
        anycast-gw-mac-origin vrid-auto-derived
      }
    }
  }
```

```
}

```

The anycast-gw-mac address is automatically derived by default as 00:00:5e:00:01:VRID per draft-ietf-bess-evpn-inter-subnet-forwarding. It can also be manually configured. Either way, the anycast-gw IP and MAC must match in the two leaf nodes.

6.3.7.1.2 Checking anycast-gw IP address resolution

Procedure

In the next example, HOST-12 is configured with default-gw 101.1.1.254 (the anycast-gw IP address of BD24). When HOST-12 ARPs for the default-gw IP, the ARP Request can be hashed to either leaf. Regardless which leaf gets the ARP Request, the ARP reply contains the anycast-gw MAC. Unicast traffic from HOST-12 can now be hashed to either leaf (for example, LEAF-2 in [Figure 10: Example of EVPN-VXLAN layer 3 multi-homing](#)) and the receiving leaf node always routes the traffic directly to LEAF-3 without sending it to the peer leaf first (LEAF-4 in the example). Using no anycast-gw IPs or MAC addresses causes hair-pinning and uses unnecessary spine bandwidth.

The following shows the resolution of the anycast-gw IP from HOST-12 and upstream routed traffic.

Example: anycast-gw IP address resolution

```
[:host-12]$ arp -n -I veth2
[:host-12]$
[:host-12]$
[:host-12]$ ping 33.33.33.33
PING 33.33.33.33 (33.33.33.33) 56(84) bytes of data.
02:58:15.782587 00:00:64:01:01:01 > Broadcast, ethertype ARP (0x0806), length 42:
  Request who-has 101.1.1.254 tell 101.1.1.1, length 28

02:58:15.787404 00:00:5e:00:01:01 > 00:00:64:01:01:01, ethertype ARP (0x0806),
  length 60: Reply 101.1.1.254 is-at 00:00:5e:00:01:01, length 46

02:58:15.787436 00:00:64:01:01:01 > 00:00:5e:00:01:01, ethertype IPv4 (0x0800),
  length 98: 101.1.1.1 > 33.33.33.33: ICMP echo request, id 3140, seq 1, length 64

02:58:15.791393 00:00:5e:00:01:01 > 00:00:64:01:01:01, ethertype IPv4 (0x0800),
  length 98: 33.33.33.33 > 101.1.1.1: ICMP echo reply, id 3140, seq 1, length 64

64 bytes from 33.33.33.33: icmp_seq=1 ttl=63 time=8.96 ms

--- 33.33.33.33 ping statistics ---
9 packets transmitted, 9 received, 0% packet loss, time 8008ms
rtt min/avg/max/mdev = 2.362/3.792/8.962/1.907 ms
[:host-12]$ arp -n -i veth2
Address          HWtype  HWaddress          Flags Mask          Iface
101.1.1.254      ether   00:00:5e:00:01:01  C                   veth2
```

6.3.7.1.3 Checking synchronization in both multi-home leaf nodes

Procedure

As shown in [Figure 10: Example of EVPN-VXLAN layer 3 multi-homing](#), downstream routed traffic from LEAF-3 to HOST-12 is routed directly by LEAF-2 or LEAF-4 without hair-pinning, regardless of who gets the packets. This occurs because HOST-12's ARP and the MAC entries are synchronized in both multi-homed leaf nodes. LEAF-2 learns 101.1.1.1->00:00:64:01:01:01 (host-12 ip and mac) as dynamic and

advertises both in MAC/IP routes that are imported by LEAF-4. LEAF-4 installs the HOST-12 ARP and MAC entries as evpn. However, the MAC points at the local ES lag interface, and forwarding is direct to HOST-12.

Example: Synchronization in both multi-home leaf nodes

```
--{ [FACTORY] + candidate shared default }--[ ]--
# show arpd arp-entries interface irb0 subinterface 24
```

Interface	Subinterface	Neighbor	Origin	Link layer address	Expiry
irb0	24	101.1.1.1	dynamic	00:00:64:01:01:01	3 hours from now
irb0	24	101.1.1.4	evpn	00:01:04:FF:00:41	

```
-----
Total entries : 2 (0 static, 2 dynamic)
-----
--{ [FACTORY] + candidate shared default }--[ ]--
# show network-instance BD24 bridge-table mac-table all
```

Mac-table of network instance BD24

Address	Destination	Dest-Index	Type	Active	Aging	Last Update
00:00:5E:00:01:01	irb	0	irb-int erface- anycast	true	N/A	2021-04-13T10:42:14.000Z
00:00:64:01:01:01	lag1.24	20	learnt	true	285	2021-04-15T10:13:11.000Z
00:00:66:01:01:01	ethernet-1/12.24	17	learnt	true	285	2021-04-15T10:13:11.000Z
00:01:02:FF:00:41	irb	0	irb-int erface	true	N/A	2021-04-13T10:42:14.000Z
00:01:04:FF:00:41	vxlan-interface: vxlan1.24 vtep:4.4.4.4 vni:24	202418 653897	evpn- static	true	N/A	2021-04-13T10:42:54.000Z

```
-----
Total Irb Macs          : 1 Total 1 Active
Total Static Macs      : 0 Total 0 Active
Total Duplicate Macs   : 0 Total 0 Active
Total Learnt Macs     : 2 Total 2 Active
Total Evpn Macs       : 0 Total 0 Active
Total Evpn static Macs : 1 Total 1 Active
Total Irb anycast Macs : 1 Total 1 Active
Total Macs            : 5 Total 5 Active
-----
--{ [FACTORY] + candidate shared default }--[ ]--

// ARP and MAC entries for Leaf-4

--{ [FACTORY] + candidate shared default }--[ ]--
# show arpd arp-entries interface irb0 subinterface 24
```

Interface	Subinterface	Neighbor	Origin	Link layer address	Expiry
irb0	24	101.1.1.1	evpn	00:00:64:01:01:01	
irb0	24	101.1.1.2	evpn	00:01:02:FF:00:41	

```

Total entries : 2 (0 static, 2 dynamic)
-----
--{ [FACTORY] + candidate shared default }--[ ]--
# show network-instance BD24 bridge-table mac-table all
-----
Mac-table of network instance BD24
-----
+-----+-----+-----+-----+-----+-----+-----+
| Address          | Destination          | Dest | Type      | Active | Aging | Last Update |
| Index           |                       | Index|           |        |        |              |
+-----+-----+-----+-----+-----+-----+-----+
| 00:00:5E:00:01:01 | irb                   | 0    | irb-int  | true   | N/A   | 2021-04-13T10:42:38.000Z |
|                   |                       |      | erface-  |        |        |              |
|                   |                       |      | anycast  |        |        |              |
| 00:00:64:01:01:01 | lag1.24               | 18   | evpn     | true   | N/A   | 2021-04-15T10:04:12.000Z |
|                   |                       |      |          |        |        |              |
| 00:00:66:01:01:01 | vxlan-interface:vxlan1.24 | 202418 | evpn     | true   | N/A   | 2021-04-15T10:13:12.000Z |
|                   | vtep:2.2.2.2 vni:24    | 654989 |          |        |        |              |
| 00:01:02:FF:00:41 | vxlan-interface:vxlan1.24 | 202418 | evpn-    | true   | N/A   | 2021-04-13T10:42:54.000Z |
|                   | vtep:2.2.2.2 vni:24    | 654989 | static   |        |        |              |
| 00:01:04:FF:00:41 | irb                   | 0    | irb-int  | true   | N/A   | 2021-04-13T10:42:38.000Z |
|                   |                       |      | erface   |        |        |              |
+-----+-----+-----+-----+-----+-----+-----+
Total Irb Macs      : 1 Total 1 Active
Total Static Macs  : 0 Total 0 Active
Total Duplicate Macs : 0 Total 0 Active
Total Learnt Macs  : 0 Total 0 Active
Total Evpn Macs    : 2 Total 2 Active
Total Evpn static Macs : 1 Total 1 Active
Total Irb anycast Macs : 1 Total 1 Active
Total Macs         : 5 Total 5 Active
-----
--{ [FACTORY] + candidate shared default }--[ ]--

```

6.3.7.2 Non-anycast-gw IP addresses

In addition to using anycast-gw IPs for the routed traffic, the multi-homed leaf nodes also have non-anycast-gw IPs that can be used for ICMP. The examples that follow check the availability of each individual Leaf IRB (LEAF-2 and LEAF-4).

6.3.7.2.1 Checking LEAF-2 IRB availability

Procedure

LEAF-2 has a non-anycast-gw IP 101.1.1.2:

Example: Check LEAF-2 IRB availability

```

--{ [FACTORY] + candidate shared default }--[ network-instance IP-VRF-10 ]--
# show interfaces irb0.24
=====
Net instance      : IP-VRF-10
Interface         : irb0.24
Oper state       : up
Ip mtu           : 1500
Prefix           | Origin      | Status
=====
101.1.1.2/24     | static      | preferred
101.1.1.254/24  | static      | preferred, primary, anycast

```

```

102.1.1.254/24          static      preferred
2001:db8:24::254/64    static      preferred, primary, anycast
fe80::200:5eff:fe00:101/64 link-layer  preferred, anycast
fe80::201:2ff:feff:41/64 link-layer  preferred
=====
--{ [FACTORY] + candidate shared default }--[ network-instance IP-VRF-10 ]--

```

6.3.7.2.2 Checking LEAF-4 IRB availability

Procedure

LEAF-4 has a non-anycast-gw IP 101.1.1.4 in the same IRB:

Example: Check LEAF-4 IRB availability

```

--{ [FACTORY] + candidate shared default }--[ network-instance IP-VRF-10 ]--
# show interfaces irb0.24
=====
Net instance      : IP-VRF-10
Interface         : irb0.24
Oper state        : up
Ip mtu            : 1500
  Prefix          :
  Origin          :
  Status          :
=====
101.1.1.4/24      static      preferred
101.1.1.254/24    static      preferred, primary, anycast
fe80::200:5eff:fe00:101/64 link-layer  preferred, anycast
fe80::201:4ff:feff:41/64 link-layer  preferred
=====
--{ [FACTORY] + candidate shared default }--[ network-instance IP-VRF-10 ]--

```

6.3.7.2.3 Checking non-anycast-gw IPs reachability

Procedure

Both non-anycast-gw IPs are reachable from HOST-12. ARP Requests to non-anycast-gw IPs reply with the chassis MAC of the leaf and not with the anycast-gw MAC of the IRB. This allows using the non-anycast-gw IPs for troubleshooting purposes when there are anycast-gw IPs on the same IRBs. The example output from HOST-12 demonstrates this:

Example: non-anycast-gw IPs reachability from host

```

[:host-12]$ arp -n -i veth2
Address          HWtype HWaddress      Flags Mask      Iface
101.1.1.254      ether  00:00:5e:00:01:01 C              veth2

[:host-12]$ ping 101.1.1.2
PING 101.1.1.2 (101.1.1.2) 56(84) bytes of data.

03:25:41.291765 00:00:64:01:01:01 > Broadcast, ethertype ARP (0x0806), length 42:
Request who-has 101.1.1.2 tell 101.1.1.1, length 28

03:25:41.295105 00:01:02:ff:00:41 > 00:00:64:01:01:01, ethertype ARP (0x0806),
length 60: Reply 101.1.1.2 is-at 00:01:02:ff:00:41, length 46

03:25:41.295130 00:00:64:01:01:01 > 00:01:02:ff:00:41, ethertype IPv4 (0x0800),
length 98:101.1.1.1 > 101.1.1.2: ICMP echo request, id 3307, seq 1, length 64

```

```

03:25:41.299204 00:01:02:ff:00:41 > 00:00:64:01:01:01, ethertype IPv4 (0x0800),
  length 98: 101.1.1.2 > 101.1.1.1: ICMP echo reply, id 3307, seq 1, length 64

64 bytes from 101.1.1.2: icmp_seq=1 ttl=64 time=7.59 ms

--- 101.1.1.2 ping statistics ---
4 packets transmitted, 4 received, 0% packet loss, time 3003ms
rtt min/avg/max/mdev = 2.073/3.684/7.596/2.269 ms

[:host-12]$ arp -n -i veth2
Address                HWtype  HWaddress          Flags Mask          Iface
101.1.1.254            ether   00:00:5e:00:01:01  C                   veth2
101.1.1.2              ether   00:01:02:ff:00:41  C                   veth2
[:host-12]$ ping 101.1.1.4
PING 101.1.1.4 (101.1.1.4) 56(84) bytes of data.

03:25:52.696934 00:00:64:01:01:01 > Broadcast, ethertype ARP (0x0806), length 42:
  Request who-has 101.1.1.4 tell 101.1.1.1, length 28

03:25:52.700615 00:01:04:ff:00:41 > 00:00:64:01:01:01, ethertype ARP (0x0806),
  length 60: Reply 101.1.1.4 is-at 00:01:04:ff:00:41, length 46

03:25:52.700649 00:00:64:01:01:01 > 00:01:04:ff:00:41, ethertype IPv4 (0x0800),
  length 98: 101.1.1.1 > 101.1.1.4: ICMP echo request, id 3318, seq 1, length 64

03:25:52.703463 00:01:04:ff:00:41 > 00:00:64:01:01:01, ethertype IPv4 (0x0800),
  length 98: 101.1.1.4 > 101.1.1.1: ICMP echo reply, id 3318, seq 1, length 64

64 bytes from 101.1.1.4: icmp_seq=1 ttl=64 time=6.64 ms

--- 101.1.1.4 ping statistics ---
3 packets transmitted, 3 received, 0% packet loss, time 2003ms
rtt min/avg/max/mdev = 2.200/3.821/6.648/2.006 ms

[:host-12]$ arp -n -i veth2
Address                HWtype  HWaddress          Flags Mask          Iface
101.1.1.4              ether   00:01:04:ff:00:41  C                   veth2
101.1.1.254            ether   00:00:5e:00:01:01  C                   veth2
101.1.1.2              ether   00:01:02:ff:00:41  C                   veth2

```

6.3.7.3 Additional anycast gateway considerations

The following guidelines also apply for using anycast-gw in SR Linux.

In a bgp-evpn-enabled MAC-VRF with an IRB subinterface, the following applies whether the IPs are configured as primary, anycast-gw, or neither of these.

- All IPv4 and IPv6 addresses associated with the IRB subinterface are advertised in separate MAC/IP routes.
- The anycast-gw-mac and its corresponding anycast-gw IP address are advertised in a MAC/IP route.
- Any other existing non-anycast-gw IP is advertised along with the interface MAC (hw-mac) in a MAC/IP route.

For example, if irb0.24 is configured in LEAF-2 with anycast-gw (ip,mac)=(101.1.1.254/24, 00:5e:00:00:01:01), and 101.1.1.2/24 is also configured as non-anycast-gw IP, two MAC/IP routes are advertised in the context of BD24: MAC/IP route (101.1.1.254, 00:5e:00:00:01:01), and MAC/IP route (101.1.1.2, hw-mac-1).

For IPv6, Local Link Addresses (LLDs) are also advertised in addition to global addresses.

When the IRB subinterface is admin disabled, the IRB MAC addresses are removed from the mac-table (and withdrawn from EVPN). ARP Requests and Neighbor Solicitation messages for the IRB subinterface IP addresses from the hosts connected to the Broadcast Domain are only processed when coming from local subinterfaces. These messages cannot be processed when received over VXLAN, so each of the Leaf routers attached to the same BD need to have their anycast IRB subinterface operationally up to process the requests for the local hosts.

6.3.7.3.1 Checking protection flags per MAC address

Procedure

The IRB MAC addresses are protected in the mac-table if they are not anycast-gw-MACs. Protection means that received frames are dropped if their MAC SA match a protected MAC. The mac-table state shows the protection flag per MAC.

Example: mac-table state

```
--{ [FACTORY] + candidate shared default }--[ ]--
# info from state network-instance BD24 bridge-table mac-table mac *
network-instance BD24 {
  bridge-table {
    mac-table {
      mac 00:00:5E:00:01:01 {
        destination-type irb-interface
        destination-index 0
        type irb-interface-anycast
        last-update "2 days ago"
        destination irb
        is-protected false
      }
      mac 00:01:02:FF:00:41 {
        destination-type irb-interface
        destination-index 0
        type irb-interface
        last-update "2 days ago"
        destination irb
        is-protected true
      }
      mac 00:01:04:FF:00:41 {
        destination-type vxlan
        destination-index 202418653897
        type evpn-static
        last-update "2 days ago"
        destination "vxlan-interface:vxlan1.24 vtep:4.4.4.4 vni:24"
        is-protected true
      }
    }
  }
}
```

6.4 Testing and checking Layer 3 host mobility

In EVPN-VXLAN Layer 3 networks, multiple leaf nodes are attached to the same BD. Hosts of the same subnet can be connected to any of those leaf nodes. They can also move between leaf nodes of the

same BD. In either case, the upstream and downstream traffic must be efficient and avoid hair-pinning. This is shown in the following figure, where LEAF-2 and LEAF-4 configurations are modified (no ES) and HOST-12 was originally connected to LEAF-2.

Upstream traffic from HOST-12 to HOST-3 must be routed by LEAF-2 to LEAF-3 directly. If HOST-12 later moves to LEAF-4, upstream traffic to HOST-3 must be routed by LEAF-4 to LEAF-3 directly. This is accomplished using anycast-gw IPs and MACs on the IRB interfaces.

When HOST-12 is attached to LEAF-2, downstream traffic from HOST-3 must be sent from LEAF-3 to LEAF-2 directly. If HOST-12 later moves to LEAF-4, the routers need to update their tables quickly so that LEAF-3 routes the traffic to LEAF-4 directly, and no bandwidth is wasted on the spines because of unnecessary hair-pinning. This is achieved by learning HOST-12's IP address in the route-table of the connected leaf as a /32 route and advertising that host route in an EVPN IFL route.

Upon a mobility event to LEAF-4, LEAF-2 withdraws the host route as fast as possible and LEAF-4 then advertises the HOST-12 host route in an EVPN IFL route.

Figure 11: Example of L3 host mobility

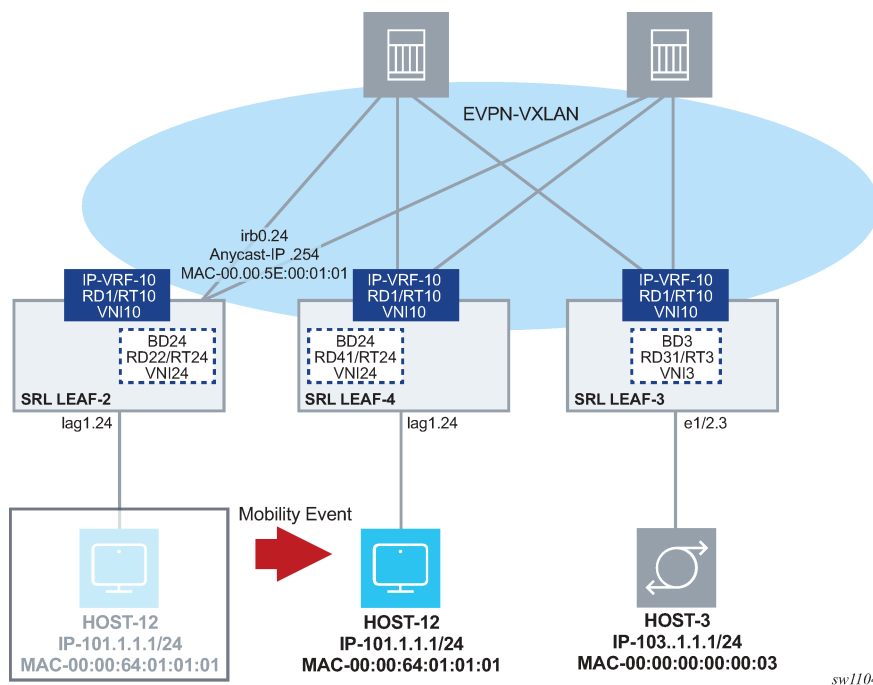

6.4.1 Configuring efficient host routing

About this task

In the initial configuration, HOST-12 is connected to LEAF-2. For LEAF-3 to route traffic (to HOST-12) directly to LEAF-2, LEAF-2 needs to learn HOST-12's IP and advertise its host route in an EVPN-IFL route.

In the next example, the following parameter definitions apply.

- **learn-unsolicited true** - Triggers the node to snoop/process all solicited and unsolicited ARP messages received on sub-interfaces (no vxlan) and learns the corresponding ARP/ND entries as

'dynamic'. By default, the command is false and only solicited entries are learned, which does not guarantee host mobility.

When enabled, dynamic ARP/ND entries are learned from the following messages received on the sub-interfaces (if the IPs fall into the local subnets):

- ARP and Neighbor Solicitation requests
- Gratuitous ARP requests and unsolicited neighbor advertisements
- **host-route populate dynamic** - Triggers the creation of arp-nd host routes in the IP-VRF-10 route-table out of dynamic ARP entries. These are disabled by default. The arp-nd host routes are *not* installed in the FIB. They are only used in the control plane and advertised to the EVPN-IFL network to attract traffic from LEAF-3. The arp-nd host routes can be exported in any routing protocol, such as EVPN-IFL routes, BGP IPv4/IPv6 routes, OSPF, and ISIS. They are supported in network-instances ip-vrf and default.
- **evpn advertise dynamic** - Triggers the advertisement of EVPN MAC/IP routes for the dynamic learned ARP entries and allows the synchronization of the ARP entries in all IRB sub-interfaces of the same BD. This is only supported on IRB sub-interfaces.

The MAC/IP routes that are advertised for ARP/ND entries contain the S bit set if the corresponding MAC entry in the mac-table is static.

Note that an equivalent command can be used for ND entries.

Example: Efficient host routing model

```
# subinterface 24
--{ [FACTORY] + candidate shared default }--[ interface irb0 subinterface 24 ]--
# info
  ipv4 {
    address 101.1.1.2/24 {
    }
    address 101.1.1.254/24 {
      anycast-gw true
      primary
    }
  }
  arp {
    learn-unsolicited true
    debug [
      messages
    ]
    host-route {
      populate dynamic {
      }
    }
  }
  evpn {
    advertise dynamic {
    }
  }
}
anycast-gw {
}
```

The next examples show how an ARP Request from HOST-12 to a random IP in the subnet is enough for the irb0.24 to learn the dynamic ARP. It can then create a host route that is advertised as an EVPN IFL route, and imported by LEAF-3.

Example: LEAF-2 - HOST-12 unsolicited ARP Request

```
--{ [FACTORY] + candidate shared default }--[ ]--
# show arpnd arp-entries interface irb0 subinterface 24
+-----+-----+-----+-----+-----+-----+
| Interface | Subinterface | Neighbor | Origin | Link layer address | Expiry |
+-----+-----+-----+-----+-----+-----+
| irb0      | 24          | 101.1.1.4 | evpn   | 00:01:04:FF:00:41 |        |
+-----+-----+-----+-----+-----+-----+
Total entries : 1 (0 static, 1 dynamic)
-----
```

Example: Debug messages - ARP request received

```
2021-04-15T04:58:05.651861-07:00 dut2 local6|INFO sr_arp_nd_mgr: arpnd|1773|1773|19334|I:
Received ARP request on interface irb0.24 (10247 - 22) from datapath. Source Mac :
00:00:64:01:01:01 Source IP : 101.1.1.1 Target Mac : 00:00:00:00:00:00 Target IP :
101.1.1.200
```

Example: Triggered learning of RT5 and RT2 advertisements

```
2021-04-15T04:58:06.019955-07:00 dut2 local6|DEBU sr_bgp_mgr: bgp|4933|5176|2128215|D:
VR default (1) Peer 1: 3.3.3.3 UPDATE: Peer 1: 3.3.3.3 - Send BGP UPDATE:
Withdrawn Length = 0
Total Path Attr Length = 85
Flag: 0x90 Type: 14 Len: 48 Multiprotocol Reachable NLRI:
Address Family EVPN
NextHop len 4 NextHop 2.2.2.2
Type: EVPN-IP-PREFIX Len: 34 RD: 2.2.2.2:10, tag: 0, ip_prefix: 101.1.1.1/32
gw_ip 0.0.0.0 Label: 10
Flag: 0x40 Type: 1 Len: 1 Origin: 0
Flag: 0x40 Type: 2 Len: 0 AS Path:
Flag: 0x80 Type: 4 Len: 4 MED: 0
Flag: 0x40 Type: 5 Len: 4 Local Preference: 100
Flag: 0xc0 Type: 16 Len: 24 Extended Community:
target:64500:10
mac-nh:00:01:02:ff:00:00
bgp-tunnel-encap:VXLAN
2021-04-15T04:58:06.020003-07:00 dut2 local6|DEBU sr_bgp_mgr: bgp|4933|5176|2128216|D:
VR default (1) Peer 1: 3.3.3.3 UPDATE: Peer 1: 3.3.3.3 - Send BGP UPDATE:
Withdrawn Length = 0
Total Path Attr Length = 97
Flag: 0x90 Type: 14 Len: 45 Multiprotocol Reachable NLRI:
Address Family EVPN
NextHop len 4 NextHop 2.2.2.2
Type: EVPN-MAC Len: 37 RD: 2.2.2.2:24 ESI: ESI-0, tag: 0, mac len: 48 mac:
00:00:64:01:01:01, IP len: 4, IP: 101.1.1.1, label: 24
Flag: 0x40 Type: 1 Len: 1 Origin: 0
Flag: 0x40 Type: 2 Len: 0 AS Path:
Flag: 0x40 Type: 5 Len: 4 Local Preference: 100
Flag: 0xc0 Type: 16 Len: 16 Extended Community:
target:64500:24
bgp-tunnel-encap:VXLAN
--{ [FACTORY] + candidate shared default }--[ ]--
# show arpnd arp-entries interface irb0 subinterface 24
+-----+-----+-----+-----+-----+-----+
| Interface | Sub-   | Neighbor | Origin | Link layer | Expiry |
|           | interface |         |        | address    |         |
+-----+-----+-----+-----+-----+-----+
| irb0      | 24     | 101.1.1.1 | dynamic | 00:00:64:01:01:01 | 3 hours from now |
| irb0      | 24     | 101.1.1.4 | evpn   | 00:01:04:FF:00:41 |                 |
+-----+-----+-----+-----+-----+-----+
```

```

+-----+-----+-----+-----+-----+-----+-----+-----+
-----
Total entries : 2 (0 static, 2 dynamic)
-----
--{ [FACTORY] + candidate shared default }--[ ]--
--{ [FACTORY] + candidate shared default }--[ network-instance IP-VRF-10 ]--
# show route-table ipv4-unicast prefix 101.1.1.1/32 detail
-----
IPv4 Unicast route table of network instance IP-VRF-10
-----
Destination   : 101.1.1.1/32
ID            : 0
Route Type    : arp-nd
Metric        : 0
Preference    : 1
Active        : true
Last change   : 2021-04-15T11:58:05.653Z
Resilient hash: false
-----
Next hops: 1 entries
101.1.1.1 (direct) via [irb0.24]
-----
--{ [FACTORY] + candidate shared default }--[ network-instance IP-VRF-10 ]-

```

Example: LEAF-3 imports routes as bgp-evpn host route

```

--{ [FACTORY] + candidate shared default }--[ network-instance IP-VRF-10 ]--
# show route-table ipv4-unicast summary
-----
IPv4 Unicast route table of network instance IP-VRF-10
-----
+-----+-----+-----+-----+-----+-----+-----+-----+
| Prefix          | ID  | Active | Route Type | Metric | Pref | Next-hop          | Next-hop |
|                 |     |        |            |        |      | (Type)           | Interface |
+-----+-----+-----+-----+-----+-----+-----+-----+
| 20.1.1.0/24    | 0   | true   | bgp-evpn   | 0      | 170  | 2.2.2.2 (indirect) | None      |
| 20.1.1.3/32    | 0   | true   | bgp-evpn   | 0      | 170  | 2.2.2.2 (indirect) | None      |
| 22.22.22.22/32 | 0   | true   | bgp-evpn   | 0      | 170  | 2.2.2.2 (indirect) | None      |
| 31.31.31.31/32 | 0   | true   | host       | 0      | 0     | None (extract)     | None      |
| 31.31.31.31/32 | 1   | false  | bgp-evpn   | 0      | 170  | 2.2.2.2 (indirect) | None      |
| 33.33.33.33/32 | 0   | true   | host       | 0      | 0     | None (extract)     | None      |
| 44.44.44.44/32 | 0   | true   | bgp-evpn   | 0      | 170  | 4.4.4.4 (indirect) | None      |
| 101.1.1.0/24   | 0   | true   | bgp-evpn   | 0      | 170  | 2.2.2.2 (indirect) | None      |
|                 |     |        |            |        |      | 4.4.4.4 (indirect) | None      |
| 101.1.1.1/32   | 0   | true   | bgp-evpn   | 0      | 170  | 2.2.2.2 (indirect) | None      |
| 102.1.1.0/24   | 0   | true   | bgp-evpn   | 0      | 170  | 2.2.2.2 (indirect) | None      |
| 103.1.1.0/24   | 0   | true   | local      | 0      | 0     | 103.1.1.3 (direct) | irb0.3    |
| 103.1.1.1/32   | 0   | true   | arp-nd     | 0      | 1     | 103.1.1.1 (direct) | irb0.3    |
| 103.1.1.3/32   | 0   | true   | host       | 0      | 0     | None (extract)     | None      |
| 103.1.1.254/32 | 0   | true   | host       | 0      | 0     | None (extract)     | None      |
| 103.1.1.255/32 | 0   | true   | host       | 0      | 0     | None (broadcast)   | None      |
| 104.1.1.0/24   | 0   | true   | bgp-evpn   | 0      | 170  | 4.4.4.4 (indirect) | None      |
+-----+-----+-----+-----+-----+-----+-----+-----+
-----
16 IPv4 routes total
15 IPv4 prefixes with active routes
1 IPv4 prefixes with active ECMP routes
-----
--{ [FACTORY] + candidate shared default }--[ network-instance IP-VRF-10 ]--

```

6.4.2 Mobility event - efficient host routing

When HOST-12 is attached to LEAF-2, the ARP entry must be maintained even if HOST-12 does not send any traffic. If the entry is removed or ages out, the associated arp-nd host route in IP-VRF-10 is removed and the EVPN-IFL route withdrawn. This can cause hair-pinning for traffic routed from LEAF-3. To maintain the HOST-12 ARP entry (and other dynamic ARP/ND entries), the system supports timer-based ARP/ND refreshes (ARP-Request for the host IP).

Timer-based refreshes are triggered 30 seconds before the ARP age-out timer expires, and irrespective of the arrival of packets requiring resolution for the entry. Note that in SR OS, the **arp-proactive-refresh** command is needed so that entries are always refreshed irrespective of the arrival of packets that hit the entry. In SR Linux, this is the default behavior, so there is no command to enable the timer-based refreshes.

When HOST-12 moves from LEAF-2 to LEAF-4, LEAF-4 must advertise the host route for 101.1.1.1/32 in EVPN-IFL as fast as possible and LEAF-2 withdraws its EVPN-IFL route for it. The process used by LEAF-2 and LEAF-4 to update their ARP/route-tables when HOST-12 moves between them is called "EVPN Layer 3 host mobility". SR Linux provides this support per section 4 of draft-ietf-bess-evpn-inter-subnet-forwarding. EVPN Layer 3 host mobility supports the three cases specified in the draft:

- HOST-12 moves to LEAF-4 and generates a GARP
- HOST-12 moves to LEAF-4 and generates traffic, but not ARP
- HOST-12 moves to LEAF-4 and remains silent

To support fast mobility, SR Linux supports triggered refreshes. Triggered refreshes (ARP-Requests on events and not based on timer expiration) are issued from irb0.24 leaf nodes, for the existing dynamic ARP entry 101.1.1.1>00:00:64:01:01:01. The following events apply:

- an EVPN MAC/IP route for 101.1.1.1-> 00:00:64:01:01:01 is received
- an EVPN route for 00:00:64:01:01:01 (no IP) is received
- 00:00:64:01:01:01 ages out in the mac-table (or the entry in the MAC table is cleared manually)

As shown in [Figure 11: Example of L3 host mobility](#), when HOST-12 moves to LEAF-4, and if it issues a GARP or ethernet traffic, the advertised routes immediately updates the ARP/route tables on both leaf nodes. LEAF-3 then changes its next-hop for HOST-12 from LEAF-2 to LEAF-4.

Example: Silent move - HOST-2 initially attached to LEAF-2

```
--{ [FACTORY] + candidate shared default }--[ ]--
# show arpnd arp-entries interface irb0 subinterface 24 ipv4-address 101.1.1.1
```

Interface	Sub-interface	Neighbor	Origin	Link layer address	Expiry
irb0	24	101.1.1.1	dynamic	00:00:64:01:01:01	3 hours from now

```
-----
Total entries : 1 (0 static, 1 dynamic)
-----
--{ [FACTORY] + candidate shared default }--[ ]--
# show network-instance BD24 bridge-table mac-table mac 00:00:64:01:01:01
```

```
-----
Mac-table of network instance BD24
-----
Mac           : 00:00:64:01:01:01
Destination   : lag1.24
Dest Index    : 20
```

```

Type                : learnt
Programming Status  : Success
Aging               : 2680
Last Update         : 2021-04-15T14:32:45.000Z
Duplicate Detect time : N/A
Hold down time remaining: N/A
-----
--{ [FACTORY] + candidate shared default }--[ ]--

```

Example: Silent move - initial LEAF-4

```

--{ [FACTORY] + candidate shared default }--[ ]--
# show arpnd arp-entries interface irb0 subinterface 24 ipv4-address 101.1.1.1
-----
|Interface| Sub-   | Neighbor | Origin | Link layer | Expiry |
|          | interface |         |        | address    |        |
-----+-----
| irb0    | 24     | 101.1.1.1 | evpn   | 00:00:64:01:01:01 |
-----+-----
-----
Total entries : 1 (0 static, 1 dynamic)
-----
--{ [FACTORY] + candidate shared default }--[ ]--
# show network-instance BD24 bridge-table mac-table mac 00:00:64:01:01:01
-----
Mac-table of network instance BD24
-----
Mac                : 00:00:64:01:01:01
Destination         : vxlan-interface:vxlan1.24 vtep:2.2.2.2 vni:24
Dest Index          : 202418654989
Type                : evpn
Programming Status  : Success
Aging               : N/A
Last Update         : 2021-04-15T14:15:00.000Z
Duplicate Detect time : N/A
Hold down time remaining: N/A
-----
--{ [FACTORY] + candidate shared default }--[ ]--

```

Example: Silent move - watch command output for LEAF-3

```

Every 2.0s: show route-table ipv4-unicast prefix 101.1.1.1/32 detail
(Executions 903, Thu 07:41:40AM)
-----
IPv4 Unicast route table of network instance IP-VRF-10
-----
Destination      : 101.1.1.1/32
ID                : 0
Route Type       : bgp-evpn
Metric           : 0
Preference       : 170
Active           : true
Last change      : 2021-04-15T14:15:00.450Z
Resilient hash: false
-----
Next hops: 1 entries
2.2.2.2 (indirect) resolved by None (None)
-----

```

Example: Silent move - move HOST-12 to LEAF-2

In this example, HOST-12 is moved to LEAF-4 to simulate a silent move. Immediately after flushing MAC 00:00:64:01:01:01 in LEAF-2, the MAC/IP routes are withdrawn and LEAF-2 issues three triggered refreshes.

```
--{ [FACTORY] + candidate shared default }--[ ]--
# 2021-04-15T07:43:16.422816-07:00 dut2 local6|INFO sr_arp_nd_mgr: arpd|1773|1773|20438|I:
  Sending ARP request on interface irb0.24 (10247 - 22). Source Mac : 00:00:5E:00:01:01
  Source IP : 101.1.1.254 Target Mac : 00:00:00:00:00:00 Target IP : 101.1.1.1 Ethernet
  SA 00:00:5E:00:01:01 Ethernet DA FF:FF:FF:FF:FF:FF

2021-04-15T07:43:16.422816-07:00 dut2 local6|INFO sr_arp_nd_mgr: arpd|1773|1773|20438|I:
  Sending ARP request on interface irb0.24 (10247 - 22). Source Mac : 00:00:5E:00:01:01
  Source IP : 101.1.1.254 Target Mac : 00:00:00:00:00:00 Target IP : 101.1.1.1 Ethernet
  SA 00:00:5E:00:01:01 Ethernet DA FF:FF:FF:FF:FF:FF

2021-04-15T07:43:16.422816-07:00 dut2 local6|INFO sr_arp_nd_mgr: arpd|1773|1773|20438|I:
  Sending ARP request on interface irb0.24 (10247 - 22). Source Mac : 00:00:5E:00:01:01
  Source IP : 101.1.1.254 Target Mac : 00:00:00:00:00:00 Target IP : 101.1.1.1 Ethernet
  SA 00:00:5E:00:01:01 Ethernet DA FF:FF:FF:FF:FF:FF

  Flag: 0x90 Type: 15 Len: 77 Multiprotocol Unreachable NLRI:
  Address Family EVPN
  Type: EVPN-MAC Len: 37 RD: 2.2.2.2:24 ESI: ESI-0, tag: 0, mac len: 48 mac:
    00:00:64:01:01:01, IP len: 4, IP: 101.1.1.1, label: 0
  Type: EVPN-MAC Len: 33 RD: 2.2.2.2:24 ESI: ESI-0, tag: 0, mac len: 48 mac:
    00:00:64:01:01:01, IP len: 0, IP: NULL, label: 0
```

Example: Silent move - LEAF-2 updates

When the refreshes arrive at HOST-12 in LEAF-4, the ARP reply is consumed by LEAF-4 (since the MAC destination address matches the anycast-gw MAC address). LEAF-4 then advertises the MAC/IP routes and IP Prefix route for HOST-12.

```
Type: EVPN-IP-PREFIX Len: 34 RD: 4.4.4.4:10, tag: 0, ip_prefix: 101.1.1.1/32
  gw_ip 0.0.0.0 Label: 10
  Flag: 0x40 Type: 1 Len: 1 Origin: 0
  Flag: 0x40 Type: 2 Len: 0 AS Path:
  Flag: 0x80 Type: 4 Len: 4 MED: 0
  Flag: 0x40 Type: 5 Len: 4 Local Preference: 100
  Flag: 0xc0 Type: 16 Len: 24 Extended Community:
    target:64500:10
    mac-nh:00:01:04:ff:00:00
    bgp-tunnel-encap:VXLAN
2021-04-15T07:43:18.763551-07:00 dut2 local6|DEBU sr_bgp_mgr: bgp|4933|5176|2169872|D:
VR default (1) Peer 1: 4.4.4.4 UPDATE: Peer 1: 4.4.4.4 - Received BGP UPDATE:
  Withdrawn Length = 0
  Total Path Attr Length = 97
  Flag: 0x90 Type: 14 Len: 45 Multiprotocol Reachable NLRI:
  Address Family EVPN
  NextHop len 4 NextHop 4.4.4.4
  Type: EVPN-MAC Len: 37 RD: 4.4.4.4:24 ESI: ESI-0, tag: 0, mac len: 48 mac:
    00:00:64:01:01:01, IP len: 4, IP: 101.1.1.1, label: 24
  Type: EVPN-MAC Len: 33 RD: 4.4.4.4:24 ESI: ESI-0, tag: 0, mac len: 48 mac:
    00:00:64:01:01:01, IP len: 0, IP: NULL, label: 24
  Flag: 0x40 Type: 1 Len: 1 Origin: 0
  Flag: 0x40 Type: 2 Len: 0 AS Path:
  Flag: 0x40 Type: 5 Len: 4 Local Preference: 100
  Flag: 0xc0 Type: 16 Len: 16 Extended Community:
    target:64500:24
```

```

    bgp-tunnel-encap:VXLAN
    Type: EVPN-IP-PREFIX Len: 34 RD: 4.4.4.4:10, tag: 0, ip_prefix:
    101.1.1.1/32 gw_ip 0.0.0.0 Label: 10
    Flag: 0x40 Type: 1 Len: 1 Origin: 0
    Flag: 0x40 Type: 2 Len: 0 AS Path:
    Flag: 0x80 Type: 4 Len: 4 MED: 0
    Flag: 0x40 Type: 5 Len: 4 Local Preference: 100
    Flag: 0xc0 Type: 16 Len: 24 Extended Community:
    target:64500:10
    mac-nh:00:01:04:ff:00:00
    bgp-tunnel-encap:VXLAN
2021-04-15T07:43:18.766923-07:00 dut2 local6|INFO sr_arp_nd_mgr:
arpnd|1773|1773|20450|I: The ARP entry for 101.1.1.1 has been updated.

```

After the move, LEAF-2 and LEAF-4 tables are updated, and LEAF-3 points at LEAF-4 as the next-hop for the HOST-12 route.

Example: Silent move - LEAF-2 tables

```

--{ [FACTORY] + candidate shared default }--[ ]--
# show arpnd arp-entries interface irb0 subinterface 24 ipv4-address 101.1.1.1

```

Interface	Sub-interface	Neighbor	Origin	Link layer address	Expiry
irb0	24	101.1.1.1	evpn	00:00:64:01:01:01	

```

-----
Total entries : 1 (0 static, 1 dynamic)
-----
--{ [FACTORY] + candidate shared default }--[ ]--
# show network-instance BD24 bridge-table mac-table mac 00:00:64:01:01:01

```

```

-----
Mac-table of network instance BD24
-----
Mac                : 00:00:64:01:01:01
Destination        : vxlan-interface:vxlan1.24 vtep:4.4.4.4 vni:24
Dest Index         : 202418653897
Type               : evpn
Programming Status : Success
Aging              : N/A
Last Update       : 2021-04-15T14:43:18.000Z
Duplicate Detect time : N/A
Hold down time remaining: N/A
-----
--{ [FACTORY] + candidate shared default }--[ ]--

```

Example: Silent move - LEAF-4 tables

```

--{ [FACTORY] + candidate shared default }--[ ]--
# show arpnd arp-entries interface irb0 subinterface 24 ipv4-address 101.1.1.1

```

Interface	Sub-interface	Neighbor	Origin	Link layer address	Expiry
irb0	24	101.1.1.1	dynamic	00:00:64:01:01:01	3 hrs from now

```

-----
Total entries : 1 (0 static, 1 dynamic)
-----

```

```

-----
--{ [FACTORY] + candidate shared default }--[ ]--
--{ [FACTORY] + candidate shared default }--[ ]--
# show network-instance BD24 bridge-table mac-table mac 00:00:64:01:01:01
-----
Mac-table of network instance BD24
-----
Mac                : 00:00:64:01:01:01
Destination        : lag1.24
Dest Index         : 18
Type               : learnt
Programming Status : Success
Aging              : 2875
Last Update        : 2021-04-15T14:43:18.000Z
Duplicate Detect time : N/A
Hold down time remaining: N/A
-----
--{ [FACTORY] + candidate shared default }--[ ]--

```

Example: Silent move - watch command output for LEAF-3

```

Every 2.0s: show route-table ipv4-unicast prefix 101.1.1.1/32 detail
(Executions 976, Thu 07:44:30AM)
-----
IPv4 Unicast route table of network instance IP-VRF-10
-----
Destination      : 101.1.1.1/32
ID               : 0
Route Type       : bgp-evpn
Metric           : 0
Preference       : 170
Active           : true
Last change      : 2021-04-15T14:43:19.767Z
Resilient hash: false
-----
Next hops: 1 entries
4.4.4.4 (indirect) resolved by None (None)
-----

```

6.5 EVPN-VXLAN Layer 3 feature parity for IPv6 prefixes

All the features discussed in this chapter are supported for IPv6 prefixes and hosts. EVPN IFL works for Prefix IPv6 routes without enabling a separate BGP family. EVPN supports IPv4 and IPv6 routes. In addition, all IRB sub-interfaces must be configured with the IPv6 container using the same commands used earlier in this chapter, but performed under "neighbor-discovery".

6.5.1 Configuring IPv6 Container

Procedure

The following example shows how to configure the IPv6 container.

Example: IPv6 container configuration

```
--{ [FACTORY] + candidate shared default }--[ interface irb0 subinterface 24 ]--
# info
  ipv4 {
    address 101.1.1.2/24 {
    }
    address 101.1.1.254/24 {
      anycast-gw true
      primary
    }
    address 102.1.1.254/24 {
    }
    arp {
      learn-unsolicited true
      debug [
        messages
      ]
      host-route {
        populate dynamic {
        }
      }
      evpn {
        advertise dynamic {
        }
      }
    }
  }
  ipv6 {
    address 2001:db8:24::254/64 {
      anycast-gw true
    }
    neighbor-discovery {
      learn-unsolicited both
      host-route {
        populate dynamic {
        }
      }
      evpn {
        advertise dynamic {
        }
      }
    }
  }
  anycast-gw {
  }
}
```

6.5.2 Additional feature parity considerations

The anycast-gw container is common for IPv4 and IPv6. Therefore, the anycast-gw mac is the same for both families. Only one anycast-gw MAC is programmed in the interface, and IPv4 and IPv6 packets use this anycast-gw-mac as MAC SA when sourcing packets to the BD.

LLA and global addresses are advertised in EVPN. The command **neighbor-discovery learn-unsolicited both** includes global and link local addresses.

The following example shows that when anycast-gw is enabled, an anycast-gw LLA is automatically generated. The anycast-gw ipv6 link local address is based off the anycast-gw-mac when the anycast-gw and the ipv6 containers are present. The logic to compute this new anycast-gw ipv6 link local address is the same as is used for computing the regular ipv6 LLA except the anycast-gw-mac is used instead of the

interface mac. This new ipv6 LLA appears in the list of ipv6 addresses associated with the subinterface, but with the attribute **anycast-gw true**.

Multicast NS messages use the anycast-gw LLA and anycast-gw MAC. Unicast NS use the global IPv6 and hw-address.

Example: LLA generation

```
--{ [FACTORY] + candidate shared default }--[ interface irb0 subinterface 24 ipv6 ]--
# info from state
  address 2001:db8:24::254/64 {
    anycast-gw true
    origin static
    primary
    status preferred
  }
  address fe80::200:5eff:fe00:101/64 {
    anycast-gw true
    origin link-layer
    status preferred
  }
  address fe80::201:2ff:feff:41/64 {
    origin link-layer
    status preferred
  }
  neighbor-discovery {
    duplicate-address-detection true
    reachable-time 30
    stale-time 14400
    learn-unsolicited both
    neighbor fe80::201:4ff:feff:41 {
      link-layer-address 00:01:04:FF:00:41
      origin evpn
    }
  }
  host-route {
    populate dynamic {
    }
  }
  evpn {
    advertise dynamic {
      admin-tag 0
    }
  }
}
router-advertisement {
  router-role {
    current-hop-limit 64
    managed-configuration-flag false
    other-configuration-flag false
    max-advertisement-interval 600
    min-advertisement-interval 200
    reachable-time 0
    retransmit-time 0
    router-lifetime 1800
  }
}
}
```

7 Security hardening using CPM filters

Protecting the control and management plane of each routing switch in the data center fabric (access leaf, border leaf, spine) from unauthorized or out-of-profile sources of traffic is important. Without control plane protection policies, routers are vulnerable to attacks on the data center infrastructure and performance degradation can occur because of misconfiguration.

The SR Linux supports a special Access Control List (ACL) type called a cpm-filter for control plane protection. There are separate Control Processing Module (CPM) filters for IPv4 traffic and for IPv6 traffic. The entries of each cpm-filter are installed on each line card and in the Control CPM software. There are different types of cpm-filter actions that can be applied and all actions are not relevant at all locations. [ACL configuration for control plane protection](#) defines each action and how to configure it.

7.1 Applicability

The information and configuration in this chapter are based on SR Linux Release 19.11.

7.2 ACL configuration for control plane protection

ACLs support primary and secondary actions. There are two mutually exclusive primary actions:

- **accept** - Allows the packet through to the next processing function.
- **drop** - Discards the packet without Internet Control Message Protocol (ICMP) generation.

There are three optional secondary actions that are supported in any combination. Secondary actions extend the primary action with additional packet handling operations.

- **log** - Extracts information about each matching packet and sends it to the log application.



Note:

The **accept+log** action is not supported on 7220 IXR-D1, D2, and D3 systems. Only the action **drop+log true** is supported.

- **distributed-policer** - Sends the packet to a policer instance implemented in the forwarding ASIC of the ingress line card. This policer sends the packet to the CPM only if the policer token bucket does not go into the exceed/violate state. The rate of a distributed-policer is defined in units of kb/s and the bucket depth is defined in units of bytes.
- **system-cpu-policer** - Sends the packet to a policer instance implemented by CPM software when the packet reaches the CPM from any line card as source. This policer admits the packet to its owner application only if the policer token bucket does not go into the exceed/violate state. The rate of a system-cpu-policer is defined in units of packets-per-second and the bucket depth is defined in units of packets.

7.2.1 CPM filter rules

CPM filter rules that apply a system-cpu-policer or distributed-policer action do not directly specify the policer parameters. Instead, the rules refer to a generically defined policer under the ACL configuration tree. This allows different CPM filter entries, even across multiple ACLs, to use the same policer if needed. Optionally, each policer can be configured as entry-specific. This means that a different policer instance is used by each referring filter entry, even if they are part of the same ACL.

CPM filter ACL actions are applied to the following traffic flows:

- IPv4 and IPv6 traffic flows originating by external systems, arriving on any line card port, accepted by the interface ACLs applied to the ingress subinterface (if any), system ACLs applied globally, and determined to be locally terminating by lookup of the IP destination address
- IPv4 and IPv6 traffic flows originating by external systems, arriving on the Out-of-Band (OOB) management port and accepted by the interface ACLs applied to ingress traffic on the OOB port subinterface, and system ACLs applied globally. If the CPM-filter policy has distributed-policer actions, these are ignored for inbound traffic on the OOB management port.

The startup configuration of a new SR Linux router includes a default IPv4 cpm-filter policy and a default IPv6 cpm-filter policy. These default policies block packets associated with any protocol that is not supported by the SR Linux operating system. However, they do not limit the sending sources or enforce any rate limits aside from ICMPv4/ICMPv6 traffic, which is subject to an aggregate rate limit of 1000 pps. The default policies should be modified to add these additional restrictions, and to allow protocols associated with NetOps Development Kit (NDK) applications, if applicable.

7.2.2 Restricting source subnets for incoming traffic using CPM filter

Procedure

The following examples define how to restrict the source subnets for incoming SSH traffic associated with remotely originated TCP connections to a specified IP address.

Example: (IPv4 address of 192.0.2.0/24)

```
--{ candidate shared default }--[ acl cpm-filter ipv4-filter ]--
# entry 100 match
--{ candidate shared default }--[ acl cpm-filter ipv4-filter entry 100 match ]--
# source-address 192.0.2.0/24
--{ * candidate shared default }--[ acl cpm-filter ipv4-filter entry 100 match ]--
# protocol tcp destination-port value ssh
--{ * candidate shared default }--[ acl cpm-filter ipv4-filter entry 100 ]--
A:srlinux# action drop
-{ * candidate shared default }--[ acl cpm-filter ipv4-filter entry 100 ]--
# info
  description "Restrict the source subnets 192.0.2.0/24 for incoming SSH Traffic"
  action {
    drop {
    }
  }
  match {
    protocol tcp
    source-address 192.0.2.0/24
    destination-port {
      operator eq
      value ssh
    }
  }
}
```

Example: (IPv6 address of 2001:db8:3200/48)

```
--{ candidate shared default }--[ acl cpm-filter ipv6-filter entry 140 ]--
A:srlinux# match next-header tcp destination-port value ssh
--{ * candidate shared default }--[ acl cpm-filter ipv6-filter entry 140 ]--
A:srlinux# match source-address 2001:db8:32::/48
--{ * candidate shared default }--[ acl cpm-filter ipv6-filter entry 140 ]--
A:srlinux# action drop
-{ candidate shared default }--[ acl cpm-filter ipv6-filter entry 140 ]--
A:srlinux# info
description "Restrict the source subnets 2001:db8:32::/
48 for incoming SSH Traffic"
  action {
    drop {
    }
  }
  match {
    next-header tcp
    source-address 2001:db8:32::/48
    destination-port {
      operator eq
      value ssh
    }
  }
}
```

Customer document and product support

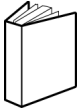

Customer documentation

[Customer documentation welcome page](#)



Technical support

[Product support portal](#)



Documentation feedback

[Customer documentation feedback](#)